

Copyright, 1922, by American Carpenter and Builder Company.



Formerly AMERICAN CARPENTER AND BUILDER

Member of the Audit Bureau of Circulations
Circulation Audited and Verified April, 1922

American Builder

Entered as second-class matter July 1, 1905, at the post office at Chicago, Ill., under the Act of Congress of March 3, 1879.

Published on the first day of each month by

AMERICAN CARPENTER AND BUILDER COMPANY

Publication Offices:

Radford Building, 1827 Prairie Ave., Chicago

TELEPHONE: CALUMET 4770

EASTERN OFFICE: 261 BROADWAY, NEW YORK CITY

ADVERTISING RATES

Furnished on application. Advertising forms close on the 15th of the month preceding date of publication.

SUBSCRIPTION RATES

One year, \$2.00; six months, \$1.00; single copies, 35 cents. Special rates for two or more subscriptions when received together, to be sent to different addresses—Two subscriptions, \$1.75 each; three subscriptions, \$1.50 each; five subscriptions, \$1.25 each; ten or more subscriptions, \$1.00 each. Extra postage to Canada, 50 cents; to foreign countries, \$1.00.

PROTECTION FOR OUR READERS

The publishers of the AMERICAN BUILDER reserve the right to decline any advertising they believe is detrimental to the interest of its readers; to edit advertising copy and to change or eliminate any statements that reflect injuriously or cast discredit upon other building products, machinery, equipment, supplies or tools.

Be sure in writing to advertisers to say: "I saw your advertisement in the AMERICAN BUILDER."

EDITORIAL DEPARTMENT

WILLIAM A. RADFORD, *Editor-in-Chief*

BERNARD L. JOHNSON, B. S., *Editor*

WM. B. REEDY Associate
J. D. EDDY Editors
A. W. WOODS

BUSINESS DEPARTMENT

WM. A. RADFORD, *President and Treasurer.*

E. L. HATFIELD, *Vice-President and General Manager.*

ROLAND D. RADFORD, *Secretary.*

DELBERT W. SMITH Advertising
C. R. W. EDGUMBE Staff
L. H. REICH
E. B. WOLFROM

VOL. 33

May, 1922

No. 2

Table of Contents

	Page		Page		Page
Around the Family Table	85	How One Progressive Lumber Company Keeps the Idea Continuously Before the Public	117	Brick Adds Charm to Colonial Design	138
Plan Service During Busy Season	85	Law for the Builder	116	White Trim Against Red Background Provides Harmonious Color Scheme in Nine-Room House	138
Advertising the Building Business	85	Pleasing Cottage Design with Native Stone Trim	115	What's New?	140
Covering the Building Field	85	Small but Distinctive Bungalow	114	Machine Cut Lumber Speeds Up House Framing for Contractor	140
Hard to Build—Easy to Destroy	85	Design of Safe Construction	120	Rolling Screen Permanent Part of House	140
Short Talks by the Editor	89	Reinforced Concrete Pressure Tank	120	Paint for Galvanized Iron	140
Secretary Hoover's Code Committee Offers Its Small House Code	89	Coziness Predominates in This Bungalow Design	118	Hardwood Veneer Door Has Unique Construction Features	142
City Buildings	90	Two-Apartment Building—An Attractive Investment Offering	122	Electric Floor Sander Completes Job	142
Some Attractive Brick Apartment and Bungalow Designs	90	Waterproofing Basement Walls	122	Handy Saw Table Can Be Easily Carried	142
American Building Skill Is Restoring Louvain	93	How Special Waterproofed Plaster Coat Is Applied to Keep Dampness Out of Basements	122	Service Elevator Is Important Equipment in Business Buildings	142
American Architects, Building Contractors and Money Are Rebuilding Famous Library Destroyed in Great War	93	House Construction Details in Concrete	124	New Steel Fabric for Stucco	144
Artistic Doorways	96	Details of Construction and Attractive Designs of Fireplaces	124	Truck Dump Bodies Speed Up Building Job	146
Simplicity of Treatment in This Popular Colonial Design	98	Laying the Variegated Asphalt Roof	127	Many Hours Are Saved by Automatic Loading Facilities on Motor Trucks	146
Essentially Practical and Substantial House Design	99	New Roofs from Old Rags	127	Hammering and Adjusting Circular Saws	148
Our Front Cover Home	100	Metal Construction	128	Keeping Edge Strained on Straight Line Is Important	148
Comfortable, Comely Cottage Design	102	Laying Batten Copper Roofing and Flashings	128	Steel Square	150
Unusual Exterior Treatment Makes Home Design Distinctive	103	Correspondence Department	131	How to Use the Steel Square	150
The Bungalowette	104	Believes "Bungalowette" Will Help Building Shortage	131	How to Build for Steel Sash	156
English Half-Timber Home of Charm and Appeal	106	Sends Guide for Setting Ground	131	Method of Building Walls to Hold This Type of Sash	156
Attractive Square House with Ornamental Hip Roof	107	Time Card Suggestions	132	Statement of Ownership, Management, Circulation, Etc.	172
Co-Op Apartment Building—How It Is Done	108	What Would You Advise?	132	News of the Field	170
Cozy Bungalow with Enclosed Sun Porch	110	Rafter Span Troubles Him	133	New Wadsworth-Howland Factory	170
Informal Comfort Is Feature of This Home	111	Is This Truss O. K.?	133	Pittsburgh Builders Offer Scholarship	170
The Arch—Past and Present	112	Cantilever Beam Problem	133	Chain Belt Appoints Pittsburgh Manager	170
Some of the Charming Indoor Possibilities of This Architectural Feature	112	Here Is a Practical Suggestion	133	Annual Meeting of Austin Corporation	170
Advise the Building Business	117	American Builder Helps Him Land Contract	134	Fire Destroys Shrager & Johnson Factory	170
		Flat Roof Does Not Drain Quickly	134	Catalogs, Bulletins and Books Received	174
		How Is Quarter-Sawed Oak Obtained?	134		
		University Student Practical Builder	134		
		Parn Construction a la Radford	136		
		Further Information on Fuel Oil Burner	136		
		Walls Are Not Damp Proof	136		



Andersen Frames Save Time and Lumber

FROM a stock of 11 sizes of Andersen Standard Window Frames, the dealer can make immediate delivery of 121 different sizes of frames, simply by interchanging heights and widths. This convenience of immediate delivery represents a direct saving of time and money on the job.

Made-to-order frames must be ordered weeks in advance. Because they're made up in small quantities, they cost more money. Too often, delivery dates are uncertain. Andersen Standard Frames eliminate delays and unnecessary expense. Specialization gives many opportunities for saving of lumber and elimination of waste. These economies are passed on to users of Andersen Frames.

Andersen Standard White Pine Frames are accurately made. All exposed parts

are made of genuine White Pine which endures for centuries without warping, rotting, shrinking or swelling. Windows fit snugly yet run easily in Andersen Frames because of the accurate White Pine construction.

No time is wasted in assembling Andersen Frames on the job. An Andersen Frame is packed in two compact bundles containing seven units. Using only a hammer, these seven units can be nailed up complete, with pockets and pulleys in place, in ten minutes, or less.

The Complete Story

On request, we will send an interesting book on the qualities and economies of Andersen Frames. Write today, and we will send a copy without charge.

Andersen Lumber Company
Department A-5 South Stillwater, Minn.



Andersen FRAMES

Short Talks by the Editor

Sec'y Hoover's Code Committee Offers Its Small House Code

THE preliminary report of the Building Code Committee of the U. S. Department of Commerce has just been issued, dated March 30, 1922. It presents a schedule of "Minimum Requirements for Small House Construction" on which the committee asks for criticisms and suggestions. Later on this report is to be revised and then printed for general distribution; it will be recommended by Secretary Hoover to all town, city and state governments as the basis for building code legislation.

The introduction to the report points out the committee's belief that regulations for dwelling constructions are a pressing necessity. The great scarcity of dwellings throughout the country, especially the small one- and two-family types, reported by various organizations investigating that subject during the last two years, made it apparent that any assistance the committee could render in reducing the cost of such construction would be immediately helpful. Secretary Hoover was particularly interested in this phase of the work and at his request the committee gave it precedence.

The financial importance of such construction is indicated by statistics compiled by the Chamber of Commerce of the United States which show that the cost of such structures built during the year 1920 was about 75 per cent of the total cost of dwelling accommodation provided in cities, and about 28 per cent of the total cost of all classes of building construction. One- and two-family dwellings made up 42 per cent of all building operations reported, and both this percentage and the proportion of total cost given undoubtedly would have been greater if figures could have been obtained from more small cities and towns.

According to dependable statistics the present shortage of homes in the United States is 1,200,000. It is apparent, therefore, that if building regulations could be so modified and standardized as to effect even a small saving on each building without endangering its efficiency or permanency, a large total economy would result.

This report deals only with construction of dwelling intended for the occupancy of not more than two families between exterior or party walls. No recommendations are made as to proportion of lots that buildings may cover; the distance between buildings or between buildings and lot lines; or the effect upon construction imposed by such considerations. Lack of reference to these features is not due to their unimportance, the committee states, but merely because they were considered beyond the scope of the present report.

An Advisory Committee on Zoning has been organ-

ized in the Division of Housing to assist the Department on city planning questions. All matters such as those mentioned above and those concerning necessities for light and air, also the general suitability of buildings as living quarters will be considered jointly with that committee and recommendations made later.

The requirements recommended in this report constitute, in some particulars, relaxations from those considered advisable for construction of large buildings. The committee believes, however, that for the simple types of buildings specified, and because of the need of eliminating all possible waste, the minimum standards advised are compatible with a due measure of utility and durability in the structures affected. The objects which the Committee had in view in recommending these regulations were:

1. To help eliminate waste in home building.
2. To secure safe and yet economical construction.
3. To reconcile inharmonious and frequently too restrictive provisions in existing codes.

The recommendations are predicated on the assumption that good materials and workmanship will be used and all necessary care taken in assembling the various parts of the structures. The committee feels that thoro building inspection is often lacking and that many unnecessarily rigid code requirements have been adopted to offset possible laxity in enforcement. In modifying such provisions to reduce cost, therefore, local authorities should insist upon supervision of construction by an adequate, competent personnel.

These recommendations are based on a considerable volume of building code analyses, statements of opinion, and test data. The committee desires that they be regarded as tentative in nature and that they receive the fullest and freest discussion by all interested in such matters. The committee does not wish to force its personal views upon the public, but is anxious to have the final form of its recommendations represent the best possible foundation of fact and the concensus of qualified public opinion as to suitable minimum requirements. It believes that laws thus formed will come as near being standard as reasonably to be expected and that they would doubtless receive generous support.

The committee therefore wishes to develop all possible information bearing on these subjects and to receive the benefit of opinions based upon different viewpoints. Constructive criticism is especially solicited. All such material received will be given careful consideration in preparing a revised and final draft of the recommendations. It is hoped that they may then be in acceptable form to be adopted freely as building ordinances by the several hundred municipalities now entirely without such laws and to be used in revision of antiquated existing ordinances.

As They Build In Cities

SIX AND TWO-APARTMENT BUILDING DESIGNS AND TYPICAL URBAN TYPE BRICK BUNGALOW

UNCLE SAM has been wearing a pair of shoes many sizes too small for the past three or four years as far as housing supply is concerned. In these shoes the cities have been the little "toes," getting the full benefit of the "pinch," at the same time developing a man-sized corn that will take some time and attention to get rid of.

But the happy day has come when the nation can put on a larger pair and the tension on the cities can be relieved. As this year grows older, this relief will become more positive because many apartment buildings of various sizes from two up to forty are now under way or contemplated for the spring and summer. Moreover, there will be many brick bungalows built by those who prefer the individual home and who must conform to city fire ordinances which prescribe this material.

Apartment building construction is not confined only to the larger cities. The demand is being voiced in smaller towns as well. What preparations have the builders made for this demand? That remains to be seen. To give him a lift, some typical designs of city homes and buildings are presented here with floor plans.

First is shown a six-apartment building, a very popular and profitable size from the standpoint of the owner. It is an attractive investment for those who have the means, offering as it does income from six

flats which now bring a high price, or five in addition to the flat occupied by the owner himself. This building is constructed of brick, with an attractive face brick facade embellished by artistically chosen terra cotta sills, lintels and other trim.

The individual apartments are five rooms, each with sun parlor. There are three apartments on each side

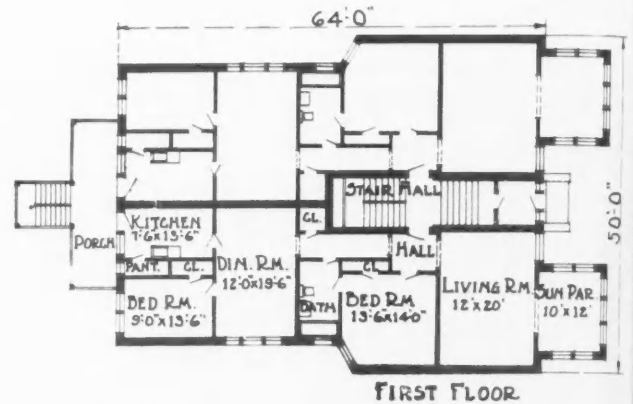

Typical Floor Plan of Six-Apartment Building.

of the central hall and stairway which affords access to them. In each apartment the rooms are living room, dining room, two bedrooms and kitchen. The rooms are not large, but ample for the needs of the average family. The living room and dining room are not adjoining, as in many cases, but are separated by a hall, off which are a bedroom, 13 feet 6 inches by 14 feet, and bathroom. The dining room is at the rear of the house, next to the kitchen, and is 12 by 19 feet 6 inches in size, with a triple window, affording excellent light. A small rear bedroom is located off this dining room. The kitchen is of the small modern type with pantry. The sun parlor in front is really an additional room, altho not classified as such. It is enclosed and heated and gives the apartment the benefit of much additional light thru its many windows in front and sides.

Passing to the smaller apartment, the two apartment size, perhaps the most popular type of structure in the cities because of its cost and investment possibilities, we find a substantial building, 24 by 49 feet, with solid brick walls, face brick facade with stone trim and plain but dignified entrance. Two large sun parlors are a feature that can-



Six-Apartment Building of Brick Construction with Terra Cotta Trim. Each Apartment Has Five Rooms and Sun Parlor. The Building Is 50 Feet Wide and 64 Feet Long.



Typical Two-Apartment Building, Viewed with Favor by the Majority of Home-Seeking Public of Moderate Means. Note the Two Large Sun Parlors, Sturdy Brick Walls and High Basement. Each Apartment Has Five Rooms. Size, 24 by 49 Feet.

not be overlooked by the architects and builder because they add considerable sales value to the building. In this case, the sun parlors are really an extension of the living room, permitting a room 13 by 18 feet, which is indeed an advantage and one that will appeal to the prospective purchaser. Sun parlors have increased the cheerfulness of the average city apartment threefold because of the additional light they afford.

In this two-apartment building the lower floor has five rooms, part of the first floor space being occupied by the reception hall and stairway to the second

floor. The space occupied by this hall on the first floor is available on the second floor, where an alcove off the living room is indicated. This alcove can be used as den, or, if necessary, as an extra sleeping room. With this exception, the floor plans of both apartments are identical. There are living room, dining room, 11 feet 6 inches by 13 feet, with four windows providing natural sunshine, two bedrooms, one off the dining room, the other off a short rear hallway, and a small, compact kitchen. This type of building is suited to the 30-ft. city lot—24 feet plus the required 3 feet open on each side to the lot line.

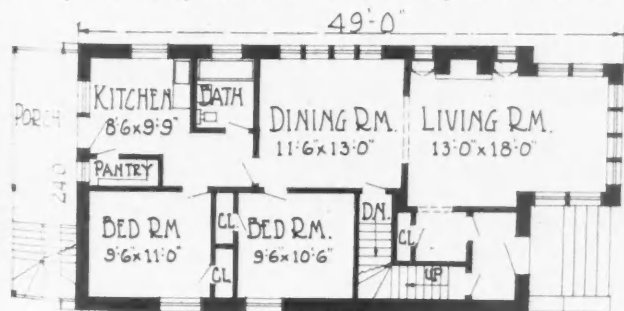

FIRST FLOOR

First Floor Plan of Two-Apartment Building Showing Room Arrangement.

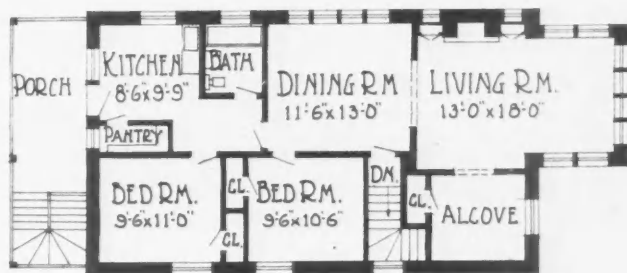

SECOND FLOOR

Second Floor Plan of Building Above. An Alcove Replaces the Hall on the First Floor.



Interior View of Typical Apartment Sun Parlor Showing Advantage of Exterior Window Space. The Sun Parlor Adds Another Room to the Floor Plan.

The basement is high, well lighted by windows on the sides and rear, and is equipped with modern laundry tubs, electrical outlets for machines, hot and cold water. In a building of this type, one heating plant will be sufficient, altho in many designs individual heating plants are specified. This feature eliminates any friction that may arise between tenants and landlord over heat.

While the apartment has outdistanced all types of

building in the cities because of the added income it affords in limited space, the individual home by no means is out of style. Many bungalows are being built every day, most of them conforming to certain general lines, typified in the design shown below.

This brick bungalow design is one that you will see in any city. It represents ultimate economy in home construction, and it is within the reach of the man of slim pocket-book. Particularly noticeable is the absence of frills, yet the exterior is quite pleasing. The construction is permanent, calling for solid brick walls, concrete foundation and strong roof. As in the case of all modern designs, the sun parlor is an important feature.

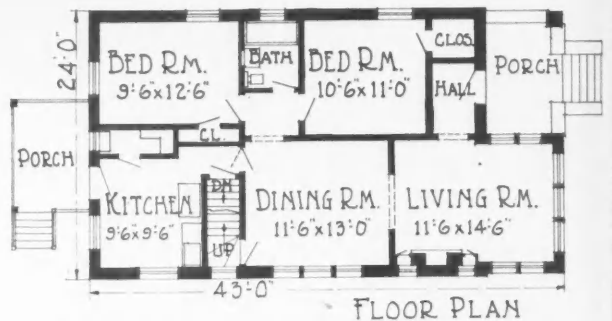

Typical Floor Plan of Brick Bungalow Shown Below.



Attractive and Practical Brick Bungalow Design Which Is Being Built in Large Numbers in Most Cities. It Offers a Permanent Home of Five Rooms and All Modern Comforts. This House Is 24 Feet Wide and 43 Feet Long.

Archit
 AMER
 C
 famo
 mans
 It
 by th
 anothe
 of the
 resto
 testin
 in thi
 tion
 the w
 condi
 who
 In
 libran

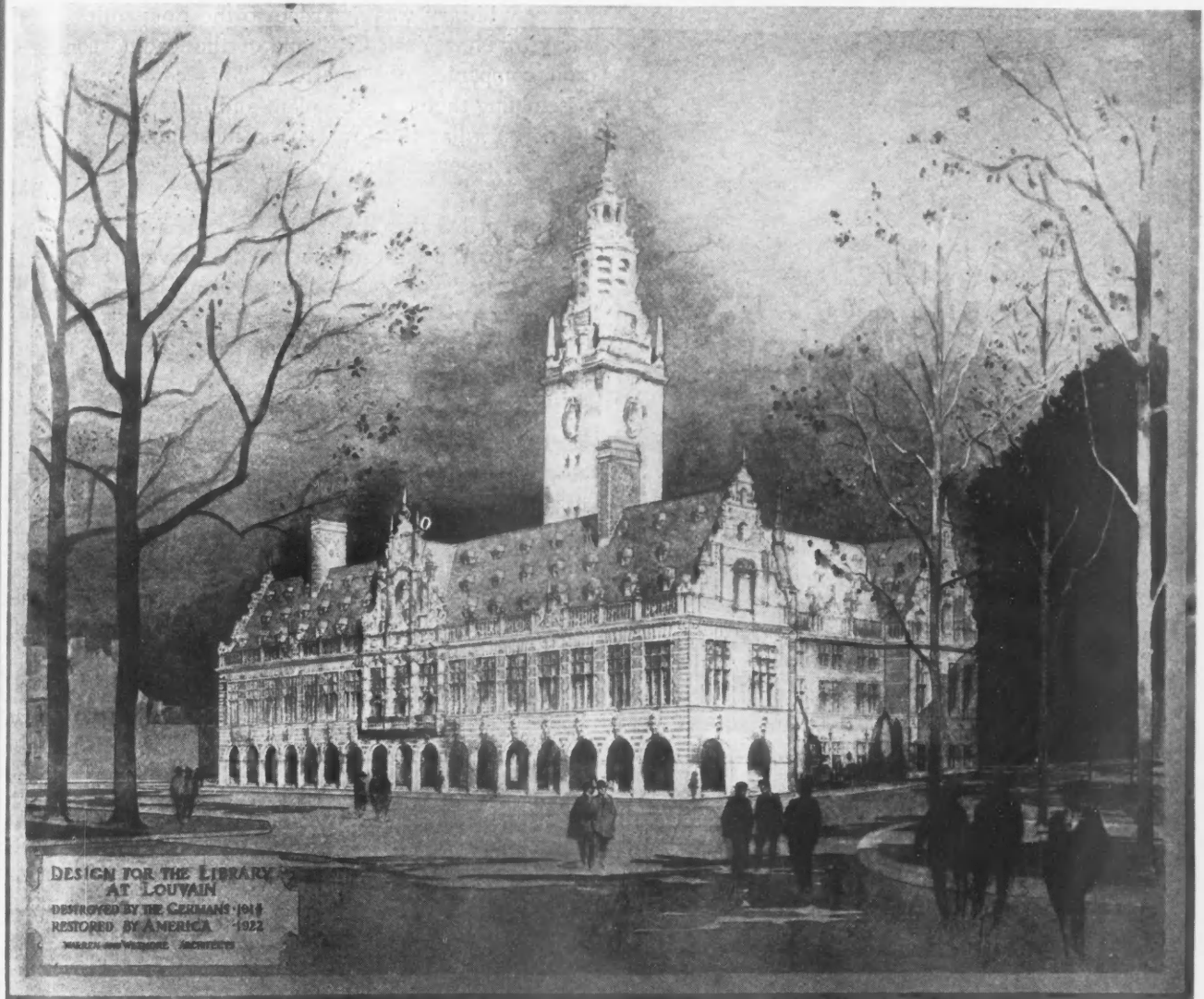

Architectural Rendering of Proposed Louvain University to Be Built by Americans with American Money Donated by American University Students.

American Building Skill Is Restoring Louvain

AMERICAN ARCHITECTS, BUILDING CONTRACTORS AND MONEY ARE REBUILDING FAMOUS LIBRARY DESTROYED IN GREAT WAR

By Hewitt Crosby

ONE of the most interesting chapters in the romance of American building and architectural history is now being enacted in the famous city of Louvain, Belgium, destroyed by Germans in the invasion of August, 1914.

It is not only another of a long list of achievements by the building fraternity of this country, but is another striking instance of the whole-hearted liberality of the American people at large. For this project, the restoration of the century famous library is a gift and testimonial on the part of the students of universities in this country as a token of admiration and appreciation of the part little Belgium took at the outset of the war to stem the Germans under the most adverse conditions, and as a memorial to American students who lost their lives in the great war.

In 1919, five years after the destruction of the library, an American committee was formed, with

Nicholas Murray Butler, president of Columbia University, as chairman, and proposed to Cardinal Mercier, president of the Louvain University, and to the Belgium government, that the students of America would be proud to help in the restoration of the University of Louvain. The committee offered specifically to assume responsibility for a new library of Louvain to take the place of the old. Funds for the preliminary work were quickly raised and Whitney Warren of the American architectural firm of Warren & Wetmore, New York City, was selected as the architect.

Early in 1921 the plans were completed, and on July 28, 1921, the cornerstone of the proposed new edifice was laid by President Butler in the presence of the King and Queen of the Belgians, Cardinal Mercier, President Poincaré and Marshal Petain of France and other notable world figures.

On March 30 the contract for the construction of



View of Old Louvain as It Appeared After the German Invasion in 1914. This Historic Structure Will Soon Be Replaced by a Modern Building. It Was at One Time Captured by Napoleon.

the new library was awarded to the Foundation Company of New York City, one of the leading construction companies of America. This company is now assembling the necessary plant and materials for active work on what thus far is the most important single piece of reconstruction in the war-devastated areas of Europe.

On April 3 the National Committee of the United States for the Restoration of the University of Louvain formally opened the active campaign among the faculties and students of American schools, colleges and universities for the raising of a fund of \$800,000 in the form of one-dollar contributions.

Messrs. Warren & Wetmore are the architects and Mr. Warren is himself devoting nearly all of his time towards raising the money necessary for the rebuilding of Louvain University.

Louvain Library has had a romantic history and had one of the largest collections in the world.

Thru the efforts of the Duke of Brabant the University of Louvain was founded in Louvain, Belgium, in 1425, with its class rooms in the old Clothmaker's Hall, the industrial center of the city.

It was not until more than two centuries later that the university began to accumulate a library. In 1636 the first official librarian of the Louvain Library was

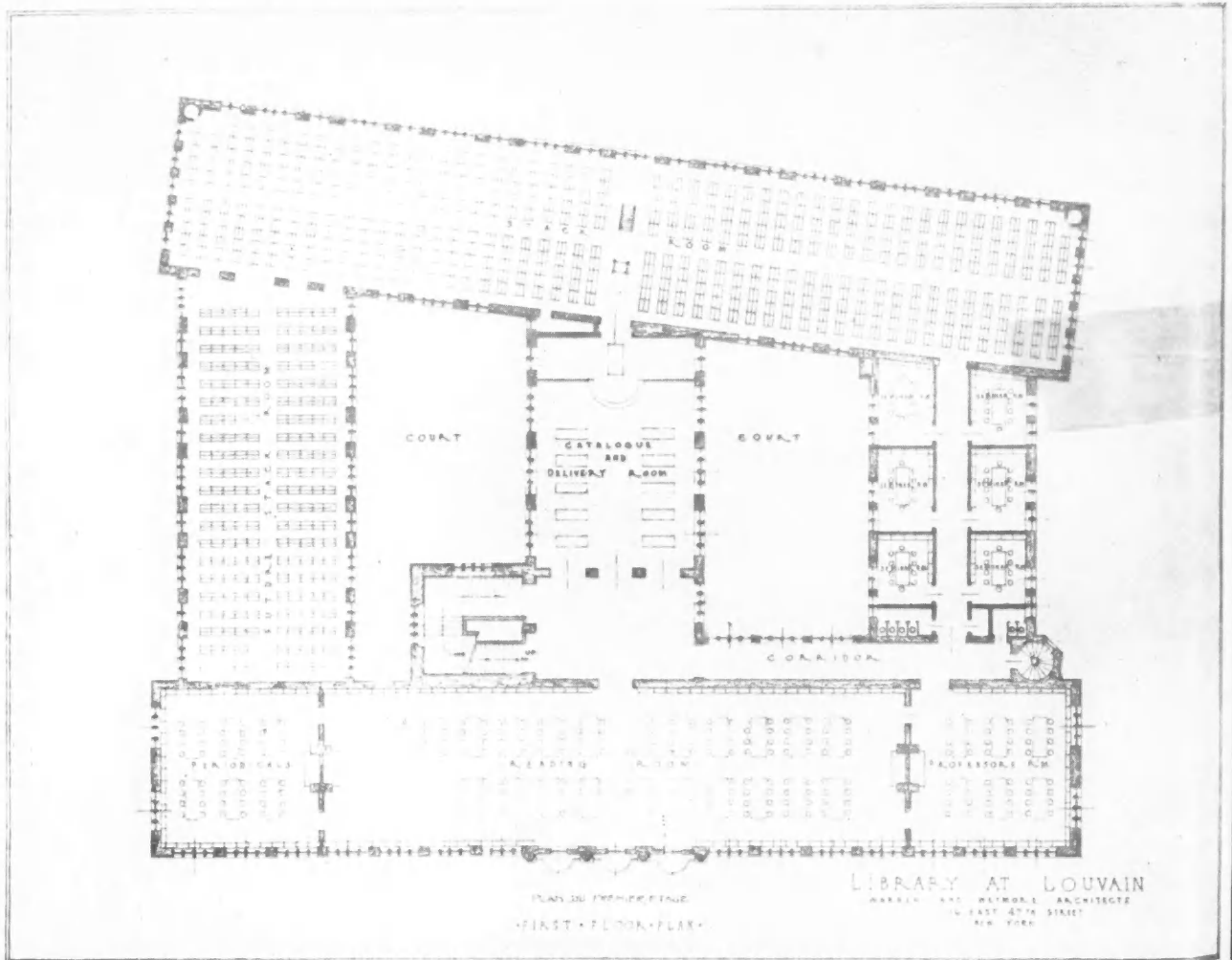

First Floor Plan of New Louvain University, Showing Main Reading Rooms, Stacks, Seminar Rooms, Corridors and Delivery Room. The Old Library Had One of the Largest Collections in the World.

appointed, and on August 22 of that year a special section was set apart for the collection.

On December 12, 1805, the conquering Napoleon took the Library from the University of Louvain and deeded it to the city, but thirty years later the city turned it back to its original custodians.

It continued to grow and prosper until the fateful night of August 25, 1914, when the historic structure and its priceless contents, the slow accumulation of nearly five centuries, were in a few brief hours reduced to ashes by the invading Germans.

Destruction of Louvain Library

On August 4, 1914, the German armies began their invasion of Belgium and on August 19 entered Louvain. For a solid week, the gray, steel-helmeted steam poured thru the city on its course towards France.

At midnight on August 25, fire broke out in the Louvain Library. A cordon of German soldiers speeded the flames with incendiary bombs and liquid fire and before daylight the famous Library and Clothmaker's Hall were a mass of smouldering ruins.

Over 300,000 rare volumes and thousands of irreplaceable manuscripts were destroyed. On the day following the fire, 40,000 inhabitants of Louvain were driven from the city.

The floor plan of the new library is shown here with elevation of the tower and main building.



Viewpoint of Banker on Building Future

RESIDENCE building this year in millions of square feet is 183 as against only 132 last year, an increase there of almost 50 per cent. Business buildings have shrunk. School building is active and getting more active. The proportion is rising and there is an enormous shortage of school buildings. Industrial construction, which in 1920 amounted to 124 million, is down to roughly one-quarter of that amount in 1921. That sluggishness still continues, and will for some time to come, in most parts of the country.

"Amusements, which largely means movie theaters, are 33 per cent ahead of last year. Hospitals are well along toward double. Churches also well along toward double. Public buildings are the same as in 1920.

"So we have these buildings that have to do with business and industry, sluggish; but residences, schools, theaters, recreation halls, hospitals, churches, public buildings, catching up with the deficiency. Of course business recovers, as it has already started to do, gradually, and I think it will be a long and slow and irregular recovery.

"So I should say that the outlook for the construction industry is one of a most extraordinary sort and an outlook that has an exceptional promise for good business on a falling market. When I say on a falling market, I mean a market of falling prices for general business.

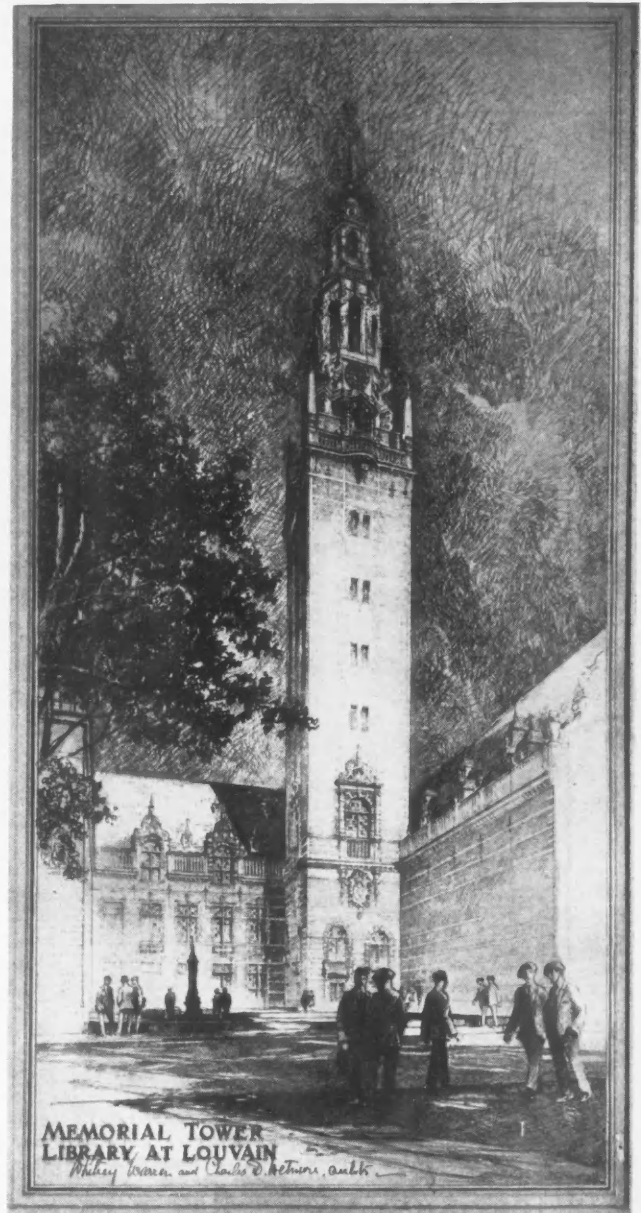

Memorial Tower of New Building. The Building Was Designed by Warren & Wetmore, Architects, and Is Being Built by the Foundation Co., New York City.

"The construction industry thus enters a period of great accumulated shortage at a time when interest rates have fallen far, far below what they were and when the difficulties and problems of financing are rapidly disappearing—so rapidly that my own expectation is that within six months most of the acrimonious discussions that you and we have indulged in will be at an end. Thus I think the problems of financing are largely ended because money is easy and seeking investment, prices have come down to a relative stability, a shortage exists.

"Those are the three factors which are necessary and present for increased activity in the building industry. We are entering this era at a time when your industry, like every other industry, is going to find that its problem is one of more efficient management and of delivering to the buyer a large value for the dollar that he has given.—LEONARD P. AYRES, vice-president Cleveland Trust Co., Cleveland, Ohio.

ARTISTIC DOORWAYS

English Cottage Approach—Outside Cream Stucco. This Inviting Entrance Has a Border Arch in Rich Brown with Walk and Vestibule Paved with Red Brown Tile. An Appealing Door of Distinction.

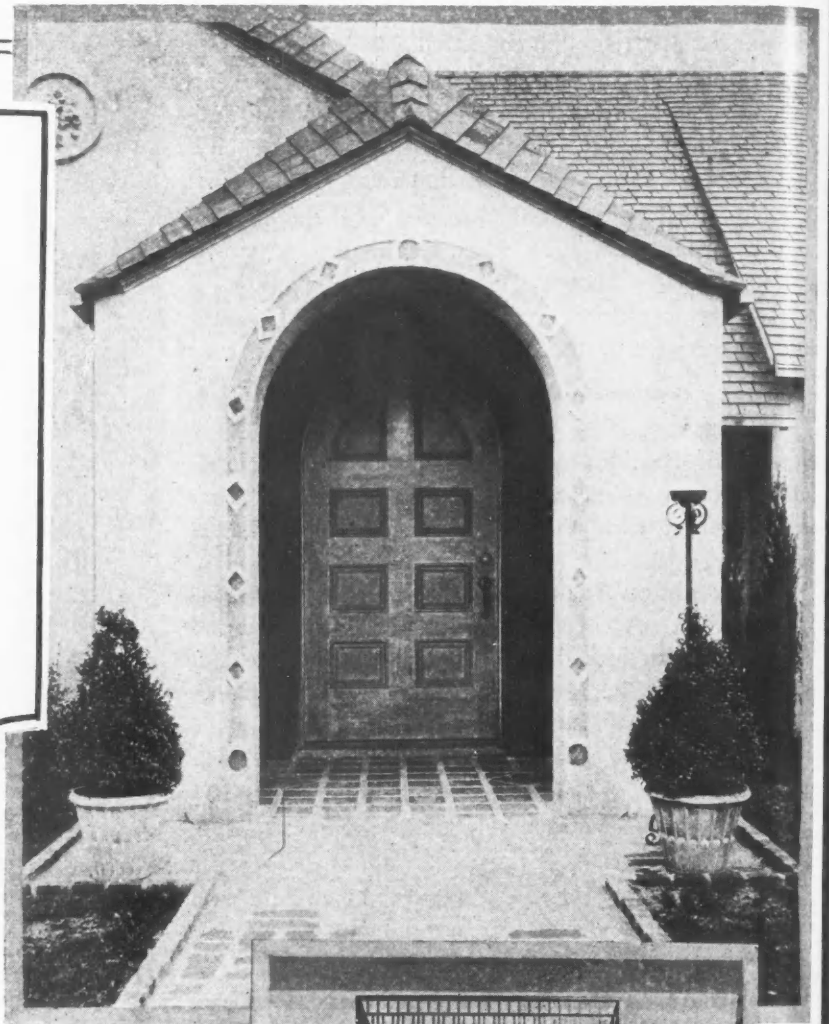

Hark You Back to the Early Days of California with Its Flat Roofed Missions and Simple Dignified Architecture. This is a Typically Spanish Doorway Found Frequently Thru the Orange-Kissed Country of the Southwest. It Derives Much Beauty from Its Simple Tone and Lines, and Completes the Charm of the Picturesque Mission Home.

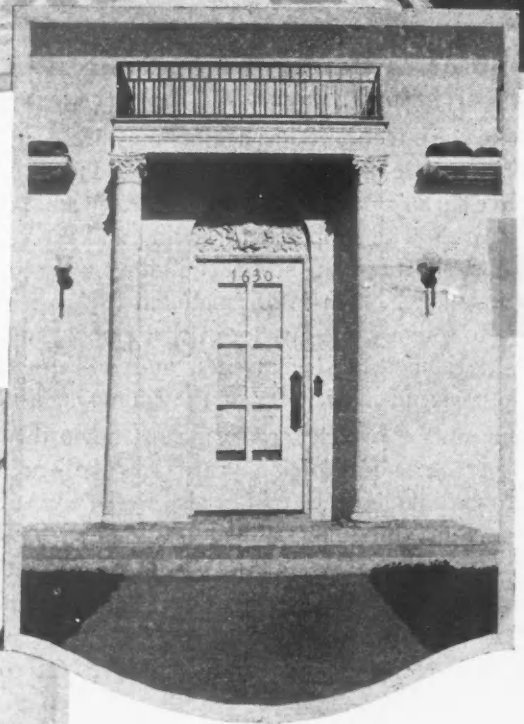

Ornateness Enters Into This Doorway Treatment. Cast Artificial Stone with Elaborate Design Has Been Used for Framing This Entrance. It Forms a Fitting Background for the Heavy Single Door Which Gives the Visitor a Distinct Impression of Solidity and Character.

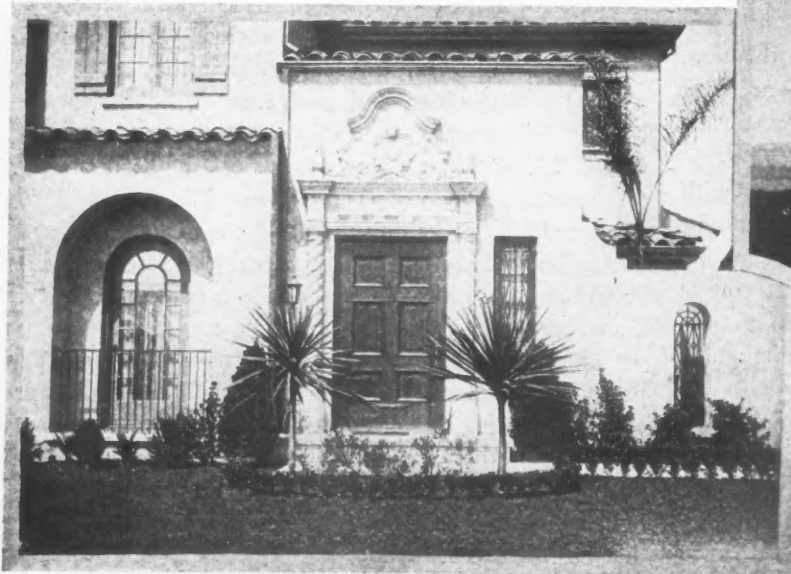

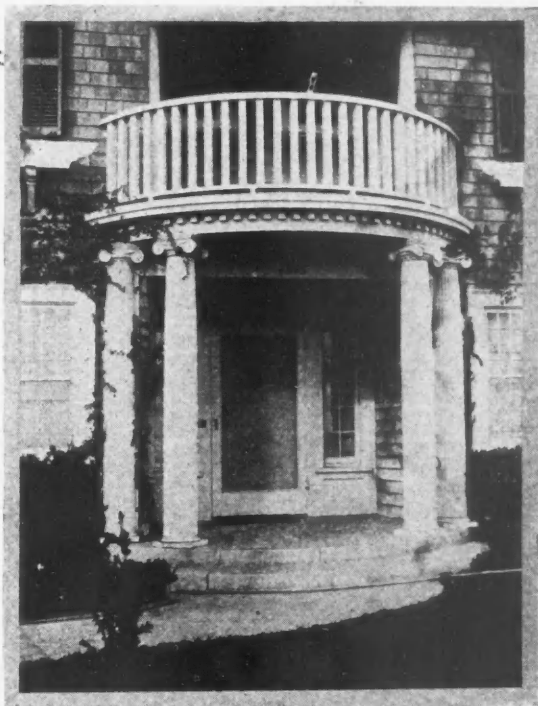

Go Where You May, You Cannot Find an Entrance That Will Offer More Hospitality than the Colonial. The Doorway Above Is of the Modified Colonial Type with Balcony Above Supported by Fluted Metal Columns. The Porch Platform Is Semi-circular in Shape and Made of Concrete. This Entrance Is Not Pretentious, but Artistic Because of Its Simplicity.

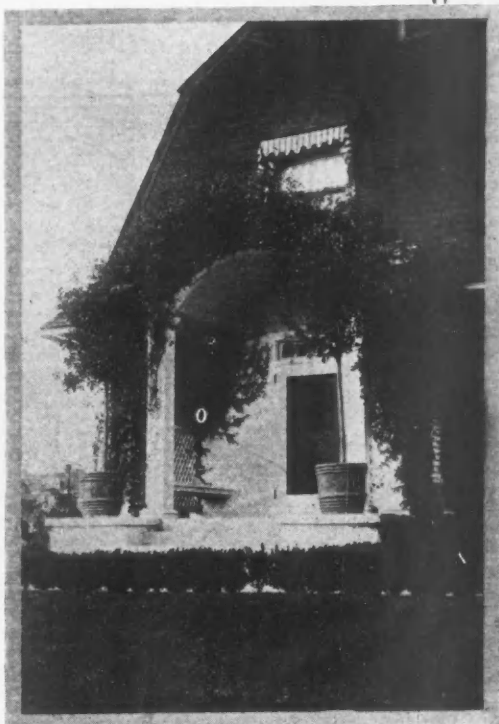

Above Is Shown a Glimpse of a Dutch Colonial Doorway Enhanced by Vines and Lattice. It Is Quite Simple in Design, Consisting of an Arched Hood, Supported by Two Square Wooden Columns. There Are Two Side Seats, Which Always Add to the Appeal of the Doorway, and a Projecting Terrace of Concrete Where Flower Urns Can Be Placed. This Entrance Blends Well Into the Landscape.

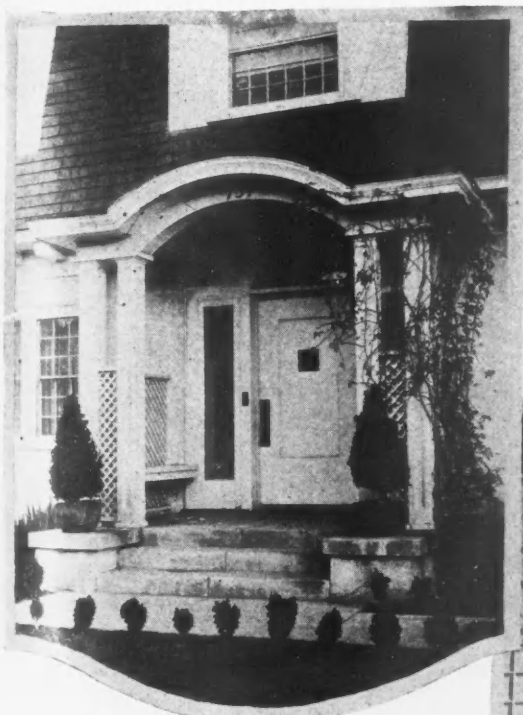

To the Left Is Another Type of Dutch Colonial Entrance That Holds Forth a Decided Appeal. Variation in Seat and Arch Design Are Offered in This Detail. Again Modesty Rather than Boldness in Treatment Is Noticeable.

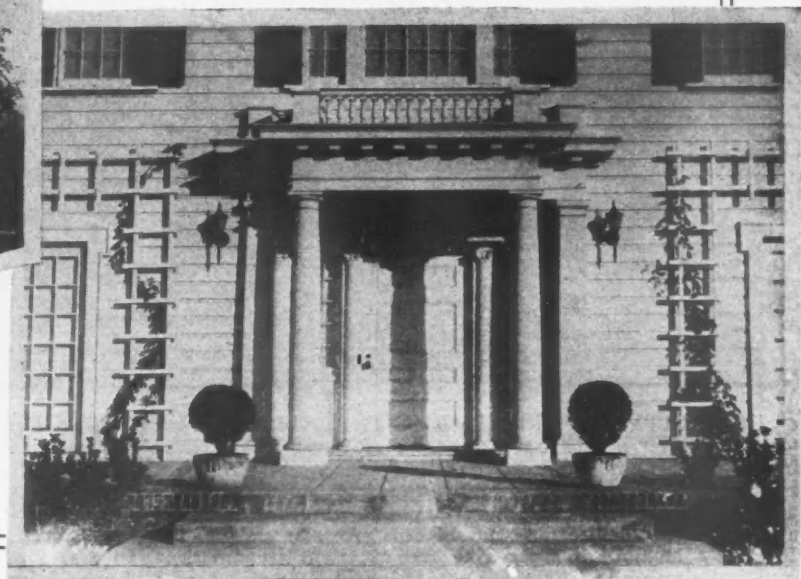

To Your Right You Will Find Another Variation in Colonial Doorway Treatment. This Time a Rectangular Roof with Balcony and Rail. The Porch Is Brick. Rose Ladders on Each Side Offer Additional Decoration That Is Not Displeasing.

BLUE RIBBON HOMES

PRACTICAL & ARTISTIC

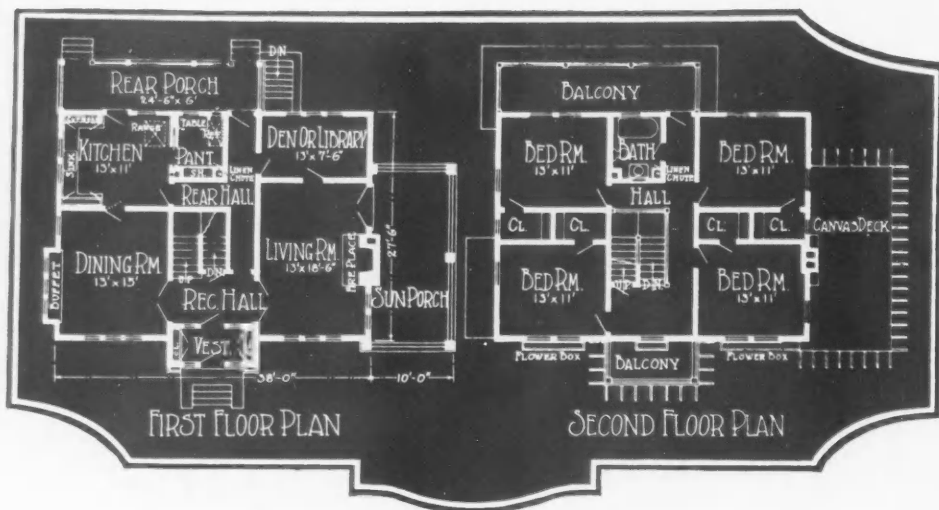

SIMPLICITY OF TREATMENT IN THIS POPULAR COLONIAL DESIGN. People get tired of most any-thing after a time but it seems they never lose interest in this simple but charming home design. Its charm lies in its sheer simplicity and common sense lines, free from costly and unsightly frills and freaks. This house is built of frame on a brick foundation. It has the usual attractive entrance with small roof and balcony above; variation from the usual orthodox Colonial windows and shutters, however, is offered in the casement windows with arched lintels on the first floor front. At one end a large open porch is a welcome addition. There are eight rooms, four on each floor of good size and excellent arrangement. In case the library is not desired, the partition can be left out and the entire space devoted to living room. Size of house 3 by 27 feet 6 inches.

E S
this
block
front
at th
on t
to th

BLUE RIBBON HOMES

PRACTICAL & ARTISTIC

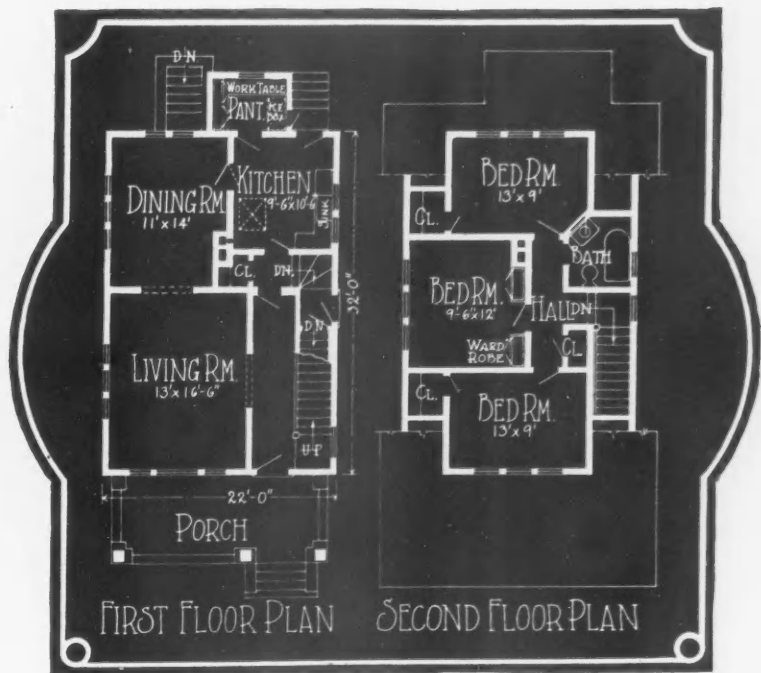

ESSENTIALLY PRACTICAL AND SUBSTANTIAL HOUSE DESIGN. For those seeking a real value for their expenditure, a solid, well-built home, plain in treatment rather than ornate, yet attractive and comfortable, this design will end their search. It is a story and a half of frame, part drop siding, part shingles, with concrete block foundation. Across the front extends a wide open front porch covered by an extension of the main roof. The front door opens into a hall which gives ready access to the living room on one side and kitchen and dining room at the far end. A side entrance also opens into this hall. The plan calls for six rooms, the three bedrooms being on the second floor. The house is not too large for the average family and the rooms are arranged with a thought to the comfort of the housewife. Especially is this the case in the location of the kitchen. Size, 22 by 32 feet.

OUR FRONT COVER HOME

“WAY back when I was a boy they didn't have these high-powered automobiles that make you jump across the street to save your life, nor did they have this new-fangled radio that catches music out of the air,” mused the old veteran regretfully as he saw the May front cover home.

“But,” he added quickly, and a smile lighted up his wrinkled face. “we had homes in those days, every single family of us. And we had Colonial homes, too—that is one thing we had that still holds its popularity. Why, do you know, grandfather lived in a house like that when he was a boy. And that's nigh onto a century ago. Believe me, you, there is something about a home that will hold the hearts of the people for such a long time—and not only that but grow in popularity with each generation. It must satisfy the requirements of a real home.”

And it does without question. Only the other day we received a letter from a builder in Washington State saying:

“You can't publish too many Colonial designs to suit me. Out here they are enjoying more popularity than most designs.”

Yet the Colonial was distinctly an Eastern type.

The Front Cover home this month typifies the best there is in Colonial design and in doing this also presents the best there is in real home construction. Simplicity, quiet dignity, spacious comfort are the qualities that make this home so appealing, that makes it tug at the hearts of all homelovers.

There it stands, set low on the ground, its white

walls with green shutters, and roof rising up in picturesque contrast to the green background, a hospitable artistically-treated entrance beckoning to those who would enter. There is no entrance so appealing,



Interior Decorative Suggestion for Dining Room of Colonial House Such as is Shown on Front Cover. Simplicity Within as Well as in Exterior Design Makes the Colonial House the Acme of Hospitality and Comfort.

so inviting as that of a Colonial house. It is the focal center of the whole facade. In this home it is straightforward, relief from plainness being afforded by a small hood and mouldings applied to the frame.

There are two features in this home, however, that the old man who was expressing his opinions at the opening did not have in his day; one is the garage built at one end of the house, the other the living porch on the opposite end, screened in to provide a sleeping porch or lounging place in the warm weather. These are outgrowths of more modern developments, particularly the built-in garage. This arrangement

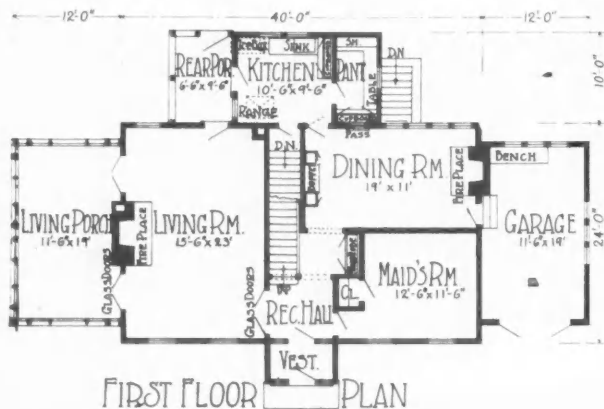

First Floor Plan of Front Cover Home. Note the Spacious Provision for the Living Room.

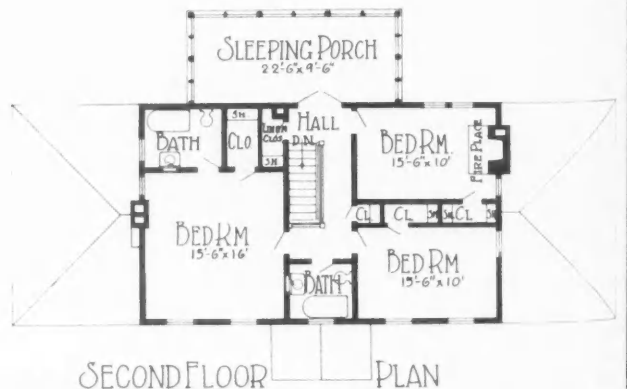

Second Floor Plan of Front Cover Home. Three Bedrooms, Two Baths and a Large Sleeping Porch Make This Floor Perfect.

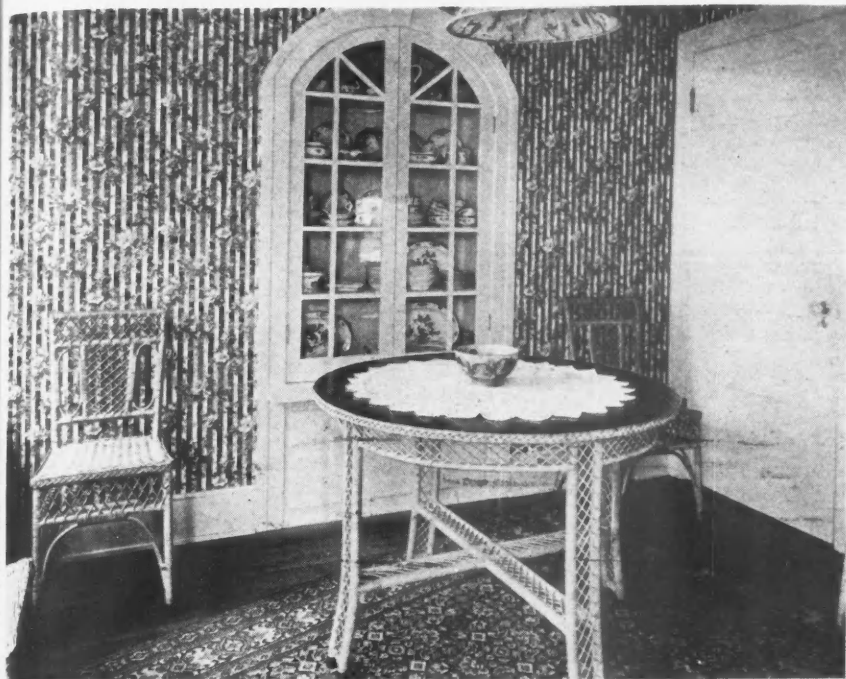

Again the Charming Simplicity of the Colonial Motif Is Demonstrated. An Excellent Idea for a Built-in China Closet in the Dining Room or Small Breakfast Room if One Is Provided. Note the Wicker Furniture in Keeping with the Cheerful Sunny Character of This Room.

only tends to increase the comfort embodied in this home. A doorway from the dining room, which is at that end of the first floor, opens into the garage. Thus, in the morning or whenever one of the family wants to go out driving, it is but a matter of a step or two into the car. Then, of course, in cold weather, this feature has the advantage of keeping the car from freezing, this garage being heated by the house plant.

Living and sleeping porches, too, are now important parts of every home. Both have been included in this plan, the sleeping porch being located over the kitchen in the plan of the house. It is a large room, an excellent place for sleeping.

In the matter of room arrangement to the right of the house in connection with the living porch is the living room, a spacious room 15 feet 6 inches by 23 feet. It extends from front to back of house, giving three full sides for windows. In the center of the end wall between living room and porch is a large typically Colonial fireplace where a great roaring fire on cool nights will fill the room with warmth and cheer and make it an ideal recreation center for the family. Details of fireplace construction have appeared in recent numbers of the AMERICAN BUILDER. There is an article on this subject in this issue.

In making up the room arrange-

ment the reception hall should, of course, be mentioned first, opening, as it does, the way to the other rooms. On the opposite side of this hall from the living room are two rooms, one the dining room, 19 by 11 feet, the other a maid's room 12 feet 6 inches by 11 feet 6 inches, the latter in front of the house. In a wing at the rear of the house the kitchen is located with back porch and pantry. The sleeping porch is located just above this room.

There is plenty of opportunity for variety in arrangement of rooms on the second floor but in this particular plan three bedrooms and two baths are shown. The master bedroom has a private bathroom in connection while the other bath is located at the end of the hall. Two bedrooms are located on the other side of the house. The large bedroom and one of the smaller ones have doors opening out on to

the rear sleeping porch.

Western wood was used in the construction of this Eastern type home which has prototypes in many Middle Western cities. In other words, a sectional architecture has gradually become national in its scope and popularity. Economically, the Colonial house ranks among the first because its simplicity of design prevents any expensive "frills and furbelows"; physically, it is strong and durable, as so many mature examples so vividly prove beyond doubt, and superficially, it is a thing of beauty, which, as Keats so sagely remarked, "is a joy forever."

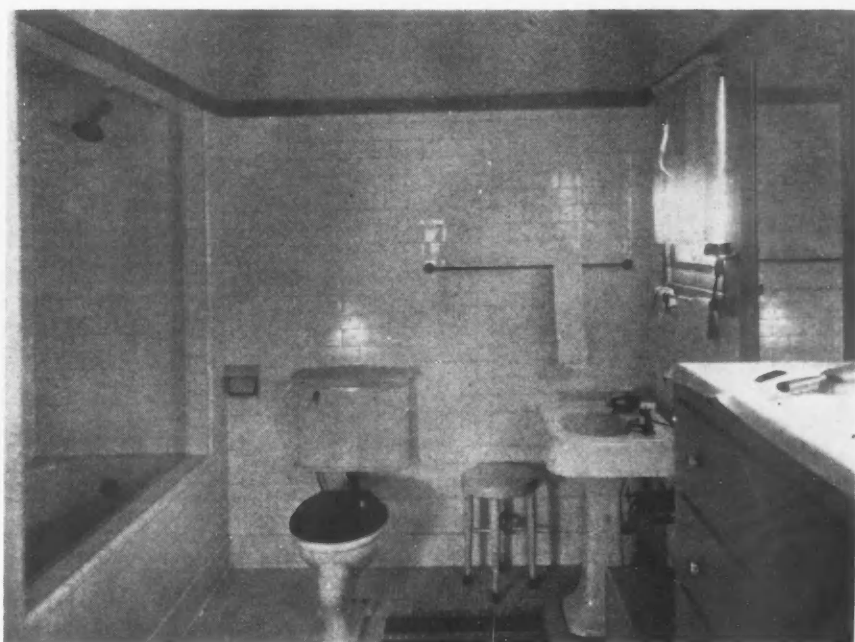

Small, Compact Bathroom with Built-in Tubs, Sanitary and Bright Tile Floors and Walls Are Demanded by Prospective Home Builders. The Front Cover Home Should Have a Bathroom of This Size.

PRACTICAL & ARTISTIC **BLUE RIBBON HOMES**

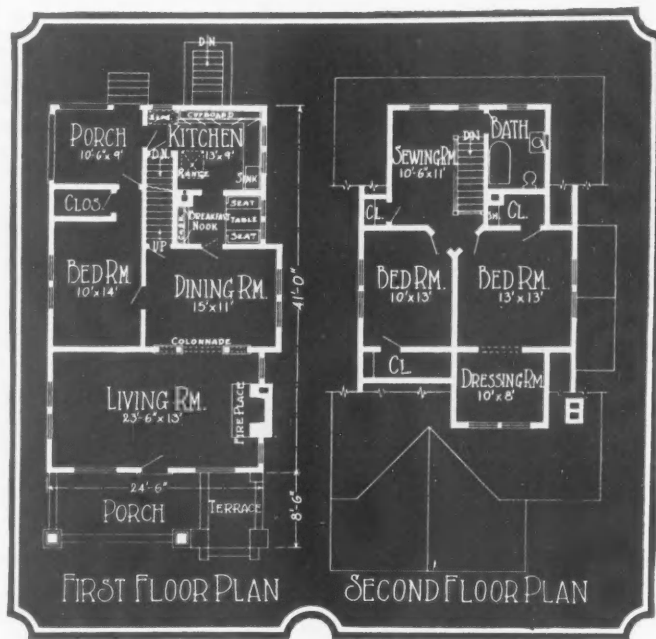

COMFORTABLE, COMELY COTTAGE DESIGN. A house of this type always appeals strongly to the home-seeker of moderate means. It has all the qualities of the complete home, attractive exterior, substantial construction, and well proportioned room with conveniences. The foundation is solid concrete, while brick has been used for porch rails and foundation. A wide chimney marks the location of the open fireplace in the living room which is 23 feet 6 inches by 13 feet, an unusually large and comfortable room for a house of this size. Dining room, kitchen, and one bedroom are the other rooms on the lower floor. Two bedrooms, dressing room, and sewing room are located upstairs, either of two latter rooms being available for children's nursery or bedroom. The house is 24 feet 6 inches by 41 feet.

U
bric
has
as t
effe
feet,
fron

BLUE RIBBON HOMES

PRACTICAL & ARTISTIC

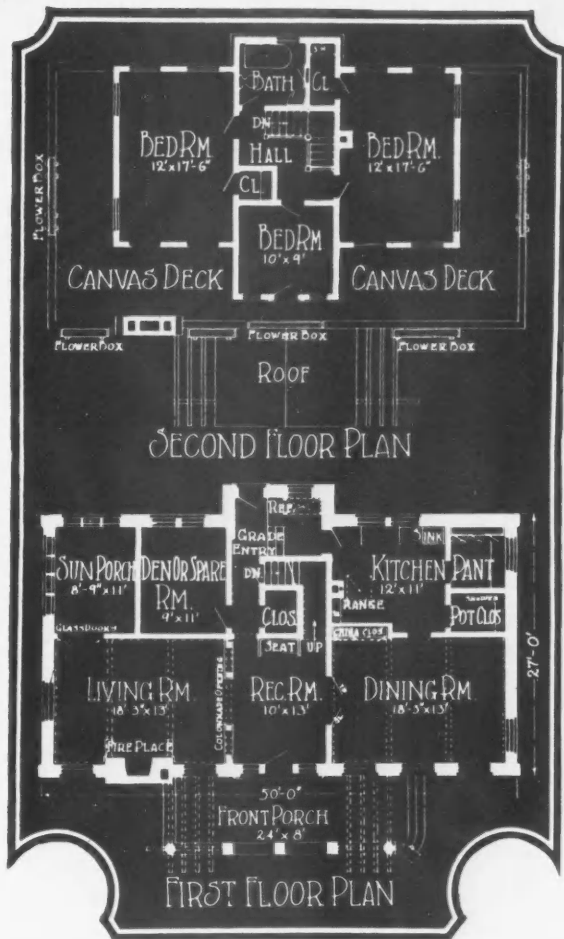

UNUSUAL EXTERIOR TREATMENT MAKES HOME DESIGN DISTINCTIVE. Rather odd pattern, this, is exceptionally bright and colorful, like so many other homes from the sunny Southwest. The exterior is brick and stucco with the second floor drawn back so as to provide a balcony around the front and two sides. This has been covered with special canvas flooring. The house belies the impression of bigness which it tends to offer, as the outside measurements are only 50 by 27 feet, inclosing seven regular rooms and a sun porch. The cupola effect of the second floor contains three bedrooms, two of which are 12 by 17 feet 6 inches, and the third, 10 by 9 feet. On the first floor are the living room, dining room, kitchen, den or library and good-sized reception hall. The front porch is partially covered by roof. A large open fireplace has been built in the living room.

The Bungalowette



Two Pages of Suggestions for Those Who *Must Have A Home* However Small and Modest

Here is a very timely chance to do some good. No doubt some of our readers know of little homes like this built in an emergency and successfully lived in. Please write and tell us about them, and send a photo. It will help others.—The Editor.

KNUT HAMSUN is a Norwegian. Previous to 1921 very few in America ever heard of him. Today he is quite famous. He won the Nobel prize for the best book during the year. And the book—

Well, it is a simple story of simple folk who started in a simple way and grew and developed. When they

first settled on wild, uninhabitable land, they had little in the way of shelter, little in the way of conveniences and comforts of the home. But they worked with their hands, tilled the soil, sold their crop and added to their little home. Each year they went thru this process, each year bettering home conditions. It is a tale of perseverance, one that many families in this



Three-room Bungalowette, 24 by 16 Feet, With Rear Wing for Kitchen and Bathroom. A Cozy Little Home That Can Be Built for Small Amount—A Home That Will Accommodate Family of Five in Modest Comfort.

country can follow with benefit.

Especially is this true in the matter of home ownership. If a family is unable to build a real home with all of the conveniences right away, why should they not be content to do as this simple Norwegian couple did, build something not quite so good until they are in a position to build better? Certainly they will never get in this position if they continue to pay rent.

That is the idea behind the "bungalowette," the bungalow's little sister. In this plan, the modest family is offered relief from the rents prevailing, and in a few years the ambitious homeowner can build the house he has dreamed of. This bungalowette can be set at the rear of the lot. When prosperity comes, it can be converted into a garage. As one engineer writes, "The idea is excellent. This type of house will cost about \$900." He lives in California—this price will, of course, vary, but not much.

Why? Because the house is small, simple in design and can be built of cheap material. It is set upon posts or solid foundation depending upon section in which it is built. There is no excavation necessary.

The frame siding is quite plain, brightened up by window and door frames painted white. The roof is low and covered with prepared roofing. In front there is a simple but dignified entrance with small porch and single door. This door admits one into a good-sized living room, 13 by 15 feet, equipped with a wall bed, which is pulled out of its concealing closet at night. This living room serves the purpose of three rooms: living room, dining room and bedroom.

To one side is a small bedroom, also fitted with disappearing bed, and in the rear in a small wing are the kitchen and bathroom.



Distinguishing Characteristics of Mahogany

ONLY true mahogany from tropical America, "African mahogany," and "Philippine mahogany" are commonly sold as mahogany in this country, but at various times over 60 different species of timber have been sold under that name. Altho all of these species resemble each other in varying degrees, tropical

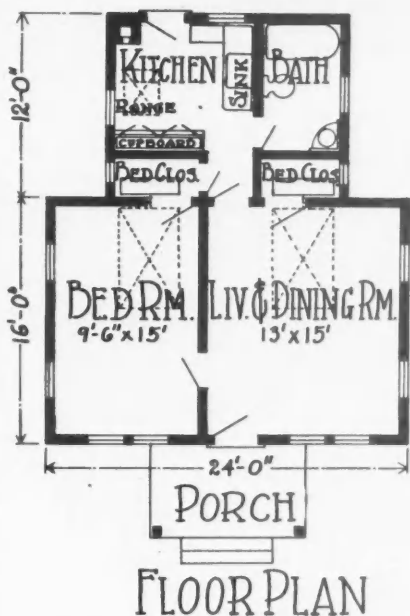

Floor Plan of "Bungalowette" Shown on Opposite Page.

American mahogany and "African mahogany" possess one important characteristic in common. This is the occurrence of dark amber-colored gum in many of the pores. The gum does not fill the pores but is recognized as dark specks or streaks in the pores as seen on end or side grain. This gum is barely visible to the naked eye, but it is easily seen thru a hand lens with a magnification of 10-15 diameters. In preparing the end grain of the wood for examination, a very sharp knife should be used to make a smooth cut.

Some other woods have similar dark masses of gum in the pores, but none of these are commonly substituted for mahogany. Among them are crabwood and sapeli, species imported from South America in small quantities only, and the Cedrelas (Spanish cedar, etc.), which are rarely sold as mahoganies, and are easily recognized by their odor.

True mahogany has fine, continuous, concentric lines on the cross section usually from 1/8 to 1/2 inch apart, which distinguish it from "African mahogany" in which these lines never occur.

"Philippine mahogany," altho not marked by the black masses of gum, is distinguished from true mahogany and other so-called mahoganies by the presence of fine, white, tangential lines 1/8 inch to several inches apart, readily visible to the naked eye, and showing under a lens as rows of small openings filled with a white substance.

A more complete key and description of mahogany and so-called mahogany, which describes common species in detail, may be obtained from the Forest Product's Laboratory, Madison, Wis.



The Shortage of Homes in Berlin is Almost as Great as it is in this Country, Except That Here We Have Greater Resources for Construction. The High Cost of Building Materials Has Compelled Builders to Use Empty Cartridge Boxes, Filled with Mud and Put Together, Completing What is Known as an "Ersatz," One of Which is Pictured Here.

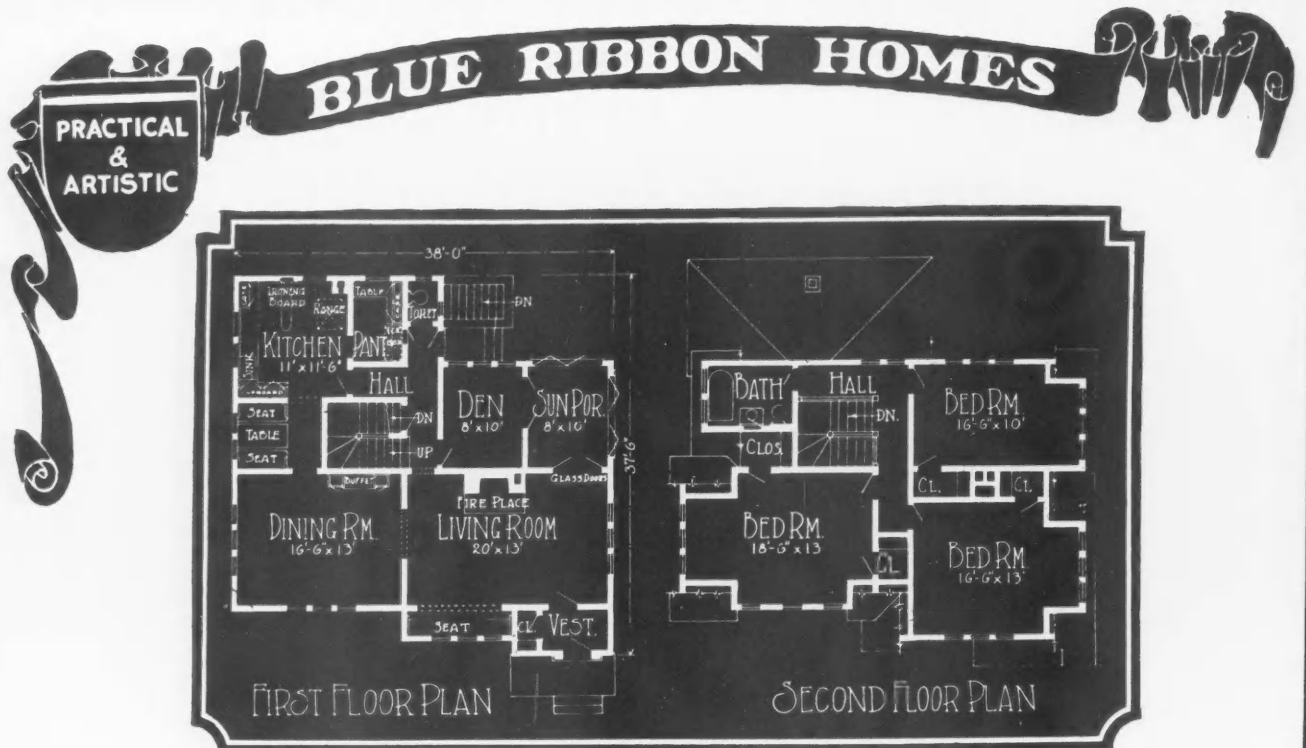

ENGLISH HALF TIMBER HOME OF CHARM AND APPEAL. Easily one of the most appealing types of houses that can be built. The timber panels on stucco background with the well cut-up roof, quaint entrance and dark-stained window frames and sash combine to make a very attractive exterior. The building as drawn is built of frame with stucco over metal lath. Set low on the ground, it offers the impression of maturity and blends itself well into the picturesque setting. Interior room arrangement calls for a typical living room with fireplace, an adjoining library or den, sun parlor, bright dining room, kitchen with breakfast room supplement and three bedrooms, the latter on the second floor. Each of these sleeping rooms has splendid light and ventilation afforded by plenty of window space. The house is 38 feet wide and 37 feet 6 inches long.

A
hip
cus
det
livi
the
bee
gar

BLUE RIBBON HOMES

PRACTICAL & ARTISTIC

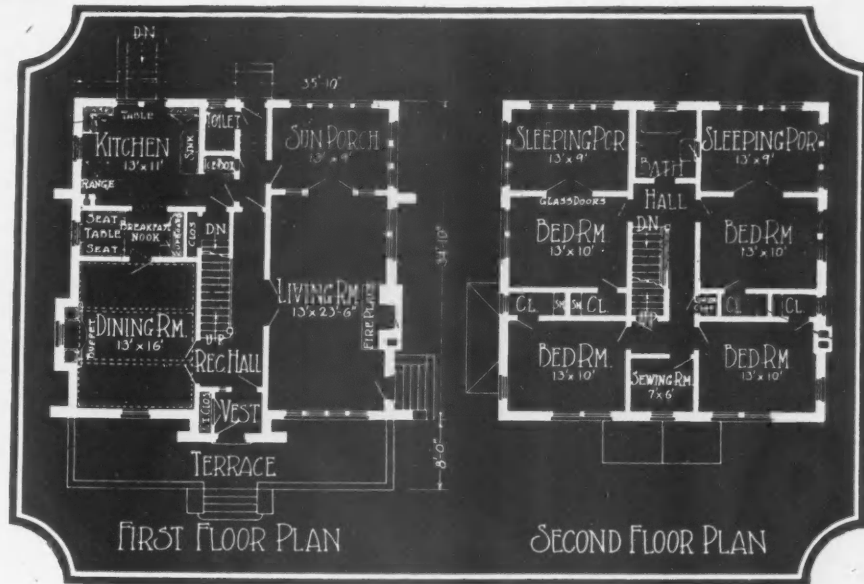

ATTRACTIVE SQUARE HOUSE WITH ORNAMENTAL HIP ROOF. Substantial construction is the outstanding feature of this beautiful home. It has solid brick walls with a bright colored face brick finish and a hip roof covered with ornamental tile. In shape, it is practically square, 35 feet 10 inches by 34 feet 10 inches. The customary front porch is missing, its place being taken by a terrace of concrete with low solid brick railings. The details of the doorway have been worked out artistically. Casement windows provide light for the splendid large living room, 13 by 23 feet 6 inches; regular sash are used elsewhere. There are seven rooms, one sun porch on the lower floor, and two sleeping porches on the second. A small breakfast nook with permanent furniture has been built between the kitchen and dining room to be used as handy substitute for the large room. There is a garage in the rear.



Apartment Buildings of This Size, Contrary to Popular Belief, Are Ideally Adapted to Co-operative Ownership. Many People Are Buying Flats in Lieu of Houses. These Ventures Have Proved Very Successful in Many Cities.

Co-op Apartment Building—How It Is Done

ONE OF THE MOST DESIRABLE FORMS OF HOME-OWNERSHIP AVAILABLE—OVER \$400,000,000 IN CO-OP. APARTMENTS IN NEW YORK CHANGED HANDS LAST YEAR.

IF you don't want to build a house, build a flat! You will not regret it, according to Albert W. Swayne, Chicago realtor, who has made a specialty of co-operative apartment buildings.

"From an investment standpoint," says Mr. Swayne, "I feel safe in saying there is no other form of home ownership which affords as good a return on the investment as an apartment in a co-operatively-owned apartment building. In addition to saving the profits accruing to the owner of a building under individual ownership, there is also a saving in cost of operation which will average over 6 per cent a year for the full value of the property."

Many items of loss and cost of upkeep which the individual house owner must take care of are not met with in the co-operative apartment scheme. For instance, renting and managing expense, vacancies, loss of rents, waste in decorating, abuse of building, etc. These items alone often exceed 25 per cent of the total rental value of the building.

A practical example is given by Mr. Swayne. A four-room apartment building in Chicago was recently sold under this plan. As compared with the rental of this same apartment over a period of five years, Mr. Swayne submitted these figures:

RENTAL PLAN	
Rents, five years, at \$75 a month.....	\$4,500
CO-OPERATIVE PLAN	
Initial purchase of stock.....	\$1,800
Estimated assessments, five years.....	2,587
Total outlay	4,477
Cash saving	\$ 23

Book value of stock, end five years.....	2,849
Net profit under co-operative plan.....	2,849

In other words, instead of having rent receipts totaling \$4,500, and not worth the paper they are written on, after five years, the flat owner will be \$2,849 ahead with a home and independence assured.

Of course, in swinging a proposition of this kind, the human nature element assumes an important part. Next to the actual selling of the idea, the vital point lies in the character of the people who want to become tenant-owners.

First, a building corporation is formed and a suitable building selected or plans for a new building accepted. The capital stock is ordinarily the equivalent of the equity to be purchased, which means it is fully paid up and invested in the building, which the company owns subject to fixed mortgages to be paid off by revenue derived from other sources.

"It is necessary to have a cash reserve of \$2,000 to \$3,000," says Mr. Swayne, "which is created by means of paid in surplus from the stock at slightly above par—this to provide against emergency expenses."

The entire capital stock is then apportioned among the apartments and the relative value of each flat expressed in shares of stock. The value of these shares for any flat represents the investment required to qualify for the co-operative plan. This apportionment is made in the by-laws and stays fixed.

The owner of the required number of shares is then entitled to a special stockholder's lease. This is issued by the corporation on approval of the directors. In this



Five-Room Apartments Seem to Be the Popular Unit in the Co-Op Apartment Ownership Plan. A Yearly Budget Takes Care of the Operating Expenses and Each Owner Pays His Share.

Co-operative ownership has proved very popular in New York city, where over \$400,000,000 worth of property changed hands last year on this basis. New buildings are being built with this idea in mind.

The big problem of the builder or architect in constructing a co-operatively-owned apartment is to build so that every one can have equal light and conveniences and will be satisfied.



The Yellow Stain on Hardwood

A TROUBLESOME defect often found in hardwood lumber is that recognized as yellow stain. It is usually distinguished by a pale yellow color, occurs generally in streaks, and is detected most easily when the wood is surfaced, altho

way control over the sale and transfer of stock is exercised and it is kept out of undesirable hands. The lease also establishes the means of fixing the rent to be paid, and to provide methods of assignment and sub-letting of apartments. The new party must be acceptable to the directors and buy the old stockholder's shares. Sub-letting is also controlled in this way.

Operating cost is then divided, according to Mr. Swayne.

"Instead of a fixed rent, the cost of operating is divided up among the owners each year, using the number of shares or number of rooms as the basis for determining each one's share."

A yearly budget is an essential feature of the plan, providing for janitor hire, taxes, repairs, etc. The total is apportioned and a so-called assessment levied on each apartment for the proper portion, payable in monthly installments in advance. The matter of interior decoration is not included, but is left to the individual owners, who can do what they please at their own expense.

"In event the estimate falls short of actual needs," points our Mr. Swayne, "the directors may draw on the surplus, replenishing it out of next year's assessment. Officers of the corporation serve without pay."

The co-operative idea has worked out with large and small apartment buildings, altho the larger ones prove more satisfactory. The expense of handling the smaller type amounts to practically as much as that of a larger one. The great demand is for five-room apartments.

at times it is present without any discoloration of the wood. Its first symptom may be a moldy appearance of the wood. Yellow stain has been observed by the Forest Products Laboratory in hickory and maple tool handles, in birch veneer, and in oak airplane propellers and wheel spokes. It is classified in the *Pencillium divaricatum* group of fungi, and resembles one of the fungi which damage wood pulp.

The only damage that yellow stain is positively known to do is to mar the appearance of the finished product, since it usually penetrates the wood so deeply that it cannot be surfaced off. It is probable, however, that the fungus actually weakens the wood, and the use of yellow-stained lumber for airplane construction or similar purposes where strength is important is to be discouraged until more is known about the action of the fungus on wood structure.



Over \$400,000,000 Worth of Property in New York Changed Hands Last Year on the Co-Operative Basis. This Amount Included Not Only New Buildings, but Many Old Ones. The Buying Is Done by a Corporation Composed of the Various Tenants.

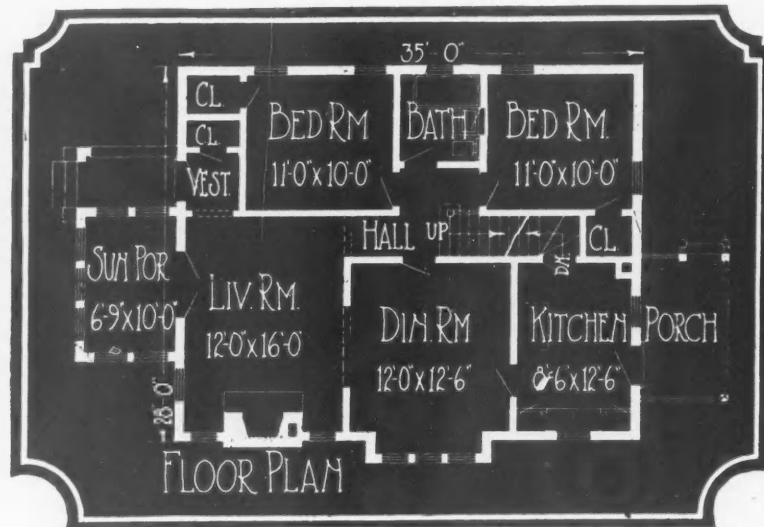
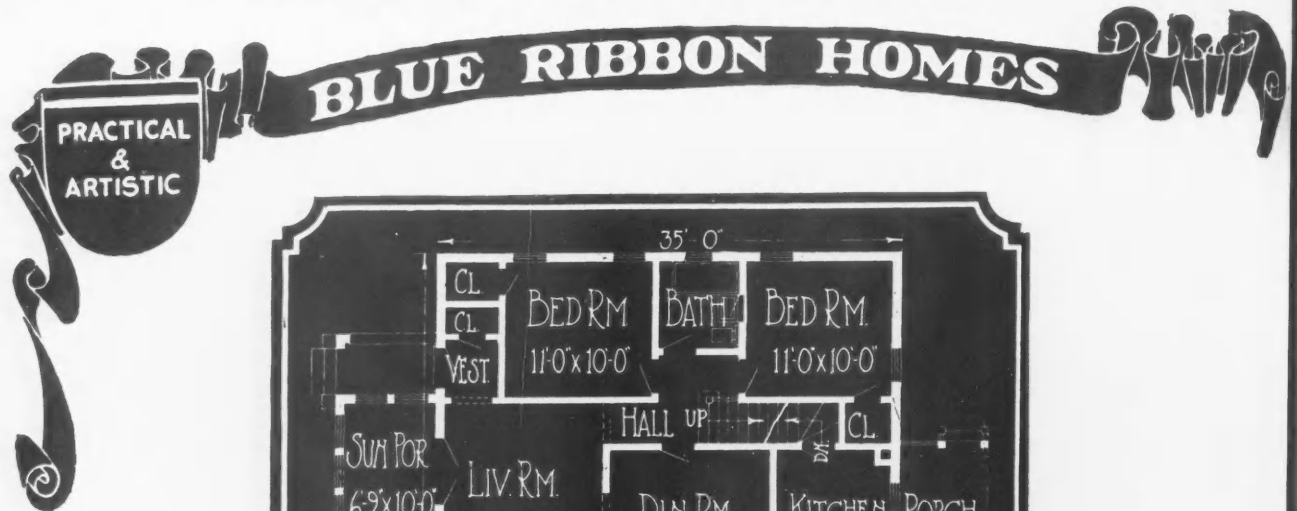

COZY BUNGALOW WITH ENCLOSED SUN PORCH. A small but "nifty" little home with bright exterior of stucco and foundation of concrete blocks finished with a coat of stucco along the front of the building. This charming home is just large enough to provide five rooms of good size, by no means "skimpy," and a small sun porch enclosed with glass and 6 feet 9 inches by 10 feet. The front entrance and landing has been recessed under the front wing roof. The door opens into a small vestibule, to one side of which is the living room, 12 by 16 feet. The room has a fireplace which can hold a gas mantle or burn real wood as desired. Dining room and kitchen follow in direct order, both rooms of light and good proportions. On the other side of the house are the two bedrooms, 11 by 10 feet each, with bathroom between, these three rooms opening into a short hall. The house is 28 by 35 feet.

BLUE RIBBON HOMES

PRACTICAL & ARTISTIC

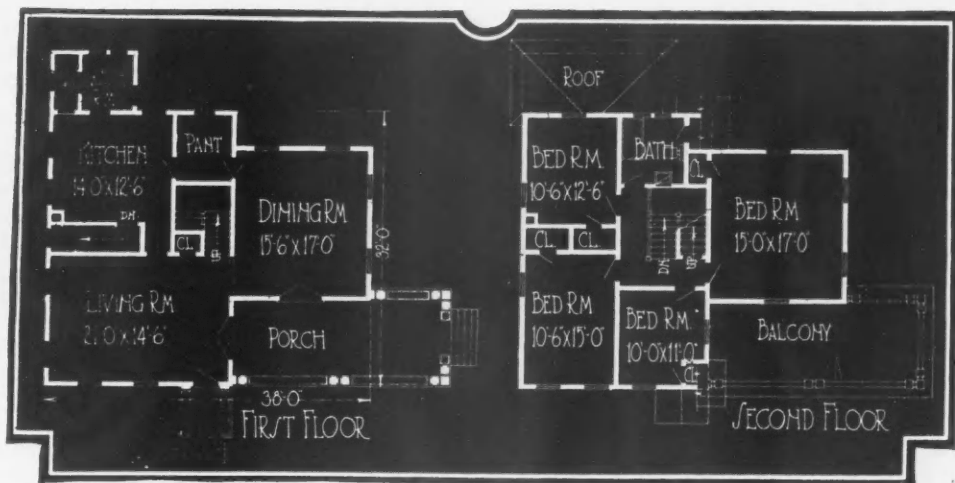

INFORMAL COMFORT IS FEATURE OF THIS HOME DESIGN. Large porches and rambling lines make any home appear hospitable and comfortable. This could very easily be used as a farm home because of its splendid adaptability to garden background. There is strong appeal in the large porch extending about half way back along one side of the home. Above is a broad balcony with railing. Entrance to the house is afforded thru this porch and thru a side entrance. Living and dining room both open on to the porch thru French doors, the former room, 14 feet 6 inches by 21 feet, the latter 15 feet 6 inches by 17 feet. A kitchen 14 by 12 feet 6 inches completes the first floor plan. Four bedrooms and bath make up the second floor plan. All bedrooms have two side exposure. Shingles have been used as exterior siding with a brick foundation. Size, 32 by 38 feet.

The Arch—Past and Present

SOME OF THE CHARMING INDOOR POSSIBILITIES OF THIS ARCHITECTURAL FEATURE.

By Marion Brownfield

LIKE other features of period architecture and interior decoration, the arch is being revived. It has equal charm for the palatial hall, the cozy living room or the simple bedroom, and can be effectively employed with doors, windows and ceilings.

To harmonize the arch with its surroundings, and give it the proper setting, it is worth briefly reviewing its history. The arch, indeed, has been almost a universal favorite with builders from a very ancient period. Some of the earliest arches discovered are those built in India nearly a thousand years B. C. These arches were "horse shoe" like the typical Moslem arch that was shortly after much used in India, due to the Moslem conquest. Whether the Moslems introduced the arch into Egypt has been questioned. It already existed in Assyria in both circular and pointed form. But the Egyptian arch was scarcely an arch as it was formed by the junction of two stones pointed toward each other from the tops of pillars. The Arabians had three different forms of arches, besides the circular arch, and used them in arcades, doors and windows. The horse shoe arch, already mentioned and which consists of a larger segment of a circle than a mere semicircle, was the characteristic Moslem arch, and was subsequently used in the Moorish architecture of Northern Africa and Spain due to the Moslem expansion. In buildings these arches were used rather fancifully, rather than systematically. Yet the result was artistically pleasing as a rule. Resting on either pillars or piers the corners were adorned with half columns. Probably for lack of engineering knowledge the arch was not applied to vault large spaces such as ceilings and roofs as in the later Gothic style.

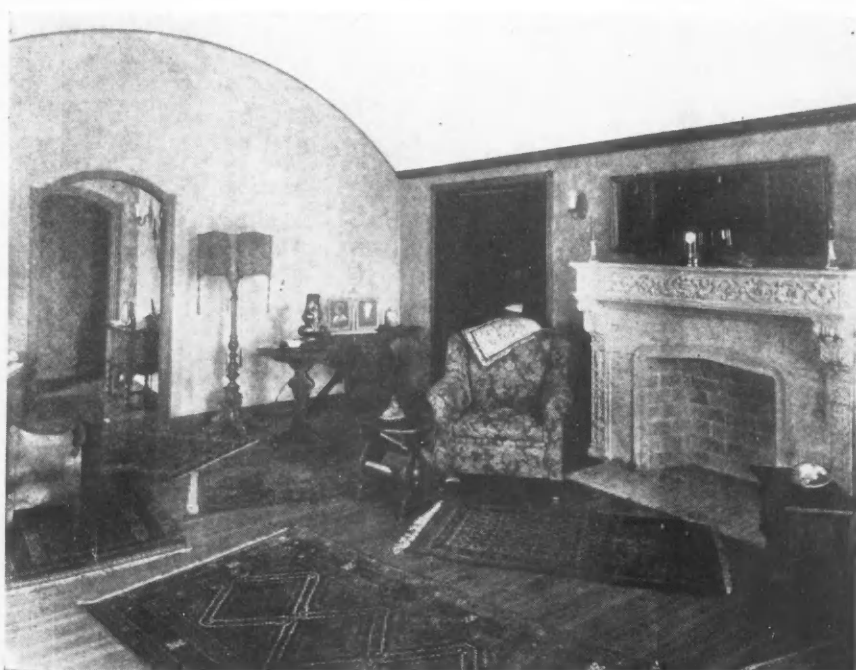

The Beauty of Simplicity Both for the Arched Doorway and Ceiling Is Illustrated in This Cozy Living Room. Even the Fireplace Conforms in General Lines

The Greeks very seldom used the arch. But the Romans used it to such an extent that they are often credited as its creator, and the arch called the Roman contribution to architecture. They learned, however, of its construction from the Etruscans, the ancient inhabitants of Italy, and being a practical people first used it for utilities such as aqueducts and bridges.

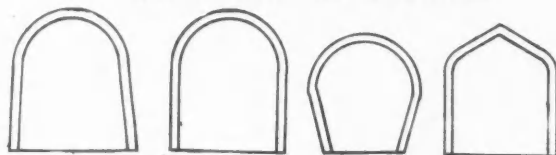

STILTED ELLIPSE HORSESHOE SEGMENTAL

Various Types of Arches Used in Architectural Design. There Has Been a Noticeable Revival in the Use of Arches, Especially in Interior Treatment.

But as Rome's magnificence grew the artistic value of the arch was perceived. The cylindrical dome and cross arch were Roman developments. With the Romans the important feature was the joint use of the column and arch because this led, eventually, to the elimination of the beam and arch. But it still was not developed to form complete structures. The difference and improvement of the "middle age" arch being an arch that was a consecutive whole, instead of requiring the support of pillars. The Romans developed attractive arch decorations which were later revived by the craftsmen of the Italian Renaissance. These consisted of sunken panels of various shapes "with rosettes and colored devices." There were also smooth finished arches that were painted. Gay colors also decorated Moslem arches in great profusion, but the gaudy was avoided by restricting each color in a complicated design to a small unit.

As the Romans next conquered so much of the then known world the semi-circular arch spread. It was the breaking up of Roman domination that gave us the many modifications of the arch that we have

today. The transition styles of the tenth to the twelfth century were known as Romanesque.

The Gothic period of architecture, which followed, was essentially a "pointed and perpendicular style" and the Gothic arch is thus early recognized. Gothic architecture was also very largely a cathedral style and its special feature was that decoration was closely allied with the construction. The arch applied to the roof resulting in a vaulted ceiling—now a popular revival for "Old English" style homes—was invented by necessity. The arch now instead of being supported by mere pillars, rose with the walls themselves buttressed by molded piers. The arch in English architecture literally became vaulted ceilings and roofs, altho arches were used for external openings such as doors and windows and were further developed. Rich mouldings, for example, outlined the arch for emphasis. The church doors of middle age cathedrals are notable for this effect and are of decided inspiration for the designer capable of modifying their lines to the simplicity suitable for good taste in domestic architecture.

The English Gothic merged into the Tudor style, and the characteristic Tudor arch was a five-centered, flat-pointed one, that was much used for homes as well as churches. The Tudor is often called the "modified arch."

Of great interest, now, is the Renaissance movement which affected Italy, Spain, France and northern Europe, and consequently the arch. With Italian architects the arch was a great favorite. A renewed study of the classic Roman arch tended at first to a beautiful simplicity of outline and examples of the arched treatment of doors and windows are seen today in historic palazzios and villas. The French and modern American productions of homes in the Renaissance styles invariably suggest the arch at the top of doors and windows. But with the Italians design frequently outdid construction. Frescoes and sgraffito decorated the spandrils between, as well the vault above, which afforded such backgrounds for the beautiful work of master painters like Raphael. English Renaissance effects included the more neutral wood and stucco as decorations for the arched ceiling.

The modern tendency of the arch, due to up-to-date methods of steel and reinforced concrete construction, is to make the arch a structural part of the building itself. This also tends to eliminate excessive decoration and make the arch itself, just because of exquisite proportions, a thing of beauty. An arch that cannot stand alone, except for the girder above it, is frowned upon by the modern builder who has sufficiently mastered his materials to unite art with good construction.



Vaulted Ceiling Much Modified with a Gothic Coving That Undoubtedly Lends Distinction to This Sleeping Room. This Was Borrowed from the Old Spanish Mission Architecture.

The reproduction of the Spanish-American arch as exemplified in the missions of the Southwest, for domestic architecture, reveals the charm of simplicity. Borrowed from the patio, for the interior of the home, the arch is equally effective. Opportunities for arched corridors, stairways, nooks, and alcoves are alluring.

The uses of the arch for doorways, windows and ceilings are illustrated here. The full value of simplicity can be appreciated with the arches shown in photograph 1, as no other wall decoration is allowed to mar the harmony of ceiling and doors on this side of the room. The fireplace, here, too, repeats the suggestion of an arch in the flat topped Tudor style. In photograph 2 the Gothic arch is applied to the coved ceiling in a way that gives distinction to this sleeping room. This photograph also shows how the Gothic style formerly thought only suitable for cathedrals, properly modified becomes cosily domestic.

The most important consideration in using the arch indoors artistically, is to harmonize it in period with the general style of the room, and with other lines such as the wood trim, other doors and windows, ceilings, cupboards and even the fireplace. As the arch makes a wide opening possible, with a maximum of grace, its value for breaking the monotony of the wall—especially the plaster one—is rapidly becoming realized.



Copper Salts Improve Casein Glue

IT has been found that copper salts added to casein glues greatly increase their resistance to moisture and also make the mmore durable when exposed to the action of molds and fungi. Casein glues containing copper are nearly as moisture resistant as blood albumin glues.

Glues containing little lime are especially improved by the addition of copper.

BLUE RIBBON HOMES

PRACTICAL & ARTISTIC

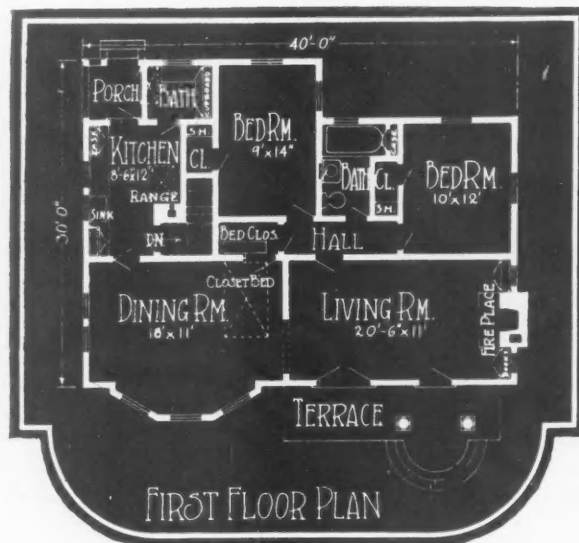

SMALL BUT DISTINCTIVE BUNGALOW DESIGN. The bungalow borrows indiscriminately from old established types and with much success. For instance some of the charming features of the Colonial have been used in this design. The front entrance is of this type, simple, but artistic and inviting. The plain white siding partakes of the character of the Colonial and the small paned windows also. There is nothing ornate about this design, consequently no likelihood of extra expense. The room arrangement is such as will appeal to the average housewife. Dining room and kitchen are located close together and the two bedrooms have been grouped away from the other rooms. The living room is 20 feet 6 inches by 11 feet with fireplace and wall bookcases. A closet bed has been built in the dining room, giving the house the advantage of three bedrooms without extra space. Size, 30 by 40 feet.

PL
used
broad
are b
by 15
rather
are 10
by 42

BLUE RIBBON HOMES

PRACTICAL & ARTISTIC

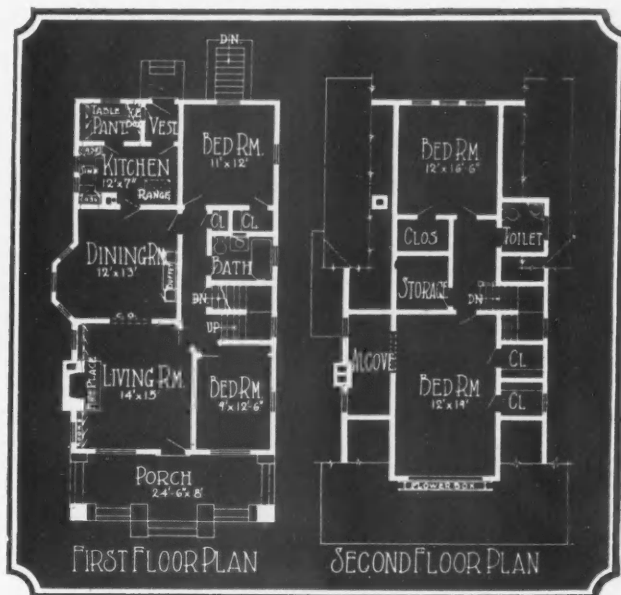

PLEASING COTTAGE DESIGN WITH NATIVE STONE TRIM. In many localities advantage can be taken of the abundant supply of natural stone in building homes. In this attractive little dwelling stone has been used in the construction of foundation, porch columns, railings and chimney. The building proper is frame with broad front porch. It is designed for the requirement of a good-sized family, having seven rooms, four of which are bedrooms. No space is wasted on vestibule, the front door opening directly into living room. This room is 14 by 15 feet with fireplace and wall bookcases. Dining room and kitchen are placed in rear of the living room. A rather long central hall connects front and rear bedrooms as well as the other living rooms. Two larger bedrooms are located on the second floor, the front room, 12 by 19 feet, the rear 12 by 16 feet. Size of house, 24 feet 6 inches by 42 feet.

estab-
n used
kes of
conse-
wife.
other
n built

Law for the Builder

RIGHT OF CONTRACTOR TO WITHDRAW BID ON PUBLIC WORK AND RECOVER DEPOSIT BECAUSE OF MISTAKE IN AMOUNT NAMED IN HIS PROPOSAL.

By Leslie Childs

GENERALLY speaking, the letting of contracts of a public nature by cities, towns, and other municipalities, is governed by law. The latter usually describes the mode and manner of calling for bids, gives a rule for the fixing of a deposit, along with other regulations relative to the opening and acceptance of bids. And, in this connection, a provision frequently met with in statutes of this kind is one which declares that when a bid is filed it shall be irrevocable, and if the successful bidder fails to execute the contract he shall forfeit the amount he deposited when his bid was submitted.

This provision of such statutes has been the subject of considerable litigation brought about thru the attempted withdrawal of bids for various reasons. But, in the absence of unusually good reasons, it has generally been enforced, and once a bid was submitted the contractor has been refused the right to withdraw it even tho it work a forfeiture of the amount he had deposited. This point of building law is one of special importance to contractors, who specialize in public contracts, and the general rule followed by the courts in situations of this kind is illustrated in a clear manner in *Baltimore vs. Robinson Construction Company*, 123 Md. 660, under the following facts.

The City of Baltimore advertised for bids for the construction of a schoolhouse, and the J. L. Robinson Construction Company, among others, submitted a proposal. The latter, as required by law, was accompanied by a certified check for \$500, as a deposit of good faith that in case the bid was accepted the contract would be executed.

On the day the bids were to be opened the president of the construction company informed the board that he thought his company had made a mistake in the bid submitted, because he had learned that its bid was so much lower than others submitted. Permission was asked to withdraw the bid, but this was refused, the bids were opened, and it was found the construction company's bid was \$14,000 lower than any other bid.

Contractor Made Mistake of \$11,000 in Bid

Thereafter it was found that in making the general tabulation the construction company had allowed \$952.13 for heating and ventilating, when it should have been \$11,952.13, which made the bid \$11,000 less than it should have been. The board, however, awarded the construction company the contract, the latter declined to sign it, and the board then declared the \$500 that had been deposited forfeited. The construction company thereupon filed the instant suit to recover the \$500 deposit.

The case reached the Maryland Court of Appeals, and its determination required a construction of the

Maryland statutes that governed the letting of contracts by the City of Baltimore. The statute provided, among other things, as follows:

"Bids when filed shall be irrevocable. * * * To all such bids there shall be attached a certified check of the bidder upon some clearing house bank, and the bidder who has had the contract awarded to him, and who fails to promptly and properly execute the required contract and bond shall forfeit such check. The said check shall be taken and considered as liquidated damages, and not a penalty, for failure of said bidder to execute said contract and bond.

"In the face of these provisions can a bidder, refusing to execute a contract awarded to him for municipal work, force the return of his deposit, or once having filed his proposal, can he withdraw it before

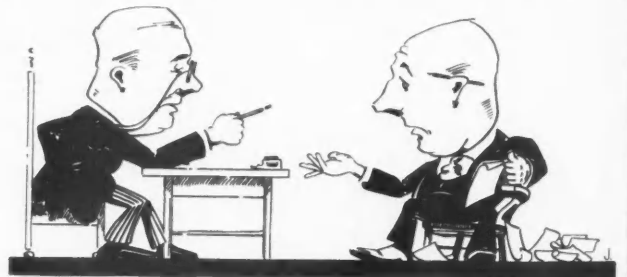

"Bids When Filed Are Irrevocable." The Contractor Could Not Recover His \$500 Deposit.

the bid is accepted and recover his deposit? It will be noticed that, in plain terms, the section directs that the bidder shall deposit a certified check to indemnify the city in case he, as successful bidder, fails to execute the contract and furnish a bond; that bids when filed are irrevocable; and that the contract shall be awarded to the lowest responsible bidder. It certainly must be that there was the intention that these explicit directions should have some force and meaning. We must ascribe a reasonable construction to them or we render the statute a mere nullity. These provisions involve the preliminary steps to the making of the contract for the work to be done. * * *

Deposit Check Held Forfeited

"This may seem a hardship upon a bidder who has actually made a mistake, but if the statute is to have any effect, that must be the result.

"After the bids were all in, and before the bids were opened, this appellee easily ascertained from his competitors the amounts of their bids. What would there then be to prevent a dishonest bidder, upon finding that his bid was extremely low, from declaring that he had made a mistake, and thus put the city to the cost of delay and re-advertising? * * *

The Court of Appeals thereupon ruled that the company was not entitled to have the \$500 refunded.

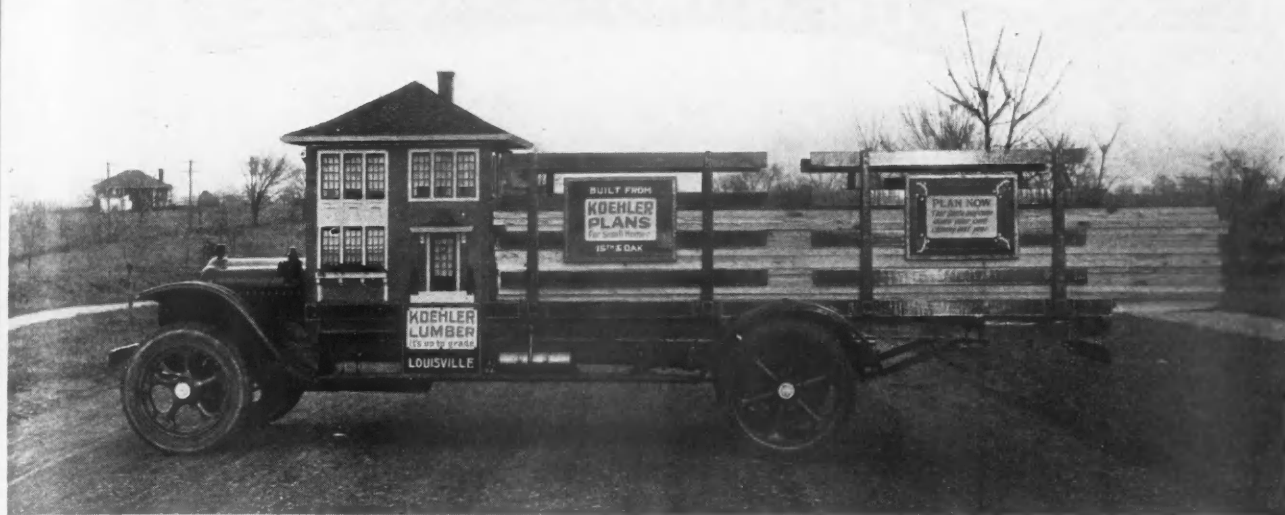

View of Entire Truck Showing Unique Cab in Position. This Stunt Has Attracted Considerable Attention and Has Proved to Be an Effective Advertising Medium.

Advertise the Building Business

HOW ONE PROGRESSIVE LUMBER COMPANY KEEPS THE IDEA CONTINUOUSLY BEFORE THE PUBLIC

WHEN some one asked William K. Wrigley, Jr., how he achieved such remarkable success with chewing gum in such a short time, he answered in one word:

"Advertising."

He has hammered home the idea by every means possible until millions know his products.

Some builders do not think that the idea holds true of the building industry. They are from Missouri with the rest of the "show-me" boys. And "they are going to be shown."

Says the Koehler Lumber Co., of Louisville, Ky.

Down there they talk building, eat building and sleep building. There is nothing else on their mind. And they want every one else to think the same.

Every day the Koehler trucks made the rounds of the city but attracted no more than passing notice. What to do? And then the idea came.

They designed a truck cab which is an exact replica of a modern English type house, brick, stucco and frame, and everything else that goes into a house. The pilasters and chimney are of imitation tapestry brick of four shades, laid with white mortar and cut out joints. The foundation shows a soldier course of such brick.

The walls are covered with crushed stone stucco. The windows on the sides have real frames set in the wall, with separate French sash of fifteen lights each. The doors are divided in like manner. Under the door canopy is an electric light to which current is furnished. The flower boxes hold evergreen shrub plants with some color intermingled, while at each side of the door is a miniature cedar tree in a tub. The roof shows a break which does much to add to the architectural beauty of a hip roof. The roof is covered with miniature blue slate asphalt shingles.

The down stairs windows and doors are draped with pongee curtains and plisse shades which openings are sealed on the outside to keep out the dirt. The walls are gray stucco, brick tapestry in reds, browns and yellows, outside finish, and frames painted cream, steps white stone, sash and doors green.

The driver enters thru a door taking up about one half the side of the house and hung on hinges (see smaller illustration) and looks out thru windows in the front of the cab. This has proved to be a real sensation in the city and is attracting so much attention and stimulating such interest in home-building, that The Koehler Company has received many requests from other firms to build cabs of this type for their use.



Close up of Driver's Cab Built to Resemble a Complete House in Miniature. The Driver Enters the Door on This Side Hung on Hinges. The House Is Covered with Stucco and the Roof with Miniature Blue Slate Asphalt Shingles.

BLUE RIBBON HOMES

PRACTICAL & ARTISTIC

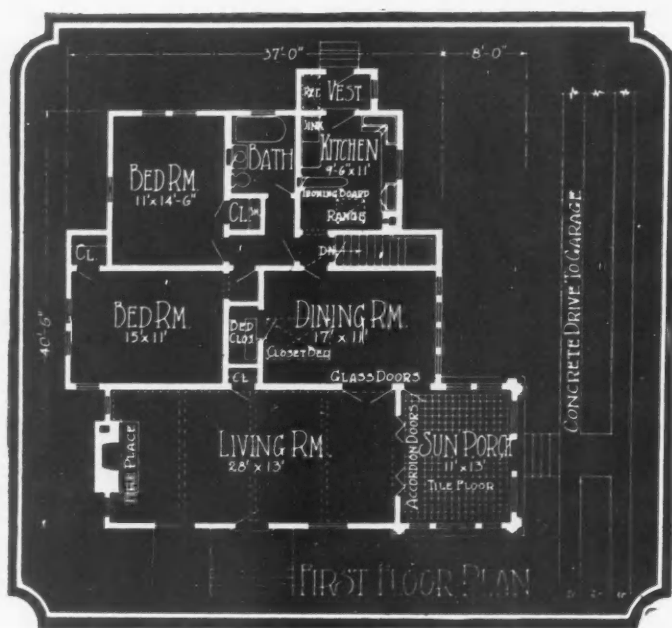

COZINESS PREDOMINATES IN THIS CHARMING HOME. Particularly appealing and attractive is the glazed sun porch on one side. It is paved with large tile blocks of distinctive color, and connected with the adjoining living room by means of accordion folding doors. When these doors are folded back out of the way, the benefit of double expanse of room can be obtained. The house has an attractive stucco exterior with low hipped roof, the usual front porch being replaced by a low terrace of brick. A small hood covers the front door, which opens into the living room, 28 by 13 feet. When the sun parlor is open, there is a stretch of 39 feet unobstructed. French doors connect living room with dining room, 17 by 11 feet. A wall bed has been installed in this room for emergency. There are two regular bedrooms, opening out into a hall in the rear of the house. A kitchen and bathroom complete the floor plan. The bungalow is 37 by 40 feet 6 inches.

BLUE RIBBON HOMES

PRACTICAL & ARTISTIC

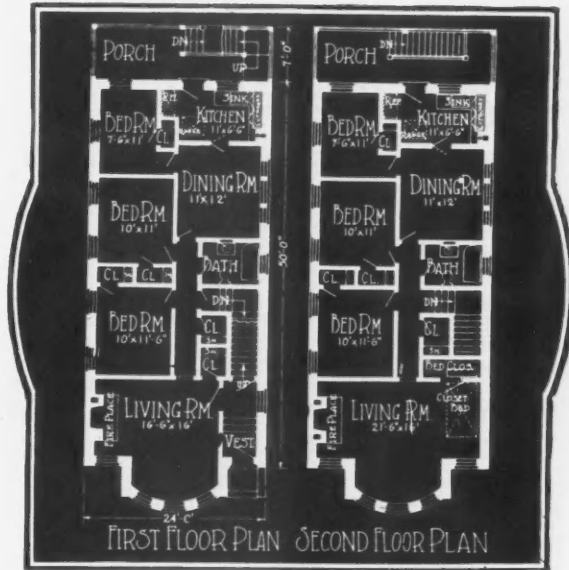

TWO-APARTMENT BUILDING—AN ATTRACTIVE INVESTMENT OFFERING. Here is a practical and pleasing house design that will find instant response from many home-builders. It offers the man of average means a home, modern in every respect, and a source of income to help him pay for his home, viz.: the apartment upstairs. This apartment brick house has two apartments of six rooms each, living room, dining room, kitchen and three bedrooms. The living room on the second floor has the additional space occupied by the front hall on the lower floor. This space has been used for a wall bed, giving the upper apartment really seven rooms. The construction is substantial throughout, solid brick walls with a face brick finish on the facade, and white stone trim. There is a high well-lighted basement for laundry, fuel storage and heating plants. The house is designed for the city lot and is 24 feet 6 inches by 50 feet.

DESIGN of SAFE CONSTRUCTION

By J. F. Mangold

Associate Professor of Mechanics, Armour Institute

Reinforced Concrete Pressure Tank

ARTICLE 20 OF AN EXTENSIVE SERIES OF STRENGTH OF MATERIALS

REINFORCED concrete is being used to an increasing extent in the construction of tanks and reservoirs. In most of the present day designs, all tensile stresses are resisted by the reinforcing steel, while the concrete serves to hold the steel in place, and provide impervious walls for the reservoir.

Since water tightness is highly desirable, a stress of ten thousand pounds per square inch is deemed good practice.

To illustrate some of these points, we will take up general features of the design of a pressure tank, eight feet in diameter and twelve feet deep. The water will be eight feet deep, with the remaining space an air chamber under a pressure of twenty-five pounds per square inch.

Consider the side walls, which will be computed for hoop tension. In a reservoir, the pressure per unit of area is proportional to the depth of the water. In this case the air pressure will be converted into a corresponding height of water column, by means of the expression $h = 2.304 p$. h is the depth of water corresponding to p , or $h = 2.304 \times 25 = 57.6$ ft. The air pressure is equivalent to fifty-seven and six-tenths feet of water. At the bottom of the tank the total pressure per square foot will be: $P = (57.6 + 8) \times 62.5 = 4100$ pounds, and the total pressure against a

vertical foot of wall will be equal to the pressure per square foot times the diameter. Then total $P = 65.6 \times 62.5 \times 8 = 32,800$ pounds. This pressure is resisted by two sections of the rim, and the hoop tension for the first foot of height of wall is $32,800 \div 2 = 16,400$ pounds. With a steel stress of ten thousand pounds per square inch, the area of steel required will be $16,400 \div 10,000 = 1.64$ square inches. To secure this sectional area, use three $\frac{7}{8}$ -inch round or three $\frac{3}{4}$ -inch square bars spaced four inches on centers.

On account of the constant air pressure there will be comparatively little change in the hoop tension from bottom to top. Hoop tension four feet below the water surface will be equal to $[(57.6 + 4)62.5 \times 8] \div 2 = 15,400$ pounds. The steel area needed will be $15,400 \div 10,000 = 1.54$ square inches per foot of vertical height of wall. To obtain this area use three $\frac{13}{16}$ -inch round or three $\frac{3}{4}$ -inch square rods, on four inch centers.

The hoop stress in the air chamber is constant and equal to $(57.6 \times 62.5 \times 8) \div 2 = 14,400$ pounds. Area of steel required is equal to $14,400 \div 10,000 = 1.44$ square inches. In order to get this area, use rods and spacing as before.

The soil pressure, due to the weight of the tank and water will be $62.5 \times 8 = 500$ pounds per square foot plus 1,500 pounds per square foot due to the tank. This total of 2,000 pounds per square foot is readily sustained by ordinary soil. The base should be given a thickness of 12 inches to assure a substantial footing and provide room for embedment of vertical steel. The base should be stiffened by placing two set of $\frac{1}{2}$ -inch rods at right angles to each other, on 12-inch centers, both near the top and bottom of the slab.

Air pressure causes a lifting force tending to shear the base from the wall along a vertical surface (see A-A, Fig. 1). The total pull is equal to $25 \times 144 \times \pi 4^2 = 181,000$ pounds. Then shearing force per foot of perimeter is equal to $181,000 \div \pi \times 8 = 7,200$ pounds. This force is reduced due to the weight of the wall and top. The weight of an 8-inch wall per foot of perimeter is equal to $\frac{2}{3} \times 12 \times 150 = 1,200$ pounds. With a 12-inch cover, the weight per foot of perimeter would be equal to $\pi 16 \times 150 \div \pi 8 = 300$ pounds. Total weight is equal to $1,200 + 300 = 1,500$ pounds. Then actual shearing force is 7,200 pounds minus 1,500 pounds equals 5,700 pounds. Unit shear will be $5,700 \div 12 \times 12 = 40$ pounds per square inch.

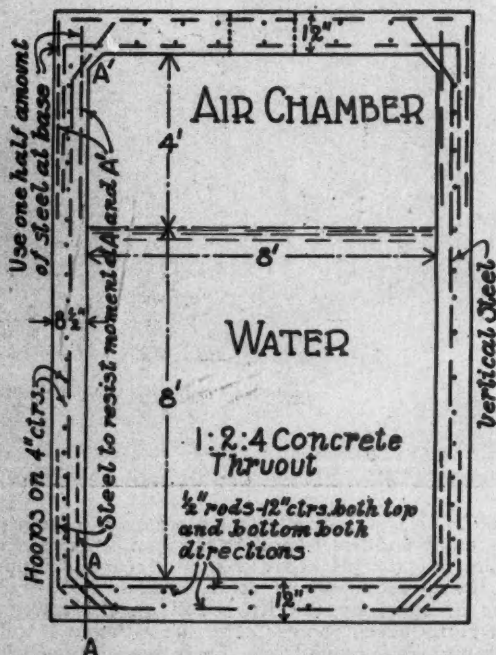

Fig. 1. Cross Section of Tank, Showing Air Chamber and Water Compartment. Note Variation in Reinforcing in Walls.

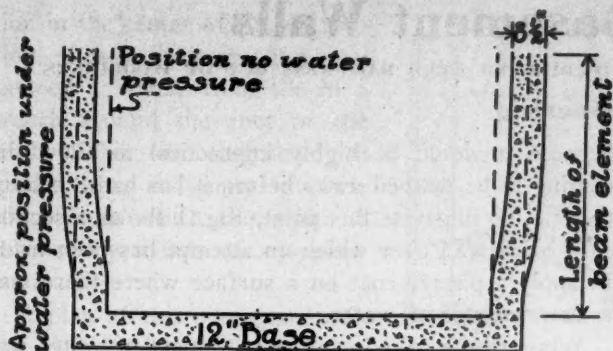

Fig. 2. Diagram Showing Deformation of Side Walls Under Water Pressure.

This stress is easily taken by the concrete.

The air pressure causes a longitudinal tension in the walls. The vertical pull per foot of perimeter is equal to $181,000 \div \pi 8\frac{1}{2} = 6,800$ pounds. It will be necessary to provide $6,800 \div 10,000 = .68$ square inches of metal. In this computation, it is assumed that the radius of the center line of the wall is $8\frac{1}{2}$ feet, which is on the side of safety. To provide the steel area required use $\frac{5}{8}$ -inch square rods spaced six inches on center around the perimeter of the tank. These rods form the vertical reinforcement and should extend from the base to the top with substantial embedment in each.

At the junction of the walls with the base it is impossible for the full hoop stress to be developed on account of the restraint offered by the base. At some distance above the base the necessary deformation to develop full hoop stress is realized. (See Fig. 2.)

The lower part of the wall might be thought of as made up of vertical beams fixed at the lower ends and gradually deflected until their extreme position corresponds to the deformed position of the shell when the full hoop tension stress is developed. In the theory of reinforced concrete is derived an expression in which the deflection of the imaginary beam is equated to the deformation of the hoop at full stress. From this relation is obtained the expression for

$$"l" = 8.16 \sqrt[4]{\frac{fsrd^3}{h \times 86}}$$

which gives the length of the beam element. fs = hoop stress; r = radius of tank in inches; d = effective thickness of wall in inches, and h = the head of water in inches. The moment is assumed as $M = Wl \div 8$ at the fixed end. Substituting the above value

$$M = 3.6 \sqrt{\frac{rd^3hfs}{86}}$$

Substituting numerical values in this formula,

$$M = 3.6 \sqrt{\frac{10,000 \times 48 \times 6.5^3 \times 56.6 \times 12}{86}}$$

then $M = 125,000$ pound inches.

With the usual percentages of steel the compression in the concrete would be excessive. Either it will be necessary to thicken our wall in excess of the $8\frac{1}{2}$ inches which is sufficient otherwise, or else introduce compressive steel. With compressive steel equal to

tensile, a condition which would relieve the concrete of stress, the area of steel required would be $As = 125,000 \div 10,000 \times 6.5 = 1.92$ square inches for tension and an equal amount for compression. To obtain this area use $\frac{7}{8}$ -inch round or $13/16$ -inch square rods spaced on 4-inch centers. These rods should be extended vertically above the base a distance of 36 inches.

The length of the element subject to the deflection as a beam is found to be 25 inches from the previous expression for "l." At this upper end of the beam element is assumed a moment equal to one-third of that at the base, and opposite in direction. This moment will be taken by the extended steel. One-half this amount of steel should be used at junction of cover with side wall.

There is a shearing force at the base expressed by the formula $V = .22hl$, where "V" is the shear per foot of circumference; "h" is the head of water in inches, and "l" is the length of the beam element. Substituting values: " V " = $.22 \times 65.6 \times 12 \times 25 = 3,940$ pounds. Then unit shear equals $3,940 \div 12 \times 6.5 = 50$ pounds per square inch. The section takes care of the shear without any further provision.

Since the tank under consideration is to be a pressure tank there must be a tight upper base firmly fixed to the walls. An inverted dome as the upper base has been suggested, but it would seem that the difficulties of constructing such a dome would far outweigh its potential strength. A dome with considerable rise, since it would be inverted would much reduce the capacity of the tank. Therefore it seems best to consider a flat slab.

The upper base will be a circular slab fastened to the walls by means of the vertical reinforcement previously computed. This base is a circular reinforced concrete slab or plate fixed at the perimeter. There is no satisfactory theory which will serve as a basis for the design of this cover as a circular slab, but it is readily computed by assuming strips

at right angles to each other, and analyzing them as beams, assuming that each one takes one-half of the moment it would be required to resist if the slab were considered as a series of parallel strips. The

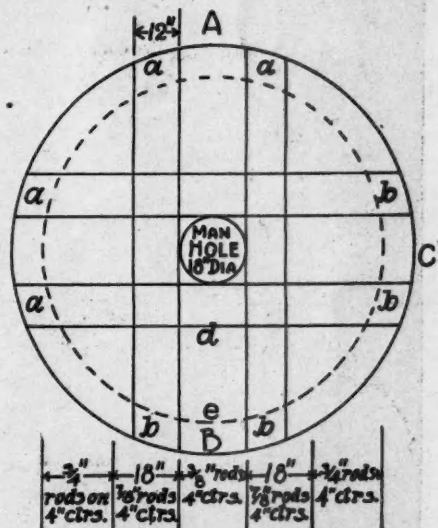

Fig. 3. View of Cover, Showing Division of Slab into Beam Elements for Purposes of Analysis.

(Continued to page 102.)

Waterproofing Basement Walls

HOW SPECIAL WATER PROOFED PLASTER COAT IS APPLIED TO KEEP DAMPNESS OUT OF BASEMENTS

By H. G. Doering

"OUT, damned spot!"

We do not believe Macbeth had plaster walls in mind when he uttered these well-known words, but perhaps Shakespeare, at the time he was writing the play, was suffering from rheumatism brought on by damp cellar walls. Whatever the cause of this outburst, there are many home owners today who feel just about the same when they take a trip thru the cellar of the homes they have just built.

Perhaps no other flaw in construction will irritate the home owner as much as damp basement walls, causing as they do dampness in the storage section and laundry and affecting inevitably the walls above the grade line. Other defects can be quickly repaired, but a damp wall is an inherent defect that defies the ingenuity and patience of any workman. It is a fault that should be prevented rather than removed, and if not nipped in the bud will cost money as well as discomfort.

The best thing to do is to practice the old doctrine of a "stitch in time." A properly applied waterproofed plaster coat on the inside walls of the basement will keep out moisture and prevent dampness.

While the application of this waterproofed coat is comparatively simple, nevertheless it is necessary to observe several important points.

In the first place the water pressure must be relieved during the application and setting of the plaster coat,

because it would be highly impractical to allow the coating to be washed away before it has had a chance to set. To illustrate this point, Fig. 1 shows a section of a brick wall over which an attempt has been made to apply a plaster coat on a surface where there was a slow seepage of water.

While to the naked eye the movement of water was hardly discernible, yet as soon as the green plaster



Fig. 1. Section of Brick Wall Over Which an Attempt Has Been Made to Apply a Surface Coat of Plaster Where There Was a Slow Seepage of Water.

coat was applied it began to be carried down on the thin film of moisture that slowly but positively collected in back of the plaster coat and separated it from its contact with the surface. The streaked appearance of the wall in the photograph illustrates this point. It was necessary to

insert the bleed pipe, as shown, to concentrate the flow of water before the plaster coat could be applied further.

It is evident, therefore, that proper provision must be made for taking care of water pressure on a surface to be plaster coated. In the case of basements this is sometimes done by the very simple expedient of taking a post hole digger and sinking a hole on the outside of the wall opposite the place where the seepage seems to concentrate. Then by pumping out the water the pressure is relieved sufficiently to allow the work to proceed.

However, for general purposes the most practical method and the one which is most generally used is by the insertion of bleed pipes thru the wall. An example of this is illustrated in Fig. 1 already referred to, and is shown again on a somewhat larger scale in Fig. 2. Holes were drilled thru the wall, into which the bleed pipes were inserted and the plaster coat applied. After thoro hardening of the waterproofed plaster coat the bleed pipes are broken off and closed by driving in pine plugs. Waterproofed cement can be applied over the plugged holes so as to give a uniform appearing surface.

A section of a wall showing how this idea of seepage is worked is shown in Fig. 3. To relieve the pressure on the wall at the left a hole has been drilled thru the wall into which has been inserted a pipe which is then made continuous with a sump or pit construc-



Fig. 2. Taking Care of Seepage. Bleed Pipes Are Inserted Thru the Wall and Then Plaster Coat Is Applied. After Thoro Hardening Bleed Pipes Are Broken Off and Closed with Plugs. Then Waterproofed Cement Is Applied Over Them.

tion in the center of the excavation. It also illustrates the erection of a 2-inch drain tile in a trench around the foot of the wall. This is constructed to grade so as to empty into the sump from which the water is relieved by means of a syphon pump.

A plan of this arrangement is shown in Fig. 4. It is important to note how the two bleed pipes are inserted in the wall which are connected with a syphon pump and the drain tile which is covered with cinders and gravel running continuously on the outside and connected to the central sump. With the flow of water concentrated to the sump or central pit in this manner, the surface is in condition

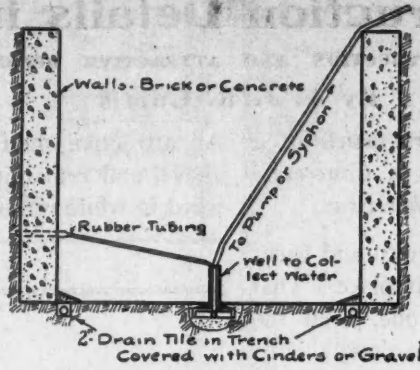
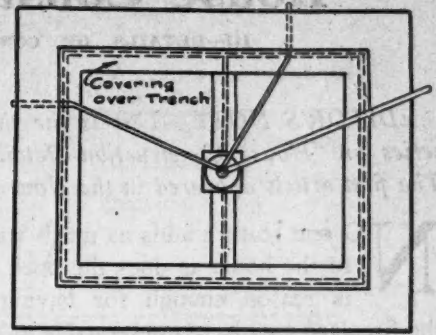

Fig. 3. Diagram of Section of Wall Showing How Seepage Is Worked Out. Drainage Tile Has Been Laid Along Bottom of Wall.



THE TRUSCON LABORATORIES - DETROIT -

Fig. 4. Plan of Same Arranged Showing Pit in Center of Floor with Bleed Pipes in Walls.

for application of the plaster coat. The bleed pipes should be left for a period of ten days or two weeks in order to insure the proper hardening of the plaster coat before it is required to withstand pressure.

Proper roughening of the surface for the plaster coat is of as much importance as relieving the water pressure from behind the waterproofed plaster coat while hardening.

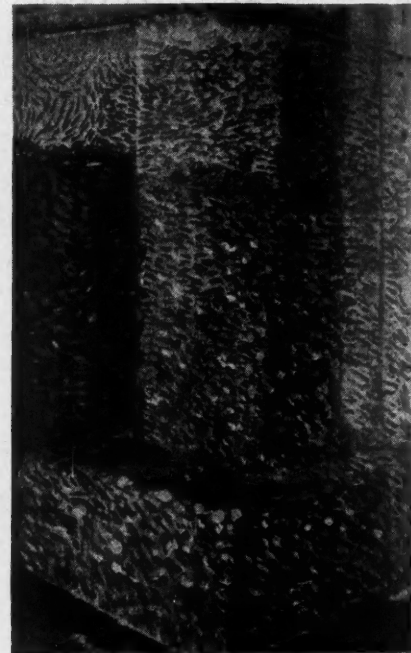

Fig. 6. How Roughening and Chipping Is Applied to Columns and Footings. This Roughening Process Is Flooded by an Application of Acid to Expose the Aggregate for the Plaster Coat.

Naturally it is more difficult to bond a plaster coat to a smooth surface than to a rough surface. For this reason the wall must be roughened sufficiently to give a good "key" to the plaster. In Fig. 5 is illustrated the manner of chipping and roughening a concrete wall. In Fig. 6 is shown how the roughening treatment is applied to columns and footings. In the case of a brick wall, pains are taken to rake out the mortar to a depth of fully half an inch in between the joints so as to afford the right kind of a bond for the plaster coat. A stone wall should be similarly cleaned and roughened (chiseled) previous to applying the plaster coat.

After the surface has been thoroly roughened it should be cleaned with a heavy wire broom to remove

all loose particles. If a jet of steam is available it should be used to clean the wall. The whole purpose of all this preparation is simply to be absolutely positive that the plaster is able to adhere securely to the wall without the slightest danger of becoming separated from it. Two coats of muriatic acid are applied to the clean wall with a large acid brush and allowed to remain there until it has exhausted itself. The aggregate is then sufficiently exposed for the plaster. After this is done the wall should be thoroly slushed with water until it is soaked. This will give the masonry wall all the water it can absorb and prevent it from robbing the plaster coat of its water. If the cement while setting is robbed of any of its water the result will be a poor job, usually soft, cracked or crumbly. This is often the case in an outside stucco job. After this soaking the grout coat is applied.

Greater care must be taken in the application of this special waterproof coat than in the application of ordinary plaster. The material should be firmly pressed and worked into all crevices and mechanical irregularities of the surface and then well floated. This is the part of the job that really requires some skill and experience. It can probably best be described by saying that the plaster coat must be "compressed" on the surface, as well as troweled, in order to give it the necessary density for thoro waterproofing results.

(Continued to page 168.)

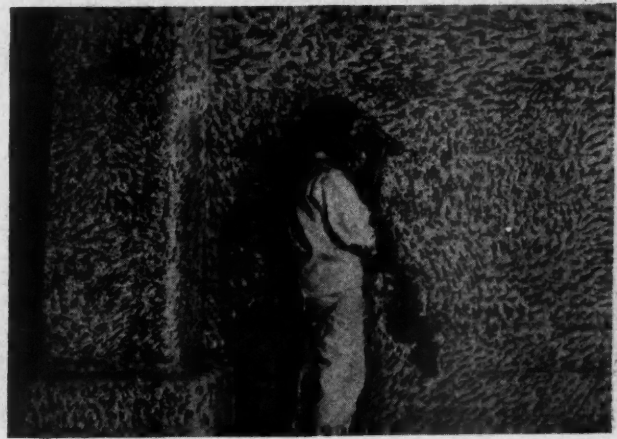

Fig. 5. Manner of Chipping and Roughening Concrete Wall. This Work Is Important and Necessary to Insure Adhesion of the Plaster Coat.

House Construction Details in Concrete

III—DETAILS OF CONSTRUCTION AND ATTRACTIVE DESIGNS OF FIREPLACES.

By A. J. R. Curtis

EDITOR'S NOTE—This is the third article of a series on "House Construction Details in Concrete." The first article appeared in the November issue.

NO one feature adds as much warmth and cheer to the home as does the open fireplace. That is reason enough for having one, even tho the fireplace may have questionable value along side of modern heat appliances, and as a dispenser of light is not in it with the incandescent bulb. But the fireplace has a secure place as a living room ornament in Amer-

ican homes so long as the stories of pioneer days are retold and St. Nicholas continues to make annual trips down the chimney. Put a fireplace into your house plans and provide your home with a cheer center.

In the concrete house, at least, the fireplace structure should be of concrete,

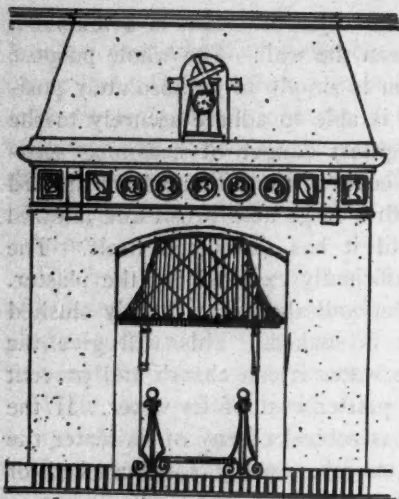

Fig. 3. Concrete Block Fireplace Faced with Tapestry Brick Moulding with Frieze Above.

probably using fire brick lining, and colored brick, tinted stucco or cast stone on other surfaces.

Fig. 1 shows the fireplace in the monolithic concrete residence of Arthur E. Butler, Syracuse, N. Y. The area surrounding the rectangular opening is cased with red tapestry brick laid in white cement mortar.



Fig. 1. Fireplace in Monolithic Concrete Residence with Casing of Tapestry Brick and a Shelf of Concrete.

An attractive shelf is formed by a slab of concrete above, and remaining portions of the surface are finished in white cement plaster, sand float finish, directly

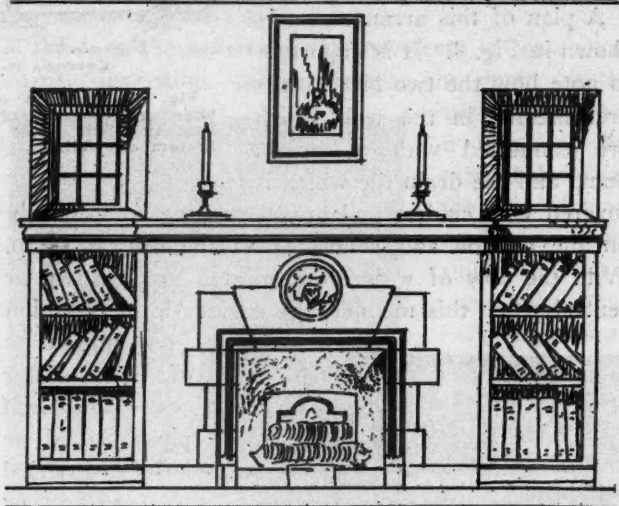

Fig. 2. Fireplace Design Featuring Concrete Stone in Framing Around Opening.

to the concrete structure. The design is simple and pleasing.

Several attractive designs, prepared for concrete houses by leading Minneapolis and St. Paul architects, are shown in following illustrations. Fig. 2 is a design by J. R. Corwin of St. Paul, featuring concrete architectural stone,

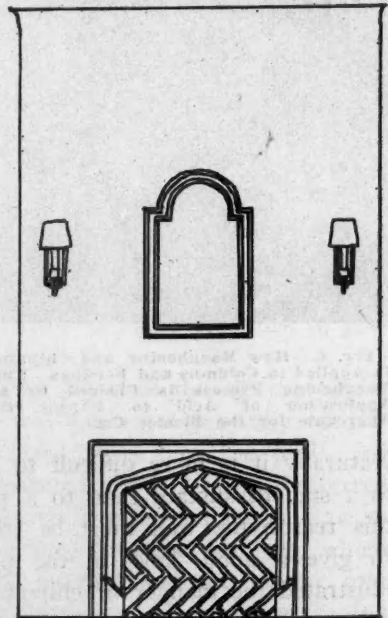

Fig. 4. Art Stone is the Material Used in This Little Design. Note the Unique Firebrick Lining.

which forms an attractive beading and framing around the opening. The remainder of the fireplace structure is of concrete block, covered with tinted sand-float cement plaster. The very attractive and quiet unusual design shown in Fig. 3 is by

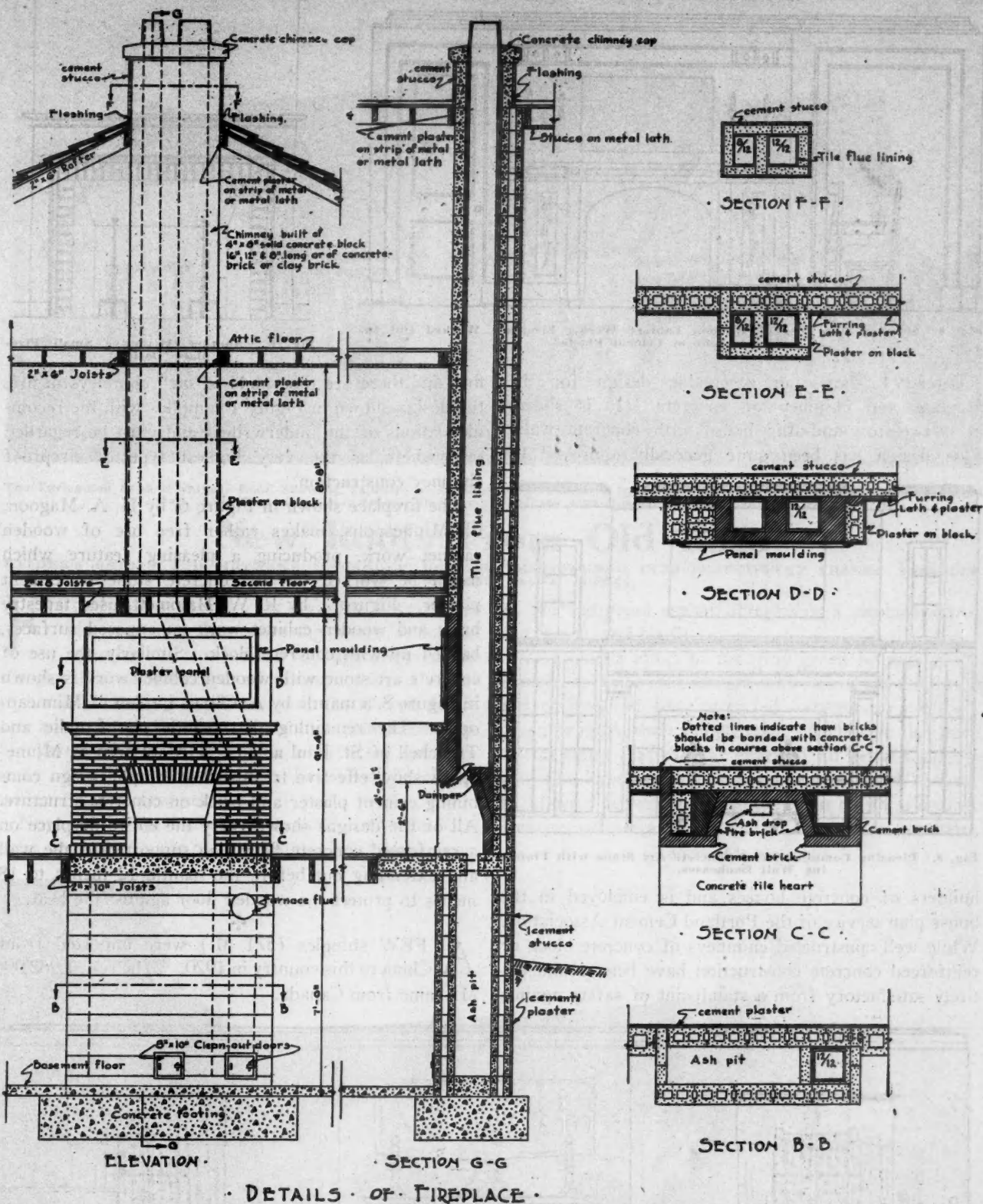

Fig. 5. Construction Details of Fireplace in Two-Story and Attic House with Concrete Walls. This Is Standard Practice.

C. G. Hinman of St. Paul. It is built of concrete block faced with moulding of red tapestry brick set on edge, a frieze of concrete art stone of colored terra cotta tile bearing a number of medallions, and sand-float finished tinted cement plaster. The canopy is of Russia iron on a wrought iron frame. D. H. Works, of Minneapolis, is the designer of the artistic little fireplace shown in Figure 4. It exposes a very sim-

ple, but rich, framing of concrete art stone surrounded by cement plaster, all of which is attached to a backing of concrete block. The fire brick lining is decidedly unique, the brick being laid up edgewise in a staggered oblique pattern. A concrete art stone frame above the mantle provides place for a mirror and two small art stone medallions are set in at the candelabra openings.

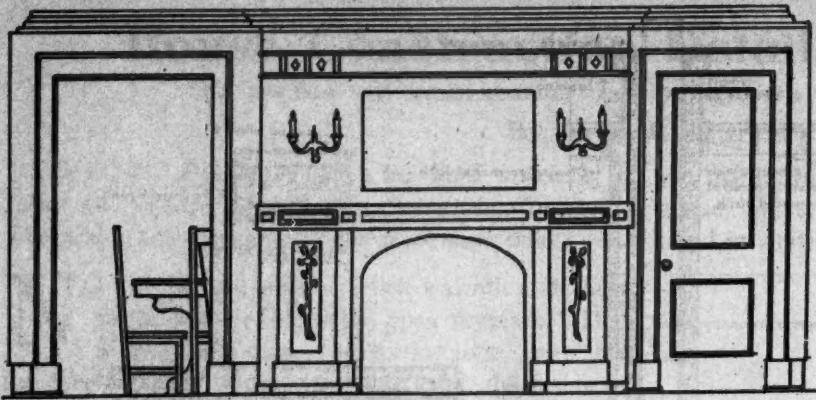

Fig. 6. Showing Free Use of Wooden Cabinet Work. Fireplace Worked Out in Concrete Stone or Cement Plaster.

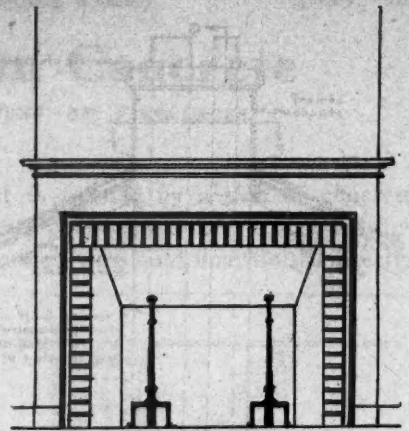

Fig. 9. Another Attractive Small Fireplace Design.

Figure 1 shows an acceptable design for the fireplace and chimney of concrete. It is shown in a two-story-and-attic house with concrete walls. This design has been quite generally approved by

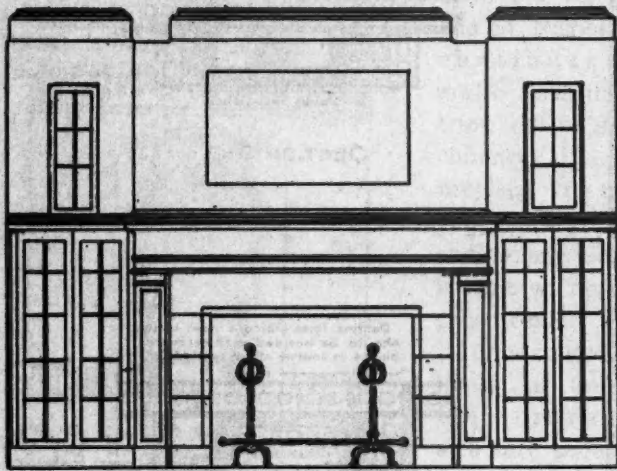

Fig. 8. Pleasing Combination of Concrete Art Stone with Flanking Wall Bookcases.

builders of concrete houses and is employed in the house plan service of the Portland Cement Association. While well constructed chimneys of concrete block or reinforced concrete construction have been found entirely satisfactory from a standpoint of safety against

fire, and there are thousands of such chimneys in use, the design shown in Figure 1 complies with the recommendations of the underwriters and must be regarded everywhere as the very highest type of fireproof chimney construction.

The fireplace shown in Figure 6, by H. A. Magoon, of Minneapolis, makes rather free use of wooden cabinet work, producing a pleasing feature which might be worked out in concrete stone or cement plaster. Figure 7, by R. W. Hammett, used tapestry brick and wooden cabinet work on exposed surfaces, backed up with concrete block. Similarly, the use of concrete art stone with wooden cabinet work is shown in Figure 8, a mantle by A. Oliver Larson of Minneapolis. The remaining two mantles by Lundie and Twitchell of St. Paul and D. A. MacLaren of Minneapolis show effective treatment of simple design combining cement plaster and brick on concrete structure. All of the designs shown carry the entire fireplace on a reinforced concrete floor slab supported in the wall and extending out before the mantle 12 inches to 18 inches to protect the wooden floor against the heat.

✦
A FEW shingles (571 M.) were imported from China to this country in 1920. The rest, 1,962,996 M., came from Canada.

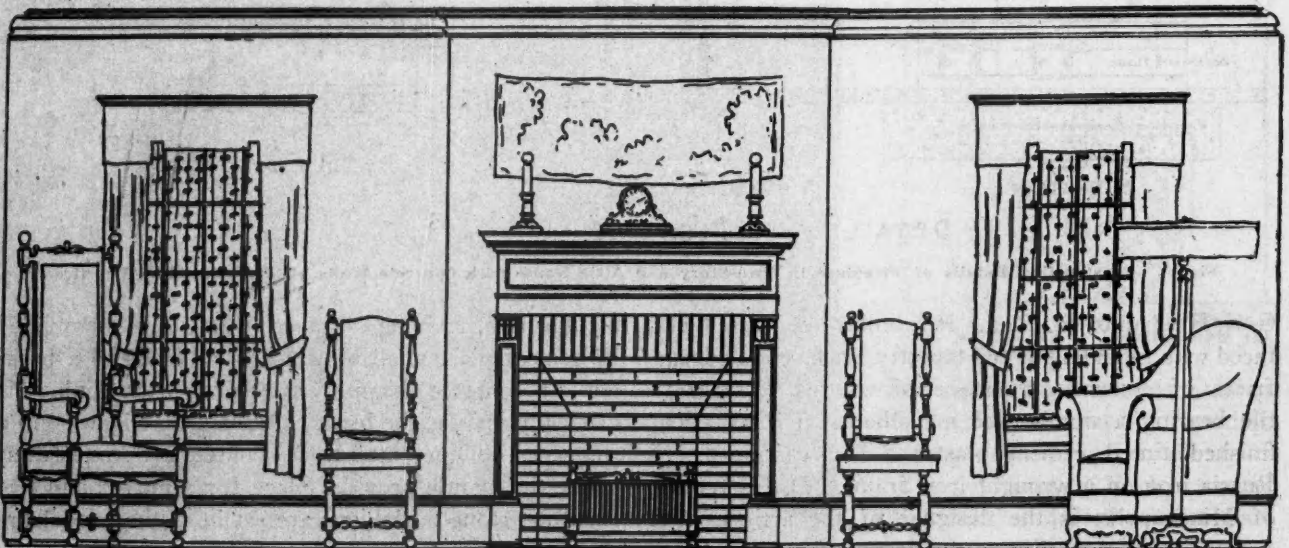

Fig. 7. Pleasing Rendering of Fireplace and Adjoining Details. Tapestry Brick with Concrete Shelf and Frame Has Been Used.



The Variegated Asphalt Shingle Roof, Showing Tapestry or Blended Effect Produced by Using Red, Green or Black Shingles in Combination. This Attractive Color Scheme Does Away with the Flat Monotony of the Ordinary Roof.

New Roofs From Old Rags

FATHER'S SHIRTS AND MOTHER'S DISCARDED DRESSES TRANSFORMED INTO BEAUTIFULLY SHADED SHINGLES. NOW COVERING MANY HOMES

FROM rags to roof is a far cry. But nevertheless old rags are now covering more American houses in the form of roll roofings and prepared shingles than all other types of roofing combined. Two-thirds of all roofing requirements in the United States are now supplied from asphalt materials known as "prepared roofing," the product of a novel and typically American industry that has been developed within the past few years.

Now comes the variegated asphalt roof—the tapestry or blended color effect produced by a combination

of red and green asphalt shingles or a combination of red, green, and black.

The artistic effect of the gray green or sage green shingle, as well as the attractive shades of tile red, brick red, or deep red, have often led architects to specify a green or red asphalt shingle roof. Architects also have felt at times that the flat effect of an asphalt shingle roof is a handicap and that something should be done to relieve a certain dull monotony that militates against securing certain aesthetic values. It was in wrestling

(Continued to page 164.)



Another Striking Example of the Variegated Roof. In Laying This Roof Care Must Be Taken to Avoid a Definite Pattern. The Shingles Are Thoroughly Mixed and the Roofer Simply Lays Different Colors on the Same Course.

METAL CONSTRUCTION

EDITOR'S NOTE: *The American Builder prides itself that it keeps abreast with the latest developments in building methods and materials. Recently some striking changes have been wrought by the introduction of metal materials in varied form. To acquaint our readers with these developments we are inaugurating this new department in which each month will appear an article by some authority on some phase of metal construction. We invite contributions from those who are in a position to give our readers definite and reliable information. Firms and individuals are invited to co-operate.*

Laying Batten Copper Roofing and Flashings

By William Neubecker

GOOD rib or batten type of roofing is recommended especially for copper roofing, as it allows maximum provisions for expansion and contraction. It is highly desirable when an ornamental and architectural effect is required. This style of roof can be laid with various shapes of ribs or battens, such as the architect may specify.

Fig. 1 shows four typical sections of wood battens or ribs to be covered with sheet copper. Full size measurements are given, which can be changed as desired. These battens are nailed or screwed to the roof surface from eave to ridge and should be of cypress.

Care must be taken when nailing the wood ribs on to the roof surface, to make the distance between the arrow points in Fig. 2, $\frac{1}{8}$ inch more than the distance that the sheets are turned up. If the sheets are bent up 19 inches between the sides, then must the distance between the arrow points in Fig. 2, be $19\frac{1}{8}$ inches. When nailing on these wood ribs, a wooden stay should be used as indicated by A, which gives accuracy in spacing.

Fig. 3 shows a typical view of batten copper roofing,

with dimensions between the battens for using 24-inch wide copper sheets by 96 or 120 inches long. When the sheets are bent up in the cornice brake, then their lengths are ordered to suit the length of the brake. If the roofer has no brake, then 120-inch long sheets should be used and the bends made with the roofing tongs. The longer the sheet the less cross seams to be locked. If 24-

inch wide sheets are to be used, then the amount of copper roof surface between the battens will be as follows: Two times $\frac{1}{2}$ -inch lock, plus two times 2-inch sides, equals 5; 24 inches minus 5 equals 19 inches or the copper roof surface. Add $\frac{1}{8}$ inch, thus making the

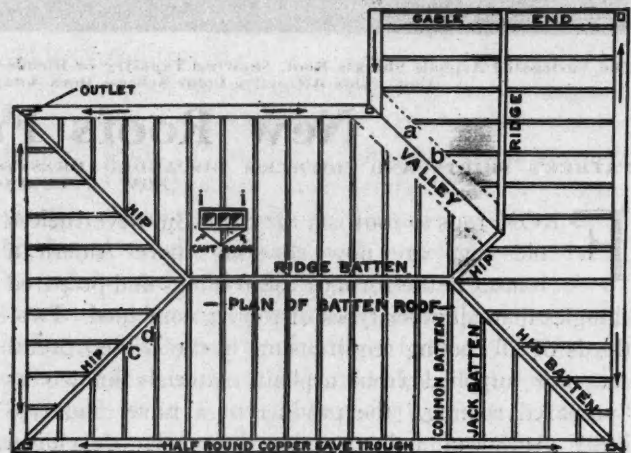

Plan View of Hipped Batten Roof Showing Eave Troughs, Outlets, Hips, Ridges, Gable End and Cant Board Behind Chimney.

distance between the wood ribs $19\frac{1}{8}$ inches as shown in Fig. 2. The construction of batten roofing is similar, regardless of what style batten is employed. For this style of roofing, the pitch should not be less than 15 degrees or 3 inches to the foot.

Determining the Angle of Any Sloping Roof

How the angle of any sloping roof is determined, when the degree of pitch is known, is shown in Fig. 4, with the aid of a protractor. If no protractor is at hand, one can be made on the job by striking any size semi-circle as shown, and dividing the quadrant or quarter circle in division as indicated, when a line drawn from the center A, thru the divisions marked 20, 30 and 45, would represent respectively the roof pitches having 20, 30 and 45 degrees. The same applies to any number of degrees.

Securing the Cleats for Holding Batten Copper Roofing

All copper cleats should be not less than one inch wide and made of 14 oz. soft copper. There are three ways of securing them to the wood battens. Fig. 5 shows the first method. Copper strips of sufficient length are placed under the battens 12 inches apart, before the batten is nailed tight and are then bent up

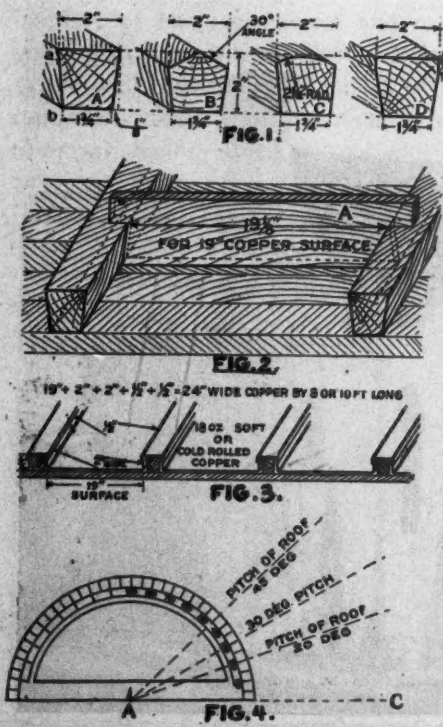
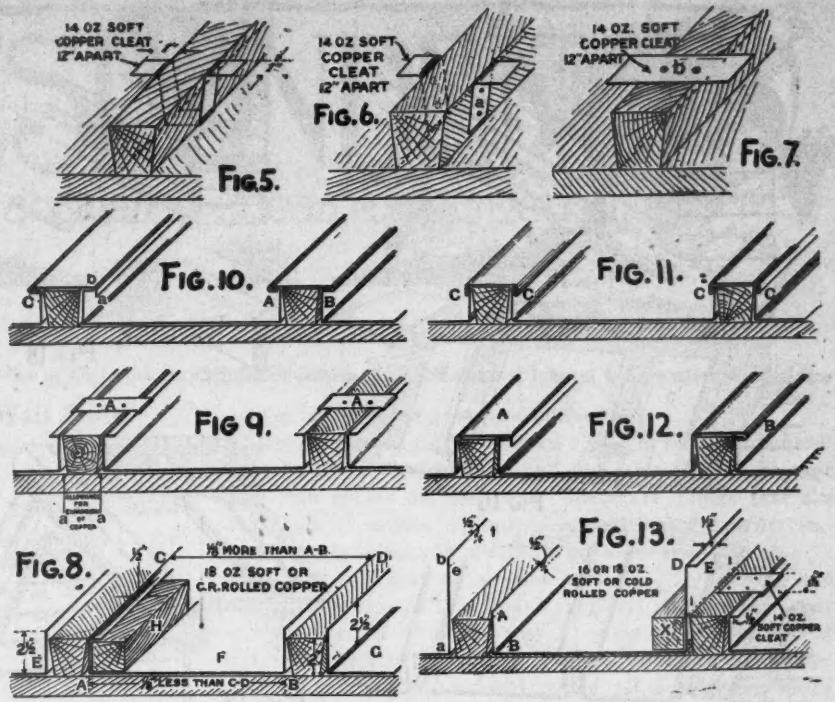

Fig. 1-4. Showing Preliminary Steps in Batten Roofing Job. Fig. 4. Shows a Protractor for Getting Room Pitch.

as shown. Fig. 6 shows the cleat nailed at *a* or to the sides of the tapering batten, while Fig. 7 shows a simple way of nailing direct to the top of the batten, as at *b*. In all cases, use copper nails, $\frac{3}{4}$ inch long.

Method of Bending the Standing Edges on the Copper Sheets

When the roofer has no brake to bend up the sheets, they can be turned up with the roofing tongs direct on the job as shown in Fig. 8. Knowing that the height of the wood batten is 2 inches, then bend up the sides of the sheet $2\frac{1}{2}$ inches as shown at E. Now using a wooden strip, H, of the desired height, or 2 inches, lay it against the bent up side as in F and with the mallet dress over the $\frac{1}{2}$ -inch edge as shown. Do this on all the sheets E, F and G and they will look as shown in Fig. 9. When a cornice brake is at hand all these bends are made on the required number of sheets in the shop, or on a large job a light cornice brake is usually sent to the job, which saves considerable expense in expressage, as the copper sheets can be shipped direct from the mill to the job and bent up there. After the sheets are in position as in Fig. 9, copper cleats are nailed 12 inches apart and locked to the $\frac{1}{2}$ -inch edge on the sheet as shown by A-A. As the sheets are bent up square, this provides for expansion at *a-a* and in addition to the cleats A-A, gives ample provision for expansion and contraction. When the sheets have all been cleated, they are capped as shown in Fig. 10, the cap first being bent with the tongs or on the brake similar to *a-b-c*, after which *a* is turned and locked to the sheet as indicated by A-B, after which the lock is turned down and closed as shown in Fig. 11 by the letters C. The capping can be lapped 2 inches and need not be soldered when the roof is steep. Sometimes the copper roofing is bent as shown by A in Fig. 12, which has the cap combined with the sheet, thus requiring but one double seam as at B. If a brake is at hand, all the copper sheets are bent in the shop or at the job, or if no brake is used, the sheets are formed up with the roofing tongs as shown in Fig. 13. If battens are used 2 inches high by 2 inches wide, then turn up the copper sheet 5 inches from *a* to *b* on the one side and $2\frac{1}{2}$ inches on the other side from A to B. Now bend off the $\frac{1}{2}$ -inch edge along *e, f*, and the sheet will look as indicated by C-D-E. Now turn down the projecting $\frac{1}{2}$ inch at A, the same as shown in Fig. 8. Before turning down *i-D-E*, in Fig. 13, cleat the opposite side, using cleats $1\frac{1}{2}$ inches wide as shown, spaced 12 inches apart. Now using a strip of wood shown by X, having a height equal to the height of the batten, press it down firmly against the side of the copper sheet C-D and



Figs. 5-13. Showing Types of Cleats and Methods of Bending Standing Edges on the Copper Sheets. (Drawings, Courtesy C. H. Hussey & Co.)

turn down *i-D-E*, using a mallet to dress down well along the line of the bend *i-i*, which will bring it in the position indicated by A in Fig. 12, and after the edge is closed will look like B, which is then double seamed as shown by C, in Fig. 11.

Laying Base and Counter Flashings

Where the roofing abuts any wall or chimney, the sheets must be turned up not less than 6 inches as illustrated in Fig. 14 and then counter or cap flashed as indicated by A and B. The roofing sheet X is secured to the roof by copper cleats shown by F, placed 12 inches apart, secured to the roof boards with copper nails and the tail end of the cleat turned over to cover the nail heads. The length of F should be $\frac{1}{2}$ inch longer than the height of the upturned flashing, which allows it to be turned over the flashing as at *i*. The joints between the brick work should be dug out $1\frac{1}{2}$ inches deep, to allow the insertion of the cap flashing along *a-b* and *c-d*. These joints should be made tight by plugging same with lead plugs 1 inch wide, 12 inches apart and fill the balance of the joints with paintskin. The counter flashing may be nailed

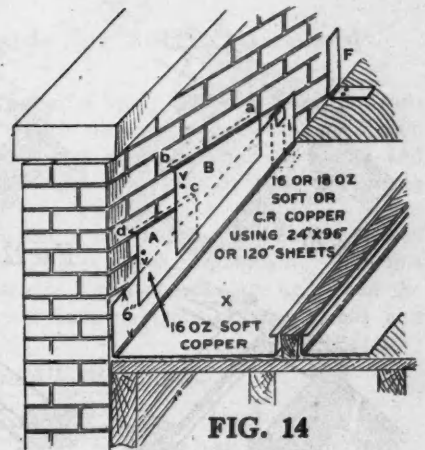
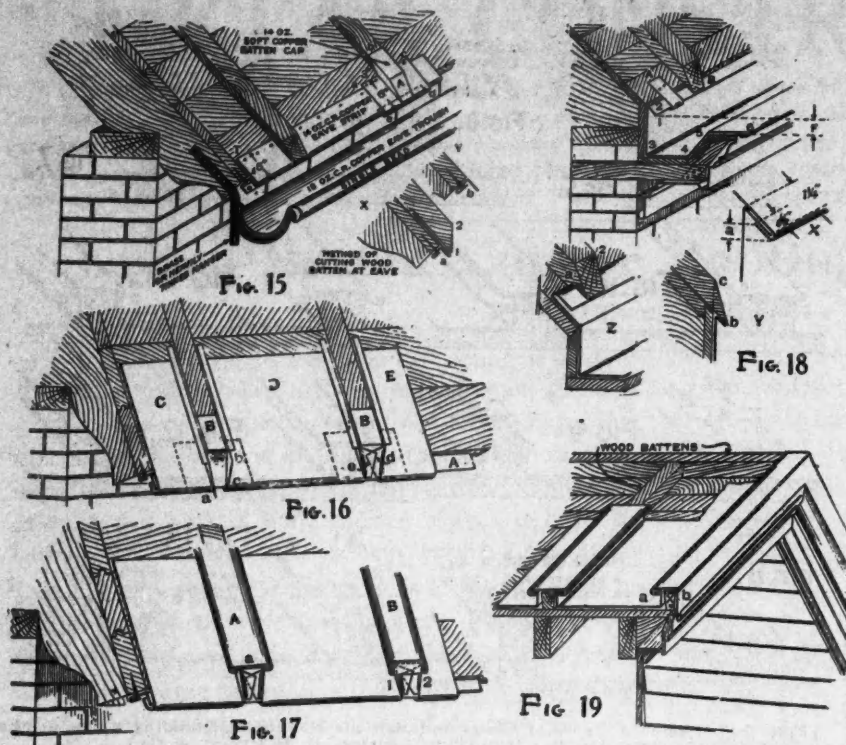

Fig. 14. Showing How to Lay Base and Counter Flashings.



Figs. 15-19. Finishing Batten Copper Roofing at Eaves Connecting with Box Gutters.

with a brass nail at the brick joints as at V and V. If the wall is of stone or terra cotta, a raggle or groove must be cut in same about 1 inch above the upper edge of the base flashing, 1/2 inch wide by 1 1/2 inches deep and a continuous cap flashing secured to same, in precisely the same manner as explained for the counter flashing.

Finishing Batten Copper Roofing at Eaves With Copper Eave

Fig. 15 shows the method of using a copper eave strip in connection with the copper roofing. This strip is formed as indicated at T, nailing it to the eave at O, also on to the roof at T, using 3/4-inch copper nails. The flange on the roof is made 5 inches or can be made less if desired. After the eave strip is nailed on the roof, the wood battens are nailed in their proper position, and the lower end of each batten is

covered with a cap about 6 inches long made of 14-ounce soft copper which must fit snug and tight around the wood batten as shown by a-b-c, flanging out on the roof 3 inches and soldering in the head A at the end, with a lock along the bottom, as well as along the 3-inch flanges, to hook on to the eave strip along e-d. The wood battens at the eave should be cut off vertically as shown in diagram X by 1-2.

The head A should be well soldered to the batten cap before it is slipped over the wood batten.

The edge of the eave strip shown by O in the illustration is turned over to cover the nail heads as in diagram X, at a. If desired, in place of an eave strip, an angle strip can be used as shown in diagram Y by b. Some roofers omit the copper batten caps and simply solder a head over the ends of the battens or ribs after the copper roofing is

completed. This is not recommended, as these soldered heads are liable to break by expansion and contraction and cause leaks. After all batten eave caps are in position the copper roofing is laid as shown in Fig. 16 by C-D and E. Note how the lower part of the sheets lock to the eave angle A, allowing the upturned side of sheet C to project as indicated at a. The upturned side is then cut as shown by b-c on the sheet D and after the lower ends of all sheets have been notched in this manner, they are turned down over the ends of the batten as shown by d and e. Even tho rain should drive behind these flanges e and d, there will be no leak as the copper batten caps B and B protect against any leakage. The top caps are now locked to the edges of the sheets as shown by A in Fig. 17, allowing the upper surface of the cap at a to project about 3/4 inch beyond the end of the batten, to allow it to be turned down in B, over the double seams on each side at 1 and 2.

Copper Lined Box Gutters

When box gutters are lined with sheet copper, the batten copper roofing may be connected as shown in Fig. 18. The gutter is lined with sheets of copper as shown by 1-2-3-4-5-6, locking the front edge to the angle of the copper cornice or to an angle nailed to a wood cornice, then turning the lock down with the mallet at 6. An edge is bent to the rear of the gutter at 1-2, 1 1/4 inches wide, as shown in detail in diagram X and this edge secured to the roof surface with the cleat A, made of soft copper 1 inch wide, nailed with two copper nails, allowing sufficient metal at A to cover the nail heads. These cleats are placed 12 inches apart with the hooking edge not more than 1/2 inch. When the roofing is locked over this gutter edge, the

(Continued to page 166.)

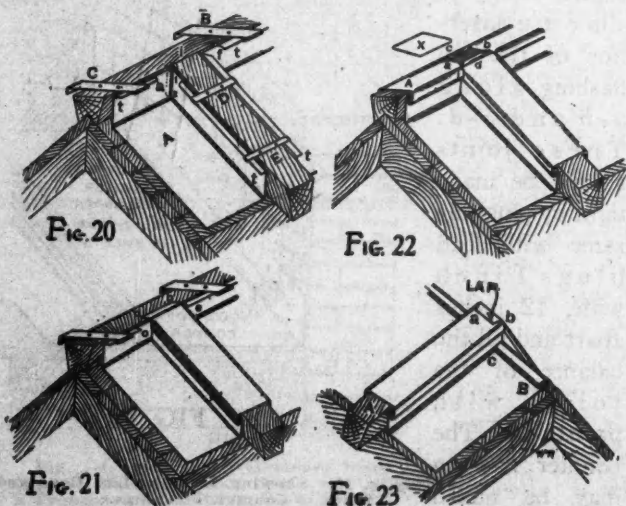

Figs. 20-23. Finishing Batten Copper Roofing at the Ridge.

CORRESPONDENCE

Questions answered—ideas exchanged

Our Readers are Requested and Urged to Make Free Use of These Columns for the Discussion of all Questions of Interest to Carpenters and Builders

Believes "Bungalowette" Will Help Building Shortage

To the Editor:

Represa, Calif.

On page 90 of the February AMERICAN BUILDER is introduced the feature that is certain to aid in the solution of the present building shortage, i.e., the "Bungalowette."

Naturally, I find something about the design to criticise, and have made a sketch of a change in the floor plan and size that would produce a better structure and one that would continue to be of service at a very low cost long after the "big house" was built.

The general idea of the floor plan follows one that was used in the construction of some 300 permanent dwellings for employes in an oil field town in the Southwest.

Comparing the features of the two plans, I find these points to be of the greatest importance. In the design printed in the magazine there is but one bedroom—and it is frequent that more are wanted. This one has the disadvantage of being also the room of entrance from the street, and that means that if there is any sickness there is no privacy and quiet to the sick room as there should be. The dining room is too small to be of real service as a temporary bedroom, while the dining table still remained in it, and is the room of passage from the front door to the kitchen.

In the design I am submitting, there is a bedroom that has no other use. It is small, but still provides comfortable quarters, and with the built-in section, allows considerable free space as well as sufficient ventilation thru the two windows.

The bath is so located that it has equal access from both of the bedrooms that might be used. The use of a bed closet

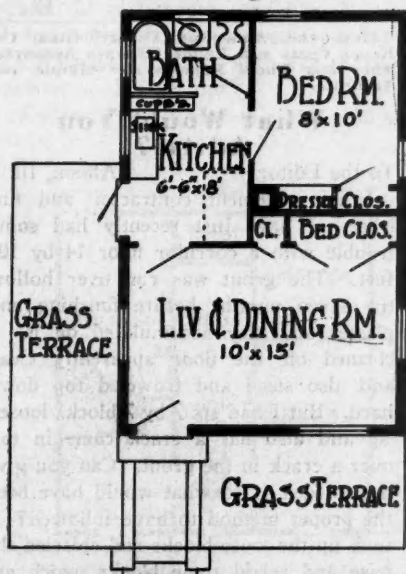

Suggested Revision of "Bungalowette" Floor Plan Published in February. Mr. Adams Reports That This Cozy Little Home Can Be Built for \$300-\$350.

in the living-dining room, placed behind glazed doors takes from that room any suggestion that it is to do service as a bedroom on emergency. In the small house it is more desirable to have a large combined living-dining room than to have two small ones, and hence this arrangement.

The porch is omitted in favor of a grass terrace connected with the street by a concrete walk and steps at the terrace edge. The porch idea could be as easily provided, and a

small screened porch from the kitchen exit.

If desired a small closet could be placed in the bedroom that would be under the chimney, and thus supply more storage space than shows on the plan. These are things that are worked out to satisfy the individual and that are rather impossible to satisfactorily establish on a general plan.

And now for another valuable feature. By moving the door one foot toward the window, and constructing the front section so that it would be easy of removal to a height of eight feet, the inner partitions (which would be of plaster board or similar construction), could all be removed with the possible exception of the one surrounding the bath. This would make the structure continue in service as a garage, and with a very low cost for the re-design to suit the new purpose.

That, of course, leads us into another idea. The lot plan should be fully worked out before the "Bungalowette" is built, and the small building put in the location that the garage is to occupy. This would make the temporary dwelling a little farther from the street than is usual, but economy is the reason for the use of this type, and that would be a very minor discomfort.

No elevation has been presented to fit this floor plan. The architectural treatment of this structure should resemble the type that is desired for the permanent dwelling, in this way there would be a more artistic setting for the home than where two distinct types are followed.

As to cost—built here on the coast this house would fall well under \$800.00; but when built in a country where the walls must be so constructed as to provide protection against cold and severe storm, and the roof to support a snow load, the cost would approximate \$950.00.

I hope that this will be of use to you in presenting this valuable feature to the builders and prospective home owners of the country, as it looks like a sensible solution of the housing shortage.

JAMES E. ADAMS.



Sends Guide for Setting Ground

To the Editor:

I am sending a sketch of a handy guide for setting grounds in floor openings. Plumb the ground guide and tack with one nail at each end; then slip laths into place, nail and take off ground guide and you have an even and plumb ground.

The old way of nailing a lath flat on the side of the wall next to the doorway is never plumb nor straight. With this little device everything is plumb and straight and when the plastering is done you have no trouble fitting jambs and casings.

R. A. MILLIN.

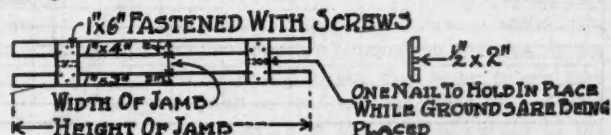

Sketch of Handy Guide for Setting Grounds Submitted by Bro. R. A. Millin.

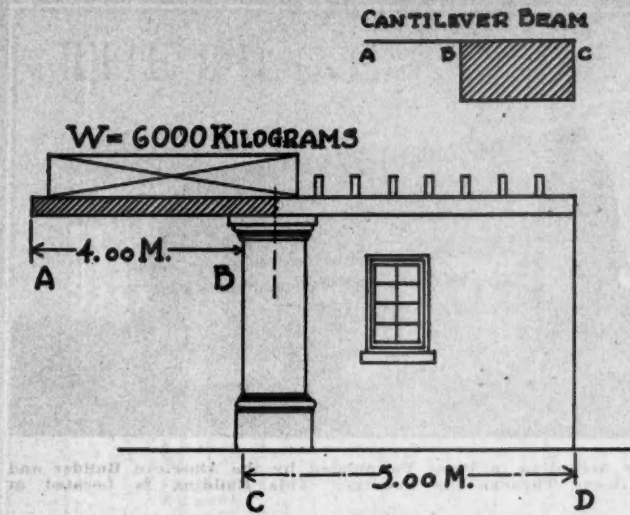

Sketch of Cantilever Beam Problem Submitted by Bro. Segura of Mexico. He Would Like to Get the Solution in The Metric System. Go to It, Boys.

Cantilever Beam Problem

2 a Sta. Teresa,
Mexico, D. F.

To the Editor:

I am enclosing a sketch of a problem which I would like to have solved. It has to do with the construction of a cantilever beam as shown in the diagram.

AC is the cantilever to be built 4 meters long supporting a load of 6,000 kilos. (For the benefit of those who are not acquainted with the metric system, a meter is 39.37 inches and a kilogram is 2.2 lbs.—Editor.)

CD is 5 meters long with a total weight of 7,300 kilos.

What size beam will I need for the cantilever, what size reinforcing rods must I use and what size stirrups? I would also like to have someone explain the formula for arriving at these results.

Your magazine is anxiously awaited here each month.
JOAQUIN SEGURA, C. E.



Rafter Span Troubles Him

To the Editor:

Wickliffe, Ohio.

Always interested in your many helpful talks, I am sending you a pencil sketch of a building I am called upon to build. It is 42 feet square and the roof problem is troubling me, as the rafter span would be 21, making a run probably 24 feet which is longer than most stock lumber. Will you please advise as to the best way to frame the roof and still finish to look attractive?

Do you think it wise to use 2 x 10 second floor joist?

R. L. MOYER.

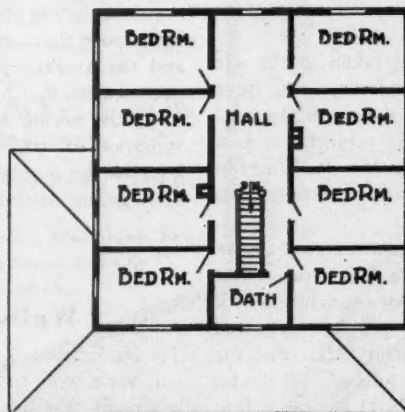
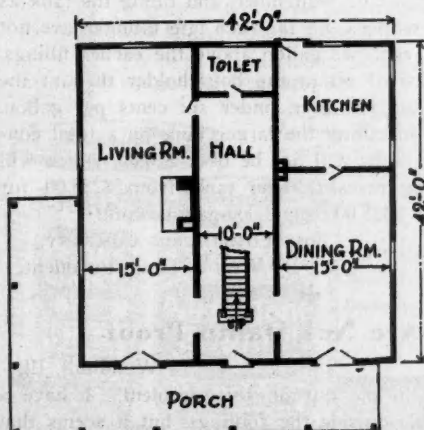

Floor Plans of Building That Has Long Roof Span. The Structure Is 42 Feet Square. Giving a Rafter Span of 21 Feet.

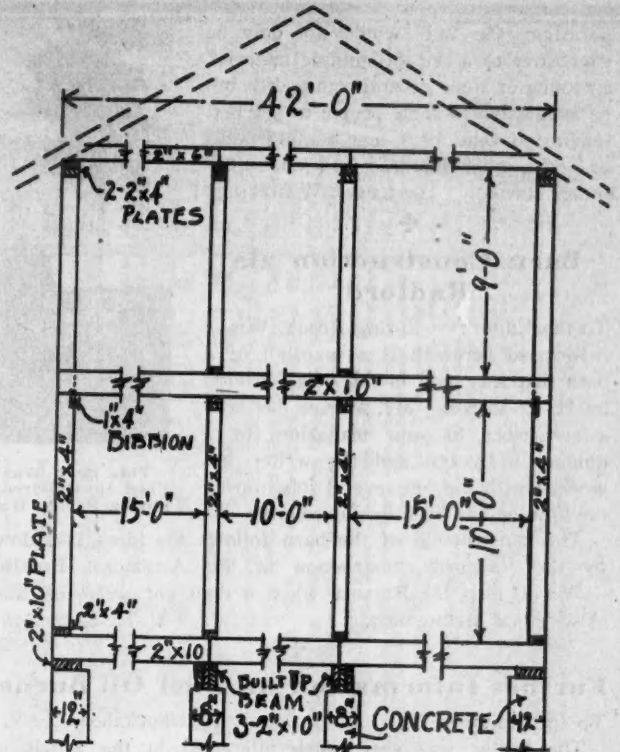

Cross Section of House Showing Concrete Foundation, Floor Joists, and Studding. Bro. Moyer Wants to Get Advice on Framing the Roof.

Is This Truss O.K.?

To the Editor:

Garden City, Iowa.

I have been reading your correspondence department and find it a great help in all lines.

I am sending a sketch of a truss which I want to submit to readers of this department. I intend to use this for a

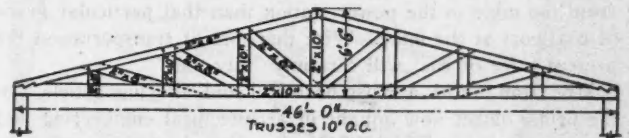

Truss Problems Seem to Bother Readers More than Any Other. Here Is Another One Submitted by F. V. Beran, Who Is Going to Build a Garage 46 Feet Wide, Trusses Set 10 Feet Apart.

roof on a garage. There will be a space about 40 feet and I do not want any posts in the place. The garage will be 40 or 46 feet wide and the trusses will be 10 feet apart.

Will you give me your opinion as to whether the truss I have sketched will be satisfactory for that width of roof, or send me details of the strongest and most economical way to build it and make it a safe roof?

F. V. BERAN.



Here is a Practical Suggestion

Washington County, Box 212,

To the Editor: Eastport, Me.

Would you kindly furnish the address of some one dealing in building material, paints, roofings, etc., who puts out a thermometer as an advertisement? I receive the U. S. Dept of Agriculture weather reports and have a metal case thermometer hanging on the side of my house and notice that some people take pains to read weather forecasts and note temperatures daily. It occurred to me that if I could procure some trade thermometer for cost of packing and trans-

portation, the "ad" would not only be suggestive of a certain building material, a roofing or some general commodity, but be suggestive to some people to get that repair job done, have new roofing done, or some other hundred and one other things started. ARTHUR J. WAHLEN.



Barn Construction ala Radford

To the Editor: Spring Brook, Wis.

Inclosed herewith is a snapshot of a barn that was built in this neighborhood by H. C. McKee. Mr. McKee has been a subscriber to your magazine for a number of years, and the writer has worked with him on several jobs during the time he has lived in this country.

The construction of the barn follows the ideas laid down by the Radford construction in the AMERICAN BUILDER.

We all miss the BUILDER when it does not arrive on time. Also FARM MECHANICS. H. K. EDGERTON.



Further Information on Fuel Oil Burner

To the Editor: Tuckahoe, N. Y.

The writer was very much interested in the article on "Fuel Oil Burning" by Wm. T. Dean, March issue of AMERICAN BUILDER, as we have figured many times on his subject.

The "lofty cost" of coal is probably "with us" for a "long while to come," therefore fuel oil burning ought to have a good chance to demonstrate its superiority, providing the operating expense can be kept equal to or slightly below that of coal.

In figuring the operating cost of a power plant lately, we found it cost 30 per cent per ton more to transport the coal from the mine to the power station than that particular grade of coal cost at the mine. With this sort of transportation the present price of coal will certainly "stay put."

Mr. Dean wrote a most beautiful and alluring article, but the prime object now sought in architectural engineering and home operation is ECONOMY, therefore the writer, and I am sure many others, would be greatly interested in the publication of a complete comparative tabulated cost of home heating with coal and fuel oil.

Another very interesting part of the subject would be the amount of storage space required, as it must be remembered that in well regulated homes the coal for a full season is stored at one time, it being a haphazard proposition to depend upon the haulage of fuel in bad winter weather.

P. EMERSON WADDELL.

EDITOR'S NOTE: Mr. Waddell's letter was referred to Mr. Dean, whose reply is given herewith:

I am very glad to note the wide interest taken in the use of liquid fuel, as evidenced by numerous letters you have received from your subscribers, following the publication of the short article I prepared for you on this subject. It is a very live question, and the points raised by Mr. P. Emerson Waddell of Tuckahoe, N. Y., are similar to the questions that are asked us daily.

The best answer I can give you on the relative cost as far as residence heating is concerned is to state a few cases that come within my personal knowledge. My own residence, which has twelve rooms, with sun and sleeping porches, required Buckwheat coal costing \$250.50 for the season 1921. For the season just closing not a pound of coal was burned. The total oil cost was \$149.00. In addition I spent \$35.00 for pilot light gas and electric power.

Mr. John Hornung of Glencoe, Ill., who is a well-known

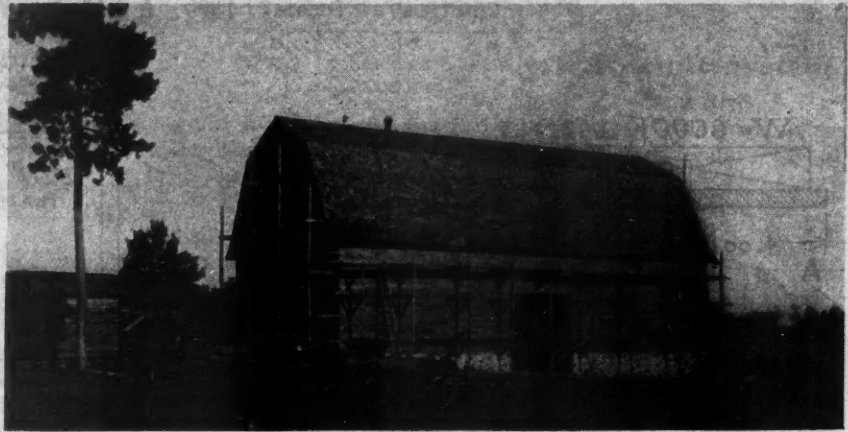

This Barn Was Built According to Plans Formulated by the American Builder and Used in Hundreds of Barns Thruout the Country. This Building Is Located at Spring Brook, Wis.

consulting engineer on heating work, advises that his equipment, started February 1, required just half the dollars to heat with oil in February than were required to purchase coal for heating in January, and the local weather bureau reports show an average mean temperature of the two months within two degrees.

A garage in Chicago with a No. 5 Kewanee boiler spent \$263.99 for coal and \$54.00 for ash removal for the period ending January 31, 1921. Oil was installed during the summer, and for the period ending January 31, 1922, the total oil cost was \$250.30. This comparison was on the basis of Illinois bituminous coal.

A very large apartment building in Chicago advises, without detail figures, a saving of 20 per cent this year over operating cost of coal last year.

I am tabulating data of this character as rapidly as it is received, and will send it to you for publication when it is complete.

The reason for the continued low price of oil as compared with coal is its great overproduction as compared with gasoline and the light derivatives from crude oil, coupled with the circumstance that it is handled mechanically without loss or labor.

The storage space required for oil is one-half that required for coal, as a cubic foot of space will hold twice as many heat units in the form of oil, as it will hold in the form of coal.

It is the practice to install tanks of from 1,000 to 3,000 gallons capacity for storing oil for household use. Such tanks are of steel and are buried below the ground outdoors, so that there is no loss of useful space. For a moderate sized home, not exceeding ten rooms, a 2,000-gallon tank will supply the entire season's fuel. However, in most communities a 1,000-gallon tank is used, the owner purchasing 1,000 gallons at a low price in August or September, and filling the tank as required during the winter. So far such late fillings have not been more than one cent per gallon above the earlier fillings, and the average price of oil to the householder thruout the past season in Chicago has been under six cents per gallon. Thus the saving by installing the larger tank on a total consumption of 2,000 gallons, will not be over \$10.00, which will not justify increasing investment in tank from \$225.00 for 1,000-gallon tank to \$425.00 for 2,000-gallon tank.

THE COMBUSTION COMPANY,
By Wm. T. Dean, President.



Walls Are Not Damp Proof

To the Editor: Woodhull, Ill.

I want you to help me out on this problem. I have a basement that has tile outside the footings, but it seems that the water backs up and soaks thru the cellar wall. Is there any way to waterproof the wall?
TOM WHITE.

THE DRAKE

Chicago's New Hotel



**Johnson's
Perfectone Under-Coat Used**

The Rising Decorating Co., is one of the largest and most successful operators in Chicago. They have built up their business by employing the best mechanics—using the best materials, and giving their customers the finest kind of service. Mr. Rising used **Johnson's Perfectone Under-Coat** for finishing the interior of the beautiful new Drake Hotel at Chicago—one of the finest in the country. **Johnson's Perfectone Under-Coat** was used only after exhaustive experiments and in comparison with numerous brands.

**JOHNSON'S PERFECTONE
UNDER-COAT and ENAMEL**

JOHNSON'S PERFECTONE UNDER-COAT is the perfect foundation for an enamel job—it is elastic, durable, non-porous, has great covering power, works freely under the brush and dries hard in 18 to 24 hours. It will not run, sag, lap, chip, check, crack or peel. Has wonderful smoothness and opacity and will not absorb the enamel.

JOHNSON'S PERFECTONE ENAMEL is very elastic. It will not fade, chip, check, crack or peel. It may be flowed on or brushed out. Made in Satine and High Gloss in white and standard tints.

Prove these statements at our expense—use attached coupon for free samples.

S. C. JOHNSON & SON
"The Wood Finishing Authorities"

RACINE, WIS., U. S. A.

West Drayton, Middlesex, Eng.
Brantford, Ont., Canada
Sydney, Australia.

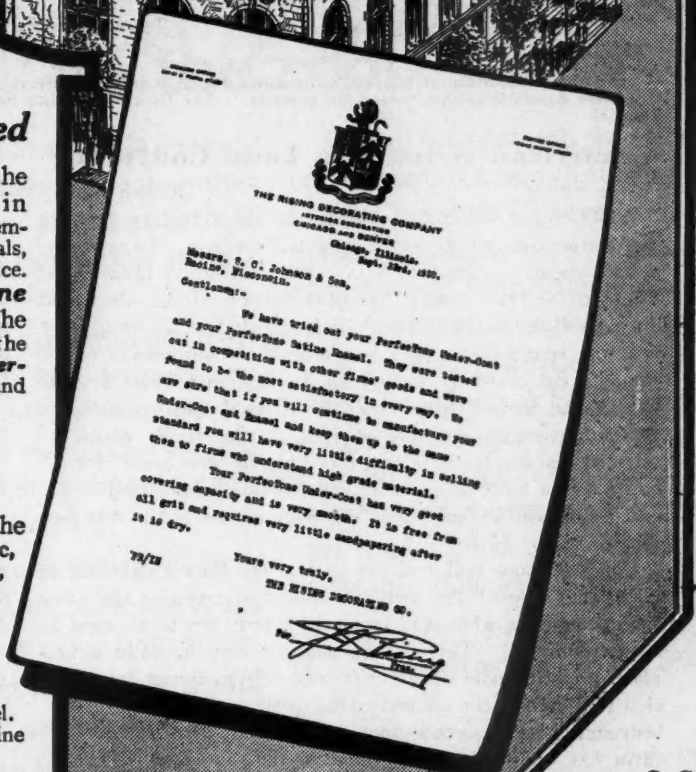

THE RISING DECORATING COMPANY
General Contractors
Chicago and Denver
Chicago, Illinois
Sept. 26th, 1927.

Messrs. S. C. Johnson & Son,
Racine, Wisconsin.

Gentlemen:-

We have tried out your Perfectone Under-Coat and your Perfectone Satine Enamel. They were tested out in competition with other firms' goods and were found to be the most satisfactory in every way. We are sure that if you will continue to manufacture your Under-Coat and Enamel and keep them up to the same standard you will have very little difficulty in selling them to firms who understand high grade material.

Your Perfectone Under-Coat has very good covering capacity and is very smooth. It is free from all grit and requires very little sandpapering after it is dry.

Yours very truly,
THE RISING DECORATING CO.

7/12

S. C. JOHNSON & SON, DEPT. AB-5
RACINE, WISCONSIN

Please send me pint samples of JOHNSON'S PERFECTONE UNDER-COAT and ENAMEL free and postpaid.

Shade preferred.....
The best dealer to carry your line in this locality is.....

Name.....

Address.....

City and State.....

(Please enclose your business card or letter head)

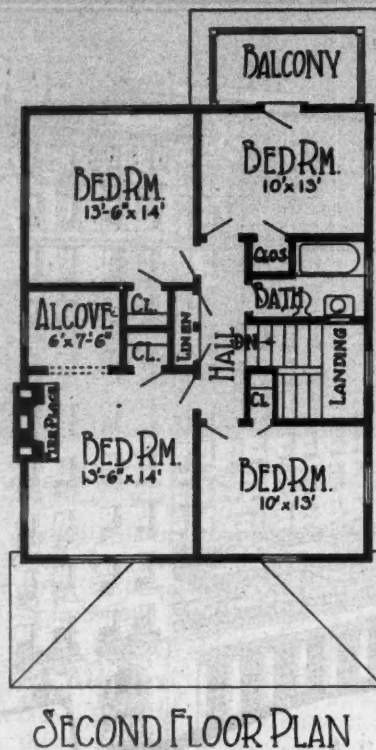
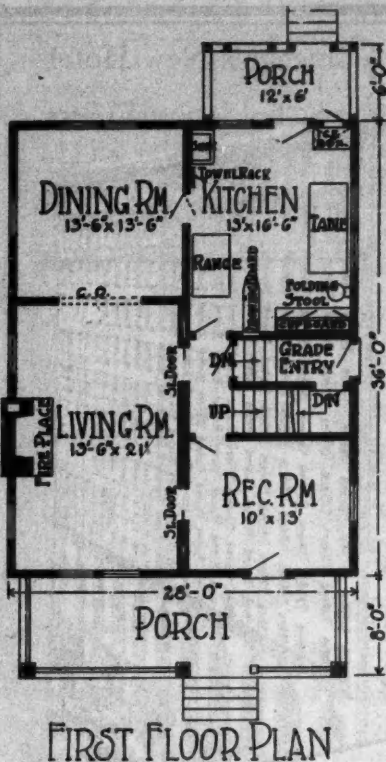

Revised Floor Plan of Blue Ribbon Home Which Landed Contract for J. H. Mongeau. His Sales Agent Was the "American Builder." For Original Design See November Issue. Page 45.

American Helps Him Land Contract

To the Editor: Quebec, Can.
 While trying to land a contract in my a locality recently the AMERICAN BUILDER proved to be a great help. As my prospective client happened to be a rather well-to-do farmer and father of a large family, the Blue Ribbon Home illustrated on page 45 of the November issue struck him as being very near the layout that would best meet the requirements of his family. By carefully explaining to him just how the few changes he wished made could be effected and by adding a few other suggestions, we arrived at the result which so satisfied him and his wife that they "placed their order" for the house to be built as soon as construction could start. The new house will be built along the lines shown in the attached sketch.

You will note that the sun parlor has been eliminated to allow that side of the house to face the street, at the same time permitting what was formerly a bedroom to be used as a reception hall. This change made it easy to build a fireplace in the middle of the left wall of the living room and also in a convenient corner of the front bedroom on the second floor. As the farm has need for a large kitchen, the breakfast nook was taken out and the corner reserved for a sink. The stairs were arranged so as to leave room for a passage between the kitchen and the front hall, and the door leading to the cellar was placed in this passage, adding more room to the kitchen. You will also note the added convenience on the second floor by locating all closets near the doors of their respective rooms and allowing plenty of wall space for furniture. A large linen closet has also been added to the second floor hall at the head of the stairs. In short, all the space has been put to good use and, taken as a whole, I think this plan is quite practical for

those wishing a large farm home.

J. H. MONGEAU.

Flat Roof Does Not Drain Quickly

To the Editor: New York, N. Y.
 Last summer I had the porch in front of my residence rebuilt with a flat roof surrounded by a rail.

The carpenter who framed the roof failed to provide enough slope to carry out the water off to the drains, one of which is at each side of the porch adjoining the house proper. An attempt was made to increase the slope by inserting wedges under the roof boards, but this did not accomplish the desired result and in some cases tore holes in the canvas and tarfelt covering.

I would appreciate, indeed, some suggestion as to how this defect may be corrected without having to tear down the entire roof. I suppose it can be done by means of false beams placed over the present roof and another roofing covering put on top, but this may not be entirely satisfactory.

J. R. WEMLINGER.

How Can He Get These Cuts?

Sugarcreek, Ohio.

To the Editor:
 How must a log be cut to obtain the best quarter-sawed grain in white oak? Is the diagram below the proper way?

M. J. MILLER.



Is This the Right Way to Cut a Log to Obtain the Best Quarter-sawed Grain in Oak?

University Student Practical Builder

To the Editor: San Jose, Cal.

The enclosed photo shows one of your Blue Ribbon homes pictured in the January number of the BUILDER. I am a student in Stanford University; thought you might be interested to know that I erected and completed this charming little residence with the assistance of one carpenter during my summer vacation. It was sold as soon as finished. I will build more during the coming year.

BURTON PALMER.



Bungalow Built by University Student, Burton Palmer, Who Makes His College Expenses by Building Homes During His Summer Vacation. This Is a Blue Ribbon Bungalow.



Go "up the roof" faster

Johns-Manville Asbestos Shingles make an altogether quick, clean job that brings you to the ridge pole in jiffy time.

There's no preliminary tearing off, with its dustiness and litter—an unpleasant job for you and the owner both. Just lay the asbestos shingles right over the old roof.

They're surprisingly easy to lay. The nailholes are in them and the nails come with them. Every shingle is straight and true—it's a simple matter to line them up and nail them in place.

Best of all, it's a job that you can be proud of, one that brings in new business. There isn't a better looking or more permanent roofing than Johns-Manville Asbestos Shingles.

Why not handle Johns-Manville Asbestos Shingles in your community? Johns-Manville advertising and dealer's helps are at your service. You can easily build up a steady, profitable business with them.

Write our nearest branch, or to the address below for full particulars.

JOHNS - MANVILLE Inc.
 Madison Avenue at 41st Street, New York City
 Branches in 87 Large Cities
 For Canada:
 Canadian Johns-Manville Co., Ltd., Toronto



COVERS THE CONTINENT

Through—

Asbestos

and its allied products

INSULATION
 that keeps the heat where it belongs

CEMENTS
 that make boiler walls leak-proof

ROOFINGS
 that cut down fire risks

PACKINGS
 that save power waste

LININGS
 that make brakers safe

FIRE PREVENTION PRODUCTS

JOHNS-MANVILLE Asbestos Shingles

Brick Adds Charm to Colonial Design

WHITE TRIM AGAINST RED BACKGROUND PROVIDES HARMONIOUS COLOR SCHEME IN NINE-ROOM HOUSE.

By R. C. Hunter

RED brick walls and white trim give this house a strong color scheme, even the blinds have been finished white. This color scheme goes well with the green lawn, trees and planting.

At the same time the brick walls give a substantial appearance that is so often lacking in frame houses.

The house sits very close to the ground, which increases the broad low effect of the front and tho but recently completed so well does the house fit its surroundings that it appears already aged.

The house measures 40 by 26 feet and provides a total of nine rooms and three baths, two of these rooms and a bath being located on the third floor, no plan of which is shown.

Note the bath rooms; the fixtures are conveniently arranged on opposite walls with the free space in the center. The tubs are recessed and exposed on the front only. Walls and floors are tiled. This gives bath rooms that are the latest word in design.

While this house is larger than the ordinary type it is designed to be comfortable and to accommodate a good-sized family. The bed rooms on the second floor are unusually large and roomy, the master room being 14 by 19 feet 6 inches, easily large enough for secluded study away from the lower floor.

The great living room, 14 by 25 feet, is a feature that adds immensely to the comfort and charm of this quaint modern home. It has the customary large open brick fireplace of the Colonial home.

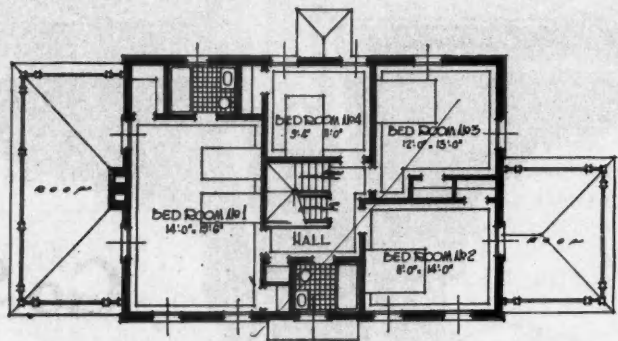
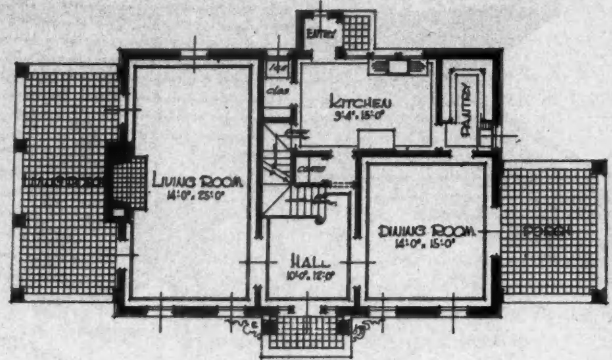

Floor Plans of Red Brick Colonial House, 40 by 26 Feet. There Is Also a Third Floor, Plan Not Shown, with Two Rooms and Bath.

A generous porch is provided at either end of the house, one serving the living room, the other the dining room. The house is designed by R. C. Hunter & Bro. Architects, New York City.

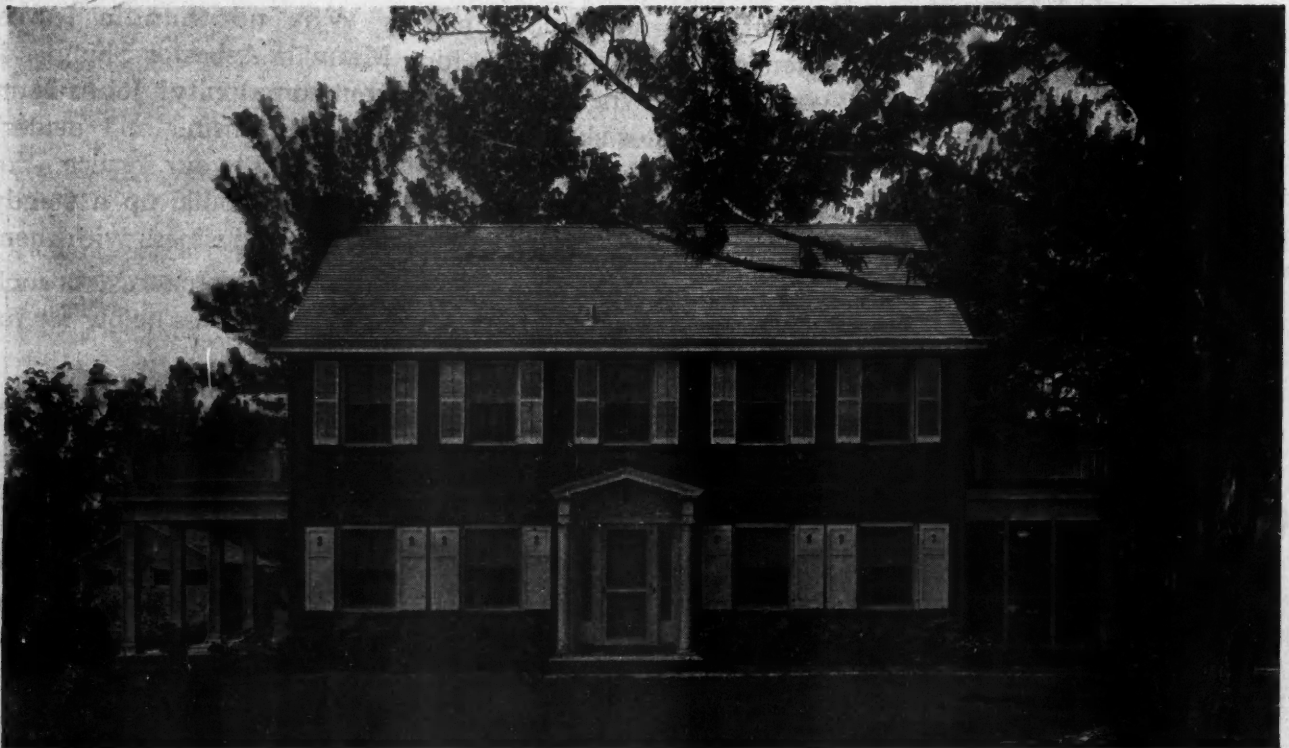

White Against a Red Brick Background Forms a Very Pleasing Contrast in This Well Built Colonial House. It Contains Nine Rooms and Three Baths and is Set Low on the Ground, Giving the Effect of Age, Altho It is Newly Built. There Are Porches on Either End, One a Living, the Other a Sleeping Porch.

Ideal Wall Construction In Over 100 Communities

Although Ideal wall construction has been promoted only during the past year, it has been adopted in over 100 communities. Builders in general have been quick to appreciate its merits. It's fast becoming the prevailing construction for residences.

It has been approved by building experts, architects and engineers. More than 100 cities have adopted it; codes have been amended to permit it. It offers you opportunities possessed by no other form of home building.

Home buyers are attracted by the inviting and pleasing appearance of the Ideal wall homes. Such homes are thoroughly dry, well ventilated and fire-safe. The Ideal wall is the strongest hollow wall ever conceived—there are 2 1/4 inches of solid material at its thinnest point. A strong, durable, sanitary construction for residences, two-family houses, apartments, or garages.

These Books Will Help You Land Jobs



"BRICK—How to Build and Estimate" is the third edition of this practical building manual. It is practically all new material. This book is packed full of good, useful building information. Describes fully Ideal wall construction. Estimating tables, detail drawings, tests of material. Covers brickwork thoroughly. 25 cents prepaid.

Another book you should have is "BRICK for the Average Man's Home." This contains 35 small brick house designs. You can secure working drawings for all of these designs at small cost. \$1.00 postpaid.

The very nominal price of these books is made to cover cost of printing and distribution only. Every builder should have them. They are the most practical books on brickwork ever written. Send \$1.25 to the Common Brick Industry of America, 1306 Schofield Building, Cleveland, and get both books.

"I Have Tried it Out!"

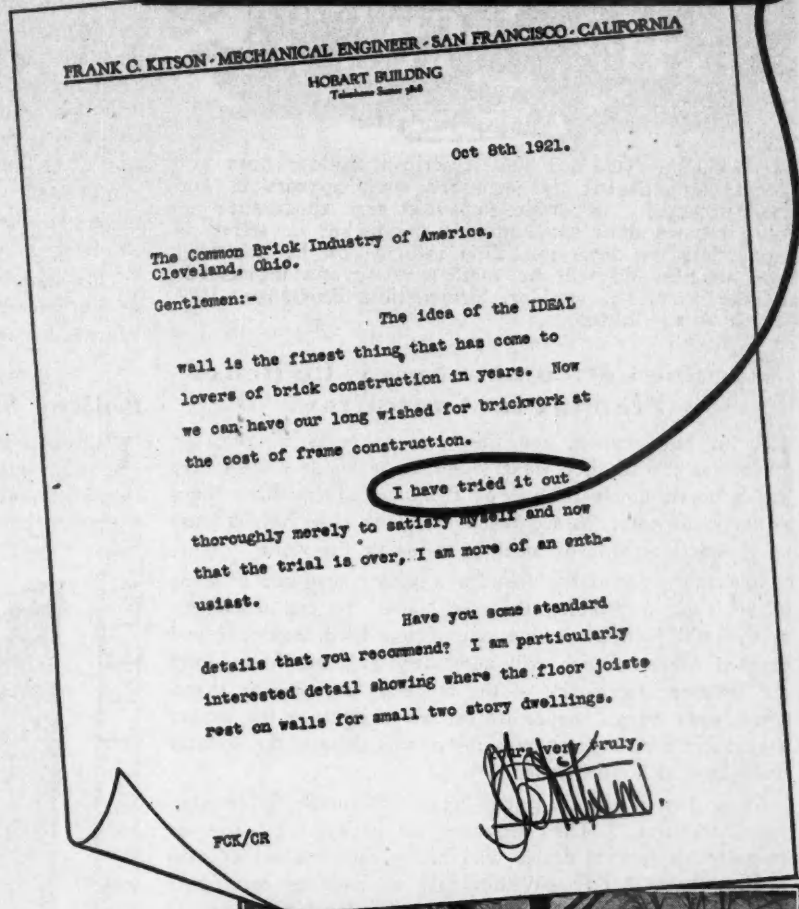

This Trade-Mark Stands for—

- Quality—**
An honest product, honestly advertised.
- Responsibility—**
A reputation for honorable, prompt and efficient business dealings.
- Service—**
A material of proven integrity with a record of ages of service.



The Ideal All-Rolok Wall is laid in the attractive Flemish bond and is just as good looking as it is substantial.

The Common Brick Industry of America
 1306 SCHOFIELD BUILDING
 Cleveland, Ohio

The Ideal wall is made of standard brick obtainable everywhere

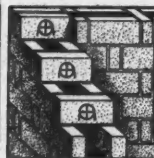

Ideal Brick Hollow Wall
 "Brick Homes at the Cost of Frame"



EDITOR'S NOTE: The American Builder does not accept payment in any form for what appears in our reading pages. In order to avoid any appearance of doing so, we omit the name of the maker or seller of any article we describe. This information is, however, kept on file and will be mailed to anyone interested; address American Builder Information Exchange, 1827 Prairie Ave., Chicago.

Machine Cut Lumber Speeds Up House Framing for Contractor

IN the busy season, and this year promises to give the contractors all they want to do, most builders wish they had a dozen hands instead of two, and about three times as many carpenters as are available. They often have to pass up contracts because of inability to handle the work.

Mechanical genius has found a way to relieve him of some of his work in framing the new house. Special machinery at the mill is now turning out standardized, morticed and tenoned lumber which will accurately fit together to form the skeleton framework of the home of any size or shape. These standardized shapes are carried in stock by the lumber dealer and are made at over forty mills thruout the country under special license rights.

In contrast to the ready cut house, this lumber is distributed by the dealer. The contractor has plans for a house—he consults his lumber dealer who has a complete set of estimating sheets handy. Within half an hour he can figure out his bill of material and send his order to the mill to be cut.

This lumber is then cut in the mill. That is, the sills, plates, studding, ceiling joists, rafters, ridge boards, etc., all the framing is accurately cut to standardized lengths, then dadoed dovetailed shape and tenoned according to their position in the framework. For instance, the studding is tenoned and the plates and sills are dadoed so that the tenon of the

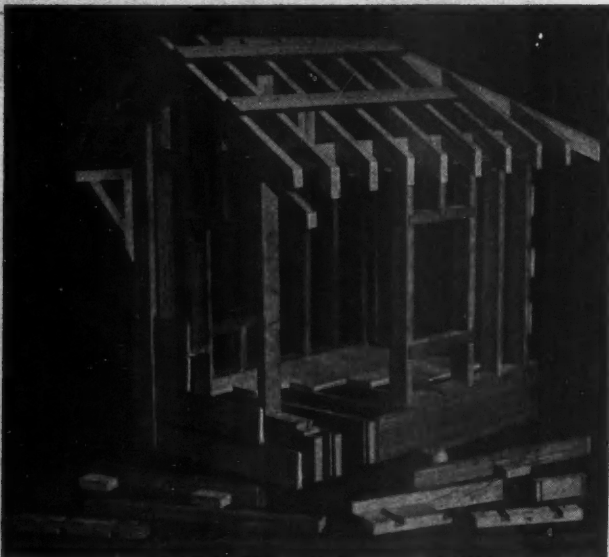

Framework of House in Miniature Showing How Machine Cut Timber is Cut to Fit.

studding will dovetail accurately and firmly into the dado of the sill as shown in the photograph. The sills, plates, etc., are dadoed either 16 or 24-inch on centers, depending on the plans, the flooring ceil sheathing are accurately cut to multiple lengths to fit these spacings.

These pieces of material are ready to use when laid down on the job. For instance, the sill placed just above the foundation is dadoed to receive the tenons of the floor joists. Then a plate is placed above this, generally a 2 by 4, which is dadoed on the upper side to hold the tenons of the studding which rise vertically. They are also tenoned on the other end to fit into the dadoed second floor plate and so on up to the roof. In some cases a strong ridge board is dadoed to received the tenoned ends of the rafters, altho this is not absolutely necessary.

This material is carried as regular yard stock and is more or less interchangeable, resulting in a considerable saving in labor and time on the job.

Rolling Screen Permanent Part of House

TO the average homeowner the coming of spring has one disadvantage, of course, outside of the regular house cleaning; that is the installing of screens. Each year this

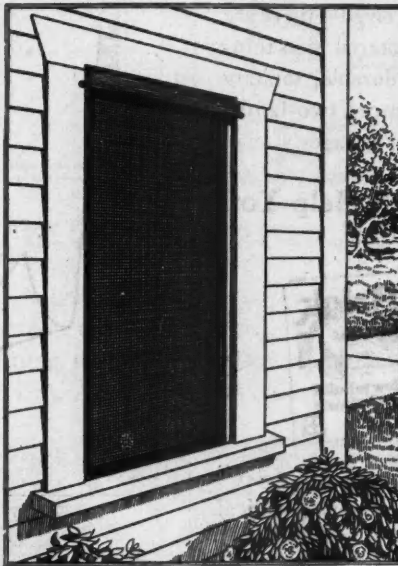

Permanent Rolling Screen—Pulled Down in Summer Like an Ordinary Shade.

is just as inevitable as the planting of the garden. Each year he either worries himself into a frazzled state trying to fit the right ones, or pays some good money to have them installed.

This trouble is eliminated by permanently installed rolling screens which are now available. This roller screen is installed in the upper casing of the window and operated like an ordinary window shade. In the late fall this screen is rolled up out of the way into

a stormproof case; the following spring it is pulled down into place. The spring casing which holds this screen also serves another purpose. It serves to make a storm and water-proof fitting for storm windows when they are used and also serves as a storm strip on the windows at all times.

Paint for Galvanized Iron

THERE are two methods of painting galvanized iron. One way is to wash the surface with acid, prime it with lead and oil, and coat it with ordinary paint. The other method calls for the application of a special paint directly upon the iron without any preliminary preparation.

The process of galvanizing leaves the film of zinc chloride on the metal. No ordinary paint will adhere to this without treatment of the metal. The new paint is so constituted as to neutralize the acid coating on the galvanized iron and form a bond with the metal.

One gallon will cover 550 square feet, and two coats are considered sufficient. It is made in white, black, and six colors.

*Barrett
Everlastic
Roofings*

**Use Roofings
you *know* are Right—**

There's just one kind of roofing that you can afford to use on your roofing jobs—the kind you *know* will give satisfactory service to your customers.

For years Barrett Everlastic Roofings have proved their quality under every condition of service. You can recommend them with confidence.

They are manufactured by The Barrett Company—a firm with more than 60 years successful experience in making quality roofings.

The six styles described below include roofings suitable for any type of steep-roofed building.

Everlastic Octo-Strip Shingles

A new Everlastic Shingle that is the latest development in the strip shingle. Beautiful red or green mineral surface. Made in a form that offers a variety of designs in laying.

Everlastic Multi-Shingles

Four shingles in one. Made of high grade waterproofing materials with a red or green mineral surface. When laid they look exactly like individual shingles.

Everlastic Single Shingles

Same material and art finish (red or green) as the Multi-Shingles, but made in individual shingles; size 8x12½ inches.

Everlastic Giant Shingles

Identical in shape with Everlastic Single Shingles but made considerably heavier and thicker. They are "giants" for strength and durability.

Everlastic Mineral-Surfaced Roofing

The most beautiful and enduring roll roofing made. Surfaced with everlasting mineral in art-shades of red or green. Fire resisting. Nails and cement in each roll.

Everlastic "Rubber" Roofing

One of our most popular roofings. It is tough, pliable, elastic, durable and very low in price. Easy to lay; Nails and cement included in each roll.

The *Barrett* Company



New York	Cincinnati	Minneapolis	Salt Lake City	Milwaukee	Elizabet
Chicago	Pittsburgh	Dallas	Bangor	Toledo	Buffalo
Philadelphia	Detroit	Syracuse	Washington	Columbus	Baltimore
Boston	New Orleans	Peoria	Johnstown	Richmond	Omaha
St. Louis	Birmingham	Atlanta	Lebanon	Latrobe	Houston
Cleveland	Kansas City	Duluth	Youngstown	Bethlehem	Denver
					Jacksonville

THE BARRETT COMPANY, Limited

Montreal	Toronto	Winnipeg	Vancouver	St. John, N. B.	Halifax, N. S.
----------	---------	----------	-----------	-----------------	----------------

Hardwood Veneer Door Has Unique Construction Features

INTERIOR doors are such an important factor in determining real beauty and harmony in the new home that the builder who is not aware of this fact will, more than likely, make a grave mistake by installing doors of inferior quality. He should make it his particular duty to build in to the home only doors that are well-designed and constructed.

One of the most interesting, if not revolutionary, innovations in the manufacture of doors in many years is the introduction of a one-panel door which includes the richness of design of the moulded door. An isometric sketch is shown here. One of the principal features is the substantial veneered construction. This type of construction in a door makes it possible for the hardwood door to show a grain of the hardwood yet have the non-warping qualities of the softwood. The two important parts of a hardwood veneer door, in fact, any veneered door, are the core and the veneer.

In this door the stiles and rails are made up of pine cores with hardwood veneer. The core construction is of special interest. It is made up of pine blocks fitted together by a dove-tailed wedge lock arrangement and grooved to receive the hardwood insert frame of birch, with hardwood moulding

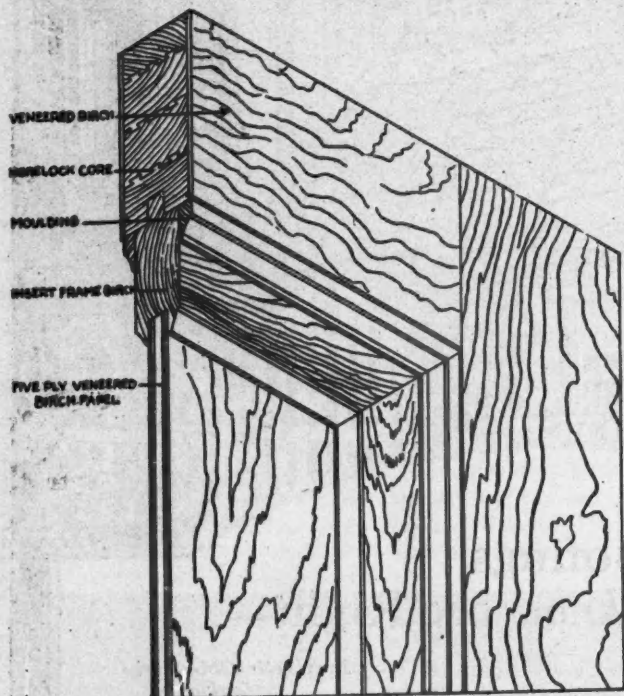

Isometric View of New Hardwood Veneer Door Which Embodies Some Unusual Features. Note the Dove-tailed Core Lock and Five-Ply Panel.

attached. This frame is also grooved to receive a three or five-ply panel, finished with a hardwood veneer.

The rapid recession in thickness from the outside $1\frac{3}{4}$ or $1\frac{1}{2}$ -inch rail by successive stages thru frame and moulding to the $\frac{1}{2}$ -inch panel gives the door a very distinctive appearance. It is finished in any of several hardwood veneers which can be stained in a variety of finishes. Where the door is to open the way into a passageway or room where light is necessary a glass panel is used. The one light design is also desirable for vestibule use. If so desired the door in stock can be promptly changed to a mirror door by applying the mirror mould made for that purpose. This new door is made in the $1\frac{3}{4}$ and $1\frac{1}{2}$ -inch sizes, the lighter size being often suitable in place of the ordinary $1\frac{3}{4}$ -inch door because of the heavy panel recess which suggests a heavier door.

Electric Floor Sander Completes Job

MOST building contractors do not consider their equipment complete unless it includes an electric floor sander which is designed for finishing all grades of both new and old floors. In the case of the new home, the sander removes paint, varnish and dirt that has accumulated during the building work. In the case of old floors it removes the roughness and warps and gives the homeowner a new floor without much delay or expense.



Electric Floor Sander with Capacity for 5,000 Sq. Ft. of Floor Daily.

The handy little floor sander illustrated will surface about 5,000 square feet once over in eight hours. The electric motor can be removed and used for other

purposes when required.

This sander will surface up to within $1\frac{1}{2}$ to 2 inches from the wall. The roller is operated by a silent chain drive and the machine is equipped with an automatic dust collector comparing in action to a vacuum cleaner. This enables the contractor to use it in homes and offices that are occupied.

By adjusting a pressure lever on the handle, the operator can apply any amount of pressure desired for light or heavy cutting. By pulling this lever as far as it will go, the man operating the machine can lift the roller from the floor and adjust new sandpaper on it. The construction thruout is very simple.



Handy Saw Table Can Be Easily Carried

ON many jobs the services of a small saw table are in much demand because it can be carried easily from room to room or from floor to floor. Unless the machine is compact and light, this is difficult to do. To fill this demand a manufacturer has devised a handy sawtable which can be moved easily by two men. It is operated by one-half horsepower or, in the case of light work, one-quarter horsepower. It is equipped with rip and crosscut gauges, saw splitter with guards, one 8-inch saw and internal belt.

The table is 18 by 24 inches, 36 inches high. The net weight is 170 pounds with countershaft.

Supporting the table are tubular steel legs forming a rigid frame. This frame also supports the swinging arm or yoke which carries the saw mandrel.

When fitted for belt drive, the countershaft turns in bab-bitted bearings; when driven from motor the motor is mounted on wood base attached to the swinging arm as shown in Fig. 2. The saw can be raised or lowered and held in position by means of a clamp, a convenient handle being provided for raising and lowering the arm.

A slot is planed in the table for cut-off gauge which is supplied with each machine. This gauge can be set for miter work. The construction of the machine is such that it may be changed from belt to motor drive by removing the pul-

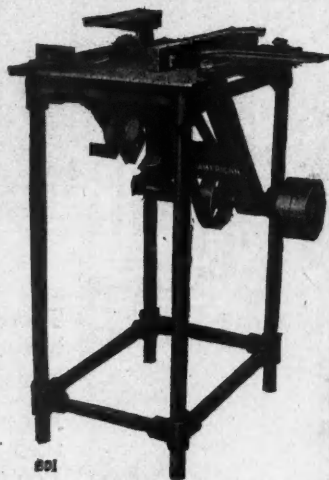

New Handy Saw Table That Can Be Transported Easily from Floor to Floor. It Can Be Used in Many Ways.

Cornell Wood Board



Send for Free
Book of
Interiors

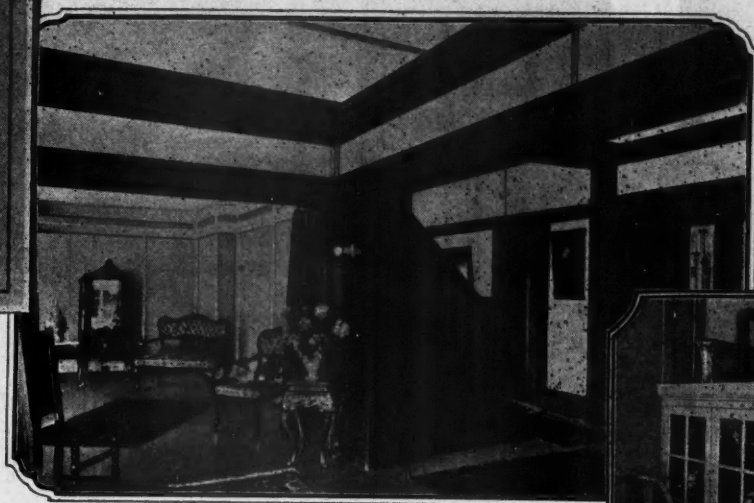

Eight lengths, 6
to 16 feet — two
widths — "Cor-
nell 32" and "Cor-
nell 48"



Rooms Like These At Lowest Cost in Years

CORNELL-Wood-Board panels make the most economical walls, ceilings and partitions you can build.

The cost is lower than lath and plaster or plaster-board. And Cornell lasts longer than ordinary wall-board because it is made of pure wood fiber, "Triple-Sized" with moisture-proof sizing.

When you consider that manufacturers use Cornell for insulating material, you can well imagine that Cornell walls and partitions give exceptional protection against variation in temperatures.

These wide, flat panels are easily applied with hammer and nails to the joists and studding, or over brick or damaged plaster. We guarantee this "Triple-Sized" wood board not to warp or buckle if our simple directions are followed.

Cornell comes all primed for painting—"Mill-Primed". This saves the labor and cost of a priming coat. Its "Oatmeal" finish rivals costly wallpaper, yet costs nothing extra. And it takes a perfect spread of paint or calcimine.

Where speed, economy and cleanliness count, builders cannot find another material to equal it.

FREE Send rough sketch showing room, dimensions and openings and receive special drawings of panel arrangements with estimate. Or write for sample board and Color-Book of Cornell Interiors, **FREE**.

CORNELL WOOD PRODUCTS CO. Dept. AB-3

General Offices, 190 North State Street, Chicago, Illinois

Water Power, Mills and Timberlands in Wisconsin

A new use  every day

leys and mounting the motor, no extra parts except the wood motor base being required.



Service Elevator is Important Equipment in Business Buildings

LITTLE did the builder who installed the first service elevator

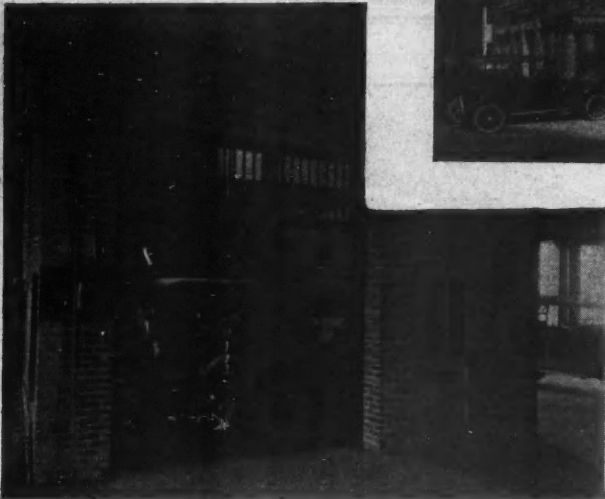

Short Haul Heavy Capacity Freight Elevator in Typical Service Station. This Elevator Has Special Non-Friction Machinery

realize the great service he was rendering nor the valuable precedent he was establishing. Since that time the elevator has lifted untold burdens from the shoulders of the business man and greatly facilitate his handling of business. Due to the elevator top floors are now as accessible as the ground floor.

Elevator design and construction has made great strides in recent years as evidenced by the photograph shown here. The service elevator has come to be an essential feature of all business buildings, especially garages, service stations, and loft buildings. In the picture of the elevator shown here, the machine is used for carrying automobiles from one floor to another.

The mechanical parts are compact and the electrical mechanism effectively protected by special housing. The elevator

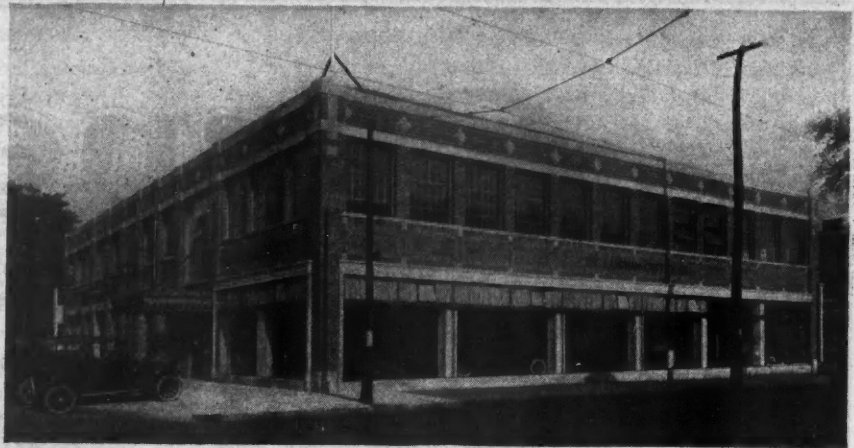

View of Landman-Griffith Automobile Sales Room, Garage and Service Station. There is Constant Need for an Elevator to Convey Heavy Cars from Floor to Floor. Elevator Installation is a Builder's Problem.

operates on a worm drive over a bronze gear. This provides a constant contact which prevents the frequent "jumping" and "bucking" experienced in many elevators. Tremendous pressure or "end thrust," as it is called, is exerted against this worm drive and every precaution must be taken to prevent excessive friction which will result in continual drag and waste of power.

The difficulty has been overcome in the illustrated equipment by the use of roller bearings and bronze gear, running partly immersed in oil. Another important feature of this machine is the absence of electric wiring. The motor is connected to the control mechanism by three short wires which increase safety.



New Steel Fabric for Stucco

BUILDING with stucco is not new. In fact, history does not show record of the earliest practice of this art. We know that it was used extensively in ancient Greece and Egypt, by the Persians, Moors and Italians; even in those days its charms were appreciated.

But the method of application has changed with the ages and principally in the backing, lath or fabric as you will, that is used. One of the recent developments in this material is a fabric made up of either No. 12 or No. 14 gauge cold-drawn galvanized steel wire, which develops a tensile strength of about 60,000 pounds per square inch of steel. This fabric is made in 2 by 2 and 2 by 4 mesh, all wires electrically welded at the intersections.

This wire is crimped at regular intervals, as shown in the illustrations. These crimps make the fabric self-furring and serve to hold it a uniform distance from the background. When the plastic material is applied the wires become thoroly imbedded, resulting in a monolithic construction with great tensile strength. It comes in rolls of 1,000 sq. yds., 48 in. wide.

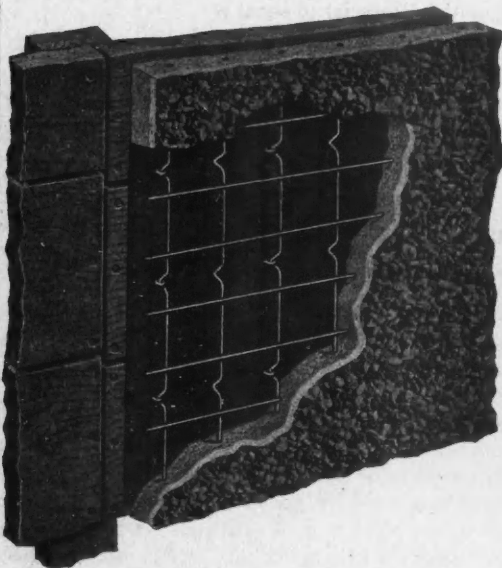

Steel Fabric Backing as It Appears Applied Over Sheathing Boards on New Building. Note the Crimps Which Provide Space for Plaster to Get in Back of Fabric Forming Reinforced Wall

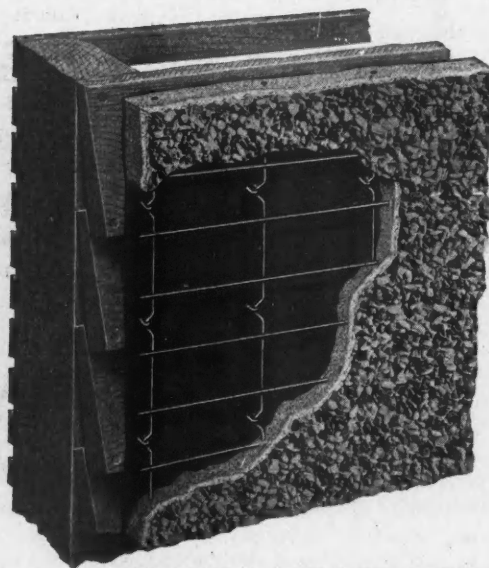

Same Material as It Is Used in Overcoating Job Over Frame Siding. The Siding or Sheathing in Either Case Is First Covered with Felt Paper and Then the Fabric Is Nailed on and Stucco Applied.

HANGER HARDWARE

When It Bears the "Allith-Prouty" Name

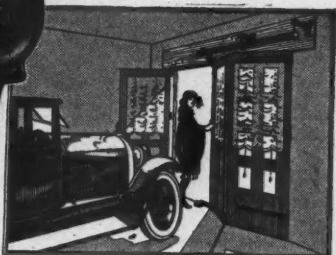
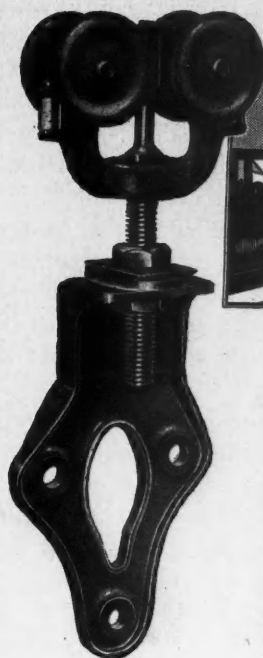

the dealer is giving, and the buyer is getting, all there is to be had in Hanger Hardware. If you have never stocked "Allith-Prouty" you really don't know what a pleasure it is to sell Hanger Hardware that brings every customer and his friends back for other things you handle.

"1080" for Folding, Sliding Garage Doors

Sells quickly; goes up simply; works easily; and stays sold. Hangs three to six doors; makes possible using entire opening or only part of opening; needs but 12" headroom; trolley-swivel, type with vertical side rollers; swivel operates on balls, wheels on rollers; swivels, hangers and brackets unbreakable A-P Malleable. Used with No. 60X high carbon steel rounded wheel trough track. Doors hung with "1080" cannot sag or bind.

"RELIABLE" Hangers and Round Track

One piece, heavily reinforced malleable hangers; double wheel type (upper wheel has machined tread, hardened steel axle, roller bearings; lower wheel prevents all jamming and derailing).

No. 2 Round Track heavy high carbon steel; tube type, slotted for reinforced malleable brackets.

"Reliable" Round Track and No. 2 Hangers have been big business builders for over twenty years.

ALLITH-PROUTY COMPANY
DANVILLE, ILLINOIS

We want you to have our Garage Hanger Hardware Catalog No. 91. Write for it TODAY.



ALLITH-PROUTY
"Satisfaction in Hardware"



Truck Dump Bodies Speed Up Building Job

MANY HOURS ARE SAVED BY AUTOMATIC LOADING FACILITIES ON MOTOR TRUCKS

By R. F. Wood

EDITOR'S NOTE: This is the first article of a series on efficient methods of hauling materials and equipment, emphasizing the importance of special dump bodies.

DURING the period of high material and labor costs, enterprising highway contractors were able to demonstrate that it was possible to build better highways at less cost and thereby produced a result which seemed to be contrary to the prevailing arithmetic of that time. This accomplishment was made possible by bringing into effect the same principles which have decreased cost in many manufacturing industries, i. e., time saving. If the building industry had not come to an almost total standstill thruout the country during the period of inflation, it is not unlikely that a similar demonstration of modern efficiency would have been made there. In fact, it was not unlikely that there were in the building industry isolated examples of this very thing.

In highway construction time was saved and more accurate and rapid production was accomplished principally by means of motor trucks coupled with most carefully planned loading facilities. The building supply dealer and the building contractor can learn much to their profit and advantage by studying the modern methods now developed in great detail by the highway builders.

Ordinarily any motor truck can maneuver in places where horse-drawn equipment cannot go, but experience is steadily showing that handiness of operation is an exceedingly important factor in the use of motor truck equipment. This is especially true in the building industry where much valuable time and labor can be saved if the motor truck is able to deliver its load at

exactly the right spot on the job regardless of the narrow spaces which usually prevail at big building operations.

The building supply dealer and the building contractor can, of course, control to a great degree the conditions under which their trucks shall be loaded. Any building supply dealer with permanent headquarters or any building contractor preparing for a big job, will find it worth while to make a considerable investment in order to be sure that incoming materials will be quickly handled and placed in hoppers or at platforms which their motor trucks can readily reach and from which the trucks can be loaded in a minimum space of time. It should never be necessary for the driver of the motor truck to leave his seat if the loading facilities are properly planned. There would not be time for him to get down and go to the rear to help put on the load before it would already be deposited on the truck.

At the receiving end of the route, that is, at the building operation itself, it is often impossible to create artificially ideal conditions for placing the load. In fact, as the work proceeds it is necessary to deposit the load in entirely different places. On some large building operations much time has been saved by running the motor trucks directly onto an elevator which would carry the truck and its loads up to the floor desired, where the truck would run off and dump the load, eliminating entirely the necessity for wheelbarrow handling.

In connection with the selection of motor trucks for such operations, the length of the wheelbase becomes a matter of first importance. A long wheelbase truck is frequently handicapped by its inability to get into

narrow places and put down the load at exactly the place desired. Such a truck is never able to run onto an ordinary freight elevator. Length of wheelbase does not determine the carrying capacity of a motor truck.

There are on the market motor trucks of short wheelbase design which are capable of carrying all loads which many building contractors would usually be hauling.

Another important point in connection with the selection of motor truck equipment is the assurance of continuous operation. Delays on a building job are always costly and could be disastrous. Building supply dealers and building contractors who are selecting motor trucks should be sure to satisfy themselves that there is available adequate service facilities.

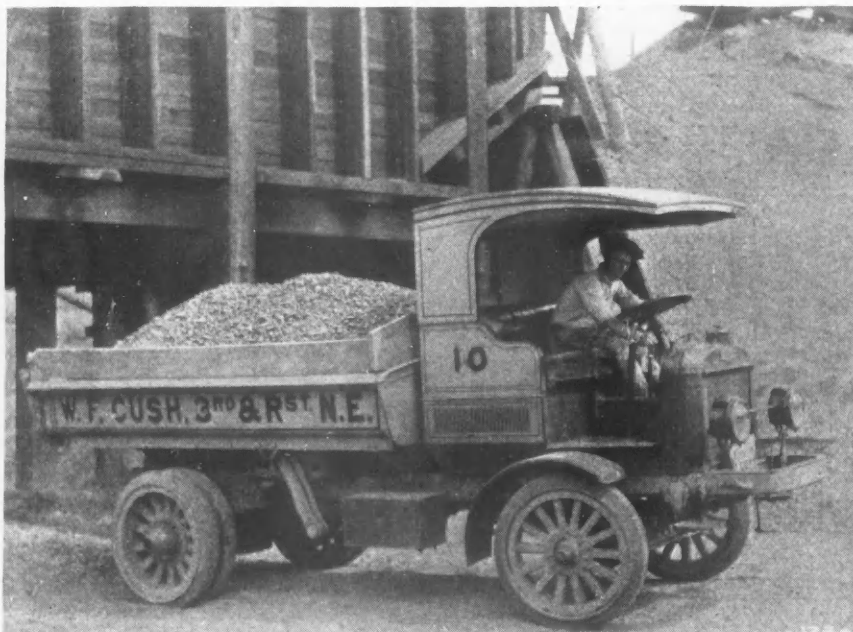

Short Wheel Base Truck with Special Dump Body. This Type of Truck Has Been Found Very Efficient by Builders Who Haul Great Quantities of Bulk Material from the Hopper to the Job. The Dump Body Cuts Out Delay.

Ambler Asbestos Shingles

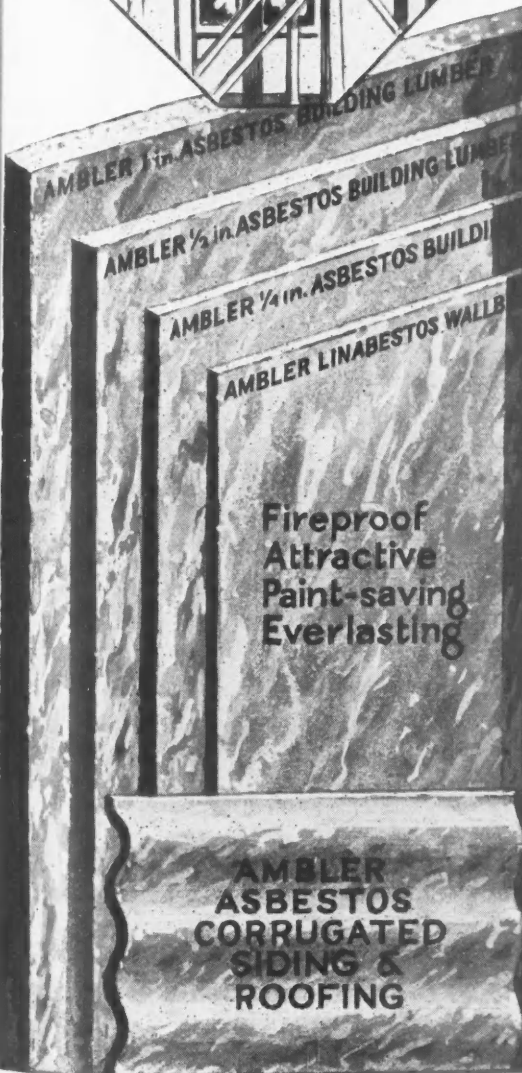

They give strength and permanence with attractiveness. They make tight, comfortable building that saves in painting and insurance.

You can't burn AMBLER ASBESTOS BUILDING PRODUCTS because they are composed of "unburnable" materials—long-fiber asbestos and Portland cement—rolled out with pressure of 3,000 lbs, or more to the square inch into convenient sizes and lengths for both interior and exterior work. Permanent colors made in the body of the material. No warping or cracking. Can be worked with ordinary tools.

Investigate Ambler Linasbestos Wallboard for every interior lining use,—partitions, wainscoting, hallways, libraries and game rooms, attics, bathrooms, kitchens, etc. Attractive buff color. Made 48 x 48, and 48 x 96, to fit standard joists.

For exterior use—half-timbering, paneling, fire doors, trim—and for interior use where unusual strength is required, call for Ambler Asbestos Building Lumber.

For a snug-fitting, attractive, thoroughly fireproof roof, use Ambler Asbestos Shingles in the American, French, or Honeycomb style.

You may have full information and specimens without obligating yourself.

ASBESTOS SHINGLE, SLATE & SHEATHING COMPANY

Dept. A AMBLER, PENNA.

Branch Offices: Atlanta, Baltimore, Boston, Buffalo, Chicago, Cincinnati, Cleveland, Minneapolis, New York, Philadelphia, Pittsburgh, Washington, Wilkes-Barre, Montreal, Canada, Toronto, Canada

Southwestern Distributor: R. V. Aycock Co., Kansas City, St. Louis, Tulsa, Houston

Western Distributor: J. A. Drummond, San Francisco, Los Angeles, Fresno

Other distributors throughout the country

Asbestos Shingle, Slate & Sheathing Co.

Dept. A., Ambler, Penna.

I am interested in:

- Ambler Asbestos Building Lumber
- Ambler Linasbestos Wallboard
- Ambler Asbestos Shingles
- Ambler Asbestos Corrugated Siding and Sheathing

Name.....

Business.....

Full Address.....

Hammering and Adjusting Circular Saws

KEEPING EDGE STRAINED ON STRAIGHT LINE IS IMPORTANT

ALL saws of whatever kind, if properly made, are what we call "loose," thru or toward the center to suit the speeds and different kinds of work for which they are intended. The object is to keep the edge strained on a straight line, to prevent it from chattering or cutting a zig-zag kerf thru the timber. The circular saw, however, is the most difficult to treat. Even after the most careful instructions, practical experience and close observation on the part of those having these saws in charge, is necessary before they can be successfully hammered, according to an article in the February Disston Crucible, published by Henry Disston & Sons.

The strain in running and the process of gumming will stretch the edge of the saw and it will begin to run snaky, rattle in the guides and make bad lumber. However, before concluding that the saw must be hammered to adjust the tension, see if there is not some other cause for the trouble, such as improper lining, the adjustment of the guides, the collars, the saw out of balance, and the dressing of the teeth. This means that it must be open sufficiently and properly from the edge toward the center to suit the motion of the saw and the feed of the mill.

The tools required are—anvil, one round face, and one cross-face hammer, two straight-edges—one from 14 to 18 inches long, one about 48 inches long—and one try-mandrel. We find that these tools for fitting up saws are being put in many of the large mills. The men who handle the saws are making themselves proficient in the hammering of the saws to suit their wants. This knowledge they have acquired by perseverance and practical experience, the only way in which it can be obtained.

In studying the subject of how to hammer circular saws, it would be well for those who have charge of the saws to examine them when first received for the tension assuming that they are correctly tensioned for the speed and conditions given when they leave the maker. Saws made by established firms are as true as it is possible to make them. Figure 1 shows a saw properly tensioned. It must be remembered, however, that different speeds and feeds call for different adjustment of tension. A saw that has lost its tension appears as that shown in Fig. 2, and needs hammering with a round-face hammer along the lines shown in Fig. 3A. Before commencing to

hammer to restore the tension, examine or test the saw all around with a straight edge. If any part of the saw between the rim and the center falls away from the straight edge, mark around this spot as shown in Figure 3B and do not hammer as much, if any, at that place. In testing for the tension be sure to have the straight edge at right angles with that part of the saw which rests on the board that extends back from the anvil and with the opposite edge which is being raised with the left hand. The straight edge is held and gently

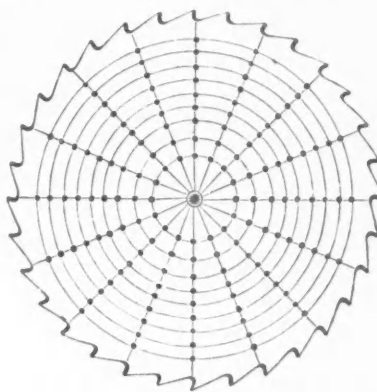

Fig. 3A. Dotted Lines Showing Where Hammering Should Be Done.

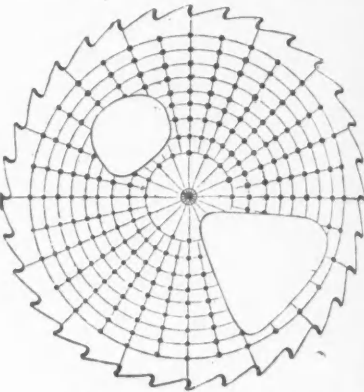

Fig. 3B. Spots Indicate Where Saw Between Rim and Center Has Fallen Away from Straight Edge. These Spots Should Not Be Hammered as Much as Other Parts of Saw.

pressed down with the right hand. Do not lean the straight edge to one side but hold it straight up or it will fall to the form of the saw and not show what is desired. A straight edge reaching from the center hole well out to the edge of the saw is the best to use to judge the tension in hammering, and when this straight edge is applied as above, the saw should fall away from a straight line. This will show that the center of the saw is stiff, as it must always be to run properly and do good work. If a short straight-edge about 6 inches long were pressed directly over the center it would show the saw to be nearly flat or of equal tension at that part. It is very seldom necessary to hammer a saw at the part covered by the collars.

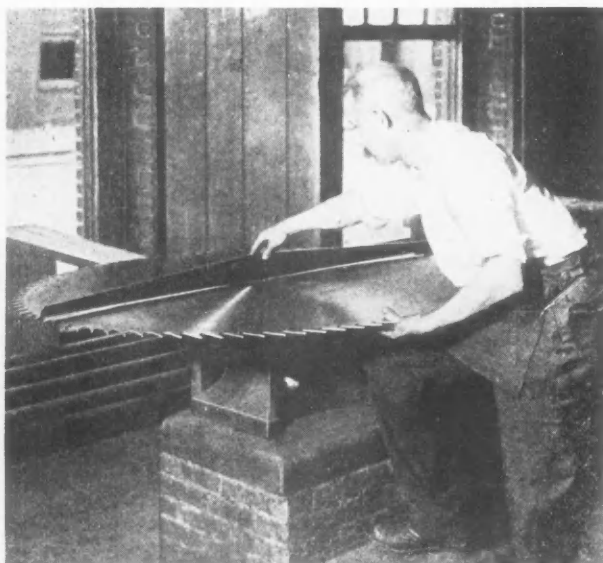

Fig. 1. Appearance of Saw Having Correct Tension.



Fig. 2. Appearance of Saw That Has Lost Its Tension. This Needs Hammering with Round-faced Hammer Along Lines Shown in Fig. 3A.



GENASCO LINE

- Trinidad Lake Asphalt
(For streets and roofs)
- Standard Trinidad Built-Up Roofing
- Bermudez Road Asphalt
(For road building)
- Genasco Roll Roofing
- Genasco Sealbac Shingles
- Genasco Latite Shingles
- Genasco Vulcanite Mastic Flooring
- Genasco Acid-Proof Paint
- Genasco Industrial Paint
- Genasco Boiler Paint
- Genasco Asphalt Putty
- Genasco Asphalt Pipe Coating
- Genasco Asphalt Fibre Coating
- Genasco Tile Cement
- Genasco Waterproofing Asphalt
- Genasco Waterproofing Felts and Fabrics
- Genasco Battery Seal Compound
- Genasco Mineral Rubber
- Genasco Mineral Spirits
- Genasco Base Oils
- Genasco Flotation Oils
- Genasco Motor Oils
- Genasco Soluble Oils
- Genasco Saturated Asphalt Felt
- Genasco Deadening Felt
- Genasco Insulated Paper
- Genasco Red Sheathing Paper
- Genasco Stringed Felt
- Genasco Wall Lining
- Genasco Road-building Machinery



What kind of roofings do you use and recommend?

Look over your roofing jobs. And whether it's a home or church, farm building or factory, apply this test to the roof—

Is it the best roof for the purpose—durable, economical and absolutely weather-proof?

Does it harmonize with the architecture—add to, *not detract from*, the charm of the building?

If a roofing fails—in any one respect—you *can't afford to use or recommend it*. And here's the reason—

People are looking at and appraising roofs as never before. And one poor roofing job—one dissatisfied client—can cost you heavily in prestige, good will and future business.

That's why it will pay you to concentrate on roofings of the GENASCO Line. Their quality—the highest—never varies, and they provide you with an attractive, long-lasting, economical covering for any type of building.

The success of Genasco Latite Shingles—"The shingles that lock on"—has been unprecedented. Their beauty, low cost and interlocking features have a tremendous appeal to building owners.

Write at once for illustrated booklet describing these wonderful shingles. Also other roofings and products of the GENASCO Line.

New York

Chicago

Pittsburgh

THE BARBER ASPHALT COMPANY
PHILADELPHIA

St. Louis

Kansas City

San Francisco

Atlanta

Genasco

Asphaltic Roofing, Flooring, Paints and Allied Protective Products

WHEN WRITING ADVERTISERS PLEASE MENTION THE AMERICAN BUILDER

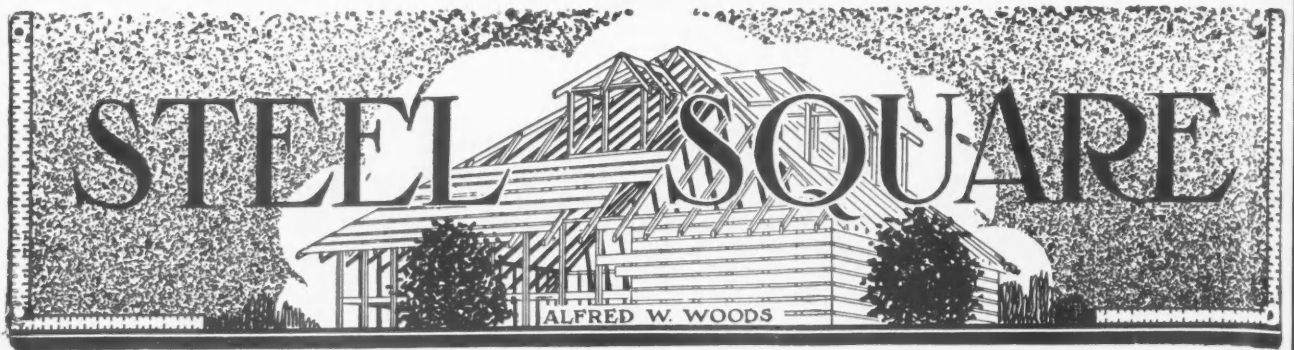

How to Use the Steel Square

SUBJECT OF MITERS IS SO IMPORTANT THAT FURTHER EXPOSITION OF NEW ANGLES IS DEEMED NECESSARY

FOR our subject this month, we will take miters again. We say again, because the charter members will remember that we pretty well covered the subject of miters in the early numbers of this paper, but as the AMERICAN BUILDER family is ever on the increase, and as thousands that are its readers now were not readers then, we feel justified in taking up the subject again, but in doing so, will endeavor to present it in a new light. Moreover, indirectly, our whole work from the beginning has been on miters. Roof framing might be regarded as miter work. It may be regular or irregular, part of the miters being on a level and part on an inclined plane, but they are miters just the same.

In looking up the subject, we find that the wise ones give it only as applying to a cut on an angle of 45 degrees. However, we believe it is universally understood to apply to the joining of two members at any angle and will treat it as such.

Now, let us go back to the beginning—to Mother Earth, as it were. Did it ever occur to you, that the reckoning point from which the angles for the miters are found are the same as that for the divisions of the

earth's circumference, by which the sailors at sea keep tab as to their location and pilot their way accordingly? The parts taken are the imaginary divisions encircling the earth's orbit from pole to pole, which are called degrees, and are 360 in number. Therefore, as the circumference of the earth is divided into 360 equal parts, the same holds true of all circular meas-

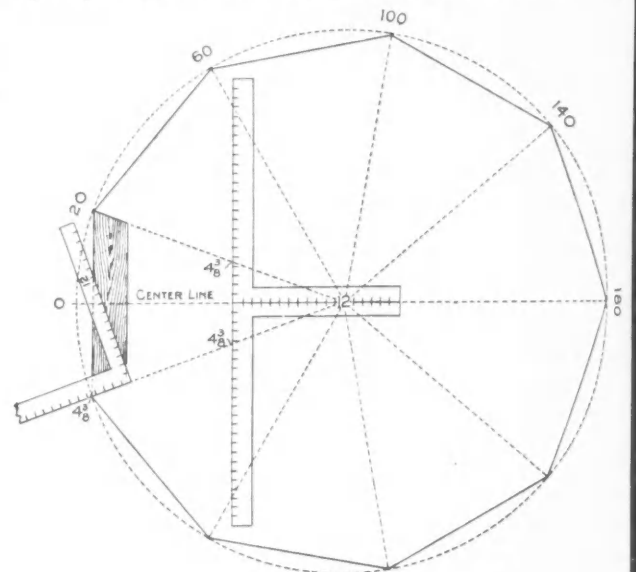

Fig. 2. Showing How to Obtain Angle of Miter with Aid of Steel Square

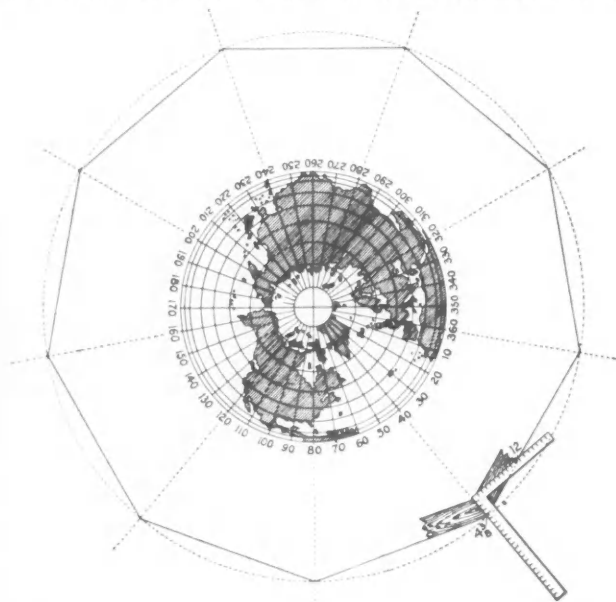
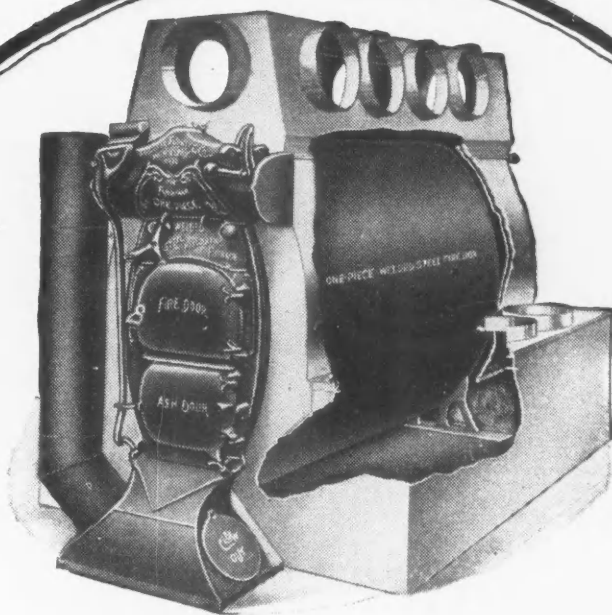

Fig. 1. Circle from Which All Angles for Miters Are Found. This Also Shows How They Are Obtained by the Use of the Steel Square.

urements or divisions. The miters, as we have said before, partake of these parts and may be obtained with the aid of the steel square; see Fig. 1.

A short time ago, while passing thru the campus of one of our state universities, we chanced to pass a beautiful sundial—a memorial erected by one of the graduating classes. On its marble face were engraved the hour and minute divisions, so that when the sun cast its rays across the stile, its shadows followed the markings and thereby indicated the time of day. But just at that particular time a cloud obscured the sun from view. There stood the sun dial, a mute witness ready to tell the time of day, but it lacked the necessary light to give the information it contained. It is just so with the steel square, which is to the degrees, as the stile is to the sundial. It is ready to give the readings of the most intricate problem; the informa-



What a Heating Engineer Said:

"Have read your literature. You have the right idea of ventilation and pure air. It does not take an expert to realize that the house furnace as commonly installed, is a source of foul heat and contaminates the air. Furnace gases pollute the air we breathe.

"There is something radically wrong with the accepted methods of house heating. After reading your literature, I believe you have solved this in a manner better than any other method of heating. You may send me your (Dealer) proposition."

The man who wrote the above is a prominent consulting engineer in New York—an authority on heating and ventilating methods. His letter expresses in a few words, the basic reason for our enthusiasm and persistence in emphasizing the importance of the

"FARQUAR" SANITARY HEATING SYSTEM

Sooner or later home owners must know that mere heat alone does not solve the heating problem. The dangers mentioned in the letter above are an ever present menace in thousands of homes.

That the FarQuar Sanitary Heating and Ventilating System successfully overcomes the difficulty, is proven by the hundreds of letters written by our satisfied customers.

Are YOU Willing To Be Convinced?

There is nothing mysterious about the construction or operation of the FarQuar Furnace. It is most sturdily built as proven by the hundreds of jobs in continual use for more than 20 years. The fire-box is made of No. 6 gauge Keystone Copper Steel, nearly 1/4 inch thick, which accounts for its sturdiness.

Send for Free Booklet and read the facts, then decide for yourself.

The Farquhar Furnace Co.
305 FarQuar Building
Wilmington, Ohio

**Sales
Representatives
Wanted**

The story of the
FarQuar

System is being told to thousands who are learning the truth about house heating for the first time. The demand for our product is increasing and we need live, responsible Dealers and Sales Representatives in every locality. Write for full particulars at once.

**Exclusive
"FARQUAR"
Features
and
What They Mean**

**Electrically Welded
One-Piece Steel Fire-Box**
Positively prevents contamination of air by gases or fire poisons.

Storage Fire-Box with large grate area insures slow combustion and fuel efficiency.

Vent and Return System. Provides a generous supply of gently warmed, pure, fresh air instead of a hot blast of super-heated air.

Automatic Regulator actuated by fire-box, completely controls fire, insuring uniform temperature regardless of weather, with surprisingly low fuel consumption.

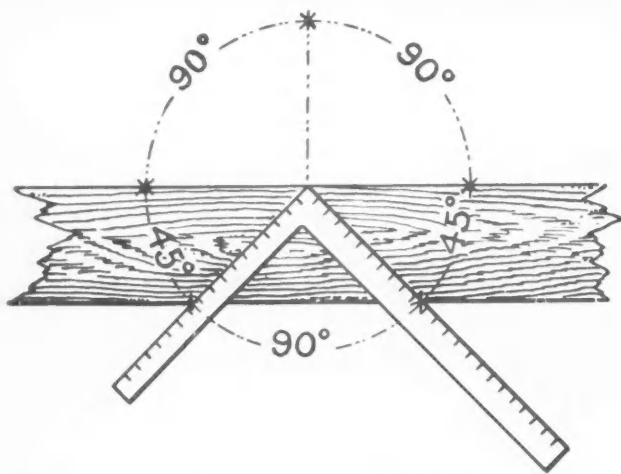

Fig. 3. By Placing Steel Square in This Position and Removing Part of Board Covered, the Carpenter Will Find the Two Severed Parts Form a Regular Miter.

tion is there; but we must have the intellectual light, and then all will be clear.

In Fig. 1 is shown the divisions as applied to the earth, and in connection with this is shown a circle divided into nine equal parts (called a nonagon). These parts are obtained by dividing 360 by 9; the quotient is found to be 40, which represents the required divisions in degrees of the circle, or the angle that the miter cut bears to the one at the opposite end of the timber that forms the side; but to obtain the angle with the steel square, the reckoning point is at the middle of the above angle. Consequently it is only necessary to take one-half of 40, or 20 degrees, on that instrument. This is illustrated in Fig. 2. The 20 degree line is found to pass at 4.37 ($4\frac{3}{8}$) on the blade; then 12 and $4\frac{3}{8}$ will give the miter as shown. It is better to work from 12 on one arm of the square for all angles, because it represents unity or the beginning from which to base other calculations, such as the length of the sides of polygons, which may be found as follows:

Say we wish to frame a nonagon, with an 8-foot inscribed diameter. Multiply $8 \times 4.37 = 34.96$ inches, or practically 2 feet 11 inches, which will be the length of the required sides. By using 12 on the tongue for

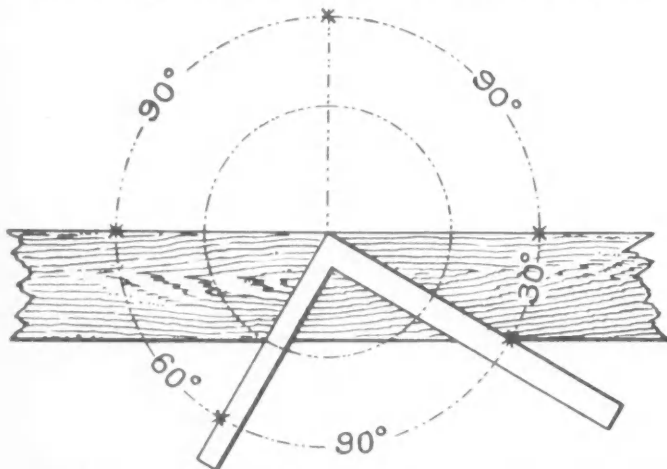

Fig. 5. Steel Square Placed at 30 Degree Angle. No Matter What Angle the Steel Square Is Placed on the Board, After the Space Covered Is Removed, the Two Remaining Pieces Will Form a Right Angle.

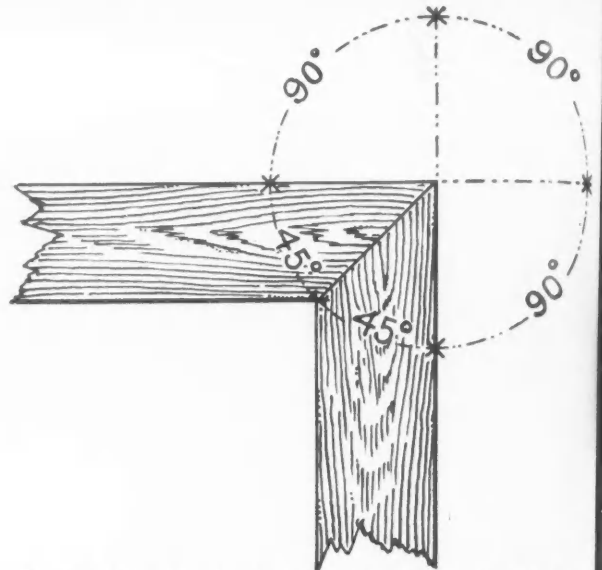

Fig. 4. Miter Formed from Operation Shown in Fig. 3.

the starting point, it answers for any cut up to a little over 63 degrees, when they pass off the blade. The blade in each case gives the cut. However, any angle in degrees can be had without going above 12 on the blade, because a line from 12 to 12 forms an angle of 45 degrees from either blade or tongue. This angle comprises $\frac{1}{8}$ of the circle, which is all that is needed in obtaining any angle with the aid of the steel square, because when the blade is giving a desired angle, the tongue will give the complement degree. That is, when the blade is set for 1 degree, the tongue will give 89 degrees. When one member is giving 30, the other will give 60 degrees. In the case of the nonagon, 12 and $4\frac{3}{8}$ give the angle for 20 degrees. The same figures will also give the angle for 70 degrees, because it is the complement.

The blade gives the angles for all cuts under 45 degrees and the tongue for all over that number. Therefore, the degree lines above 45 are simply a repetition of those below, as for instance, 36 degrees (12 and $8\frac{17}{24}$) will give the miter for the pentagon. The blade giving the cut. Fifty-four degrees (12 and $16\frac{1}{2}$), which is the complement, will give the same thing; but the tongue in this case will give the cut. It is better to use the first set of figures, because as we explained in the case of the nonagon, $8\frac{17}{24}$ is the proportion to use in finding the length of the sides.

Perhaps we can make this point clearer by applying the above rule to the most common of all miters, that for a square corner. Suppose we wish to find the miter for a square frame (tetragon). Divide 360 by 4 and the quotient will be 90, which represents the degrees of the angle and is also the same as that formed by the blade and tongue of the square to each other. This, when applied to the straight edge of a timber, would simply give the square cut, which is all right for the lap joint, but for the miter we must take one-half of 90 degrees, or 12 and 12, on the steel square. Either side in this case will give the miter

Carey



Roll Roofings of the Right Weight for Every Purpose

There are many roofing needs, but whatever your customer's requirements, the Carey line includes a Roll Roofing that is right and the best value for his purpose.

For a new warehouse or factory building, sell your customer the roofing you know will give lifetime service—Carey Flexible Cement Roofing, the heaviest roofing made, the oldest and best roofing on the market. If he has an old building which he is using for temporary purposes, sell him a cheaper roll roofing that is designed and priced for temporary use. He will think well of you for it.

There is a Carey Roll Roofing especially designed for every business and farm need. Give your customers the benefit of the complete Carey line. Write today for full information.

“A Roof for Every Building”

THE PHILIP CAREY COMPANY

510-530 Wayne Avenue, Lockland CINCINNATI, OHIO

WHEN WRITING ADVERTISERS PLEASE MENTION THE AMERICAN BUILDER

Other Carey Building Materials

Carey Built-up Roofings are built on the job with alternate layers of sheet roofing and coatings of Manco Asphalt. Permanent roofing for any kind of surface.

Carey Board is a Wall-board that is Waterproofed internally with asphalt and externally with paraffine. It takes the place of lath and plaster.

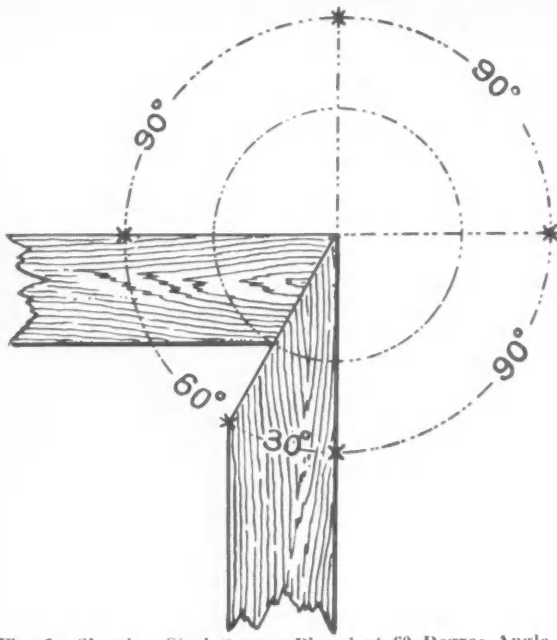

Fig. 6. Showing Steel Square Placed at 60 Degree Angle.

because like figures are on both blade and tongue. Aside from giving the miter, 12 on the tongue represents the diameter and 12 on the blade represents the corresponding length of the side. Simple enough. Every saw and hatchet man knows that, and if asked to cut the frame so that the diameter would be 6 feet, he would of course cut the pieces 6 feet long. But how many ever stop to enter into the real cause why

this is so? If it is 12 inches for one foot, for 6 feet, it must be 6×12 inches, or 6 feet. That being true for an equal sided square frame, it necessarily follows that the same rule applies to other equal sided frames. If we place the steel square with the heel resting at the center of a circle, the space between the outer edges of the blade and tongue will cover one-fourth the area of the circle. The straight edged board is 180 degrees and by placing the steel square with the heel resting just at the edge, with like figures on the blade and tongue at the other edge, and by removing that part covered, as shown in Fig. 3, the two severed parts when placed together will form the regular miter, as shown in Fig. 4. We took 90 degrees from the straight board (180 degrees) and have 90 degrees left, as shown in the latter figure.

In Figs. 5-6 are shown similar illustrations, but the steel square is in a different position. It is placed for the 30 and 60-degree angle.

Now, by removing that part covered by the steel square, as before mentioned, the severed parts will miter, as shown, making a 90-degree angle, as before, but the inner edges will not intersect. This shows that it does not matter at what angle the steel square is placed on the timber, after the space covered is removed, the two remaining pieces will always form a right angle.

10 Days Free Trial

Here is the Fastest Mixer of Its Size in the World

The reverse gear discharge of the KWIK-MIX is the reason for its remarkable speed.

IT IS the greatest mixer invention in years. Turns out as much thoroughly mixed concrete in a day as most larger capacity mixers. Small investment—low up-keep—fast work. It has no equal for mixing plaster, mortar or semi-dry concrete. The reverse gear discharge quickly forces out the heaviest, stickiest mixture.

KWIK-MIX

CONCRETE MIXER

The KWIK-MIX has features favored only on high priced mixers, such as gear tilting device, roller bearing, etc.—Complete line, from 2½ cu. ft. capacity to 5½ — with Loaders, Builders, Hoists, etc.

10 DAY FREE TRIAL

Before you buy any mixer, investigate the facts yourself—on the most up-to-date mixer—the KWIK-MIX.

Write today for new catalog. New reduced prices and liberal terms.

BADGER WIRE & IRON WORKS
1005 Cleveland Ave.
Milwaukee

\$51⁰⁰

Brings this mixer.

See how back of curved mixing blade, throws out mixtures as drum revolves

Brasco

COPPER STORE FRONTS

**DUPLICATE THESE
ATTRACTIVE STORE FRONTS
IN YOUR TOWN**

You know of many stores, no doubt, whose business would be greatly increased by an attractive store front. The store front is the most noticed part of these stores. Whether you pass, enter or come out of them, you see the entrance.



A great many store fronts are going to be remodeled this year. Storekeepers are realizing that the initial cost of installing Brasco fronts is the last, and once in place it means more business for them.

We want to help you get these remodeling jobs. They mean money to you. Let's work together—as a first step you send us the name of some storekeeper whose store front needs rebuilding. We'll help you land the job.

BRASCO MANUFACTURING CO.
5029 S. WABASH AVE. CHICAGO

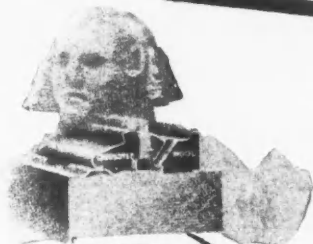

Will outlast them all

BRASCO MANUFACTURING CO., 5029 S. Wabash Ave., Chicago Ill.

Send me your book on Copper Store Fronts.

Name.....

Address.....

City..... State.....

How to Build for Steel Sash

METHODS OF BUILDING WALLS TO HOLD THIS TYPE OF SASH—HOW STANDARDIZATION OF TYPES HAS HELPED BUILDER.

SOME years ago if a builder intended to use steel sash, he had to build his structure to fit the sash, as each manufacturer made different sizes. Similar methods of construction could not be followed.

This trouble, however, has been eliminated by the standardization of sizes by the various manufacturers so that any standard construction method can be applied interchangeably to different makes. This has increased the use of steel sash on small construction jobs and has made the installation a comparatively simple task.

Today the builder in any part of the United States can get the size sash he needs from a warehouse within reasonable distance and receive shipment in a few days. He orders this material from a catalog just as he does many other kinds of building supplies. In many communities the lumber dealer keeps standard sizes of steel sash in stock.

Many builders are not sufficiently acquainted with the installation of this type of sash. Planning and building the walls to receive the sash is the first consideration, then comes the placing of the sash into position.

For factories, school buildings, public buildings, and the like the standard steel sash is mainly the pivot type made with one or two, or sometimes no ventilators.

This sash is made to fit narrow or wide openings, a simple T-bar mullion being used between sash units. As a general rule this type of sash does not call for a separate steel framework but is set directly into the



Newly Completed Evans Museum and Dental Institute, University of Pennsylvania, Philadelphia, Pa., Equipped with Special Steel Sash. Note the Adaptation of This Style of Sash to the Architectural Scheme.

walls, a feature which reduces the cost of construction, but emphasizes the necessity of constructing the walls properly to receive the sash.

Steel sash are made to hold glass and resist wind pressure but are not made to support bricks and masonry as some people are inclined to believe.

The walls must be subject to no further settling or buckling after the sash is inserted. That is why the lintel construction must be amply strong enough to carry its load without deflecting any portion of it upon the sash.

The general procedure for multiple unit openings is first to enter the end units in the jambs, then to set the remaining units and their mullions. The mullions are loosely bolted to the sash; then the sash are lined up and wedged, after which the bolts are tightened.

Where the sill is left unfinished, the sash are blocked up under their corners (so as not to distort the sash or bend the ventilators), and these blocks must not be removed until that can be done without allowing sash to sag. The head and jambs



One of the "Sunshine" Classrooms of the Medford School, Medford, Minn. This Town Is Small but Has Built a Modern School Building Equipped Thruout with Steel Sash. The Structure Is an Excellent Example of the Best in Schoolhouse Construction.

Fenestra Steel Basement Windows

Can Be Installed Equally as Well in Concrete Block, Brick and Natural Stone

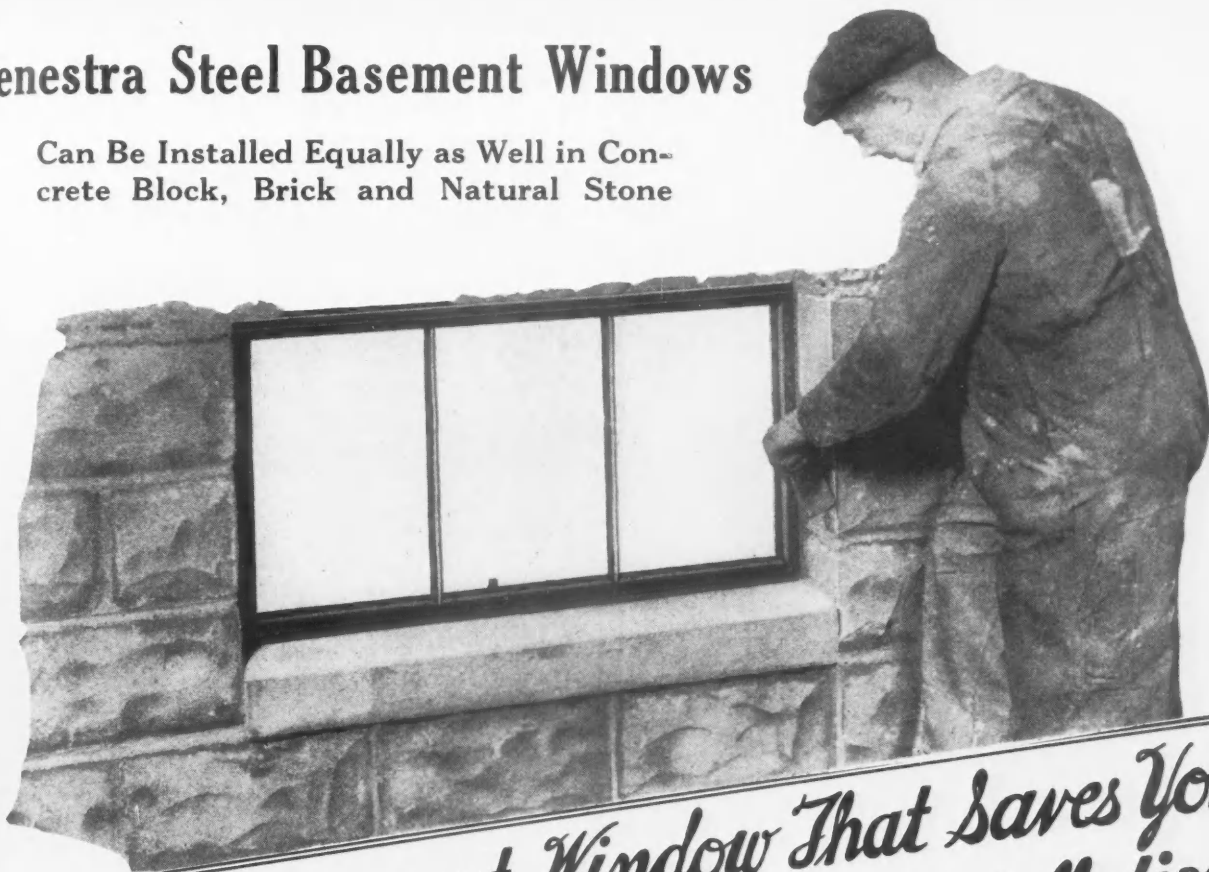

A Steel Basement Window That Saves You Money in two Ways—Original Cost & Installation

FENESTRA STEEL BASEMENT WINDOWS will save you money. They **cost no more than wood windows** and in many cases **less**.

Another worthwhile saving is in installation. First, Fenestra Steel Basement Windows come complete—no extra frames—no planing or fitting of sash—no hardware to buy or attach—no labor to brace up frames—and they're painted.

Second, the methods of installation are simple and practical. They can be installed quicker and better than wood windows. Many contractors have effected a saving of as high as a dollar per unit!

In addition, the many added advantages of steel windows over wood will give your customers greater satisfaction.

Send for the booklet described at the left. Learn the whole story of Fenestra Steel Basement Windows including the details of installation.



This Booklet Shows You More Facts About How to Install FENESTRA Steel Basement Windows

WE will be glad to send you a copy of this booklet which fully illustrates and describes FENESTRA Steel Basement Windows including the methods of installation. Just clip this corner, sign your name and address, mail it, and we'll do the rest.

Fenestra

STEEL WINDOW WALLS

Detroit Steel Products Company
2243 East Grand Boulevard, DETROIT

TRUSCON STEEL BASEMENT WINDOWS

Truscon Steel Basement Windows have obtained immediate popularity and are in demand by builders everywhere, because:

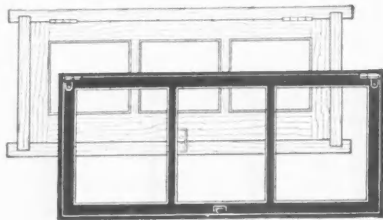

Reduces your lighting bills and Truscon Steel Windows make your basement bright and cheery.

50% to 80% more daylight

Easy opening and automatic locking are features of Truscon Steel Basement Windows.

Continuous double overlapping weathering is to be had exclusively on Truscon Steel Basement Windows.

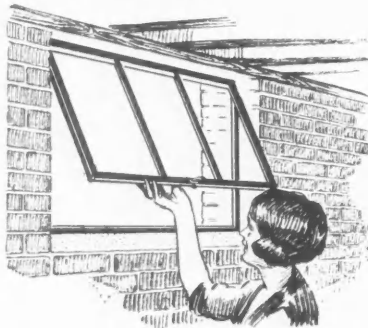

won't stick or warp

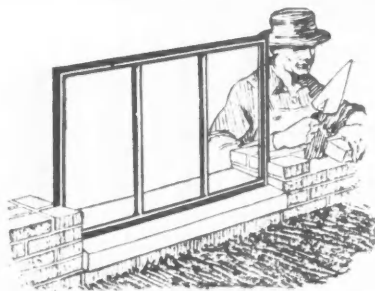

Also easily screened. In any type of foundation it is a simple matter to install Truscon Steel Basement Windows.

as easily installed

Actual figures in many localities have shown lower costs for Truscon Steel Basement Windows.

COST OF WOOD WINDOW		COST OF TRUSCON WINDOW	
ONE SASH\$ 3.00	FURNISHED COMPLETE INCLUDING FRAME, SASH, HARDWARE, AND COST OF PAINT.	...\$ 4.75
ONE FRAME\$ 2.00		
HARDWARE\$.25		
LABOR OF FITTING\$.50		
PRIMING COAT\$.50		
TOTAL	\$ 6.25		

and COST as little as wood

TRUSCON STEEL COMPANY
 YOUNGSTOWN, OHIO

Home Builders! Write today for details. Dealers! Get our attractive dealer plan.

TRUSCON STEEL COMPANY, Youngstown, Ohio.

I am interested in Truscon Steel Basement Windows.
 I am an owner, architect, contractor, dealer, .

Name _____
 Address _____



Garage of T. T. Watson, Wayne, Pa., with Steel Sash. There is the Balanced Ventilator Type Used Frequently in Smaller Buildings.

are not grouted until sills have been finished.

Sills of cut stone or pre-cast concrete blocks must be finished before the sash are set, and this necessitates using a different form of lintel from that permissible with unfinished sills. The sash are set in the same general manner, except that they rest directly on the sill without blocking.

After sash are finally lined up and bolts and wedges tightened, they are grouted or otherwise secured at the head and jambs.

Free drawings are available that show details for all commonly-used types of walls, namely, brick, concrete, stone, tile, steel and wood. Where stucco is used over steel or wood framing, details for concrete, steel and wood may be used.

The commonest form of brick jamb consists of a wood strip (like a lath) about 3/8 inch thick and one inch wide is inserted in the brick joint next to the outside face of the wall. Instead of using wood strips, the mortar may be raked out after the bricks are laid. The flange of the frame member is inserted into the groove 5/8 inch. The groove and the space between the frame member and the brick are grouted after the sash are lined up. This detail can be used only when two or more sash units are used in an opening.

The sills may be set before sash are inserted. If, however, only one sash is used in an opening, care must be taken to place the sill low enough to allow the top member of the sash to clear the lintel when one side of the sash is inserted in the jamb.

Terra cotta blocks are made in certain widths, which may be combined to suit the mullion spacing of standard steel sash. The head and jamb may be used and the sill may be set either before or after sash are erected.

Wood lintels may be of a great variety of forms.

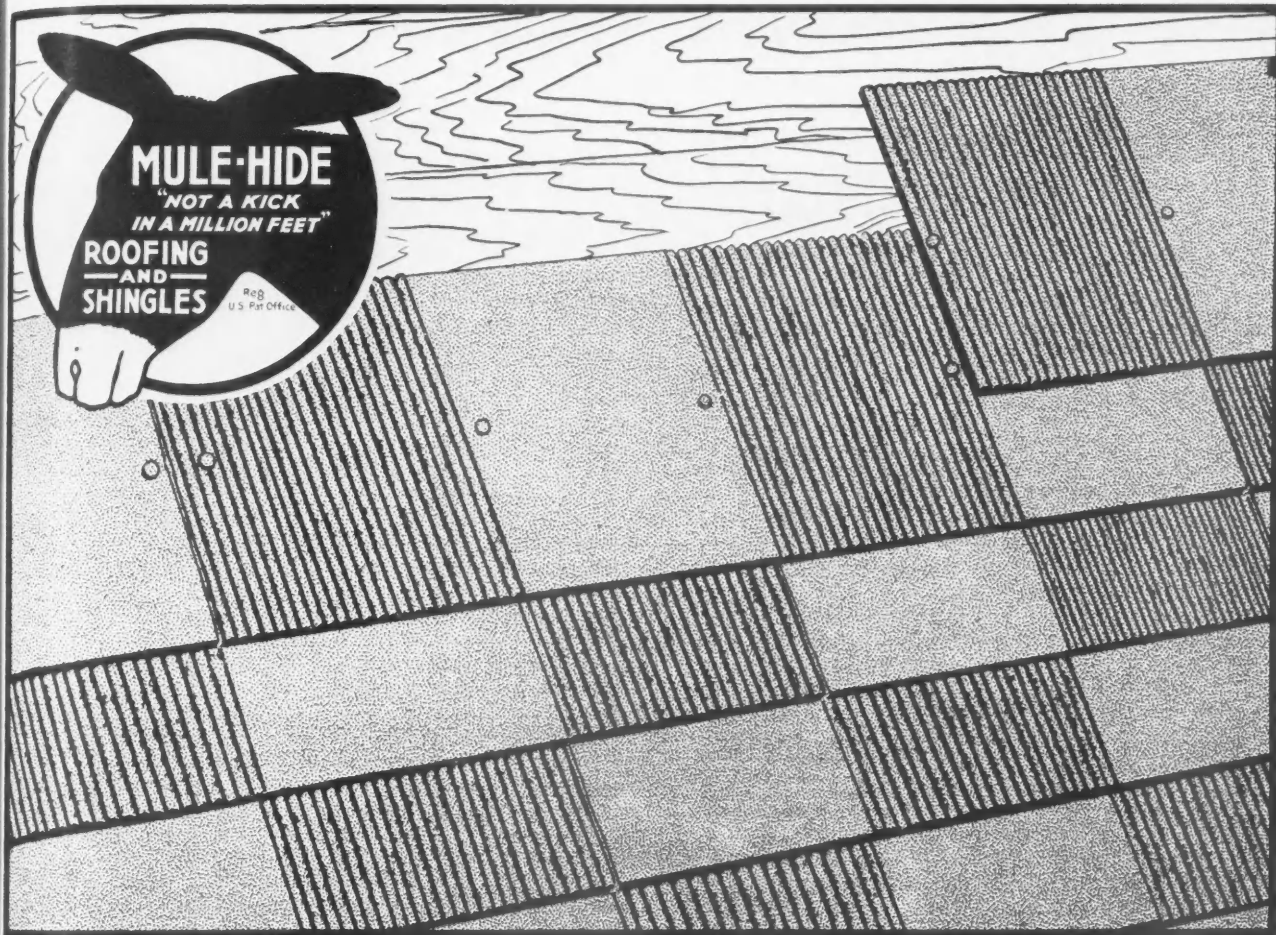

"Not a Kick in a Million Feet"
MULE-HIDE
COR-DU-ROY
PANEL STRIP SHINGLE

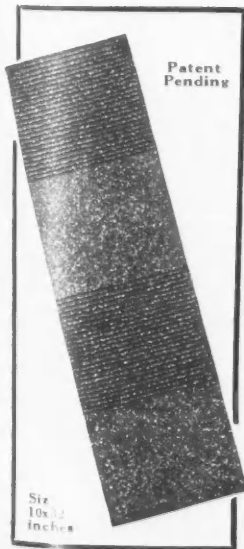

Success From the Start

This beautiful new Cor-Du-Roy Panel Strip Shingle is the result of the unusual success and popularity of the now famous Cor-Du-Roy. The beauty of this strip shingle is doubly enhanced by the contrasting effect of the plain slate surface that forms a background for the Cor-Du-Roy panels.

A most artistic effect can be made by alternating the plain and Cor-Du-Roy panels, giving a two-tone bonded effect. The diagonal shadow pattern is another attractive way of laying the panel strip to give the appearance of tile. From an artistic and practical standpoint, the Cor-Du-Roy Panel Strip is a fast winning favorite with home owners everywhere.

Cor-Du-Roy Panel Strip Shingles

eliminate the ordinary slot of the Four Unit Shingle and with it all possibility of this shingle blowing up in the wind. The solid block construction prevents curling, and assures a complete two-thickness over the entire roof. The combined advantages of this panel strip provide the most attractive, enduring and satisfactory shingle on the market.

Write for your sample shingle of Cor-Du-Roy Panel Strip.

The Lehon Company
 45th and Oakley Avenue
 CHICAGO ILLINOIS

COUPON—CLIP AND MAIL TODAY!
 I am interested in COR-DU-ROY Panel Strip Shingles
 Dealer Contractor Architect
 Name.....
 Town.....
 State.....

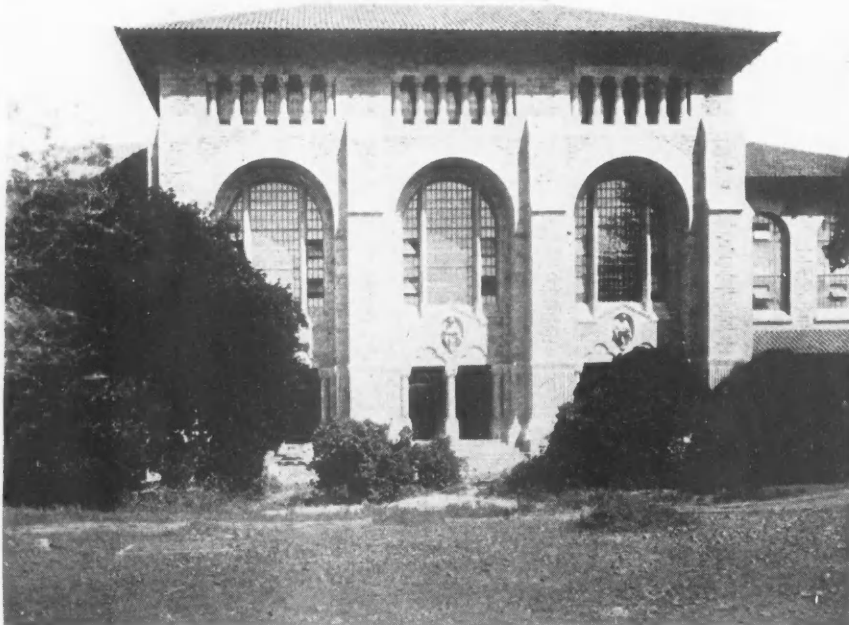

Many People Think of "Factories" When Steel Sash Is Mentioned. Here Is the Library of Leland Stanford, Jr., University, Palo Alto, Cal. Not Exactly a Factory, Altho some of the Students May Think So.

The sill must be left unfinished until sash are in place.

With wood sills it is not commonly considered essential that the lower ends of the mullions shall enter the

sill; they may be sawed off. The bottom frame members of the sash, however, should be securely screwed to the sill.

After the sash have been erected the jambs are completed by nailing inside and outside strips, $\frac{5}{8}$ inch thick.

Glazing is done from the inside, using a special steel sash putty which remains slightly plastic indefinitely. Putty which dries hard cracks out too soon and should not be used. The lights are bedded in putty so that there is no contact between sash and glass. They are held by spring wire clips over which the back putty is applied and beveled.

If sash have not been damaged by rough handling in transit or distorted during erection, the ventilators will work freely. If a ventilator binds it can be straightened by a little bending or hammering before sash are glazed.



OF wood pulp, Sweden exports to the United States more than any other country except Canada.

Insure Your Floors and Ceilings

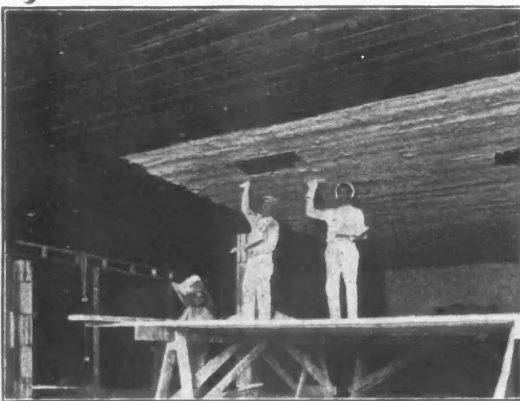

Putting the scratch coat on ceiling lathed with Truscon $\frac{3}{8}$ " Hy-Rib

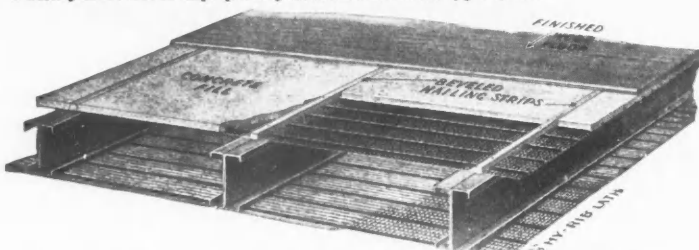

Cross sectional view of typical ceiling and floor built with Truscon Steel Joists and $\frac{3}{8}$ " Hy-Rib Metal Lath

In the school, apartment, office or public building, floors and ceilings should be fire-proof and soundproof.

Truscon Steel Joists and Hy-Rib Metal Lath make the logical combination to fill the most exacting conditions.

Truscon Steel Joists are designed for all types of construction not requiring excessive floor loads. The Joists are manufactured in sizes and weights that will support single spans up to 24 ft. in length.

Truscon Hy-Rib Metal Lath insures plastered walls and ceilings against cracks. Concrete reinforced with Hy-Rib makes a floor of exceptional rigidity and strength. For sidewalls, partitions, roofs and concrete stucco work of all kinds, Truscon Hy-Rib Metal Lath is unexcelled.

If your estimates are based on quality your customers will be glad that you specified Truscon.

Truscon Building Products means permanence without extra cost.

TRUSCON STEEL COMPANY
YOUNGSTOWN, OHIO

Sales and Engineering Offices in Principal Cities

More Than 300 Dealers Carry Truscon Building Products in Stock

KELLASTONE

IMPERISHABLE STUCCO

PLASTIC as clay in the hands of an artist, **Kellastone** yields itself readily to the free expression of the minutest architectural detail. Yet once applied, it turns to a stone-like material.

So genuinely artistic, so staunchly reliable, and so economical, it has enabled many a small building to raise its head proudly amongst those of more pretentious architecture.

KELLASTONE

IMPERISHABLE STUCCO

is the original, all-mineral, magnesite stucco, no cement, lime or gypsum in its composition. For cool comfort in summer, warmth in winter, and a weatherproof and firesafe building at all times, specify **Kellastone**. Write today for the "Story of Kellastone".

National Kellastone Company

ROOM 515
155 E. Superior Street
Chicago, Illinois



Look for the name **KELLASTONE** on every sack. It will insure you against the disappointing discovery that "all magnesite stucco is not **KELLASTONE**".

Riddle

DECORATIVE LIGHTING FITMENTS

Riddle Feature Fitment in 5-drop light style. Other styles include ceiling and wall lights for all major rooms of residence or apartment.



If you are building or planning new homes or apartments do not fail to get full information about this wonderful new lighting fitment.

The RIDDLE FEATURE FITMENT

A revelation in beautiful lighting fitments at moderate cost

All cast metal, decorated in Gold Estofado and Silver Estofado, like the finest Riddle Fitments.

Specially planned for the small home, apartment or bungalow, but equally desirable wherever a beautiful, moderate-priced fitment is desired.

The price at which this beautiful fitment can be installed is proving a sensation.

Ask your fixture dealer, or write us direct. Illustrated folder showing the Feature Fitment in actual colors free on request.

The Edward N. Riddle Company
352 Riddle Building, Toledo, Ohio
Makers of Lighting Fitments Since 1892

Design of Safe Construction

(Continued from page 121.)

expression for moment is $M = Wl \div 10$. Now assuming a strip along the diameter of the base, the length of the slab will be 8.75 feet since the walls are $8\frac{1}{2}$ inches thick. Then $M = (25 \times 144 \times 8.75 \times 8.75 \times 12) \div 10 = 331,000$ pound inches due to load on the slab. One-half of this moment will be taken by the strip at right angles to the above. There is to be a manhole 18 inches in diameter at the center of the slab, and in consequence it will be necessary to consider a moment due to concentrated loads. There will be a pressure against the manhole cover equal to $3,600 \times \pi (\frac{3}{4})^2 = 6,360$ pounds. One-fourth of this load will be supported by each strip adjacent to the manhole. In addition, the strip between the manhole and the circumference must be supported at one end by one of our assumed beams. The additional load on the beam at the center will be $(3,600 \times 1.5 \times 3.25) \div 2 = 8,775$ pounds. The total assumed concentrated load for each beam thru the middle of the slab will be $8,775 + 1,590 = 10,365$. The moment due to this load is $M = Pl \div 8 = (10,365 \times 8.75 \times 12) \div 8 = 136,000$ pound inches. Total moment to be resisted by the beam will be $(331,000 \div 2) + 136,000 = 301,000$ pound inches. The positive and negative moments will be the same amount, and the steel will accordingly be continuous thruout the slab, both at the top and bottom. It will be desirable to avoid the necessity of web reinforcement, and in order to do so, the cover slab should have a depth $= 7,200 \div 60 \times 12 = 10$ inches effective depth. The steel area required to resist either positive or negative moment will be $M = Asfsjd$ and $301,000 \div 16,000 \times 10 = 1.89$ square inches.

To secure this area of steel, select three $\frac{7}{8}$ -inch round, or three $\frac{13}{16}$ -inch square rods, space four inches on centers.

The diametral areas d-e between the manhole and the outer edge of slab will require reinforcing as follows: $M = Wl \div 10$; $3,600 \times 3.5 \times 3.5 \times 12 \div 10 = 53,000$ pound inches, then $As = 53,000 \div 16,000 \times 10 = .331$ square inches. Use three $\frac{3}{8}$ -inch rods spaced four inches.

For the reinforcement continuous across the slab and midway between the center and edge of plate, 1.5 square inches would be sufficient. Use $\frac{3}{4}$ -inch square rods spaced four inches. These figures constitute the most important details of the design. In making the computations for the cover of the tank, a steel stress of 16,000 pounds per square inch is used. This stress is justified because of the thickness of the slab, and the further fact that no water touches the cover. All of the stress, both tensile as well as compressive, is taken by the steel. If the concrete acts with the steel and takes its proportion of the stress, this assumed steel stress is much reduced.

The thickness of the wall is somewhat arbitrary, but is seldom less than six inches.

THE IDEAL CONCRETE MACHINERY CO.

Ideal Automatic Concrete Block Machines

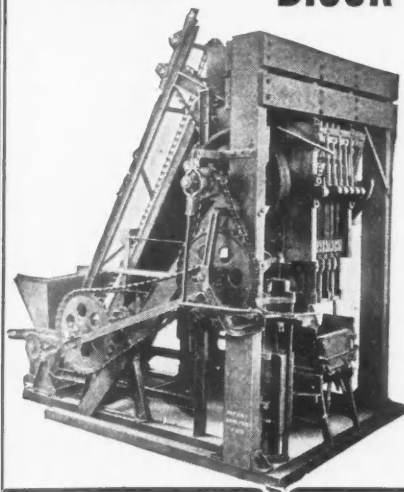

turn out square, true blocks in 12 seconds — ONE motion instead of 23! All ready for delivery—let us send you Catalog 35—see how you can become a leader in Spring building operations.

Specialists in

all modern equipment for the prompt production of machines for concrete blocks and tile and ornamental molds.

Our Fully-Automatic Building Tile Machines

deliver three tile on a single wooden pallet continuously, with no stopping or delay for off-bearing of tile. Pallets are changed while machine is working on next batch, insuring continuous operation. Only 3 men required to operate this machine; 1 on mixer at back, 1 to place empty pallets in the machine; and 1 to carry away the full pallet. WRITE for ALL THE FACTS TODAY.

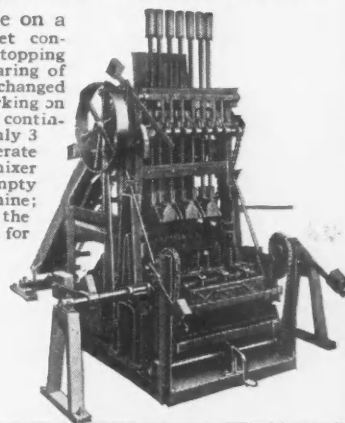

The Ideal Concrete Machinery Co.
1336 Monmouth Street Cincinnati, Ohio

BOGALUSA'S HISTORY-MAKING REFORESTATION OPERATIONS ASSURE A PERPETUAL SUPPLY TO OUR TRADE

"'BOGALUSA' STENCILED ON YOUR SOUTHERN PINE IS LIKE A CERTIFICATION ON A CHECK"

BOGALUSA

Trade-mark Registered U. S. Patent Office

Can fill any order of ANY SIZE ANY TIME through your favorite retail yard, with promptness and exactness. Big Timbers for Railroad or Marine demands—or humble everyday crating, or box lumber (as well as a Complete Line of the usual yard and shed stock).

25 YEARS of CAPACITY PRODUCTION ahead of us in our own unequalled stands of THE FINEST VIRGIN TIMBER EXTANT, plus the knowledge of "BOGALUSA" products assured to you IN PERPETUITY by our far-reaching reforestation operations. You are thus protected, in the most practical way, in the complete satisfaction of your trade during the life of your business.

Superior standards of manufacturing technique, with strict grading per Factory Mutuals, A. S. T. M. and A. R. E. A., accuracy of count and a simple "good-will policy" are a few among the other factors that have made the name "BOGALUSA" indeed

"A WORD TO BUILD ON"

Dealers: Write us for full particulars as to detailed special service on special items. Our response will be personal, candid and prompt.

SALES SERVICE DEPARTMENT

GREAT SOUTHERN LUMBER COMPANY 1600 4th Avenue, BOGALUSA, LA.

"FROM A LATH TO BRIDGE TIMBERS, SPECIFY BOGALUSA TRADE-MARKED PINE AND REST EASY"

Machine Cleans 16,000 Brick in Eight Hours

ONE of the latest inventions in building machinery is a brick cleaning machine with a capacity of 16,000 brick in an eight-hour day, or at the rate of 40 per minute. This machine automatically cleans the mortar from all sides and ends.

The bricks are fed in from the right side (see photograph). The first set of cleaners removes the mortar from the wide side. The second set removes the mortar from the edges and the last set removes the mortar from the ends. The bricks are handled by this machine automatically without their changing position in passage thru the machine. It is also designed to clean bats that are at least one-half length.

An elevating section is furnished with each machine at the discharge end. This elevating section attaches to the discharge end and the bricks pass into it and are conveyed either to a truck or into a pile beside the machine. This elevating section can be raised or lowered as pile increases in height to prevent damage to the bricks from falling.

While two or three men can work to advantage on this machine, one man can operate it. After the engine is started all that is needed is to get the brick to the machine to be

cleaned and away from the machine when finished. It is operated by either electric or gasoline power.



New Roofs from Old Rags

(Continued from page 127.)

with this problem that the variegated roof idea was developed, and now many architects are specifying the variegated roof extensively because it is possible with this medium to produce a predominating green effect or predominating red effect, in various shades which are all harmonious.

In laying a variegated or tapestry roof with asphalt shingles, care must be taken to avoid everything in the nature of a pattern. The shingles must be thoroughly mixed and the roofer instructed not to lay more than three individual shingles of the same color on the same course or parallel courses. The Prepared Roofing Association is sponsoring the variegated asphalt roof and will issue colored charts to illustrate how certain

very attractive effects can easily be produced. If, for example, a general green effect is desired, then approximately 75 per cent of the shingles should be green and the balance red, or 15 per cent and 10 per cent black.

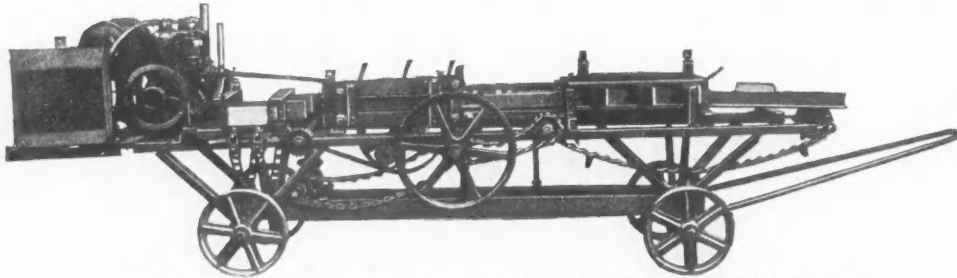

Brick Machine with Capacity for Cleaning 16,000 Brick Every Eight Hours.

The Modern Way of Heating

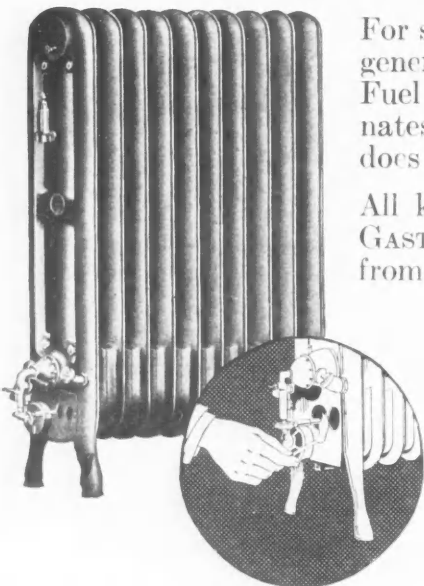

For small houses, particularly, CLOW GASTEAM radiation—generating steam heat without coal—is the ideal system. Fuel is paid for as used and delivered in a pipe. It eliminates the cost of basement, chimney, boiler and piping. It does away with dirt, ashes, and tending a furnace.

All kinds of buildings are successfully heated by CLGW GASTEAM. Installations—which are easily made—range from a single radiator to hundreds.

CLOW GASTEAM radiators are staunchly built of cast iron and will last indefinitely. Their operating cost is low. You can sell them on easy payments. Let us explain our plan.

JAMES B. CLOW & SONS

General Offices: 534-546 S. Franklin St., Chicago
Sales offices in the principal cities

CLOW

James B. Clow & Sons
534-546 S. Franklin Street, Chicago
Send me details of CLOW GASTEAM.

Name _____

Address _____

We Offer Real Profits to the Contractor

The "Boiler Plate" Pipeless Furnace is of heavy boiler plate steel construction ($\frac{3}{16}$ " thick), with all seams riveted same as on steel boilers. It will not leak. It will last. And it will burn all kinds of fuel—hard or soft coal, coke, wood or gas.

The Many-flue Feature. We have taken a great deal of pains to work out theoretically and experimentally just the right proportion of the heating surface and air flow areas to obtain the maximum results of efficient and economical heating.

80 extra square feet of air contact surface.

The simple construction of the "Boiler Plate" Furnace makes it very easy to install.

Suitable for pipeless work or as a regular pipe system.

GUARANTY. Each "Boiler Plate" Furnace is guaranteed to heat the house satisfactorily. Your money back if you want it after 3 months' trial.



In our "Boiler Plate" Pipeless Furnace

You can buy a Sample Furnace at Our Special Sample Furnace Price.

Then watch your orders grow for Boiler Plate Pipeless Furnaces.

Your customers will want this gas-tight, smoke-tight, dust-tight economical furnace.

Ask for Our Catalogue and Agent Details on all kinds of Heating.

Andrews Heating Co., 1589 Heating Bldg., Minneapolis, Minn.
 Please send Catalog and Agent's Offer
 Name.....
 Address.....
 Town.....
 State.....

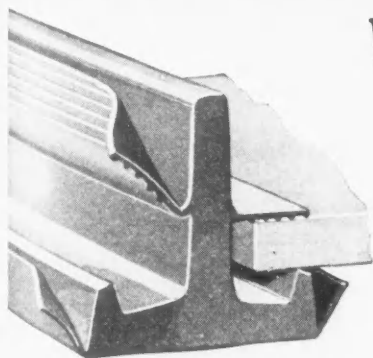

Cross Section of STEELED BAR Showing Lead Wings

Why STEELED SKYLIGHTS Are Everlasting

Lead is practically indestructible—it resists rust, corrosion and erosion. The entire surface of STEELED Construction is *lead*—everlasting. The core is steel—making STEELED Skylight self supporting. The initial cost of STEELED is the last cost—for

STEELED Skylights Need

No Paint No Packing
 No Putty No Renewals

For Satisfaction Specify Steeled

AMERICAN 3 WAY-LUXFER PRISM COMPANY
 SKYLIGHT ENGINEERS

1307 S. 55th Street, CICERO, ILL.

139 Spring Street, NEW YORK

lock should not be more than $\frac{1}{2}$ inch as shown in X, so that any water soaking in this edge can only fill the lock as high as *a* and then overflow. The lock shown at X should be closed tight. Care must also be taken when constructing the gutter, that point 6 is lower than point 1 as indicated at F, so that in case the gutter overflows, it will run over the front edge before it can overflow at 2, inside the building.

When nailing on the wood battens, they should be made flush with the copper gutter edge at B and then cut off plumb or they can be cut at an angle as shown in diagram Y by *b-c*, making the cut from the front edge *b* to the rear line of the gutter *c* as shown by the dotted line. When the copper lining flanges on to the roof, as shown in diagram Z, then the locks must be made of the same dimensions as shown in diagram X, notching out the bottom of the wood battens at *a*, so that the lock will not be crushed and cutting the front end of the wood battens from the front edge of the lock to the rear bend as from 1 to 2.

Finishing Batten Copper Roof at Gable End

Fig. 19 shows how the copper roofing finishes against the gable end. A half wood batten is nailed at X and the copper roofing sheet bent in the usual manner. An angle cap made of soft or cold rolled copper is then bent as shown, locking it at *a* and nailing and covering the nail heads at *b*. Of course, copper nails are used and the lock is closed at *a* as already explained, and the nail heads covered along *b* as shown.

Finishing Batten Copper Roofing at the Ridge

The method of finishing the ribbed or batten copper roofing at the ridge is shown in Figs. 20, 21, 22 and 23. The first operation is shown in Fig. 20. A wood batten is nailed along the ridge of such height, that the battens will meet at *i*. The copper sheet A is then turned up at the top and sides, with a locking flange as indicated at *t*. This flange is shown cut away at the corner, so as to more clearly indicate how the dotted lap *a*, should be turned on the bent-up side and thus help to secure a solid soldered joint from 1 to 2. Before the sides of the sheets are turned up, the proper edges must be tinned to facilitate soldering.

Cleaning and Coloring the Copper Work on Completion

After all the copper work is completed and before the scaffolding and ladders are taken down, rub off the copper with some cotton waste or old rags saturated with boiled linseed oil, and this will, in a few weeks, give that dark bronze color and prevent green streaks. If it is desired that the copper work turn to a rich green tint, then make a solution of one pound of sal-ammoniac to five gallons of water; let it stand for one day and then apply to the copper roof with a brush, let it remain one day, then spray on clear water, just to moisten the copper. In 24 hours the desired tint is the result. The same results are obtained by using a solution of one-half pound salt to two gallons of vinegar.

BUY A HANDY CONCRETE MIXER DIRECT FROM THE MANUFACTURER AND SAVE MONEY

WHEN
BUYING
HANDY
MIXER
DIRECT
YOU ONLY
PAY ONE
SMALL
MFG'S
PROFIT

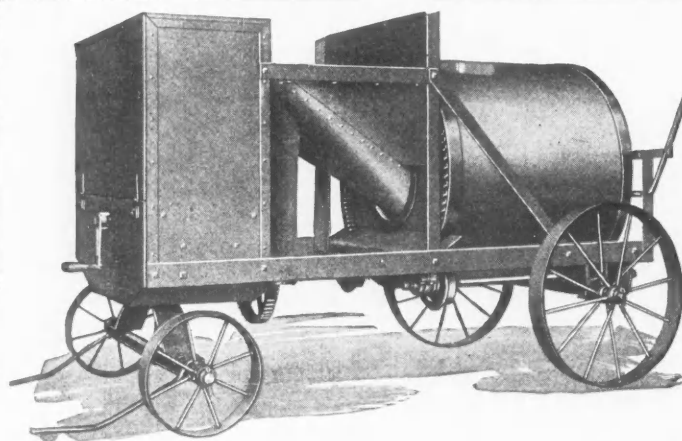

THE
MOST AND
BEST
VALUE
IS HAD
IN HANDY
MIXERS
FOR YOUR
MONEY
TRY ONE

FOR PRICES—ADDRESS
THE BOLTE MFG. CO.
1ST AVE.
KEARNEY, NEBRASKA

WONDER DIAPHRAGM PUMPS

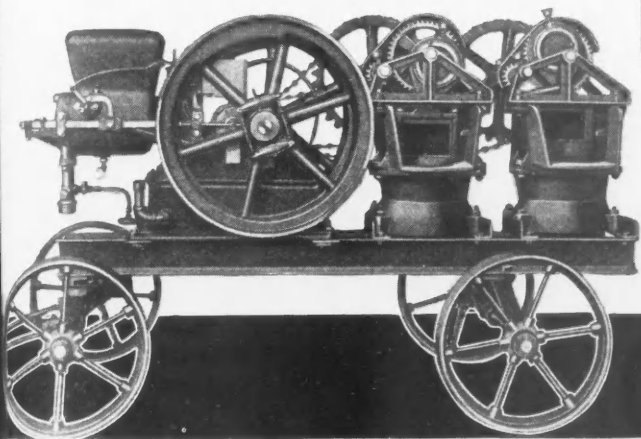

WONDER Diaphragm Pumps by departure from the usual walking beam design, have accomplished advantages that are economically worth while.

They attain, size for size, a greater hourly capacity with less weight and considerable less initial investment.

Literature fully describing the design that makes this possible will be gladly furnished on request.

Construction Machinery Company

Formerly

Waterlo Cement Machinery Corporation
103 Vinton St.
Waterloo,
Iowa

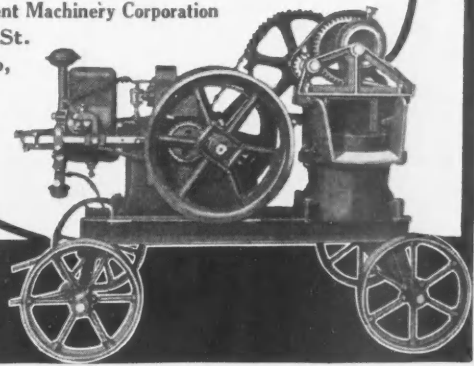

CROPP

LOW CHARGING---SPEED MIXER

Built to accommodate big jobs at maximum speed. The large wide open drum eliminates spilling material in loading.

CHARGING—Three-way action of the blades give a thoro mix in rapid time.

DISCHARGING—Thirty inch above ground level. No blocking up necessary. A wheelbarrow at each revolution.

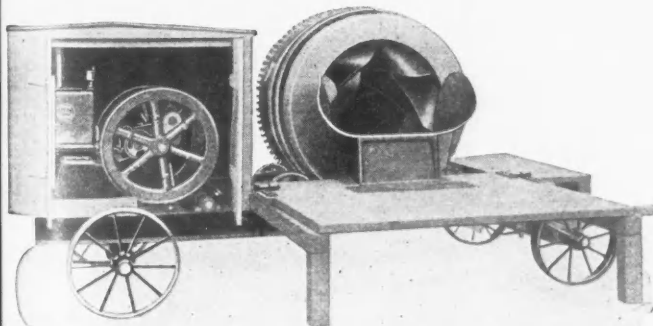

**Compare Our Prices and
Cropp Performances Before You
Select Your Equipment**

Desirable territory
still open for active
representatives.

B. M. CROPP CO.
2334-40 W. KINZIE ST., - - CHICAGO

Waterproofing Basement Walls

(Continued from page 123.)

Water follows the line of least resistance. If, for example, water appears to be seeping thru the floor of a basement only, it is not good practice to be content with applying a 2-inch waterproofed cement finish to the floor, and expect the basement to be waterproofed. Because, water finding its passage obstructed at the floor, will simply work its way around, and probably make its appearance somewhere thru the walls.

A 3/4-inch plaser coat should be used on all walls of structures it is desired to waterproof, and it is advisable to run this plaster coat to at least a foot above grade line. A 2-inch waterproofed cement finish should be applied to the floor, making the finish continuous with the plaster coat so that there is no opportunity for water to force its way thru a possible joint. For this reason the floor at its point of juncture with the wall is routed out a little deeper.

The waterproofed cement mortar is prepared by thoroly tempering (to required consistency) a dry mixture of one part of cement and two parts of sand, with water to which waterproofing paste, concentrated, has been added in the proportion of one part of paste to eighteen parts of water, as directed by the manufacturers.



DO your builder friends take the AMERICAN BUILDER?—Better invite them in.

THIS BRUSH



SENT Direct To Your Address

ONLY \$2.45

No. 12 Mix—2 Row Grey Hair for Browning \$2.45
 Above Brush, known as No. 12, is not a bristle brush
PURE BRISTLE BRUSHES Priced Below
 No. 22 Super—2 Row White Bristle \$4.45
 No. 2 Pacer—2 Row White Bristle 5.45
 No. 32 Super—3 Row White Bristle 5.95
 No. 3 Pacer—3 Row White Bristle 6.95
 No. 21 Peggy—3 Row Grey Bristle 6.45
 No. 01 Acme—3 Row White Bristle 8.95
 No. 003 Acme—3 Row Grey Bristle 8.50

A HANDY Book Sent FREE With Every Order — If You Have Not Received Our 1922 Catalog Ask for One — ITS FREE! ADDRESS ALL ORDERS & CORRESPONDENCE AND MAKE ALL PAYMENTS PAYABLE TO 1528 Walnut Street

Goldblatt Tool Co., KANSAS CITY, MO.
 THE LARGEST EXCLUSIVE BUSINESS OF ITS KIND

Goldblatt



TROWELS
 Are The BEST—Why?

Every Good Plasterer Knows the Answer—
 And They Cost You Less!

Price Each Only \$2.25
 Delivered To Your Address

Our Special with a SAW-STEEL Blade Only \$2.99
 OUR EXTRA SPECIAL MADE WITH A
 SAW-STEEL BLADE & CAMEL-BACK HANDLE Only \$2.99
TROWELS COME 10 1/2" - 11" - 11 1/2" - WHEN ORDERING STATE SIZE WANTED

THE ELGIN BRICK CLEANER

Driven either by our magneto equipped gasoline engine or by electric motor

Cleans more bricks — quicker, cheaper, cleaner. Saves the wages of three men.



Used by the largest concerns in the country.

Big reduction in price this season.

Write for circular.

ELGIN GAS MOTOR CO.
 58 River Street, ELGIN, ILL.

Gurney

REFRIGERATORS

THE housewife, purchaser and the apartment house owner each find a direct appeal in Gurney Refrigerators. The compact, yet roomy, end-icing style herewith illustrated is representative of the quality of the complete Gurney line.

Wire shelves heavily tinned are at once light, strong and easily cleaned. They permit a free circulation of cold draughts from the ice chamber. The housewife will delight in their practicability—the purchaser and apartment house owner will recognize the economic advantage of this construction and will be pleased with the workmanship thruout.

End or rear icing doors have come to be indispensable to the busy housekeeper who has no time to clean floors after the iceman. Gurney refrigerators are made with either end or rear icing doors.

We will be pleased to mail you a catalogue of our complete line.

GURNEY REFRIGERATOR CO.

Fond Du Lac, Wisconsin

Permanent Chicago Exhibit 308 N. Michigan Avenue

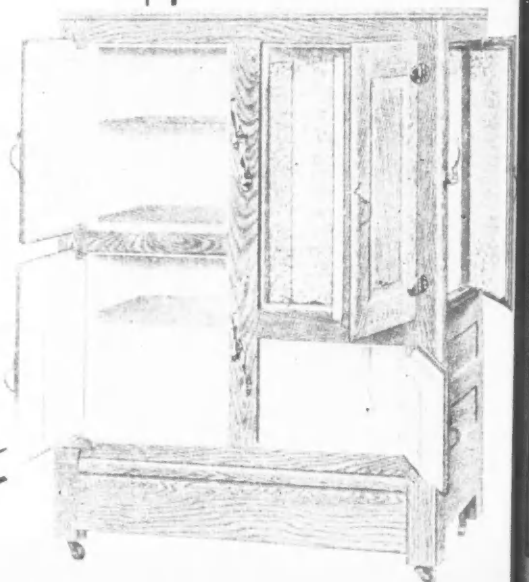



get this catalog

We shall be glad to send you this carefully compiled booklet on request

GOOD, clear pictures illustrate and describe our line of wood, brick and art stone chimney pieces. A complete line of fireplace accessories, chimney dampers, coal chutes, floor and wall tiling, cistern and coal hole covers, ash pit doors, etc.

Liberal Discount to Dealers

WRITE TODAY FOR YOUR COPY OF THIS INTERESTING BOOKLET.

GRAND RAPIDS MARBLE & FIREPLACE CO.
GRAND RAPIDS, MICHIGAN

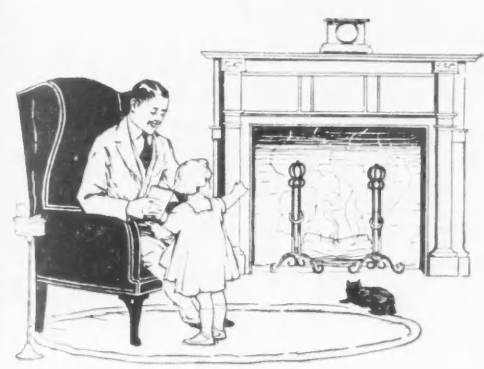

Handsome is the Fireplace That Handsome Does

A HOME OWNER who finds perfect contentment at his fireside never ceases to bless the builder who planned and constructed it to draw properly, to burn cleanly and with a moderate fuel outlay.

The Donley Damper, which not only regulates draft but which forms correctly the throat of the fireplace, is the builder's best guarantee that the fireplace will not discharge smoke in the room and will yield maximum warmth.

Donley Dampers are made with two types of draft control, a key control type and another type controlled by use of a common poker.

With the Donley Damper, use a Donley Ash Dump in the hearth and a Donley Ash-Pit Door below.

Send for printed matter on the correct design and construction of Fireplaces.

The DONLEY DAMPER



DONLEY DAMPERS · PACKAGE RECEIVERS · COAL CHUTES · METER BOXES · GARBAGE RECEIVERS

ASH DUMPS AND FIREPLACE SPECIALTIES *The DONLEY BROTHERS & CO.* BUILDING SPECIALTIES 7400 ETNA RD CLEVELAND METAL COLUMNS AND STRUCTURAL SPECIALTIES

DONLEY DEVICES *Modernize the Home*

NEWS OF THE FIELD

New Wadsworth-Howland Factory

WADSWORTH, HOWLAND & CO., Inc., Boston, Mass., have opened a new factory at 211-219 Forty-seventh Street, Brooklyn, N. Y., where they will manufacture the complete line of Bay State paint and varnish products for that section.



Pittsburgh Builders Offer Scholarship

THE Pittsburgh Builders' Exchange has established a scholarship for \$300.00 at Carnegie Institute of Technology, Pittsburgh, Pa. Under the terms this amount will be available each year during the life of the scholarship to be awarded to meritorious students in the Department of Building Construction, College of Industries.

Awards will be made on the basis of scholastic standing, good character, and evidence of the exceptional promise for success in the building construction industry. The scholarship may be divided at the discretion of the faculty.



Chain Belt Appoints Pittsburgh Manager

THE CHAIN BELT CO., Milwaukee, Wis., has announced the appointment of G. F. Sherratt as manager of the Pittsburgh office in the Union Arcade Building. Mr. Sherratt will be in charge of all the company's chain and engineering business in the Pittsburgh territory and is equipped to render engineering service on power transmitting and material handling problems.

The Ward Equipment Company of Pittsburgh will continue to handle the complete line of Rex Concrete Mixers and Pavers, and the United Equipment Company the Rex Traveling Water Screens.



Annual Meeting of Austin Corporation

THE annual meeting of stockholders and board of directors of the Austin Machinery Corporation was recently held in Richmond, Va., and New York.

The board of directors, consisting of B. A. Linderman, Ralph Crews, Clay Hollister, Samuel McRoberts, C. A. Peckham, John R. Shaw and Hon. C. W. Watson, were elected.

Officers elected were as follows:

B. A. Linderman, president.
John R. Shaw, vice-president.
William Wertz, secretary.
J. R. Van Keppel, treasurer.

The executive committee consists of Samuel McRoberts, Ralph Crews, Hon. C. W. Watson and B. A. Linderman.

The company reports unusual expansion in the sales organization and many additions to its already expansive line of road building, excavating, irrigation and contractors' machinery.



Fire Destroys Shrauger & Johnson Factory

DAMAGE to the extent of \$125,000 was caused by a destructive fire which destroyed the main factory and office building of Shrauger & Johnson, Atlantic, Ia. The

SEND FOR OUR AGENCY PROPOSITION

It's Worth \$5,000 a Year to Many of Our Agents. It's Worth that Much to You, Too

The housing and building situation is more serious now than any time in history. This is the moment of opportunity for the man who wants to get into a business of his own, if ever, and in a field where he makes real money.

The weatherstrip business is an uncrowded field and there are places still where we would like to appoint live agents. Perhaps there's such an opportunity right in your locality.

Write us; you may be just the man who we are looking for and just the big opportunity that has been waiting you.

Practically No Money Required

Unlike most businesses, the weatherstrip agent needs little money to swing it—practically none.

Everything is in favor of the active, energetic man. So write for our co-operative selling plan. You do not obligate yourself in the least.

ALLMETAL WEATHERSTRIP COMPANY

124 West Kinzie St., Chicago

Bostwick

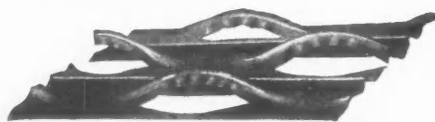

"Truss-Loop" Metal Lath
"Diamond A" Expanded Metal
"Niles" Expanded Metal
"Lock" Expanded Metal
"Truss-V-Rib Re-enforcement

Channel Iron
Corner Bead—Rail
—Standard
—Truss-Wing
Base Bead
Wall Plug
Wall Ties—Y, No. 1, No. 2

Write for prices and full information

The Bostwick Steel Lath Company
NILES, OHIO

Bostwick

TRUSS-LOOP

UNION METAL COLUMNS

Design 240 For Repair and Replacement

THOUSANDS of split and rotted wood columns will be replaced this year with these handsome Union Metal Pressed Steel Columns—"The Ones That Last a Lifetime."

ORDER NOW—WE PAY THE FREIGHT

Your orders for Design 240 Doric will be accepted until June 15, 1922, at the following low prices, with freight prepaid to your nearest railroad station.

District	Diameter Shaft at Base	Height Over All	Net Price Delivered	Item No.
East of Mississippi River and North of Tennessee and North Carolina	10"	Up to 6'	\$12.10	1
	10"	From 6' to 8'	12.90	2
	12"	Up to 6'	15.40	3
	12"	From 6' to 8'	16.40	4

For delivery in Southern States and west of Mississippi River, add to Item 1, \$2.15; Item 2, \$2.35; Item 3, \$2.95; Item 4, \$3.15.

THE UNION METAL MANUFACTURING CO.
CANTON, OHIO

Design 240

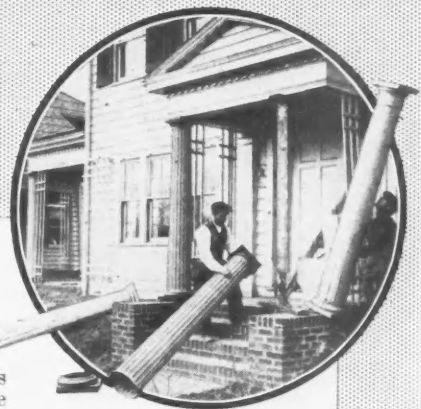

Actual photograph taken in Cleveland, showing rotted and split wood columns, in service only three years, being replaced by Union Metal Pressed Steel Columns. This is a typical experience of thousands of home owners throughout the country.

NINE OTHER DESIGNS—Sizes 5' to 32' high all diameters to 36". Write for Catalog 21.

Get a Parks!

PARKS Planing Mill Special 8 Machines in 1 - Complete Machinery equipment for your woodworking shop -

\$475.00

Built right—Priced right
10 years' Guarantee
10 days' Trial
Write for catalog and
information.

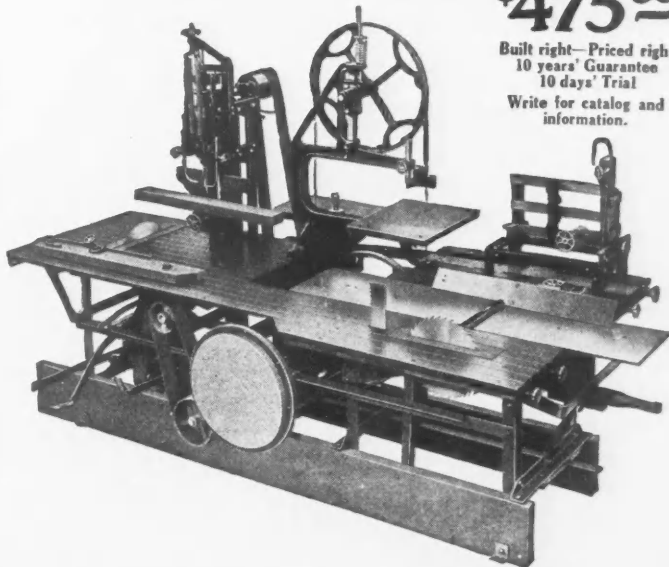

"I never had a job my Parks didn't help me on!" says M. Cooper, Guthrie Center, Iowa.

Your Parks won't stand idle in your shop. You'll quit doing hand-carpentering at a bench. You'll turn out your work on your Parks.

No matter how good a hand-carpenter you are, no matter how fast you work, you'll never be able to beat your Parks. And the best workman you know can't turn out a better job. Get your Parks!

8 machines in one. Always ready to go. Never quits. Double Table Circular Saw, Rip and Crosscut Saw, Swing Cut-Off Saw, 12-in Joints, Tenoner, Band Saw, Upright Hollow Chisel Mortiser and Borer, Reversible Spindle Shaper and Sander.

THE PARKS BALL BEARING MACHINE CO.
Fergus Street and C. H. & D. R. R., Cincinnati, Ohio

Chicago Offices and Show Room - - - - 615 Machinery Hall
Canadian Factory - - - - 200 Notre Dame East, Montreal, Canada
Western Office and Warehouse: 1113 Farnam Street, Omaha, Neb.

WOODWORKING PARKS MACHINES

fire did not damage the other three factories of this company. They are going ahead on full production, day and night shifts.

To aid the concern, the Atlantic Canning Co. turned over a large factory equipped with power and machinery until Shrauger & Johnson can rebuild. Two weeks after the fire their plant was running full force and in spite of the handicap the company is now turning out over 600 windows daily. Plans are already drawn up for a new factory to replace the old one, and it is expected that the new building will be ready by July 1. The company is now in a position to make immediate shipments on orders.



Statement of the Ownership, Management, Circulation, Etc., Required By the Act of Congress of August 24, 1912

of AMERICAN BUILDER, published monthly at Chicago, Ill., for April 1, 1922.
State of Illinois }
County of Cook } ss.

Before me, a Notary Public in and for the State and county aforesaid, personally appeared E. L. Hatfield, who, having been duly sworn according to law, deposes and says that he is the Business Manager of the AMERICAN BUILDER and that the following is, to the best of his knowledge and belief, a true statement of the ownership, management (and if a daily paper, the circulation), etc., of the aforesaid publication for the date shown in the above caption, required by the Act of August 24, 1912, embodied in section 443, Postal Laws and Regulations, printed on the reverse of this form, to wit:

1. That the names and addresses of the publisher, editor, managing editor and business managers are:

Publisher, American Carpenter & Builder Co., Chicago, Ill.; Editor, Wm. A. Radford, Chicago, Ill.; Managing Editor, Bernard L. Johnson, Chicago, Ill.; Business Manager, E. L. Hatfield, Chicago, Ill.

2. That the owners are: (Give names and addresses of individual owners, or, if a corporation, give its name and the

names and addresses of stockholders owning or holding 1 per cent or more of the total amount of stock.) American Carpenter & Builder Co., Chicago, Ill.; Wm. A. Radford, Chicago, Ill.; H. M. Radford, Chicago, Ill.; R. D. Radford, Chicago, Ill.; Wm. A. Radford, Jr., Chicago, Ill.; E. L. Hatfield, Chicago, Ill.; G. W. Ashby, Berwyn, Ill.

3. That the known bondholders, mortgagees, and other security holders owning or holding 1 per cent or more of total amount of bonds, mortgages, or other securities are: (If there are none, so state.) None.

4. That the two paragraphs next above, giving the names of the owners, stockholders, and security holders, if any, contain not only the list of stockholders and security holders as they appear upon the books of the company but also, in cases where the stockholder or security holder appears upon the books of the company as trustee or in any other fiduciary relation, the name of the person or corporation for whom such trustee is acting, is given; also that the said two paragraphs contain statements embracing affiant's full knowledge and belief as to the circumstances and conditions under which stockholders and security holders who do not appear upon the books of the company as trustees, hold stock and securities in a capacity other than that of a bona fide owner; and this affiant has no reason to believe that any other person, association, or corporation has any interest direct or indirect in the said stocks, bonds, or other securities than as so stated by him.

5. That the average number of copies of each issue of the publication sold or distributed, through the mails or otherwise to be paid subscribers during the six months preceding the date shown above is _____. (This information is required from daily publications only.)

Sworn to and subscribed before me this 31st day of March 1922.

[Seal] ANDREW JOHN NAUMANN.
(My commission expires Oct. 23, 1925.)



Y EARLY 98 per cent of the lumber, all the shingles and all the lath imported into the United States in 1919 came from Canada; in 1920, 97.8 per cent of the lumber and more than 99 per cent of the shingles and lath were imported from Canada.

WOOD-REINFORCED

THE IDEAL PLASTERING BASE

**Prevents
Cracking
Checking
Staining
of Walls**

WIRE-REINFORCED

THE IDEAL PLASTERING BASE

**Fire-Retardant
Sound-Deadening
Rust-Proof
Damp-Proof
Insulates**

In this 18-apartment building for the W. J. Mueller Company, Chicago, B. Bruns, Architect, E-COD FABRIC is specified for all interior plastering

E-COD FABRIC in the Apartment

There are many advantages in the use of **E-COD FABRIC** in the modern apartment. One of the strong points is its sound-deadening quality. The two thicknesses of heavy asphalted felt form a double barrier against transmission of sound through partitions.

E-COD FABRIC is fire-retardant, another essential not only in apartment but in all building. Also, it insulates perfectly against heat and cold.

E-COD FABRIC absolutely eliminates checking, staining and crack-

ing of plaster. Interiors plastered on **E-COD FABRIC** may be decorated or papered at once without fear of future damage.

It is low in first cost and in every operation of plastering. It saves 40% to 60% of the plaster which goes to form the key on any ordinary open-mesh lath. It saves time in application and is the most satisfactory plastering base for all exterior and interior work. Get samples. Submit them to every test. They will make good for you and for your clients. Write today to

Conway Building
CHICAGO

M. J. MACADAMS CORPORATION

101 Park Avenue
NEW YORK

WHEN WRITING ADVERTISERS PLEASE MENTION THE AMERICAN BUILDER

You Draw The Plans and You'll Get The Job

\$5⁰⁰
Brings You

The Outfit Complete
A YEAR TO PAY

Thousands Have Won Success This Way

Here's a proven plan to increase your business, profits and reputation. Furnish the plans and you get the job, and at a fair price. Others do it, why not you? You know plans. With the right instructions and material you can draw them as well as any man. You get everything at once—no long drawn out correspondence course. And the price is astonishingly low. Let this advertisement mean a new start and a greater prosperity for you.

A Practical Outfit

Our proposition is so fair, straightforward and easy that you cannot refuse to investigate it in justice to yourself. Everything you need is in this outfit. Don't confuse this fine, practical drawing outfit with the small and cheap students' outfits often advertised. It is the most useful, simple, practical outfit for contractors and builders ever offered.

Begin Work At Once

The two special instruction books, "How to Draw Plans" by Dale and the Kidder-Nolan "Builders' and Architects' Handbook", included free, tell you how, simply and plainly, step by step. Enables you to begin at once to make plans and drawings and thereby to increase your business, reputation and income.

Sent On Free Trial

Let us send you this complete outfit at our risk. Try it for ten days. Note the completeness of the outfit, the quality and finish of every article. If you are not more than pleased with the outfit after ten days trial, return it and your \$5.00 initial payment will be refunded. If you decide to keep the outfit, pay it on Aloe's Easy Rental Purchase Plan.

Write For Literature

Mail the coupon to-day—it will bring you full particulars of this extraordinary offer—tell you about the outfit in detail—explain our easy payment plan—and show you how you can easily increase your business and profits. Be wide-awake. Act—Investigate—Write to-day.

A. S. Aloe Co.
616 Olive St.,
St. Louis, Mo.

Without obligation, send me full particulars about your High-grade Draftman's Outfit.

MAIL COUPON TODAY

Name.....

Address.....

FREE TRIAL

Outfit consists of

- 1 Complete Set of Drawing Instruments.
- 1 Portable Steel Table with Drawing Board.
- 1 Book: "How to Draw Plans".
- 1 Kidder-Nolan "Builders' Guide".
- 1 Ebony T-Square.
- 1 30x60 Celluloid 8 inch Triangle.
- 1 60 6-inch Triangle.
- 1 Celluloid Curve.
- 1 12-inch Triangular Scale.
- 1 Roll 36-in. Tracing Paper.
- 1 Roll 36-in. Detail Paper.
- 1 Four-foot Folding Rule.
- 1 Brass Protractor.
- 1 Doz. Gillott Special Pens.
- 1 Doz. Drawing Pencils.
- 1 Doz. Thumb Tacks.
- 1 Pencil Eraser.
- 1 Ink Eraser.
- 1 Pencil Pointer.
- 1 Bottle Red Ink.
- 1 Bottle Black Ink.
- 1 Gillott Pen Holder.
- 1 Piece Artgum.
- 1 Dixon's White Pencil.

A. S. ALOE CO. 616 Olive St. St. Louis, Mo.

INTERNATIONAL SERVICE

COVERS DESIGNING, ESTIMATING, MANUFACTURING AND PROMPT DELIVERIES OF BUILDING MATERIALS REQUIRED FOR

INDUSTRIAL BUILDINGS - GARAGES - MODERN STORE FRONTS

- COAL TIPPLES
- HIGHWAY BRIDGES
- FIRE ESCAPES
- IRON STAIRS
- PIPE RAILING
- STEEL WINDOWS
- COAL CHUTES
- ELEVATORS
- STEEL CEILING

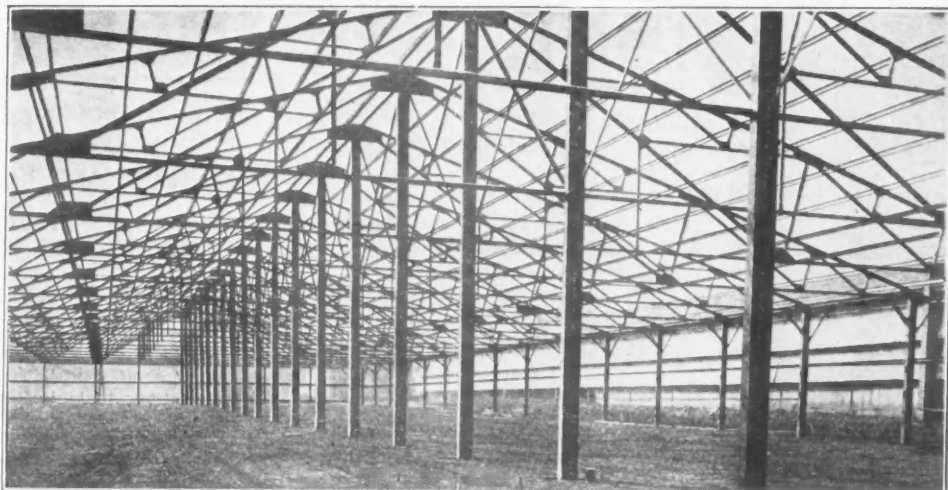

- WAREHOUSES
- STEEL LUMBER
- METAL LATH
- REINFORCING BARS
- SKYLIGHTS
- GALVANIZED IRON CORNICES
- VENTILATORS
- AREA GRATES
- MILLWORK
- MARQUISES

FIRE PROOF WAREHOUSE DESIGNED, FABRICATED AND ERECTED BY THE

INTERNATIONAL STEEL & IRON COMPANY

Address Department 18, EVANSVILLE, INDIANA

OPERATING: STEEL PLANTS WOODWORKING PLANTS SHEET METAL PLANTS
SEND US YOUR INQUIRIES—DESIGNS AND ESTIMATES FREE

WRITE FOR "GARAGE ILLUSTRATIONS" SHOWING AT LEAST 50 MODERN BUILDINGS DESIGNED BY US

Catalogs, Bulletins and Books Received

"Keystona Flat Finish" is the subject of a booklet distributed by the Keystone Varnish Co., Brooklyn, N. Y. It describes and illustrates in colors the application of this finish which is applied like paint, looks like wall paper, and can be washed. A group of prominent buildings in which it has been used is also shown.

"The Home Painting Manual" is a complete handbook on painting problems published by the Sherwood-Williams Co., Cleveland, O. It treats of color schemes, use of paint, estimating costs, individual treatment in exterior painting, interior finishing on woodwork and furniture, treatment of floors, color harmony, wall and ceiling treatment, stencils, and miscellaneous painting. It contains a number of color illustrations of exteriors and interiors and sells at 50c a copy.

"Residence Lighting," "Church Lighting," "Lighting of Public Buildings," and the "Edison Mazda Lamp for Motion Picture Projection" are the titles of a new set of bulletins from the Edison Lamp Works, General Electric Co., Harrison, N. J. They are profusely illustrated with views and diagrams pertaining to the subjects treated.

"The Forest Products Laboratory," a handsome leather-bound volume covering in detail the decennial record of that institution from 1910 to 1920. It also contains the program of the celebration held at Madison, Wis., last year, in which the leading wood-using interests of the country took part. Copies have been sent to various associations, concerns, and schools. Other copies are for sale at \$1.75 each.

"Invisible joint" metal ceilings and side walls are described and illustrated in a booklet now being distributed by the Milwaukee Corrugating Co., Milwaukee, Wis., thru their dealers. This booklet shows representative designs and artistic combinations which have been worked out in metal, also complete directions for applying metal walls and ceilings.



SCHILLI SCREEN STRETCHER

Saves its cost on first job. Clamps to bench. Stretches all sizes in screen wire, up to 36 in., by simple change.

Weight 15 lbs. Price \$7.00. Shipped direct.

SCHILLI MFG. COMPANY
5420 Kings Highway Bl.
ST. LOUIS, MO.

If

YOU DO NOT FIND WHAT YOU WANT

in the AMERICAN BUILDER, write us and we will try to get it for you.



HAVE A MECHANICS' LINE REEL

KEEP YOUR LINE FREE FROM KINKS AND KNOTS

If your dealer cannot supply you send his name and 25 cents for this

LINE SAVER AND TIME SAVER

DEALERS—Write for Prices

S. A. BROCKWAY, Columbus, Neb.



BOMMER

SPRING HINGES

Standard for over 45 years, and steadily improved, retaining superiority over all others. In universal demand. Easiest to apply.

BOMMER SPRING HINGE COMPANY **MANUFACTURERS, BROOKLYN, N. Y.**

Cleans 16,000 Bricks in 8 Hour Day

Mortar From All Sides and Ends Cleaned Automatically—Fed By One Man.

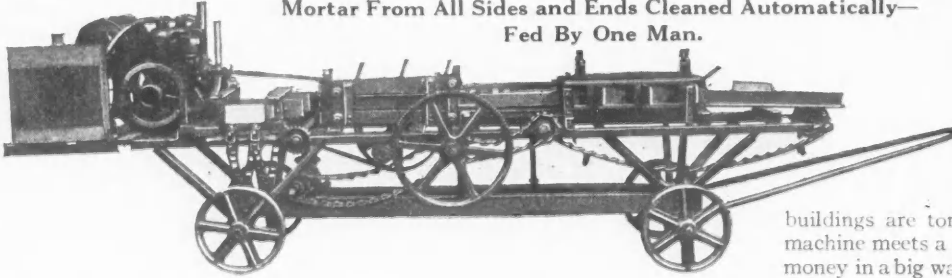

Used building brick covered with mortar are fed into one end of this machine and they come out at the other end cleaned ready to relay. Does the work of more than 20 men. One man can operate it. Where buildings are torn down or burn down this machine meets a great need. Saves time and money in a big way. Write today for Bulletin No. 25 and prices. Costs very little to clean bricks with this machine.

MAROA MANUFACTURING CO., Dept. A, Maroa, Ill., U. S. A.