

# AMERICAN BUILDER

Including "BUILDING DEVELOPER" and "HOME BUILDING"

A SIMMONS-BOARDMAN PUBLICATION

Vol. 48.

CONTENTS FOR DECEMBER, 1929

No. 3.

COPYRIGHT, 1929, BY AMERICAN BUILDER PUBLISHING CORPORATION

|  |       |   |          |
|--|-------|---|----------|
| Editorials . . . . .   | 57-59 | Model Homes in Cleveland . . . . .  | 89-95    |
| The Stock Market and the Building Business—Build Now and Avert Slump.  |       | By H. P. Boynton—Successful Campaign of the Cleveland Better Homes Association—Six Model Homes Illustrated.   |          |
| Optimistic Outlook for Sound Construction Projects . . . . .   | 60    | Home Plan Suggestions . . . . .   | 90-97    |
| An Interview with Nicholas Roberts, President S. W. Straus & Co., by Frank Thayer.                                       |       | A Colonial in Brick Veneer.<br>Shingled Walls Are Pleasing.<br>Frame and Half-Timbered Stucco.<br>A Handsome Brick Residence.<br>Done in Dutch Colonial Style.<br>Colonial Dignity in Every Line.<br>Distinctive and Appealing.<br>A Charming Cottage Home. |          |
| Hoover Enlists Builders . . . . .  | 61    | AMERICAN BUILDER All-Feature Home .98-102   |          |
| Conference at White House to Stimulate Business.   |       | Complete Working Plans to One-eighth Inch Scale for a Model Brick Bungalow.   |          |
| "Modernesque" . . . . .  | 62-65 | Where Stores and Apartments Are Combined . . . . .  | 103      |
| Unique Home, Built by McWilliams and Meloney Outside of Philadelphia, Demonstrates the Latest in Modernism.              |       | Rissman and Hirschfeld, Architects.   |          |
| Mortgages Yielding Higher . . . . .  | 70    | Framing the Gambrel Roof . . . . .  | 104-105  |
| Survey Shows Superior Earning Power Over Stocks and Bonds.   |       | Continuing Our Course in Roof Framing Simplified, by John T. Neufeld.   |          |
| Waste Not High Wages Makes Building Costly . . . . .   | 71    | Questions and Answers . . . . .   | 106-108  |
| By Morton C. Tuttle, President Morton C. Tuttle Company, Builders.   |       | The October Questions Answered and Eight Other Important Questions Asked.   |          |
| Where Quality and Beauty Meet . . . . .  | 72-76 | How Dan Does It . . . . .   | 114      |
| The Story of the Development of Gladstone Manor, by W. Percival Johnson.   |       | A Handy Door Clamp.<br>Another Way to Cut Bridging.<br>Another Better Stair Idea.   |          |
| Public Garages . . . . .   | 77-81 | What's New Department . . . . .   | 118, 120 |
| By Tom Wilder—The Fifth of a Series Describing Important Special Classes of Buildings.                                   |       | News of the Field . . . . .   | 122      |
| A Sound Proof Studio Apartment . . . . .   | 82-83 | Book Reviews . . . . .  | 126      |
| The Sherman Square Studios, West 73rd Street, New York City; Tillion & Tillion, Architects—Insulation Methods Described. |       | ADVERTISERS' INDEX . . . . .  | 163-165  |
| The Conveniently Equipped Kitchen Helps Builders Sell . . . . .  | 84-88 |   |          |
| A Merchandising Article for Speculative and Merchant Builders.   |       |   |          |

Published on the first day of each month by the American Builder Publishing Corporation. *President*, Edward A. Simmons; *Vice-Presidents*, Henry Lee and Samuel O. Dunn; *Treasurer*, John T. DeMott; *Secretary*, Elmer T. Howson; *Editors*, Bernard L. Johnson and Charles G. Pekar; *Associate Editors*, P. W. Hanna, E. B. Quigley, L. E. Arent; *Business Manager*, Robert H. Morris; *Advertising Staff*, Delbert W. Smith, C. R. W. Edgcombe, L. H. Reich, O. H. Sutter, Cecil W. Blashill, R. E. Clement, Homer Beach.

**Publication Office:**

**Bankers Building, 105 W. Adams St., Chicago**

Telephone: Randolph 0794

**Branch Offices:**

New York—30 Church St.  
Cleveland—Terminal Tower.

Washington—17th and H Sts., N.W.  
San Francisco—215 Market St.

**Other Simmons-Boardman Publications Are:**

|  |                             |
|--|-----------------------------|
| Railway Age                                    | Railway Mechanical Engineer |
| Railway Signaling                              | The Boilermaker             |
| Railway Engineering and Maintenance            | Airway Age                  |
| Railway Electrical Engineer                    | House Furnishing Review     |
| Marine Engineering and Shipping Age            |                             |
| Railway Engineering and Maintenance Cyclopedia |                             |
| Car Builder's Cyclopedia                       | Locomotive Cyclopedia       |

Entered as second-class matter July 1, 1905, at the postoffice at Chicago, Ill., under the Act of March 3, 1879. Additional entry as second-class matter at Binghamton, N. Y.

**SUBSCRIPTION RATES**—One year, United States, Canada, Mexico and U. S. Possessions, \$2.00; six months, \$1.00; single copy, 35 cents. Foreign countries, \$4.00.

**ADVERTISING RATES**—Furnished on application. Advertising forms close on the 10th of the month preceding date of publication.

MEMBER OF THE AUDIT BUREAU OF CIRCULATIONS  
AND OF THE ASSOCIATED BUSINESS PAPERS

# AMERICAN BUILDER

Including "BUILDING DEVELOPER" and "HOME BUILDING"

A SIMMONS-BOARDMAN PUBLICATION

Vol. 48.

CONTENTS FOR DECEMBER, 1929

No. 3.

COPYRIGHT, 1929, BY AMERICAN BUILDER PUBLISHING CORPORATION

|  |       |   |          |
|--|-------|---|----------|
| Editorials . . . . .   | 57-59 | Model Homes in Cleveland . . . . .  | 89-95    |
| The Stock Market and the Building Business—Build Now and Avert Slump.  |       | By H. P. Boynton—Successful Campaign of the Cleveland Better Homes Association—Six Model Homes Illustrated.   |          |
| Optimistic Outlook for Sound Construction Projects . . . . .   | 60    | Home Plan Suggestions . . . . .   | 90-97    |
| An Interview with Nicholas Roberts, President S. W. Straus & Co., by Frank Thayer.                                       |       | A Colonial in Brick Veneer.<br>Shingled Walls Are Pleasing.<br>Frame and Half-Timbered Stucco.<br>A Handsome Brick Residence.<br>Done in Dutch Colonial Style.<br>Colonial Dignity in Every Line.<br>Distinctive and Appealing.<br>A Charming Cottage Home. |          |
| Hoover Enlists Builders . . . . .  | 61    | AMERICAN BUILDER All-Feature Home .98-102   |          |
| Conference at White House to Stimulate Business.   |       | Complete Working Plans to One-eighth Inch Scale for a Model Brick Bungalow.   |          |
| "Modernesque" . . . . .  | 62-65 | Where Stores and Apartments Are Combined . . . . .  | 103      |
| Unique Home, Built by McWilliams and Meloney Outside of Philadelphia, Demonstrates the Latest in Modernism.              |       | Rissman and Hirschfeld, Architects.   |          |
| Mortgages Yielding Higher . . . . .  | 70    | Framing the Gambrel Roof . . . . .  | 104-105  |
| Survey Shows Superior Earning Power Over Stocks and Bonds.   |       | Continuing Our Course in Roof Framing Simplified, by John T. Neufeld.   |          |
| Waste Not High Wages Makes Building Costly . . . . .   | 71    | Questions and Answers . . . . .   | 106-108  |
| By Morton C. Tuttle, President Morton C. Tuttle Company, Builders.   |       | The October Questions Answered and Eight Other Important Questions Asked.   |          |
| Where Quality and Beauty Meet . . . . .  | 72-76 | How Dan Does It . . . . .   | 114      |
| The Story of the Development of Gladstone Manor, by W. Percival Johnson.   |       | A Handy Door Clamp.<br>Another Way to Cut Bridging.<br>Another Better Stair Idea.   |          |
| Public Garages . . . . .   | 77-81 | What's New Department . . . . .   | 118, 120 |
| By Tom Wilder—The Fifth of a Series Describing Important Special Classes of Buildings.                                   |       | News of the Field . . . . .   | 122      |
| A Sound Proof Studio Apartment . . . . .   | 82-83 | Book Reviews . . . . .  | 126      |
| The Sherman Square Studios, West 73rd Street, New York City; Tillion & Tillion, Architects—Insulation Methods Described. |       | ADVERTISERS' INDEX . . . . .  | 163-165  |
| The Conveniently Equipped Kitchen Helps Builders Sell . . . . .  | 84-88 |   |          |
| A Merchandising Article for Speculative and Merchant Builders.   |       |   |          |

Published on the first day of each month by the American Builder Publishing Corporation. *President*, Edward A. Simmons; *Vice-Presidents*, Henry Lee and Samuel O. Dunn; *Treasurer*, John T. DeMott; *Secretary*, Elmer T. Howson; *Editors*, Bernard L. Johnson and Charles G. Pekar; *Associate Editors*, P. W. Hanna, E. B. Quigley, L. E. Arent; *Business Manager*, Robert H. Morris; *Advertising Staff*, Delbert W. Smith, C. R. W. Edgcumbe, L. H. Reich, O. H. Sutter, Cecil W. Blashill, R. E. Clement, Homer Beach.

**Publication Office:**  
**Bankers Building, 105 W. Adams St., Chicago**

Telephone: Randolph 0794

**Branch Offices:**

New York—30 Church St.  
Cleveland—Terminal Tower.

Washington—17th and H Sts., N.W.  
San Francisco—215 Market St.

Other Simmons-Boardman Publications Are:

- |  |                             |
|--|-----------------------------|
| Railway Age                                    | Railway Mechanical Engineer |
| Railway Signaling                              | The Boilermaker             |
| Railway Engineering and Maintenance            | Airway Age                  |
| Railway Electrical Engineer                    | House Furnishing Review     |
| Marine Engineering and Shipping Age            |                             |
| Railway Engineering and Maintenance Cyclopedia |                             |
| Car Builder's Cyclopedia                       | Locomotive Cyclopedia       |

Entered as second-class matter July 1, 1905, at the postoffice at Chicago, Ill., under the Act of March 3, 1879. Additional entry as second-class matter at Binghamton, N. Y.

SUBSCRIPTION RATES—One year, United States, Canada, Mexico and U. S. Possessions, \$2.00; six months, \$1.00; single copy, 35 cents. Foreign countries, \$4.00.

ADVERTISING RATES—Furnished on application. Advertising forms close on the 10th of the month preceding date of publication.

MEMBER OF THE AUDIT BUREAU OF CIRCULATIONS AND OF THE ASSOCIATED BUSINESS PAPERS



# AMERICAN BUILDER

Including "Building Developer" and "Home Building"

BERNARD L. JOHNSON and CHARLES G. PEKER, *Editors*



## The Stock Market and the Building Business

PROBABLY no question has been more discussed recently than the probable effects of the recent violent decline in stock market prices upon general business in the United States.

One point upon which all economic and business authorities are agreed is that it will help the building industry.

It is significant that President Hoover, who has taken the lead in efforts to maintain the prosperity of the country, has placed the greatest emphasis upon the probability and the importance of an increase of construction activities by both private interests and the national government as a means of maintaining general employment and the national economic welfare. The building industry is second only to agriculture in the annual volume of expenditures made for carrying it on and in the amount of employment afforded by it. Reported contracts for building construction during the four years ending with 1928 amounted to \$7,000,000,000 annually; but these reports do not include building in smaller cities and on the farms which unquestionably increases the total to more than \$8,000,000,000 annually. Of this expenditure about 62 per cent, or \$4,960,000,000, is made directly for labor, and about 38 per cent, or \$3,040,000,000, for materials. Indirectly, practically the entire expenditure is made for labor, since, of course, the cost of providing building materials—lumber, brick, steel, cement, and all other things—is, in the last analysis, virtually all incurred in employing labor. Naturally, therefore, President Hoover and other economic and business leaders who are endeavoring to maintain prosperity turn first to this great and peculiarly essential industry. Building materials are of innumerable kinds and come from every part of the country, and therefore whatever stimulates the building industry will directly and indirectly stimulate every other kind of industry.

It is unanimously agreed by economists and business leaders that the great "bull" stock market had an adverse effect upon construction activities. The enormous amount of speculation in corporation stocks that developed, and the unprecedented heights to which prices

of stocks advanced, tied up a vast amount of capital in loans secured directly from brokers and indirectly from the banks and other sources. The tying up of this vast amount of capital caused a large increase in rates of interest. This increased the cost of raising capital for construction work of all kinds, and was largely, if not mainly, responsible for the decline in construction work that occurred in 1929.

What, then, will probably be the effect of the decline in stock market prices? Temporarily it may be harmful to general business. Many people have lost not only large amounts of "paper profits" but, also, money and property. But there is general agreement among economists and business leaders that the adverse effects upon general business will be only temporary. The decline has not destroyed any of the country's capital. Those who have had to sell stocks at lower prices than they paid for them are worse off than they were a short time ago, but those who recently have bought stocks at low prices are better off than they were. The fundamental economic conditions of the country are sound. It has just as much property, as much population and as much productive capacity as it had on September 3, when the stock prices were the highest in history.

Furthermore, and of most direct importance to the construction industry, there has been already a decline of about \$3,500,000,000 in the amount of capital tied up in stock market speculation. This capital has flowed from the offices of the brokers into the banks. It is seeking and must seek investment. Its transfer from brokers' offices to the banks already has reduced interest rates. Consequently money can now be borrowed at lower interest rates for building construction than has been possible for a long time.

The recent great stock market speculation probably hurt the building industry more than any other, and its collapse, after its temporary effects have passed, should have a more beneficial and stimulating effect upon the building industry than upon any other.

# a PENBERTHY PUMP

*will help you Remove this sign*

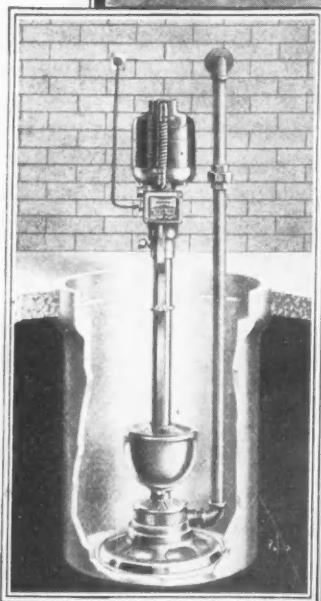
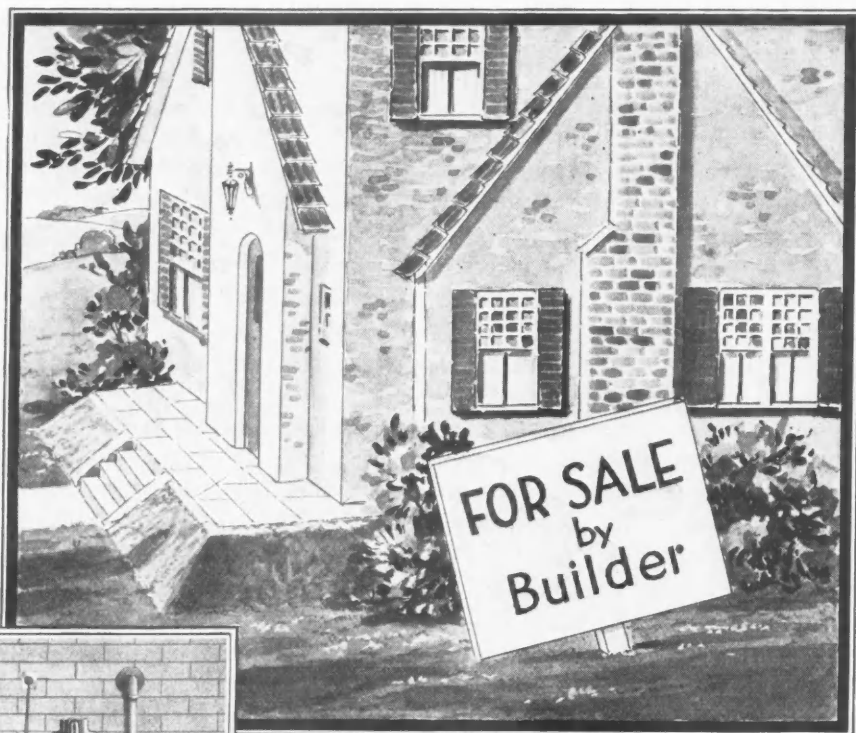

Penberthy Automatic  
Electric Sump Pump

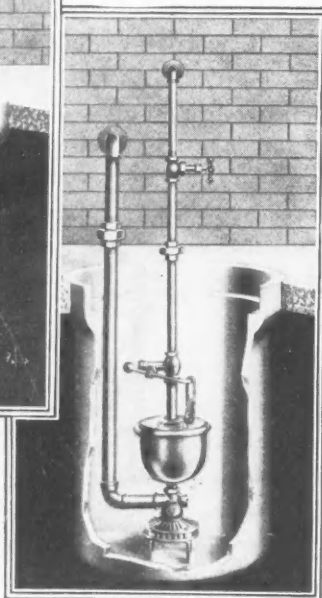

Penberthy Automatic  
Cellar Drainer  
(Water Operated)

**A** WET basement and a "For Sale" sign are often inseparable.

When you assure a dry basement, it becomes easier to remove the sign and get the place under contract.

The least expensive and most effective way of assuring a dry basement below sewer level—and where sewerage facilities are not available—is by installing a Penberthy Pump. Both the electric and hydraulic units are fully automatic and will give the buyer no trouble or concern.

Your plumbing contractor can promptly supply Penberthy Pumps. There is a size to meet every condition.

**PENBERTHY INJECTOR CO., DETROIT**

Established  
in 1886



Canadian Plant  
Windsor, Ont.

## PENBERTHY PUMPS

**PREVENT FLOODED BASEMENTS**

## Build Now and Avert Slump

EVERY thoughtful man whose interests will be adversely affected by bad times during 1930 should consider very seriously the part in averting a possible slump he can play by going ahead now, or in the near future with any form of needed construction.

Men responsible in their communities or in position to give advice, regionally or nationally, should sift the possibilities of a slump, and inevitably they will come to the conclusion that if leaders of industry can be induced to go ahead speedily with contemplated building programs; if prospective home builders can be induced to build now; if faith in the future expressed in this manner is executed, the effects of any slump will be greatly diminished, if indeed any slump could happen.

There is, following the recent stock liquidation, a reasonable doubt in the minds of many as to the actual impairment of buying power especially of commodities above the actual necessity class.

Many feel that the millions of those who have lost more or less heavily will from necessity or from purely mental reaction refrain from purchasing freely and that this in turn will contract the activities of such industries as the automobile and radio, and that this in turn will throw men out of work thereby creating an ever broadening wave of inaction.

Whether we ourselves subscribe to this attitude or not, we all appreciate that there is more or less of this thought prevalent, and we all know that business even though it is now on a sound basis can be affected by a state of mind.

If the mind of the public molds itself into pessimism, most any kind of a slump is not impossible.

What, then, is the bulwark against such possibility? Surely the bulwark is the instituting of some sort of money and man power absorbing activity which will immediately take up the first slack which may be caused by luxury industries feeling the pinch which comes from lessened buying.

If such counter activity can be set in motion soon enough and in great enough proportions, we can as a nation absolutely inoculate ourselves from any very disastrous consequences.

The first start of activity out of a major depression is practically always construction of one form or another.

Why, then, with business conditions admittedly sound, with no surplus of goods on shelves waiting to be dumped, with no reason ahead for a slump except a readjustment of buying power caused by losses to millions which must have resulted in the same dollar value of gain to someone else, can we not put the mighty force of the second largest industry of the United States in number of men employed into full action and not risk any slump?

This is a big order. It is also one of the biggest opportunities for every single contractor in the United States to go out and drum up legitimate business and at the same time be performing a most important function.

Of course, this order is not restricted to the construction industry in the matter of energizing business—of speeding up activity. You will do well to bring the leaders of the community to thinking along the lines of urging early action on building.

Very happily so far as the possibility of insuring against the growth of a slump through construction activity is concerned, the present basis for building is extremely favorable to the public. The present misfortune of the construction industry which is a condition of over competition resulting in slashing everywhere of prices, insures that construction costs are thoroughly eco-

nomical. There is no inflation of construction costs staring us in the face.

Any contractor or builder knows full well that construction costs are on a rock bottom basis. Building to prevent a slump would be a much more favorable procedure for the buying public than waiting and building in these days when the slump had worn itself out and prices and costs in all industries would tend to turn upward.

Apparently there is everything to gain and nothing to lose by sounding a clarion call for speedy acceleration of construction activity. The builder should not delay serious consideration of the most effective way for him to take legitimate advantage of this opportunity to build business and help everyone by so doing.

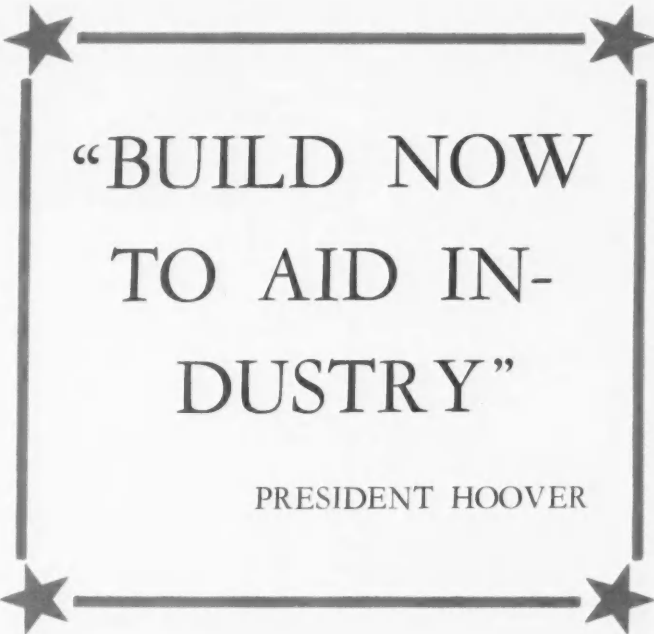

“BUILD NOW  
TO AID IN-  
DUSTRY”

PRESIDENT HOOVER

*As a result of the series of conferences with industrial leaders called by President Hoover, encouraging plans are announced for increased expenditures and activity in Federal construction, railway improvements, public works and general building.*



# Favorable Outlook for Sound Construction Projects

*Based on Interview with Nicholas Roberts, President, S. W. Straus & Co.*

By FRANK THAYER

**W**ILL stock market deflation immediately stimulate building construction? The answer to this question must be predicated upon the ease of financing such construction. An analysis of the situation holds a cautious but optimistic note for the industry.

Real estate brokers apparently are almost universal in their opinion that the heavy liquidation in securities will stimulate the real estate market, stating further that more money will now be available for real estate operations and that rates will be eased considerably.

It is well enough to state that the real estate market and building construction will be immediately affected; back of the situation, however, there remains numerous underlying causes and economic situations which may or may not substantiate the opinions already so quickly expressed. It must be admitted that real estate as well as business generally moves in cycles; the periods of improvement and prosperity do not come with great suddenness, but rather in a gradual movement.

Following the stock market deflation, construction interests naturally think of building improvements, new projects and homes which recently they have had difficulty in financing. Provided that these are sound projects and that there are available funds to carry part of the financing load, it is safe to presume that mortgage money will be available; this is equally true for the erection of small homes or skyscrapers, although such mortgage money will likely be unavailable except as borrowers have sufficient funds to carry a substantial part of the financing load.

In the case of prospective small home owners, funds may not readily be available if these prospective home owners do not have funds to buy sites without incumbrance.

The large financing companies and investment bankers who have specialized in financing large building construction projects, such as hotels, apartment houses and office buildings apparently will proceed with due caution.

From indications, money for large building projects will be available on a most conservative basis. The number of large houses specializing in building con-



**NICHOLAS ROBERTS**  
President S. W. Straus & Co.

struction financing has decreased in the last two or three years; some of these houses, which are now out of business, or are extremely inactive, were formerly liberal in making loans and to a degree the more conservative investment bankers had to meet such competition, with the result that the discount for financing a couple of years ago was likely less than today.

With call money at five or six per cent, it might appear that mortgage money would be easy and readily available. On the contrary, lenders are going to be cautious and moreover are going to have numerous opportunities to lend their funds. Business enterprises that have held up expansion because of recent high money rates, are now going to be in the market for funds. Foreign countries will seek additional finance and American municipalities which have had difficulty in borrowing in early 1929 will also need funds for necessary municipal improvements.

This summary of present financial conditions may seem too cautious, but the attempt has been to give a fairly accurate picture of the underlying situation.

From an optimistic angle it must be remembered that twelve to eighteen months ago business generally was on a sound basis, with the exception of inflation in the stock market, and to some degree in building construction. As 1929 opened, the stock market inflation continued and building construction gradually decreased. At this time inflation is well out of security values and building is on a sound basis.

There is little doubt that the tendency is favorable to building construction, but to say that immediate building activity would result is merely to overstate the situation.

The view of Nicholas Roberts, president of S. W. Straus Co., substantiates the view that the trend in financing building construction will be upward, but

*(Continued to page 116)*



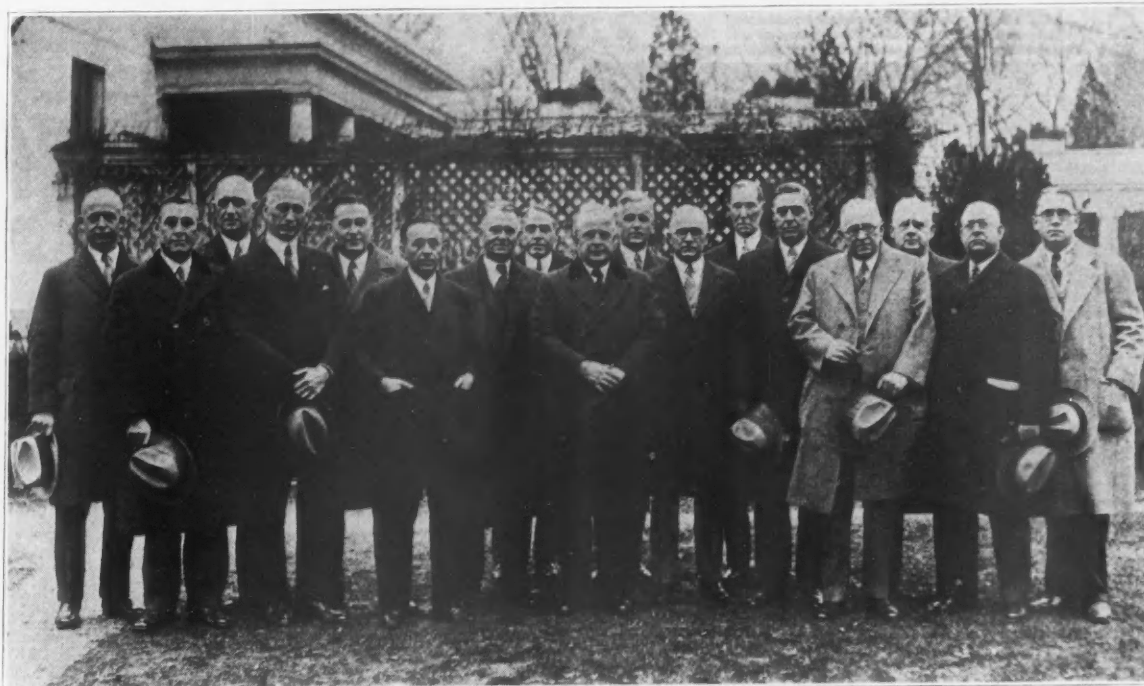

# Hoover Enlists Builders

*Construction Industry Leaders Pledge Support to President's Prosperity Drive*

By H. F. LANE

*Washington Editor, American Builder*

**A**N estimate that \$2,000,000,000 will be expended in 1930 for home modernizing was given to President Hoover during his conference with representatives of the building industry on November 22.

This was one of the important conferences called by the President the week of November 23 for the purpose of considering voluntary and co-operative action between various lines of industry and between business and government agencies in aid of business stabilization and the preservation of the recent high level of general business activity. One of the first results expected is the formation of a business council for continuing study of business conditions. In announcing his intention of holding such conferences, President Hoover said that any lack of confidence in the economic future or the basic strength of business in the United States is foolish; but he pointed out that one of the results of the speculative period "has been the diversion of capital into the security market, with consequent lagging of the construction work of the country" and that the postponement of construction work during the past months "provides a substantial reserve for prompt

expanded action. The next practical step," he added, "is the organizing and co-ordinating of a forward movement of business through the revival of construction activities, the stimulation of exports and other legitimate business expansion." The President has been seeking to deal with the psychological situation resulting from the market break and to inspire a renewed confidence in the face of fears that it might cause a tendency to sit back and see what happens which might spread to a period of depression and unemployment.

The first of the series of conferences was held on November 19 with a group of railway executives, who assured the President of their determination not only to continue, but, if possible, to expand their programs of capital expenditures for construction and betterments. On the same day the advisory council of the Federal Reserve Board, at another conference, reported that business and banking throughout their districts were in sound condition and that the prospects were that money would be available at lower rates. On November 21 there was a similar conference with 22 of the most prominent indus-

*(Continued to page 110)*

## *Above: Construction Industry Leaders at White House Conference, November 22*

**Left to Right:** F. W. Reimers, President Southern Pine Association, Hammond, La.; D. T. Riffle, President National Building Trades Employers' Association, Pittsburgh, Pa.; Samuel Eckels, President Association of State Highway Officials, Harrisburgh, Pa.; Frederick J. Reimer, President American Road Builders' Association, Orange, N. J.; C. M. Upham, Managing Director American Road Builders' Association; A. Trieschmann, President Home Modernizing Bureau, Chicago; A. M. Lewin, President National Retail Lumber Dealers' Association, Cincinnati, Ohio; Sam Hotchkiss, President National Association of Builders' Exchanges, St. Joseph, Mo.; Secretary of Labor James J. Davis; Wilson Compton, Secretary-Manager National Lumber Manufacturers' Association, Washington, D. C.; Arthur W. Berresford, President American Engineering Council, Washington, D. C.; E. L. Carpenter, President National Lumber Manufacturers' Association, Minneapolis; T. T. Flagler, President Associated General Contractors, Atlanta, Ga.; D. A. Garber, General Manager Associated General Contractors, Washington, D. C.; W. M. Wood, President American Institute of Steel Construction, Decatur, Ill.; Frank H. Smith, President Portland Cement Association, Chicago.

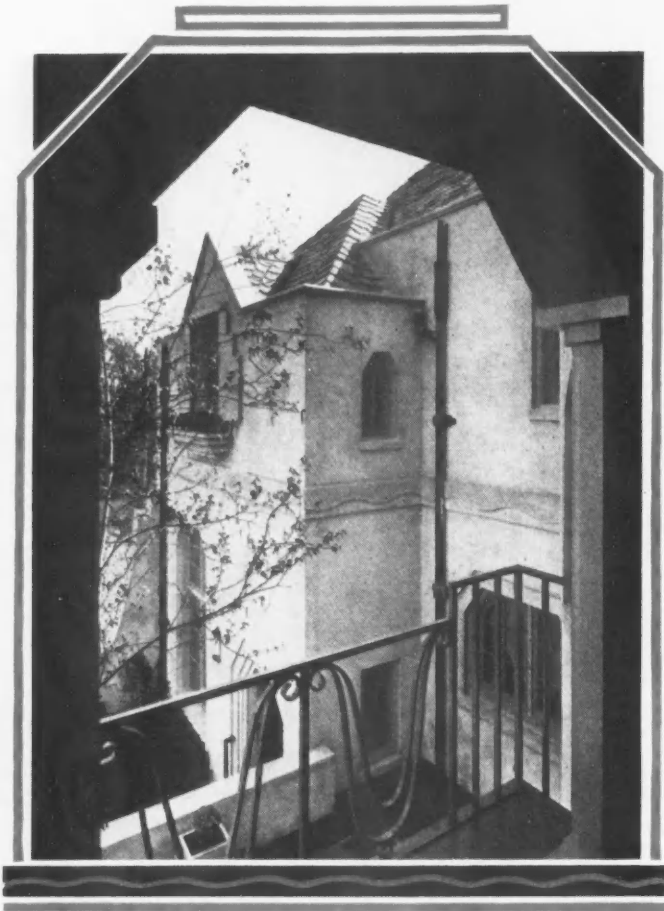

**A** HOUSE designed on modernistic lines, believed to be the first in America, opened recently in Overbrook-Hills-in-Merion, just outside Philadelphia, Pa. Thousands of persons, including many architects and decorators, viewed the home on the opening day.

E. Allen Wilson, architect, designed this unusual home in collaboration with McWilliams and Meloney, builders. J. B. Van Sciver Company designed the special modernistic furniture and draperies.

"Modernesque," as this home is known, is an endeavor to present to the public a house not alone modernistic in exterior and interior design, but also an exhibit of materials as near modern as the American market affords.

To illustrate: Common brick was used as the main construction material. It was combined with stucco, and where the common brick itself was featured, the brick was laid in cement mortar with an inconspicuous joint, modernistic both as to bond and as to mass outline. The accepted angles and square forms of modernism were utilized. The base course in the front elevation illustrates this.

The stucco is a smooth sand finish tinted a light cream, a color used largely because it blended well with certain plaster plaques of ornamentation which were used on the exterior. The cream color is almost white. Many of the European examples where stucco has been used are either this color or

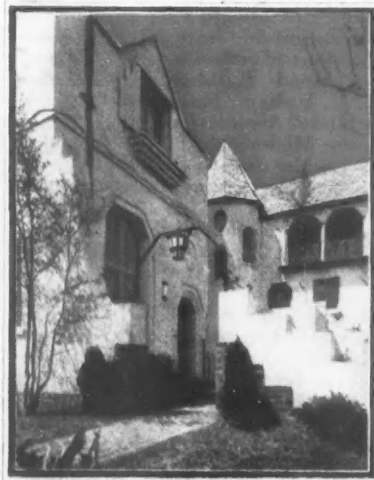

# Mod e

dead white. The plaster ornamentations and plaques, although of a waterproof form of plaster, appear to have been sculptured on the exterior surfaces, really a part of it, largely because they were washed with a thin coating of stucco.

The modernesque walks, both entrance and court yard, although of common brick, are so laid that a modern pattern has been developed which is thoroughly in keeping with the home.

An innovation, believed to be originated by McWilliams and Meloney, the builders, is a cast aluminum peacock 13 feet tall, and a modernistic tree and shrubbery 10 feet tall which have been applied to the stucco. These are painted black, in vivid contrast to the light background, and in keeping with the modernistic theory of decoration of sharp contrast. McWilliams and Meloney believe this form of decoration is the initiating of an interesting method of ornamentation—a new building treatment in America.

Where possible the builders gained deep shadow lines about all windows and doors.

Where space permitted door jambs are formed with at least three recessed surfaces. The octagon heads, although very simple and a very old form, seem typical of the modern school. They are simple, pleasing, and of excellent balance, and true to the modern trend.

Commenting on the design and construction methods used in obtaining the effects in "Modernesque," one of the members of the firm of McWilliams and Meloney said:

"We have also endeavored to secure horizontal shadow lines, both straight and wavering, but in every case most sharply defined. Our window heads are unusual in their proportion.

"In our doors we have used another idea which we believe is of interest. It is a modernistic design in  $\frac{1}{8}$  by  $\frac{1}{4}$  inch hammered iron. This is applied over a plate glass in two of the front doors. A great many of the sash throughout the house were designed with the muntins spaced and arranged in a modernistic manner.

"The leaded glass designs are original compositions following the leading French-Austrian mode. They distinctly resemble modern art.

(Continued to page 112)

# ernesque

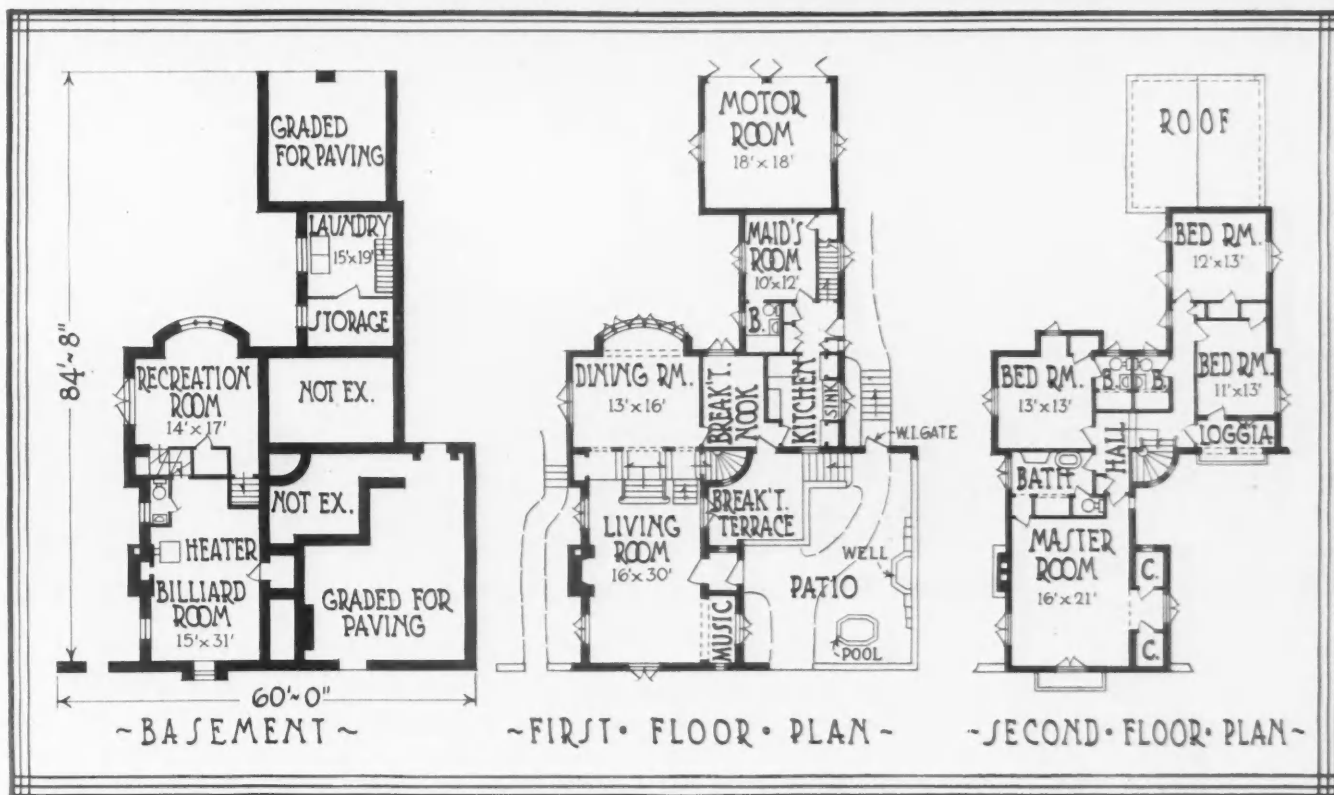
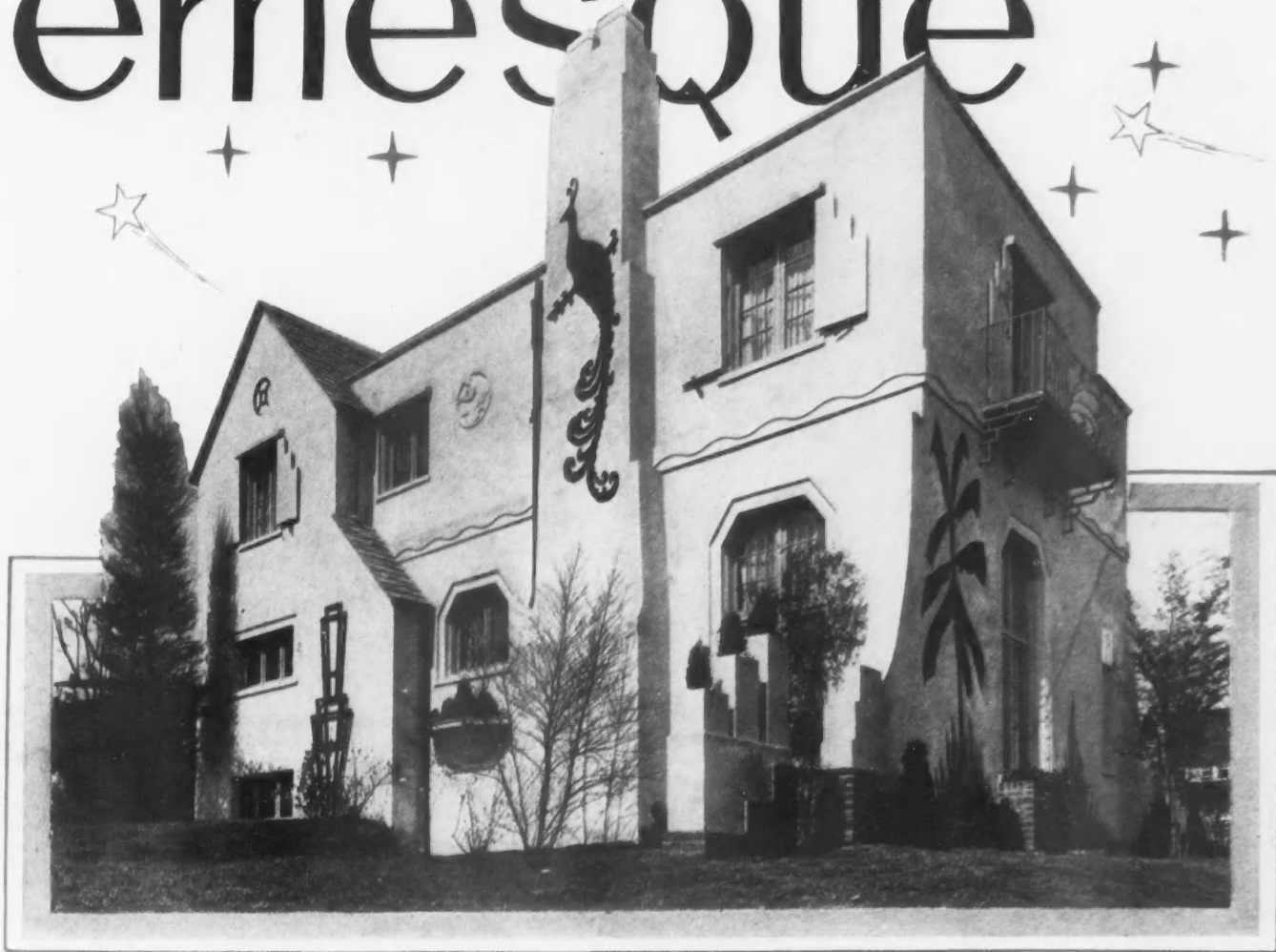



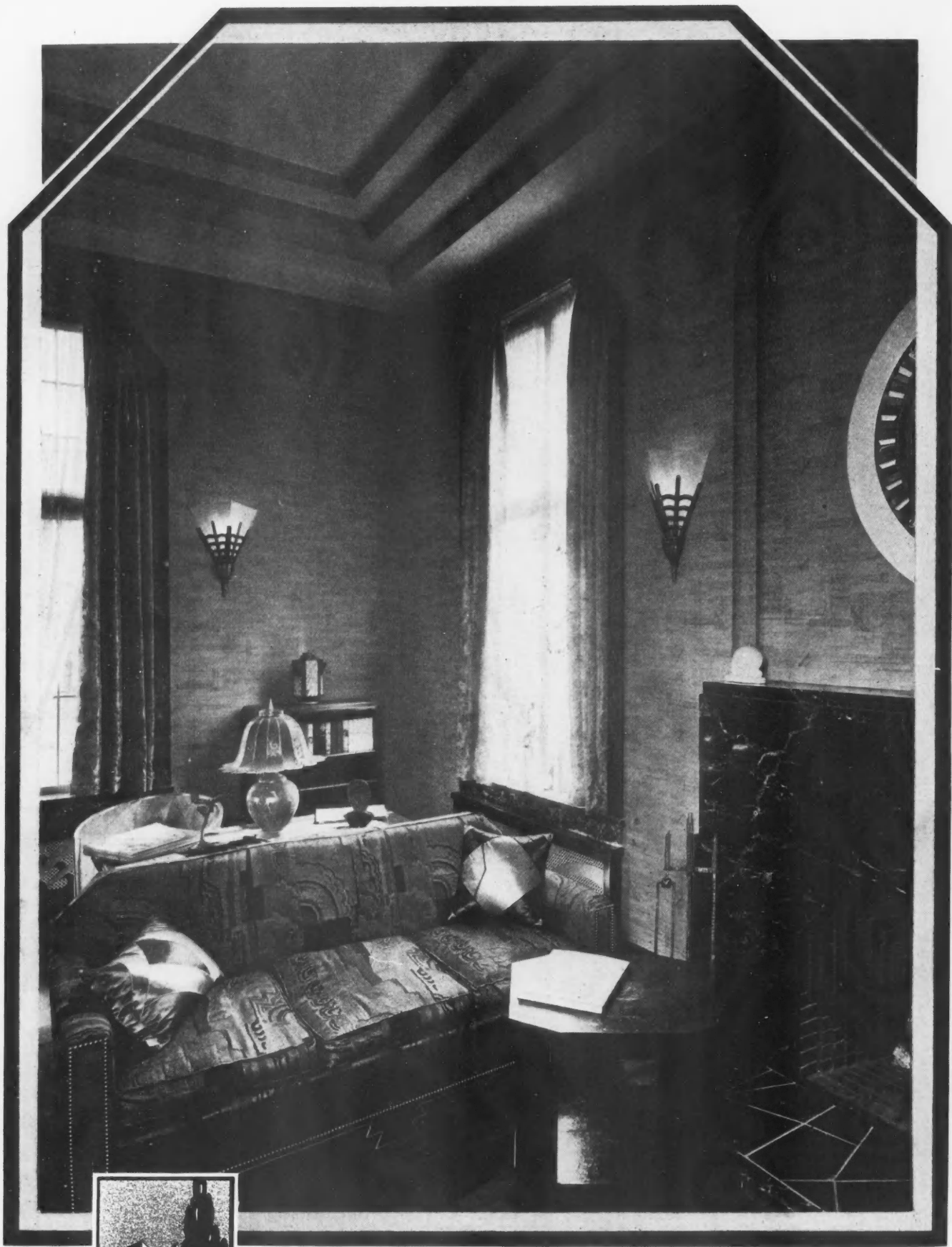

A corner of the living room in "Modernesque," the modernistic home at Overbrook-Hills-in-Merion, just outside Philadelphia, built by McWilliams and Meloney, builders and developers. This view shows the black and gold marble fireplace. The high windows are effective for their beauty and use. The three level ceiling is finished in different color tints.



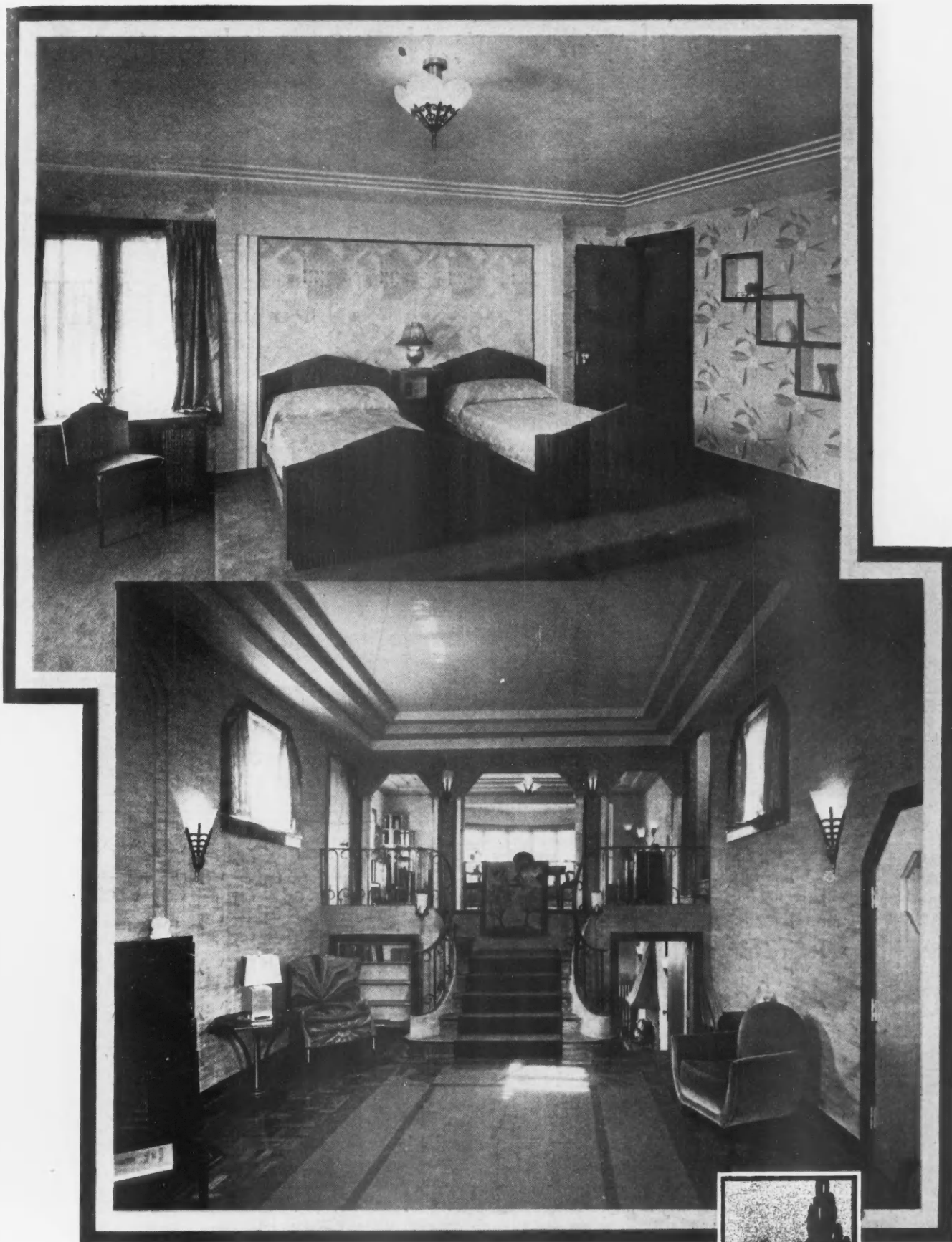

Above: The master chamber in "Modernesque." The twin beds are placed on a platform. Modernistic art contributes the recessed design in the wall.

Below: The living room and dining room. The dining room is elevated 5 feet above the living room and is reached by a divided staircase of oak with hammered iron railings.



# FRONT ENTRANCE

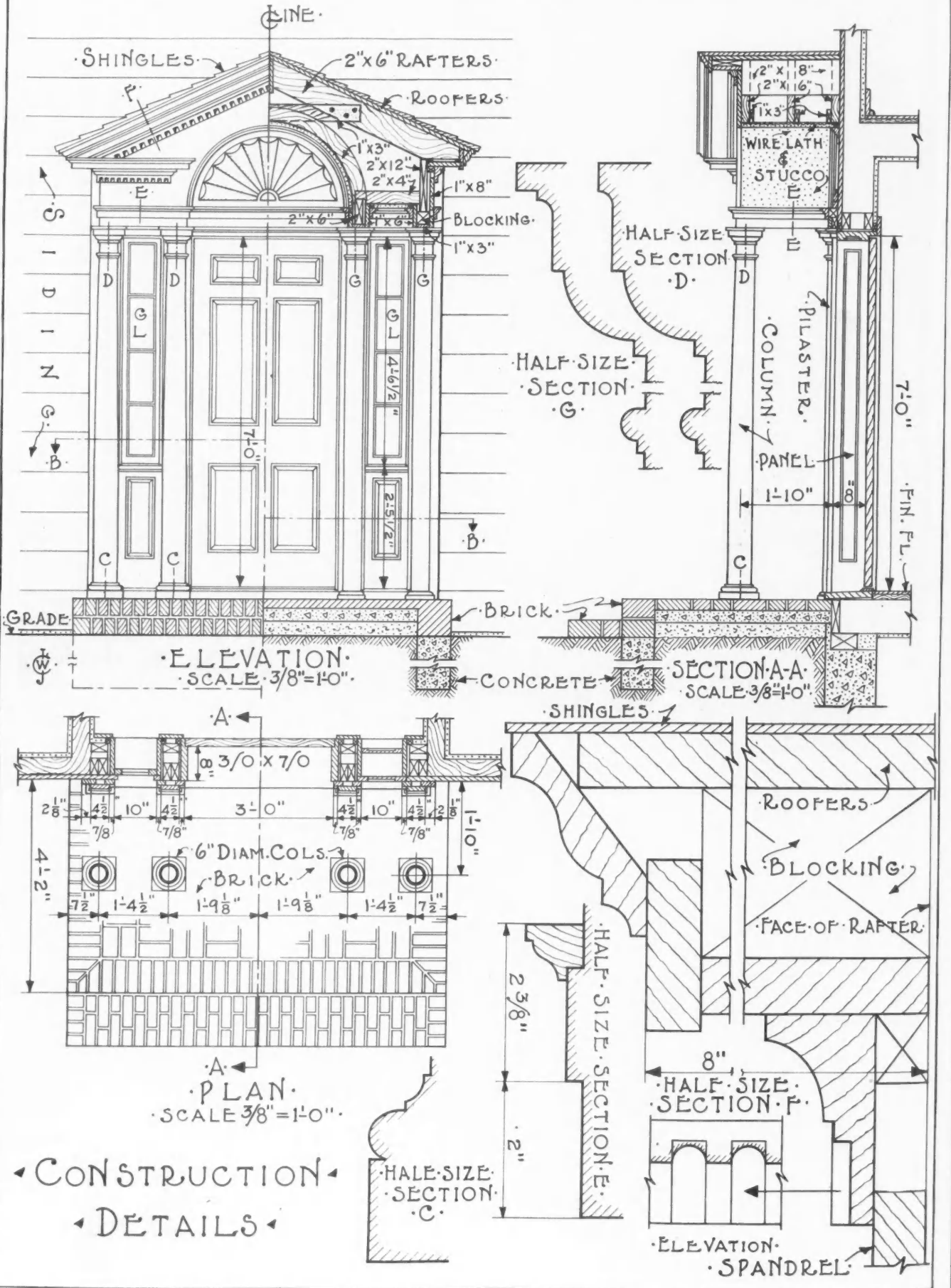

## CONSTRUCTION DETAILS

Co  
se  
T  
If t  
divi  
it ex  
caus  
or p  
ity?  
hum  
mal.  
Th  
to t  
caus  
will  
entra  
finan  
to fi  
choo  
of it  
Ch  
the s  
page  
our

In  
build  
This  
stant  
45 fe  
ing l  
store  
the v  
urme  
inclu  
the c  
Th  
ing v

# How to Build the Colonial Entrance

Pictured on  
Front Cover

*Construction Details Pre-  
sented on Page Opposite*

**T**HE entrance doorway may be regarded as the architectural keynote of the home. If the entrance can define the individuality of the house, what shall it express? Shall it be inviting because of its broad, hospitable look or repelling because of its frigidity? It can be kindly or forbidding, humble or proud, intimate or formal.

The doorway is really an index to the character of the owner because the man who likes display will invariably select a pretentious entrance to give an atmosphere of financial prosperity to his dwelling. He who is able to find beauty in the simple things of life generally chooses a simple doorway which by the refinement of its detail reflects his love of beauty.

Christmas cheer and hospitality are suggested by the simple Colonial entrance pictured on these two pages in photograph and working drawing and on our Front Cover in colors.

## Store Front Details

Exceptional Design

Illustrated on Pages 68 and 69

In one of the suburbs of Chicago there was an old building on a valuable lot in the business center. This building was 45 by 105 feet in size with substantial brick walls and set back from the street 45 feet. The owner had started to wreck the building before the architect was called in to plan a new store building for the site. The architect stopped the work of demolishing the structure, took measurements and made use of almost all of the old work including the roof construction, and thereby saved the owner about \$9,000.

The front wall only was removed and the building was extended to the street, making a building

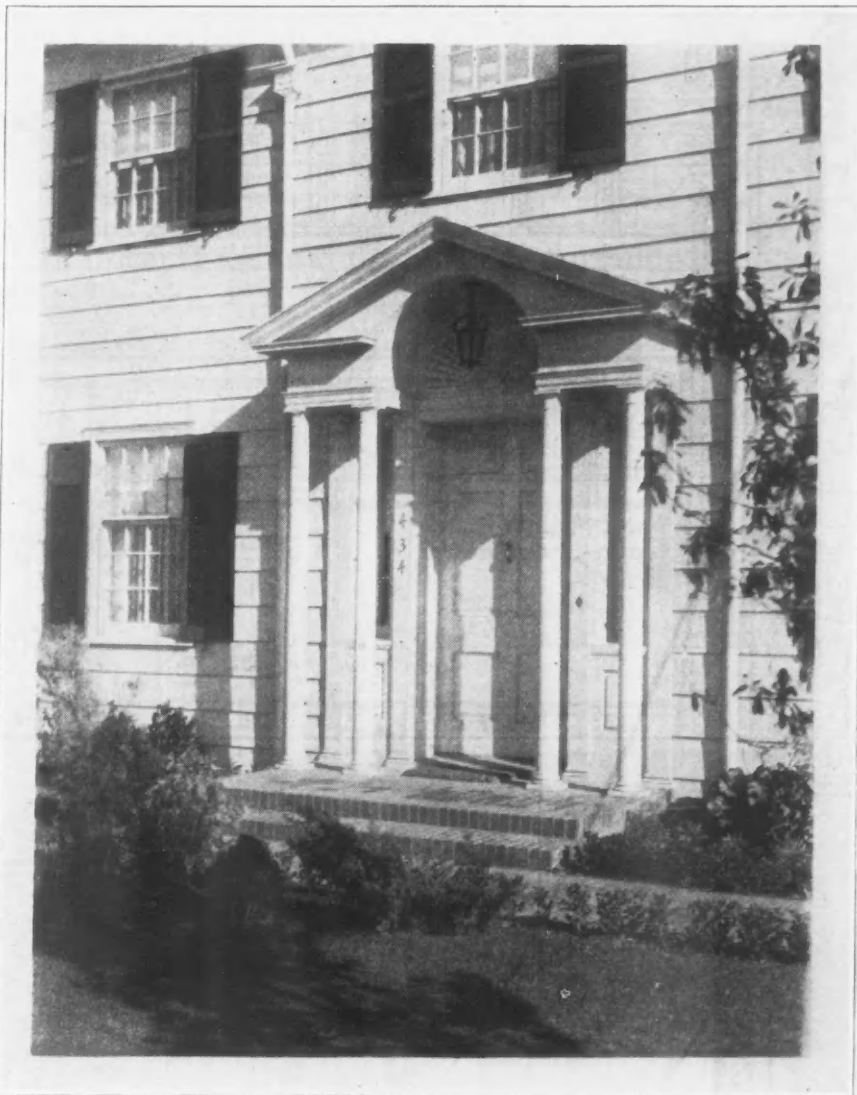

T. BEVERLY KEIM, *Architect*

45 by 150 feet. The drawings on the next two pages show the street front of the store. The design shows good taste and individuality and yet is not too great a departure from other stores on the street.

The show windows were designed for the display of dry goods, clothing or similar merchandise. The backs and ceilings are of plain wood paneling treated in color. There is modern window lighting installed which will be hid by curtains. The glass is supported by copper store front construction with dark green marble under the windows, which gives a pleasing color combination with the gray stone work. Note the wide entrance with composition floor, which extends throughout the entire store, and Spanish plaster ceiling. This ceiling as well as the ceilings of the show windows is at the main transom bar, so that the large transoms with their prism glass give good light to the store. Should it become necessary in the future to divide the store into two stores, only the door and adjacent sidelights would have to be changed into two doors in order to do so.

So that frost will not form on the glass the show windows are ventilated by using copper strips at the bottom of the glass with small vents, and a register near the ceiling connected up through the walls to the outside air. This method keeps the air in the windows at about the same temperature as outside.



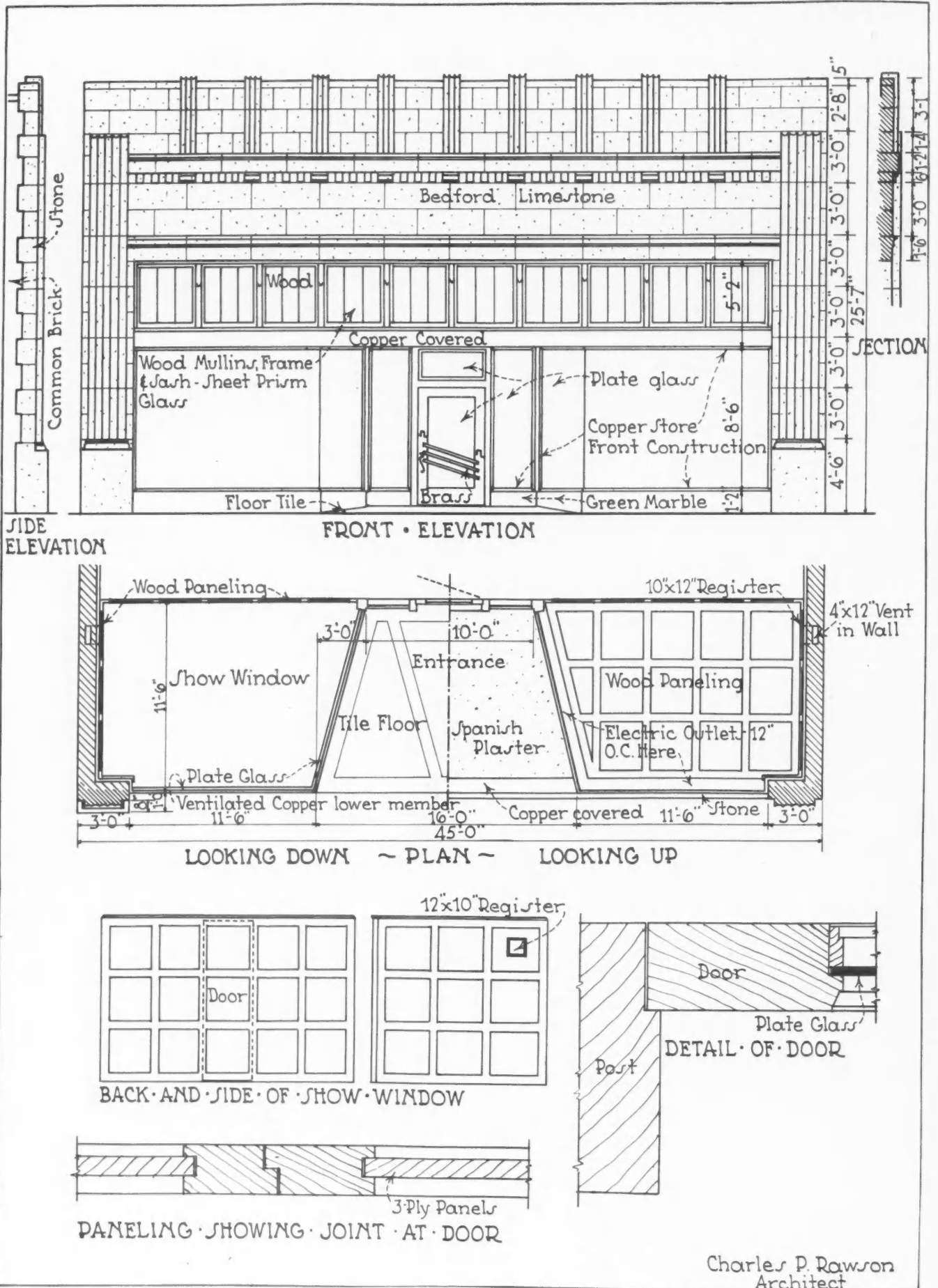

Charles P. Rawson  
Architect

Store Front of Limestone, Glass, Copper and Marble in a Sensible Moderne Style.  
Other detail opposite.





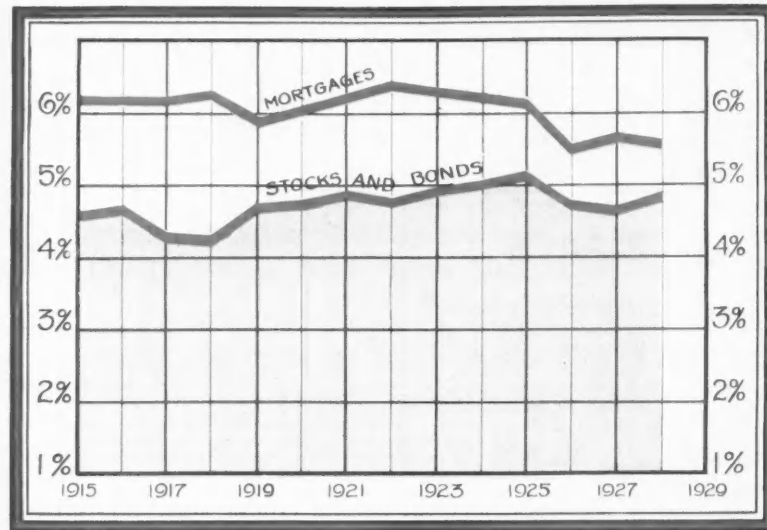

Investment Yield Record of  
104 Life Insurance Com-  
panies for Fourteen Years.

# Mortgages Yielding Higher

*Survey Shows Superior Earning Power Over Stocks and Bonds*

**T**HE mortgage investments of one hundred and four life insurance companies in the United States in 1928 yielded an average rate of return which was 0.62 per cent higher than the average yield of stock and bond holdings of the same companies, according to figures made public in Best's Life Insurance Reports.

The average yield on mortgage investments of all life insurance companies included in the study for 1928 was 5.49 per cent, whereas the average return on stock and bond holdings of these companies was 4.87 per cent. In 1927 the average yield on mortgage loans was 5.63 per cent, whereas on stocks and bonds it was 4.74 per cent. In 1926 these companies' mortgage investments yielded an average return of 5.55 per cent while the average return on their stock holdings was 4.79 per cent.

Prior to 1925 the yield on mortgages only once fell below six per cent, in the year 1919. Since 1925 the yield on mortgages has been less than six per cent in each of the three years for which data are available. On the other hand, it should be pointed out that the yield on stocks and bonds has been under five per cent as far back as this study goes with the exception of the years 1924 and 1925; when the stocks and bonds show average yields of 5.01 per cent and 5.04 per cent, respectively.

Tabulations recently made revealed the fact that insurance companies up to the end of last year showed a strong preference for mortgage loans as compared with stocks and bonds. The number of life insurance companies whose mortgage loans have shown a greater absolute increase are compared with the number of companies whose holdings in stocks and bonds have increased more rapidly than their investments in mortgage loans since 1925. In making this tabulation the absolute numerical increase in figures representing mortgage loans was compared with the figures representing holdings of stocks and bonds.

Of the 101 companies tabulated in this classification, the figures for 74 companies indicated a greater absolute increase in mortgage loans than holdings in

stocks and bonds over this fourteen-year period.

Stocks and bonds are carried under the assets of the companies at their current market value. An increase in the market value from one year to another would show an increase in the amount of money invested.

**N**ATIONAL banks reported seven hundred million dollars more in loans on real estate in 1929 than they reported in 1926.

These figures are significant for they not only mean that the enormous resources of the national banks are being made available for home building and other real estate developments, but they mean that the real estate mortgage has found additional favor with the Federal Reserve System.

The realtor organizations have just completed a check up to see if the passage of the McFadden Act in February, 1925, permitting national banks to lend on real estate for five-year periods, had resulted in any new money being put into the realty field.

Prior to 1925 the law permitted national banks to make only one-year loans on real estate, and because so few real estate loans are made on a one-year basis or can be made advantageously on such a basis, the national banks were not conspicuous in this field.

On June 30, 1926, the total amount of loans, secured by real estate made by 7,978 national banks, was \$337,393,000. The McFadden Act had been operative but four months then. A year later, on June 30, 1927, an additional two hundred and thirty-four million dollars had been loaned to home builders and real estate operators by the national banks. On June 29, 1929, the loans on real estate, other than farm lands, reported by 7,536 national banks totaled \$1,104,220,000, or an increase of \$766,827,000 over the 1926 figure with 442 fewer banks reporting.

Although there is no definite information to show that the increase of the real estate business of our national banks is due to the enactment of the McFadden Act, this law after all only gave the banks the opportunity to place such loans if they so desired, and apparently they did so desire immediately.

# Waste, Not High Wages, Makes Building Costly

BY MORTON C. TUTTLE

*President Morton C. Tuttle Co., Builders, Boston, Mass.*

WHEN "the cost of building" comes under discussion—and the discussion starts whenever a building does—one very promptly begins to hear unfavorable comments on the willingness, the effectiveness and the skill of the construction forces on the job. Occasionally the general contractors and the various sub-contractors do not escape this review. Nevertheless, I hold the opinion and believe that I can adduce some evidence to show that our modern union labor men, skilled and unskilled, work quite as intelligently and quite as effectively as ever their forefathers did.

The complexity of our buildings and our higher wage levels do not account for the high cost of building. Facts will show rather that a significant part of this high cost is unnecessary waste resulting directly from strange failure to adapt procedure to modern requirements.

Using the parallel between the cost of daughter's clothes and the cost of a new building, it may be that daughter has bought very economically a dress of a kind that is far more expensive than its use justifies. Looking at the matter in one way, she is a close buyer. Looking at the matter more broadly, she is extravagant. Just as in clothes, there is a wide field for selection in buildings.

## Extravagant Buildings

Primary considerations in building are type, size, arrangement and choice of materials. I have observed the building of factories for manufacturing similar metal products, for instance, where some were built of brick and timber, some of steel with timber floors, some of steel frame with concrete floors and others of all concrete construction.

Here were four types of structure serving practically like purposes but varying probably 20 per cent in cost. If the less expensive type was as adequate for the purpose as its particular owner believed, then, however efficiently the other buildings were built, they were extravagant.

I have known warehouses for bulky, lightweight merchandise to vary 20 per cent in size only because of different arrangement of the storage space and facilities. If by better arrangement a smaller building will provide adequate facilities, then the building of a larger one, other things being equal, spells waste.

A new building looks so convincing and so fine that it is often difficult to realize that the particular building going up may not be at all the sort of building that should be built. If the building chosen is not of the most economical type, not of the most economical arrangement and size, and not of the most economical materials, this only means that, before a single sod is turned, values have been lost which no subsequent savings of method or purchase can restore.

## Losses in Design and Detail

Assume that the proper type of building has been selected, that its size and arrangement are correct, then consider that the building is made up of many parts, some of which require ingenuity and much time to assemble. You will find that for almost every part of the construction there is available a selection of details, the designing or assembling costs of which vary widely. From the angle of sound engineering, use or appearance, the extra cost of a detail may yield no extra value whatever. Yet it commonly happens that complicated details are used where simpler details are available; that costly materials are used where economical materials will suffice.

Obviously, an economical structure is the sum of economical details. Yet the average building design will not bear the test of intelligent cost analysis. I have known the steel frame of a building to be so designed that sorting its members was like sorting jackstraws out of a pot. Structurally, the framing was sound but an equally sound, equally useful and much less expensive frame could have been achieved with fewer parts. I have known 8 per cent to be saved in the total cost of a simple factory building by leaving out a useless line in the brickwork and changing very moderately the spacing of columns. It is my deliberate judgment that the cost of buildings designed by all but a few of the truly great designing offices cost on the average 5 per cent more than they need to cost.

## Waste from Inexperience

Any great designer is eager to learn from the men who build and the greatest of the designers do have an astonishing fund of information of the practical sort developed by a builder and his cost accountants. Only the great offices, however, can maintain a practical expert on costs. In the general case, the working out of details of plans and specifications must be delegated to men who are only theoretically trained; and one of the awful sights of nature is that of such a subordinate searching a handbook for the most economical way of accomplish some practical result.

I have seen plumbing organizations in consequence trying economically to execute a design more complicated and impracticable than any plumber would tolerate from his own organization. Yet, because this extravagant arrangement was prescribed on the plans and specifications, good workmen in truth sweat hard to get the thing together, and the owner to pay for it, and the effort was wasted.

Basing their appeal on the fact that the average of designs and specifications can be so simplified, it is little wonder that a new profession of practical cost-engineering is coming into the building trade, and with real promise of successful achievement.

*(Continued to page 110)*



# Where Quality and Beauty



The Main Entrance to Gladstone Manor. The old Manor House is now being used as a sales and construction office by the developer.

**S**ITUATED between two main highways between Philadelphia and Baltimore, close to the Philadelphia line, lies a development with many points of excellence that are sure to be of considerable interest to our readers. We refer to Gladstone Manor, a development sponsored by W. Percival Johnson, and situated in Lansdowne Borough, Pennsylvania.

What makes it a very convenient suburban development is the fact that it is within twenty minutes' train ride of the Broad Street Station in Philadelphia. The railroad's right-of-way is the southeastern boundary of this development, and its northwestern boundary is Baltimore Avenue, the main automobile highway between Philadelphia and Baltimore. In years gone by this avenue was known as the Baltimore Pike and is still referred to as that by old-timers in the neighborhood. A trolley car line runs on Baltimore Avenue to the city line of Philadelphia where another trolley may be had, taking one directly to the heart of the city; the running time being less than forty minutes. A railroad station, "Gladstone," is at the southern end of the development.

The property was an old-time estate probably developed between seventy-five and eighty years ago. The old stone Manor House is still there, being used now as the developer's office. The ground slightly hilly contained many fine trees which have been carefully spared by the developers.

The entire tract has been most artistically laid out, and while its streets cover over a mile in length, the layout has been so carefully taken care of as to

secure perspectives that seem larger and longer than the reality. As to railroad stations, "Gladstone" is directly off the Burmont Road entrance to the property, while the "Lansdowne" station is only a fifteen minute walk to the north.

Going by car south from Philadelphia on Baltimore Avenue one is immediately attracted to the park-like entrance to the development made by the junction of Gladstone, DeForest and Mansfield Roads.

The photograph of this entrance but faintly shows its real beauty; the landscape work has been most artistically carried out; flowers when in full bloom add to the color touch so much enjoyed by the discriminating.

The streets are uniformly forty feet wide, with an eight foot parked sidewalk on each side of the curbed road, which is twenty-four feet wide, sufficient to avoid crowding of vehicles in this park-like development of high grade modern homes.

What impresses one so favorably on a first view of this development are these remarkable streets; they are all so clean and wide and attractive.

The twenty-four foot roadbed is of concrete six inches thick, reinforced with a steel mesh laid on top of a drainage base, so there is every likelihood of these roads lasting for many generations without the necessity of repairs.

The engineering features of this road building has been handled with considerable skill; expansion joints are plentiful, there-



An Interesting Detail of One of the Houses in Gladstone Manor, Lansdowne, Penna.



# Meet The Story of the Development of GLADSTONE MANOR

fore there will be no rearing of roadway in hot weather. At the corners and curves special pains have been taken with the expansion joints. One main expansion joint has been placed in the middle of the roadbed dividing it into two twelve-foot wide strips. Expansion joints are also provided at each side of the curb; see the photographs—they plainly show these joints.

A little over a mile of this 24-foot wide street has been laid and approximately two miles of 4-foot wide sidewalk and curbing; so the concrete job was one of some magnitude.

The installation of the pipes and the laying of street curbs and sidewalks was let as a separate contract to a concern making a specialty of this sort of work, but supervised by the developer's engineer, Mr. James J. Moore, who was also responsible for the layout of streets.

Of course, previously to laying the roadbed, sewers were laid together with pipes for water and gas, also electric light and phone conduits. There are no overhead poles to disfigure the park-like appearance of Gladstone Manor. Artistic light standards are placed throughout the development.

At the present time one hundred houses have been completed out of the two hundred and eight contemplated to be built. Each house built has a garage, some with two-car garages.

The garaging problem has been handled in a number of ingenious ways by a peculiar division of the rear lot lines. An examination of the plot plan will disclose quite a number of odd shaped rear corners,

these providing room for garages in one group on different lots, which secures the maximum amount of rear yard space. In some sections where the ground is hilly rear driveways have been provided for access to garages, which are here placed in the house cellars.

There is an absence of sameness in the buildings of this development which is decidedly pleasing. Each house seems to have been handled as a different problem, yet in harmony with the complete grouping of homes.

The old manor house is now used as a selling and administrative office as well as a community gathering place; it is a wonderful example of old time first-class building. It was placed so that the living rooms would secure the maximum amount of sunlight in the winter while the porch extended around on the north and east sides of the house which insured there a shady retreat for the major part of the summer days.

Too little attention is paid now-a-days to the proper orientation of houses, and it will be worth while for builders and developers to consider the subject, since often a house will not sell because the wise prospect will see that something is wrong, even if he cannot tell what the fault is.

The exteriors of all the houses are different, as well as the grouping. Some are detached houses, others of the twin variety, while still others are practically detached except that they are joined together by a little wing in which the garage is located. The different types of houses are scattered about the

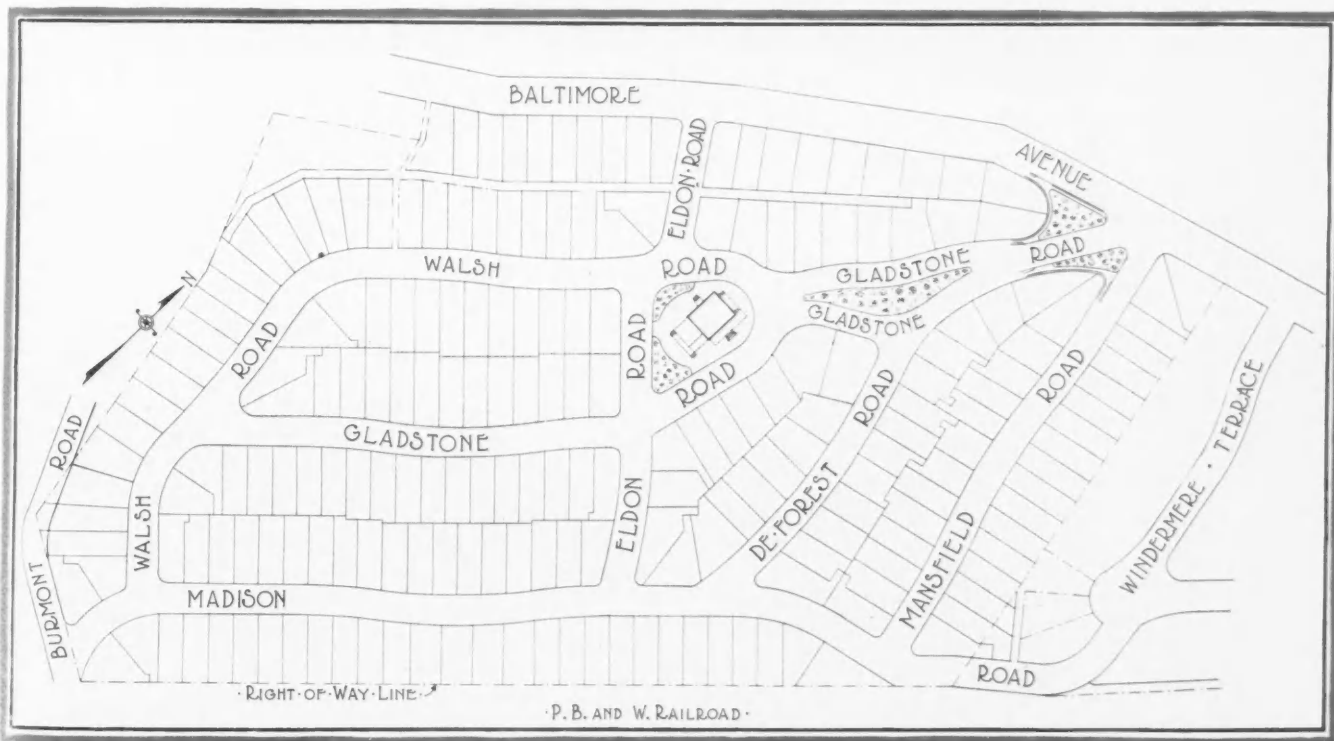

The Plot Layout of Gladstone Manor Has Been Carefully Designed so as to Obtain Fine Views from Almost Any Point in the Development. Note the division of the back lot lines to accommodate the garages. There is over a mile of streets in this development.

# A Model Home to Attract Prospects

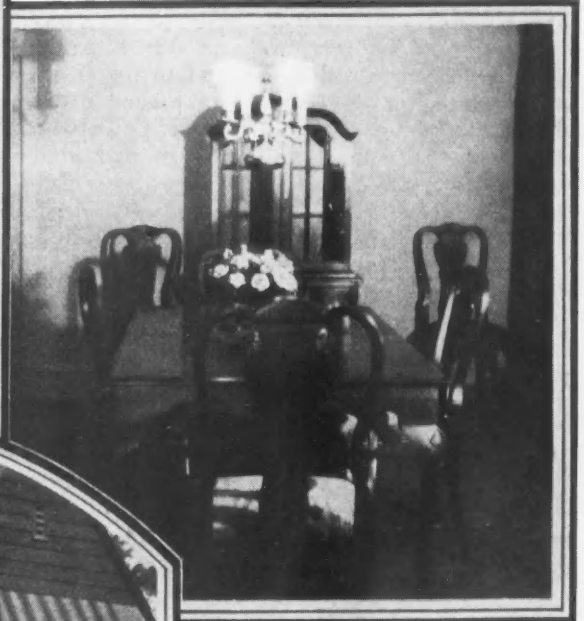
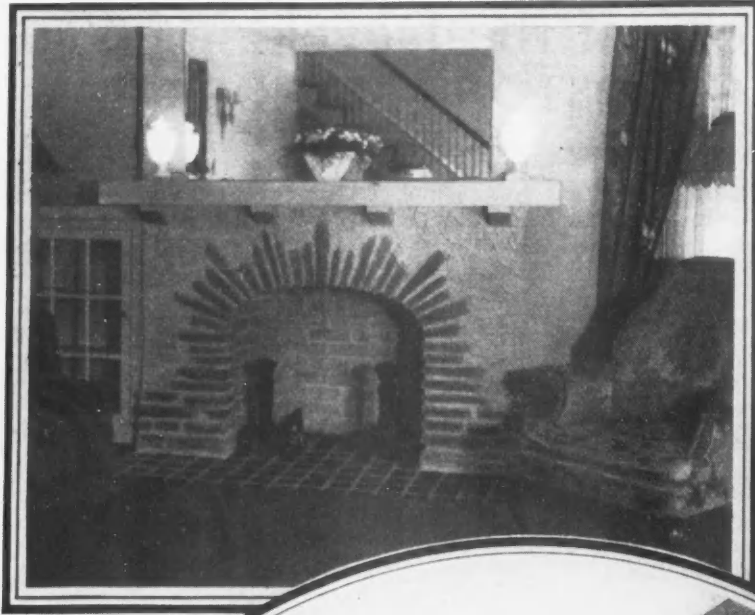

Very Attractive is this Norman Type Home Selected for Exhibition as a Sample House. Its interior has been carefully and appropriately furnished in dignified yet not too expensive a style. It serves as an educational study for visitors. A keen salesman on the job picks out those who show by their interest that they are real live prospects.

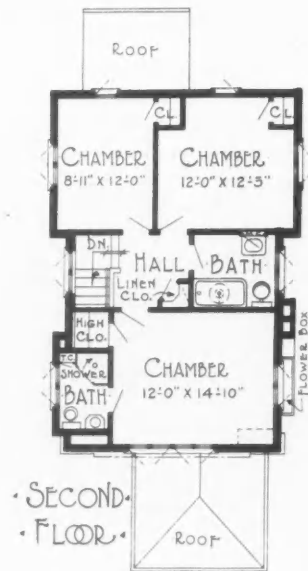
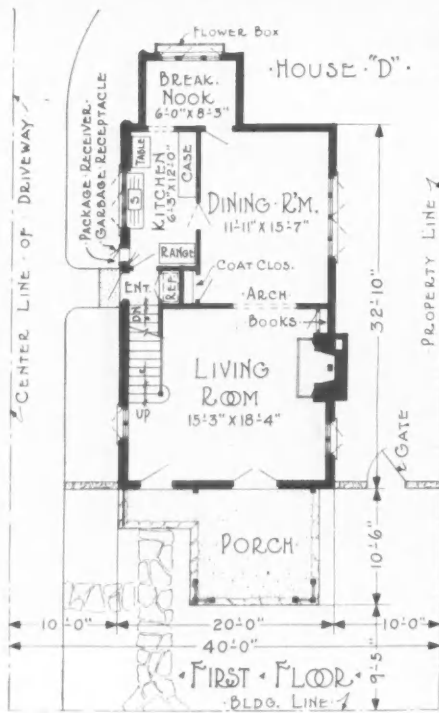

development so that there is no monotonous sameness.

The twin houses are especially attractive. They have the appearance of a large single family residence. Some designs have been cleverly worked out in English style and practically the same floor arrangement has been used for an Italian Villa. E. Allen Wilson, R. A., of Philadelphia, was the architect.

The most novel arrangement is that of the attached garage types. Here the two adjoining houses are separated by a service court yard fronting the two garages. The two houses making up this unit are alike in floor plan, but of course the one being the reverse of the other.

The exteriors are of the same general type of architecture but still different. For instance, an English Cottage type will be selected for one house and its adjoining neighbor will be derived from the Norman. In another case, a Dutch Colonial design will be linked to a New England Colonial. By carefully handling the garage problem the architectural result is very attractive.

In material selected for the exteriors there is wide variety. Some houses are of combination stone, brick, stucco and shingle, while others are built entirely of one material. On account of a local ordinance all

At Last . . .  
SOMETHING Really NEW



GLADSTONE MANOR  
- LANSDOWNE

A glance at the picture above qualifies our opening statement. Prior to the advent of the "Single House" Gladstone Manor comprised solely semi-detached homes; but today we introduce the "Single House" finished both in Colonial and English designs. Note the walled court effect between houses—made possible by the offset garage, which in reality is the rear of the house. Privacy is given this court by the artistic gateway at front entrance. Quarters for maid with bath are above the garage proper, with rear stairway leading direct to kitchen. Never before in our building career have we known of any single idea or innovation that has caused so much favorable comment. At last we can offer this distinct departure from the usual exterior treatment. Again we reiterate "SOMETHING REALLY NEW."

The interior treatment of the "Single House" meets every requirement of the most exacting. Each room boasts a regulation for spaciousness and adaptability for furnishing. The first-floor plan will attract you from the cheerful living room to the furnished kitchen and breakfast room. Four chambers, three baths of colored tile and stall shower, comprise the second floor. The basement is finished and proves ideal for either child's room or billiard room. Such phases as "brass piping," "Crown hardwood flooring," "Chromar bathroom fittings" and other nationally advertised products mean much to the man of the house for their low cost of up-keep. Gladstone Manor in Lansdowne is but 18 minutes from Broad Street Station—and is serviced by an electric trolley car. The communication fare is less than 15 cents.

W. PERCIVAL JOHNSON

Developer & Owner

Motor on the Baltimore Pike, three blocks west of Lansdowne Avenue in Lansdowne.

Descriptive Booklet Mailed on Request

Advertisements Similar to Above  
Were Inserted in Philadelphia  
Papers to Attract Prospects.

roofs are of fire resisting material; slate, asbestos or tile have been used. In the twin house groups a fireproof party wall is carried a foot above the roof. In the house construction first-class material and well advertised equipment was used as was to be expected in houses intended to be sold to a discriminating public.

Mr. William J. Thomas, in charge of sales for W. Percival Johnson, the developer, is an interested reader of the AMERICAN BUILDER. Mr. Thomas knew the sales value of practically each item entering the construction of the houses, and this is why they were included.

A clever sales point was that the finished wood floor was not put down in the houses. Prospects walked over the rough floor, but when they decided to purchase a house then the finished hardwood floor was laid after the wall decorating was completed. The material for this floor was a ready finished oak flooring which comes already waxed and finished. When the floor was nailed down the buyer received a floor absolutely free from scratches and wear.

A feature of the kitchen was a kitchen cabinet of the domestic science pattern, and this seemed to be quite an attraction to the women visitors. The kitchen floor was of linoleum.





Among the other items noticed as being used in these houses were hot water boilers and radiators with heat regulators. The plumbing fixtures were of high quality. Electrical wiring conforms to the Red Seal standards. All the houses are insulated.

As mentioned before, 100 houses have already been built, this being the quota for 1929. Building of the other houses will be resumed next spring. The selling of the houses was a most important job; at the present time there are but few houses remaining unsold. Advertisements have been inserted in various Philadelphia newspapers. A reproduction of one of them is presented in this article. Other advertisements are along the same general line.

In the advertisement the room layout of the houses is particularly stressed; also their exterior design and materials of which the houses are constructed. Then as a final clincher, the train service is mentioned, to-

gether with the low commutation rates.

Every ad. carries a line to send for descriptive booklet. This book is a small but attractive affair, and handsomely printed, the house design being shown in color. It gives all the pertinent facts with full instructions how to reach the property.

One of the houses has been completely furnished in excellent taste and this is always left open for visitors. The sample house is illustrated in this article (Page 74) by both exterior and interior views.

There is always a salesman in attendance at this house who keenly watches the different visitors and he is usually able to pick those who can really be classed as prospects. They are immediately approached with a few tactful remarks to draw them out and then, if they show further interest and the house is within their price range, they are conducted to other houses already finished as well as those under construction.



In a Group of Houses on Mansfield Road—the House With the Awnings Shown in the Middle is Completely Furnished as a Sample Exhibition Home.

Read in The JANUARY ISSUE

★ The story of MYERS Y. COOPER, *Builder* ★  
—Now Governor of Ohio

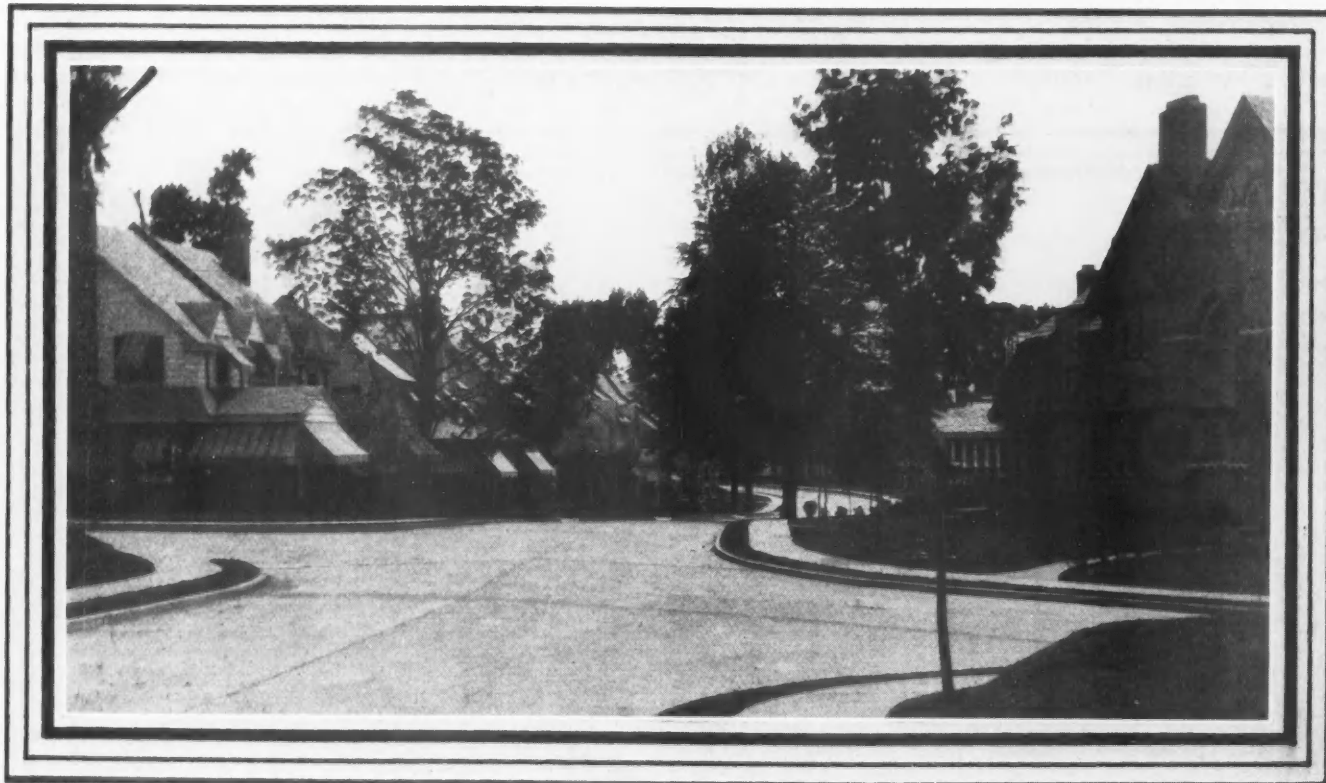

The Above Picture and the One on Page 75 Show Streets in Gladstone Manor. The concrete roadways are 24 feet in width; note the expansion joints to make a first-class job. The absence of overhead wires adds to the attractiveness of the streets.



The Glenn E. Holmes Garage, Chicago;  
Davis D. Meredith, Architect.

THE public garage or car storage building is a strictly ultra modern structure, even more modern than the motor car itself. It was more than ten years after the motor car began to be produced in large quantities that it became a nuisance and interfered with traffic when parked in continuous lines on the down-town streets of our cities. Cities with narrow streets and congested districts were first to put out "No Parking" signs; consequently, they were the first to make down-town storage business a paying venture.

The first buildings to be used for down-town storage were, in most cases, old warehouses and manufacturing buildings, fitted with freight elevators; and these, while they helped out temporarily, soon showed the necessity of buildings constructed especially for car storage purposes. Motor car travel has long demanded facilities for night storage, but this has not needed a great volume of space, and has always been handled by the car dealers, service stations, and a few one or two story storage garages, of the old style, located near the hotels.

Travel by automobile has increased so amazingly, of late, that the old facilities are no longer adequate and this, together with the no-parking ordinances, has made the large parking garage a profitable proposition, because the space can be used twice and often three or four times a day. In the morning the office man parks his car for the day; but there are at least two sets of shoppers, out of town salesmen, and suburban business men, who park for only a few hours

# Public Garages

*A Discussion of the Layout of Special Buildings Devoted to the Handling and Storing of Motor Cars*

By TOM WILDER

during the day. Then there are the theater patrons in the evening and the all night customers. The day parking and night parking are divided into two shifts of approximately twelve hours each. The miscellaneous short period parking will sometimes turn over several times, and bring in about as much revenue as the combined night and day storage, although usually less per car since the intervals are short.

This shift arrangement and the possibilities of using the space several times have brought the storage business to a point where it can pay interest on an investment in a first class building, constructed especially for the purpose in a convenient location. In spite of this the majority of the garages are found on the border of the business district.

In surveying the various systems of storing cars on a large scale, we find that they are all practically alike, and that the difference lies in the method of getting the cars into the storage spaces and returning them to the customer, rather than in the method of placing them.

Size and general convenience, as well as the ramp or elevator system, are big factors in the efficiency of the storage garage. Roughly, preliminary figures can be based on 230 to 300 square feet per car, and it would be well to try several layouts and handling systems before anything is adopted.

The best storage unit has a minimum width of fifty feet which, for average length cars, gives space for a central aisle with storage spaces facing it on either side.

For the longest cars the width should be greater, from fifty-five to sixty feet. Fifty-five feet will take care of all cars; the longest can be placed on one side with the shortest opposite, on the other side, thus a liberal aisle will still remain. These units may be arranged in any way that will work out to the best advantage in the space available, but they must be placed so that cars will have no difficulty in entering the aisle, either from the aisles of other units or from the ramps

## Garages, \$200,000,000

Buildings constructed for general garage purposes in 1928 and having a value each of \$5,000 or over aggregated 42,212,200 square feet, with a valuation of \$149,163,700. As building activities run in close relation to car sales, the Pacific Coast States and Mountain States would, based on sales, add about one-sixth to the above valuation, or \$24,856,116, making a total of \$173,992,816.

The first eight months of 1929 ran \$16,899,633 ahead of the first eight months of 1928 and if this pace continues we can estimate the 1929 total at \$199,342,266 or, in round numbers, \$200,000,000.

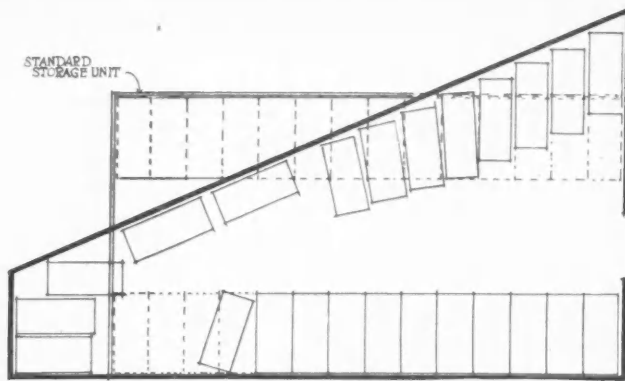

Showing the Advantage of Rectangular Spaces Over Triangular Forms. These spaces have equal areas but the standard rectangular space stores twenty-eight cars against twenty-four in the other, an increase of 14%, which is worth considering.

or elevators. It is always best to arrange the units as simply as possible, since cross aisles waste space and result in confusion. A plot approximately 100 by 200 feet could be divided into two units lengthwise or four units crosswise; the former would give a greater number of storage spaces and be more convenient.

Often there is a little space left over, when the width is divided into standard units; this can be apportioned between the units to give them more liberal width, or if it is already wide enough, fifteen to seventeen feet may be added to one unit, making storage two cars deep on the one side. This practice is not desirable as a regular thing, but it increases the capacity of the unit 50 per cent, although the actual space is only 30 per cent greater, and, if the building is not over crowded, the rear spaces may be used only for overflow. Another way, where there are two units or more, is to place the extra space between two of them, then the car between may enter or leave from either side and the chance of its being blocked is only half as great.

In any but a one story garage, columns are always a problem; and it is imperative that their spacing be made to suit the car arrangement. They are usually placed beside the aisles and between the cars. Their distance apart must be gauged to accommodate two, three or four cars with just enough space for easy handling. Six feet six inches has always been considered a good spacing, but with increased fender width of late six feet nine inches is much better. This gives fourteen feet three inches clearance between columns for two cars, twenty-one feet for three cars and twenty-seven feet nine inches for four cars, against thirteen feet six inches, twenty feet and twenty-six feet six inches, respectively, for the six feet six inch spacing.

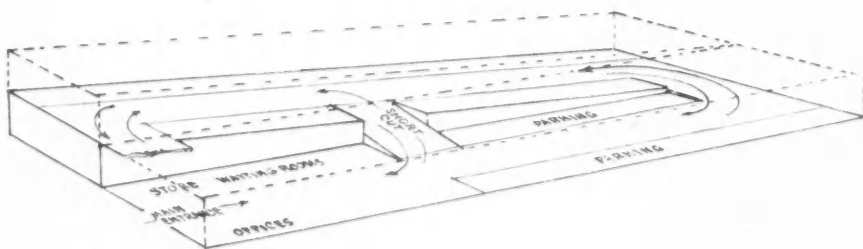

The Inclined Floor Garage Has Never Been Very Popular but Has Interesting Possibilities Especially When Equipped with a Short Cut Ramp. In a 200-foot building the pitch would be only  $2\frac{1}{2}\%$ .

The latter should be a minimum and if the available space with the necessary column width falls a little short, it is sometimes possible to narrow the columns up, adding to their depth to get the proper area.

The greatest problem confronting the multi-floor garage designer is that of getting cars into their berths and out again quickly and economically. There are two basic methods; the elevator and the ramp. Like everything else, the car handling facilities are subjected to a peak load twice daily and if it is a large building there is considerable confusion; especially is this true in the evening when customers are anxious to get home and every minute of delay will be multiplied by five to ten because of the increasing traffic congestion.

While elevators are indispensable in some cases, the ramp has the better of the argument from most angles. It is cheaper to install, has no maintenance cost, and if properly designed it has no greater element of danger than the elevator. It is not subject to break-downs, will handle the peak load easier, and can be, and usually is, operated by the customer, who often prefers to park his own car and get it rather than trust it to an attendant, who, not understanding its eccentricities,

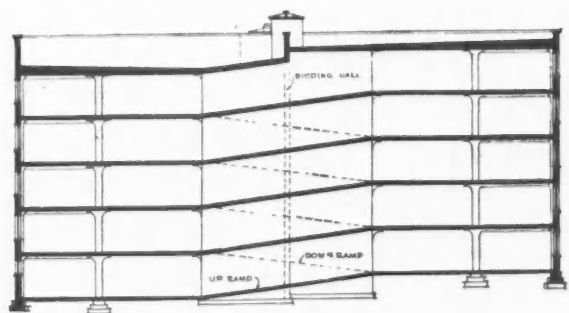
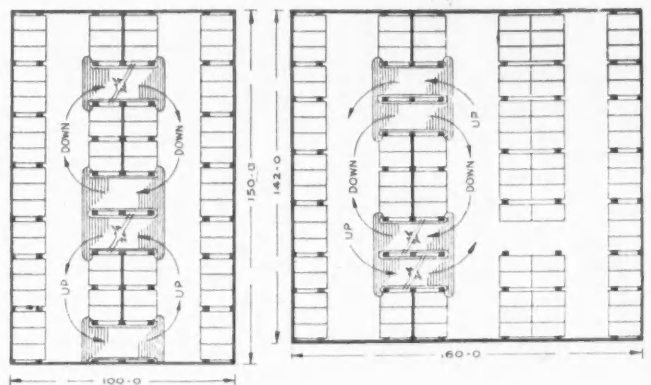

The d'Humy Motoramp System Has Been Sold Very Effectively and Is Used in More New Buildings Than Any Other.

may damage it in some way. Elevators lay claim to more economy of space, but even this may be questioned if they are installed in insufficient quantity to give as rapid service as the ramps. Unless the ramp garage insists on handling all cars by its own attendants, it will get along with a much smaller number than will be possible in the elevator garage.

However, some of the new automatic elevator systems may prove an improvement over the ramp if installation is not too expensive. The ramp has reached about as high



point of perfection as can be expected, but mechanical systems are just starting to develop and may surprise everyone.

There are a great many arguments as to what sort of ramps are best, but it remains a fact that a grade of 15 per cent or at most 20 per cent is most satisfactory and given this definite pitch, and consequently definite length to get from one floor to another, the only way of cutting down the space devoted to ramps and lost to storage is by making the ramps coincide with the necessary passages. This is done in one system by giving the whole floor a slight pitch from one end of a unit to the other with cars stored along the side. At the end of the unit there is a cross aisle connecting with another parallel inclined unit returning and at the end attaining the height of the second floor. For good results this type of building should be a minimum of one hundred feet wide and two hundred feet long.

Another system uses level units and ramps coincident with the cross aisles. These cross aisles are not long enough to permit a floor to floor rise and to cut down the rise the units are staggered, one set half way between the other set, at about five feet intervals (see diagram).

Both of these systems, and other similar ones using the aisles as ramps and inter-communications, are open to the objection that during heavy traffic in the higher buildings there is great interference with parking especially on the lower floors, resulting in congestion and sometimes damage.

Looking at the problem from this standpoint, it may be better to sacrifice a little capacity to convenience and safety, and use either plain straight ramps with a special intercommunicating passage or one of the spiral ramps which is confined to a small space and which in no way interferes with parking or parking passages. There are no rules for designing the straight ramps, either they can or cannot be adapted to the available space; however, they must always be placed in relation to the aisles so that there will be wide easy turns with at least fifty feet diameter in any 180 degree turn; 60 to 70 feet would be better for long cars. Most all cars turn in a circle less than fifty feet, but in practice drivers do not use their extreme turning power at the start.

There are two forms of spiral ramps, one having concentric circular passages, one up and one down, and the other having a double spiral, one above the other, one for up traffic and one for down. The concentric type takes more space because the inner circle must

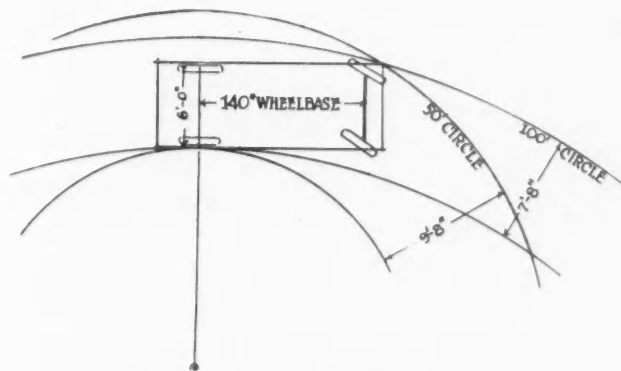

Showing How a Long Car, Six Feet Wide, Becomes Nearly Eight Feet Wide on a 100-Foot Turn and Nearly 10 Feet Wide on a 50-Foot Turn. Circular ramps must be proportioned accordingly.

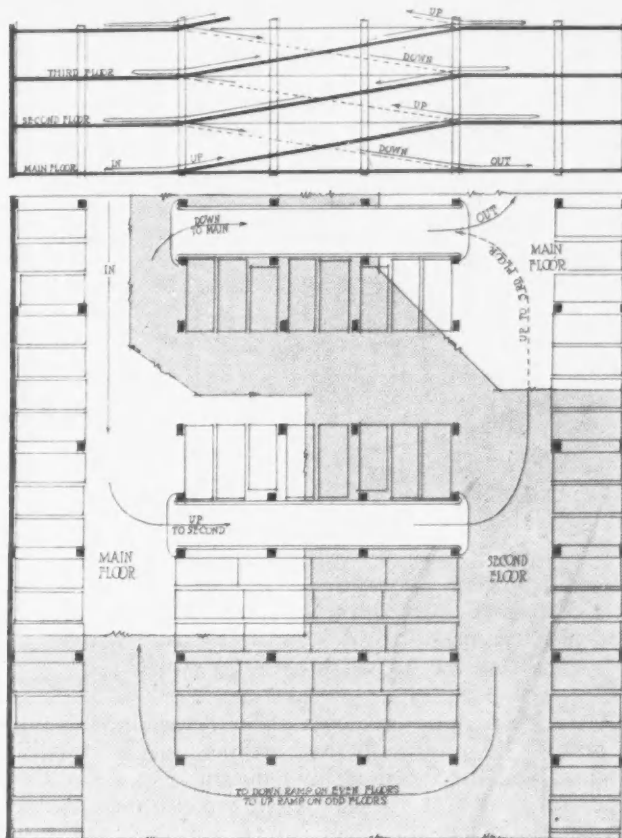

This System Will Give Straight Full-Story Ramps for Separate Up and Down Travel, Is Quick and Economical but Requires a Large Building. The ramps function exactly the same as the double spiral but uses aisles like d'Humy system.

be well over the turning circle of large cars, while the other type may have a much more liberal turn than this and still be considerably smaller than the diameter of the outer of the concentric passages. Because of the fact that cars assume a diagonal position when turning, circular ramps must be wider than straight ones, and for the same reason two-way single ramps are not safe in the circular form unless very wide. If used at all they should have the up and down passages separated by a curb. The double spiral is, in fact, a simplified form of the ramp system employed in the Biltmore Garage, New York, and built about ten years ago. A perspective diagram will explain it better than words or a plan. Each complete turn takes the car up or down two floors and for that reason it should have an installation where the car can come in on one side and leave on the other, as the up entrance is on the opposite side of the circle from the down entrance and the positions are reversed on alternate floors.

Spiral ramps have the disadvantage of making some drivers dizzy and it is very easy to lose one's bearings when going up or down several floors, or to become confused when others try to enter the ramp. It is also said that there is a tendency to dish the wheels of cars because of the excessive strain of continually going down and turning, but as they are the shortest possible route to or from upper floors one can afford to drive a little slower and avoid this excessive strain.

The ordinary freight elevator as applied to car storage is slow, expensive to operate and inefficient, especially at times of peak load. This should only be considered in buildings too small for a ramp.

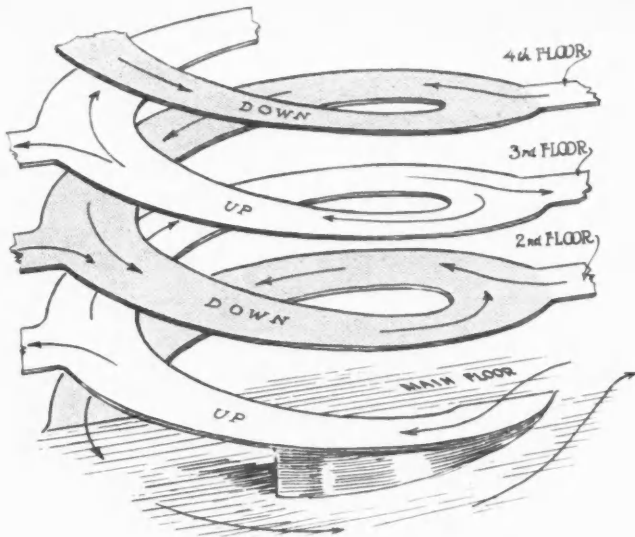

Simplified Diagram of a Double Spiral Ramp Featured in a Recent Garage at Richmond, Va. A complete circle takes the car up or down two stories.

After the parking layout has been determined, it must be brought in tune with the entrance and its facilities for handling the incoming and outgoing cars. If there is perfect design of the ramps but the entrance becomes congested during the rush hours business will probably be lost to the extent of cutting down, if not eliminating the profit altogether.

If the building is not large most of the ground floor will have to be given to receiving and discharging. Especially this is true if garage attendants do the parking; for there is always a time when cars come in faster than they can be parked and a liberal space must be set aside for temporarily parking this overflow.

If owners do their own parking much less entrance space is needed, three or four car lengths ahead of the checker's stand are needed as well as provision for cars to leave the incoming line at this point and pass to the exit in case the storage terms are not satis-

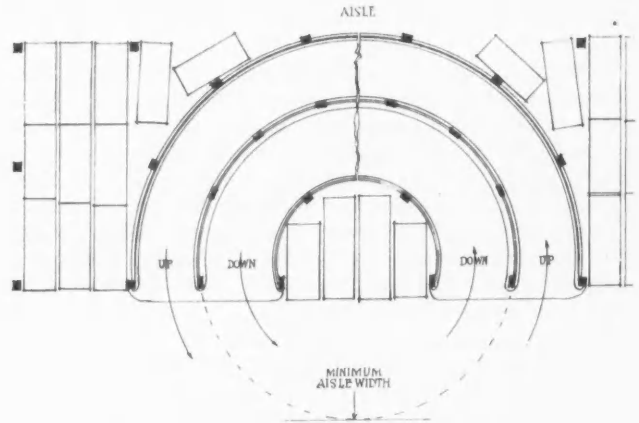

This Type of Ramp May Be Built in Two Ways. Construction is simpler if both runs are in the same helicoidal surface, but if they cross, one up and one down, the operation will be less hazardous, because the cars will always go in the same direction; there will be no aisle crossing.

factory. A waiting room is needed and it is usually profitable to have an accessory store in connection with the waiting room or at least very near it, for obvious reasons. Tire service, brake service, and gas and oil service are also entrance activities, because if visibly suggested to the customer and necessary, such service will be ordered during storage time. Gas and oil must not be given in the main entrance passage or exit unless these are wide enough for other cars to pass, sixteen to twenty feet each.

Working out a satisfactory large garage entrance, getting in all the desirable features and handicapped by the column arrangement necessary to make storage a success above, is one of the stiffest problems to be found and can only be worked out for each individual case.

Usually, too, if the building has an extensive and good street frontage it will be profitable to devote



The Gateway Garage, 56th St. and Stony Island Ave., Chicago; John Hocke, Architect.

this to stores which further cuts into the main floor and forces the entrance feature back into the interior.

A single entrance and a single exit are always best, for they conserve heat in winter; keep a better check on cars entering and leaving; avoid theft; and make it easier to sell the by-products mentioned above.

Passenger elevators and stairways are another difficult problem for they must be near the entrance on the main floor, although on the upper floors there are often "dead" corners which cannot be used for storage and which would take a stair shaft or an elevator shaft, possibly both, right up through all the floors. Where no such possibility exists, one or two storage spaces must be used. The staggered floor building is more difficult to handle because of the double number of floors, the elevator usually stops at the main floors and short stairways lead to the intervening floors, otherwise the elevator must have doors on two sides. In any case the elevator should be close to the dividing line of the floors.

The exterior treatment of the large garage is in all essentials the same as the office building; some are just as elaborate while others are quite plain brick or concrete facades with steel sashed windows.

General repairing is seldom an activity of the storage garage. Greasing, washing, brake testing and service, battery and tire service are the more common



The Gildred Garage, San Diego, Cal., W. Templeton Johnson, Architect; Wm. Simpson Construction Co., Builders.

services rendered and these are best on the main floor.

The garage with private stalls is a European practice, never made popular in this country, because of its greater expense and less efficiency.

Waiting rooms for both men and women and a special room for chauffeurs are all highly essential features of a large storage garage and should be equipped with telephone booths, toilets, and the chauffeurs' room should have an annunciator or other signaling device.

It is always well to plan the entrance for pedestrians so that the passage will lead them through the accessory store to the elevators and waiting rooms; sales result.

The architect or the builder who finds himself up against the problem of designing and building a storage garage, unless he has had experience is very likely to make serious mistakes; some do even with experience back of them. Garage men, as a rule, are not designers and every new problem is different. One who has had experience and knows the game can easily map out all the possibilities after which the best should be selected. The architect can then carry out the constructional and architectural details easily and surely.

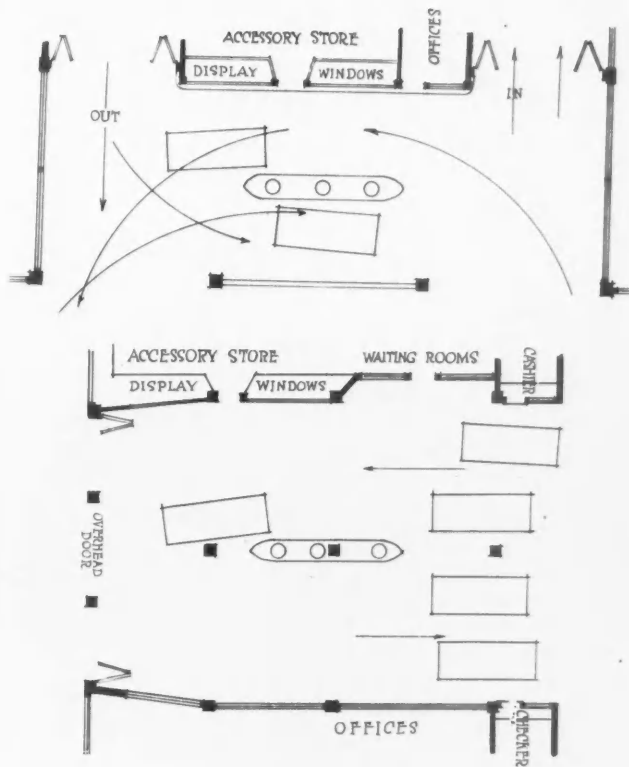

Two Typical Entrances Including Filling Stations That Will Give Gas Service Without Interfering Greatly with Coming and Going of Cars.



## Next Month HOTELS

James S. Warren, a recognized authority, will discuss Modern Hotels in the January "American Builder," continuing this valuable series.



# *A Sound Proof Studio Apartment*

TILLION & TILLION  
*Architects*



*Built  
to Interest  
Singers, Artists  
and Writers*

SHERMAN SQUARE STUDIOS, 160 West 73rd Street, New York City, was built in the belief that a high-class, sound-proofed apartment could be readily tenanted with professional people who are willing to pay for quiet in the noisy city.

In the beginning, it was planned to dispose of suites on the co-operative apartment basis, but this has been modified to a combination plan. For many of the tenants to whom the apartment appeals, the leasing plan seems to be most desirable.

The building is a steel fireproof structure designed with a series of setbacks from all sides, the masses of the structure gracefully building up until they terminate in a central tower. Setbacks provide space for tiled promenade terraces; and an open pergola and tiled roof garden are provided on the roof for the use of tenants.

The facade is of face brick, ornamented with stone and terra cotta. Yard and court walls are faced with light buff brick to insure maximum diffusion of light.

Sound-proofing is effected by an interesting process. In the floor construction a dry gypsum insulation substance was placed directly on the concrete sub-floors between sleepers. Rough floors followed by finished flooring was then laid on the sleepers. Like-

wise for the walls this insulation was placed between the studs after plaster board had been nailed on.

The basement contains a community kitchen. The heating plant is a vapor system of the most modern type. Suitable hot water storage tanks are provided to insure a continuous and ample supply of hot water.

A typical floor plan of the building is shown herewith. The first floor has four studio suites consisting of foyer or reception hall, studio, bath and service pantry, and four doctors' apartments consisting of office, secretary's room, waiting room, toilet and laboratory. There are two suites having a bedroom in addition to the above.

The second to twelfth floors each have four studio suites with bedrooms and seven suites without a bedroom. The thirteenth and fourteenth floors each have six studio suites with bedrooms and two suites with rest rooms, thus making a total of eighty-one studio suites without bedrooms, fifty-eight studio suites with bedrooms and four studio suites with rest rooms. Seventeen of the suites have private promenade terraces. Single rooms rent from \$1,200 to \$1,300 per year and two-room suites from \$2,100 to \$2,280.

The layout of rooms wherever possible has been so arranged that foyers, reception rooms, service pantries, bathrooms and bedrooms are located between the studio room proper and the public hall or the next adjoining studio. All doors between the suites and public halls are of an approved sound proof type. Between suites and public halls are double partitions with approved sound-proofing materials in the intervening space.



Detail of Entrance, Sherman Square Studios, W. 73rd St., New York.

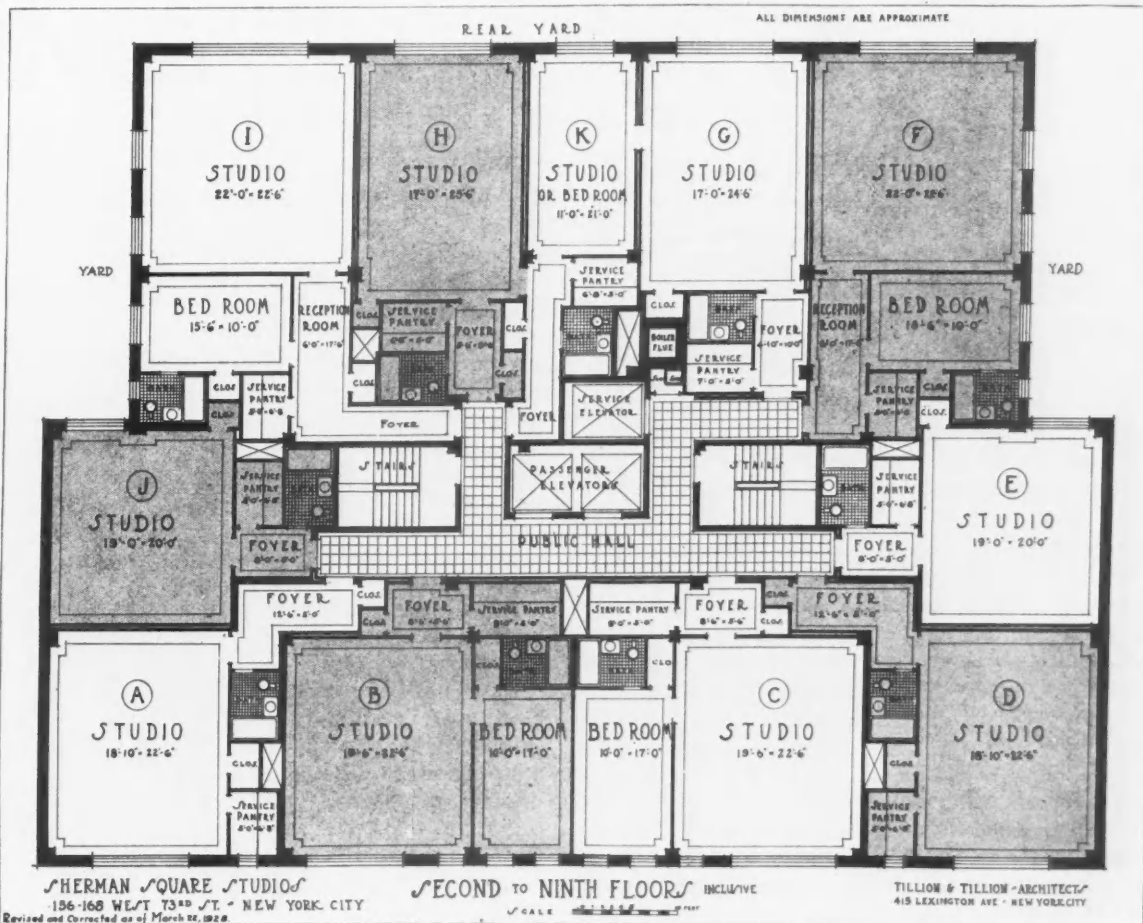

Interesting Layout of Studios and Apartments in the Sherman Square Building.

# The Conveniently Equipped



**Make Your  
Kitchens  
Attractive  
in Appearance  
and Scientific  
in Design**

**R**ESALE builders have shown me through many homes. Almost invariably the house itself is an index to the builder's mind. I have seen some remarkably fine houses but in very few cases were they as completely equipped as they could be; by that I mean having every item that makes for housekeeping comfort.

Here you can see the workings of the builder's mind, both as to what is there and what is not there, keeping a "weather eye," as it were, on his ultimate cost and selling price. It is perfectly proper that he should do this if he does it wisely. But I would like to call attention to the wonderful sales value of a *completely equipped* house—and especially a completely equipped kitchen.

For evidence of this we have only to turn to the hundreds of model homes built throughout the country. Not one of them, as far as I have been able to find out, has remained unsold; and most of them were sold before the demonstration period had run for more than a week or two. Nor could the selling price be considered prohibitive even with all these equipment costs added.

The kitchens of the electric model homes have, in most cases, contained the following equipment:

An electric refrigerator; an electric clock; fine lighting fixtures; an electric or gas range; a ventilating fan; kitchen cases and cabinets; vacuum cleaner closet; built-in ironing board; incinerator door; electric mixer; coffee grinder; electric dishwasher; or electric dishwasher sink; milk and package receiver. In addition there was usually tiled floor and wainscot and, lately, tiled sinks.

In designing a kitchen, of course, the first requisite is a scientifically arranged plan so laid out that all unnecessary steps by the housekeeper are eliminated. The kitchen may be compared to a factory or shop with the raw materials coming in at one end, moving along continuously through various assemblies to the finished product emerging on the shipping platform (in this case the dining table) without back-

travel or lost motion at any time on its journey.

As to the desirable size of the kitchen, Caroline Bartlett Crane, of Kalamazoo, Michigan, the eminent authority on house planning and domestic arrangements, makes the following interesting comment:

"A noticeable tendency, in the present high cost of building, is to contract the kitchen overmuch."

She then tells about a woman who fainted from lack of air while cooking in a small kitchenette, adding the doctor's exclamation:

"And they invent pet diminutives for this sort of thing. Kitchenette, indeed! Lethal chamber, I call it."

Doctor Crane's further comment is that this may be all right in an apartment building where only occasional breakfasts or luncheons are served for one or two people but, she adds:

"A real family kitchen is quite another affair."

A well designed kitchen is shown on page 86 by means of floor plan and elevations. This is an adaptation of one of the prize-winning plans in a recent nationwide competition, submitted by William D. Sherman, of Elizabeth, N. J.

Compactness is

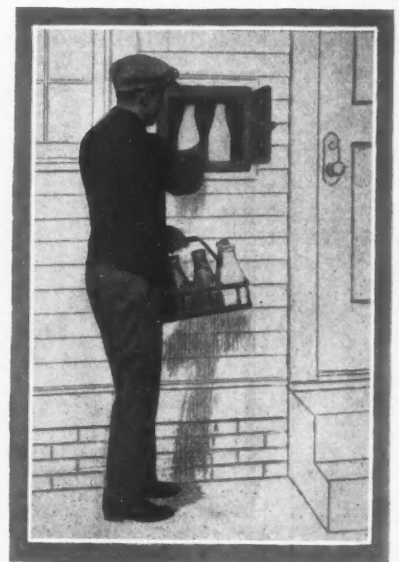

**Milk Receiver from  
Without.**



# Kitchens Help Builders Sell

**and Equip  
Them with  
Labor-Saving  
Conveniences**

Suggestions by  
E. A. Magurn

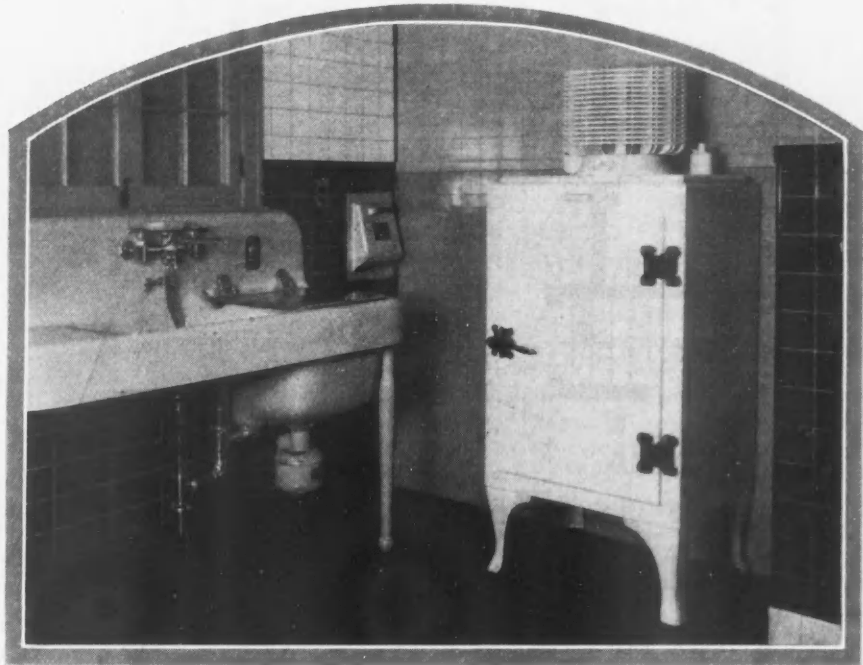

one of the essentials of a labor-saving kitchen, and, while the plan illustrated calls for dimensions of 13 feet by 14 feet 6 inches, the dimensions between the built-in equipment in the clear are only about 8½ feet by 11 feet.

Bearing in mind that north is towards the top of the plan, it will be noticed that the service door is towards the northwest. Alongside this doorway is a milk and package received, a convenience having considerable value to both deliveryman and housewife. It protects the milk from the hot sun in summer or from freezing and expanding out of the bottle in the winter. It also enables deliveries to be safely made when the family is away and the house locked.

In nearly all well designed kitchens, automatic refrigerators—gas or electric—are considered necessary to modern convenience. They are so well insulated that the heat of the kitchen has little effect on them and, being automatically regulated to maintain a low, even temperature, food storage is made sanitary and healthful. Food from the refrigerator goes to the kitchen cabinet, where cooking supplies are stored and, from there, to the sink past the cabinet containing the kitchen

dishes, beyond which is the cooking range. Or else it may take the opposite direction to the utensil storage and so to the kitchen range. This range is near the short hallway to the dining room and there is a handy table nearby. The passageway to the dining room is flanked by a breakfast nook on one side—the window side—and by a case for the storage of table dishes on the other. Beyond, is the swinging door to the dining room.

The location of the breakfast alcove is ideal, just off the kitchen and adjacent to an outside window. This breakfast nook also forms a convenient butler's pantry, with a handy table on which can be arranged the courses to be served at the main dining table.

The return routing for the dishes from the dining room is also well arranged, reaching directly a table and sink for convenient dishwashing and storage of dishes and utensils.

An architect or builder, in designing the kitchen, should look at it from the woman's point of view. Besides convenience, he must provide attractiveness—beauty.

In a recent article in the "Woman's Home Companion," Mrs. Anna Steese Richardson wrote: "Drudgery drove women out of the kitchen—now beauty is bringing them back again."

The kitchen is a room in which the housewife spends a large part of her time. She spends time in the kitchen that she would prefer to spend elsewhere in the house, if not away from home. For this reason, it certainly behooves the architect and builder to make the kitchen as cheerful and attractive as possible.

Kitchen cabinets have both beauty and convenience. And the manufactured units provide a perfection of cabinet work and special time and labor-saving conveniences which carpenter-built shelving, compartments and drawers cannot attain. The manufacturers use selected materials. All wood stock is carefully kiln-dried. The machine work is such as is obtainable only in the product of a properly



**Milk Receiver from  
Within.**

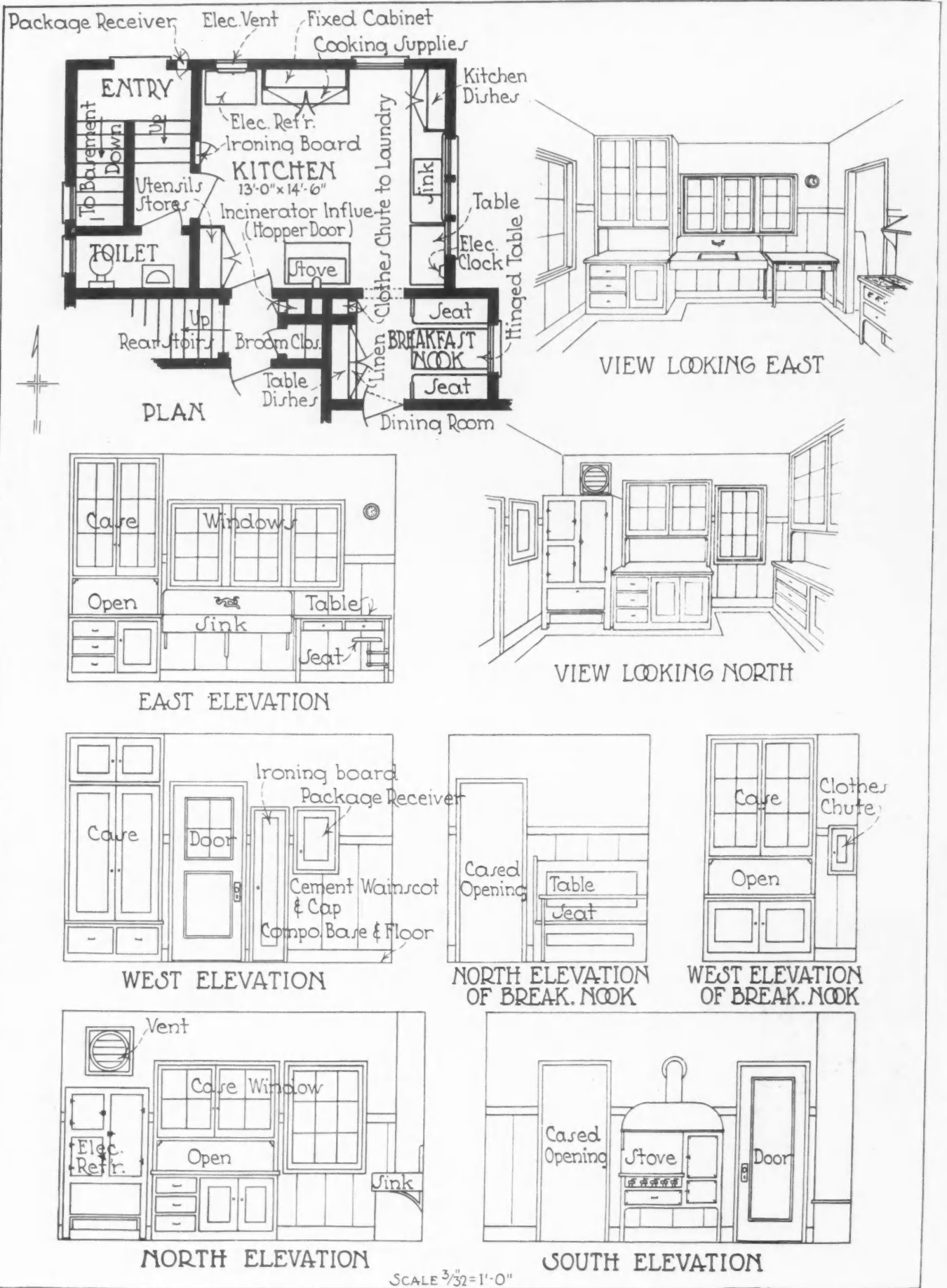

SCALE 3/32"=1'-0"

Architectural Suggestions for the Arrangement and Equipment of a Model Kitchen; Adapted from a Design by William D. Sherman.

equipped factory where careful work is turned out. Many builders prefer to install millwork cabinets which they can have shipped from a millwork house or delivered by the local lumber dealer as one of the items in a complete bill of material. By using millwork or carpenter-built cases and shelving, the

ing, in advance, detailed dimensions of every item usually obviate this difficulty. So far as cost is concerned, the factory or millwork equipment usually costs less—if quality and completeness are taken into consideration—than the carpenter-built equipment which is usually furnished.

Steel cabinets and cases have many advocates and many advantages, especially in apartment buildings where space is at a premium. Steel does not swell with moisture, nor warp. It is durable and permanent and can be beautifully finished. Attractive tints and colors are available in both wood and steel. Either steel or wood cases can be secured in units to be built in along the kitchen wall, expandable to any desired size and furnishing all manner of storage.

The bolting and assembly takes but a few minutes. In hospitals and institutions, steel cases are used almost exclusively and they are extensively used in apartment houses and hotels.

Steel combinations for kitchenettes are effective space-savers. These com-

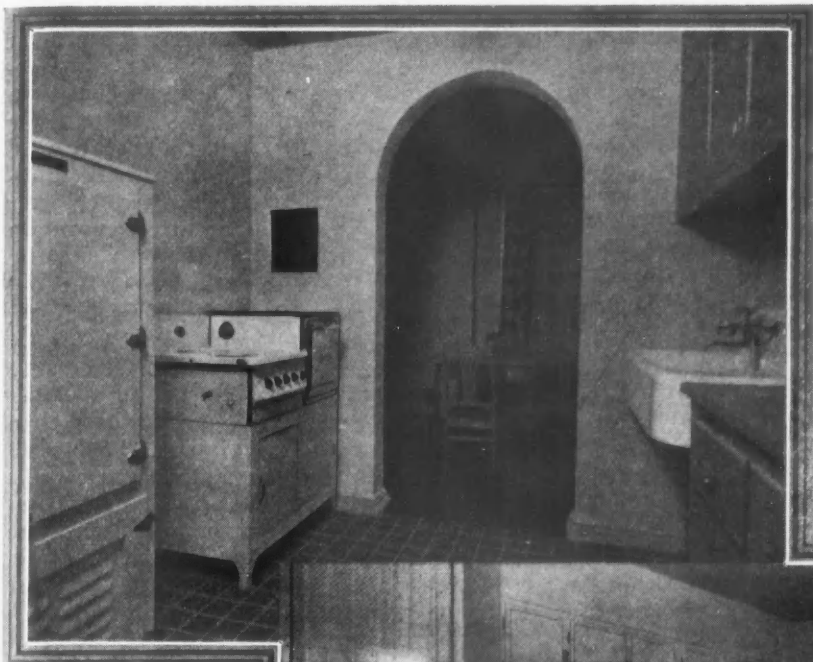

Above: One of the New Style Kitchen Ranges.

To Right: A Convenient Case Assembly.



Below: The Modern Kitchenette Is so Attractive It Needs no Separating Door to the Dining Room.

entire kitchen can be finished and decorated to a perfect match. From my observation in the field, I suspect that one reason why so many builders of individual homes prefer to build in their own cases and shelving is that—busy with so many pressing details—builders often fail to order factory built equipment or millwork sufficiently far in advance and fear that delivery delays may hold up their work. It is along the line of least resistance to finish up the kitchen with their own men and material when they come to it and avoid any chance of wrong measurements, interference or misfits. Carefully drawn kitchen plans show-





binations often include refrigerator, sink and gas or electric range in one unit with storage space below and shelving and cabinets above. French gray, turquoise blue, old ivory, apple green are some of the color combinations which add beauty to any kitchen.

As cookery is the chief function of a kitchen, no piece of equipment in the kitchen is more important than the cooking range. To some builders, a gas range is a gas range but, if they will consider the subject from the feminine point of view, they will find that any but the highest quality gas ranges are junk. Nowadays, a woman recognizes a cheap, poor range as far as she can see it. Consequently, a builder cannot afford to install one of that kind. On the other hand, the woman of today is quick to recognize superior merit in a range. She knows the value of good insulation, heavy, well joined metal, convenient, ample design, good nickel plate and the fine appearance of tinted porcelain finish. In fact, to a mere man, it is surprising how greatly women value the fine appearance which the best manufacturers are imparting to modern ranges.

A striking innovation in gas ranges has recently been brought out by one of the manufacturers. It has a number of improvements in design and construction but the most striking innovation is the appearance of this range. It has a hinged and counter-balanced top which closes down flush with the oven when the burners are not in use. The range is finished to resemble marble, which gives it the appearance of a fine piece of furniture.

One of the richest in the choice of finishes is similar to a black veined marble, called Italian Grand Antique. Onyx green bakelite handles suspended from an ornamental design add greatly to the attractive appearance of this kitchen piece. Another color combination furnished is ivory with apple green trim.

Set in a tiled kitchen with harmonizing colors, this range resembles a stove less than it does a fine radio. While a stove of this type would be out of place in a small, inexpensive home, it would be wonderfully attractive in its proper setting.

The electric range is coming into greater favor every year, especially where the cost of electric current is low. Cities like Buffalo, Toronto, Los Angeles and San Francisco have hydro-electric current at from 2½ cents to 3½ cents per K. W. hour and electric ranges in such cities operate at a lower cost than gas. Even in places like Kansas City, where there is no hydro-electric current, electric ranges are said to operate at a lower cost in large apartment buildings than do gas ranges. This is due to the lower rates earned by the increased electrical consumption where the apartments are equipped with electric ranges.

In the "Alps" Apartment Building, Kansas City, which has 82 apartments, electricity is paid for by the owners. The average monthly cost for electricity has been \$526.10, including current for lights, elevators, refrigerators and electric ranges, or less than \$6.26 per month per apartment. Had gas been used for cooking, the combined gas and electric bills would have been much higher, as proved by a comparison with a 75-apartment building in the same city. In this latter building, during the same period, there were 13 apartments vacant and the cost for gas and electricity averaged \$2.64 more per month per apartment than it did at the "Alps." The most significant fact, however, to my mind, is the heavy percentage of vacant apartments in the one building and none in the other, demonstrating the attractiveness to tenants of the modern electrical equipment. Electric cooking is clean, safe and economical and the heat can be controlled to a nicety.

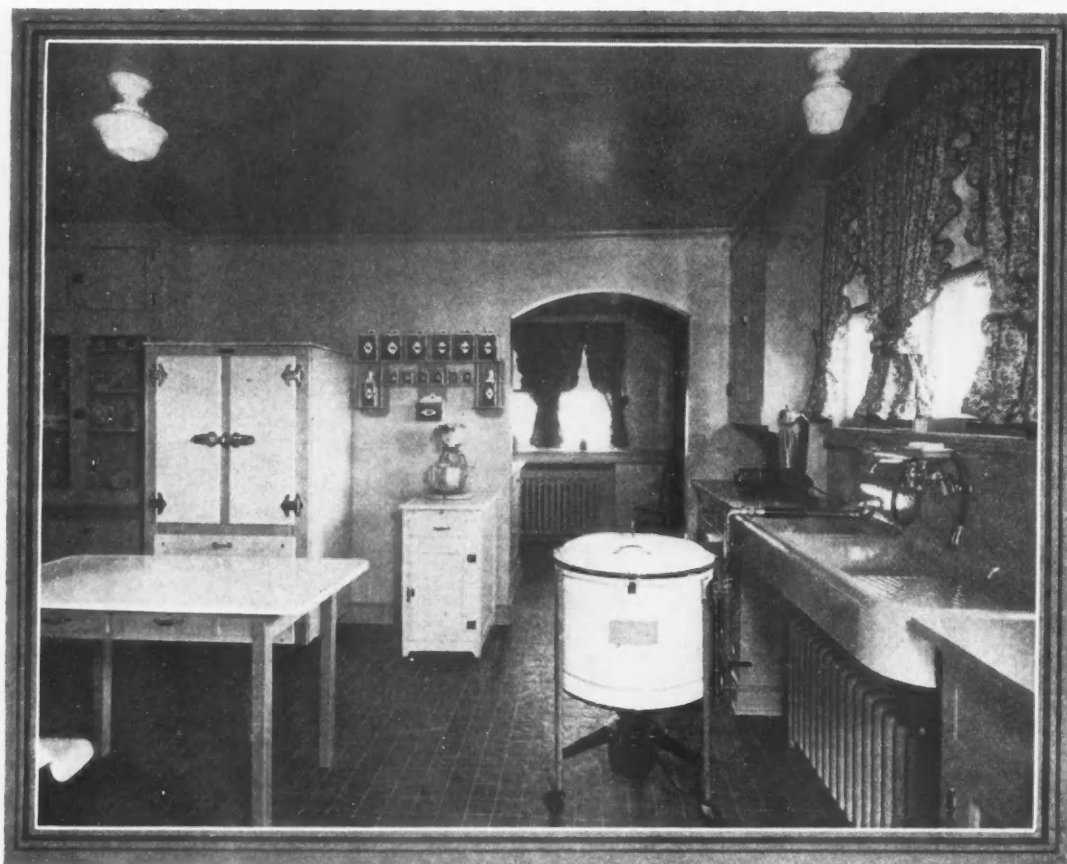

**A Model Kitchen  
with All the Special  
Features  
Which Make for  
Quick Sales**

, this  
radio.  
nce in  
rfully

favor  
cur-  
nge-  
nt at  
elec-  
than  
here  
said  
uild-  
ower  
tion  
etric

City,  
by  
city  
ele-  
han  
used  
bills  
om-  
me  
od,  
for  
nth  
ost  
ivy  
ing  
ve-  
nt.  
nd

n  
e-  
s  
r



*A Ground Breaking  
Ceremony*

# Model Homes in Cleveland

*Successful Campaign of the Cleveland Better Homes Assn.*

By H. P. BOYNTON

**T**HE Cleveland Better Homes Assn. has just completed its second Educational Model Home Campaign with gratifying results. Six homes were built under the auspices of the Association. They were completely furnished and displayed for periods of three weeks each and promptly sold.

The Better Homes Association represents a reorganization of the older Build a Home First movement, embracing now not only model home activity, but home modernizing and a home service bureau at which plans of low priced homes and impartial building council are provided at nominal cost.

The Educational Model Home campaign just closed was conducted under a plan by which the development company assumed the position of owner with the association nominating the architect, approving the plans, negotiating material concessions and handling the publicity. Concessions in the price of materials were for the benefit of the developer who, in turn, contributed a fixed sum per home to the treasury of the association.

Six different Cleveland suburbs were each the site of an Educational Model Home operation, as follows:

- Euclid, Indian Hills of the Indian Hills Estates Co., Fox, Duthie & Foose, architects.
- South Euclid, Belvoir Green of the A. R. Phillips Co., Maier & Walsh, architects.
- Maple Heights, The Maple Heights Development of The Crawford Land Co., Charles R. Greco, architect.
- Parma, The Brookview Development of The Klein-Lampl Homesite Co., Bohnard & Parsson, architects.
- Parma Heights, Eureka Park of The Parma Heights Development Co., Philo R. Brooke, architect.
- Fairview, The Fairview Golflands Development of The Maerke, White, Huxtable, Auble Co., George Hunt Ingraham, architect.

The association appealed to the Cleveland Chapter of the American Institute of Architects and interested

it in the question of better architectural character for the average street. With the sanction of the National Institute, the Chapter entered heartily into cooperation with The Better Homes Association, on the score of public service, and there was no lack of volunteers among the best architectural firms of the city to take charge of the various model homes, including plans and complete supervision for the customary fee of six per cent, which would not have been an inducement but for the character of public service which attached to their efforts.

Developers were chosen after questionnaires had been submitted to a large number of applicants. Some 30 development organizations responded and selection was made on several grounds: (1) accessibility, (2) good development, (3) complete improvements, preferably fully paid for, (4) moderate prices within a range which permitted complete properties to be sold for \$10,000 to \$14,000, (5) moderate tax assessments, (6) reputation for skillful handling of development properties and conscientious regard for agreements, (7) territorial distribution.

Sunday crowds at the various homes varied from less than 100 up to 2,000 per Sunday, according to weather and circumstances. The more interested prospects came back on week day evenings, and it was then that a major part of the actual sales work was accomplished. Exterior illumination by flood lights helped.

The Better Homes Association of Cleveland is officered by George Donley, president, Mills G. Clark, Frank Aulenbacher and Arch C. Klumph, vice-presidents—E. A. Roberts is secretary and W. E. Roe, a banker, treasurer. The direction of home building activities, initiated two years ago by Don A. Loftus, has largely passed into the hands of A. E. Avery, plumbing supply dealer, who is this year the efficient chairman of the Model Homes Committee.



INDIAN HILLS ESTATES COMPANY, Builders

FOX, DUTHIE and FOSSE, Architects, Cleveland, Ohio

## A COLONIAL IN BRICK VENEER

*A Demonstration Home in the Indian Hills Development, Cleveland, Ohio. One of the Cleveland Better Homes Campaign Houses. Cost \$15,050.00, with site*

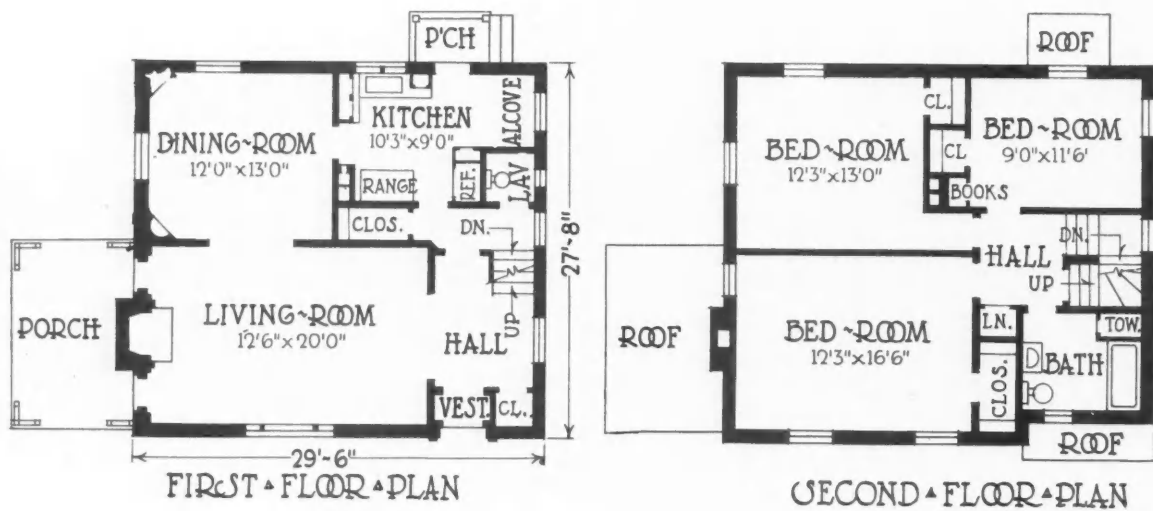





A. R. PHILLIPS COMPANY, Builders

MAIER and WALSH, Architects, Cleveland, Ohio

# SHINGLED WALLS ARE PLEASING

*Another Cleveland Better Homes Campaign Demonstration House in the Belvoir-Green Development, Costing \$15,718.00*

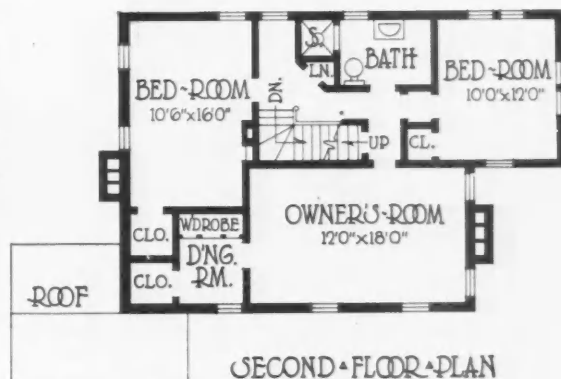
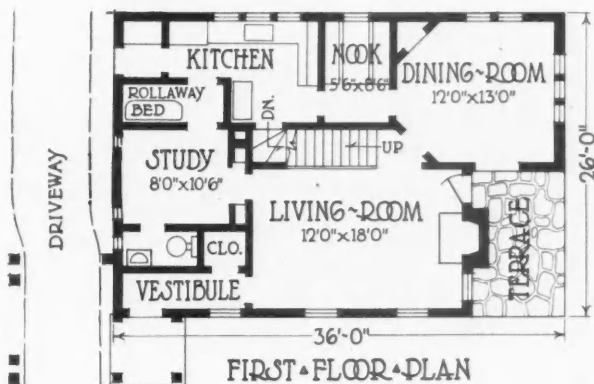

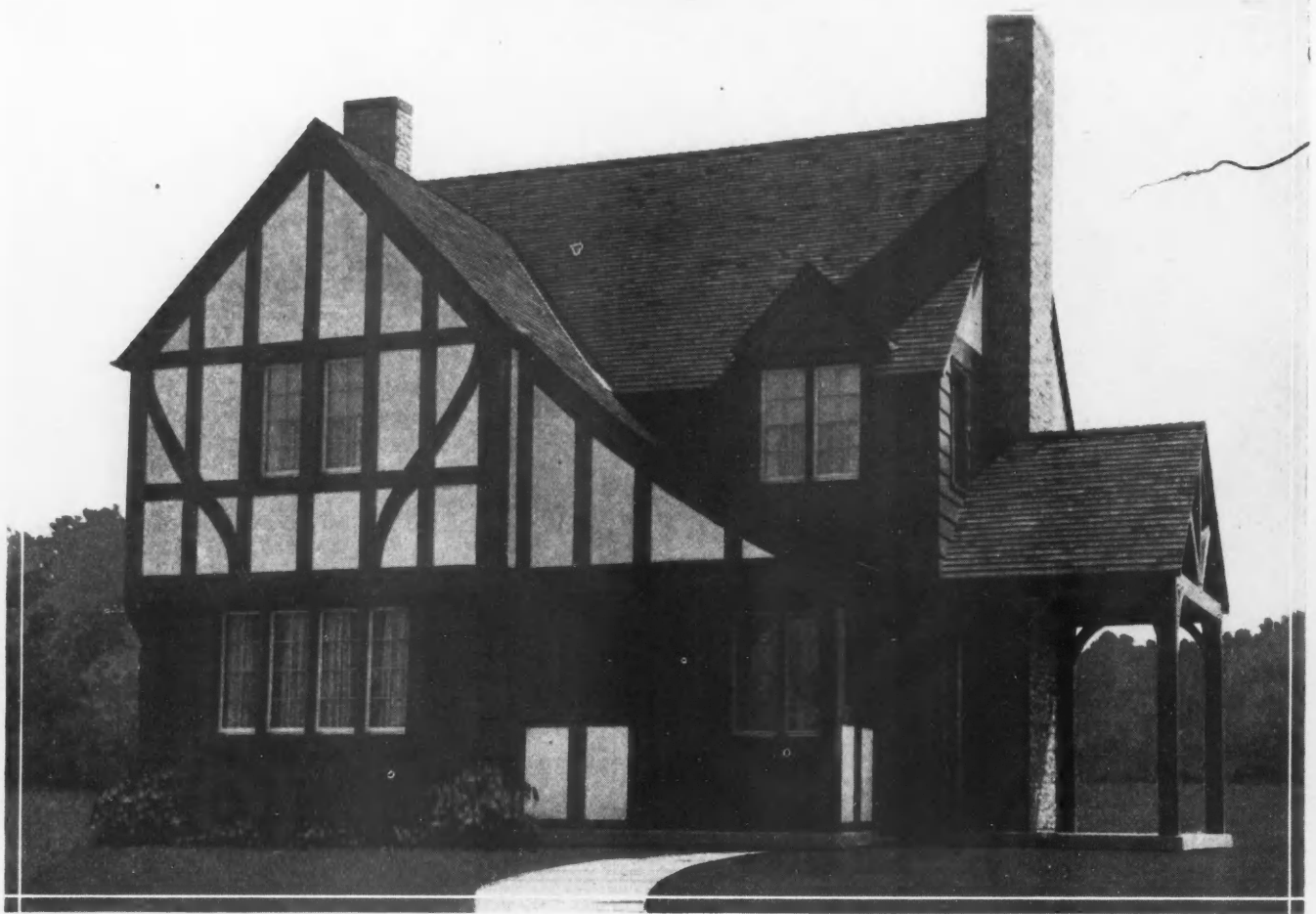

CRAWFORD LAND COMPANY, Builders

CHARLES R. GRECO, Architect, Cleveland, Ohio

# FRAME *and* HALF-TIMBERED STUCCO

*Built in the Maple Heights Subdivision as a Part of the Cleveland Better Homes Campaign at a Cost of \$11,122.00*

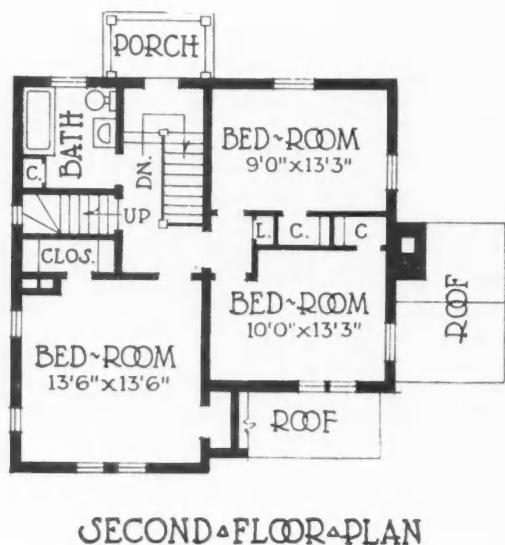
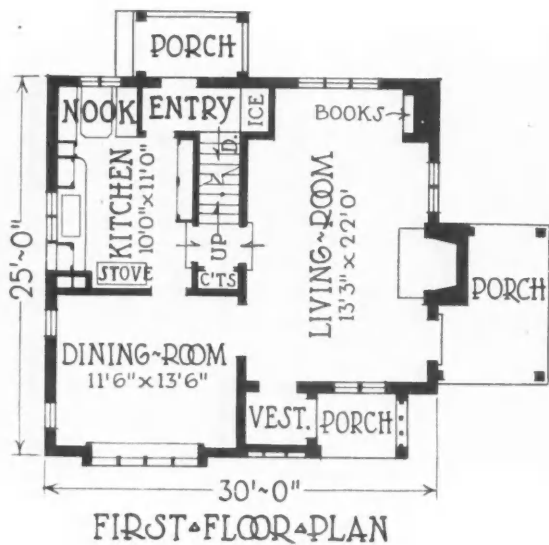



KLEIN-LAMPL HOMESITE COMPANY, Builders

BOHNARD and PARSSON, Architects, Cleveland, Ohio

# A HANDSOME BRICK RESIDENCE

*Brick Over Clay Tile But Costing Only \$11,985.42 When Built in the Brookview Development as a part of the Cleveland Better Homes Campaign*

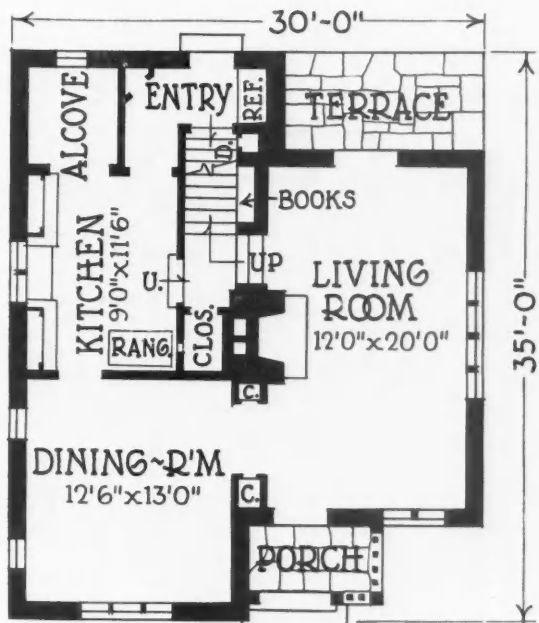

FIRST FLOOR PLAN



SECOND FLOOR PLAN





PARMA HEIGHTS DEVELOPMENT COMPANY Builders

PHILO R. BROOKE, Architect, Cleveland, Ohio

# DONE IN DUTCH COLONIAL STYLE

*A Unit in the Cleveland Better Homes Campaign Demonstration Built at Eureka Park at a Cost of \$11,581.00*

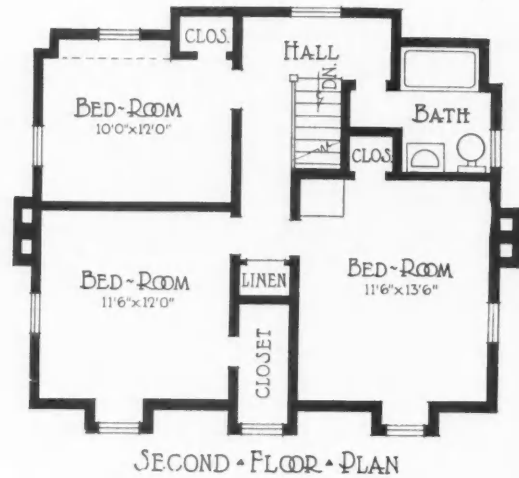



MAERKLE, WHITE, HUXTABLE, AUBLE COMPANY, Builders

GEORGE HUNT INGRAHAM, Architect, Cleveland, Ohio

# COLONIAL DIGNITY IN EVERY LINE

*A Fairview Golflands Home Built in the 1929  
Cleveland Better Homes Campaign. Cost \$10,610.10*

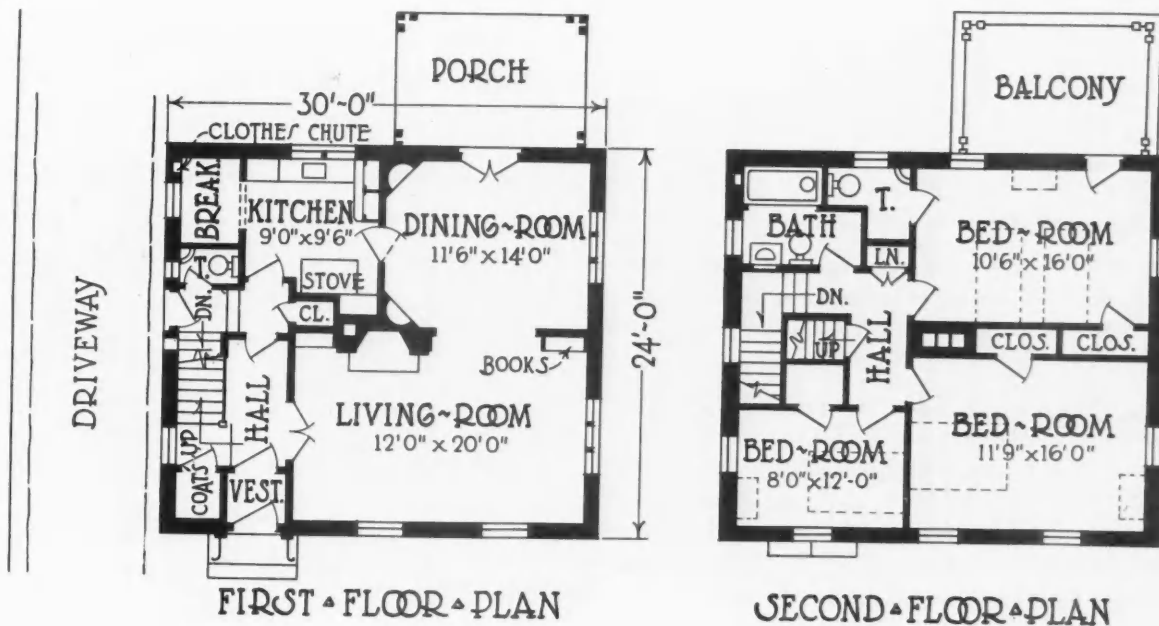



## DISTINCTIVE AND APPEALING

*This Home Stands Out in Any Group Though  
Blessed with the Permanent Value of Simplicity*

### SERVICE TO HOME BUILDERS

*Throughout this magazine we present many building designs. A variety of home plans are included, selected from many parts of the United States and designed by various architects of standing.*

*The "American Builder" will gladly serve its readers by bringing them together with these architects if any further information or plans are desired for any of these designs. Address the American Builder Home Planning Service, 105 West Adams Street, Chicago, or 30 Church Street, New York City.*

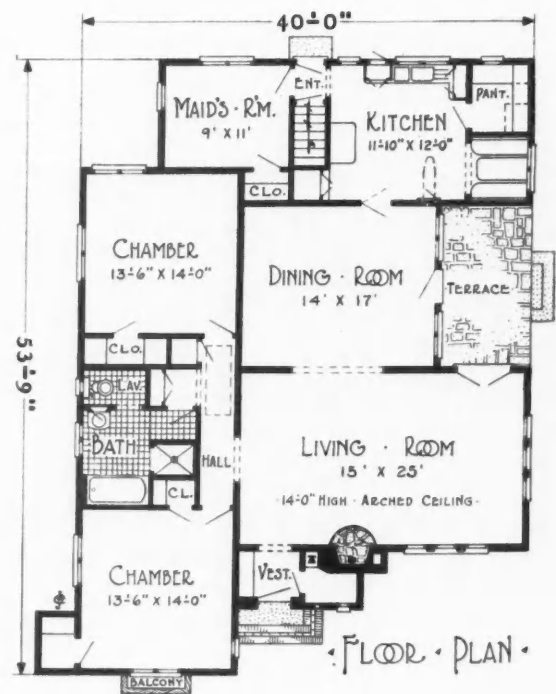





# A CHARMING COTTAGE HOME

*That Powerful Appeal Summed Up in the Word Home-like Is the Instant Impression from This Design*

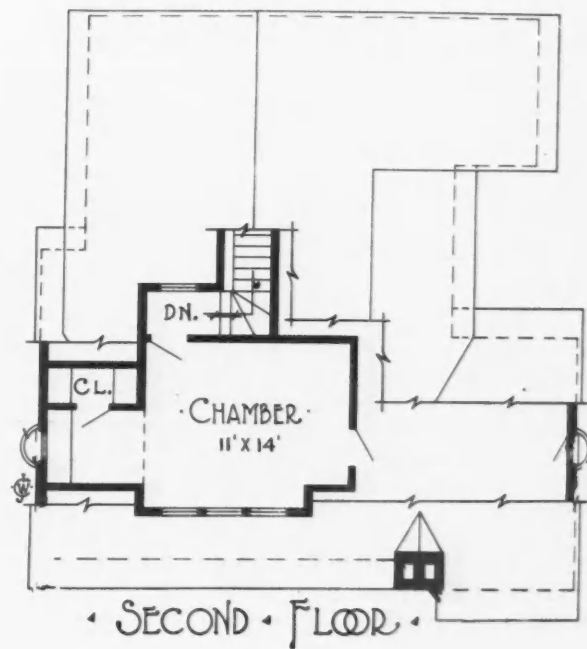
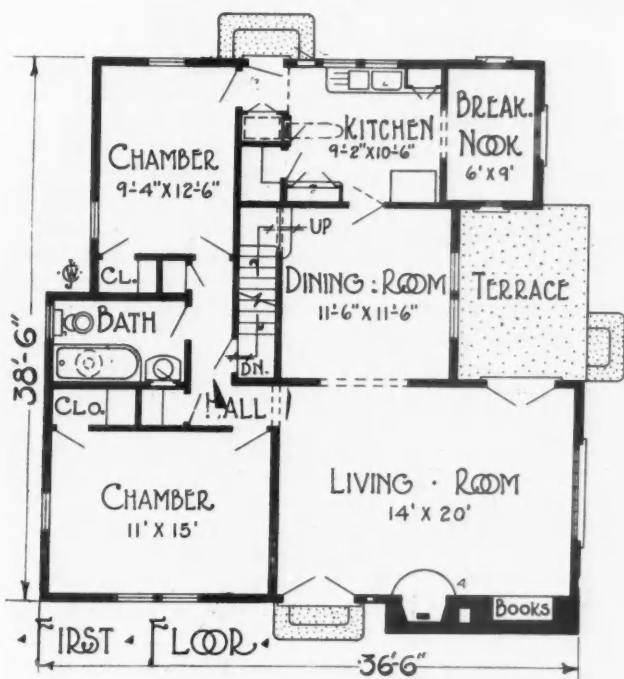



THE AMERICAN BUILDER ALL-FEATURE HOME

## Complete Working Plans

*A Popular Modern Brick Bungalow Presented in  
One-Eighth-Inch Scale Drawings*

**P**OPULAR demand has dictated the design of the house illustrated on this page. It has been developed, by the AMERICAN BUILDER architectural staff, not only as a home of pleasing exterior appearance, but as a home measuring up to certain standards determined by a study of what the home buying public wants.

Although a two-story house is less expensive to build than a one-story house with the same floor space, it still remains a fact that, for the smaller homes of six rooms or less, the bungalow is more popular than the two-story house. On the four pages which follow, then, are presented complete working plans and elevations for a bungalow home. The builder can work directly from these or use them as a basis to adapt the design to special requirements, meeting this popular demand.

The solid brick walls, on concrete foundations, may be either of face brick or of common brick, skintled. The effect in either

case, with a well selected roofing material, would be equally pleasing and would meet the building code requirements of any city.

While the floor plan is one which could be adapted easily to special requirements it will be found very satisfactory for the average family with little or no alteration. The bedrooms are well separated from the living rooms while the whole arrangement is compact and convenient. The housewife will find the arrangement one which demands a minimum of steps during the day's work.

The basement plan, on the next page, shows the laundry equipment all placed at one side and the heating plant and water heater in one corner, leaving a large amount of space for the accommodation of basement rooms in accordance with the modern idea of utilization of basement space.

A conspicuous feature of this design is the provision of numerous items of equipment which make a house salable.

### NEXT MONTH

Complete Plans of Colonial  
Home with Side Walls Finished  
with Cedar Shakes





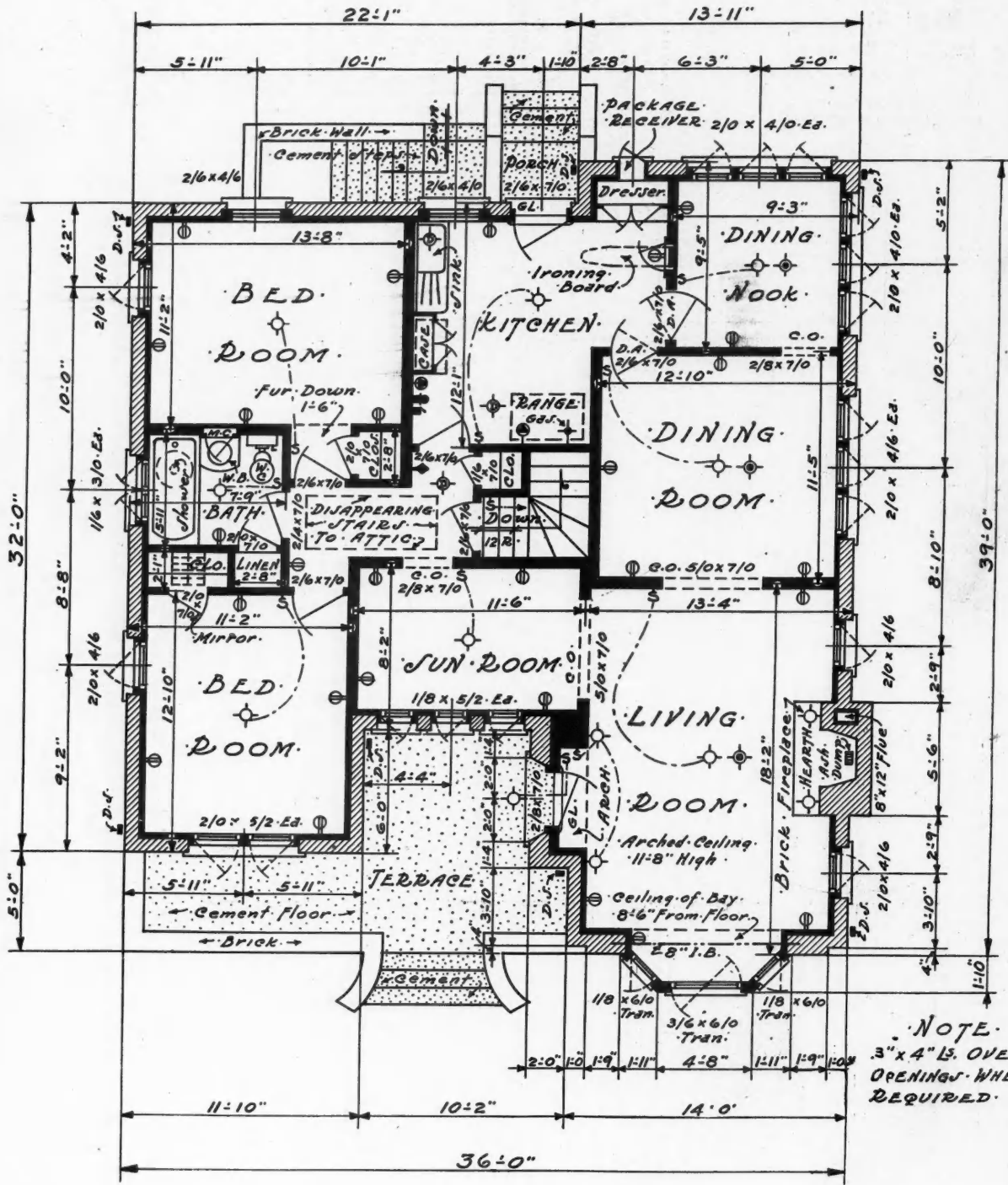

FLOOR PLAN

SHEET No. 2

SCALE 1/8" = 1'-0"

This Floor Plan of the All-Feature Home Shows a Remarkably Convenient Arrangement of Rooms and Complete Modern Equipment.

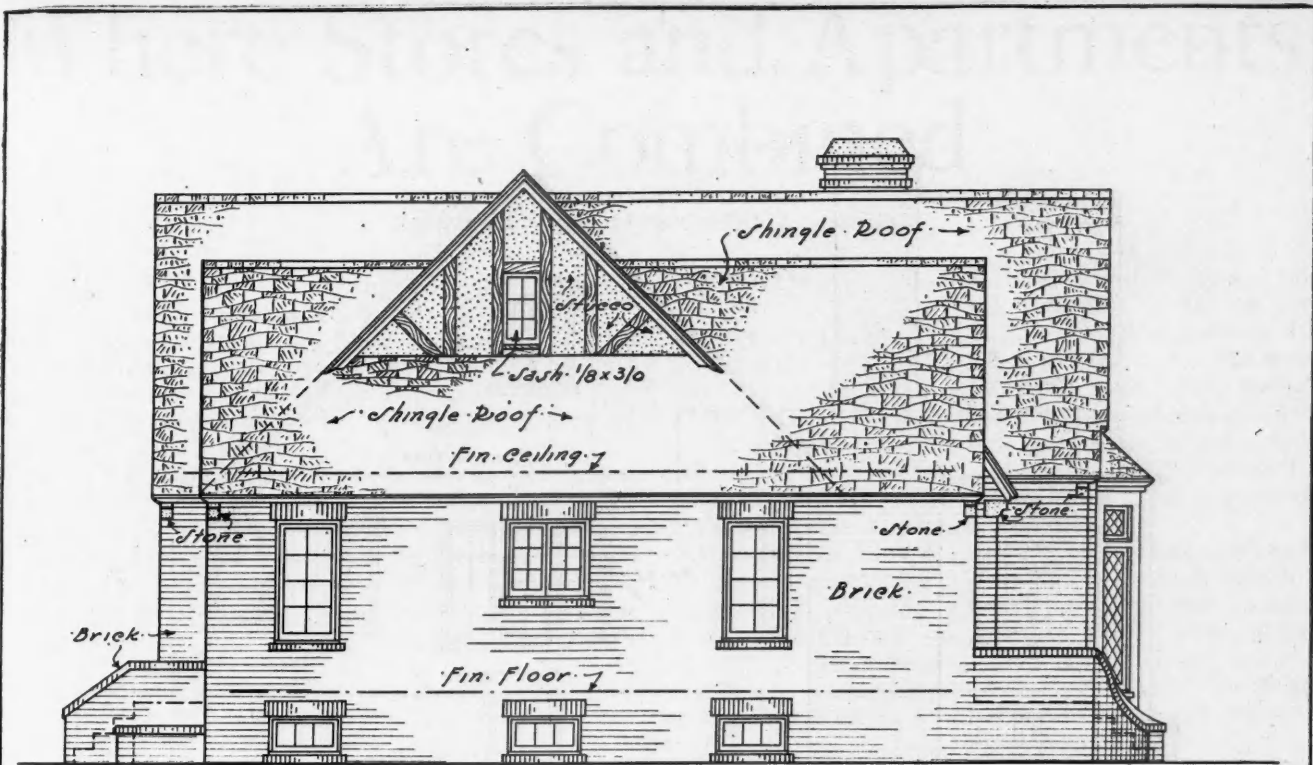

• LEFT • SIDE • ELEVATION •

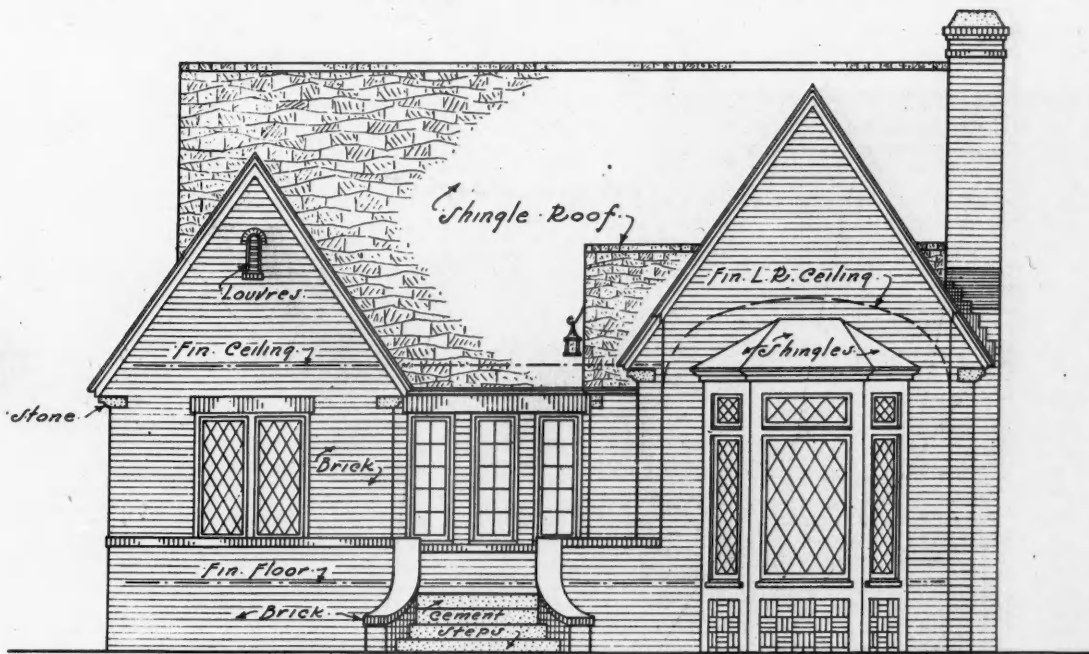

• FRONT • ELEVATION •

• SHEET • No. • 3 •

• SCALE • 1/8" = 1'-0" •

Either Face Brick or Skintled Common Brick Can Be Used to Good Effect to Produce a Home of Attractive Appearance When Viewed from Any Side.

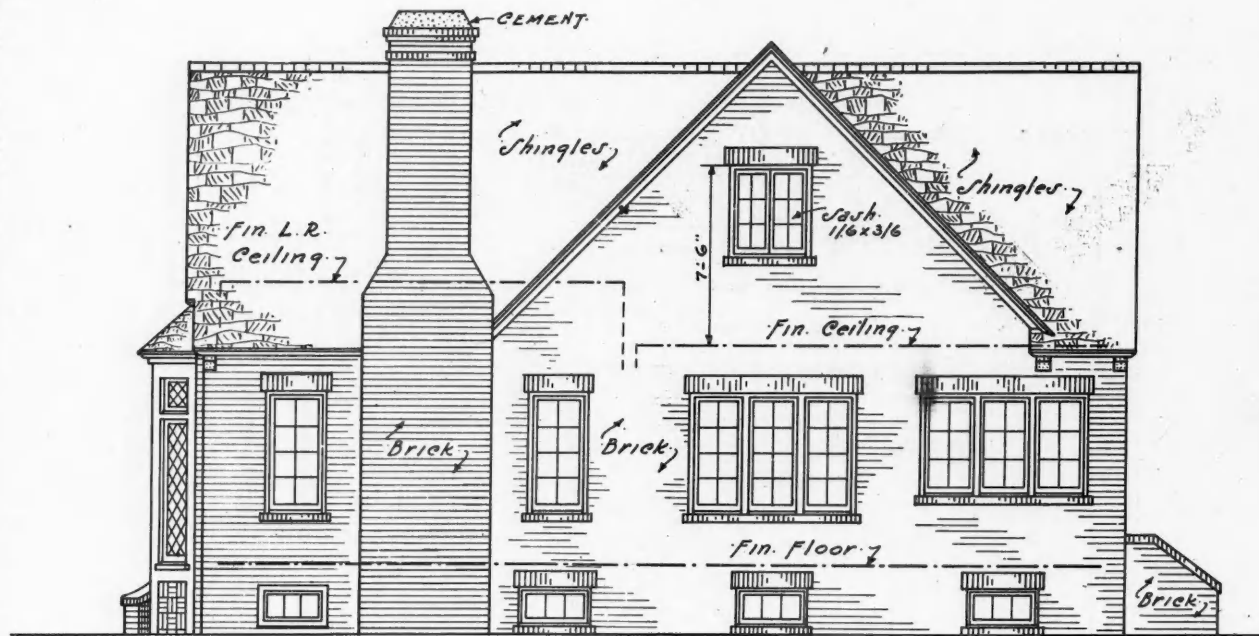

• RIGHT • SIDE • ELEVATION •

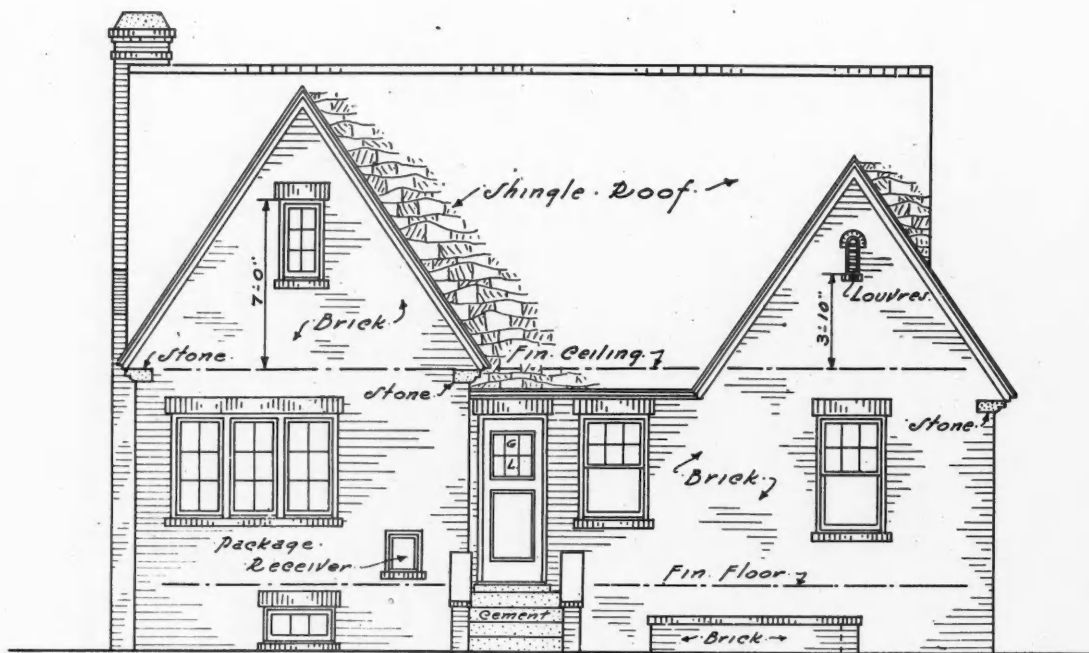

• REAR • ELEVATION •

• SHEET • N<sup>o</sup> • 4 •

• SCALE • 1/8" = 1'-0" •

Not Only Is the All-Feature Home Attractive to Look at from Every Angle. But It Meets the Popular Demand for Small Bungalow Homes.

W

B  
and m  
more  
lends  
this p  
Loc  
Avenu  
buildi  
comm  
develo  
and H  
design



# Where Stores and Apartments Are Combined

RISSMAN AND HIRSCHFELD, *Architects*

**B**UILDINGS in which stores and apartments are combined have become an increasingly important factor in the general building scheme and many builders are being called upon more and more frequently for this type of work. This fact lends greater interest to the building illustrated on this page.

Located at the diagonal intersection of Milwaukee Avenue and Diversey Boulevard, in Chicago, the building site offered an excellent opportunity for a community store and apartment or kitchenette hotel development. The design, worked out by Rissman and Hirschfeld, Architects, affords a standard for designers in this field of construction.

The entire first floor is used for store space, taking full advantage of the two fine fronts on two main thoroughfares. On the two floors above 100 kitchenette apartments are provided. For the most part these apartments follow a fixed plan, though a few have been provided with an additional bedroom. The court space, enclosed with the triangular layout, assures excellent light and ventilation for every apartment, at the same time making economical use of the available space.

The typical floor plan of an individual apartment shows a large living room, at one end of which a complete kitchenette is built into a cabinet, making it readily accessible but entirely hidden when not in

use. At one side of the living room a disappearing bed is concealed by doors which also give access to a large dressing closet and the bathroom.

This plan is typical of the modern ultra-compact apartment which provides a complete home within the smallest possible space. It is interesting to note that this type of apartment has been made possible only through the development of built-in and compact equipment which has been carried to such a high point in recent years by the equipment manufacturers.

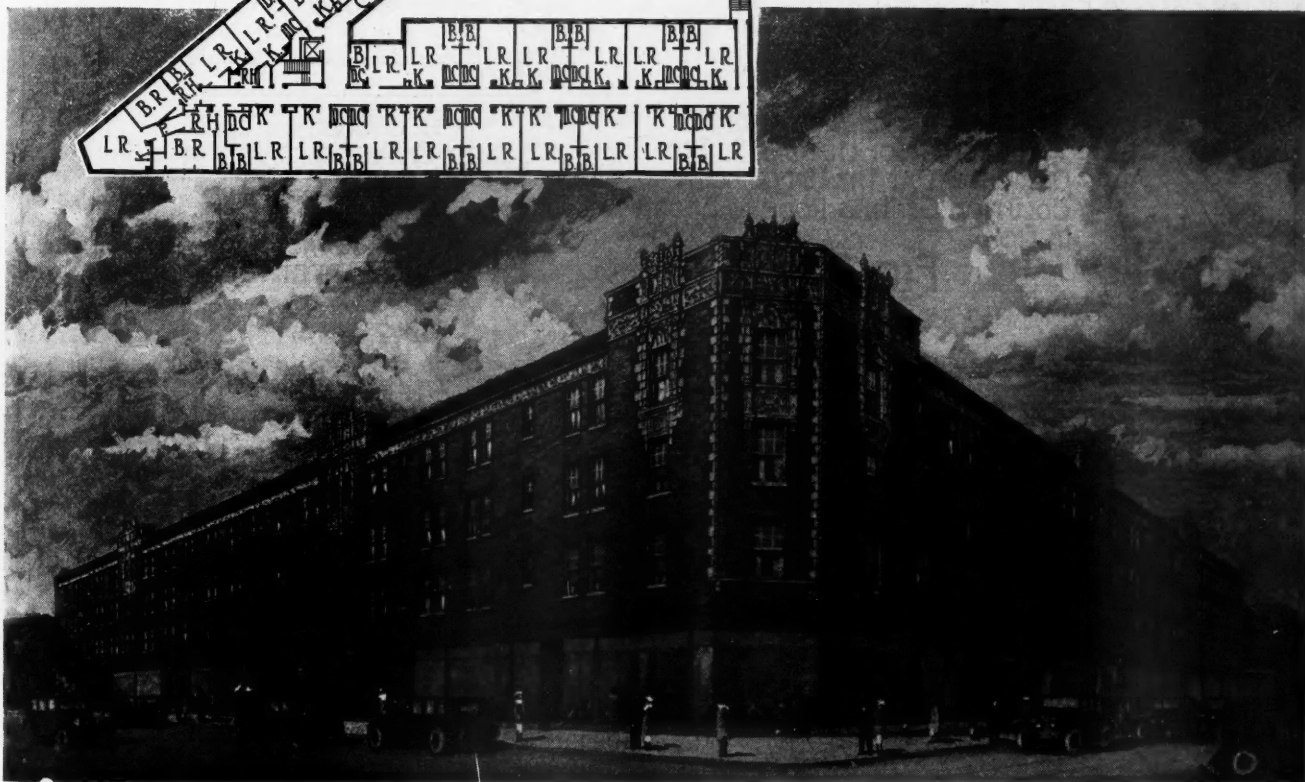
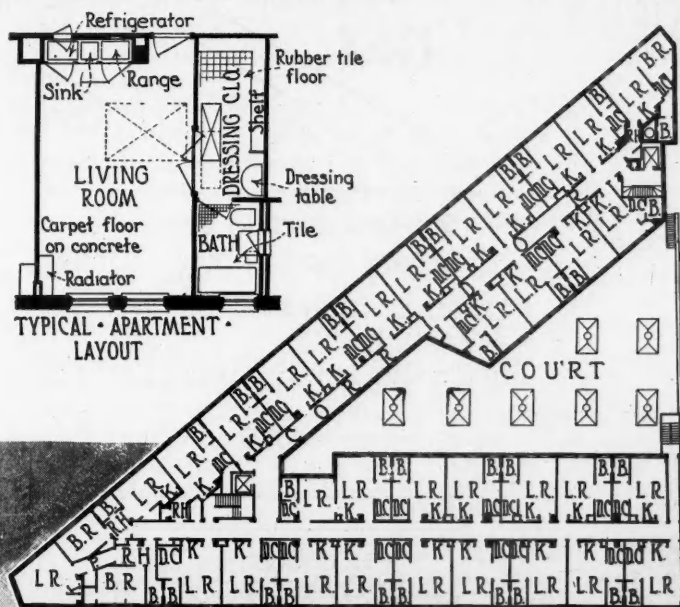

The Ultra-Compact Kitchenette Apartment Is Particularly Appropriate in the Building Where Stores and Apartments Are Combined. Rissman and Hirschfeld, Architects.

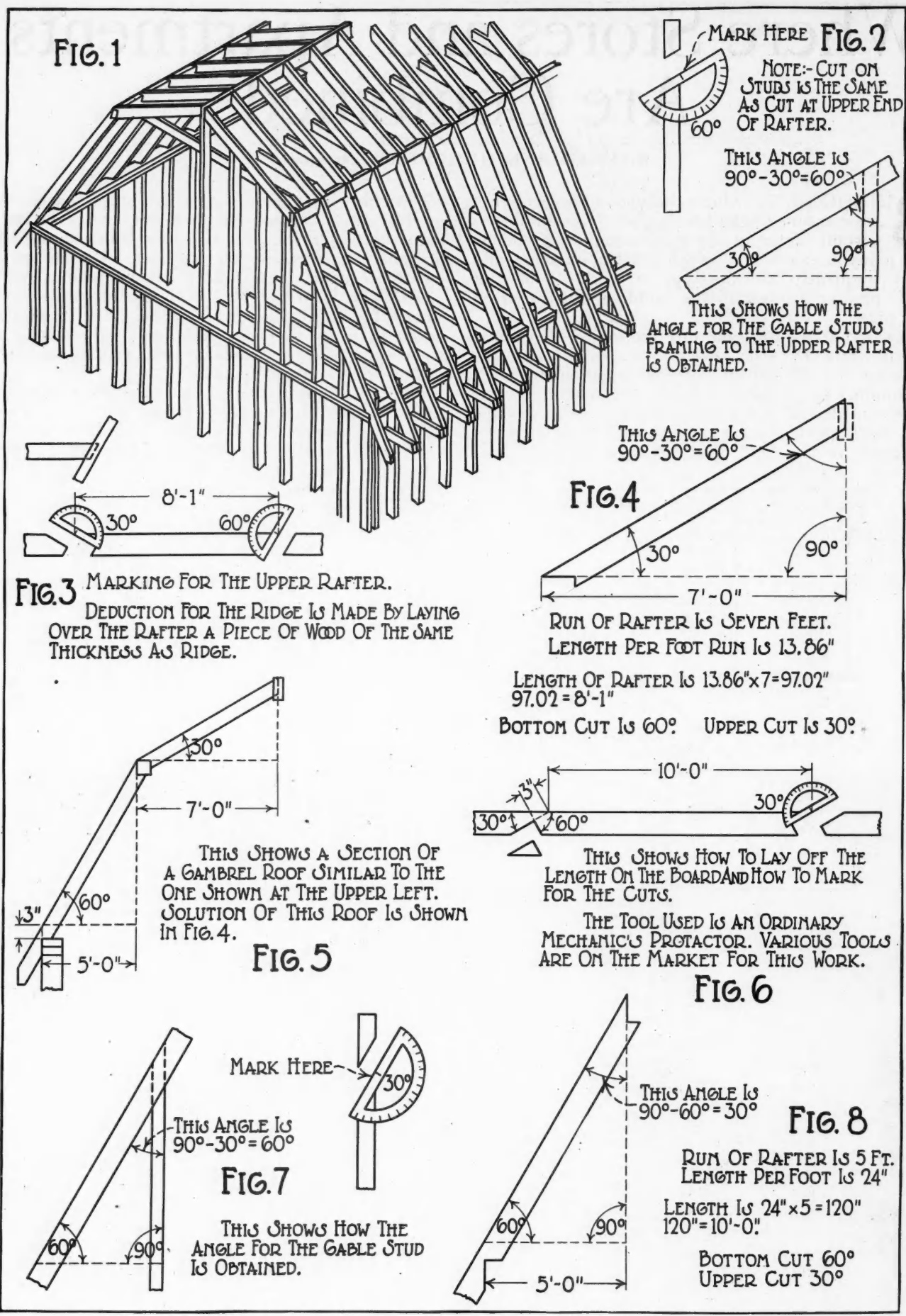

FIG. 1

MARK HERE FIG. 2

NOTE:- CUT ON STUDS IS THE SAME AS CUT AT UPPER END OF RAFTER.

THIS ANGLE IS  $90^\circ - 30^\circ = 60^\circ$

THIS SHOWS HOW THE ANGLE FOR THE GABLE STUDS FRAMING TO THE UPPER RAFTER IS OBTAINED.

THIS ANGLE IS  $90^\circ - 30^\circ = 60^\circ$

FIG. 4

RUN OF RAFTER IS SEVEN FEET. LENGTH PER FOOT RUN IS 13.86"

LENGTH OF RAFTER IS  $13.86 \times 7 = 97.02$ "  
 $97.02 = 8'-1"$

BOTTOM CUT IS  $60^\circ$  UPPER CUT IS  $30^\circ$

FIG. 3 MARKING FOR THE UPPER RAFTER.

DEDUCTION FOR THE RIDGE IS MADE BY LAYING OVER THE RAFTER A PIECE OF WOOD OF THE SAME THICKNESS AS RIDGE.

THIS SHOWS A SECTION OF A GAMBREL ROOF SIMILAR TO THE ONE SHOWN AT THE UPPER LEFT. SOLUTION OF THIS ROOF IS SHOWN IN FIG. 4.

FIG. 5

THIS SHOWS HOW TO LAY OFF THE LENGTH ON THE BOARD AND HOW TO MARK FOR THE CUTS.

THE TOOL USED IS AN ORDINARY MECHANIC'S PROTRACTOR. VARIOUS TOOLS ARE ON THE MARKET FOR THIS WORK.

FIG. 6

MARK HERE

THIS ANGLE IS  $90^\circ - 30^\circ = 60^\circ$

FIG. 7

THIS SHOWS HOW THE ANGLE FOR THE GABLE STUD IS OBTAINED.

THIS ANGLE IS  $90^\circ - 60^\circ = 30^\circ$

FIG. 8

RUN OF RAFTER IS 5 FT. LENGTH PER FOOT IS 24"

LENGTH IS  $24 \times 5 = 120$ "  
 $120 = 10'-0"$

BOTTOM CUT  $60^\circ$  UPPER CUT  $30^\circ$

Diagrams to Make Clear the Measurements and Cuts for a Gambrel Roof.

The line story. On pitch are any revic the seen for t W and give St Ever sket alrea solv of th T both Figu raffe for alwa is 45 two angl 24 = T foot in fe the T We pitch calc R Pitch Degree 85 80 75 70 65 60 55 50 45 40 35 30 25 20 15 10 5

# Framing the Gambrel Roof

Continuing Our Course of Roof Framing Simplified—  
Diagrams on Page Opposite

By JOHN T. NEUFELD

THE illustration at the upper left hand corner of the page opposite is a typical detail for a gambrel roof, as used in house construction. The second story is usually built into the roof, the line of the purlin forming the ceiling of the second story.

Our two previous discussions have dealt with the pitch of a roof and other elementary points which are essential to know in order to be able to frame any roof. The last lesson especially should be reviewed as it showed the various ways of finding the length of a rafter. The writer has never before seen the various methods, all put side by side, and for that reason we urge you to review this lesson.

We shall now by the aid of a table find the lengths and cuts for all the rafters of a gambrel roof, as given in Figure 5.

Stating a problem definitely is half the problem. Even so in roof framing a problem should be sketched out so that you know what information you already possess and what information you have to solve for. In this case we have the run and the pitch of the rafter given.

The next step then would be to find the cuts at both ends. The lower cut is the same as the pitch. Figure 8 shows how the upper cut is figured for rafter number 1. Here we make use of the fact that for a right triangle the two opposite angles are always equal to 90 degrees. Thus, if the one angle is 45 degrees, then the other is also 45 degrees, as the two together are equal to 90 degrees. Again if one angle is 24 degrees then the other is equal to 90 less 24 = 66 degrees.

To find the length we first look for the length per foot run in the table. This multiplied by the run in feet gives the total length. The illustration gives the calculations in detail.

### Explanation of Table

The table given herewith is for framing by degrees. We hope that sooner or later all plans will give the pitch of the roof by degrees. This will simplify the calculations considerably for the carpenter.

### ROOF FRAMING TABLE—COMMON RAFTERS

| Pitch by Degrees | Rise per Foot | Length per Foot—<br>in Inches | Foot—<br>in Feet | Lower and Upper Cuts—<br>Cuts by Square | Cuts by Degrees |
|------------------|---------------|-------------------------------|------------------|---|-----------------|
| 85               | 137.16        | 137.68                        | 11.47            | 1-11½                                   | 85-5            |
| 80               | 68"           | 69.1                          | 5.758            | 3-17                                    | 80-10           |
| 75               | 44.78         | 46.36                         | 3.86             | 6-22½                                   | 75-15           |
| 70               | 32.97         | 35.09                         | 2.92             | 6-16½                                   | 70-20           |
| 65               | 25.73         | 28.39                         | 2.35             | 6-13                                    | 65-25           |
| 60               | 20.78         | 24.00                         | 2.00             | 12-20¾                                  | 60-30           |
| 55               | 17.14         | 20.92                         | 1.74             | 12-17                                   | 55-35           |
| 50               | 14.30         | 18.67                         | 1.56             | 12-14¾                                  | 50-40           |
| 45               | 12.00         | 16.97                         | 1.41             | 12-12                                   | 45-45           |
| 40               | 10.07         | 15.66                         | 1.305            | 12-10                                   | 40-50           |
| 35               | 8.40          | 14.64                         | 1.22             | 12-8½                                   | 35-55           |
| 30               | 6.92          | 13.86                         | 1.155            | 12-7                                    | 30-60           |
| 25               | 5.60          | 13.24                         | 1.1              | 12-5½                                   | 25-65           |
| 20               | 4.37          | 12.77                         | 1.061            | 12-4½                                   | 20-70           |
| 15               | 3.22          | 12.42                         | 1.035            | 12-3¾                                   | 15-75           |
| 10               | 2.12          | 12.19                         | 1.015            | 12-2                                    | 10-80           |
| 5                | 1.05          | 12.05                         | 1.004            | 12-1                                    | 5-95            |

The first column is the key to the table. It has the pitch in degrees.

The second column gives the height of rafter for each foot run or as is stated the rise per foot run. This is not needed for finding the length of a rafter but is convenient for finding the total rise or height of a roof. For example. A roof over a building 30 feet wide is given as 25 degree pitch. The table gives the rise per foot as 5.6". The total rise would be the rise per foot times the total run. Thus 5.6 × 15 = 84.0" or 7' 0".

The third and fourth columns give the length per foot. One gives it in inches and one in feet. We may use either one. An example of each will be given. A roof is 26 feet wide and the pitch is 55 degrees, find the length of the rafter.

Length per foot in inches is 20.92 inches.  
Length is 20.92 × 13 = 271.96 inches or say 22 feet 7 15/16 inches.

Length per foot in feet is 1.74.  
Length is 1.74 × 13 = 22.62 feet.  
22.62 feet is 22 feet + .62 × 12 = 7.44 inches, say 22 feet 7½ inches.

Note that there is a slight difference due to the fact that the table giving the length per foot run, in feet, is figured out only to two decimal places. The first answer is the more accurate.

The fifth column gives the cuts by square in case no protractor is available. The last column gives the cuts by degrees. The first number is the bottom or seat cut and the second is the top or plumb cut.

### Problems

The problems this time will be stated in a little different form. We will tabulate different roofs leaving out certain information. The problems will be to solve for the spaces left blank.

| Roof No. | Pitch | Total run of rafter | Total rise of rafter | Length per foot run | Length of rafter | Cut by degrees |
|----------|-------|---------------------|----------------------|---------------------|------------------|----------------|
| 1        | 35    | 16                  | ?                    | ?                   | ?                | ?              |
| 2        | ?     | 14 ft.              | 14 ft.               | ?                   | ?                | ?              |
| 3        | 40    | ?                   | 80.56 in.            | ?                   | ?                | ?              |
| 4        | 65    | 10 ft. 6 in.        | ?                    | ?                   | ?                | ?              |
| 5        | 20    | 18 ft. 0 in.        | ?                    | ?                   | ?                | ?              |

### Solutions

Roof No. 1:

Pitch is given as 35 degrees, run is 16 ft.  
Rise per foot run for 35 degree pitch is 8.4".  
Total rise is 8.4" × 16 = 134.4".  
Length per foot run is 14.64".  
Length is 14.64" × 16 = 234.24" or 19' 6¼".  
Bottom cut is 35 degrees. Plumb cut is 55 degrees

Roof No. 2:

Pitch not given.  
Total run and total rise are the same, therefore a 12" rise per foot which is a 45 degree pitch.  
Length per foot for 45 degree pitch is 16.97".  
Length is 16.97 × 14 = 237.58" or 19' 9 9/16".  
Bottom and plumb cut both 45 degrees.

(Continued to page 124)





# Questions and Answers

This Department Conducted by  
V. L. SHERMAN

*Have You a Question You Would Like to Have Someone Answer?*

*Have You An Answer to Any of the Questions Listed Below?*

## QUESTIONS TO BE ANSWERED IN THE FEBRUARY ISSUE

*Give Us Your Answer—Those Published Will Be Paid For.*

1. How can sound-proof walls or partitions be built?

2. Where should grease-traps be used, and why?

3. I am told that I can increase the heating capacity of my present furnace by increasing the cold-air faces from one to three. If this is so can you explain why, and how should I locate them?

4. How can an oak floor finished by waxing be made proof against water stains?

5. What success would I have with a common brick house painted white? Or any other color?

6. Will you explain the action and use of a water-softener?

7. Will a kitchen ventilating fan cause an increase in fuel cost, or will it lessen it? I have been told both ways and would like some reasons.

8. To what types or styles of houses is wood siding adaptable?

(Editor's Note: The seventh question is one which is constantly recurring. This department will welcome evidence from anyone sufficiently supplied with facts to warrant a statement. We believe it could be made into interesting propaganda for the promotion of health.)

SEE JANUARY FOR ANSWERS TO NOVEMBER QUESTIONS

## Following are the questions asked in the October issue, and their answers

**Question:** A cement-laid rubble stone wall is to be finished inside with plastered walls. What construction would provide best against cold and dampness?

**ANSWER:** Use mortar, 1 part portland cement to 3 parts clean, sharp sand (no lime), and incorporate in same either a standard waterproofing powder or waterproofing paste. This will require either 8 lbs. of powder or 5½ lbs. of paste per 100 cubic ft. of stone wall.

Rake out mortar joints inside to a depth of about ½ inch and open pores of wall surface with a treatment with standard bonding compound. Make the plaster coat finish of portland cement and sand, 1 to 3, without any lime in it, in two coats, scratch and finish, each ⅜ inch thick, and use a waterproofing powder or waterproofing paste integrally in this plaster in both coats. It will require about 2 lbs. of bonding compound and either 5 lbs. of powder or 3.5 lbs. of paste per 100 sq. ft. of surface for the two coats.

J. TRAVERS,

Waterproofing Service Dept.,  
Genfire Steel Company, Youngstown, Ohio.

**ANSWER:** A cement-laid rubble stone wall plastered inside can be provided against cold and dampness in the following manner: Secure ¾ inch by 1½ inch strips, 16 in. O. C. by means of expansion screws, making the heads flush with the strips. Nail 1-ply roofing on strips, running layers vertically. Lap and cement the same as for roofing. Directly over these strips nail another set of strips, and on these nail fibre board which will serve the double purpose of insulation and plaster base. When applying the board leave a clear space all round and start nailing in the center. This will eliminate buckling. Two air spaces are provided with construction.

JOSEPH C. BOYER, Park Falls, Wisconsin.

**Question:** Can you give me any information regarding a "manual for carpenters" to be published by the Department of Commerce?

**ANSWER:** This publication will shortly be ready for the printer. It is a co-operative undertaking between the National Committee on Wood Utilization of the Department of Commerce and the Federal Board for Vocational Education. It gives, in the carpenter's own language, an account of the various American woods used in building and construction, their relative properties and uses, and their availability. In this publication a detailed discussion is given of the various type jobs done by a carpenter, based on the practices in various parts of the country. It shows how lumber and other wood products may be put to their most efficient use. Economical use of wood products is stressed throughout the publication. In short, this book is intended to give the carpenters practical directions in regard to wood construction not heretofore available in convenient form. There are 20,000 carpenters coming into the field every year, and this publication will afford these apprentices an opportunity of securing the best information available on the subject. The book will be used in vocational educational classes for training carpenter apprentices and journeymen.

AXEL H. OXHOLM, Director,  
National Committee on Wood Utilization,  
Washington, D. C.

**Question:** How is the vanishing point determined in making a perspective drawing of a house?

**ANSWER:** Referring to Fig. 1. Place the plan of the house at any angle with the horizontal picture-plane line and with the corner of the plan on the line. Lay off the distance to

Just try to tear it !

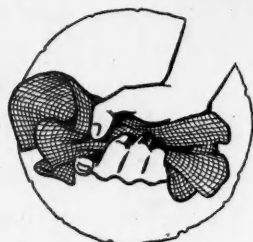
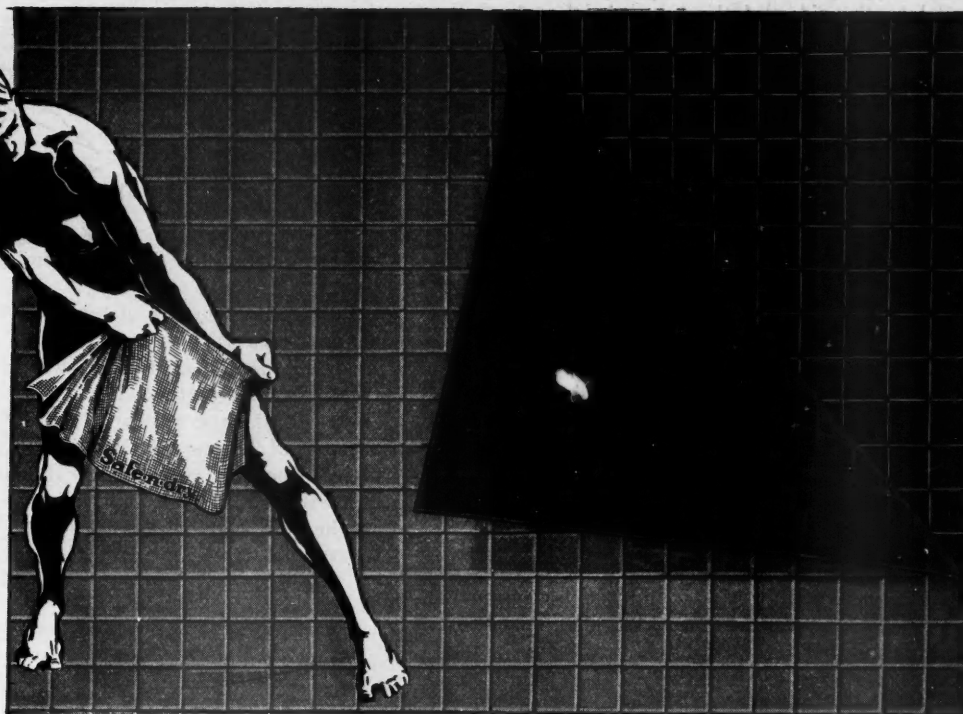

Abuse it—Crumple it—Jump on it—Kick it around

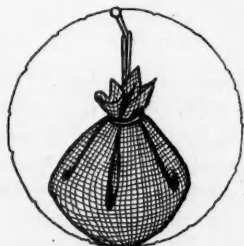

Make it into a bag and fill with water

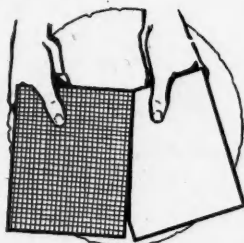

Compare it in any and every way with all others

One—  
Hard-to-heat House Can Destroy Many Future Sales

Safe-n-dry

Super-Building Paper

Everlastingly Insures Against This Possibility

Safe-n-dry permanently insulates a building with Two layers of strong Kraft Paper—Two layers of heavy waterproofing asphalt and One layer of thick finely-woven Jute Fabric.

The cost of labor and materials alone, to apply five such protective coats, one at a time, would be prohibitive, yet Safe-n-dry gives this super-protection in a single sheet—at minimum cost. One man lays it easily without cleats or battens—no matter how hard the wind blows—because Safe-n-dry will not tear in the wind.

For these reasons the foremost Architects have adopted Safe-n-dry as Standard for all structures where building paper may be used—and Wise Builders throughout the country, are insisting that Dealers stock Safe-n-dry for their use. Just try Safe-n-dry once and be convinced.

Generous Sample Test Sheets and other information will be sent gladly to Architects, Engineers, Contractors, Builders, Carpenters and Dealers. Just Mail the Coupon.

Safepack Mills Inc.  
Millis Massachusetts

Safepack Mills, Inc.,  
Millis, Mass.

Gentlemen:

SEND ME THE  
TEST SHEETS

AB-D

Name.....  
Street.....City.....  
Dealer's Name.....  
Address.....

the station point to scale. Draw lines from the station point, parallel to the sides of the house in the plan, up to the picture-plane. Place a horizontal line across the paper at any convenient distance below the picture-plane

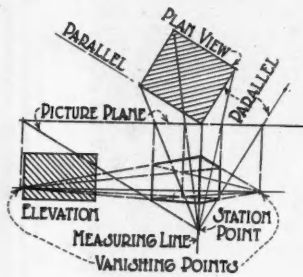

Fig. 1

and drop lines from the points at which the lines from the station point crossed the picture-plane. The points at which the last vertical lines cross the lower horizontal line will be the real vanishing points on the "horizon."

AUBREY P. BENNETT,  
Route No. 1, Box 40-A,  
Ferndale, Washington.

**Question: What experience have you had with non-splitting nails?**

ANSWER: I have often noticed that old-time carpenters cut off the pointed end of nails when they are anxious to avoid splitting of wood. During the last few months I have personally tried out a nail of the non-splitting variety. I have used the nails for general work around the house, such as nailing of window casings, repair work of all kinds, and the nailing of thin box lumber. While I would not say that these nails are absolutely non-splitting, they certainly reduce the tendency of the wood to split when nailed. I extended this test to a Government department where a considerable amount of box and crate construction is undertaken. The foreman in the plant informed me that he was very well satisfied with these nails, and that their use had saved a considerable quantity of lumber.

The National Committee on Wood Utilization is keenly interested in the development of non-splitting nails because we recognize that the reduction of splitting in wood is a matter of great economic importance.

ANSEL H. OXHOLM, Director,  
National Committee on Wood Utilization.

ANSWER: Our first job of laying floor with the non-splitting type of nail involved 40,000 sq. ft. of maple, 2 1/4 inch, No. 3, (factory maple), covering about 90 rooms. Out of the original order for 55,000 ft. we had about 4,000 ft. left, which, of course we would anticipate and save on the next such job. While the non-splitting nails cost more than the ordinary type we figure that through the lessening of split tongues and consequent lessening of discarded nails we cut that item at least 5%. On labor we saved perhaps 10%. We found that the nails could be handled as readily as the ordinary. The results of flooring with No. 3, which allows 30% of 12-inch stock, was really surprising. While we knew that the milling was good we certainly did not suppose such a fine job could be made of such stock. Discounting split wood of any kind, it is well to remember that it costs more to get a nail out than it does to get it in.

GEORGE MILLER, President,  
C. A. Moses Construction Co., Chicago, Ill.

The editor of this department framed an attic room some time ago, using fir. He can say that fir is all right so long as the worker does not splinter it. The non-splitting nail seemed a soul-saver in this particular case since lack of practice and impatience would soon have had the wood and the worker at logger-heads.

**Question: If the scissors truss shown in the sketch, Figure 2, carries a plastered ceiling, is the construction shown strong enough? Can you find the strains in the different members for me? The trusses are to be two feet apart and the covering is sheathing and composition shingles.**

ANSWER: Stresses in the scissors truss can readily be figured graphically but it is unnecessary for the conditions given as

the dead load including the weight of the truss is only 8 or 9 lbs. per lineal foot of the upper chord. Keep the pitch as steep as shown so that snow will not lie on the roof, and the truss will be amply strong to resist the ordinary wind stresses which act on one side only.

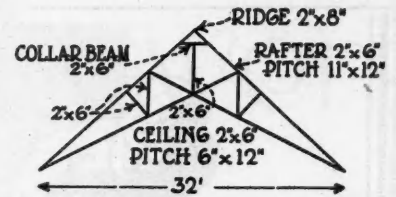

FIG. 2—ROOF TRUSS TO CARRY CEILING

The lower chord is in tension which will not increase the bending stress from the weight of the plastered ceiling, and 13 or 14 foot span of this lower chord is not so long as to crack the plaster by deflection. The horizontal reaction or "kick-out" at the supports should be taken care of, in the absence of horizontal ties, by notching the rafters over the plate. Too much dependence should not be placed on spiking at these points. But it is important to spike all joints well as the joints are the weak spots in the truss. Take care to avoid hanging any heavy load from the truss.

L. A. BRUBAKER,  
29 Virginia Road,  
Maplewood, N. J.

**Question: Will you give me a design for a high corner fireplace such as is used in Sweden?**

ANSWER: The sketch, Figure 3, shows a Swedish corner fireplace but instead of the ordinarily used straight flue a smoke-shelf is put in. If desired, a damper may also be used. A somewhat simpler construction is obtained if the chimney is placed with its sides across the corner of the house instead of parallel with the walls.

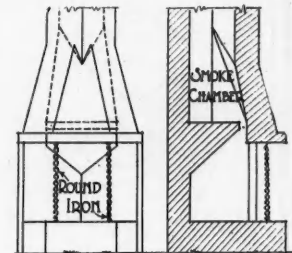

FIG. 3

PAUL NESS,  
842 East 30th St.,  
Portland, Oregon.

**Question: I have a doorway opening 2 feet 8 inches wide by 6 feet 8 inches high into which I wish to put some sort of folding door as there is only 1 foot 8 inches of space in which to swing back. Can anyone show me how it can be done?**

ANSWER: Figure 4 is a sketch submitted by Harold Oakley, Rhinebeck, N. Y. In his sketch Mr. Oakley advises spring hinges on the jamb with butts on the break. The editor has taken the liberty to suggest another scheme which worked out very well several years ago. A track of purple heart was built over the head of the door in which ran a steel pin that was screwed to the top of the door. Then a spring was placed over the top of the door so that on moving the door it would come under tension, but when the door was closed or opened back it was under less tension. A push plate was used instead of a latch. The door could never stand partly open unless blocked. It was either open or closed.

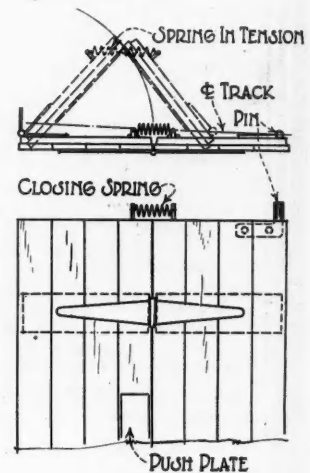

FIG. 4



# Andersen FRAMES are Beautiful Enduring Weather-Proof

Who wants to install window frames that will rot and have to be replaced in ten years or less? No good builder does, of course, and that's why so many of them are buying frames with *genuine* White Pine sills and casings.

Houses built of *genuine* White Pine have withstood the wearing effects of 300 years of weather. This wood will not rot, warp, swell or split, and it takes paint smoothly.

Other features of Andersen Frames which both builders and home-owners approve are listed below under the heading, "Why Contractors use Andersen Frames."

Your nearest Andersen dealer will gladly tell you more about Andersen Frames and how they will help you to gain a reputation for good construction. Or we shall be glad to send you descriptive folders if you will write us.



Home of Mr. Eli F. Seebert, South Bend, Ind.  
Andersen Brick Veneer Frames installed.

**The Andersen Brick Veneer Frame**  
This cross section shows the detail construction of the standard brick veneer frame No. 151, but it cannot show the beauty of Clear White Pine and perfectly smooth millwork which is characteristic of all Andersen Frames.

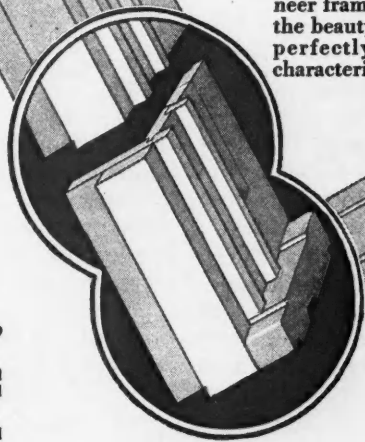

**SUPERIORITY**  
GUARANTEED  
by this trade mark

THE  
**Genuine  
White Pine  
Sills and Casings**

1 White Pine for PERMANENCE

3 Weather-tight for HOME COMFORT

4 Standardized Quantity Production for ECONOMY

2 Styles and Sizes for BEAUTY

4 Available at dealers for CONVENIENCE

## Why Contractors use Andersen FRAMES

- (1) Patented, noiseless, long wearing Andersen pulleys used exclusively.
- (2) Genuine soft White Pine sills and casings—last a life-time.
- (3) Patented, exclusive weather-tight features including groove for wide blind stop.
- (4) Absolute accuracy of milling.
- (5) A Frame up in 10 minutes.
- (6) Standardized styles and sizes, convertible for all architectural needs.
- (7) Nationally known and distributed.
- (8) Dependable because guaranteed by a reliable manufacturer.

WHEN WRITING ADVERTISERS PLEASE MENTION THE AMERICAN BUILDER

## Hoover Enlists Builders

(Continued from page 61)

trial and business leaders who announced the unanimous opinion that "there was no reason why business should not be carried on as usual" and that construction work should be expanded in every prudent direction, both public and private, so as to cover any slack of unemployment. Later in the day another conference was held with labor leaders and on November 22 one with representatives of the various construction industries.

After the conferences with labor and industrial leaders the President also announced that he had been authorized by the employers present to say that they will not initiate any movement for wage reduction and it was their strong recommendation that this attitude should be pursued by the country as a whole, so that consuming power may be maintained, and by the representatives of labor that no movements beyond those already in negotiation should be initiated for increase of wages.

Frank H. Smith, president of the Portland Cement Association, said after the conference that President Hoover seems to have pretty definite ideas as to what he wants to accomplish, and that is to stimulate construction generally, both as to apartments, office buildings and homes, industrial and public construction, and similar activities that have been retarded by high money rates.



## Waste Makes Building Costly

(Continued from page 71)

Just as a building under construction looks convincing and fine, so the tremendous detail and accumulated knowledge embodied in a set of plans and specifications is apt to impress an owner as the final solution of a building problem.

On the contrary, a set of plans and specifications must in many particulars be the solution of imagined conditions. No one, however experienced, can at a given time foresee all the conditions which must be coped with weeks or months later.

An owner may change his mind or desire additions or deductions. New conditions arising during the course of the work may recommend changes. The designer, seeing his plans taking actual form, may discover better ways of solving his problems. If such changes result in additions to the original plans and specifications their costs are known in the building trade as "extras."

## Inflexibility of Contract

I cannot say how many hundred times in the past twenty-five years I have heard engineers and architects say that they built this or that large building "without paying a single dollar for extras." One may make his own estimate of what rigidity has cost the various owners in lost satisfactions and values.

On the other hand, desirable changes may very well be in the direction of simplification or deductions from original plans. A designer who lays out the foundations of a building, for instance, may have at most a few borings and test pits from which he can test the bearing quality of the soil. If these explorations indicate some of the soil to be of doubtful character, considerations of safety may compel him to design expensive foundations capable throughout of carrying the specified loads under the worst conditions indicated by the borings, only to have the actual excavations reveal no such need for expense.

Even where reforming the plans and specifications would make for such heavy savings as in this case, however, it must be admitted that it oftentimes is more satisfactory to carry the job through without change than it would be to enter into the interminable difficulties so commonly met in trying to make reasonable adjustments with the general contractor or sub-contractors involved. Yet passing over such matters does not conceal the fact that there are millions and millions of dollars of waste involved in thus building to the imagined conditions rather than to the actual conditions of a job.

## Ideas Are Penalized

The difficulty lies, if you will, in the antiquated business relationships so frequently used. An owner can hardly expect to get superior results when the natural tendency of a contract is to penalize the development of new ideas by his designer and make of the builder an opponent under pressure to profit through light allowances for deductions and heavy charges for extras. If the owner, in the beginning, chooses for his job a contractual arrangement which does not encourage the co-operation of designer and builder in his, owner's behalf, he can hardly expect to obtain the extra economies, values and satisfactions which full and natural co-operation alone can secure.

Now a building operation is performed by a procession of trades, one following the other and each dependent for its progress on the progress made by the trades preceding and accompanying it. The procession starts with the steam shovel or the pile driver, followed by the foundation builders, then come the steel men and masons and so on until the dirty men who have done the rough work are chased off the job by white-coated painters who finish with nicety the inside of the structure. One trade cannot proceed without another. Their materials must arrive in a streamline. The whole performance interlocks. The progress schedule for a modern construction job is a complicated time-table fixing the arrival and departure of these different trades.

## Incompetent Sub-Contractors

Incompetent sub-contractors are generally known as such and yet it is hard to avoid them under the conventional procedure of contracting for new construction. A general contractor takes proposals from some twenty-five or thirty sub-contractors in making up his figures.

The only hope that an inferior sub-contractor has of getting jobs is to offer low prices. A sub-contractor for plumbing, say, tenders a price substantially below the price tendered by a competent sub-contractor. The general contractor who fails to use this price will be a high bidder. In the procession, under this pressure, then comes a delegation of raw recruits; the procession is delayed and costs mount.

Now it happens that sixty-five to eighty-five per cent of the average modern job consists of materials or sub-contracts bought by the general contractor. It follows that an exceedingly low bid from a general contractor usually means that he is going to buy his material and sub-contracts cheaply. To the extent the general contractor goes on a slumming party for low sub-bids, sheer value is being traded out of a job for a price. It has been said, and I believe with truth, that five per cent out of the proper



**ONLY ONE MOVING PART...**

**N**OW the Reid-Way Whirlwind Sander comes equipped with an amazingly new motor which practically doubles the power. This motor was developed especially for Reid-Way by the General Electric Company. The powerful new revolving-field motor makes the Reid-Way the giant of the sanding machine field. Due to the Reid-Way exclusive design in which the motor itself is the sanding drum, every ounce of this tremendous power is available for productive work. No complicated driving mechanism to cause friction losses and excessive wear. Learn more about the amazing Reid-Way Whirlwind which has given the entire country a new conception of a light sanding machine. Exclusive Reid-Way dust control—greatly increased power—no increase in price.

**THE REID-WAY COMPANY**  
748 No. 16th STREET  
CEDAR RAPIDS, IOWA

The Reid-Way Company,  
748 North 16th Street,  
Cedar Rapids, Iowa.

Gentlemen: Please send free circular describing the new Reid-Way Whirlwind Sander, equipped with special G. E. motor.

Name \_\_\_\_\_  
Address \_\_\_\_\_

WHEN WRITING ADVERTISERS PLEASE MENTION THE AMERICAN BUILDER



price of a building results in twenty per cent loss of value. The statement cannot be proved. It must remain a matter of opinion, for any new building—like any new automobile—is satisfactory at first. It takes time and its attending maintenance cost to demonstrate the real worth of a building.

It may be argued, or assumed, that none but a reputable contractor will be considered and that no general contractor of repute will trade out value for price. The compelling answer is that, under a system of award which starts with fixed plans developed largely from imagined conditions, and stipulates that, other things being equal, the low bid wins, it is only a matter of degree in which the owner will pay in lost values.

To combat this natural result of an unsound procedure, another wasteful procedure is commonly invoked. The architect or engineer places on the job an inspector whose duty it is to see that there is delivered the quality of materials and workmanship called for in the specifications.

Theoretically, a real representative of the designer, permitted to co-operate fully with the general contractor and the sub-contractors, would see that advantage is taken of new and unforeseen conditions; that ideas for simplification and improvement of the work are submitted promptly to the architect and, through him, to the owner; that there shall be minimum delay in making decisions and in carrying them into effect—all to the end of an efficient, economical job. Most men, progressive and successful in business, will acknowledge that in their own field such co-operative, co-ordinated effort is a pre-requisite today to success.

In their building problems, however, it is a strange fact that these same men still cling to a system that from the start sets up an opposition of interest to their own, discourages if it does not preclude co-operation and puts themselves on the defensive, protected only by specifications based on imagined conditions and by an inspector stripped of all power except that of rejection. It would be quite as logical, it seems to me, to buy surgical operations on this same basis of price and inspection. Cheap price does not necessarily mean high value and inspection is no substitute for honesty and ability. Yet heaven only knows how much money is annually spent in the United States, and wasted under this system.

### ❖ "Modernesque"

(Continued from page 62)

"When we approached the roof it was difficult both as to the form and as to material. However, we secured an asbestos shingle that, although not strictly modern, at least is one of the latest roof-covering products, and the effect is most pleasing.

"Our iron balconies in every case are original designs interpretative of the finest modern iron work. The brackets supporting the balconies seem a small item, but required a great deal of research.

"The shutters throughout the house will remind you of the Frankel school of modern architecture and of the New York skyscraper. We have adapted the receding lines, of course, with a feeling for proper proportion. Our shutter dogs express a very common form much used by the modernists.

"All flower boxes, both stationary and movable, have been developed with some one of the modernistic forms in mind.

"The whole interior, both as to proportion and

line, has followed as far as possible the precedent set by continental Europe. Nothing was done without thorough study. We searched the American market for the best modernistic form of hardware and regret to say that we had a difficult time securing suitable designs.

"In our fixtures we were more successful although at least 50 per cent of the designs utilized were imported. And the same may be said of our papers, all of which were imported from Germany, England and France, with the exception of one room.

"In our flooring we experimented. The most effective room was one in which we utilized a quartered sawed Philippine mahogany flooring. In another we used oak flooring, which is an American product with the sap stains showing in every strip. This is processed oak block and seems to lend itself to our modern finish. Throughout the house we used other forms of oak flooring. One is developed of ordinary oak parquetry strips with random inserts of a mahogany band. Another room is in maple, another in gum, and another in birch. These were so utilized that they form a suitable field for the other decorations in the rooms in which they were used.

"All trim is of simple design in sharp block outline; likewise the washboard and moulding wherever used are typically modern.

"Needless to say, the plastering was probably the most important craft in building this home. The modernists depend upon plain surfaces of little ornamentation, but beautiful proportion and balance in the mass. Here was a job in this house for real craftsmanship. It is almost impossible to describe in a brief article the forms used, although the photographs will suggest mostly sharp angles. The stepped surfaces would seem to be the keynote. We have introduced in all ceilings a blending of at least two to four colors. All of our interior trim has been treated this way. This was done by a man most skilled in this field, as the success or failure of the interior of this house depended largely on the skillful blending of contrasting and complimentary colors.

"One or two structural problems, which seemed impossible of accomplishment at first, were solved by the free use of structural steel.

"The sheer beauty of 'Modernesque' as to the interior, is based, as all beauty is based, on proportion and balance, and the free use of unusual delicate coloring.

"The French modernists use iron freely. We followed their lead as far as possible. One example is the iron rail between the living room and the dining room. This we finished in a hammered and buffed natural iron. The effect was accomplished by hammering the iron while in a soft state, not while cold, and by bringing it to high state of polish, after which it was coated with one coat of pure linseed oil.

"Before painting, it was necessary to coat the plaster surface with one coat of zinc sulphate and one coat of varnish size. All tints used were flat. No gloss paint of any kind was used.

"All doors are 1¾ solid slab doors with a raised veneered modernistic design, hand pointed in suitable colors. This seemed most suitable.

"In the main bathroom we used one of the oldest building materials developed in such a way that it is the most striking room in the house. We used marble, selecting colors and designs for the floor and side walls in a novel manner."

### A New with I

There is r  
Disston No  
by Disston

A plunger  
place, doin  
Pressure o

Blade may  
down. Ha  
does not i  
is reversed

You can g  
or a 14" h  
14" nail-c



### An Im

The Dissto  
with a hea  
keep it st  
the cut. T  
smoother  
are balance  
new No. 4  
12, 14 an  
at your de



### Band

Disston B  
ment in l  
plants th  
makes bar  
all widths  
18 inches  
can get fo  
Disston B

# DISSTON *Lightweights*... the saws for today's sawing

**H**AVE your hardware merchant show you the new Disston *Lightweight* (Ship pattern) saws. For the lighter work you are doing today, you will find them more convenient.

In the Disston line you can find the exact saw to meet your preference: Eight Regular pattern (standard width) saws and seven *Lightweights* to choose from. Straight backs and skew backs. Handles with larger hand holes and the new Disston weatherproofed finish.

The new Disston Hand Saws will run with less set, cut faster, cut easier, and stay sharp longer than any other hand saws ever made. They are true-taper ground, and have better clearance, better balance, better steel and better temper than any other saws ever made.

HENRY DISSTON & SONS, INC.  
Philadelphia, U. S. A.  
Canadian Factory: Toronto



### A New Compass Saw with Reversible Blade

There is no compass saw like the new Disston No. 115, invented and patented by Disston.

A plunger in the handles locks blade in place, doing away with screws, levers, etc. Pressure on plunger releases blade.

Blade may be inserted with teeth up or down. Handle has square top, which does not interfere with work when blade is reversed for undercutting, etc.

You can get this saw with either a 12" or a 14" blade, both 8 pt. Out No. 1150 14" nail-cutting blade fits same handle.

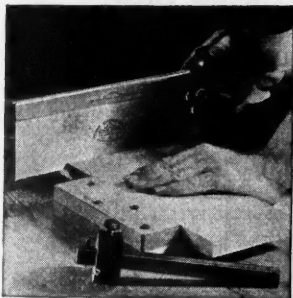

### An Improved Back Saw

The Disston No. 4 Back Saw now is made with a heavier back, to stiffen the blade, keep it straight, and hold the teeth in the cut. Teeth are shaped and set to cut smoother and easier. Blade and handle are balanced to insure better work. The new No. 4 Back Saw is made with 8, 10, 12, 14 and 16-inch blades. Ask for it at your dealer's.



### Band Saws for Better Work

Disston Band Saws are standard equipment in lumber mills and woodworking plants throughout the world. Disston makes band saws for every machine, in all widths from one-eighth of an inch to 18 inches. Your dealer has in stock, or can get for you, any width and length of Disston Band Saw.



**"THE SAW MOST CARPENTERS USE"**

## If you own or operate circular saws

You will find much information of value to you in the new bulletin, "Disston Small Circular Saws and How to Use Them." It tells how to refit circular saws and how to operate them most efficiently. It also describes the various types of small circular saws made by Disston from Disston steel—saws of the same quality as used in the great lumber mills. The coupon will bring this bulletin.

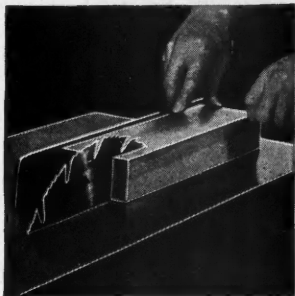

Henry Disston & Sons, Inc., Philadelphia, U. S. A.  
(In Canada, address Henry Disston & Sons, Ltd., Toronto)  
Please send Bulletin on Circular Saws and other helpful data.  
Name and Address.....

WHEN WRITING ADVERTISERS PLEASE MENTION THE AMERICAN BUILDER



# How Dan Does It

*A Department for Passing "Life Savers" along to other Builders*

*\$2 for an Idea*

Dan is an ingenious cuss. Nothing ever stumps him. He always knows the way out when he runs into a tough problem out on the job or in the office. Dan is editor of this Department and will pay \$2.00 each for every good idea he can use here to show and tell other builders "how to do it." Send him a rough sketch and a short description of what the tough job was and how you handled it.

Address Dan-Do-It, care of American Builder, 105 W. Adams St., Chicago, Ill.

## A Handy Door Clamp

THE sketch shows a device which I use for holding a door steady while mortising for the lock. I used a piece of material  $\frac{3}{4}$  inch thick,  $2\frac{1}{2}$  inches wide at the top and tapered to one inch at the bottom, and 37 inches long. Four inches from the top I made fast a two by two butt hinge, then cut through the wood to the hinge joint. I made two pieces like this.

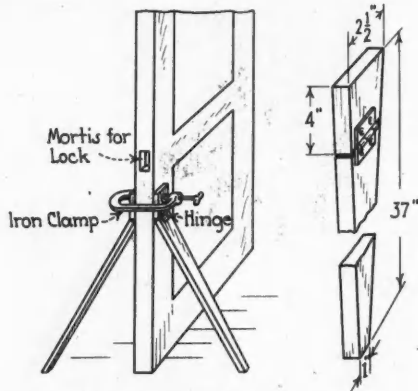

The Clamp Shown in Use and an Enlarged View Showing Its Construction.

To use this device, I place one piece on each side of the door with the bottom ends on the floor, just far enough apart to brace well, and with a small iron clamp I clamp the tops against the door. This holds the door rigid where the work is to be done. It is quickly made fast, does not mar the door and the door can be swung by releasing the bottoms of the braces on the floor.

W. W. DORMAN, 1424 25th St., Santa Monica, Cal.

## Another Way to Cut Bridging

I HAVE seen many and various ways of cutting bridging illustrated, but have never seen the method commonly used among carpenters in this vicinity explained. Since it seems to me to be as fast, accurate and simple as any method I ever saw, I will pass it along to others who may not know of it.

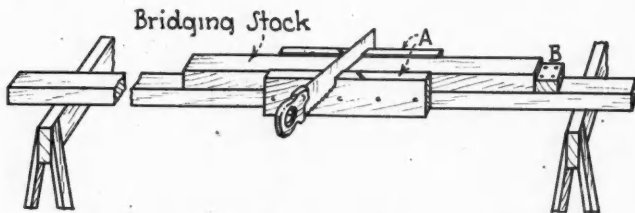

This Is Practically a Simple Miter Box Specially Adapted to Cutting Bridging.

Take a straight piece of two by four, 10 or 12 feet long. A fairly long piece is used as it supports a long piece of

bridging stock better. Nail a piece of one by eight, about two feet long, marked A in the sketch, on each side of the two by four, exactly as though making a common wooden miter box, which is really all that this is. Place the two by four on a couple of horses, determine the bevel cut of the bridging, lay this off on the box and saw through.

Cut a piece of bridging of the length required, place one end against the saw in the cut and nail the block B to the two by four against the other end. Place the bridging material in the box, slide it against the block B, and cut by placing the saw in the miter box. Your bridging will always be the same length and have the same bevel.

ERNEST GUSTAFSON, 31 Spruce Ave., Kane, Pa.

## Another Better Stair Idea

I THINK I can improve much on L. W. Pike's idea for better stair work as illustrated in the October issue. When a carpenter cuts out the joists for a stairway it nearly always happens that only short stub joists remain on either

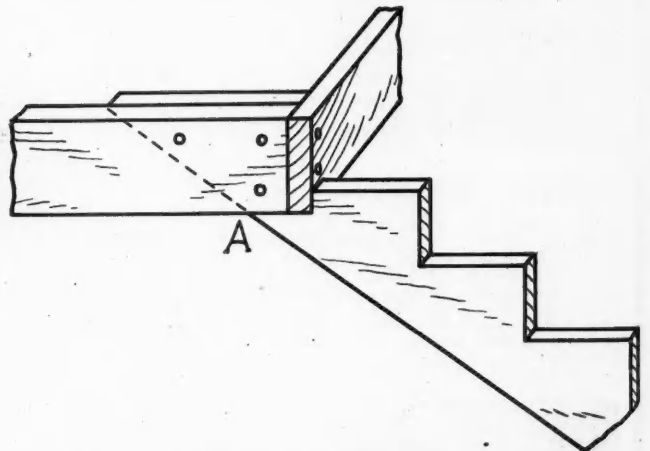

Stairs Built Like This Are Strong and Firm and It Is a Simple Method.

end and only a single header is needed. I cut the top riser back the thickness of the header and let it come up behind the header as shown in the sketch. I then spike to the joist and also into the riser through the header.

FOSS TAYLOR, 1730 Newton St., Columbus, Ind.

"The Law of Building Contracts and Mechanic's Liens", by Myron H. Lewis, C.E., L.L.B., discusses in simple, non-technical language what every owner, contractor, subcontractor, engineer, architect, mason, plumber, carpenter and building material dealer should know about the law of building contracts and mechanics liens, to be used as the tools of his business. It is published by the author at 507 Fifth Ave., New York City. Price, \$2.00, plus 10 cents postage.





# NOW - THIS LOW PRICE WILL BUY YOU A BIGGER AND BETTER SPRAY OUTFIT

## Complete Spray Outfits *Meeting Every Requirement...*

Every painting and finishing operation is served by specialized DeVilbiss spray outfits which are designed and built to do the particular work for which they are intended with the maximum economy of labor and materials. Whatever may be your painting or finishing operation, look to DeVilbiss for:

*Spray guns of various types and sizes.*

*Pressure feed paint tanks and containers.*

*Spray booths, exhaust fans, and approved lighting fixtures.*

*Air compressing equipment.*

*Air transformers and accessories.*

*Air and fluid hose and connections.*

*Complete outfits from the smallest hand-operated units to the largest industrial installations.*

Write for catalog of the DeVilbiss spray equipment that fits your individual need.

HERE is the biggest value per dollar of cost ever offered in a spray outfit by this company or any other as far as we can learn. Consider—and compare—the specifications of this DeVilbiss Spray-Painting and Spray-Finishing Outfit Type NK-606.

It is fully complete, including the famous DeVilbiss Spray Gun Type CH; one-half horse power electric motor; a real standard type, full capacity ball-bearing DeVilbiss air compressor; 2-gallon pressure paint tank with full size opening; 24 oz. quickly detachable clamp top metal cup for attachment to gun; air and fluid hose and connections sufficient to give a working radius of 20 feet from compressing unit and 12 feet from paint tank. It is compact, motor and air compressor being mounted on a steel base with ball-bearing swivel casters. Weighing but 104 pounds, it is easily transported. It runs with surprising quietness and without vibration.

The DeVilbiss Type CH Spray Gun is a real production spray gun. It is light, perfectly balanced and made to successfully handle a wide range of materials. Comfortable pistol grip and large trigger make it easy to handle without fatigue. It is made with the famous DeVilbiss ball-and-cone spray-head assembly which assures self-alignment of nozzle parts at all times. The spray-head is easily adjusted to produce various widths and patterns.

Every contractor and builder will find almost constant highly profitable use for this remarkable DeVilbiss Type NK-606 Spray Outfit. Everyone can afford it, for the price with single phase, 60 cycle current is only \$164.90 complete.

# DeVilbiss

Spray-PAINTING FINISHING System

THE DEVILBISS COMPANY . 238 PHILLIPS AVENUE . TOLEDO, OHIO

NEW YORK

PHILADELPHIA  
ST. LOUIS

*Sales and Service Branches*

CLEVELAND DETROIT INDIANAPOLIS  
SAN FRANCISCO WINDSOR, ONT.

CHICAGO

*Direct factory representatives in all other territories*

WHEN WRITING ADVERTISERS PLEASE MENTION THE AMERICAN BUILDER

## Favorable Outlook for Building

(Continued from page 60)

that any pronounced effect of stock market liquidation on increasing construction activity will be gradual.

"I do not believe that the recent heavy liquidation in the stock market will have any pronounced effect on building construction immediately; however, such liquidation will undoubtedly in time prove a stimulating force upon the building industry," said Mr. Roberts.

"For the last year and a half, building construction has lessened in volume because of the abnormal competition of the stock market. Hundreds of millions of dollars have been used to carry on the Wall Street activity. The result has been that all branches have suffered from diverted attention to respective fields of commercial and industrial activity and from a somewhat burdened credit situation.

"The building industry has not been an exception and there has been a consequent slowing down in activity as is shown by the decrease in building permits in most of the building centers of the nation. So far this year the decline over the country generally has been approximately seven per cent," continued Mr. Roberts.

### "Slow, Steady Upswing for 1930"

"Fundamental conditions, however, have been considerably improved. Building is a necessity in modern life. There is a gradual increase of population in this country, as well as a rather marked upward trend in the standards of living. The demand for better and more modern structures is apparent so that in addition to the demands for new buildings, to take care of growth in population and housing of expanding industrial enterprises, there is an accumulated demand for buildings to replace old, obsolete buildings which in many cases are not earning enough to pay their taxes and expenses.

"It is evident that there is an underlying demand for new building development, but from a concensus it appears that conservative bankers believe actual improvement in the building situation will be a slow, steady up-swing as the year 1930 progresses."

With funds being diverted from stock investment, the reservoir of investment funds can be drawn upon to finance construction. The psychology of the investment public is gradually swinging to interest in the bond market or to investment in stocks pretty much on a valuation basis of what the stock will earn. While it is possible to discount the future value of a stock to some degree, the safest valuation test is the determination of what the stock will earn.

When the public realizes that an investment in bonds means safety of principal as against an investment in stocks with chances of either loss or suddenly enhanced values, the financial situation will be such that the investment houses can more easily purchase for their own account and distribute issues on major building projects.

A speculative building project will not likely find ready financing any more than a non-dividend paying stock will find easy distribution as prior to the November break in the market.

As building construction swings upward in volume, a favorable reaction will be felt in business generally. Inasmuch as building construction volume has been showing decreases for several months, it is believed that the country could stand a more intensive building program without disturbing the delicate balance of supply and demand.

## The skies have cleared INVEST NOW in a HOME

**STOCK MARKET UPSETS** have no effect upon the sound value of a home. Owning a home is a sensible investment . . . home owners never fear the click of the stock ticker.

There are clear skies ahead! Smooth financial sailing! Let's talk over this new home of yours; discuss plans; arrange the necessary financing.

Building materials were never better, prices were never more reasonable. Real estate is purchaseable in a multitude of convenient ways. Skilled labor is available at fair wages. This indeed is the time to build . . . to put your money where you get your full money's worth. Invest wisely in a home . . . it is one investment which you will never regret, for its returns are rich in happiness and steadily increasing value.

{ YOUR NAME }  
{ AND ADDRESS HERE }

Nov. 15, 1929.

### EDITOR AMERICAN BUILDER:

Building prospects are good, and in our opinion the speed with which residential building picks up depends almost entirely upon the effort put behind it by the people most interested.

As our contribution we have prepared and are having our salesmen show to each lumber dealer they call on five suggested newspaper advertisements. (One is reproduced above.) Where dealers or builders wish to use these, we are furnishing proofs so the local newspaper can set up the advertisement.

These are our contribution toward helping to tell the public the home building story and so divert money in his town into home building channels. We feel that undoubtedly you, too, will want to give this subject editorial support, and you are at liberty to reproduce any or all of these advertisements that you see fit.

H. E. Gosch,  
President, Creo-Dipt Co., Inc.

A

Suc  
so  
mo  
It  
yea  
ful  
it  
wh  
cou  
you

THE A

Send S  
Name  
Address  
City  
State

# An Ideal Christmas Gift

## That Lives Throughout the Year

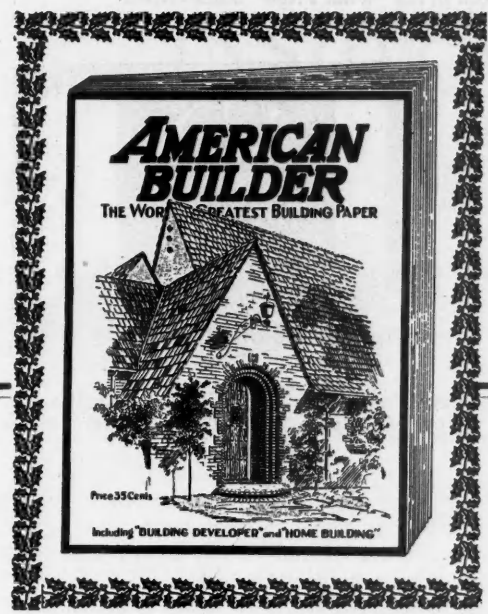

### A Year's Subscription to the AMERICAN BUILDER

With Which Is Consolidated "Building Developer" and "Home Building"

**ONE YEAR**  
(12 Copies)  
**\$2.00**

**TWO YEARS**  
(24 Copies)  
**\$3.00**

FOR those friends of yours, engaged in the building industry—Contractors, Builders, Architects, Real Estate Builders, Sub-Dividers, Building Material Dealers, Building and Loan, Building Finance, Property Management—we suggest a year's subscription to the AMERICAN BUILDER as a timely and exceedingly appropriate Christmas Gift.

### We Will Send An Attractive Christmas Card Announcing the Gift in Your Name

Such a gift will be appreciated because it will be so helpful. The AMERICAN BUILDER is the most widely read magazine in the building industry. It will reach your friends *twelve times during the year*, each copy, with its attractive covers, beautifully printed in four or more colors, bringing with it a pleasant memory and a kindly thought of you who sent it. No other gift, regardless of price, could so exactly fit the needs of these friends of yours.

And best of all—the cost of this gift is so small and it is so convenient for you—we will care for all the detail. An exceedingly attractive announcement card with appropriate holiday greeting, will be sent a few days before Christmas, to each of your friends, announcing the gift in your name. A single subscription costs \$2.00. Two or more gift subscriptions may be sent at \$1.50 each. *These prices are for subscriptions only. You must order direct from the AMERICAN BUILDER.*

**\$3.00 will pay for ONE 1-year Gift Subscription and your own 1-year renewal subscription.**

Foreign Subscriptions \$2.00 per Year Extra

**\$4.50 will pay for TWO 1-year Gift Subscriptions and your own 1-year renewal subscription.**

Use This Form to Send Your Order

THE AMERICAN BUILDER  
Chicago, Ill.

Date.....

Enclosed find \$..... Send AMERICAN BUILDER one year to each of the names enclosed and notify each person that subscription is a Christmas gift from me.

Dec .29

Send Subscription to

Name .....  
Address .....  
City .....  
State .....

Tell Subscriber it is a gift from

Your Name.....  
Address .....  
City .....  
State .....

To send additional Christmas Gift Subscriptions, write names and addresses on separate sheet and attach to this form. Send \$2.00 for one Gift subscription; \$1.50 each for two or more.

WHEN WRITING ADVERTISERS PLEASE MENTION THE AMERICAN BUILDER



# What's New in Equipment for Buildings

For further information in regard to any item described in the "What's New" Departments address American Builder Information Exchange, 105 W. Adams St. Chicago

## Plate Glass Shower Doors

THE modern bath and shower, with spotless tile floor and walls, is really one of the beautiful features of the home. To further beautify the bath, plate glass shower doors have been developed to replace the curtains originally used to prevent splashing from the shower. Such a door can be wiped clean and dry as easily as the tiling, and gives the bathroom that spotless, sanitary appearance which is so much desired.

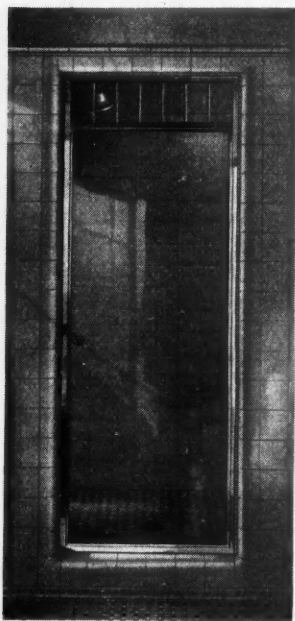

A High Grade Plate Glass Shower Door at a Price That Makes It Available for Any Home.

Up to the present time these doors have been priced so high that the home builder of moderate means could only look upon them as a luxury and pass them up as such. Now, however, a door has been placed on the market at a price to allow the use of this refinement in the most moderate home or apartment.

These doors are a product of careful, accurate workmanship. They fit tightly and permit no leakage. No water can splash beyond the shower cabinet when the door is closed.

They are made with frames of rust-proof metal; finished in lustrous chromium plate, with polished plate glass panels. Special finishes, such as

silver or gold plate, may be had if desired.

An outstanding feature in the construction of these doors is adjustable jambs. The tile at the shower cabinet entrance is practically always uneven, and the plain jambs ordinarily used do not allow the door to fit tight. These new jambs are adjustable to allow for this unevenness of the tile, and assure a perfect fitting installation.

These shower cabinet doors are carried in stock in standard sizes to fit finished openings two feet by six feet and two feet two inches by six feet two inches, and can also be made in special sizes.



## Glass Panel Ventilating Fans

HOME ventilation is becoming more widely appreciated every day and the ventilating fan is rapidly becoming an essential part of the equipment of the modern kitchen. Such ventilating fans may be built into the wall or may be installed in the window opening. The latter type is commonly set into a steel panel. A glass panel model has now been introduced, however, which is particularly desirable as it permits more light from the window.

This new glass panel ventilating fan is similar in construction to the steel panel fan but has a glass panel at each side of the fan. It is especially desirable where there is

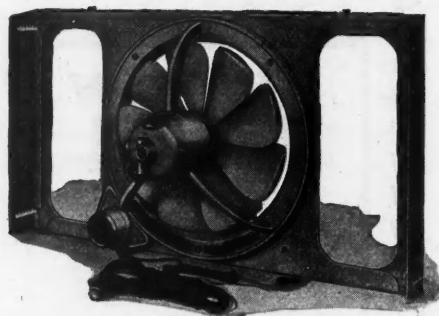

Fan Ventilators for Window Installation Are Now Available with Glass Panels to Admit More Light.

only one window in the kitchen or where the light is poor.

This panel is made in two sizes. The smaller one fits windows from 26 inches to 36 inches wide and the larger one fits windows from 36 inches to 46 inches wide. It is shipped complete with fan and switch but without glass. The glass is cut to fit the installation.

The appearance of this fan is particularly attractive. The motor is finished in aluminum and harmonizes with the pearl gray panel, frame and wheel. The fan itself is a 12-inch 9-blade wheel designed to move a large volume of air. The blades, supporting arms and panel are of pressed steel, light in weight but strong. The fan is quiet in operation. A reversible motor can be supplied, if desired, at the same price.



## Enameled Steel Septic Tanks

FOR homes, camps, golf clubs, resorts, summer cottages and hotels, or any place where sewers are not available, it is possible to have entirely sanitary, modern, inside toilets by means of the septic tank system of disposal. The septic tank shown here has been designed and manufactured closely following the recommendations of the United States Public Health Service, whose many years of experimental work make it an authority on rural sewage disposal.

These tanks are water-tight and unbreakable, being made of an alloy of copper and plate steel, welded throughout and coated with heavy corrosion resisting enamel. Four sizes ranging from 152 gallons to 338 gallons capacity are available. In case larger units are required two or more tanks can be coupled together in series, in which case all but the last tank are used without partitions.

Inlet and outlet connections for four-inch pipe are provided and there are large sludge and effluent compartments. Both inlet and outlet are protected with baffle plates and there is a proper baffle between the chambers. The entire head is removable, being held tightly in place with bolts.

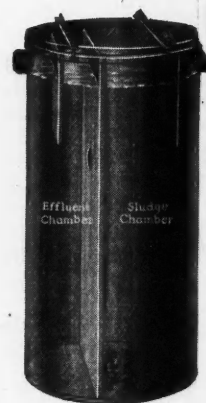

Septic Tanks of Copper Steel Alloy Are Proof Against Leaks.

You  
than  
the ne  
Vacu  
trade  
earnin

The Cl  
with or  
comple

der t  
to \$75

Plen

Every  
home  
halls  
havin  
ings  
desks  
office  
surfa  
more

The  
bad w

# This WINTER INSIDE WORK

*Pays \$25 to \$75 per Day*



You can make more money each day this Winter than you did any day the past Summer. How? In the new profession of finishing floors with the Clarke Vacuum Portable Sander. Hundreds of building trade workers and small contractors are making big earnings the year round with a Clarke.

system that sucks up the dust and shoots it right into the dust bag. Painting and varnishing can go on in the same room.

### Ease of Operation

The Clarke weighs 31 lbs. Operates from any electric light socket almost as easily as a vacuum cleaner. Because of its power and speed, it produces more superior work than the heavier, more cumbersome machines; it out-performs any sander made. With handle removed and smaller bag attached, it is especially handy in "tight" places—small closets, stairways, etc. On bench work and cabinet work it cannot be surpassed, for it does every kind of flat sanding from heavy duty roughing or planing to beautiful smooth fine cabinet finishes.

### A Money-Maker for You

For less than the cost of a good radio you can start in this profitable business and get into this big money right away. You are already experienced. The machine does the work—you merely guide it. The Clarke quickly pays for itself—so quickly that you cannot afford to neglect this golden opportunity. Get going! Write for the guaranteed facts, without obligation. Use the coupon today.

## Clarke Sanding Machine Co.

Dept. AA-312,  
3815 Cortland St., Chicago, Ill.

*Originators and, for over 12 years, Manufacturers of  
Portable Sanding Machines*

### INFORMATION COUPON

**Clarke Sanding Machine Co.,**

Dept. AA-312,

3815 Cortland Street, Chicago, Ill.

Gentlemen: Please send me, without obligation, your illustrated booklet, "Pointing the Way to Greater Profits," and full details about the money to be made in cold weather.

Name.....

Address.....

City.....

### Why the Pay Is High

For many years the finishing of floors and re-surfacing work has been done by hand or by slow cumbersome machines. So the rates have been based on antiquated methods. Contractors pay 3 to 5 cents per square foot for surfacing new floors; and correspondingly higher rates of 7 to 15 cents are paid for re-surfacing old floors. The improved Clarke is guaranteed to surface 900 to 2200 square feet of new floors or 300 to 1000 square feet of old varnished floors in 8 hours. No wonder the man with a Clarke



The Clarke can be carried anywhere with one hand—weighs only 31 lbs. complete.

knocks out \$25 to \$75 a day.

### Plenty of this Profitable Work

Every year shows hundreds of thousands of homes, apartments, stores, offices, assembly halls and public buildings badly in need of having their floors re-surfaced. New buildings need this service. Counters, benches, desks, doors, cabinets and all kinds of store, office, school and house equipment need re-surfacing. Once you start you will have more work than you can handle.

### Work in Bad Weather

The Clarke enables you to work indoors in bad weather because it has an inbuilt vacuum





### Safety Doors Protect Homes

THE safety door here illustrated in use combines in one single unit all four elements of the ordinary rear or front entrance—sash door, screen door, transom and transom screen. In addition to all this it offers the exclusive feature of adequate protection and security to the womenfolk and children of the household from bandits, morons or other intruders.

Instead of having to unlock and open the door to ascertain the identity and business of the caller outside, the housewife or servant in a house or apartment provided with this door needs only to open the secondary sash door. The 14 gauge steel grille and bronze insect screen allow adequate



With a Safety Door a Steel Grille and Bronze Screen Permit Vision and Conversation for Identification.

vision and conversation for complete identification before admission. Moreover, this door with the upper sash left open offers free ventilation with perfect safety at any time, day or night, while the permanent rustproof bronze screen keeps out mosquitoes and flies.

Builders are installing and dealers are stocking the safety door as a real essential to a modernly equipped up-to-date house or apartment. The safety grille comes too close to being an absolute necessity under present-day conditions for this door to be regarded as merely a passing fad or fancy in door styles. It is, also, a powerful selling point with prospective buyers

or tenants. The Eddystone Homes of the Albert W. Swayne Company in Chicago is the third major apartment building equipped throughout with safety doors by this successful builder.

The door comes in the plain grille, as shown in the illustration, for rear entrances and in decorative grilles of suitable and beautiful architectural design for front entrance doors.



### Oil Burner and Boiler in One Unit

A COMPLETE heating system, in which the oil burner is a built-in and integral part of the boiler, the whole being marketed as a single unit, has been announced. This heating system is the outgrowth of experience in the sale of a heat economizing device for use on oil burners applied to boilers designed for coal. This experience indicated that it would be logical to incorporate this device with a special combustion chamber and boiler to obtain maximum efficiency.

In designing the new unit it was possible to eliminate a number of parts that ordinarily have to be furnished because of the necessity of fitting an oil burner to many different types of boilers, it is stated. The line of units being produced is broad enough to cover the requirements of the entire domestic field including industrial boilers up to 15 h.p.

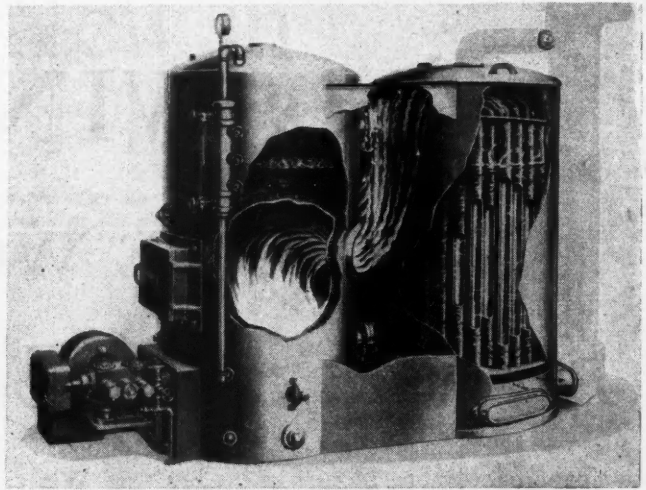

Oil Burner and Boiler in a Single Unit Which Provides for Maximum Fuel Economy.

The manufacturers of this unit claim that they have demonstrated that they can cut fuel costs upwards of 33½ per cent.

The line will also include gas fired industrial boilers and water heaters as well as gas burning boilers for domestic heating, incorporating the same economical features of construction as the oil burning boilers.



### The Radio Fireplace

THE radio fireplace is something unique which has been placed on the market recently. It offers an interesting piece of equipment to builders of homes and apartments, not only as a novelty but also as space saving equipment. It also makes possible a fireplace, for electric glow heaters or gas logs, at a low cost for both new and existing homes.

This new fireplace is of frame construction covered with fiber board. A plastic finish is applied to the fiber board and an unlimited range of tints and finishes are available.

The light weight construction reduces the shipping cost on these fireplaces to a minimum and they are so rugged that there is no danger of cracking or chipping either in shipping or in use. The installation can be made easily in about 30 minutes.

The radio feature is optional. It consists of a movable panel above the fireplace opening which conceals a compartment to receive the radio set. The tuning of the radio is done through a smaller movable panel in the large panel. With both panels closed the radio is absolutely concealed and the sound comes from the fireplace opening.

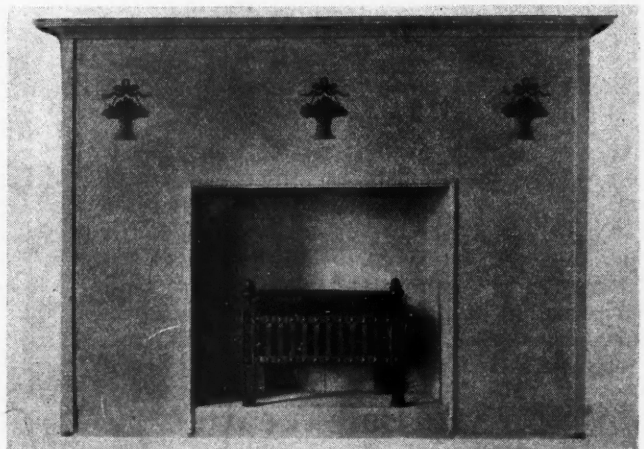

A Fireplace at Low Cost Which Can Be Installed in Any Home and Finished to Harmonize with Other Features.



# "The Performance of Our International Trucks is More Than Satisfactory"



## ... and Brick Hauling is One Tough Job!

**A**T Cannell Siding, eight miles from Edmonton, Alberta, Canada, are the clay pits and kilns of the Acme Brick Co., Ltd. Until recently that 8-mile haul constituted a real problem and a heavy expense; now the thousands of tons of brick and tile are hauled to town in International Trucks.

Although the loads are extraordinarily heavy, and the going is hard, the Internationals make five round trips a day, covering 16 to 20 miles each trip. The combination of low operating costs and maximum road speed has resulted in brick haulage figures far below previous costs.

Read the letter from the Acme Company and you'll find it filled with praise for International Trucks. Read between the lines and you will find the answer to your haulage problem. Trucks that will stand the gaff and reduce costs on "the hardest job in the world" will make a real showing on any kind of hauling you care to put them up against.

*International Harvester maintains complete stocks of trucks and parts in 174 Company-owned branches in the United States and Canada. Visit one of these branches and inspect the trucks themselves and the facilities back of them. Write to us for complete information. Truck sizes range from 3/4-ton Special Delivery to the big 5-ton Heavy-Duty Truck.*

"Gentlemen:

A brick company supplies the hardest job in the world for trucks. Immense loads must be rushed over all manner of roads in order to keep transportation costs at a minimum.

The performance of our International Trucks is more than satisfactory; our dual-tired HS-74, 3 1/2-ton truck, and SF-46, 2-ton trucks, are averaging four to five trips every day, with minimum hauls of eight miles each.

We are pleased with the service we have received from our trucks and will recommend them to any firm requiring trucks.

Yours truly,

ACME BRICK COMPANY, LTD.

(Signed) Robert Spencer,  
President

J. P. Henry,  
Supt. of the Plant."

## INTERNATIONAL HARVESTER COMPANY

606 So. Michigan Ave.

OF AMERICA  
(Incorporated)

Chicago, Illinois

**NEWS OF THE FIELD**

**Convention and Show Dates**

- Dec. 4-6, 1929.....National Paving Brick Manufacturers' Association, 24th Annual Convention, The Palmer House, Chicago.
- Dec. 6-7, 1929.....Two day Conference on church architecture under the auspices of the associated denominational bureaus and departments of architecture and architectural and manufacturers' displays, Statler Hotel, St. Louis, Mo.
- Jan. 11-18, 1930.....American Road Builders' Association, Annual Convention and Road Show, Atlantic City, N. J.
- Jan. 22-23, 1930.....Annual Business Meeting of the National Association of Real Estate Boards, Hotel Westward Ho, Phoenix, Ariz.
- Jan. 27-31, 1930.....International Heating and Ventilating Exposition, under the auspices of the American Society of Heating and Ventilating Engineers, Commercial Museum, Philadelphia, Pa.
- Feb. 4-6, 1930.....Second Annual Convention, Iowa Lumber & Material Dealers' Association and First Manufacturers' Co-operative Exposition, Shrine Temple, Des Moines, Iowa.
- Feb. 11-12, 1930.....American Concrete Institute, Annual Convention, Roosevelt Hotel, New Orleans, La.
- Feb. 16-20, 1930.....32nd Annual Meeting and Exhibit of the American Ceramic Society, Hotel Royal York, Toronto, Canada.

- Feb. 20-22, 1930.....New England Hardware Convention and Exhibition, Mechanics Bldg. Headquarters Hotel Statler, Boston, Mass.
- March 3-7, 1930.....National Industrial Equipment Exposition of the Midwestern Engineering Exposition, Inc., Hotel Stevens, Chicago.
- March 24-28, 1930....Building Officials' Conference of America, Annual Meeting, Cleveland, Ohio.
- April 5-12, 1930.....Ninth Home Complete Exposition, Indianapolis Real Estate Boards, Indianapolis, Ind.
- April 7-12, 1930.....Seventh Annual Convention and Oil Burner Show of the American Oil Burner Association, Hotel Stevens, Chicago.



**H. C. Houck Passes Away**

**H**ENRY C. HOUCK, manager of the merchandise department of the General Electric Company, died at his home in Bridgeport, Conn., on October 15 after a long illness. Educated at Phillips Exeter Academy and the University of Pennsylvania, from which he was graduated in electrical engineering in 1899, he entered the employ of the General Electric Company in the fall of that year. In his 30 years of service with the company Mr. Houck filled many important positions at Schenectady, Cleveland and Cincinnati, as well as Bridgeport.



**T. A. Carroll Passes Away**

**M**R. THOMAS A. CARROLL, advertising manager for E. C. Atkins & Company, Indianapolis, Ind., for the last sixteen years, died very suddenly, November 18.

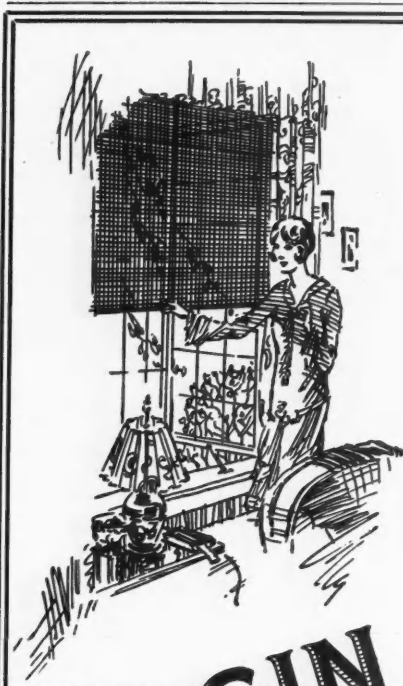

**It's the Screen of Screens!**

**You'll Appreciate Its Better Construction Instantly**

Here's a rolling screen that's as practical as it is convenient! Up or down it glides—just like a window shade. And it *continues* to operate, season after season, year after year.

Higgin *hinged* and *sliding* screens are well known in millions of American homes—and now Higgin is building a *rolling* screen . . . one that combines the features of ordinary rolling screens and adds certain *exclusive* sales points of its own! All exposed parts are copper-coated steel with statuary bronze finish. The mesh is Ana-

conda bronze cloth—almost invisible. Special automatic locking device, etc.

Cash-in on this opportunity. Your clients know that rolling screens eliminate Winter storing, repairing, installing, etc.—and they know that Higgin stands for super-quality . . . the *ultimate* in screens!

You'll find these improved screens as strong a selling point as an electric refrigerator or incinerator! Mail the coupon now for our illustrated booklet and complete information.

**THE HIGGIN MANUFACTURING COMPANY**

*Screen Specialists since 1893*

Home office

502 Washington Ave. - NEWPORT, KY.

Branch Factories at

KANSAS CITY, MO. - TORONTO, CAN.

**HIGGIN**  
ALL METAL  
**SCREENS**

The Higgin Mfg. Co.  
502 Washington Ave.  
Newport, Ky.

Please send complete information regarding your new rolling screen.

Name \_\_\_\_\_

Street \_\_\_\_\_

City \_\_\_\_\_ State \_\_\_\_\_

FOR ADVERTISERS' INDEX SEE NEXT TO LAST PAGE

Bui  
a M  
tan  
Tra  
You  
Qu  
Sal  
Bui  
Tra  
You  
Rea  
Pri  
tun  
SE  
A  
By  
E  
must  
Spec  
min  
Buil  
a lot  
alon  
T  
new  
bitio  
with  
fine  
is ar  
easy  
you  
and  
nece  
enot  
Pra  
S  
Y  
and  
you  
new  
meth  
and  
Buil  
ama  
thin  
the  
Buil  
of it  
for  
right  
time  
does  
don't  
tion  
you  
cip

# Wanted... Men To Read Blue Prints And Run Big Building Jobs!

**Builders! Here's a Message of Vital Importance to Every Ambitious Tradesman in America! To Help You Win Promotion in Building and Qualify You for Leadership at Man-Sized Salaries. This Old Established School for Builders Now Offers Quick, Easy, Practical Training in Plan Reading. Coupon Below Brings You Absolutely FREE a Valuable Book, "How To Read Blue Prints"; Also a Set of Real Building Blue Prints. Smart Builders Will Investigate This Opportunity. Write for Convincing Facts at Once!**

## SEE HOW QUICKLY YOU CAN BECOME A Superintendent Or Building Contractor By This New, Easy Blue Print Way To Big Pay

**E**VERY man in the Building Industry today knows that in order to win promotion and run big building jobs he must understand Blue Print Plans and Specifications from A to Z. With a trained mind it is easier to hold a big pay job in Building than it is to keep a job that pays a lot less and depends upon your hands alone.

This announcement spells wonderful news for every man who is practical, ambitious and who yearns for a real future with an income that will afford him the fine things in life he wants! Here at last is an opportunity for you to take a quick, easy step that will bring you the success you have hoped for—if you are of this type and are willing to supply the honest effort necessary. Remember, your spare time is enough.

### Practical Blue Print Training— Superintending—Estimating

You've needed it, you've prayed for it and now at last Chicago Tech brings it to you! For by a marvelous new practical blue print method, this old established and recognized School for Builders brings to you in an amazing short time everything you need to put you on the "headwork" side of the Building Industry. Think of it—you prepare yourself for big pay and a real future right in your own home and in your spare time—right while you are on the job! It doesn't matter what your age is. You don't even have to have previous education. If you can read what is written here, you can grasp every money-making principle easily.

#### If You Live Nearby

Visit our big Day and Evening School attended by over 1,000 builders. You can get the same training at home by mail—same lessons, same plans, same instructors—in your spare time.

#### No Textbooks—Simple as A.B.C.

The wonderful part about this astonishing blue print training is that it is entirely different from ordinary schooling. No study grind. No text books to wade through. No useless theory to puzzle you. Practical from start to finish. Based on many sets of real blue prints which we give you to examine and keep. Twenty famous experts go over these actual working plans with you step by step and explain everything in plain, everyday language you can easily understand. Fascinating throughout and as easy to understand as your newspaper.

#### A Better Job At Bigger Pay

This is the kind of training that has enabled builders throughout the country—practical, ambitious men like yourself—to make the kind of money they wanted. Samuel Schrier, Pennsylvania, reports that he has been raised to foreman with an increase of \$72.70 per week. W. Fout, Virginia, was promoted from workman to superintendent as a result of his training. Percy E. Blair, Oklahoma, writes: "When I started your course, I received \$49.50 per week working with my tools. Now I am superintendent and make \$100 a week for the same concern."

#### Mail Coupon For FREE Facts

Investigate this short-cut to promotion at once! Don't send one penny. Simply fill in and mail the coupon. It brings you promptly a valuable free book, "How To Read Blue Prints," and actual working blue prints as well as convincing proof. No cost or obligation. Get these important facts before you without delay, so that you may see for yourself how really easy and practical is Chicago Tech's Blue Print Method. Write today—NOW!

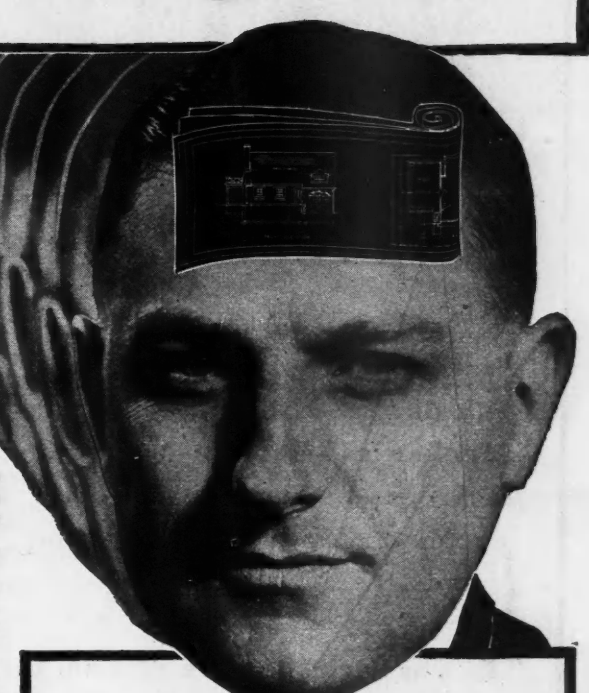

## FREE Books and Blue Prints To Carpenters and Builders!

Without cost or obligation, every ambitious, practical man may now secure a copy of "How To Read Blue Prints" and a set of valuable working blue prints. Also, full facts and details about the new easy at-home training that has made possible promotions and bigger pay checks for scores of builders all over the country. Remember—there is absolutely no risk for you, so fill in and mail the coupon below!



Chicago Technical School  
For Builders,  
Dept. R-122, Chicago Tech Building,  
118 E. 26th St., Chicago, Ill

Send me at once your FREE BOOK and complete set of FREE BLUE PRINTS which I understand are mine to keep without obligation. It is understood that no salesman will call on me.

Name.....  
Address.....  
City..... State.....  
Age..... Occupation.....

**Chicago Technical  
SCHOOL for BUILDERS**



Dept. R-122, Chicago Tech Building  
118 E. 26th St., Chicago, Ill.





**The FARRAND RAPID RULE—**  
**The Gift They're Proud to Show**  
 —Engineers, Architects, Builders,  
 Mechanics, Pattern-Makers,  
 Plumbers or Steam-fitters,—All  
 good craftsmen who use good  
 tools.

\*\*\*\*\*

Why not make more pleasant the  
 Christmas of some fellow crafts-  
 man with the gift of a  
**FARRAND RAPID RULE**

*Manufactured by*  
**HIRAM A. FARRAND, Inc., Berlin, N. H.**



FOR ADVERTISERS' INDEX SEE NEXT TO LAST PAGE

**Personnel Announcements**

**J**OSEPH T. RYERSON & SON, Inc., announces that Arthur C. Allshul, formerly manager of its Buffalo plant, has been appointed manager of the company's unit in the Philadelphia district. As previously announced, the Ryerson company has purchased the business, equipment and good-will of the Penn-Jersey Steel Company at Camden, N. J., and is also making other arrangements to provide adequate facilities for a comprehensive stock to meet the requirements of trade in the Philadelphia metropolitan district.



Arthur C. Allshul,  
 of Joseph T. Ryerson & Son, Inc.

Clarence S. Gedney has been appointed manager of the Buffalo plant to succeed Mr. Allshul. Mr. Gedney has been connected with the specialty sales division in the Chicago territory.

**I**T has been announced that James A. Boyer has been appointed head of the Cost Accounting Bureau of the American Paint and Varnish Manufacturers' Association, Inc., effective November 17.

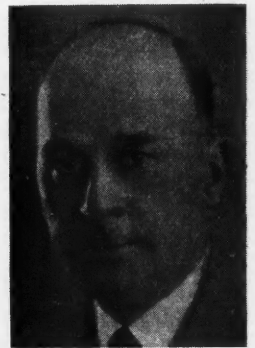

Clarence S. Gedney,  
 of Joseph T. Ryerson & Son, Inc.

**T**HE Consolidated Expanded Metal Companies, Wheeling, W. Va., announces the appointment of L. W. Sprickman as manager of its Buffalo, N. Y., office and warehouse. Mr. Sprickman is being promoted to fill the vacancy caused by the transfer of C. V. Vigor, former manager, to the main office of the company in Wheeling.

**T**HE Portland Cement Association, Chicago, announces the appointment of James R. Fairman as manager of its Eastern offices, with headquarters at 347 Madison Ave., New York City, succeeding B. H. Wait, who has resigned.

**Framing the Gambrel Roof**

*(Continued from page 105)*

**Roof No. 3:**  
 Pitch 40 degrees.  
 Total run not given.  
 Total rise is given as 80.56".  
 We may take the rise per foot run from table which is 10.07".  
 The total rise divided by the rise per foot run gives the total run.  
 $80.56 \div 10.07$  gives 8 as the run in feet.  
 Length per foot run is 15.66".  
 Length is  $15.66 \times 8 = 125.28"$  or  $10'-5\frac{1}{4}"$ .  
 Cuts are 40 and 50 degrees.

**Roof No. 4:**  
 Rise per foot run is 25.73".  
 Total rise is  $25.73 \times 10\frac{1}{2} = 270.16"$ .  
 Length per foot run is 28.39".  
 Length is  $28.39 \times 10\frac{1}{2} = 298.095"$  or  $24'-10\frac{1}{8}"$ .  
 Cuts are 65 and 25 degrees.

**Roof No. 5:**  
 Total rise is  $4.37 \times 18 = 78.66"$  or  $6'-6\frac{5}{8}"$ .  
 Length per foot run is 12.77".  
 Length is  $12.77 \times 18 = 229.86"$  or  $19'-1\frac{7}{8}"$ .  
 Bottom cut 20 degrees. Plumb cut 70 degrees.

# SKILSAW

## the original electric hand-saw

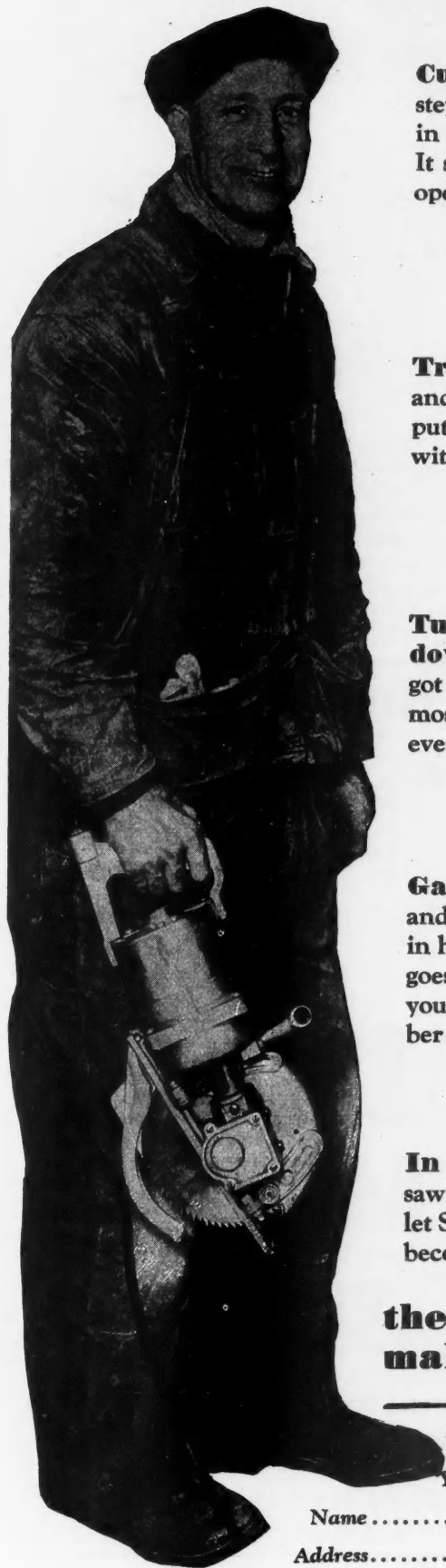

**Cut a stair stringer** of 16 steps out of 2' lumber complete in twelve minutes with Skilsaw. It saves as much time on other operations too.



**Trim a door fast,** accurately and so neatly you won't need to put a plane to any edge. Skilsaw with a mitre blade will do it.

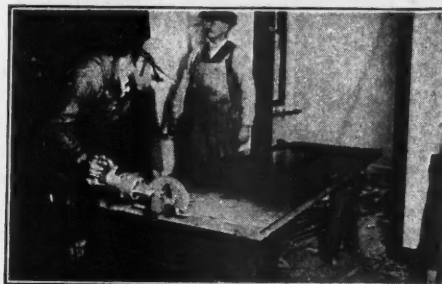

**Turn SKILSAW upside down** on a bench and you've got one of the fastest cutting and most powerful table saws you'll ever need.

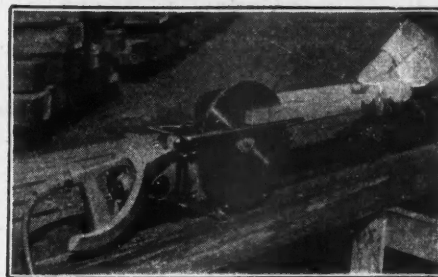

**Gang the work** for Skilsaw and you'll make concrete forms in half the time because Skilsaw goes to the work, anywhere—you don't have to carry the lumber to Skilsaw.



**In tight places** where hand-sawing is inconvenient and slow let Skilsaw do the work. It then becomes a fast easy job.



**the SKILSAW way makes sawing pay**

SKILSAW, INC., Dept. 4  
3310 Elston Avenue, Chicago, Illinois

Yes, I'll watch a five minute demonstration of Skilsaw. This doesn't obligate me at all.

Name .....

Address .....

WHEN WRITING ADVERTISERS PLEASE MENTION THE AMERICAN BUILDER

### Books, Bulletins and Catalogs for You

**T**HE literature and publications listed here are available to the readers of *American Builder*. They may be obtained from the firms mentioned and will be forwarded without cost except where a price is noted.

The National Steel Fabric Company, Union Trust Bldg., Pittsburgh, Pa., has published a new booklet, "Better Walls for Better Homes," which deals with the subject of "How Steeltex Solves Four Wall Problems of Plaster and Stucco Walls; Reinforcing; Damp-proofing, Insulating and Sound Deadening."

The Truscon Steel Company, Youngstown, Ohio, has published a booklet, "Erection Data and Specifications on Truscon Ferrobord Armco Ingot Iron Roofdeck," which is gotten out for the practical roofer and roofing contractor and covers the installation of Ferrobord roof deck.

The United States Steel Corporation, New York City, has published a book on the "Products and Publications of the Subsidiary Manufacturing Companies of the United States Steel Corporation," which is a complete directory of these companies.

The Associated Metal Lath Manufacturers, 1821 Engineering Bldg., Chicago, have issued a new booklet containing both specifications and detail drawings pertaining to all forms of metal lath construction. This is an enlarged and revised edition of former specifications and brings up to date a study of all types of metal lath construction. It is written in practical form so that architect and contractor can adapt it to his own use.

"1929 A. S. T. M. Tentative Standards" has been published by the American Society for Testing Materials. This is the 1929 edition of this book which is published annually. It comprises 901 pages and contains 173 tentative standards on

a wide range of products. Price \$7 in paper and \$8 in cloth binding.

The Savogran Company, India Wharf, Boston, Mass., offers an interesting circular of its Savogran crack filler used for flooring, furniture, paneling, trim and all kinds of woodwork.

"Save Fuel with Winter Windows" is the title of a booklet published by the Libbey-Owens Glass Company, Toledo, Ohio, showing the increased comfort and savings in heating cost obtained by the use of extra windows placed outside the regular windows.

Sargent & Company, 51 Water St., New Haven, Conn., has published a new booklet "Modern American Designs in Sargent Hardware," which presents in an attractive manner these new products.

"From Rock to Roof" is a new booklet published by the Pennsylvania Slate Institute, Pen Argyl, Pa., containing "The story of how natural rock is fashioned by hand into the most durable and distinguished of roofings."

The Department of Engineering Research, University of Michigan, Ann Arbor, Mich., has published an Engineering Research Bulletin No. 13 on "A Practical Method for the Selection of Foundations Based on Fundamental Research in Soil Mechanics," by W. S. House.

"How to Build Your House with Steel Framing" is a booklet by L. Brandt, Housing Engineer, Pittsburgh, Pa., which was prepared after an intimate contact with the Steel Frame House Company's system of framing since its inception. The information was obtained in practical experience and also in placing contracts and observing the handling of steel frame house construction in many sections of the country.

The Diagraph Stencil Machine Corp., 2915 Clark Ave., St. Louis, Mo., has prepared a new booklet, "Shipper's Handy Helper," which contains much helpful shipping information and a listing of nearly 100 shipping room items.

## Know Perfect Incineration!

### Investigate **SECO** Improvements

Exhaustive research and experiments evolved the features which make SECO the outstanding incinerator for modern construction. No other incinerator can offer all the practical features of SECO. Its special "Impact Breaker" (Patent applied for) and "Secondary Air Supply" are revolutionizing incineration. The Impact Breaker deposits the refuse lightly and loosely—it eliminates hammering and packing of refuse upon the grates. The Secondary Air feature provides a strong steady circulation of air around and through the garbage and insures its rapid and complete reduction. The fact that it is designed to obtain very high temperature is responsible for perfect combustion—but the SECO Incinerator is the best obtainable even without these improvements.

[Consult your telephone directory (under listing Seco Incinerators) for the name of your local Seco dealer.]

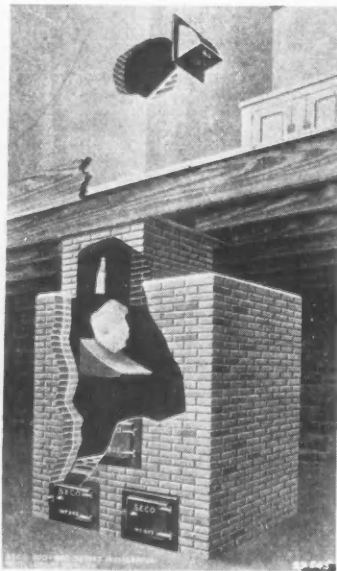

**Seco Incinerator Company**  
3714 Main Street, Kansas City, Mo.

(Bricked-up types, portable metal types, ranging in price from \$55 up.)

## Bommer Spring Hinges

are  
the best

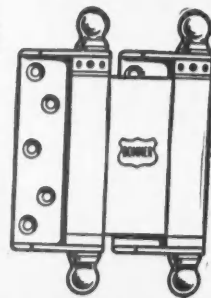

are  
the best

# Millions and Millions

of People are Pushing

## Them

whenever they open a door

Follow the line of least resistance

Use **Bommer** Always

They are the best

Bommer Spring Hinge Co., Brooklyn, N.Y.



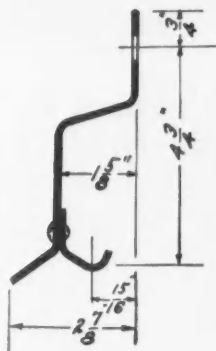

Cross section of "Glide" Track with dimensions. Shows simple construction. Note wide, free runway for hangers.

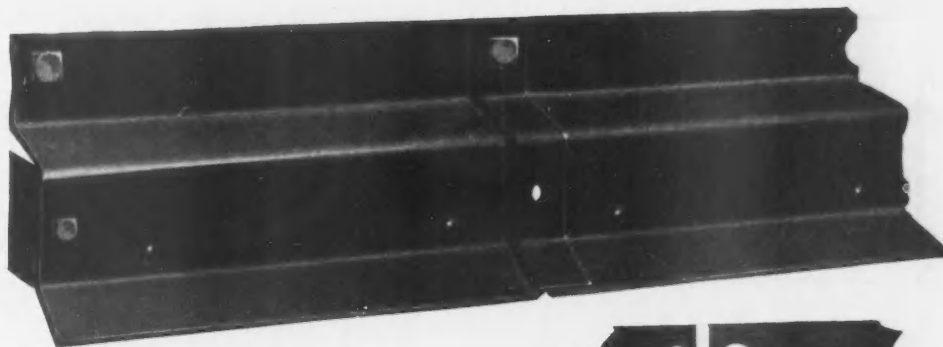

## "Glide" Assures Trouble-Free Operation the Year 'Round

"Glide," the original watershed track, was designed to give long, satisfactory service. Every possible detail of this track and its hangers, has been perfected to the highest point of efficiency.

The following convenience and long wear features have made "Glide" an outstanding hanger and track value.

1. "Glide" Track is complete in one piece. No brackets, or bracing required. Easy to install.
2. "Glide" will carry doors of any thickness without blocking away from the building—the hanger bolts to the inside of the door.
3. "Glide" Track is formed from special analysis wrought steel famous for its weather resisting qualities.
4. The wheel tread of "Glide" Track is shaped to minimize friction.
5. "Glide" Hangers have steel roller bearings and axles for easy operation.
6. "Glide" Hangers and Track cost no more than ordinary equipment.

No Hardware  
is Genuine  
**FRANTZ**

QUALITY  
without the  
Red Label

Frantz Dealers will gladly demonstrate "Glide" and other Frantz Hangers and Tracks to you. The chart, "How to Select the Correct Hanger and Track for Any Door," will help you specify the best and most economical equipment for doors. It is sent FREE—use the coupon below!

**FRANTZ MFG. CO.**  
STERLING, - - ILLINOIS

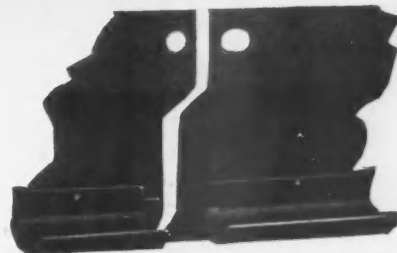

This patented telescoping joint makes two or more lengths of "Glide" Track operate like one continuous piece. No joint brackets or splices are required.

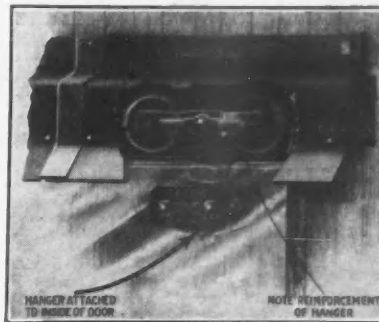

"Glide" Hanger No. 2 provides easy adjustment for raising the door in case the floor is raised by frost or the building sags. Has steel roller bearings and axles.

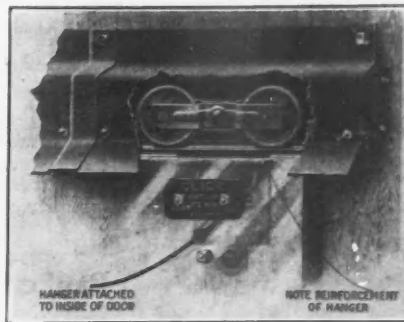

"Glide" Hanger No. 1 is easily installed. The hinged drop strap allows door to swing out at the bottom when bumped. Has steel roller bearings and axles.

THE "HANGER and TRACK CHART" IS SENT FREE—Mail This Coupon

**FRANTZ**  
TRADE MARK  
*Guaranteed Builders Hardware*

Frantz Mfg. Co., Dept. A-1, Sterling, Ill.  
Kindly send me the "Hanger and Track Chart" that will help me to select the proper equipment for any door. Also send me the name of the nearest Frantz Dealer.

Name.....  
Address.....  
City..... State.....  
My Hdwe. Dealer is.....