

CIRCULATE
UNIVERSITY OF HAWAII

The Architectural

FORUM

Magazine of Building

Copy 2



A home with

Suntile

is a home with ● BETTER TILE

● BETTER INSTALLATION

Any home is a better home if it has Suntile in bathroom, kitchen, foyer, patio.

You assure *two* things for any home you design when you select Suntile:

Better Tile. Suntile's extra quality in form and finish is achieved through rigid manufacturing control. Suntile's *color-balance*—a distinctive feature which makes harmonious blends so easy to achieve—is the result of scientific color measurement and selection.

Better Installation. Authorized Suntile dealers, carefully selected and trained, see to it that every

Suntile installation reflects the excellence of the product they represent and the wisdom of your own selection.

For better tile—better installation, let us send you the name of an Authorized Suntile Dealer. He can show you real clay Suntile in 16 wall colors. In addition, he can show you impervious unglazed ceramic mosaic Suntile in 15 colors—and Suntile Camargos in 10 colors—both in modular sizes.

See Sweet's Catalog for more complete information. The Cambridge Tile Manufacturing Company, Cincinnati 15, Ohio.



COLOR BALANCED

Suntile

..... A real clay tile
.... Bright with color
..... Right for life



Suntile OFFERS YOU BOTH—*Better Tile.... Better Installation*

Winner of Modern Plastics Award
for Furniture and Interior Decorating Material
(7th Annual Modern Plastics Magazine Competition)

Kalistron

COLOR FUSED TO UNDERSIDE
PLASTIC COVERING MATERIAL

Making decorating history!

Kalistron is the new name for improved *Blanchardized* Vinylite®. It successfully combines in one material three attributes of importance to architects—beauty . . . durability . . . versatility.

It is equally suitable for fine furniture, living room or office walls, restaurant seating, corridor wainscoting, counters, elevators. It affords the designer unlimited possibilities to coordinate walls with furniture upholstered in the same material.

Prize-winning Kalistron starts as a transparent sheet of special Vinylite Plastic. Color is fused to the *underside* and glows thru the plastic with a richness and depth never obtainable before.

And because Vinylite Plastic guards the color, Kalistron is practically mar-proof. It won't scuff, scratch, chip, crack or peel . . . strong recommendations for using it wherever extreme resistance to wear and staining are essential.

Kalistron tailors beautifully. It drapes and shapes well around corners, curves and edges . . . handles easily . . . and is exceptionally soft and pliable.

Wherever beauty and durability must go hand in hand—specify Kalistron. It is available in a wide range of colors, including decorator shades and tints. Special colors to match your specifications are also available at a slight additional cost.

®Registered Trade Mark

Distributed by . . .

UNITED STATES PLYWOOD CORPORATION, 55 West 44th St., New York 18, N. Y.
and by: DECO SALES DIVISION, 410 Frelinghuysen Ave., Newark 5, N. J.

three things to remember about Sound Conditioning...

first: THAT NO NEW BUILDING IS MODERN WITHOUT IT...

Today it is known that noise and poor hearing conditions make people uncomfortable and lower their efficiency. This has made sound conditioning as important as good lighting in the specifications for modern buildings—commercial, school, hospital, or church. *That is why the number of new building installations of Acousti-Celotex sound conditioning has more than doubled in the last two years.*

second: THAT IT MAKES OFFICE SPACE EASIER TO RENT...

A building with Acousti-Celotex sound conditioning is easier to rent because it provides a better working environment—reducing employee fatigue, increasing accuracy and insuring a greater volume of work. *This is one of the reasons why more buildings of all kinds have been sound conditioned with Acousti-Celotex* products than with any other material.*

third: THAT SOUND CONDITIONING MATERIALS ARE NOT ALL ALIKE...

Two materials may have identical Noise Reduction Coefficients, yet differ widely in use and application. Celotex acoustical products include materials for every type of noise reduction or acoustical correction problem. *That is where our quarter century experience in sound conditioning may be a real help to you...in selecting the right product for a particular specification.*

YOU ARE INVITED to submit your acoustical problems to a trained sound technician—your nearest distributor of Acousti-Celotex products.

His judgment gives you the benefit of the accumulated skill of a quarter century in sound conditioning. Write us for the name of your nearest distributor in the United States or Canada. In the meantime, you'll find Acousti-Celotex products listed in Sweet's File, Section 11-A3. Sound conditioning is a sound investment.

* REG. U. S. PAT. OFF.

THE CELOTEX CORPORATION, CHICAGO 3, ILLINOIS



ACOUSTI-CELOTEX

TRADE MARK REG. U. S. PAT. OFF.

Sound Conditioning

PRODUCTS FOR EVERY SOUND CONDITIONING PROBLEM

The Architectural **FORUM**
MAGAZINE OF BUILDING

OCTOBER 1948

Published by TIME Incorporated

EDITOR-IN-CHIEF.....Henry R. Luce
PRESIDENT.....Roy E. Larsen
EDITORIAL DIRECTOR.....John Shaw Billings

The Architectural FORUM

MANAGING EDITOR
Henry Wright

ASSOCIATES: Eleanor Bittermann (Research), Louise Cooper, Walter McQuade, Harry J. Middleton, Mary Mix, Mary Sanders, Richard Saunders (Washington), Madelaine Thatcher, Lawrence W. Mester (Production).

ASSISTANTS: Wilson Dizard, Doris Hoffer, Sighe Kennedy, Rosalind Klein, Mary Jane Lighthown, Alice O'Connor, Amnon Rubinstein, Helen Benz Schiavo.

ART DIRECTOR: Paul Grotz.

CONSULTANTS: Miles L. Colean, George Nelson.

BUSINESS MANAGER: Vernon Hitchcock.

CIRCULATION MANAGER: George Seufert.

ADVERTISING DIRECTOR
GEORGE P. SHUTT

The Architectural FORUM is published monthly by TIME Inc., 350 Fifth Ave., N. Y. 1, N. Y. Subscriptions may be sent to 540 North Michigan Avenue, Chicago 11, Ill. Address all editorial correspondence to 350 Fifth Ave., N. Y. 1, N. Y. Yearly subscription payable in advance. To Firms and Government departments, their supervisory employes and design staffs, engaged in Building—construction, design, finance, real estate ownership or management, materials distribution and professional instructors and students: USA, Possessions and Canada, \$5.50; Pan American Union and the Philippines, \$9.00; Overseas countries, \$12.00. To those not connected with the Building Industry: USA and Foreign, \$12.00. Single copies, if available, (except Reference Numbers), \$1.00. Reference Numbers, \$2.00. All copies mailed flat. Copyright under International Copyright Convention. All rights reserved under the Pan American Copyright Convention. Entered as Second Class Matter July 17, 1944 at the Post Office at New York, N. Y., under the act of March 3, 1879. Copyright 1948 by TIME Inc.

TIME Inc., Time and Life Bldg., Rockefeller Center, New York 20, N. Y., also publishes TIME, LIFE and FORTUNE, Chairman, Maurice T. Moore; President, Roy E. Larsen; Vice President & Treasurer, Charles L. Stillman; Vice President & Secretary, D. W. Brumbaugh; Vice President & Sales Director, Howard Black; Vice Presidents, Allen Grover, C. D. Jackson, P. I. Prentice; Comptroller & Assistant Secretary, Arnold W. Carlson; Production Manager, N. L. Wallace; Circulation Director, F. DeW. Pratt. Producer, THE MARCH OF TIME, Richard de Rochemont.

VOLUME 89, NUMBER 4

NEWS	11
LETTERS	28
FORUM	44
ANNOUNCEMENTS	48
PROGRESS IN ST. LOUIS	69
The American Stove Co. puts up an enlightened administrative headquarters and sales display building. Harris Armstrong, architect.	
GREENE & GREENE	80
A discerning study of the almost forgotten California work of the Greene brothers by Jean Murray Bangs.	
MAINTENANCE BASE	90
The Austin Co. designs and builds an assembly-line west coast maintenance base for United Air Lines.	
MOVIE THEATER	95
A prototype for rural areas, semi-prefabricated and erected at low cost. Sebco Inc., designer and builder; George Becker, architect.	
HOUSES	96
Cliff house in Canada by Sharp & Thompson, Berwick, Pratt, architects. House in Florida by Twitchell & Rudolph, architects, and Lamolithic Industries, builder. A small development of concrete houses by same team.	
PRODUCTS & PRACTICE	109
Construction methods on the Lamolithic houses in Florida . . . European wall and floor covering . . . Air-entraining agent for concrete.	
BUILDING REPORTER	116
Low-cost prefabricated closet . . . Sliding closet door . . . Two-inch solid partition system.	
TECHNICAL LITERATURE	148
Copper . . . Lighting . . . Basementless Construction . . . Concrete Hardener . . . Windows.	
REVIEWS	158
Painting Toward Architecture . . . Santa Barbara Adobes . . . The Modern House Comes Alive.	

Cover photo (American Stove Building); Hedrich-Blessing.

HOW FENCRAFT *finer windows*

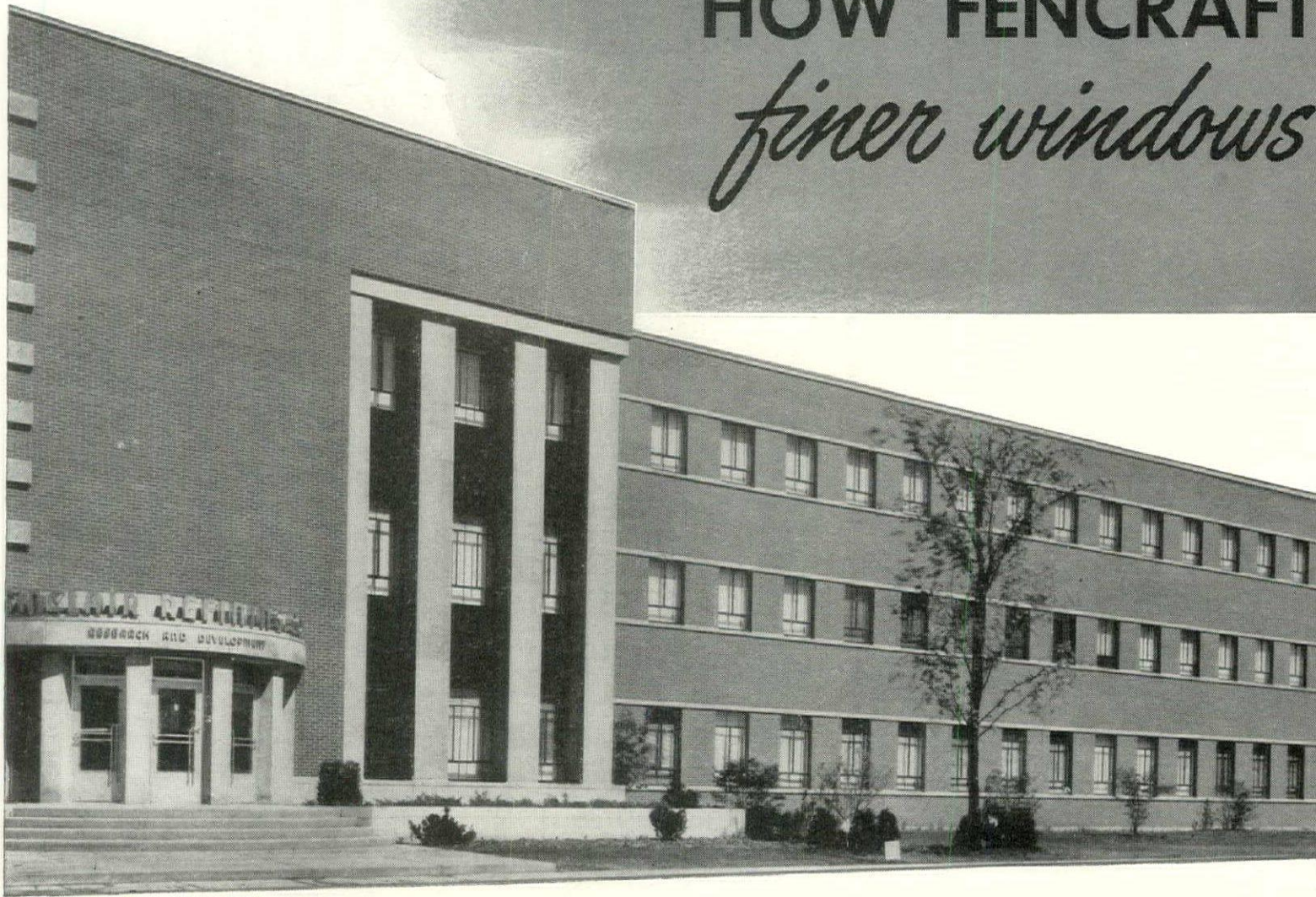

For Office Buildings...

Research & Development Building, Sinclair Refining
Company, Harvey, Ill.
Engineers and Contractors: The Austin Company
428 Fencraft Windows

Fencraft Windows were designed to provide the quality you want in buildings of character . . . and to help you solve today's problem of costs.

Standardization makes it possible to achieve this double goal. For standardization of types and sizes permits manufacturing efficiency. That means lower unit cost. It results in lower installation costs, too—for Fencraft Window dimensions are co-ordinated with those of collateral wall materials. Standardization both simplifies and speeds construction.

These are, without reservation, the finest windows we have ever built. We've applied our long experience

in designing top-quality casement sections, and used the finest materials and workmanship, to produce, in Fencraft, windows in keeping with the finest buildings.

Here's beauty—in graceful lines and fine hardware. Durability—in strong steel sections and carefully fitted parts. Utility—in easy screening, safer washing, firesafety, better daylighting and controlled ventilation.

These are good reasons why architects are specifying Fencraft Casement, Projected and Combination Windows for all types of buildings. For full information on Fencraft types and sizes, mail the coupon.

FOR ALL TYPES OF BUILDINGS...

Made by America's oldest and largest
Steel Window Manufacturer

GAVE THESE ARCHITECTS *at Lower Cost*

For Schools...

Little Flower School,
San Antonio, Texas

Architects:
Julian & White, San Antonio

Contractor:
Lynn & Morsey, San Antonio
221 Fencraft Windows

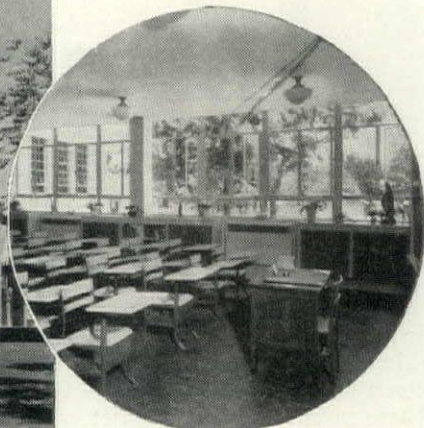

For Hospitals...

Annie M. Warner Hospital,
Gettysburg, Pa.

Architect:
John B. Hamme, York, Pa.

Contractor:
Earl L. Gump, Chambersburg, Pa.
86 Fencraft Windows

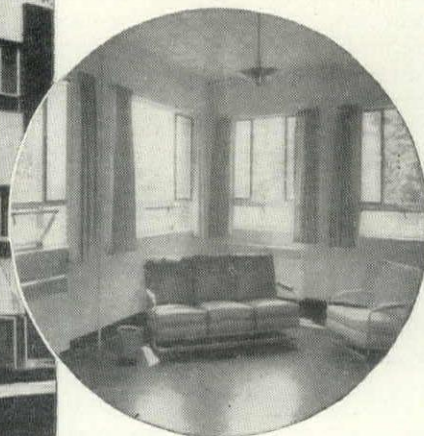
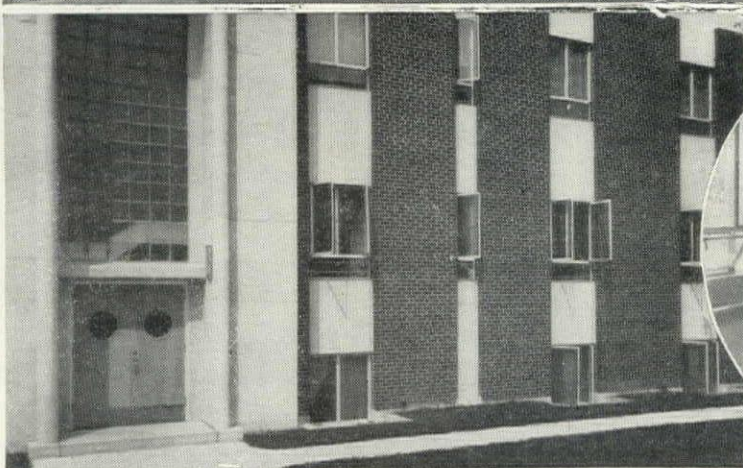

For Industrial Buildings...

L. C. Smith & Corona, Syracuse, N. Y.

Architect: Carl W. Clark, Cortland, N. Y.

Contractor: J. D. Taylor Construction Corporation, Syracuse
1214 Fencraft Windows

Fenestra

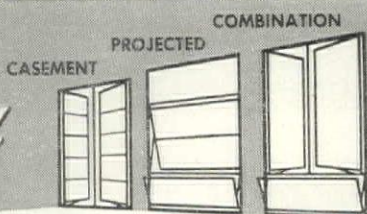

FENCRAFT INTERMEDIATE STEEL WINDOWS

Detroit Steel Products Company,
Dept. AF-10,
2251 East Grand Blvd.,
Detroit 11, Michigan

Please send me data on types and sizes of the
new Fencraft family of Fenestra Windows.

Name _____

Company _____

Address _____

THE **LUSTRON** HOME

REG. U. S. PAT. OFF.

Putting it up

PICTURE STORY OF THE ERECTION OF A LUSTRON HOME

Here are actual photographs of a Lustron builder-dealer's crew erecting a new Lustron Home.

These pictures show you, better than words could describe, the engineering "know-how" which brings production-line efficiency to the home building field.

America's first truly volume-produced house combines strength of steel and permanent beauty of porcelain in a home which offers more people "a new standard for living."

Although there are not nearly enough Lustron Homes to go around, you will soon be seeing more and more scenes like this. Watch them build those Lustron Homes!

© L. C.

LUSTRON CORPORATION, Box 2023K, Columbus, O.

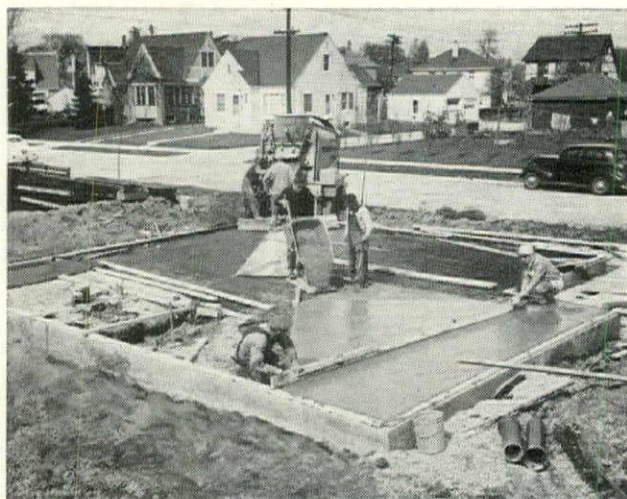

1 *Pouring the floor slab. Four inches of concrete, reinforced with steel wire, rests on six inches of gravel. Insulation between slab and foundation helps prevent cold floors in winter, adds to economy of heating the house.*



2 *Wall section goes up on site. Wall section is welded at factory, arrives ready to be set in place. Wall structure is bolted to foundation.*

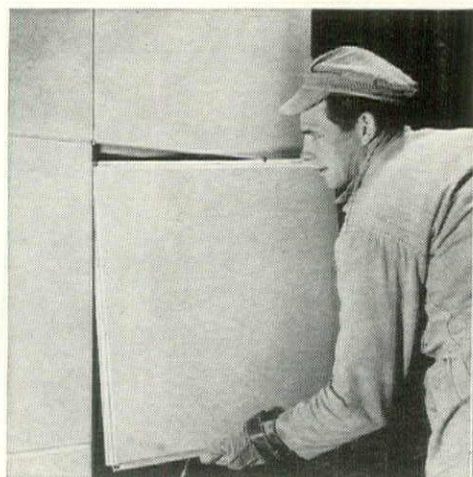

6 *Weather-tight exterior panels interlock, carry permanent fireproof insulating material which is made integral with panel at factory. Porcelain enamel surface has been fused to steel panels in world's largest continuous heat furnaces at 1300° F. temperature. This means the Lustron Home never needs repainting, redecorating, or reroofing. It can be kept clean with a damp cloth. Sun, smoke, salt water cannot fade panels.*

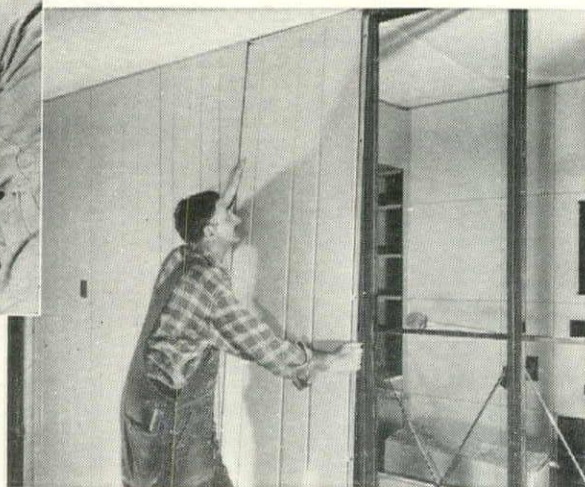

7 *Interior panels lock into place. These panels are also porcelain enameled steel, available in several beautiful subdued colors, which makes Lustron a home with great appeal to women. It is a home of cheerful convenience, with ample facilities for storage in the many built-in shelves, drawers, closets, and cupboards.*

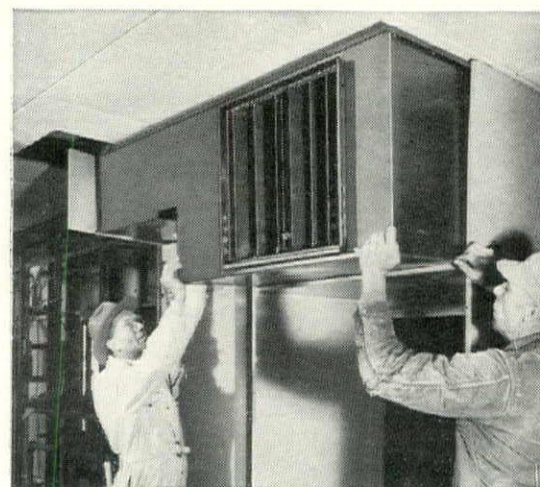

8 *Automatic heating unit—the efficient heart of Lustron's radiant panel heating system—is lifted into place. Unit is located at ceiling, takes up no floor space. Ceiling panels distribute heat rays evenly to all parts of house. No circulating currents of warm, dusty air; no unsightly radiators or grilles.*

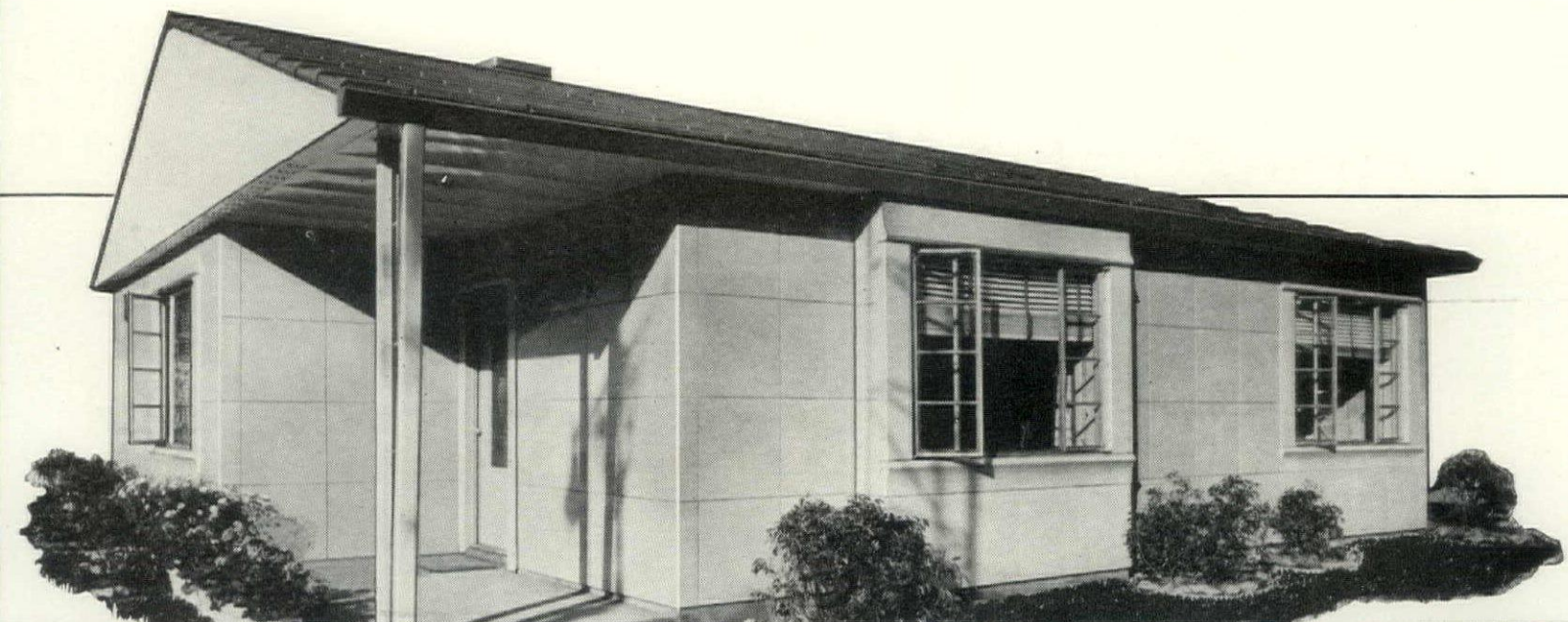

3 *Roof trusses rise over wall structure.* These two-section trusses are assembled during the erection procedure; truss is raised in place after sections are bolted together.

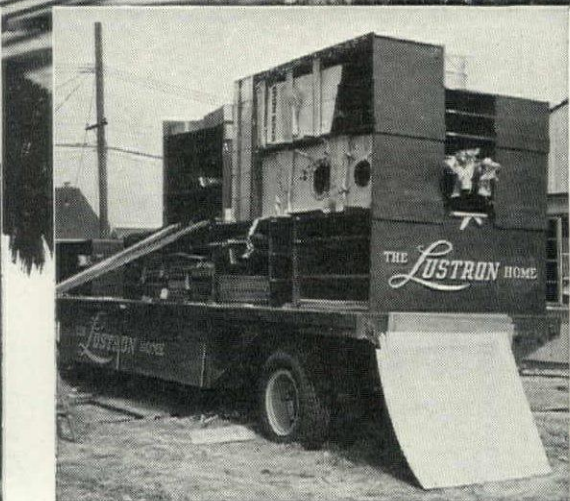

4 *Materials ready as needed. Big trailers* provide unit shipment from factory to site. Wall and roof sections have been removed from trailer; panels can now be taken from compartments.

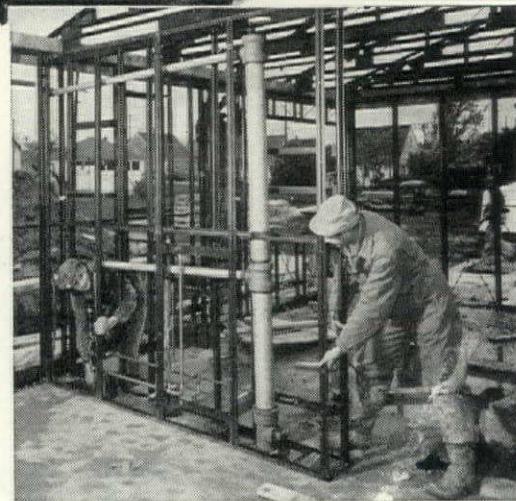

5 *Single-unit plumbing wall structure* comes just this way from the factory, ready to set in place. All interior plumbing and electrical switch box are centered at this point.

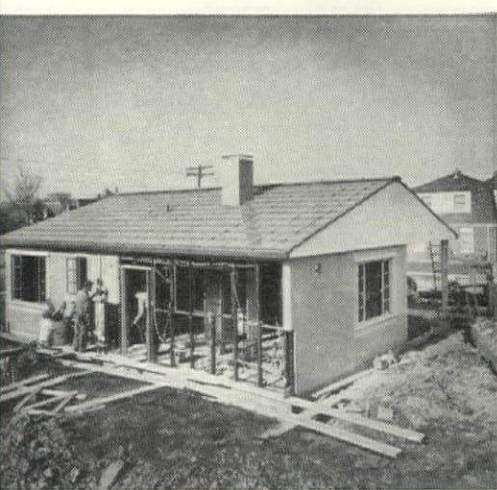

9 *Almost finished! As soon as roof is* placed, carpenters, plumbers and electricians can work simultaneously to expedite completion of house. Lustron builder-dealers keep crews in continuous operation, without delays or layoffs. This puts quick turnover into home building.



10 *"We want one of our own!"* 90.4% of people interviewed at Lustron Exhibit Homes approved the house enthusiastically. Efficient floor plan and room arrangement mean easy housekeeping, especially attractive to young people just starting home ownership. Price is well within means of average family.

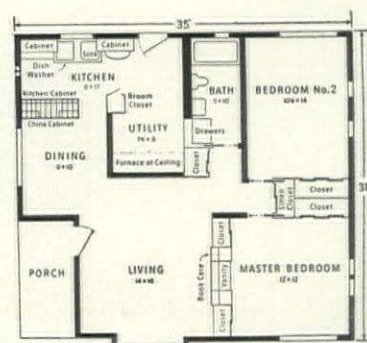

There are no

**IFS,
ANDS,
OR
BUTS**

**about keeping warm this winter
when you specify**

Automatic Anthracite Equipment...

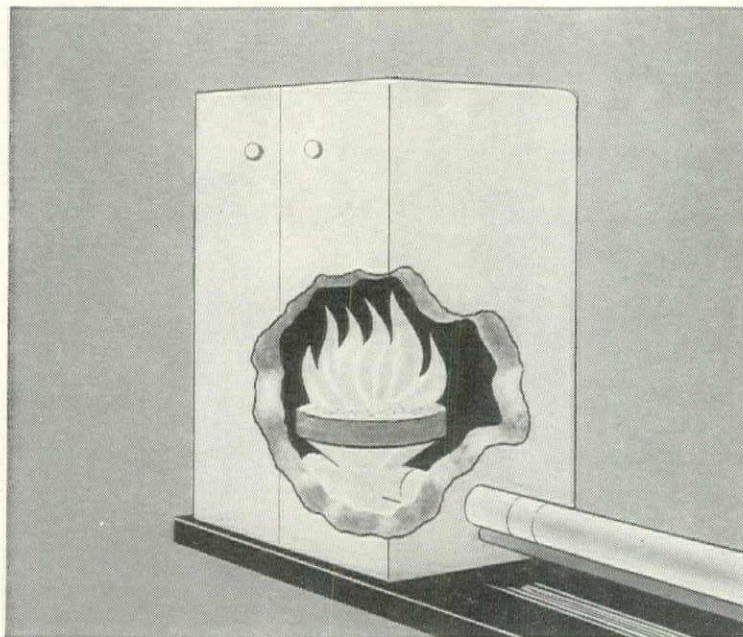

**AUTOMATIC ANTHRACITE
STOKERS**

When installed in an existing boiler or furnace and in new houses, reliable automatic hard coal stokers quickly deliver *plenty* of steady, comfortable heat . . . save up to 50% on fuel bills . . . eliminate fuel worries.

Home owners won't have to keep thermostats turned down to the uncomfortable 60's and 70's to conserve fuel. They can have *all* the heat they want, *when they want it!*

*Approved
Automatic
Anthracite Stokers*

ALLEN STOKER
ANCHOR STOKER
CATSKILL STOKER
COOPER STOKER
ELECTRIC FURNACE-MAN

FAIRBANKS-MORSE STOKER
FUEL SAVERS STOKER
IRON FIREMAN
MOTORSTOKOR
STEWART-ROGERS STOKER

VAN WERT STOKER

Here's the best answer to shortages of other fuels and soaring costs!

Regardless of the heating requirements of your houses, there's an anthracite heating unit to fill your needs.

Automatic anthracite heating equipment cuts fuel bills! This is an important fact these days of soaring costs. Important to you, the architect . . . important to the home owner.

Anthracite is in no danger of short supply. There will be plenty of hard coal to keep owners of your houses warm and comfortable this winter and for years to come.

A whole winter's supply of hard coal can be stored easily. This eliminates all worry about fuel for the entire cold season.

Home owners want clean, comfortable, economical, worry-free heat—and plenty of it! They have *just that* when you specify automatic anthracite heating equipment.

✓ ✓ ✓

Look over the two main types of automatic heating equipment shown here then get more detailed information from us.



ANTHRACITE INSTITUTE

101 Park Avenue

New York 17, N. Y.

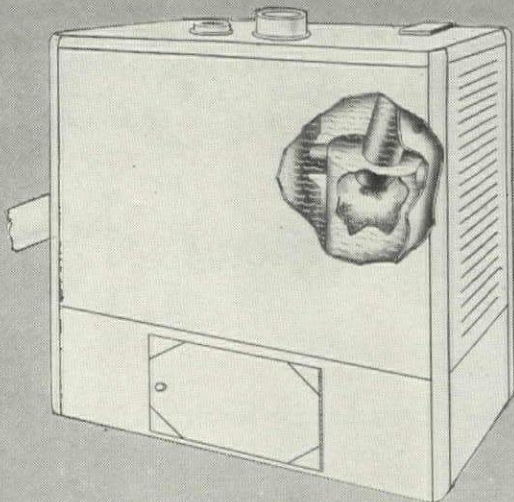

THE REVOLUTIONARY ANTHRATUBE

The Anthratube saves up to 38% on fuel bills. Its proven efficiency is over 80%. This compact design with "Whirling Heat" and other revolutionary features, produces quicker response and superior performance compared with heating units using other types of fuel.

This unit burns an economical size of plentiful anthracite. It's completely automatic from bin feed to ash removal. It delivers up to 130,000 B.T.U's.

Approved
Manufacturers
of the Anthratube

AMERICAN BOILER WORKS
AXEMAN-ANDERSON COMPANY
BETHLEHEM FOUNDRY & MACHINE CO.

NOW... EASIER KITCHEN PLANNING THE KELVINATOR WAY!

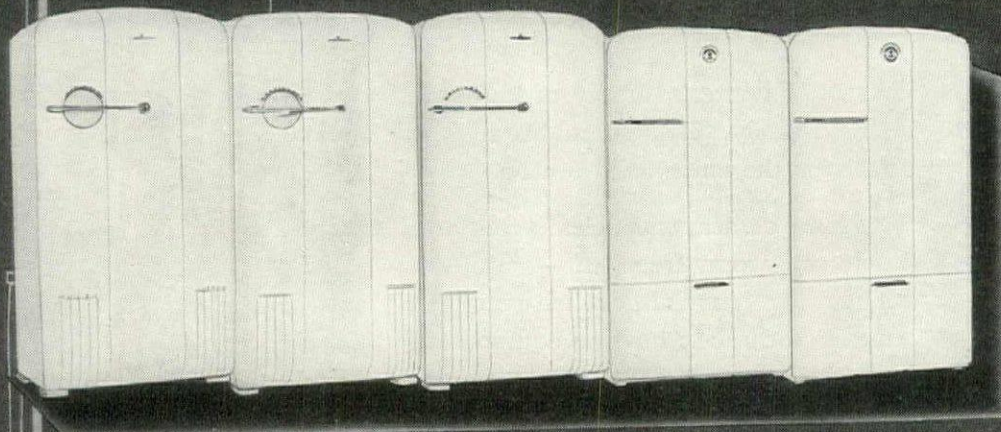

**5 Refrigerators
7 cu. ft. and larger
all one width!**

**4 Ranges and
Home Freezer
all one width!**



Just pick your model by budget...

NO CHANGE IN FLOOR PLANS NEEDED!

Choose any combination of top-quality Kelvinators. Regardless of size, 5 new Kelvinator Refrigerators are all 31¼ in. wide. Regardless of model, 4 new Kelvinator Ranges and the new Kelvinator Home Freezer are all 39 in. wide. . . . Only Kelvinator offers the flexibility of uniform widths for easier kitchen planning!

Kelvinator—of Course!



For Smaller Kitchens . . .

**"Space-Saver" Package Gives Small Kitchens
Big-Kitchen Advantages!**

"Space-Saver" Refrigerator, only 24" wide, is full 6 cu. ft.—holds 50% more than the prewar model of identical outside dimensions. Companion range is only 21" wide—new design permits installation flush against the wall. Stars a full-size oven . . . three new, Electric-Fast, tilt-up surface units—one 8", two 6". Kelvinator quality throughout.

For further information, write Kelvinator Division,
Nash-Kelvinator Corporation, Detroit, Michigan.

NEWS

WASHINGTON

FHA terms speed rental projects, but \$6,000 house lags p. 11

Remodeling loan curb p. 12

PREFABRICATION

Reliance clinches loan p. 12

PRICES

Revised tax policy on plant depreciation would help p. 12

MATERIAL

More standardization needed for low-cost house p. 13

JOBS

UN plans go out for bids p. 14

PAN-AMERICA

Cuba's big house job p. 14

DESIGN

First Wright-planned community is being built p. 16

BUILDING MONTH. Was it the first crack in the Building boom? In August, house starts had dropped sharply. The month's total of 83,000 starts was well under the July figure of 94,000 and less than the 86,300 house starts in August last year. The drop was enough to raise a nervous question among Building men, painfully familiar with the boom-and-bust cycle that has characterized their industry in the past, not yet able to believe in the long-hoped-for heaven of a sustained high level of production. But, measured against the normal yearly pattern, the drop was not enough to be taken as the beginning of the sharp contraction that Building—and the rest of the nation—fears. Normally, housebuilding reaches its peak in the spring, drops gently in the late summer to a mid-winter low. Last year, new credit aids, lifting of controls, easing of material shortages had combined to distort this pattern. Now, with the most acute market pressure relieved, housebuilding seemed to be leveling off in its characteristic seasonal way. Moreover, August had been a low pressure area between the brisk trade winds of the old and new FHA programs. The accumulated backlog of applications under the old Title VI (builders had fortified themselves against its expiration) had finally thinned out in July; the new FHA provisions had not been voted.

Last month, as the new FHA program brought in hundreds of applications covering much-needed rental projects, there were few who believed that housebuilding was headed for real trouble. But some additional leveling was almost certainly ahead—this was clear in the tightening of mortgage money.

William Husband, Federal Savings & Loan Insurance Corp. manager, said that the national average for mortgage loans made by insured savings and loan associations is now down to 57 per cent of house sales price. While loan percentages fell, interest rates rose. The 4 and 4½ per cent rates of a year ago had become 5 and 6 per cent. But the tightening of credit looked less like the beginning of trouble than a prudent protection against trouble. The trend of credit was different enough from what happened last time to be positively cheerful—in 1926 interest rates had dropped, while loan percentages had climbed. Not until housebuilding fell flat on its face had the credit freeze set in.

Everywhere Building men were moving in a variety of ways to improve both the quantity and quality of the nation's housing supply. The Prefabricated Home Manufacturers' Institute reported that erection of the 100,000th prefab house took place somewhere in the U. S. last month. Finally winning its flat roof argument with FHA, Reliance Homes appeared on the market with an \$8,000 steel-and-aluminum house. At its annual meeting, the Producers Council reported great progress in its ambitious program to cut house costs; "industry-engineered" houses were going up all over the U. S.

In New York, a group of civic-minded men joined together to start an \$8 million cooperative apartment development, which will qualify for tax exemption under the state Redevelopment Companies Law. In Los Angeles, Metropolitan Life filed plans for \$38 million worth of building—2,700 apartment units to complete its Parklabrea project—thus boosting the month's building permits in Southern Cali-

fornia to a record peak. Meanwhile, housing consultant Frederick H. Allen advised the American Life Convention to try to recover from the fright it had taken at big housing projects by undertaking some small ones. "Fifty units make an efficient rental development," he said.

The U. S. Chamber of Commerce called businessmen to Detroit for a conference on urban problems: all agreed that for action on redevelopment, leadership must come from the men who have the biggest economic stake in urban health. The Spelman fund put up \$100,000 for a 30-month urban redevelopment study, to be directed by veteran houser Coleman Woodbury.

While progress and plans for progress were everywhere evident, this was still not enough to satisfy many. The Veterans of Foreign Wars, at their St. Louis convention, asked for passage of the public housing and slum clearance provisions of the T-E-W bill. Senator Ralph Flanders (Rep., Vt.) was planning to introduce a bill to this end and was consulting with Governor Dewey on its terms.

Economists continued to be cheerful in gauging the Building outlook. With \$11.2 billion worth of new construction already in place, 1948 looked like an \$18 billion year. Top government estimators said 1949 would probably be even better. Long delayed public building—especially schools and hospitals—was going ahead in enormous volume. Airport construction would be speeded by \$40 million in federal aid. The Associated General Contractors, meeting in Chicago, predicted a pick-up in plant building next year, when they think it will be clear to plant owners that building costs are not coming down. If housebuilding seemed bound to slacken a little from its frantic 1947 pace, newcomers were appearing rapidly in the market—the draft was raising the marriage rate.

WASHINGTON

RENTAL BUILDING SPURTS

But many still wait to hear what FHA thinks is a moderate-income rent.

As promised, the new housing law seemed to be a powerful shot-in-the-arm for languishing rental housebuilding. Local FHA offices were swamped with applications for mortgage insurance under the revived Sec.

608 program. FHA cheerfully calculated that the new 608 terms would generate \$1 billion worth of rental housing.

Arguing that the higher-priced apartment market had been exhausted, FHA negotiators were giving preference to 608 projects to rent for \$70 or less a month. This meant that builders could not afford to spend much more than \$7,000 per family unit, so they, in turn, were focusing on small efficiency apartments.

FHA's new program to start \$6,000 and \$7,000 housebuilding was not so fast starting. In many cities housebuilders were meeting with FHA underwriters in an attempt to shave such requirements as storage space, kitchen equipment, etc., a little. Small easements, like this, they said, could go far to produce a \$6,300 house.

There was still a big question about the new yield insurance (Title VII) program. The law had said that yield insurance was to cover equity investments in projects where FHA approves rent for "moderate income" families. FHA had not yet let anybody know what it considers a "moderate income" rent. There was some talk of a flat national rent ceiling. Building sponsors argued that a rent ceiling set for the whole U. S. would likely put yield insurance on the shelf in New York, Chicago, other big cities. A Bronx builder, for example, had already prepared an application for yield insurance to cover a 1,050-unit apartment project, where rents would range from \$59.50 to \$112 a month. In New York, he said, a "moderate income" ranges from \$6,000 to \$10,000 a year.

REMODELING LOAN CURB

New rules boom "package" mortgage

While it still blinked at any big steps to curb inflationary credit, the Federal Reserve Board seemed to be neglecting no small one. It was considering extending Regulation W installment credit restrictions to home repair and remodeling loans. Insiders doubted that the new move would go so far as the one-third down payment

required on automobiles or the one-fifth required on household appliances. The Board will probably put all home repair loans on a par with those made under FHA Title I insurance, which call for 10 per cent down.

Regulation W's requirement that buyers put 20 per cent down on refrigerators, washers, stoves, etc., had already increased interest in the "packaged" mortgage. By including such appliances in a long-term mortgage, buyers can get easier terms.

VETERANS ARE A GOOD RISK

But VA worries about what's ahead

So far, the Veterans Administration has found veteran home buyers a good risk. Of the 1,292,335 home loans made under VA guarantees, only 2,500 borrowers have defaulted. But VA has been anxiously watching the economic weather. While most still think that a depression is only a dim smudge on the far horizon, VA knows that if one breaks it would be in for trouble of hurricane proportions. It would probably have to pay off lenders, take over houses—thus becoming the world's biggest landlord. Just to keep things as weathertight as possible, VA last month decided to withhold pension checks to veterans who stop payments on their home loans without a real hardship reason.

PREFABRICATION

NEWCOMERS

Reliance steel house looks important

The new government credit aids (see above) had already launched two new factory-house ventures.

► Reliance Homes, Lester, Pa., was the first to qualify under the new legislation for an RFC loan, borrowed \$375,000. It was also likely to get the first private production loan approved for FHA-insurance under the new Sec. 609 terms, having resubmitted an application for a \$1 million dollar loan filed under the old program.

Jack Snyder



RELIANCE HOUSE arrives at site in seven completely factory-assembled units. Heating, plumbing and wiring are factory installed. House clips together in two hours. Floor and roof deck are light steel plates. Exterior walls are ribbed aluminum bonded to fiber board.

Reliance looked like a formidable new entry in the house market. Its aluminum-sheathed steel house had a Class A report from FHA's technical division. It also had approval from both VA and FHA for mortgage insurance. (The local FHA office had finally withdrawn its objections to the modern lines given the steel house by famed architect William Lescaze, see FORUM, March 1948). It had 2,300 tons of steel under the voluntary allocation program. Its three-bedroom house, would sell for under \$9,000, including land. For an initial project of 600 houses near Philadelphia, the Peoples Bond & Mortgage Co. had agreed to buy mortgages, also said it would make construction advances available to the project sponsor within 24 hours after delivery of the house to the site.

► General Industries, Fort Wayne, Ind., erected its first four houses under the new FHA plan for 95 per cent, 30-year mortgages on low-cost houses. These houses are of stressed-skin plywood construction, have two bedrooms. Built on lots valued at \$850, they sold for \$6,300.

BRICK VENEER

RFC may get back what it lost

The biggest loss the government took on the old Wyatt guaranteed market program was the \$1,380,000 worth of houses it was obliged to take over from American Fabricators, Pine Bluff, Ark. Last month five of these plywood houses appeared on a site outside Washington. RFC hoped to sell them for about \$11,000. If buyers snapped them up, RFC might put up a good many more of the 300 houses it had taken over—a prospect anything but pleasing to local housebuilders.

PRICES

FLEXIBLE DEPRECIATION

Industrialists say new tax policy would boost plant building

If U. S. plant building had slowed considerably from its peacetime peak in 1946 (\$1.8 billion), there was at least one big reason. The current cost a producer must pay to build and equip a new plant is far higher than his reserves in depreciation charges.

Depreciation charges, which may be deducted from profits before taxes, are figured on the basis of the cost of a plant divided by its useful life. For example, if a manufacturer spent \$5 million for plant and equipment in 1923 and figured he would need to replace it in 25 years, he has been putting away \$200,000 every year in depreciation charges. Now he has his \$5 million savings. But cost estimates show that a new plant would cost nearer \$8 million. To raise the difference means either borrowing or dipping into earnings. A good many corporations have chosen the latter alternative, and stockholders' dividends have dropped accordingly. Others have simply postponed building plans and suffered the

competitive disadvantage of operating in an obsolete plant.

Last month the lively *Wall Street Journal* brought up a notion industrialists have been eyeing for some time. Why not change tax regulations to permit depreciation charges based on current replacement costs?

Manufacturers have suggested that current replacement cost be determined by a construction cost index furnished by the government. Thus values for depreciation purposes could flexibly follow the trend of construction cost.

Tax policy like this could do plenty to shore up Building's present record market. A new team in Washington may well decide that it makes more sense to make it easier for customers to spend their own money for building than to help them borrow for it.

MATERIAL

STANDARDIZATION

What if we had to specify size of every electric light bulb?

The Producers' Council, assembled in New York for its annual meeting, felt the genial glow of accomplishment. The building industry had put up \$37 billion worth of new construction in three postwar years; great technical progress had been made; "industry-engineered" houses, part of the Council's program of modular coordination, had been built in 36 states; the new Construction Industry Information Committee had produced hundreds of newspaper clippings to show how well it had made the house-short public aware of all these things.

From Carl G. Lans, the new technical director of the National Association of Home Builders, came a brisk reminder that there is still plenty to be done. Standardization of building materials is one of the most direct ways to cut building costs. Much progress in this direction has been made. But there is need for much more.

Said Lans: "Imagine if in buying an electric bulb we had to specify that it has to be one to fit type XD31 General Electric! Yet that is what we have to do in effect when we drill for the hardware for an interior door. There are probably 30 manufacturers who make tubular locks for interior doors. Some of these will fit one type of bore-in. The rest of them have just enough variation to make it impossible to tell the door manufactures to produce doors already drilled for tubular locks. Consequently, during this year of 1948, when our builders are producing more than 1,000,000 homes, it will be necessary for carpenters to get down on their hands and knees with a ruler, bit and chisel and measure, drill and chisel a mortise for the particular tubular lock which is going to go in each door. This operation is repeated approximately 10,000,000 times. If only \$1 per door were saved in the standardization of these locks, it would mean a saving of \$10,000,000 to the home-buying public. . . .

(Continued on page 14)

PARK-AT-YOUR-DESK BUILDING will house both autos and offices

Reni



Washington Builder Morris Cafritz (L.) will begin construction next month of a \$6 million, 10-story "park-at-your-desk" building, first in the U. S. The building, designed by Architect LeRoy L. Werner (r.), will house 450 cars in 135,000 sq. ft. of parking space surrounded by 180,000 sq. ft. of office space. Autos will ascend ramps to parking areas on third through tenth floors.

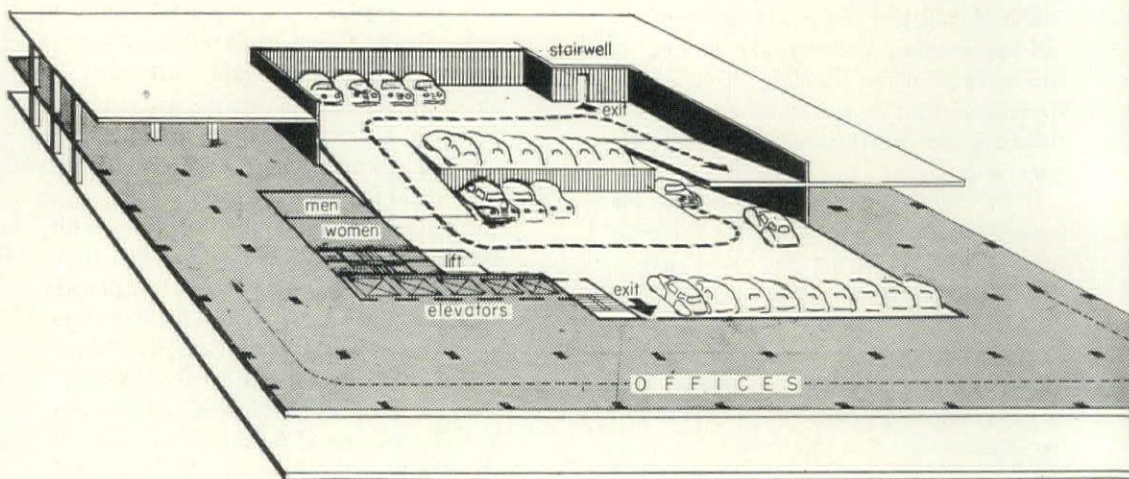

GRUEN SEALS ITS NEW FACTORY from top to bottom with glass

Heat-resistant sandwich glass will seal completely Gruen Watch Co.'s new Cincinnati factory, slated for 1950 occupancy. Building was planned by Woodie Garber, industrial designer; James E. Allan, architect-engineer; Oscar Freidhof, associate architect.

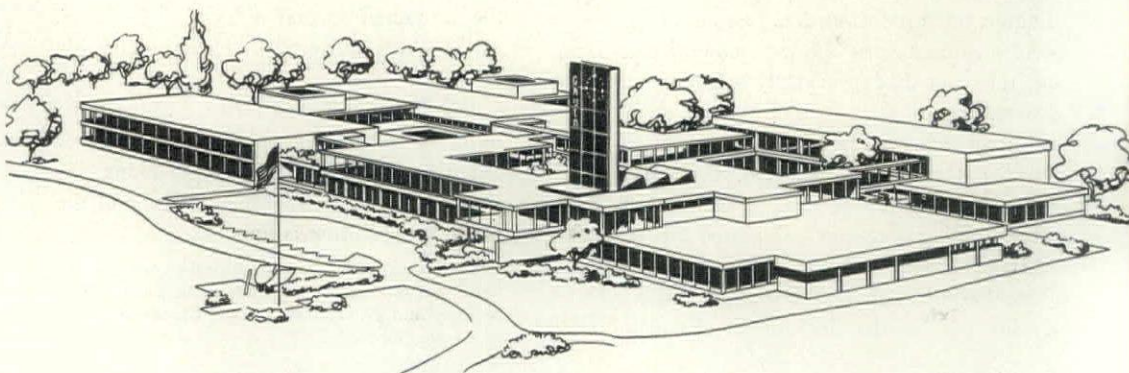
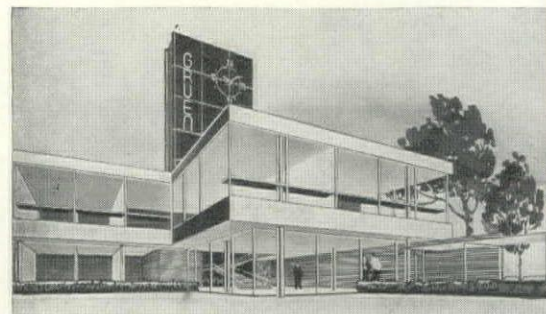

"We need self-furring concrete block. We need concrete block which are self-aligning to speed up laying.

"By standardizing the size of bathrooms, we could use to good advantage, single sheets of wainscot materials, which would not need cutting on the job.

"We need shop fabricated plumbing stacks with standard branches.

"We need more consistent sizes of brick and concrete block.

"Some of these items are now being produced, but we need them in greater quantity. We need items such as pre-fit windows, pre-fit doors, kitchen cabinet units, storage wall units and similar assemblies at prices which will make them adaptable to economy and low-cost construction."

Lans proposed that the Building industry call a Washington meeting, where top experts representing manufacturers, trade associations, government would go to work on a "master plan of standardization."

BASIC CODE

Steelmen think it favors wood

For three years the attempt to draft a basic building code had progressed smoothly. To all appearances, industry was smiling on the attempt of the Building Officials Conference of America to formulate a code that would guide American cities to more efficient building.

Last month, four months before the code's final draft was scheduled for completion, BOCA got its first comeuppance. Steel industry spokesmen let it be known, at a BOCA convention in New York, that they thought the code writers had discriminated against steel in favor of wood.

They objected particularly to the code's recommendation that unit stresses for structural steel be reduced from 20,000 to 18,000 psi, light-gauge steel from 18,000 to 16,000 psi. Said American Iron & Steel Institute's Bert Wood: "The reduction of these unit stresses would not be justified from a standpoint of economy, safety or technical progress in modern construction methods."

Another objection: the proposal to apply to steel the concept of ordinary and controlled materials heretofore applied only to concrete. "... The quality of steel is closely controlled in the laboratory and the mill," said Wood, and the same concept cannot be applied to it that applies to "materials which are processed and partially manufactured on the job."

George E. Strehan, BOCA's code coordinator, charged collusion. Some of the steel manufacturers who were now protesting the code had previously signified approval, he said.

Not so, retorted Steelman Wood. It was only "natural," he submitted, that some manufacturers should change their minds after reading a report circulated by the AISI.

Steel's objection was a snag, but not a serious one, in the drafting of the code.

BOCA made it plain it would go right on with its work.

* * *

Before adjourning its convention, BOCA united with the Pacific Coast Building Officials Conference to form the American Society of Building Officials. Each organization will retain its autonomy and will continue with its own project. (PCBOC is also sponsoring a uniform building code.)

JOBS

UN INVITES BIDS

Two-year building job starts

The future of the United Nations Organization looked more promising from its physical than from its political view. If in Paris the earth was shaking under the organization's structure, at least in New York ground was being moved to prepare for the building of UN's permanent home.

When they finally got Congressional assurance of a \$65 million loan from the U.S., UN planners lost no time. When excavation was begun, they invited bids on construction work from contractors who met qualifications set up by a UN contract committee.* Construction of the 39-story Secretariat building would start immediately after selection of the contractors, probably in late November. Work on the General Assembly and Conference buildings would follow in the spring.

Architect Max Abramovitz (who with Design Chief Wallace Harrison has been supervising preparation of detailed plans) said the plans sent out for bidding contained no technical innovations, but "made use of the best that has been developed." The Secretariat's north-south orientation had dictated use of heat resistant glass in the window wall of the west facade. Early talk of exterior sun blinds had been dropped; windows would probably be the conventional double-hung type, have interior blinds. Air conditioning zones will adapt the cooling system to the varying loads of the wide (east and west) sides of the building.

Bound to tight economy by the size of the loan, the designers had been forced to shave their plans. They had cut the Secretariat from 45 to 39 stories, eliminated lounges, lobbies, exhibition halls, dropped two levels from the conference and General Assembly areas. They had decided not to demolish the square N. Y. Housing Authority building at the 42nd Street entrance, but to use it for a library. Construction of the projected special delegation building, at the north end of the site, is indefinitely deferred.

UN planners looked forward to two hard building years before the transformation of the old slaughterhouse section along the East River into the permanent home of the world organization is finished.

* Advised by Madison Square Garden's John Reed Kilpatrick, N. Y. Life Insurance's Otto Nelson, and N. Y. Triborough Bridge Authority's George Spargo.

PAN-AMERICA

HOMES FOR CUBA

Sugar pays for first large-scale, modern housing development

Havana tobacco tradesmen, *guajiros* from dirt-floored cottages, *guayabera*-clothed sugar farmers gathered daily in Luyano, on the outskirts of Havana, to see the giant machines at work. Even the old men left their domino playing in the city's streets to come and stare. They saw the bulldozers level land and the construction crews pour the massive concrete walls of a handsome housing development. They were watching the first large-scale, modern housing job ever attempted in Cuba. It was being built by the Cuban government, out of sugar profits.

No one could say for sure just when it would be finished, but that was part of the erratic Cuban story. The project had started last year with a magnificent flourish; the first enthusiasm had sputtered a little as the work wore on, and now laborers were slowly grinding away at the finishing stages. But when it was completed—some time next year, presumably—it would house 1,470 Cuban families. Occupants would buy ownership of the 240 units in its eight apartment buildings and of the 1,500 single-family houses at an estimated \$15 a month. There would be a home for the *ancianos*, a nursery, a modern market, two parks, a playground, and a large school.

Cuba's housing need was enormous. Just how enormous no one knew for sure, for housing statistics were all tangled up in recent muddled Cuban history. They were part of the deep postwar inflections in the island's sugar-sweet economy; they were imbedded in the magnificent snarl of its political upheavals. But over half of Cuba's 4½ millions still lived in palm-thatched cottages while even prosperous city dwellers were jammed into tiny apartments cut out of crumbling Spanish mansions. Wartime lack of building materials had compounded the decades-old housing shortage. By war's end, Cubans had all the main elements of their big neighbor's housing crisis—swollen population, inflated national income, scanty and substandard housing—but in a vastly exaggerated form.

Caught in the tide of economic nationalism sweeping Latin America, and excited by the results of the first free election in their history, Cubans were ready to start all kinds of building. They had just elected a government committed to broad development of the country. Moreover, sugar exports had put more pesos in the government's till than had ever been there before.

Bitter labor disputes, hurricanes, and threats of revolution shook the island violently. In their wake, inflation spiraled. But through it all, new president Ramon Grau San Martin stubbornly pushed his development program. Industrialization became a matter of national policy. Great

(Continued on page 16)

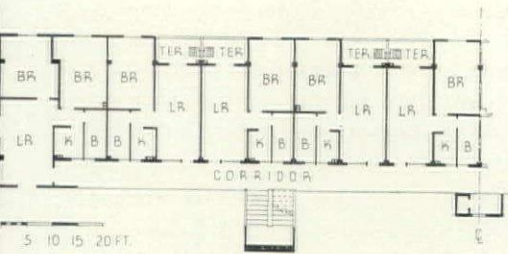

CUBA'S FIRST BIG HOUSING JOB is built in reinforced concrete, with concrete slab roof and marble flooring. Carpentry is Cuban hardwood. Kitchens are equipped for charcoal cooking.



EACH APARTMENT BUILDING cost \$155,000, has 30 two- and three-room units. Windows have only built-in wood blinds; balmy weather, absence of mosquitoes made glass and screens unnecessary.

OLD PEOPLE'S HOME

NURSERY

EIGHT APARTMENT BUILDINGS

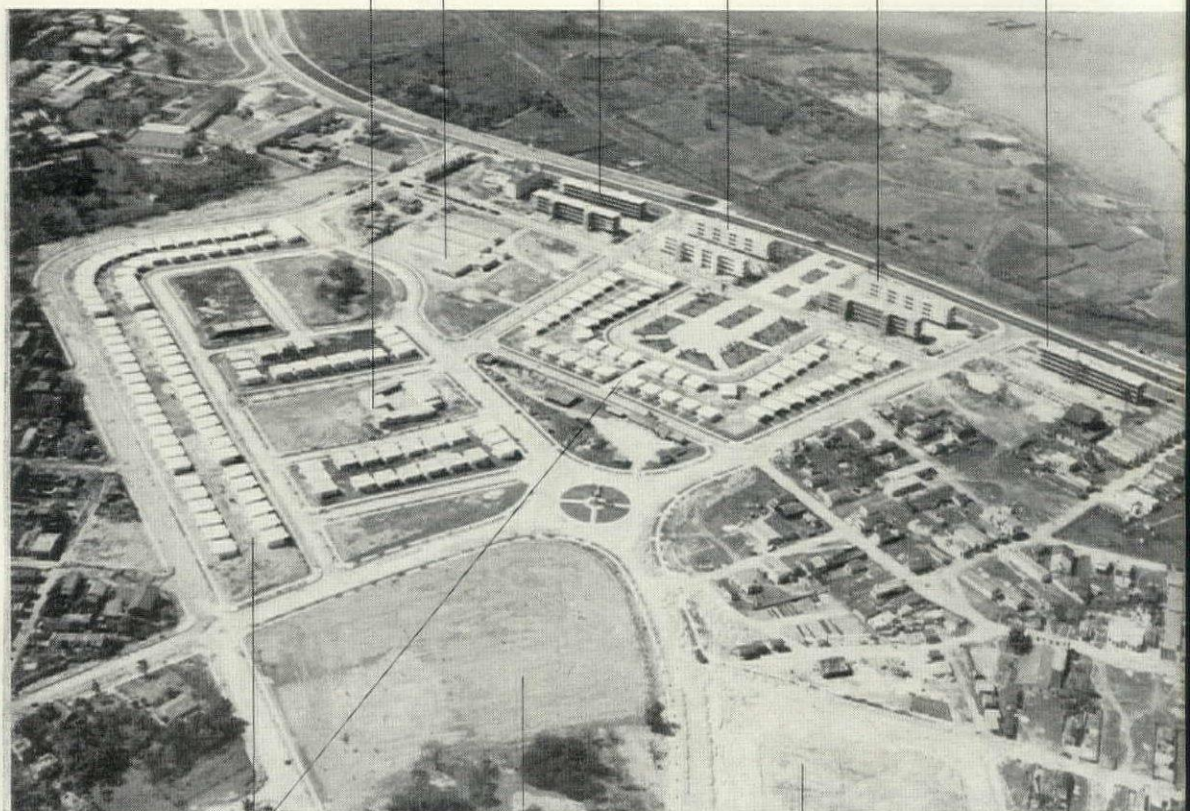

FAMILY DWELLINGS

PLAYGROUND

SHOPPING CENTER

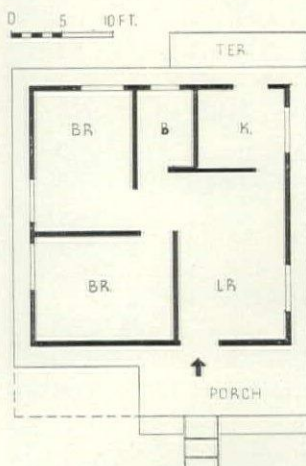
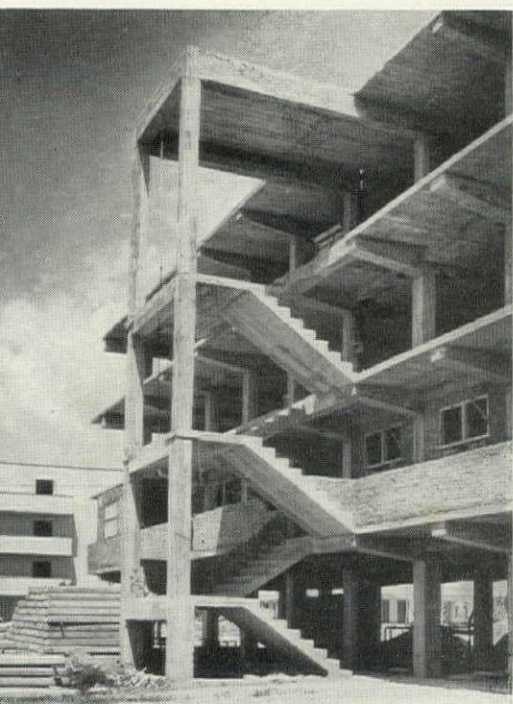

SINGLE-FAMILY HOUSES have four rooms, cost about \$4,000. A backyard with two fruit trees goes with each one. Government may choose tenant-buyers by a raffle among workers.

Photographs by Flores and Albert Radoczy



improvements were necessary which Cuban private capital was neither sufficiently abundant nor venturesome to tackle, so the Cuban government became an active partner in Industry, with enterprises ranging from the installation of hydroelectric plants to the financing of handicraft industries. Parks were developed. Cane fields were artificially irrigated and drained. Broad modern highways began to replace many of the clay-rutted oxcart paths which crisscrossed the island's 750-mile expanse. Some communities saw the first large hospitals and schools in their land-bound history.

Then the swamp land at Luyano was reclaimed and leveled, under Architect Jose San Martin,* Minister of Public Works, and Cuba started its biggest housing job.

If the government was giving the Cuba's housebuilding boom dash by tackling the most ambitious project, private builders were supplying the boom's substance. They were busy everywhere, now that they could get their hands on materials. Large areas of suburban Havana which ten years ago were unpopulated now have many three- and four-story apartment buildings. The construction drive had passed even through colonial "Old Havana," leaving modern apartment buildings on its narrow, old-world streets. Workers' settlements were growing up around recently built branch offices of American industries. The face of the island was slowly changing: a concrete tower was becoming as familiar a sight as a row of royal poincianas.

* Cousin to the president.

DESIGN

USONIA HOMES

Every family has an acre

"In the City of Yesterday ground space was reckoned by the square foot. In the City of Tomorrow ground space will be reckoned by the acre: an acre to the family. On this

basis architecture would come again into the service, not of the landlord, but of the man himself as an organic feature of his own ground. Ground space is the essential basis of the new city of a new life."

Since Frank Lloyd Wright described his vision of a decentralized Broadacre City in 1932, he has made many a hopeful plan. There was, for example, the low-cost scheme for an auto workers' cooperative near Detroit. It was "abandoned for lack of cooperation." There was the Massachusetts housing project designed at the request of the federal government, based on a "cloverleaf" ground subdivision plan. It was never built because local architects objected to the employment of out-of-state talent. (See FORUM, Jan. '48).

Last month bricks and concrete blocks were rising in the first Wright-planned community to move from plan to construction. This was a cooperative development of 50 houses, on 97 rolling, wooded acres in New York's rich Westchester County. Usonia Homes, Inc. will also be the first large community in the East to be built according to the principles of contemporary architecture.

Wright had made the site plan: 55 circular plots of about an acre each. Five of these as well as spaces around the plots would be used for park, playground, other community purposes. Wright was designing five of the houses, all community buildings, and acting as supervising architect. Members of the cooperative could select their architects from an impressive panel (some of them former Wright apprentices): Paul Schweikher, Winston Elting, Alden B. Dow, Marcus Weston, David Henken, Aaron Resnick, Kaneji Damoto, Robert Bishop, John W. Wright, Jr., and Theodore Bower.

Seven families expected to be in their houses (see cut) by snowfall. They would pay from \$10,000 to \$30,000 for them. The

John Ebstel

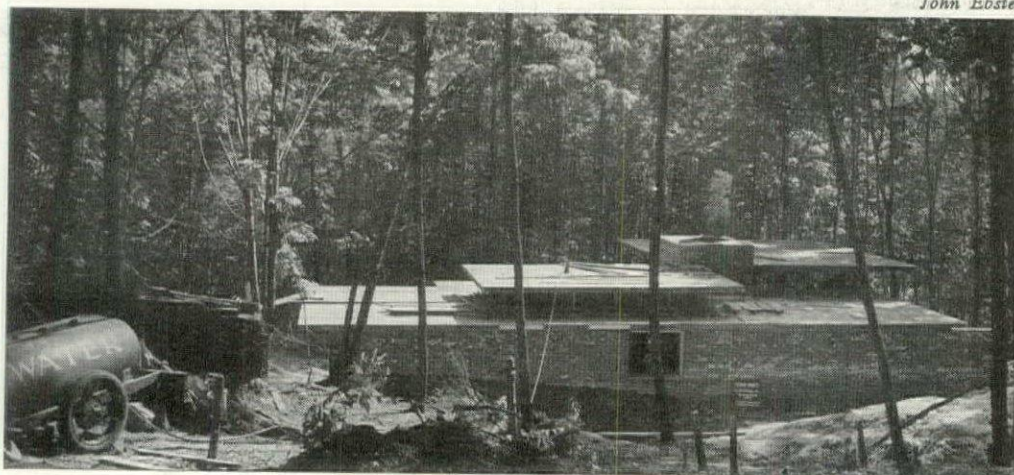

SAMPLE USONIAN HOUSE was designed by David Henken for his parents. Of brick and cypress, with large living-dining area, two bedrooms, raised fireplace, it is expected to cost about \$9,500. It has radiant heating and a concrete mat foundation, which extends as a terrace on two sides. The mat is broken for inside planting directly in the ground.

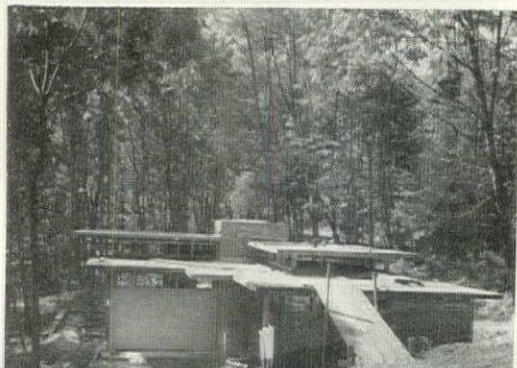

cooperative hoped to start building its nursery school, theater, swimming pool soon. When everything is finished there will be one unit especially pleasing to Frank Lloyd Wright, who lays much of his creative capacity to childhood summers on his uncle's farm: a demonstration farm, where ex-New York children can find out what it is like to milk a cow.

FLEXIBLE SCHOOLS

FSA warns that traditional design may be a billion dollar mistake

Bewildered educators, pinned to their desks by the unprecedented postwar rush into their schools and universities, have been grappling since war's end with the non-educational problem of how to provide for the largest classes in U. S. history. Their resourcefulness has surprised them, and the rest of the nation. Some have revived the classic practice of the Greeks and led their students to the shade of an uncongested tree. Many have adapted devices more associated with destruction than scholarship and conducted their classes in Quonsets and abandoned aircraft sheds. All have performed the strenuous task of jamming 35 or 40 students into a classroom designed for 20.

Everyone knew the situation was bad. A report last month by the Federal Security Agency's Office of Education told just how bad it really is: Virtually no school construction or maintenance has been carried on since the beginning of the war. New courses and methods have rendered many existing facilities obsolete and inadequate. A staggering \$11 billion is the size of the new school buildings needed to set our worn-out educational plant to rights.

Even more important to the future of U. S. education, however, was the concern over the shape of tomorrow's school which grew out of the FSA report. Federal education authorities recognized that, in view of the tremendous social changes that await the nation, traditional school design would be a billion dollar mistake.

For more or less permanent communities, FSA thought that more flexible buildings would be required. As classes grow larger (as they are doing now with the enrollment of the first wave of war babies), such devices as removable partitions and expandable walls can do much to relieve overcrowding.

But in recent years the deterioration of city neighborhoods has left many an elementary school serving only a fraction of the students it was designed to care for. Meanwhile, swelling population at the suburban ring has demanded expensive new building. But if yesterday's pat answer to this kind of population shift had been urban redevelopment, now the big new push toward industrial decentralization (see p. 20) loomed as a highly unpredictable factor. It seemed certain there would be a

(Continued on page 18)

DOUBLE DUTY INSULITE

* (LOK-JOINT LATH)
Inside

* (BILDRITE SHEATHING)
Outside



BUILDS

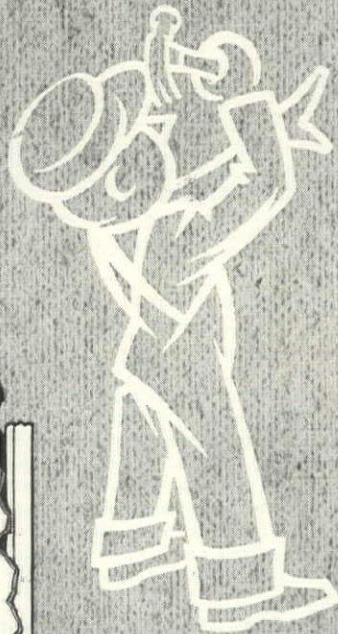

INSULATES

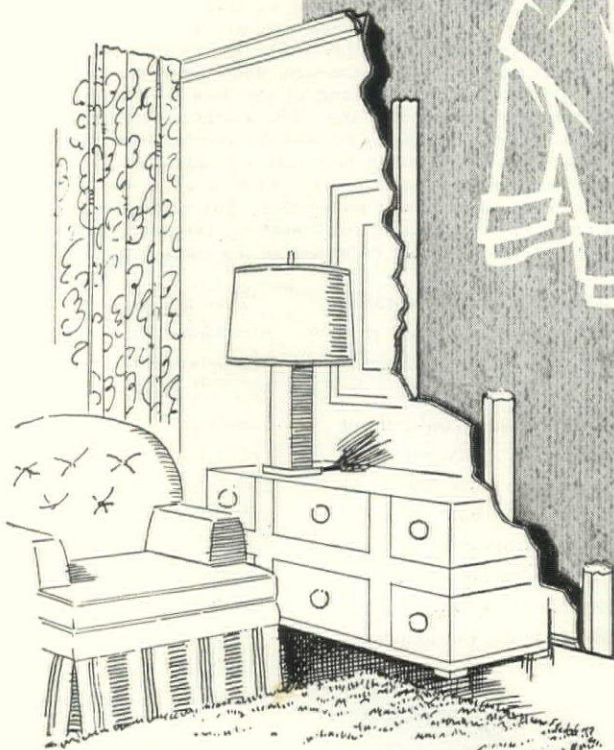
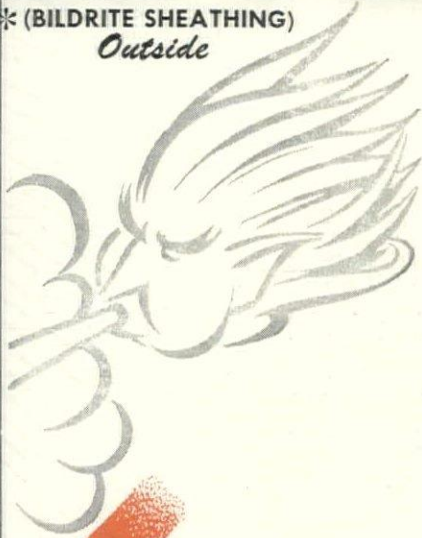

Quality construction brings you more satisfied customers. When you specify double-duty INSULITE—inside and outside you specify top quality construction. It's *stronger*, because Insulite (Bildrite) Sheathing provides twice the bracing strength of wood sheathing horizontally applied. It's *better*, because the combination of Bildrite on the outside plus Sealed Lok-Joint Lath on the inside provides insulation, and guards against moisture condensation.

Refer to Sweet's File,
Architectural Section 10a/9

**INSULATES
AS IT BUILDS**

double-duty
INSULITE

**BUILDS AS IT
INSULATES**

The GENUINE

INSULITE DIVISION
PAPER COMPANY
MINNEAPOLIS 2, MINNESOTA



MINNESOTA & ONTARIO
PAPER COMPANY

"Insulite" is a registered
trade mark, U.S. Pat. Off.

10 LATH

Ben Schnal

NEW
Flexalum
REG. U. S. PAT. OFF.

the
venetian blind
slat material
that meets the
exacting standards
of modern
architecture

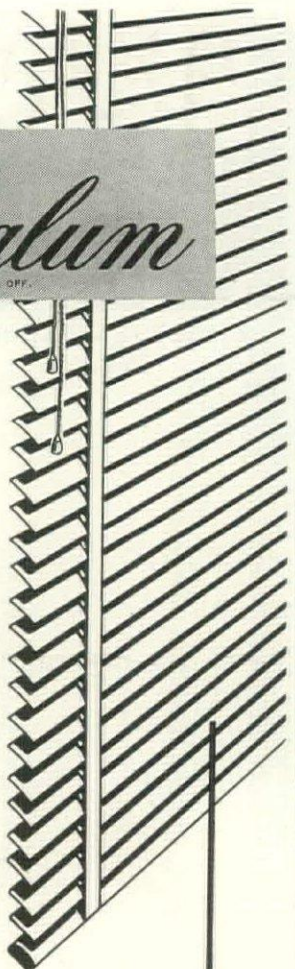

In tests of 7 leading slat materials by The United States Testing Co., Inc., this lightweight aluminum out-performed all others—

MOST FLEXIBLE*—when bent 180 degrees around a 1½" mandrel, only Flexalum snapped back without damage.

STRONGEST* when bent at route holes. Flexalum retained snap-back up to a 90-degree angle. Nearest competitor failed at 70 degrees; others at 50 degrees or less.

PRECISION CONSTRUCTION*. Flexalum is accurately crowned for complete closure, exact control of light and air. Does not warp... takes any normal strain.

CAN COVER LARGE GLASS AREAS in contemporary homes and offices. Flexalum is so lightweight it's easy to raise and lower... and it won't sag. Thus only one blind is required, even on very large areas.

PLASTIC ENAMEL FINISH RESISTS DIRT...does not chip, crack or peel. Sealed on at a temperature of 600 degrees. Flexalum is also rustproof, fire-resistant.

Only reputable venetian blind manufacturers use Flexalum. Identify it by this quality insignia on the slat.

*TEST NO. 92296
APRIL 12, 1948

HUNTER DOUGLAS CORPORATION

150 Broadway, New York—Riverside, California

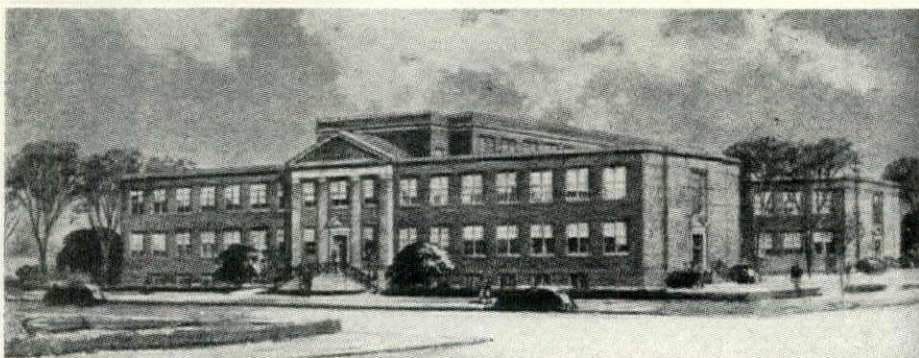
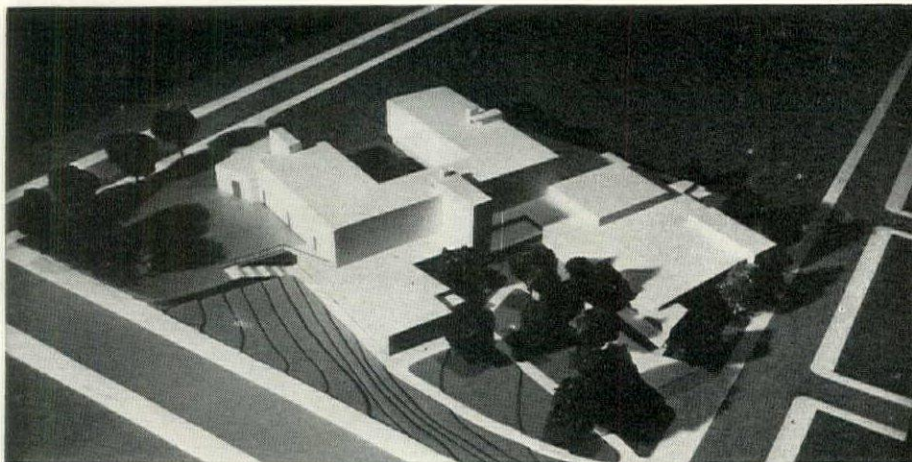

ALTHOUGH FEDERAL EDUCATION EXPERTS had warned school boards that traditional design schools built now may prove to be a billion dollar mistake, New York City's board of education last month cancelled its plans to build the contemporary school shown above in Staten Island. This school was designed (after careful study of the Staten Island site and the space requirements outlined by the board) by William Lescaze, designer of the famed Philadelphia Savin Fund Society Building FORUM, Dec. '32) and of the Ansonia (Conn.) High School (FORUM, Dec. '37), the first contemporary school in the East. Instead the board plans to build a conventional building (below). The Lescaze design was for reinforced concrete, and this shift from the structural steelwork hitherto used in city school buildings seems to have intimidated contractors, for the board got only one bid. On the basis of this bid, the board decided that a sharp reduction of its space requirements was imperative. But instead of asking Lescaze to revise his well-organized plans to the cut-down requirements, the board substituted one of its stock plans. Thus New York City will invest its money in a structure already obsolete.

shift away from the metropolitan population centers, but nobody could say just how big the exodus would be or where it would wind up.

FSA made the best guess it could about all these uncertainties. It advised local school authorities to think more about the long-range pattern of need, about the flexibility offered by contemporary design, about temporary, easily erected school unit construction. Demountable schools that could move as their students move would probably soon be seen.

MARKET

SPREADING OUT

More than The Bomb is making concentrated industry decide to scatter

Ever since the National Security Resources Board warned Industry last July that its only protection from possible atomic bombing was dispersion, Builders with an eye on tomorrow's market have looked more closely at the statistics of decentralization in the U. S.

Through a glass clouded by economic conditions, existing trends, and the vague but persistent threat of nuclear explosion they were able to see distinctly one fact: American industry is indeed spreading out. There had been no mass migration of men and machines westward through the Appalachians and into the wheat country dramatized that fact, but a clear pattern of decentralization existed nonetheless. For six per cent of the 2,038 plants erected since war's end had been built away from established centers, in towns with populations of 50,000 or less.

Would this give substance to NSRB's arresting contention that Industry must scatter in the wake of atomic threat? Builders and economists were inclined to be skeptical. There was some alarm over The Bomb, of course. At least one factory—United Aircraft's Chance-Vought Division—had said that protection from air attack was its main reason for traveling from Connecticut to Texas. Another—Smith Wesson, small arms manufacturers—had

(Continued on page 20)



Whether a Store is Old or New... **PLEXIGLAS** makes it *MODERN!*

The dominant trend in the food world today is towards modern supermarkets—and the modernization of existing chain stores. And PLEXIGLAS makes it easy to make them modern!

Take, for example, the new Food Fair Supermarket in Atlantic City, shown here. Luminous tan by day, glowing green and white by night, the 80' all-PLEXIGLAS sign—largest ever made—contributes to the store's modern appearance. The smaller illustration shows how simply yet effectively the sign is constructed for easy erection and maintenance.

Inside this store—as in hundreds of others—PLEXIGLAS fixtures simplify shopping—track signs, trays, display cases, produce bins, partitions, racks and lighting shields. Easy to install, too, because PLEXIGLAS is light, shatter-resistant, easy to form and machine.

Interested in store design or modernization? Then send for full information on planning with PLEXIGLAS. It's yours for the asking—without obligation.

PLEXIGLAS is a trade-mark, Reg. U. S. Pat. Off. PLEXIGLAS acrylic resin sheets, rods, and molding powders are manufactured only by Rohm & Haas.

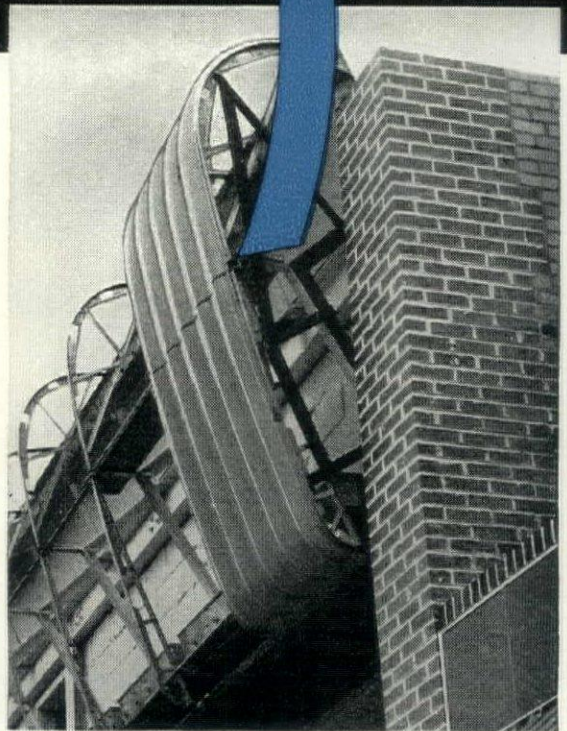

For this 80' x 11' sign Food Fair store architects chose PLEXIGLAS, the lightweight outdoor plastic that resists weathering. Formed of curved translucent Tan #532, 1/8" thick. Letters cut from yard-square transparent Red #160, 3/4" thick. Neon tube behind each corrugation gives high luminosity. Erected by Hutchinson Sign Co., Trenton, N. J.

ROHM & HAAS COMPANY

WASHINGTON SQUARE, PHILADELPHIA 5, PENNSYLVANIA

Manufacturers of Chemicals including Plastics • Synthetic Insecticides • Fungicides • Enzymes • Detergents • Germicides
 Chemicals for the Leather, Textile, Ceramic, Rubber, Paper, Petroleum and other Industries



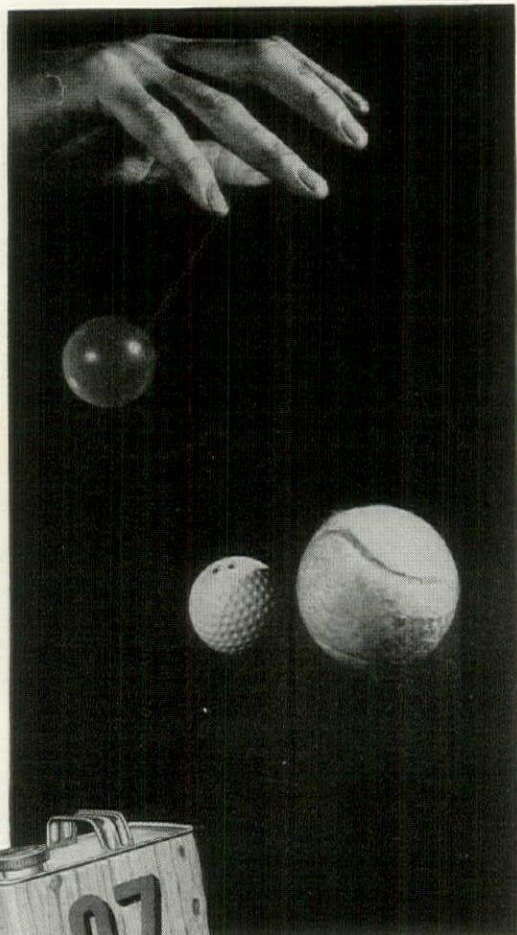

Dries in 4 hours



DEVOE 87 SPAR VARNISH HAS DEMONSTRABLE SUPERIORITY

STROBOSCOPIC photo shows that a ball made of Devran*, the new Devoe synthetic resin used in 87 Spar Varnish, bounces higher than either a golf or tennis ball.

"Bounce" is simply a short way of expressing the resilience and toughness which give Devoe 87 Spar such notable resistance to physical damage. Equally demonstrable, both in the laboratory and in actual use is its exceptional resistance to damage from liquids including alcohol and hot cleansing solutions.

Specify Devoe 87 Spar wherever a superbly durable and beautiful finish is called for—on floors, woodwork, furniture and boats.



*Patent Applied for

ANOTHER DEVOE PRODUCT

Distributed by
 Peaslee-Gaulbert Paint & Varnish Company
 Truscon Laboratories
 Wadsworth, Howland & Company
 Devoe & Reynolds Company, Inc.
 787 First Avenue, New York 17, N. Y.

actually dug underground for atomic-age insurance. (FORUM, Aug. '48).

But for the most part, Industry's spokesmen seemed to think there were other, more important causes for the postwar speedup of the decade-old trend toward decentralization. Most significant of these causes: the new conviction that industrial concentration is inefficient.

American Industry had completely discarded its fetish of bigness. Industrial leaders, suffering for years from top-heavy plant control in highly concentrated areas, had swung to a belief in the economic rewards of maintaining smaller plant units in smaller communities.

Spokesmen saw other factors behind the relocation drive:

► Shift in population. The war had given new impetus to the gradual, long-time shift westward of the population. No one was able to say for sure just where the center is now, but the 1940 census had located it 50 miles south of Terre Haute, Ind.

► Breaking up of the basing point system. Steel's return to the f.o.b. pricing system—and the probable return of business generally—as a result of recent supreme court decisions would probably prompt industrial movement.

► Changes in the freight rate structure. The established structure had tended to freeze the advantages of industrial location in the north-eastern U. S. Continued and successful government attempts to change that structure would aid significantly in the industrial development of other sections.

► Power supply. The southwest had attracted many a new industry with its offer of cheap, abundant supplies of natural gas, as have areas provided with cheap electric power by government projects—Bonneville, TVA, Grand Coulee, Boulder Dam.

► New sources of labor. Government experts generally pooh-pooh the idea that Industry is still looking for areas free of organized labor strength. But industrial searching for lower labor costs in smaller towns was nonetheless contributing its bit to plant relocation.

The push toward decentralization was strong enough to alarm the Pennsylvania Railroad, which recently set up a new department to advise with industry on dispersion. Pennsylvania hopes, not to stem the decentralization tide, but at least to channel it along Pennsylvania's present 11,000-mile main trackage.

Industry seeking advice on relocation could also go directly to NSRB, which last month appointed Gayle W. Arnold, railroad executive, to head its plant dispersion division. Arnold was wartime consultant to

(Continued on page 22)

Mars Lumograph is the Only pencil

That Combines These 8 Tests of Pencil Superiority

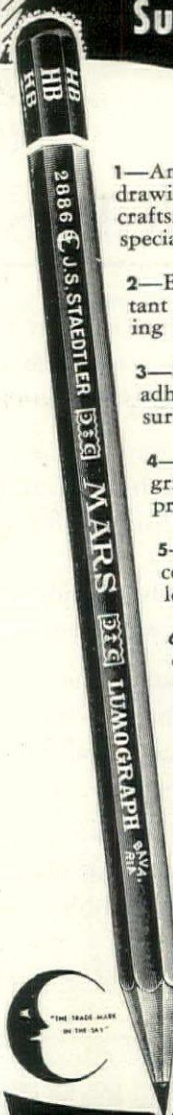

1—America's ONLY imported drawing pencil—made by craftsmen with generations of specialized experience.

2—Extra-dense lead of resistant opaqueness—approaching blackness of India ink.

3—Smudge-resistant graphite adheres closely to tracing surface.

4—Completely free from grit and foreign matter present in most leads.

5—Precise standards insure constant uniformity of lead hardness.

6—Insures perfect reproductions direct from the pencil drawing—no extra steps.

7—Degrees marked on all 6 sides for instant recognition.

8—Finest Southern cedar sharpens easily and grips lead securely. Polished blue, black-tipped and stamped in gold.

Try Mars-Lumograph. Compare results. At your dealer's. Write direct for nearest supplier, or order sample dozen direct from Dept. A for \$1.50.

J. S. STAEDTLER, INC.
 53-55 WORTH STREET
 NEW YORK 13, N. Y.

LEVOLOR

Reg. Trade Mark of Lorentzen Hardware Mfg. Corp.



Hotel New Yorker
Architects: Sugarman and Berger

SPECIFIED HERE



"...eliminates 78% of the calls for Venetian Blind service"

says Frank L. Andrews, President,
Hotel New Yorker

Specifying important improvements like LEVOLOR-fitted blinds is the big, basic reason behind the success stories of America's outstanding hotel managers. LEVOLOR self-adjusting tilters eliminate many service calls because LEVOLOR keeps cords from climbing to the top of the blind. Thus, LEVOLOR lowers room maintenance costs, adds to the comfort of guests . . . builds good will. For LEVOLOR is the outstanding advance in Venetian blind hardware that makes blinds WORK as well as they LOOK for the life of the blind.

Reputations are established by the apparently small, specified things that make the BIG DIFFERENCE IN PERFORMANCE . . . that eliminate complaint factors, accident factors . . . that cut service costs. LEVOLOR is the registered trade mark for self-adjusting tilters made by Lorentzen Hardware Mfg. Corp., New York 12, New York and built into Venetian blinds by hundreds of reputable manufacturers. Write Lorentzen for a list of manufacturers in your area who are qualified to supply LEVOLOR-fitted blinds.

"Tilt gear to automatically keep cords level, shall be LEVOLOR as manufactured by the Lorentzen Hardware Mfg. Corp. or approved equal." Quoted from specifications of American Hotel Association.



LEVOLOR is a rare achievement in Venetian Blind Hardware. It combines the sturdiest wrought steel for long, dependable service plus contrasting metals where needed to eliminate "freezing" . . . "sticking" and "jamming".

LORENTZEN HARDWARE MFG. CORP., 391 W. BROADWAY, NEW YORK 12, N. Y.

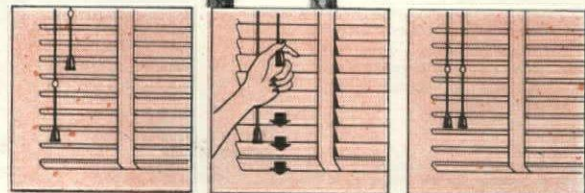

When tilt-cords "creep" . . . just PULL the short cord . . . and "CLICK!" they come back even

HOW TO PROVIDE

Maximum Heating Comfort

in homes heated by forced warm air

Specify

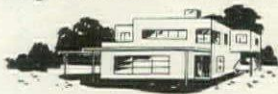

DOLE

Thermostatic AIR CONTROLS



Individual room temperature automatically

The Dole Thermostatic Air Control System—the greatest advance in home heating since automatic firing—materially improves any forced warm air installation. It stops overheating of individual rooms—diverts heat to the rooms that need it—saves fuel. Automatically, Dole Thermostatic Air Controls compensate for effects of wind and sun. Simplified—easy to install—positive in results—assures uniform heating for the entire house.

- Very sensitive, Dole Thermostatic Air Controls give a modulating effect.
- Completely self-contained—no fire to run—no bulbs to locate.
- Assures that heat output balances heat losses—with zone control for every room.
- Easy to install, corrects many unsatisfactory heating conditions.

Write for complete information now!
See the new Sweets Catalog!

THE DOLE VALVE COMPANY
1933K Carroll Ave., Chicago 12, Ill.
Representatives in Principal Cities

CONTROL WITH DOLE

the Army's Chief of Ordnance on plant location.

If they took NSRB's advice, plant owners seeking new locations would be obliged to stay as far as possible from each other. Industry, NSRB had said, would accomplish nothing if it moved away from the



ARNOLD

crowded Atlantic seaboard only to form new industrial centers in the rapidly growing south and west. There was no safe place. The only thing to do was to spread out as thin as possible. This meant location in areas where neither a labor supply nor housing facilities would be available. Many industries were already finding it necessary to build housing for their employees. Alcoa, for example, had asked housebuilder James F. Byrne to undertake 100 houses for workers at its new plant in Davenport, Iowa. Last month the Meredith Publishing Co. in Des Moines bought 100 acres, announced a \$2,500,000 housing development with shopping center for its employees. Government housing officials reported many inquiries from industries planning new locations who think that the new factory-built houses now coming on the market may be the best answer to their needs. The trend toward industry-sponsored housing seemed bound to increase, and every alert housebuilder was reckoning with this important new factor in the Building Market.

Industrial settlements of 50,000 persons or less is the maximum size that NSRB would like to see U. S. cities have. Obviously the new town should spread out on the horizon, not pile up vertically.

If there was no immediate prospect that giant U. S. urban complexes would break down into towns of 50,000, there was enough of a movement in this direction to raise grave questions about long-hoped-for urban redevelopment. Why invest billions in rebuilding blighted city neighborhoods—if city dwellers ought to move away? Planners were beginning to think about planting cleared slum areas to grass seed instead.

OVERSEAS

REHOUSING

Europe will want plumbing equipment and lumber, skilled building bosses

Europe was no longer hungry. That was Step No. 1. Ruined factories were being rebuilt and the wheels of gutted industries

(Continued on page 24)

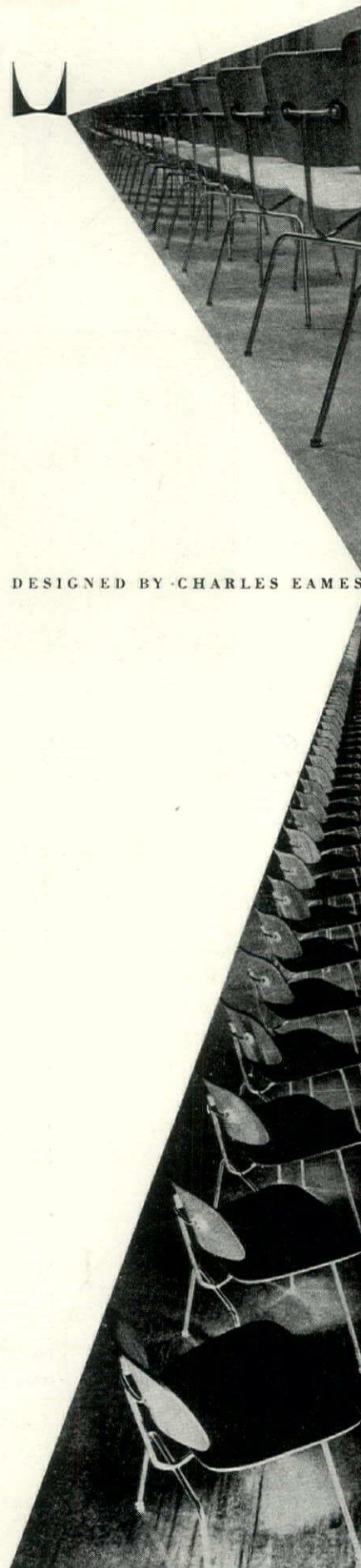

DESIGNED BY CHARLES EAMES

PRODUCED BY EVANS PRODUCT CO.
SOLD BY HERMAN MILLER, ZEELAND, MICH.



Do your floors look like this—
AFTER TWELVE YEARS?

THE photograph above shows you how the Wingfoot rubber floor installed in one of New York's largest and busiest automobile salons twelve years ago looks today. After being walked upon by more than *ten million* people it still retains an unblemished, high-shine appearance, as you can see.

Such service is typical of this high-quality flooring under heaviest service conditions. That's why you can specify it with confidence for public buildings, stores, offices and homes where beauty and durability are essential.

Wide choice of colors

Wingfoot rubber flooring is made by Goodyear in fourteen attractive multi-tone and plain colors that harmonize with

any decorative scheme. It comes in both sheet and tile, enabling you to plan floors in many designs and color patterns.

Wingfoot colors will not walk off under heavy traffic, nor wash off when cleaned with commercial compounds — the color goes through from top to bottom. It is resistant to fire, alcohol, ink and stains. A damp mop cleans it.

That is why so many architects specify Wingfoot Flooring for their "showcase" jobs. They know it retains its looks for many years — a silent testimonial to their good judgment.

For complete specifications, see Sweet's Catalog, or write Goodyear, Builders Supply & Flooring Dept., Akron 16, Ohio.



WINGFOOT *Rubber* **FLOORING** { SHEET and TILE }
 by
GOODYEAR

Wingfoot—T.M. The Goodyear Tire & Rubber Company

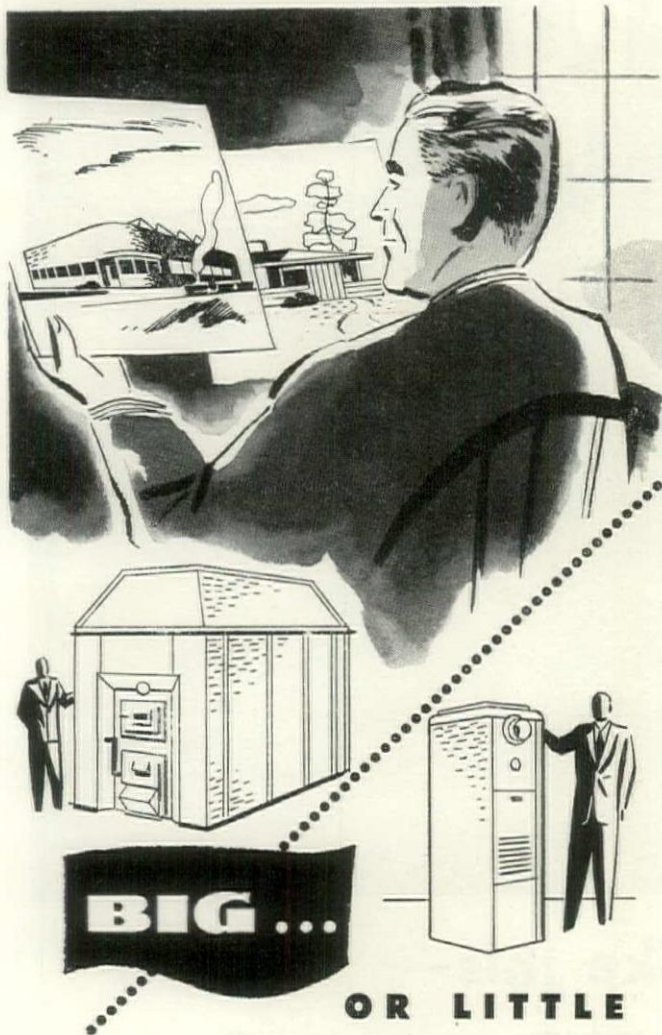

BIG ...

OR LITTLE

WEIR-MEYER HEAT

IS THE *Smart* CHOICE

Modern WEIR-MEYER units offer outputs from 50,000 BTU/hr to several million BTU/hr. You can select the right equipment for any job, for any fuel. Because it's WEIR-MEYER, you can take efficiency and dependability for granted. Specifying all heating equipment from one reliable manufacturer simplifies estimates and specifications — lowers costs, too, and makes installation easier. Write for descriptive literature and specifications. WEIR-MEYER means Modern heat!



THE MEYER FURNACE COMPANY

Weir-Meyer Furnaces and Air Conditioners for . . .
GAS, OIL, COAL

Offices: Peoria 2, Ill. Factories: Peoria and Peru, Ill.

were starting to turn once more. That was Step No. 2. Now the Economic Cooperation Administration was getting ready to start Step No. 3 of the job in Europe: rehousing.

Last month ECA boss Paul Hoffman named Mathias Niewenhouse head of the Forest Products and Building Materials Branch. Like the other men Hoffman had



NIEWENHOUSE

Reni gathered around him, Niewenhouse was no government careerist. As the head of a New York contracting firm, he had spent 25 years building factories, apartments, business structures. When war came, he went to work for WPB, in the tough job of deputy director of the lumber division. Now he would have to decide how much building materials the U. S. can spare for Europe's great need.

The cooperating European nations were surveying the size and character of their rehousing job. Soon they would hand ECA a bill of materials. This would show how much their own revived industries can supply, how much they would need from the U. S. Without these facts, Niewenhouse sensibly refuses to speculate on how much building materials exports will need to be stepped up. Some materials, he reminds, are already being produced in excess of record domestic requirements — flooring, for example. He emphasizes the injunction Congress made when it created ECA: our commitments abroad must be measured against our requirements at home. He makes it clear that he will not back rebuilding Europe at the expense of our own building needs.

Europe, as it always has, will want two main items: plumbing equipment and lumber. But these are the tightest spots in U. S. building supply. Export crackdown had already turned up brisk illicit traffic in plumbing fixtures. Last month the Commerce Department seized 600 crates at the docks. An export declaration had listed the goods as cast iron toilet bowls. These are little used in the U. S. and not under export control. But Commerce inspectors noted that more cast iron toilets seemed to be crated for shipment than were produced last year. Opening the crates, they found vitreous china bowls, a closely controlled export item.

But even more than plumbing and lumber, some government men say, Europe needs skilled U. S. Building men. Technical brains—architects and engineers—they have aplenty, but they lack building bosses who know how to organize the giant jobs which are all in a day's work in the U. S.



When you specify the new EAGLE Door Closer you don't have to worry about the correct hand for any installation. It automatically adjusts itself to the proper hand when installed. Here's why:

Unlike other closers, this advanced-type EAGLE unit uses all available space for mechanical performance. Two pistons work in two cylinders with two springs to give twice the efficiency of liquid displacement, through simple one-screw regulation. The field control is automatically regulated by "V" slots correctly machined in the cylinder walls. Thus, the regulating screw controls only the latch speed. Furthermore, with the EAGLE closer it's easy to obtain the hold-open or non-hold-open feature through proper installation.

You'll do better specifying this light-weight and more compact EAGLE unit, with its 4-in-1 versatility.



The EAGLE LOCK Company

Eagle Industries, Inc.

National Sales Representative

110 North Franklin St., Chicago 6, Illinois

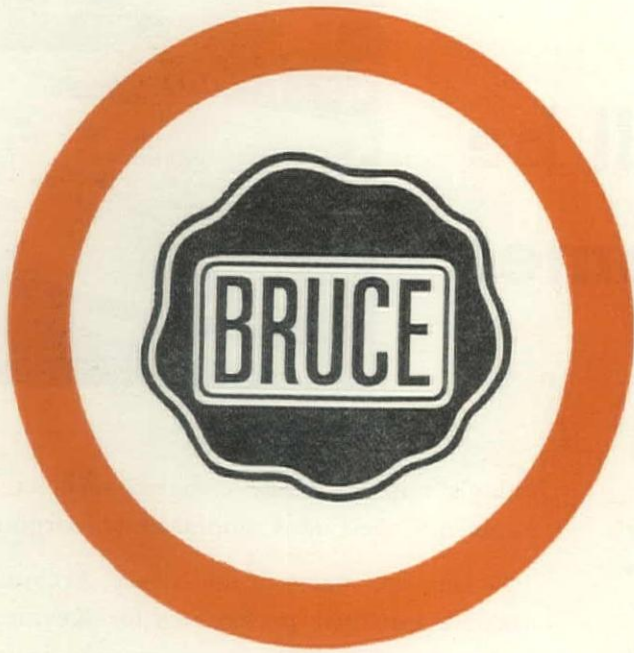

A trade-mark
you can **DEPEND ON**

**For Finer
Hardwood Floors**

Now that the days of buying "whatever is available" are drawing to a close, people are once again turning to trade-marks they can depend on. In hardwood flooring the popular trade-mark today, just as it has been for more than a quarter of a century, is the familiar Bruce seal. Backed by a world of experience and knowledge in flooring and floor finishing, this is one of the best known trade-marks in the building industry. Owners, architects, builders, and lumber dealers all know they can depend on it for floors of quality, style, and beauty.

E. L. BRUCE CO., MEMPHIS 1, TENN., *World's Largest in Hardwood Floors.*

Bruce Hardwood Floors



Prefinished and Unfinished

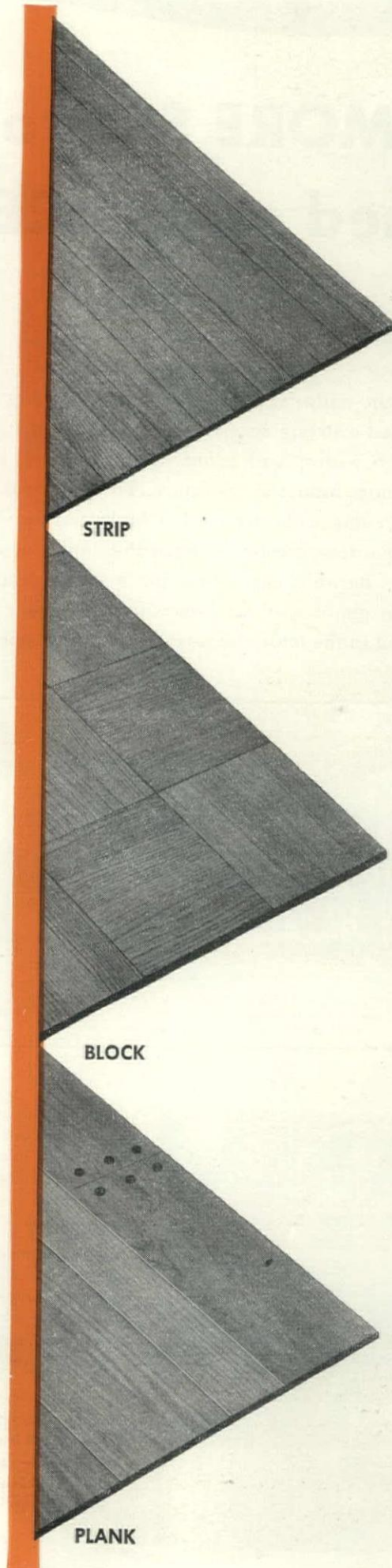

STRIP

BLOCK

PLANK

Architects Interviewed from Coast to Coast Agree

-MORE Stucco will be used on MORE homes



A recent national survey conducted among Architects revealed a strong acceptance of reinforced stucco siding—and a widespread belief that stucco will be used on even more homes in the future. The principal reason for the acceptance of stucco is that Architects consider stucco, in its modern, steel-reinforced Portland Cement form, a strong, durable, easy-to-maintain siding material. And, a great majority of Architects feel that more stucco will be used in the future because it is highly appropriate for

today's popular home designs, such as Ranch-Type, Modern, Cape Cod, Colonial and Georgian.

During the course of the survey, Architects were also asked about their preferences for Keymesh steel reinforcing for stucco. The Architects who prefer it above all other types do so because they like its open mesh design, insuring deep embedment of each steel wire in the "scratch" coat. They like the fact that Keymesh is galvanized for lasting rust-resistance, and believe that Keymesh gives a better "key", a better bond and stronger reinforcement.

When you specify Keymesh reinforcing—either for a new home or a remodeling job—you are assured of strong, durable stucco with permanent crack-resistance, and stucco that retains its beauty. Write for your copy of the new, interesting booklet "Specifications for Beautiful, Durable Stucco and Overcoating Reinforced with Keymesh". Keystone Steel & Wire Company, Peoria 7, Illinois.

Keymesh is shipped in rolls 150' long by 3' wide. For stucco and overcoating, specify Keymesh 1 1/2" hexagon mesh, 17-gauge galvanized steel wire, or 1" hexagon mesh, 18-gauge.

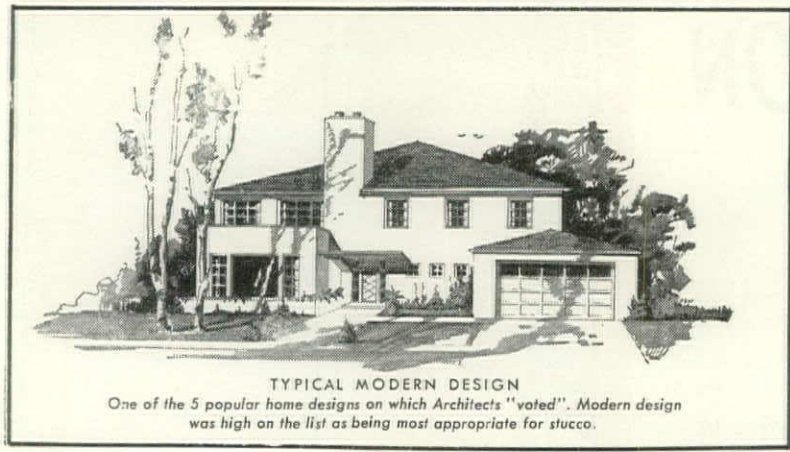

TYPICAL MODERN DESIGN
One of the 5 popular home designs on which Architects "voted". Modern design was high on the list as being most appropriate for stucco.

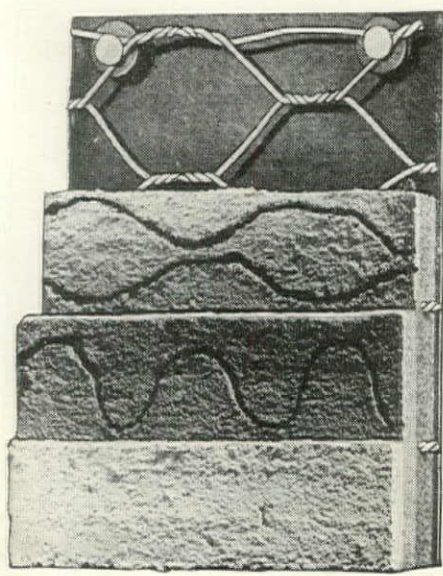

Keymesh is made of strong, copper-bearing steel wire. Lays flat when unrolled. No bumps or bulges to cause uneven thickness of the scratch coat.

The special open mesh design of Keymesh allows each steel wire to be completely embedded in the scratch coat, insuring stucco that is permanently crack-resistant.

Keymesh is easily furred out with special Keymesh furring nails to keep it at a uniform and proper distance from the wall—to insure a scratch coat of full thickness.



KEYMESH HAS BEEN USED ON THOUSANDS OF HOMES SO FAR THIS YEAR



KEYSTONE STEEL & WIRE COMPANY
PEORIA 7, ILLINOIS

"Ad-On" MULTI-BREAKER

TYPE MB-4 SERVICE AND LOAD CENTER

ADD CIRCUITS
Easily, Quickly
At Low Cost



TYPE MB-4 MULTI-BREAKER:

Includes a basic circuit breaker unit providing 4 single pole, 1 double pole and 2 single pole, or 2 double pole circuits in combinations of 15, 20, 30, 40 or 50 amperes making up 33 standard devices. FLUSH or SURFACE mounting with 70 AMPERE MAINS for small homes and 100 AMPERE MAINS for larger homes.

"AD-ON" UNITS: 1, 2, 3, or 4 single pole circuit breaker units rated 15, 20 or 30 amperes are easily plugged in on basic block.

SQUARE D's THERMAL COILLESS MAGNETIC MULTI-BREAKER

● Few homes have enough circuits to serve the many appliances added after the electrical system has been installed. The new Square D MB-4 Service and Load Center provides room for future circuits—simply add on single pole units as needed to connect that new laundry equipment, attic fan, dishwasher, garbage disposer, food freezer or air-conditioner.

Low cost... elimination of separate devices for extra circuits saves equipment, mounting, nipping and extra wiring.

- Replaces fusible switch—provides both circuit protection and disconnect means.
- Gives 2-way Protection—holds harmless overloads—trips fast on shorts.
- Eliminates fuses—nothing burns out—nothing to replace—no live parts exposed. Anyone can quickly restore service.
- Non-tamperable—unit is factory calibrated, tested and sealed. Underwriters approved.
- Simple mechanism—few moving parts—long mechanical life.

See the new "AD-ON" Multi-breaker at your Square D Electrical Wholesaler

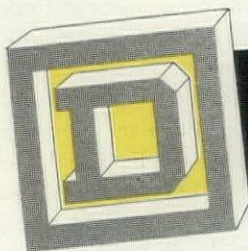

SQUARE D COMPANY

DETROIT

MILWAUKEE

LOS ANGELES

SQUARE D COMPANY CANADA LTD., TORONTO • SQUARE D de MEXICO, S.A., MEXICO CITY, D. F.

Proponents of Neutra Modern and Dutch Barn Architecture Slug it Out . . . Contemporary Architecture in Brazil . . . The High Cost of Labor . . . Hints to the Household Appliance Manufacturer.

OLD SHOE VERSUS GLASS CAGE

In the July issue, FORUM published a letter from Russell Branch, former owner of a house designed by Richard Neutra (FORUM, Apr. '48, p. 113), expressing his disillusionment with modern design and his preference for the "old shoe of a house" in which he now lives. Characterizing his family's earlier status as "victims of the so-called functional," he is now sold on a home with "the general proportions of a Pennsylvania barn . . . where we can have our dirty diapers and our peace of mind." Publication of this letter precipitated a minor explosion from Mr. Branch, Mr. Neutra and from the present owner of the Neutra house, Stanley Frankel, who is more than satisfied with his "glass cage." FORUM herewith presents the case for both the Branch and Frankel way of living documented by at-home photographs (see below and opposite page).—Ed.

Forum:

Inasmuch as The FORUM is read so widely and also by bank appraisers and FHA officials, I expect that Mr. Branch's letter to you will be a well calculated discredit to modern houses. But considering that the house, built for about \$6,000 on a lot worth perhaps a third or fourth, was sold after seven years of use for \$18,500 to people who like it intensely, proves that The FORUM was not amiss in giving it favorable comment, and loan companies would not have to shrink from it as a white elephant.

Ron Partridge Photos

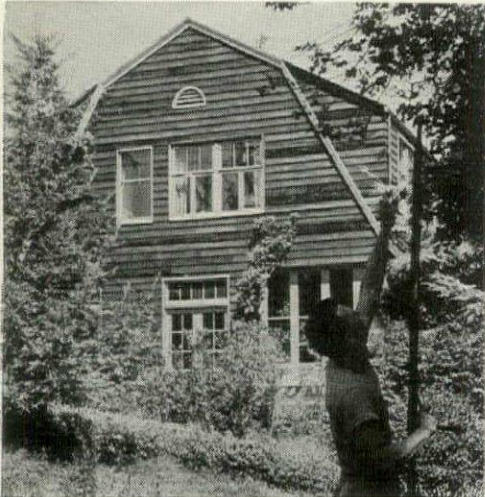

BRANCH: "Not truly a farmhouse, not a castle and not a Roman bath—it is just a house. In my Neutra period I felt insecure when working around the yard because the house seemed ready to take off at any minute."

Excerpts from Mr. and Mrs. Branch's letters . . . would at any rate show that the owner received what he very much desired and apparently to his full satisfaction. For instance, from Mrs. Branch, Jan. 15, '42:

"We want to assure you again that we are absolutely delighted with the whole house. We are constantly thrilled to discover how it meets our every need and like. The little details we've had to mull over are things that are bound to come up when anything is planned with such speed. We've been astounded that, after only one or two conferences with you, you were able to design a house that kept within our small budget but nevertheless suited us so completely."

And again from Mr. Branch, Apr. 20, '42:

"Once again Mrs. Branch and I would like to express our appreciation and our enthusiasm for the home you designed for us. After living here for nearly two months we realize more than ever what a marvelous job you did; for in livability and beauty it has proven to be everything we hoped our home would be. In fact, you have given us much more than we dared hope for considering our cost limitations."

It is not well warranted that a broad reader-public is given the impression—which to many has become a cliché—that things are being imposed by a practitioner in our profession upon an innocent client who is victimized without a voice in the matter. At least in this case, which probably stands for many, the owner spoke his mind during the various planning stages up to the end and the architect took stock

Julius Shulman Photos

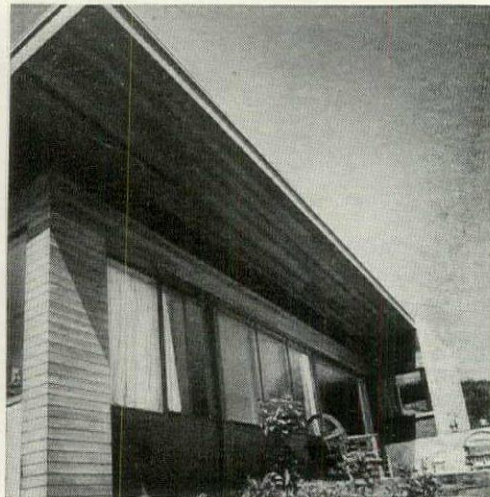

FRANKEL: "A beautiful house which we have found through a year of occupancy to be the utmost in comfort and convenience."

in it, according to the owner's testimony. . . .
Los Angeles, Calif. RICHARD J. NEUTRA

Forum:

My letter regarding Neutra Modern which appeared in the July FORUM was never intended for publication, and finding it there was like suddenly discovering that a private conversation of yours has gone out over a national network.

It is common practice for a writer, before beginning work on an article, to send the editor a "query letter" in which he suggests his personal background and slant on a proposed subject. That was the intended purpose of mine. The fact that it was misunderstood and appeared in print has caused me as much embarrassment as it must have Mr. Neutra, and I'd like now to amplify on it.

(Since Mr. Branch failed to state that his letter was not for publication and, in fact, remarked: "I'd just like to tell your readers why Two Smart Young Things moved to Pennsylvania Dutch from Neutra Modern," FORUM can only regret that its editors are not gifted with mental telepathy. They were also unable to divine that Mr. Branch's many declarative sentences constituted a "query letter" for a future article of his own which he did not mention.—Ed.)

Both my wife and I still feel that the house which Richard J. Neutra designed for us was a splendid realization of the ideas which we took to him in 1941. He gave us exactly what we wanted then; in fact he gave us even more than we had hoped for, considering our small budget and construction difficulties at the time.

If our ideas have changed since then, it has been in spite of our regard for Mr. Neutra and not because of him. His dwellings—as I think he'd be the first to admit—illustrate a philosophy and propound a certain way of life. It is that way of life, rather than Mr. Neutra's unassailable ability as an architect, which I question now after finding another type of living and, essentially, another mode of life.

Let me put it this way. If a friend of mine came to me and said he wanted modern, I'd tell him: "Go to Neutra, you can't do better."

But first I'd ask that friend: "Are you sure you want modern? Do you really want stark lines and slick surfaces and a way of life planned to the last efficient inch? Do you realize that an old-fashioned house can also be functional; that it may, in fact, function even better for families such as mine . . . and yours?"

Santa Cruz, Calif. RUSSELL BRANCH



BRANCH: "On a limited budget, you can furnish a house more attractively in traditional style. Oddments from relatives' attics will fit somewhere in almost any traditional home. We also feel that our modern furniture fits better in the farmhouse than traditional furniture would in the Neutra house."

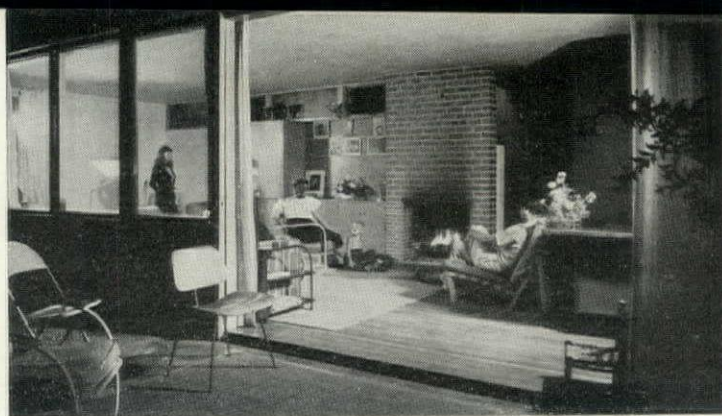

FRANKEL: "We particularly like the living room arrangement. A sliding door between interior and the yard (especially welcome in the California climate) makes indoors and outdoors one living area."



BRANCH: "Plenty of room though not perfectly organized, the kitchen includes an old-fashioned pantry for storing canned goods and separating milk and cream from our own cow. A family can have more space for the same dollars if they're willing to put up with inconveniences."

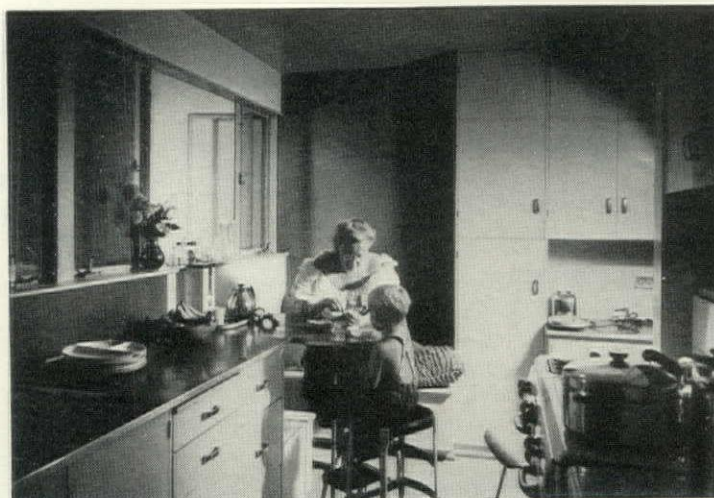

FRANKEL: "High utility to cost ratio. The long bank of windows on the left makes the children's play yard as well as the mountains visible from any part of the kitchen."



BRANCH: "Door frames and wainscoting serve as protectors against children and moving men. In the farmhouse the youngest child runs his greasy hand along the wall as he comes downstairs. Result: no damage."

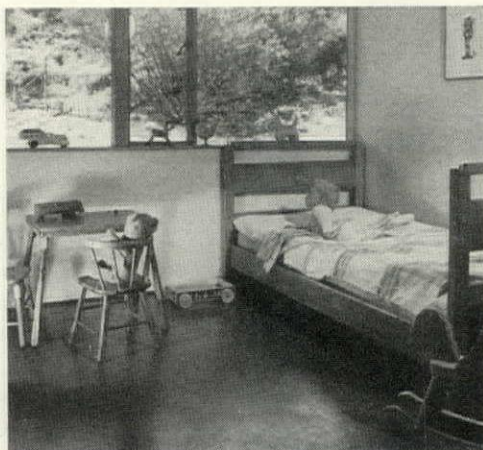

FRANKEL: "A one-floor layout without stairs is a distinct advantage for the busy housewife with young children."

Forum:

I feel obliged to express my opposition to the views apparently now held by Mr. Russell Branch about the "Neutra modern" masterpiece he sold us a year ago. From the standpoint of the young family it seems to me to present advantages unobtainable in traditional homes. Aside from its high utility-to-cost ratio this house appears to me, after a year of residence, to have several unusual virtues: First, its flexibility—any point of the house can be reached by at least two routes. That is because the house is built around a central storage core with little waste wall and hall space. Sec-

ond, my wife rejoices in being able to look at the outside world instead of just at a wall in whatever room she chooses for a current job—and in the Santa Monica mountains that is indeed pleasant. Third, when we are in the kitchen or living room the small fry are either audible or visible whether they choose the house or any part of the yard in which to play.

Beyond this, it is our firm conviction that the former Branch house is purely and simply a thing of beauty and we rejoice in our possession of it.

STANLEY FRANKEL

Hollywood, Calif.

Forum:

I was shocked to read the letter written by the former owner of the Neutra house in which he wrote of his original enthusiasm and then voiced dissatisfaction as to the livability of his home.

I do not know why the former owner sold his home to move into an old Dutch rambling house, but in fairness to one of the outstanding architects in the world and as a most enthusiastic owner of an 11 year-old Neutra designed home, I feel that I must give my feelings as to the livability and salability of our home.

Our home has been a source of constant happiness. Everyday we still find things that make us realize just how conscious Mr. Neutra is of small details that make for ease of living. We have had two children and have gone through the soiled diaper period, the toddler stage, and now grammar school stage. With each stage we have felt most thankful for the conveniences, ease of cleaning, and beauty of our home. All of our friends are envious of us and many are making plans to build a home like ours.

During the war, we rented our home when we went to join my husband who was stationed in Quantico, Va. The tenants showered us with gifts and thanked us for the privilege of living in the house.

These are perhaps idealistic thoughts, but just to mention the material side. We

(Continued on page 30)

LETTERS

cut your home
building costs

with an

A-P OILIFTER!

The A-P OILIFTER helps you to a completely modern AUTOMATIC heating installation — with today's lower cost, more economical vaporizing oil burning furnaces and floor furnaces. Makes your homes more salable at a saving of several hundred dollars!

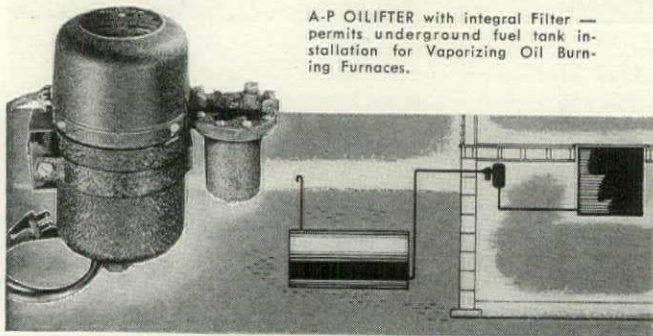

A-P OILIFTER with integral Filter — permits underground fuel tank installation for Vaporizing Oil Burning Furnaces.

With an OILIFTER, fuel storage tanks need not be limited to furnace-level, gravity feed installation. Tank may be installed underground outdoors, completely out of the way, without taking up valuable space in your compact house plan. The OILIFTER "lifts" oil as high as the third story or horizontally as far as 100 feet to the furnace, at a capacity as high as 1 1/4 gallons per hour.

Plan Now on using Vaporizing Oil Burning Furnaces in your new homes — with A-P OILIFTERS. You save on original furnace cost and, with an A-P Heat Regulator Set, can provide your customers with modern AUTOMATIC Heating that offers steady comfort with less oil consumption.

A-P Heat Regulator Set provides Thermostatic Temperature Control.

WRITE TODAY for specifications and literature on A-P OILIFTER and A-P Heat Regulator Sets.

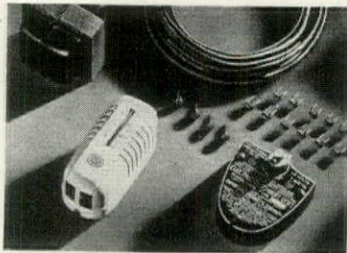

AUTOMATIC PRODUCTS COMPANY

2530 NORTH THIRTY-SECOND STREET
MILWAUKEE 10, WISCONSIN

A-P DEPENDABLE Oil Controls
designed to eliminate servicing



have had many offers to buy our home and turned down a concrete offer of \$30,000 for our \$11,000 investment. I understand that the home in the April issue was sold for a huge profit also.

I hate to feel that the progress of architecture might be hindered by someone who may have had a severe stomach ache and relieved his pains at the first thing he thought of—true or not.

HELEN BARSHA

North Hollywood, Calif.

AUGUST GLOW

Forum:

The article on American Community Builders (FORUM, Aug. '48) was a honey!

Chicago, Ill.

ALAN J. JACOBS

Forum:

I have just read the article on our plant (FORUM, Aug. '48, p. 13) and would like to congratulate you on its accurate and able description. Because of the tremendous public interest in defense facilities at this time, there has been a great deal of distorted reporting on our plant, and I believe your article will go a long way to correct some of these misstatements.

C. R. HELLSTROM, President
Smith & Wesson, Inc.

Springfield, Mass.

Forum:

You must get compliments from all over the world on the extremely high standard of your publication. May I add to the expressed opinions of this world-wide group my own compliments on the outstanding publication.

JOHN R. PRICE, Managing Director
Payne Bros. Department Store

Durban, South Africa

BRAZILIAN BOOK

Forum:

Though he may be 100 per cent correct in his review of the book *Contemporary Architecture in Brasil* (FORUM, June '48), I am sure, had M. S. realized the many obstacles to be surmounted in the publication of such a volume in Brazil, he would have been a little less harsh on this sincere effort to put out an honest-to-goodness Brazilian book, of Brazilian work, by Brazilian publishers, for the Brazilian market . . . and whosoever desires to purchase a copy "for the cult of the indigenes beyond control."

An amusing sidelight of the review in itself is the fact that there was no trans-

(Continued on page 32)

fluorescent medicine cabinets
concealed units

by

HALL-MACK

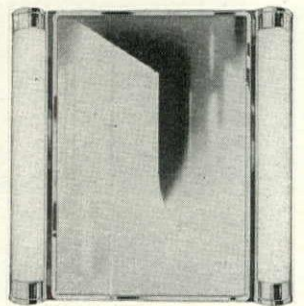

Complete line of fluorescent medicine cabinets with seamless bodies, porcelain finish, piano hinge doors and top quality mirrors illustrated: No. FLP-1826.

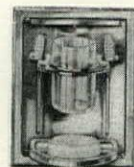

Open



Closed

Concealed lavatory unit, No. 338. Keeps soap, tumbler and tooth brush out of sight when not in use, avoiding unsightly, unsanitary exposure.

For Quality in every detail — in materials, craftsmanship and installation — look to HALL-MACK for the very best. Famous, not only for medicine cabinets but for complete lines of bathroom accessories covering all price ranges. See Sweet's Catalog.

HALL-MACK COMPANY

1344 W. WASHINGTON BLVD. • LOS ANGELES 7, CALIF.
7455 EXCHANGE AVE. • CHICAGO 49, ILL.



How about **ALUMINUM CONDUCTOR** for industrial wiring?

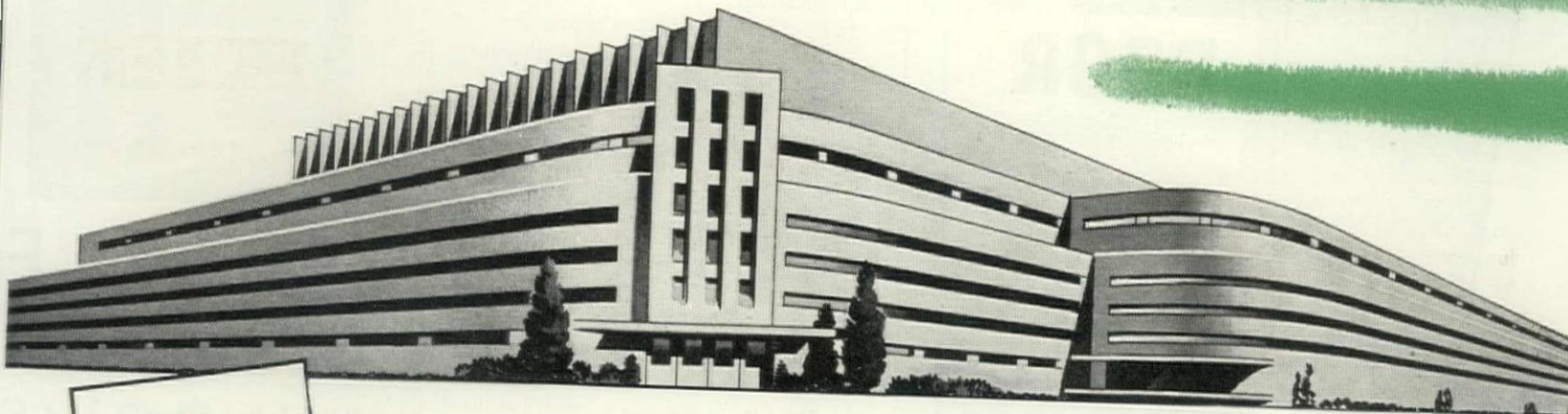

Aluminum shows greatest savings in big industrial plants where conductors are large



In big industrial plants, conductor *metal* is often the large factor in cable cost. Here aluminum shows its greatest savings—running into thousands of dollars on a single job.

Industrial clients, faced with rising costs on every other front, welcome the savings made possible when you *figure it in aluminum*. Lower cable cost, easier and faster installation, lower transportation costs, all add up to important over-all savings. No departure from your established engineering practices required—except where, in some cases, aluminum's lighter weight eliminates the need for extra supports.

Light, strong, conductive Alcoa E. C.* Aluminum is drawn, stranded, insulated and sold by leading wire manufacturers. ALUMINUM COMPANY OF AMERICA, 1475 Gulf Building, Pittsburgh 19, Pennsylvania.

*E. C.: Electrical Conductor Aluminum

YOUR SUPPLIER HAS IT

ALCOA EC ALUMINUM



FOR ELECTRIC WIRE AND CABLE

Insulated and sold by leading wire manufacturers



LETTERS

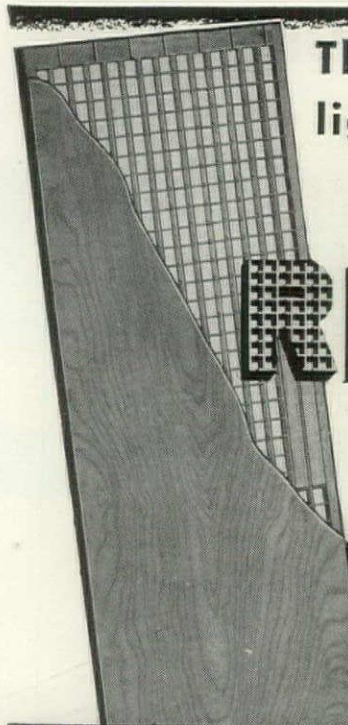

The stronger,
lighter, better

PAINE REZO DOOR

*costs
your client
nothing*

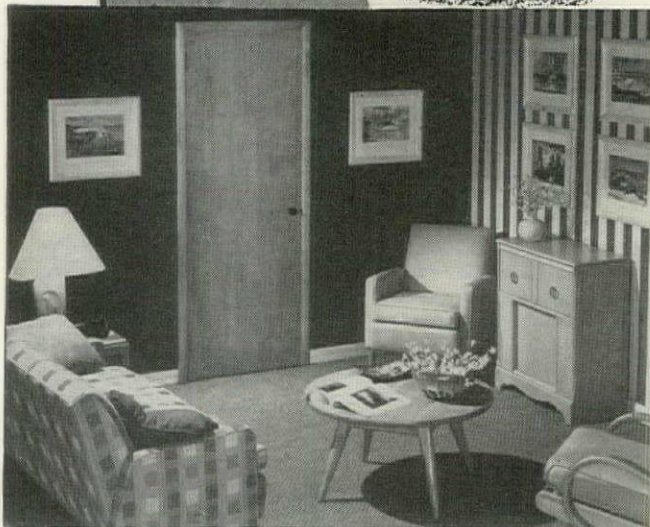

At no extra cost, your client receives in the hollow-core Paine Rezo door patented structural advantages that for all-time minimize warping and shrinking while they add great strength to lightness in weight. This means a door that is free from trouble, that will always be a credit to your judgment in specifying it.

Because 1 3/4" Paine Rezo doors are pre-fitted and light-in-weight they are quickly hung. To these savings add one more . . . a smooth, flush surface that is painted or stained in less than half the time required by ordinary panel doors. That's why Paine Rezo's are yours without a premium, why you can give them to building owners at a total installed cost that is no more than that of common panel doors. No wonder, then, that over 2,000,000 Paine Rezo doors are in service today, specified by architects from coast to coast.

A concise four-page bulletin packed with architectural data to save you time has been prepared. You'll find it in Sweet's File, or it's yours for the asking. Write

Manufactured by the
PAINE LUMBER CO., Ltd. *Oshkosh, Wisconsin*
ESTABLISHED 1853

lator of the Portuguese thereof ("Published by Organizado Pela Revista Ante-Projeto," which incidentally, means "Published by Organized By The Magazine Ante-Projeto"), and that The FORUM Brazilian issue was erroneously attributed to Nov., '41, instead of 1947. For the record, the book is published by the Editora Gertum Carneiro S. A., Rio de Janeiro, Brazil, and organized by Ante-Projeto, an architectural magazine edited by former students of the old Escola Nacional de Belas Artes, of the Universidade do Brasil.

A. P. DE ALBUQUERQUE
Department of Architecture
University of Kansas

Lawrence, Kansas

Forum:

. . . You are, unfortunately, right. The book is not worth being bought by American architects, and the publication is sub-sub-standard.

However, you are wrong supposing that there are no Brazilian architectural magazines. There are no publishers or editors who are able to manage a good European or American-standard review, but there is a lot of "entusiasmo" among students and draftsmen and younger architects about publishing of architectural magazines.

. . . Maybe in 1949 we will start a good Brazilian Architectural Review, quarterly published, with the collaboration of Niemeyer, Rino Levy, Marcelo Roberto, Artigas, Mindlin, Warchavchik, Kneese, Mello, Alvaro Vital Brasil, etc.

Thank you for your kind interest in the publications of this country. You may believe that we do our best.

GERTH TODTMANN

Sao Paulo, Brazil

REPUBLICAN REPLY

Forum:

My sense of fairness forces me to reply to "Name Withheld—Chicago, Ill." I too am one who got out of the building game—but not because the Republicans did not get out the New Deal housing gravy train again. I got out because the New Deal Administration, which you evidently condone, has brought about an "impasse" in building. This has been done by governmental paternalism toward union labor in the building trades and elsewhere for 15 years; and allowing them to raise wages year after year to asinine highs and at the same time progressively cutting down on the amount of work done per man per day. The result—no housing—and there won't be, until these "half-baked" politicians and racketeering union leaders are put where

(Continued on page 34)

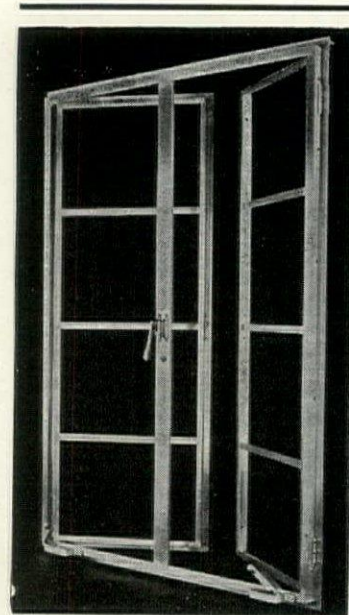

WARE ALUMINUM WINDOWS

THEY ARE LIGHT IN WEIGHT
YET RIGID AND ALWAYS IN
ALIGNMENT

THEY ARE OF HEAVIER
SECTION THAN USUAL

THEY NEVER NEED PAINTING

THEY ARE STORM TIGHT

(Tests show NO AIR INFILTRATION
at 25 to 40 miles per hour, and
0.76 cu. ft./min./per. at 59 m.p.h.)

Write for details

WARE LABORATORIES, Inc.

1827 Delaware Parkway
New York: 21 West Street

Miami 35, Fla.
Whitehall 3-6866



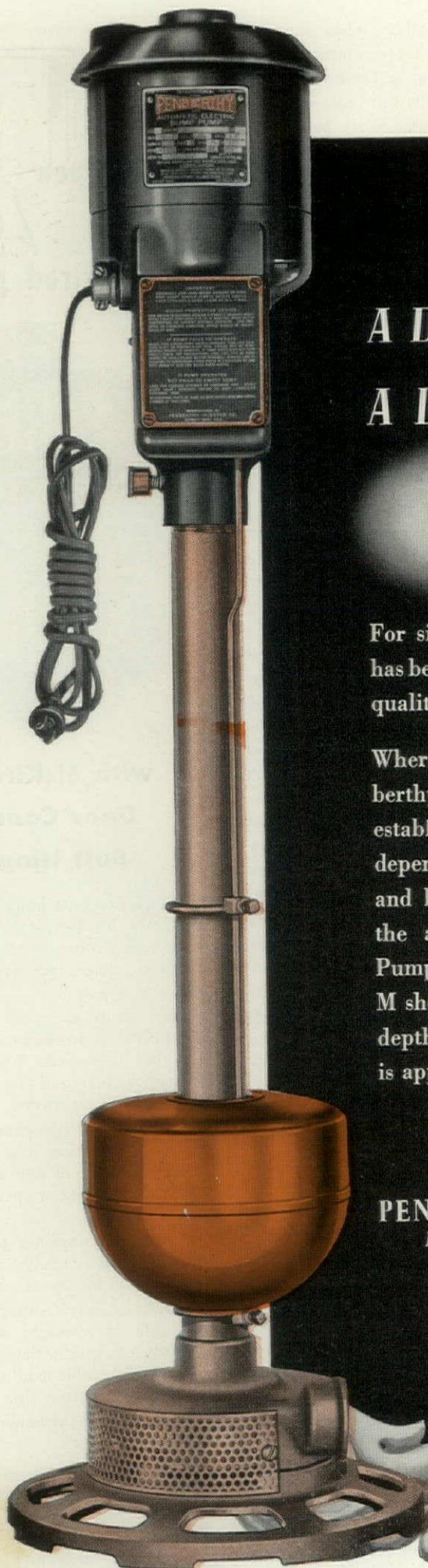

A Distinguished Name...

A Distinguished Product

**PENBERTHY
AUTOMATIC ELECTRIC
SUMP PUMPS**

For sixty (60) years, the name "Penberthy" has been associated with products of the highest quality.

Wherever seepage water accumulates, Penberthy Automatic Electric Sump Pumps have established an outstanding reputation for dependability and long life. Made of copper and bronze throughout, they are immune to the attacks of corrosion. Penberthy Sump Pumps are available in three types; the Model M shown here is made for five different sump depths. They are preferred wherever quality is appreciated.

**CONSTRUCTED OF COPPER AND
BRONZE THROUGHOUT**

PENBERTHY INJECTOR COMPANY

Manufacturers of Quality Products Since 1886

DETROIT 2, MICHIGAN

Canadian Plant—Windsor, Ontario

LETTERS

Q.—What caulking compound for Bullock's Pasadena?



Bullock's new store in Pasadena, Calif.
Wurdeman & Becket, Architects.
(Photo by "Dick" Whittington)

A.—KAUKIT...

the caulking compound you specify and use when you want TOP PERFORMANCE

Yes, wherever caulking was necessary to assure weather-tight window frames, door jambs and steel sash, KAUKIT was the answer for Bullock's great new store building in Pasadena, Calif.

Why? Because KAUKIT cures to a tough, airproof, weatherproof film on top, yet remains elastic and pliable underneath. It expands and contracts with changing temperatures, yet doesn't crack, chip or crumble. KAUKIT gives long-lasting adhesion to wood, metal, glass, masonry, other building materials . . . won't sag, slump or run out of joints.

Ready to use — easily workable — color-fast. Available in gun and knife grades — cartridges, too.

P. S. — Are You "Weatherizing" Exterior Walls?

Another Sonneborn product used in "weatherizing" buildings is HYDROCID Colorless — invisible water-repellent treatment for exterior concrete and masonry walls above grade. Two types: "G" for relatively dense surfaces; "D" for porous, light colored surfaces.

See SWEETS's for further information, or write Dept. E9 for free folder on KAUKIT or HYDROCID Colorless.



SONNEBORN

"BUILDING SAVERS"

If It's Worth
Building It's
Worth Saving

Floor Treatments • Waxes • Paints and Protective Coatings
Concrete and Mortar Admixtures • Waterproofing and Dampproofing
Caulking Compound • Roof Coatings

Building Products Division **L. SONNEBORN SONS, INC.** New York 16, N. Y.

In the Southwest: Sonneborn Bros., Dallas 1, Texas

they belong—in limbo. When you can't build houses without government subsidies something is rotten in Denmark, and it didn't happen in this last session of Congress. It started some years before that, and Ex-President Hoover is not to blame. You guess who. You can't give away the country's substance without paying the bill.

Chicago, Ill.

ALBERT M. WOLF

FORUM, whose editorial schedule has contained many a story on how to beat the high cost of labor, is amused at Reader Wolf's assigning "half-baked politicians and racketeering union leaders" to limbo—according to Webster's "the abode of souls barred from heaven through no fault of their own, especially the souls of just men who died before the coming of Christ." —Ed.

CALLING USONIA

Forum:

Ever since I subscribed to your magazine last September, I have looked to each issue with greatest anticipation and find your publication as invigorating and stimulating as any offered. I could never begin to give to the Frank Lloyd Wright issue due praises, and put aside of the 1938 monograph, the two stand as periodical landmarks in art. And now that there is no doubt about the genius and greatness of the Master, you, you who have lent two such helping hands, should not stop at those issues. Many other architects' works that you publish show definite Wrightisms. Why do you not go back and publish more often the origin of these characteristics? You have gallantly printed many of his daring projects, but what about the Usonian homes that his brain is continually producing? The average man in the street associates Frank Lloyd Wright with the almost legendary creator of houses that fly over waterfalls, buildings that ride the vast grass prairies, buildings held up by golf tees, homes that sprawl all over Connecticut hill-tops, and art museums that go zip zip zip up in one seven floor spiral. Or hotels that float on mud. Since you are the leading architectural organ in this country, why not take it upon yourself to publish at least one Usonian home each month, plans and photographs of the completed project, with data (a price). You have the power to stop the chain of thought regarding Mr. Wright as an architect who builds only when he can use his client's wallet like the Bank of America. Let the public see the other side of Wright. Surely one Usonian home each month can do no harm. To your circulation, that is. . . . So many people I have shown the January issue to asked of each Usonian Home: Is it built? How much?

(Continued on page 36)

Doors
will
stay open
in
any desired position

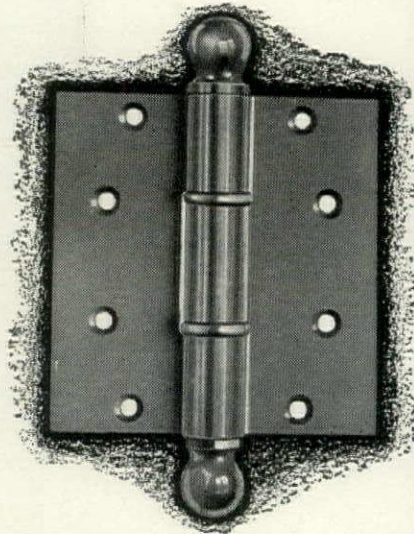

with McKINNEY Door Control Butt Hinges

These quality butt hinges are designed especially for hospitals, institutions, schools, and other buildings where dependable, quiet, positive-acting door service is required.

They assure the quiet and efficient door operation so essential to hospitals and other institutions. They control the swing of the door and prevent slamming by drafts or by persons.

The door may be opened to any desired position, where it will remain stationary, in spite of any air currents—yet it can be closed or opened with very little effort.

There are no springs to get out of order. Tension is readily adjustable on the door with the use of a small wrench.

McKinney Door Control Butt Hinges are made of wrought steel—highly polished—equipped with phosphor bronze bearings. Available in all standard sizes—with ball or button tip.

Constructed on the famous McKinney standard of quality.

See Sweet's Architectural File
for details or write

McKINNEY
MANUFACTURING COMPANY
PITTSBURGH 12, PENNSYLVANIA

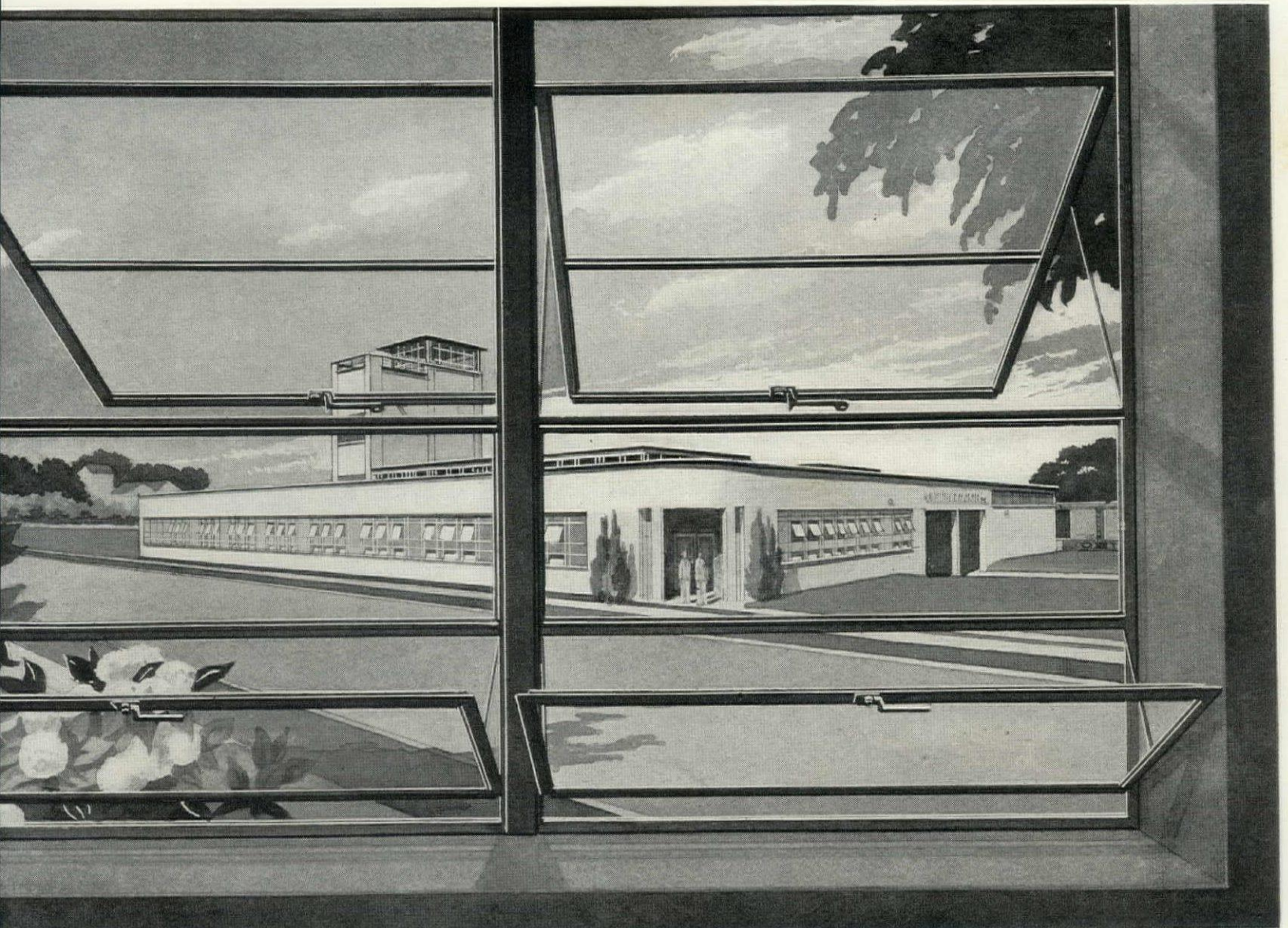

Economics Laboratory, Inc., Lyndhurst, N. J. Walter Kidde Constructors Inc. of New York City, Engineers and Builders.

The makers of "Soilax" selected Lupton Architectural Projected Windows to obtain all the benefits of modern window design in their new plant at Lyndhurst, N. J. which exemplifies the modern trend in industrial construction. Here, Lupton Metal Windows add graceful appearance, give a greater abundance of daylighting, and controlled, year-round ventilation. Smartly-designed operating hardware is an added feature of Lupton Metal Windows. Low initial cost and outstanding durability make Lupton Architectural Projected Windows ideally suited for school, office or commercial buildings. Bronze wire screens can be furnished with open-in or open-out ventilators. There is a Lupton Metal Window for every type of building. Write for our catalog or see it in Sweet's.

MICHAEL FLYNN MANUFACTURING CO.
700 East Godfrey Avenue, Philadelphia 24, Penna.
Member of the Metal Window Institute

LUPTON METAL WINDOWS

Koven WATERFILM BOILERS

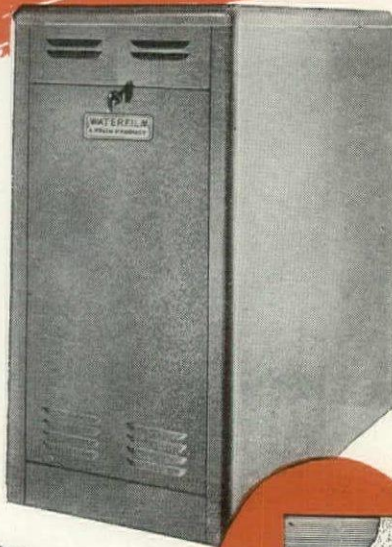

THE HEART OF THE WATERFILM BOILER IS THE ZIG-ZAG SHAPED WATER TUBE

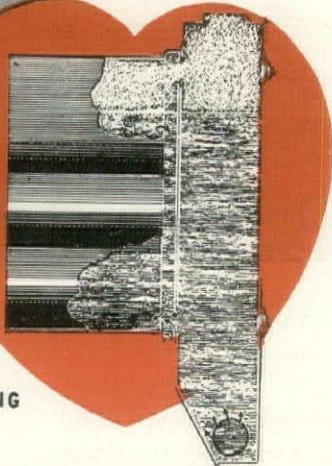

- Patented Construction
- Quick-Steaming
- Retards Accumulation of Soot
- Economical
- Rugged Construction
- Easily Replaced

THE FASTEST STEAMING BOILER MADE

FOR ECONOMICAL, QUICK HEAT!

Feature efficient, fuel-saving WATERFILM BOILERS in models and sizes for small homes, apartment houses and industrial plants. In demand everywhere, WATERFILM'S exclusive patented construction insures faster steaming action than any other boiler made, allows even temperature in every room and supplies plenty of domestic hot water at all times.

For larger installations, recommend the Sectional Boiler that goes through a 2-ft. door, can be assembled without expensive alteration or rigging costs and is easily enlarged by adding sections.

500-17,850 E. D. R.

Write for free literature and newspaper mat service. **NATIONALLY ADVERTISED**

WATERFILM BOILERS, Inc.

A Division of L. O. Koven & Bro., Inc.
154 Ogden Ave., Jersey City 7, N. J.

EVEN ROOM TEMPERATURE THROUGHOUT THE HOUSE!

FOR AUTOMATIC FIRING WITH OIL, STOKER OR GAS

If the American public is to be convinced of the sincerity and beauty, practical beauty, of Frank Lloyd Wright, they must see that he can solve our greatest problem: how to build a home without the Vanderbilt millions. . . .

Let's pay due homage to a Great Master, before we all regret it.

BRUCE BROOKS PFEIFFER

Framingham Center, Mass.

See p. 16, this issue.—Ed.

BLACK LIGHT

Forum:

The article on "Lighting with Paint" (FORUM, June '48) is of great interest to me because my brother and I were directly responsible for the first successful use of "black" light for night club decoration, some 13 years ago. . . .

The Architectural FORUM is to be congratulated on the accuracy of the article and on the clear exposition of the difference between fluorescent and phosphorescent materials. The color illustration (p. 126) is excellent but the Avalon installation does not begin to suggest the full possibilities of the "black" light medium. There is actually not much point in using fluorescence to produce a starred ceiling because better stars can be arranged at lower costs by the old-fashioned method of cutting apertures and lighting them from above. Moreover, it is our feeling that fluorescent murals are most striking when used to depict a subject which would naturally glow with light. For example, moonlight scenes, desert views, astral subjects and night views of cities are superb when depicted in "black" light.

ROBERT C. SWITZER, President
Switzer Brothers, Inc.

Cleveland, Ohio

HOUSEHOLD HINTS

Forum:

I know The FORUM is read by many manufacturers of household appliances. For this reason I am submitting to you this "open letter" in the hope of calling needed attention to what should be obvious faults in kitchen appliance design.

Today's high square foot construction cost makes it essential to plan kitchens for utmost economy in use of space, and at the same time to achieve efficiency in the proper placing of equipment. It is impossible to make a really integrated kitchen when the various units cannot be properly fitted together without unsanitary joints between them. . . .

For example, take the range. With the exception of one make, all ranges, to my

(Continued on page 38)

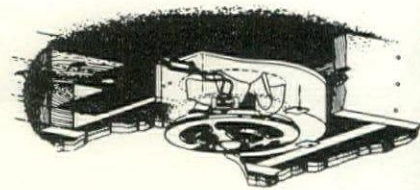

WOMEN LOOK UP TO Blo-Fan

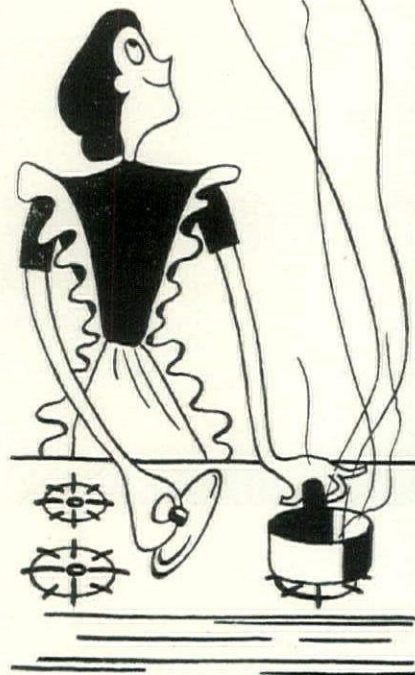

BLO-FAN equipped kitchens benefit Mrs. Housewife 6 ways. Ask the woman who has one.

1. Ceiling installation, directly over the range, where a fan belongs.
2. Elimination of unpleasant cooking odors, greasy walls and foul, contaminated air in the house.
3. Minimizes house cleaning and redecorating.
4. Minimum ceiling opening, attractive grill.
5. Blo-Fan combines the efficiency of a fan with the power of a blower.
6. Trouble-free operation assured by totally enclosed motor, cooled by the air stream.

It's an architect's job to provide functional design in the kitchen...Look up to

Blo-Fan

ELECTRIC CEILING VENTILATOR

for the most efficient ventilation

PRYNE & CO., INC.

POMONA, CALIFORNIA
LOS ANGELES, CHICAGO
SAN FRANCISCO
NEW YORK

What's your score?

(A three-minute test on the effective use of wiring materials)



1 Existing service entrance consists of 3/4-inch conduit, containing two No. 8 Type R wires. How can this installation be made suitable for an electric range, without tearing out the conduit?

- A** — Install a second service entrance.
- B** — Run two No. 6 Type T wires and one bare No. 8 conductor in existing conduit.
- C** — Tap into the next door neighbor's circuits.



2 An electric device that can be seen but not heard helps any builder or architect to sell good wiring to clients. What is it?

- A** — Electronic toaster.
- B** — Mercury switch.
- C** — Piped light.



3 Many electricians are saving time in box installations on residential wiring jobs. How are they doing this?

- A** — By using precut wooden spacers.
- B** — Through the use of S-type bar hangers.
- C** — By nailing boxes directly to the plaster.



4 Even "cool" fluorescent lighting sometimes must withstand fairly high ambient temperatures. What would you choose to safeguard such installations?

- A** — Air conditioning.
- B** — Cold cathode.
- C** — Deltabeston* fixture wire.

Answers

1 Okay, if you chose **B**. And you'll be wise to make it General Electric thermoplastic every time you choose a building wire, because General Electric has always been a leader in the production and sale of thermoplastic insulated wire.

2 General Electric's silent mercury switch makes **B** the only correct answer for modern planners. It is now T-rated at 10 amperes, 125 volts, and is a beauty to look at in any installation. Lasts a while of a long time, too.

3 Pick **B** for this one. G-E S-type bar hangers are made to fit framing spaced from 6 to 24 inches. A new, heavy-duty stud affords ample support for any modern fixture.

With a G-E S-type hanger, a box can be located on the bar at any point between studs simply by tightening a single screw.

4 If you picked **C**, and specify it for your "hot" jobs, you won't go wrong. In fact, always say Deltabeston when heat is a problem in wiring installations.

We hope this little quiz was fun. And maybe it will give you a better picture of General Electric Construction Materials—the full line for all wiring needs. Each part of the line is made for ready use with other G-E wiring materials. It's a line that has been designed for convenience—in specifying—in installation—and in maintenance. And it is backed up by experienced men who are always ready to help you with engineering and application counsel on your every project. It's the kind of *one source, one complete line* service that makes it easy for you and your clients to do a top-notch wiring job. If you want information on any of our products, please write to Section K6-104, General Electric Company, Bridgeport 2, Connecticut. * Trade-mark Reg. U. S. Pat. Off.

Construction Materials

GENERAL ELECTRIC

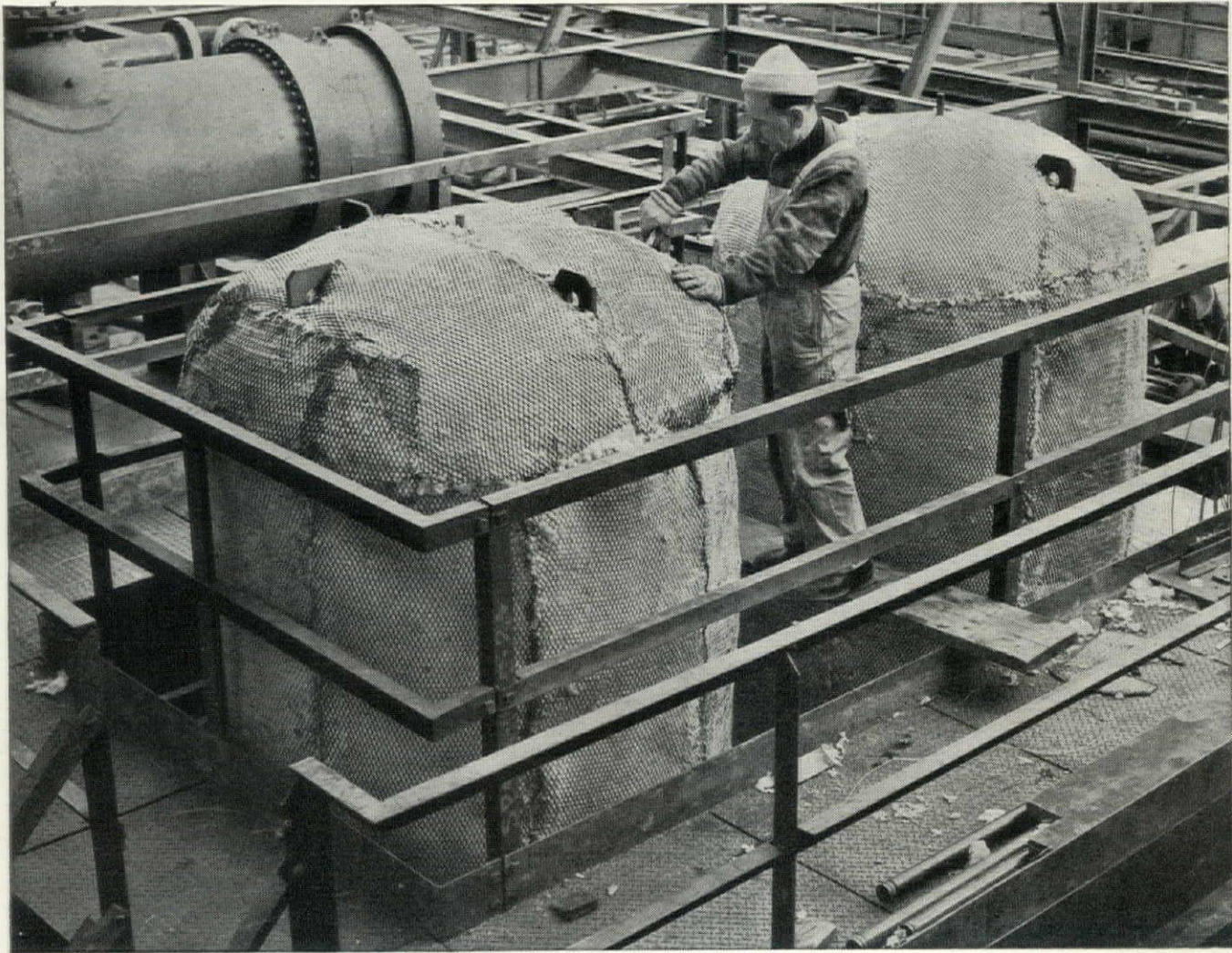

FIBERGLAS* ... form-fitting fuel-saver

Efficient Fiberglas Metal Mesh Blankets are money-savers right from the start. They're extremely easy to apply—even on the most irregular and complex surfaces. And regardless of the application—boiler, retort, oven or tank—these insulating blankets can be depended upon to do an outstanding job of saving heat and keeping fuel costs down.

The high thermal insulating efficiency of Fiberglas results from the countless tiny air spaces enclosed in a lightweight, wool-like blanket of long, fine fibers of glass—a material that will not burn, rot or decay. It's non-corrosive; will not corrode metals. Fiberglas insulation holds together, is resilient, does not settle

under vibration.

This basic material is further processed into blankets that meet all industrial requirements for insulating hot surfaces—up to 1000°F. When fabricated with a metal mesh exterior, the surface not only facilitates application but also provides a base for insulating and finishing cements.

If you want the *best* in efficient, economical, easy to apply insulation, get all the facts on Fiberglas blankets—their many forms and uses. Write for "Fiberglas Insulations for Industry", Owens-Corning Fiberglas Corporation, Dept. 830, Toledo 1, Ohio. Branches in principal cities.

In Canada: Fiberglas Canada Ltd., Toronto, Ontario.

OWENS-CORNING
FIBERGLAS
THE FIBERGLAS COMPANY

**THERMAL
INSULATING
MATERIALS**

*Fiberglas is the trade-mark (Reg. U. S. Pat. Off.) for a variety of products made of or with glass fibers by Owens-Corning Fiberglas Corporation.

LETTERS

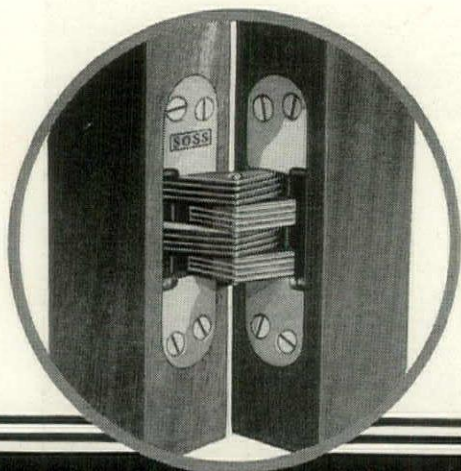

THE HINGE that hides itself

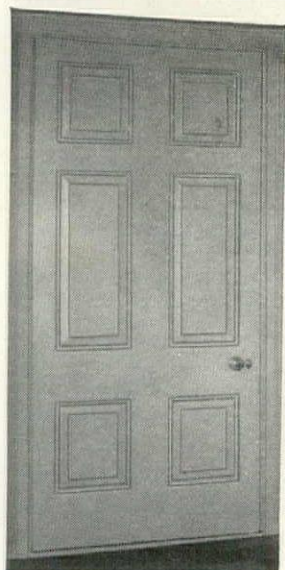

● Soss Invisible Hinges do just that. They are actually mortised in the door where a hinge belongs. There are no ugly, protruding hinge butts to mar the streamlined beauty, the graceful lines of modern architecture. Flush, smooth interiors are assured because the Soss Hinge is completely out of sight. No home is really modern without Soss Hinges.

These rugged, precision built hinges are sturdy, durable and operate smoothly and silently. Your clients will appreciate Soss Hinges because of their outstanding qualities and the modern touch they provide.

There is the right Soss Hinge for every kind of door, panel, and cupboard. Write for the Soss "Blue Print Catalogue" giving full details of the many uses of this modern hinge. This catalogue free on request.

SOSS MANUFACTURING COMPANY
21779 HOOVER ROAD • DETROIT 13, MICHIGAN



BRITISH PHILIPPIC

Forum:

Most of the contents of your magazine are of very little use to a British architect and much is of no use to any architect. The issues of Nov. '47 (Brazil) and Jan. '48 (Wright) are notable and laudable exceptions to the above.

But too much is presented with equal and considerable emphasis, regardless of quality, with far too little comment or criticism. I gain the impression that someone is trying to sell me something I don't like.

Which brings me to another point: The FORUM (and, I suspect, other technical periodicals) is like a sponsored program of the type that nauseated us rough islanders from Luxembourg radio before the war. I like to read what folks have to say to the editor without having to search through several pages and odd columns of unattractive advertisements to pick up the thread of a sentence.

Several of your correspondents ram our "Architectural Review" down your throat and rightly so, say I . . .

You see, Mr. Editor, the British architectural press admittedly covers far less (in comparison) of the building world than The FORUM does of America, but it covers it with infinitely greater intensity and criticism than its New World counterpart. No one I know who had read the issues (except perhaps one of your recent correspondents) liked your way of dealing with 40 houses and 40 shops in two numbers. We would have preferred full details on three or four of each in the manner of "A China shop in Copenhagen" (*Architectural Review*, June '48, pp. 269-271).

However, please don't take me too much to heart. My attitude towards the American architectural press would be thought wrong by at least 80 per cent of your readers, I have no doubt.

Liverpool, England (Name Withheld)

Well, that's a load off our minds!—Ed.

NORRIS ELECTRICITY

Forum:

The article on the town of Norris, Tenn., (FORUM, July '48, p. 13) states that the average cost for electricity to the residents is about \$2 per month. Actually, the average residential electric bill is \$9.14 a month.

W. L. STURDEVANT
Director of Information
Tennessee Valley Authority

Knoxville, Tenn.

In its electrical average FORUM did not include the cost of heating which brings the price up to \$9.14.—Ed.

here's
how

WELBIT GAS RANGE

fits
into
your
plans



DESIGNED to fill
your specifications

BUILT to satisfy
your customer's demands

SHIPPED to meet
your construction deadlines

PRICED to hold
your costs DOWN

For City and L.P. (bottled) gas.
A.G.A. Approved

Send for complete specifications, NOW!

WELBIT STOVE CO., Inc.

Maspeth, L. I., N. Y.

Please send me complete specifications for the Welbilt line of gas ranges.

Name

Address

City

State



RADIANT GLASS HEAT

the new miracle of radiant heating!

This new method of home heating answers the demands of the Builder, the Architect and the Homeowner. The original installation of an average six-room house insures a saving of 50% or better over conventional heating systems. Thermostatic "zone control" gives additional operating economy and insures heat where and when wanted.

THE BUILDER — The builder can build and sell his new house cheaper as there is no need for cellars, utility rooms, storage tanks, boilers or chimneys.

In existing buildings, these panels can be installed for supplementary heating without tearing out walls or partitions and may be connected with present A. C. or D. C., 110 or 220 volt wiring.

Installation of this type of heating is adaptable to apartments, stores, office buildings and any type of edifice where electricity is available.

THE ARCHITECT — Now, the architect can plan his homes with the assurance that the heating installation will be an architectural and decorative asset rather than a liability.

The plate of tempered glass with its fused aluminum element is handsome and the frame can be painted to match any decor.

In buildings other than homes, greater freedom of planning and decoration is given the architect with this simple type of heating.

THE HOMEOWNER — The homeowner will appreciate Radiant Glass Heating for it involves no maintenance or replacement costs. The housewife will enjoy the freedom from dust, soot and oily films and "cold wall" streaks.

Thermostatic "zone control" insures economy of operation in new houses and the elimination of cold rooms in existing houses.

There is no danger of short circuits or explosions. Radiant Glass Heating units have been underwriter approved.

Investigate today. Radiant Glass Heat will enable you to provide your clients with cleaner, safer, more satisfactory heat at a tremendous saving! Fill in and mail the coupon below.

MAIL COUPON TODAY!

Continental Radiant Glass Heating Corp.
Dept. 2A, 521 Fifth Avenue, New York 17, N. Y.

For additional information on this new wonder-heat, and without any obligation on your part, fill in and mail this coupon today.

NAME _____ (PLEASE PRINT)

COMPANY (IF ANY) _____

ADDRESS _____

CITY _____ ZONE _____ STATE _____

**LONG ON LIGHT • LIGHT ON MAINTENANCE
AND INSTALLATION COSTS**

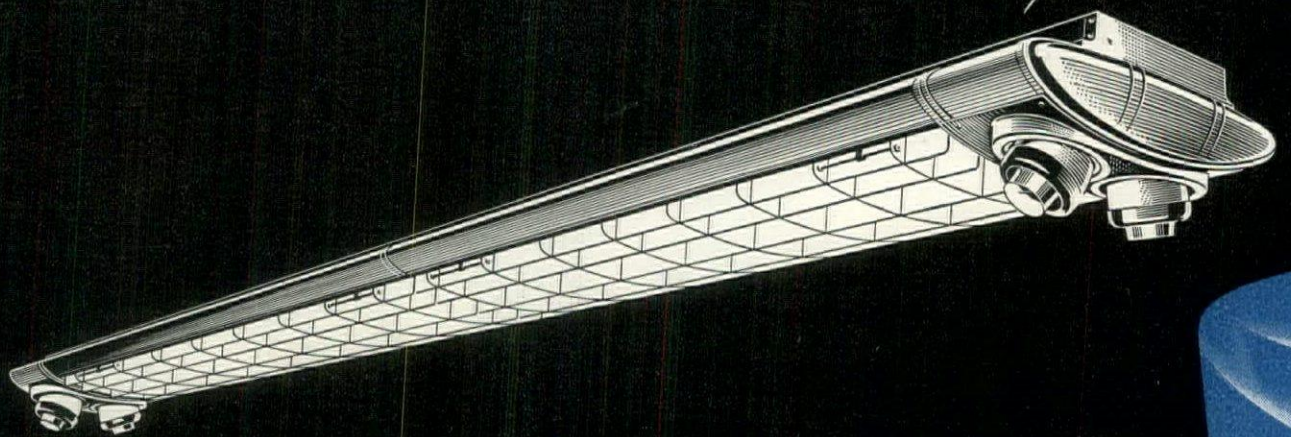

**THE NEW SLIMLINE "MERCHANTISER"
FOR YOUR STORE CUSTOMERS**

YOU CAN BE SURE ...

IF IT'S

Westinghouse

Westinghouse
PLANTS IN 25 CITIES... OFFICES EVERYWHERE

Your store customers recognize the need for uninterrupted lines of illumination over the merchandise areas of their stores. The new Slimline "Merchandiser" answers this need. It provides efficient general-area lighting combined with spotlights to attract attention to special counter and floor displays.

The new "Merchandiser" meets the demand for lighting that starts instantly ... never blinks ... and provides high intensity illumination at lower cost.

Westinghouse now offers you a complete line with the Slimline "Merchandiser" and its three companion units: CS-80, CS-160 and CS-170. They are all *available now* to help your customers improve store appearance

... have better lighting on the merchandise ... increase sales and profits.

Recommend the distinctive "Merchandisers" to your store customers. A Westinghouse Lighting Engineer will gladly co-operate with you, your local Power Company and Electrical Contractor on store lighting problems ... call your Westinghouse Distributor today. Ask for the new booklet, B-4076, "*Smart Selling Begins with Planned Lighting*" or write Westinghouse Electric Corp., P. O. Box 868, Pittsburgh 30, Penna.

J-04198-A

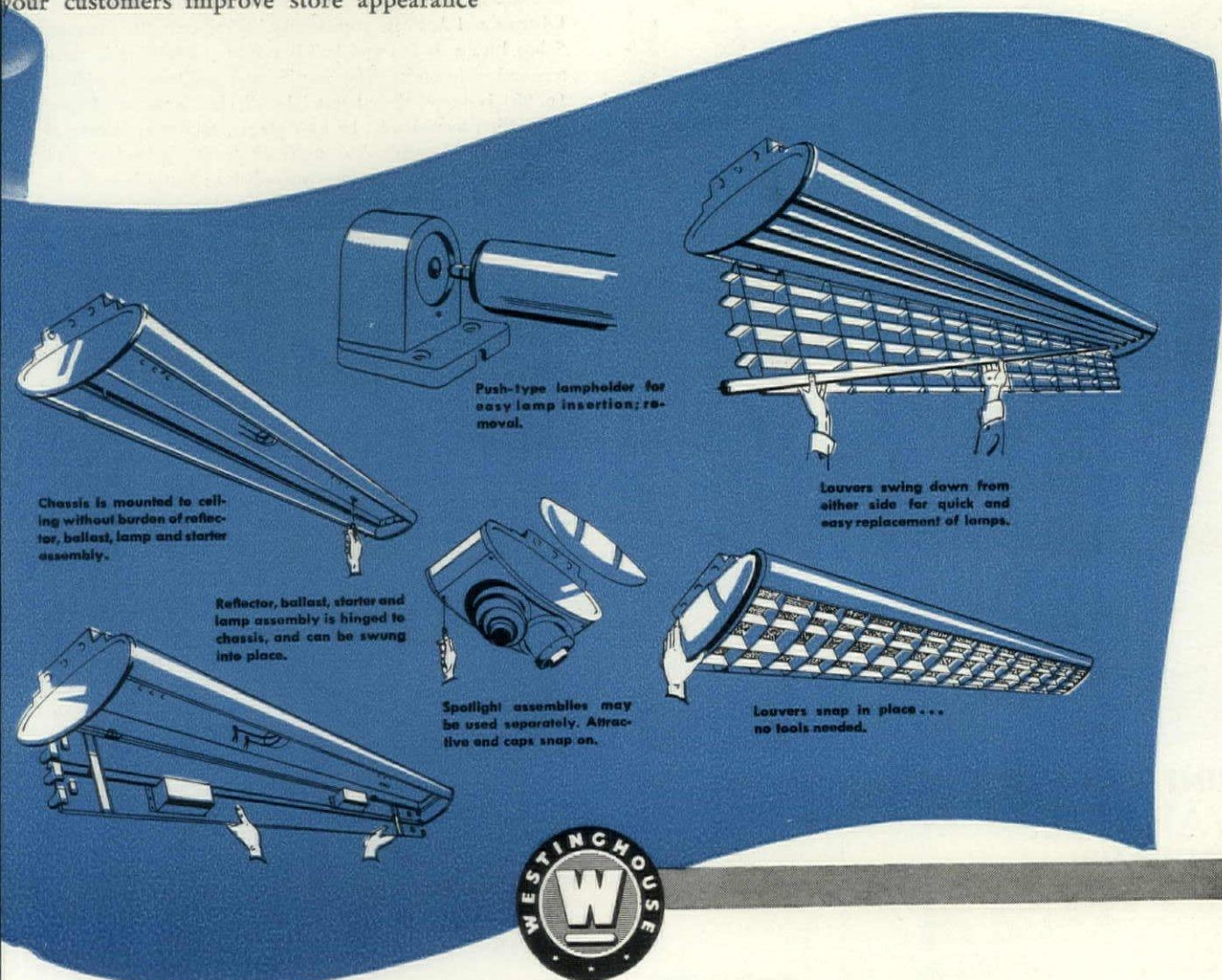

Chassis is mounted to ceiling without burden of reflector, ballast, lamp and starter assembly.

Reflector, ballast, starter and lamp assembly is hinged to chassis, and can be swung into place.

Push-type lampholder for easy lamp insertion; removal.

Louvers swing down from either side for quick and easy replacement of lamps.

Spotlight assemblies may be used separately. Attractive and caps snap on.

Louvers snap in place ... no tools needed.



Planned Lighting Pays

COMMERCIAL • INDUSTRIAL • FLOOD • STREET • AVIATION

Behind the scenes with FORUM contributors

Just off the Press

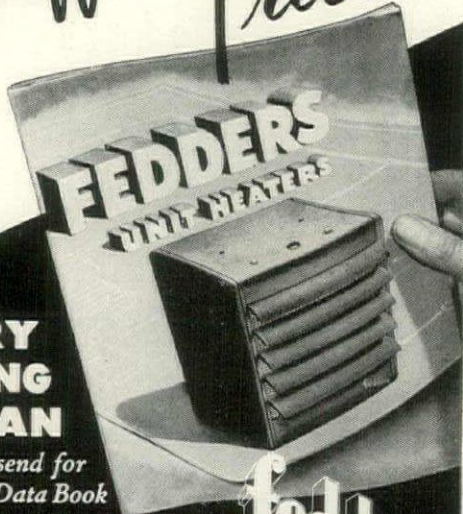

EVERY HEATING MAN
is invited to send for this *Helpful Data Book*

Steam and hot water capacities, heater location, wiring and piping diagrams, throw distances, and heat transmission coefficients put essential data at your finger tips. Write for your copy.

FEDDERS
Series 15
UNIT HEATERS

FEDDERS-QUIGAN CORPORATION
BUFFALO 7, N. Y.



STEEL BLUEPRINT CABINETS NOW AVAILABLE!

- 3-SECTION CABINET (CAP, UNIT AND BASE)
 1. CAP—Interlocking Cover.
 2. UNIT—Five drawers operating on rollers, each drawer equipped with paper depressor on front and protecting hood on back to prevent sheets from curling. Drawers will not pull out accidentally but may be completely and easily removed when desired.
 3. BASE—Interlocking Base—6 inch flush.
- Made of Heavy Gauge Steel with Welded Corners and Seams for Extra Strength and Rigidity.
- Grade "A" Cabinet.

INSIDE DRAWER SIZE	5-DRAWER UNIT 17" HIGH	BASE 1" HIGH	CAP 6" HIGH
37" x 26" x 2"	\$ 93.00	\$11.00	\$13.00
43" x 32" x 2"	\$105.00	\$12.50	\$15.00
50" x 38" x 2"	\$132.00	\$15.50	\$18.50

Prices F.O.B. New York—No charge for Crating. Only one Base and one Cap necessary, regardless of the number of Units to be stacked.

DIV-RACK CORP., Dept. 10AF

66 W. 53rd St., New York 19, N. Y. PLaza 9-7180



HARRIS ARMSTRONG, architect for American Stove Co.'s new administration building in St. Louis (p. 69), is best known for the charming homes he has designed throughout the midwest during the past 20 years. Less publicized are a number of physicians' buildings; furniture and industrial design incidental to his own work; jobs as consultant architect to a large metropolitan department store and several manufacturers. A native of Illinois educated at Washington University and Ohio State, he settled in Kirkwood, Mo. after working for Raymond Hood in New York City.



JEAN MURRAY BANGS is the author of the Greene & Greene story (p. 80) which surveys the career of two almost forgotten architects: designers whose brilliant structural use of wood, starting in 1894, has been a powerful though uncredited influence on American craft building ever since. Miss Bangs, who has done free lance writing in New York City and social work in California, is an economics major with a particular interest in "women in industry." Her current enthusiasm is architectural development in the U. S. In private life she is Mrs. Harwell Hamilton Harris.



GEORGE BECKER, Minneapolis architect, joined with Boe B. Edstrom and A. F. R. Svensson in 1945 to form the company Sebco Inc., a design and building firm specializing in theaters and night clubs. The Star Theater in Clara City, Minn. (p. 95) is one of their latest jobs. Becker, a native of New York City, moved west by easy stages, taking architectural training at Chicago's Armour Institute of Technology and arriving in Minneapolis some years before World War II. In the present partnership he handles architecture; Svensson interior decoration; Edstrom, general building operations.



SHARP & THOMPSON, BERWICK, PRATT, designers of the cliff house (p. 96), is one of the largest architectural firms in Vancouver. G. L. Sharp (not shown and now retired) founded the practice with C. J. Thompson (center) in 1908. Both were educated in England. R. A. D. Berwick (right) and C. E. Pratt (left), both graduates of the University of Toronto, worked with the original firm of Sharp & Thompson until joining the R.C.A.F. in World War II; returned after the war as partners.



TWITCHELL & RUDOLPH, architects of the Revere-FORUM sponsored house (p. 101) are a talented team responsible for much of the best contemporary design to be found in Florida. Ralph S. Twitchell (left) set up his tropical practice after a career including study at Rollins College, McGill and Columbia University; work in New York City with Carrère & Hastings and Raymond Hood; private practice throughout New England; a stint as test pilot of broken down Newport in World War I. Paul M. Rudolph (right) graduated from Alabama Polytechnic Institute into the Twitchell office, became a partner after study under Walter Gropius at Harvard and a wartime Navy career. In 1939 he won the Rorimer Prize.



JOHN E. LAMBIE, JR. is president of Lamolithic Industries, the Florida firm which has developed a high-speed system of concrete field fabrication insuring summer coolness and a bone-dry, mildew-free structure in all weathers. His company cooperated with architects Twitchell & Rudolph in building the Revere-FORUM house (above). Lambie was born in Hong Kong in 1899, educated at England's Rugby School and America's Stanford University, studied law at Middle Temple, London. His father originated the lamolithic construction which Lambie, Jr. has perfected.

BRIXMENT MAKES GOOD

WORKMANSHIP EASIER!



When a nail or line pin is used, the hole should be plugged with mortar as soon as the nail is removed.

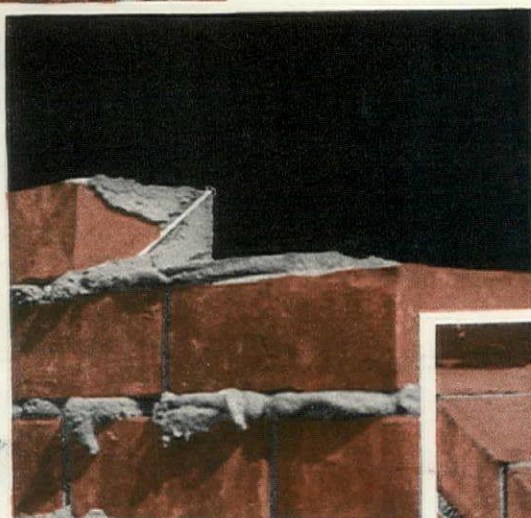

Nail holes frequently connect with voids in the head joints which in turn connect with unfilled furrows in the bed joint.



Water entering through the nail holes may travel through connecting voids and find an opening to the inside of the building.

Twenty years of research by many unbiased engineers have proved that "empty" joints are the chief cause of leakage in brickwork.

Brixment mortar is so unusually rich and plastic that any bricklayer can easily deliver *full joints*. With Brixment mortar there is far less temptation to do the "spot and dab" kind of brickwork which is most vulnerable to leakage.

In addition to extreme plasticity, Brixment has higher water-retaining capacity, better bond-

Nail holes are a frequent cause of leaks in masonry walls. If these holes happen to connect with voids in the head joints, water may enter, and then travel through connecting voids in the bed joint until it finds an outlet on the inside of the wall. *When a nail or line pin is used, the hole should be plugged with mortar immediately after the nail is removed.*

ing quality and greater durability under repeated freezing and thawing. It is this *combination* of advantages that has made Brixment the largest-selling masonry cement on the market.

LOUISVILLE CEMENT COMPANY, Incorporated, LOUISVILLE, KENTUCKY

The Perfect Shower Combination

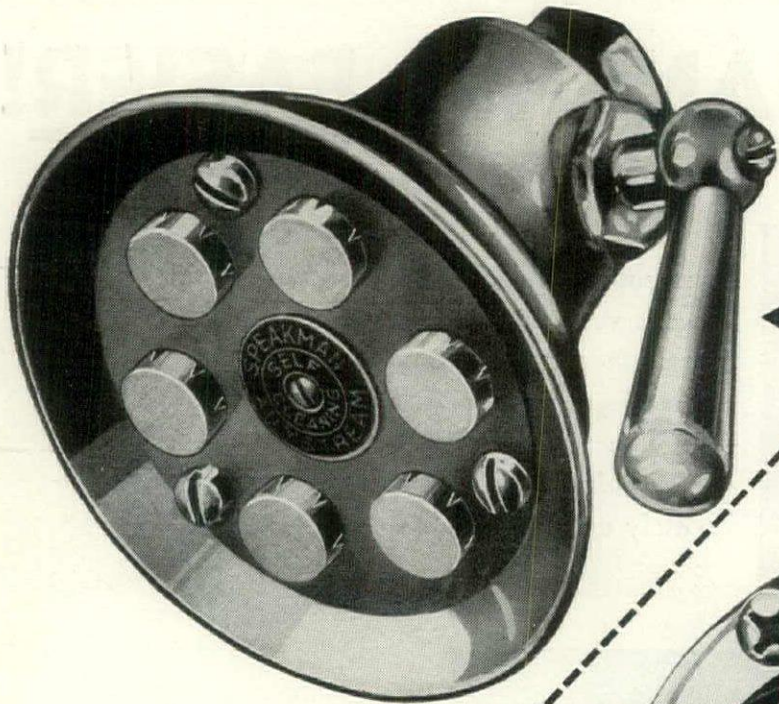

Anystream
Shower Head

Sentinel
Balanced Valve
(CONCEALED OR EXPOSED)

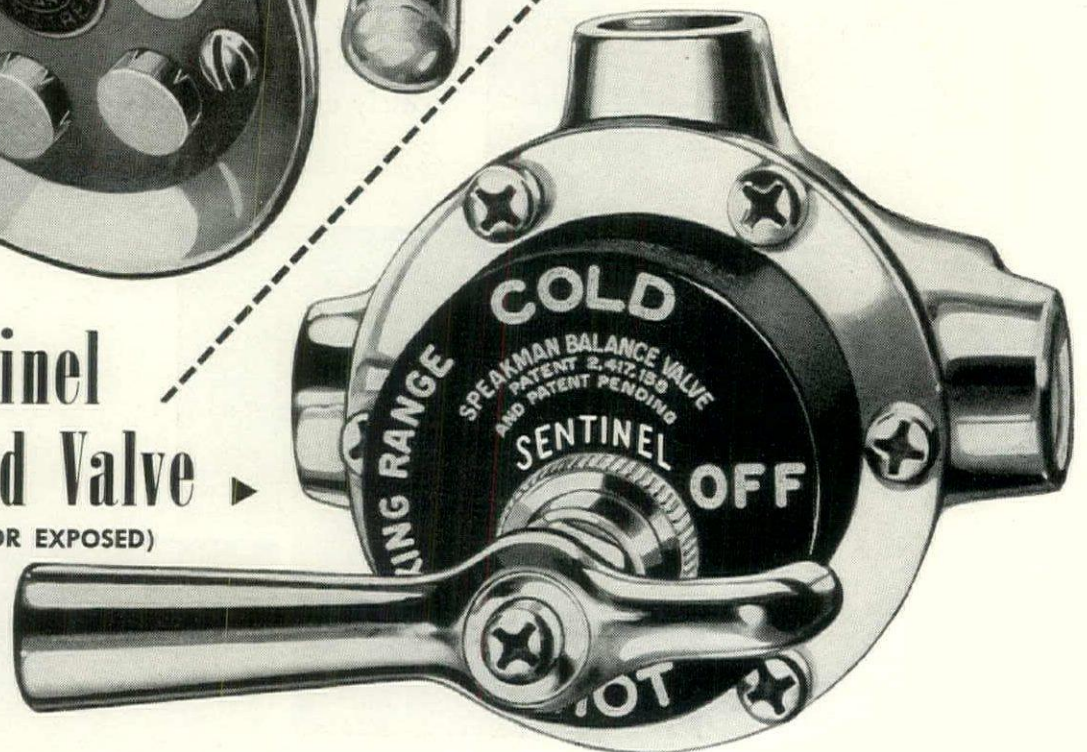

Renovating old showers? Making new installations? Then you'll want to investigate this new Speakman combination . . . the last word in shower development.

The *Anystream Shower Head* gives the bather the kind of shower he likes best. A flick of the lever and you have tingling needles or gentle Spring rain . . . or anywhere in-between! In addition to the adjustable spray, Anystream offers these additional features: *self-cleaning* in the flood spray position, *water savings* up to 58%, and ease of installation.

The *Sentinel Balanced Pressure Shower Mixing Valve* ends the danger and annoyance of abrupt

changes in water temperature due to "down-the-line" water stealing. The bather sets the temperature where he likes it . . . and the temperature stays there! The Sentinel Valve's temperature control is achieved without thermostats, rockers, or other gadgets likely to get out of order! It's all done with a miraculous f-l-o-a-t-i-n-g Sentinel piston that automatically balances and compensates for water pressure variations.

The *Anystream* and *Sentinel* shower combination is ideal for any kind of shower installation . . . in homes, apartments, hotels, schools, institutions. Send for free literature describing these remarkable shower fixtures.

See *Sweet's Architectural File*
for a condensed catalog of
Speakman Showers and Fixtures

"Established in 1869"
SPEAKMAN

SHOWERS AND FIXTURES

SPEAKMAN COMPANY, WILMINGTON 99, DELAWARE

Leader

NEW HORIZON *Slimline-Lamp* Fluorescent Fixture

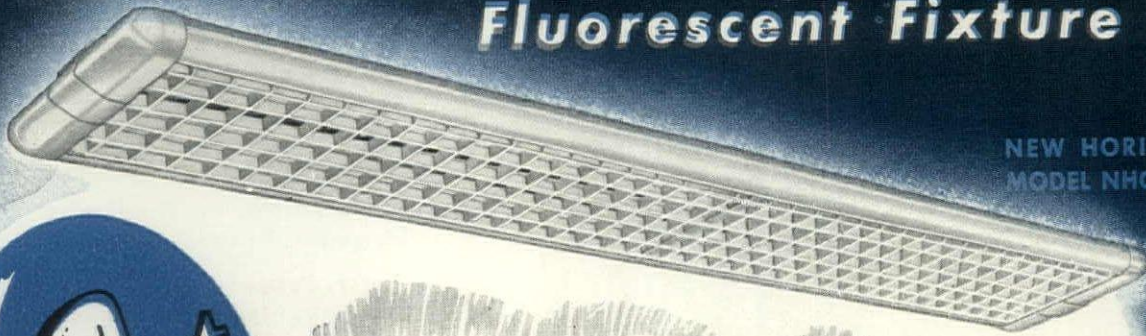

NEW HORIZON
MODEL NHC-480

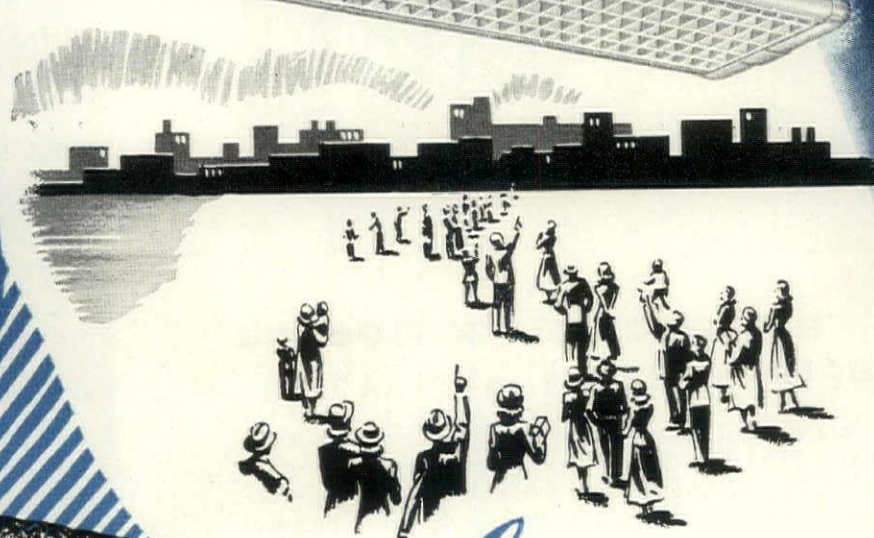

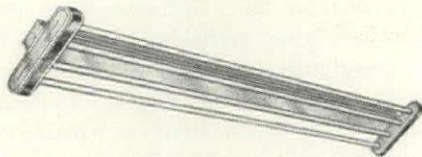

Another *Leader First!*

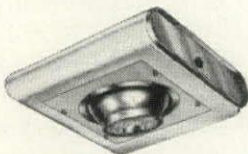

Leader NEW HORIZON Open Type Fixture, especially designed for mass lighting of large commercial establishments.



The NEW HORIZON Incandescent Spotlight. Excellent for highlighting displays. Available for corner or center installations.

-  **FIRST** successfully-engineered, fully-proven, Slimline-tube lighting fixture.
-  **FIRST** on the drafting board; first into production; first into the testing laboratory; and first on the market!
-  **FIRST** in a beautiful fixture ensemble of gleaming metal and plastic. First to achieve this practical result: Maximum diffusion of horizontally-directed light; muffled glare with a minimum of light interference.

NEW HORIZON, Model NHC-480 (as illustrated above) has drawn aluminum end-caps. Newly-designed, destaticized moulded-PLASTIC lightweight louvers (will not warp or discolor). Fully guaranteed. New-style tubular-PLASTIC translucent side panels . . . Slimline (instant-start) tubes designed for *four* eight-foot tubes; F96-T-8. Also for *two* eight-foot tubes; NHC-280.

Ask for complete mechanical details



LEADER ELECTRIC COMPANY

3500 NORTH KEDZIE AVE. • CHICAGO 18, ILLINOIS
WEST COAST FACTORY • 2040 LIVINGSTON • OAKLAND 6, CALIFORNIA

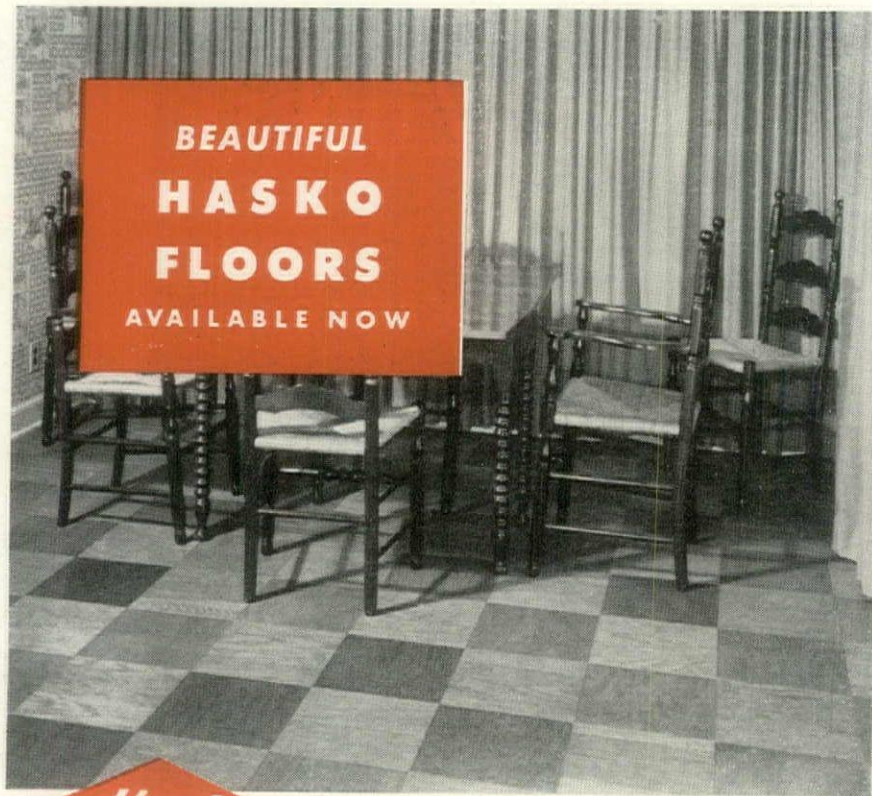

**BEAUTIFUL
HASKO
FLOORS
AVAILABLE NOW**



HARDWOOD BLOCK FLOORING HAS NEW CUSTOMER - APPEAL

The luxurious beauty and unusual construction and sales advantages found only in Hasko Interlocking Block Flooring are equally important to the architect and builder. Here is a Block Flooring that provides a unique, long wearing, and distinctive floor pattern of beautiful northern oak, yet is practical to install and use . . . that is equally adaptable to new or old homes and buildings. There is a substantial saving in time, materials and labor with Hasko Floor Blocks. Pre-cut, pre-finished, they require a minimum of sawing and fitting, and are ready for instant use upon laying. 12"x 12" Hasko Blocks, 3/4" thick, are built up of multiple plies of veneer, permanently bonded and cross grained, assuring floor flatness and great durability.

INTEGRAL INTERLOCKING TONGUE AND GROOVE

The tongue and groove are integral parts of every Hasko Block. They interlock each block with those surrounding it to create an extra margin of assurance that the whole floor will always remain flat.



EASY TO INSTALL

Hasko Blocks can be installed with mastic directly over concrete without the use of screeds, lag screws or expansion bolts or by nailing over wood, sub-floors or old floors.



Write today for your copy of this new Haskelite Bulletin explaining in detail the design and construction advantages of Hasko Block Flooring.



ADVERTISED IN LEADING NATIONAL MAGAZINES

HASKELITE MANUFACTURING CORP., DEPT. AF, GRAND RAPIDS 2, MICH.

New York Chicago Detroit Boston St. Louis Philadelphia Los Angeles
CANADA: Railway & Power Engineering Corporation, Ltd.

THE PEOPLE'S ART CENTER (sponsored by the New York Museum of Modern Art; Victor D'Amico, Director) aims to bring art appreciation and techniques within reach of art lovers of all ages and backgrounds. Children from three years upwards, boys with a pronounced mechanical bent, adults with previous training and those whose interests are still in a nebulous stage—all are provided for in the more than 50 groups listed in the center's first prospectus. Special courses like "Arts in Therapy," "Techniques in Teaching Art" and "Understanding Your Child through Art" supplement full programs in painting, life sketching, ceramics, industrial and interior design, jewelry making and woodworking. The fee for most adult courses (including materials) is \$40; children's groups range from \$27.50 to \$37.50.

EGMONT ARENS, industrial designer is presenting 15 weekly lectures, September 29 - January 19 on "The Industrial Designer & Merchandising; Product and Package Design."

FORESTS PRODUCTS RESEARCH SOCIETY CONVENTION (North East Section) October 21-22, Hotel Pennsylvania, New York 17 N. Y.

SCHOOL BUILDING PREVIEWS

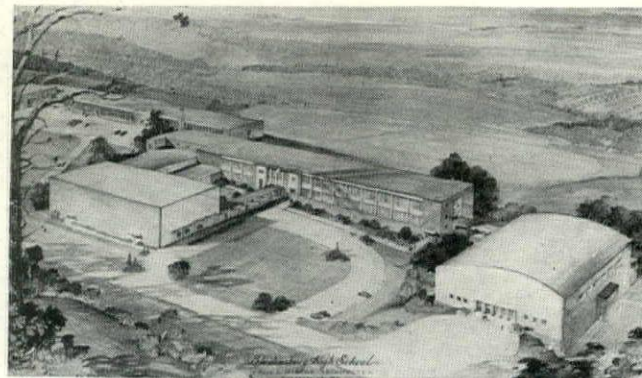

A VOCATIONAL SHOP BUILDING (left background of the sketch above) is the first unit of Washington, D.C.'s Bladensburg High School to get underway. The full \$2,000,000 necessary to provide for the neighborhood's 1,500 students of high school age is not available at this time, but the community has farsightedly commissioned Architects Ross & Walton to plan the complete building group. Problems of future expansion have been kept as simple as possible by basing on a 16 ft. module not only structural members, but heating, ventilating and lighting equipment as well. The Vocational Building (cost \$320,000 or 72¢ per cu. ft.) will house ten workshops with all facilities for classes in auto repairing, printing, welding and metal work, carpentry, refrigeration, air conditioning, electrical work, radio and television. Its steel frame is enclosed by exterior brick facing and interior walls of cinder block; floors are of heavy duty ground concrete, and the roof and ceiling is formed of wood fiber structural slabs which also provide acoustical treatment.

Future buildings (gymnasium, lower right of sketch; classrooms, center; auditorium, lower left) will be of reinforced concrete with precast concrete panels for covering and exterior formwork. A community library and cafeteria round out the services of the completed project. The central colonnade will do double duty as a covered passage between the auditorium and the classroom unit and a bus-loading shelter in bad weather. Consultants were H. W. Redmile & Associates, mechanical engineers and Faisant & Kookken, electrical engineers.

(Continued on page 52)

WITH PITTSBURGH COLOR DYNAMICS

you can use the energy in color to make office quarters more attractive and increase efficiency of workers.



What **COLOR** will do for your building!

COLOR used for decorative purposes in office buildings has taken on added significance. Tests have shown that some colors stimulate, others relax, still others depress even causing discomfort and fatigue.

Pittsburgh technicians and color experts have long been studying, testing and proving the effect of this *energy in color* upon human beings. From their research were derived the principles of the new painting system of **COLOR DYNAMICS**.

With **COLOR DYNAMICS**, you can specify attractive color arrangements that will retard eye fatigue of workers, increase their efficiency, improve their morale and reduce the hazard of accidents.

Rooms can be made to seem more inviting and spacious, longer or wider, higher or lower. Halls and stairways can be made brighter and safer. Lobbies and reception rooms can be made to reflect more accurately the spirit and character of the organizations that use them.

You can apply the principles of the *energy in color* with scientific accuracy. What you can do with **COLOR DYNAMICS**—and why—is told in our profusely illustrated booklet. It also contains many practical suggestions for the decoration of lobbies, stairways, corridor as well as private and general offices.

Send this coupon for your *free* copy of this booklet.

Paint **RIGHT** with **COLOR DYNAMICS** Paint **BEST** with Pittsburgh Paints!

The benefits of **COLOR DYNAMICS** are made extra long-lasting when you use Pittsburgh high-quality paints. There's a **PITTSBURGH PAINT** for every need!

WALLHIDE—in three types: **PBX**, extra-durable; **SEMI-GLOSS**, for higher sheen; **FLAT**, for velvet-like finish.

WATERSPAR ENAMEL—for furniture, woodwork and metal trim.

FLORHIDE—for floor surfaces; can be scrubbed repeatedly with soap solutions.

Pittsburgh Plate Glass Co., Paint Div.
Dept. AF-108, Pittsburgh 22, Pa.

Please send me **FREE** copy of your booklet on **COLOR DYNAMICS**.

Name _____

Street _____

City _____

State _____

FREE BOOKLET! ➔

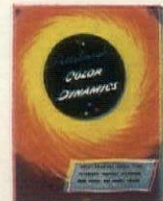

PITTSBURGH PAINTS
PAINTS • GLASS • CHEMICALS • BRUSHES • PLASTICS

PITTSBURGH PLATE GLASS COMPANY

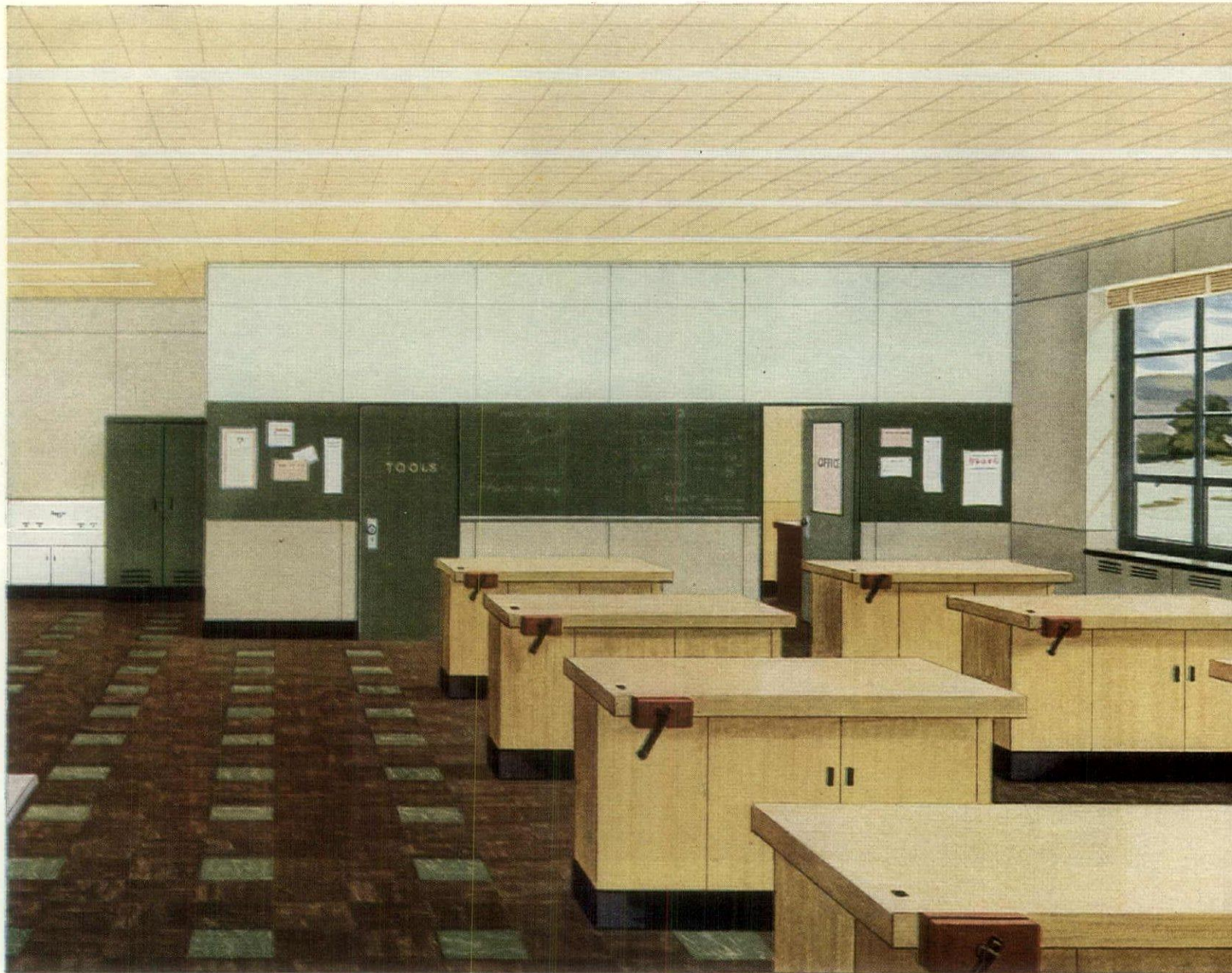

**Use all 3 products—Walls, Ceilings, Floors—
for Johns-Manville Unit Construction . . .**

With this new method of interior construction, you can meet the problem of ever-changing space needs.

You can provide for endless revisions of space-use—at low cost. You can keep expanding, converting, or subdividing rooms as often as conditions require . . . with little or no interruption to routine activities!

Moreover, the J-M Unit Construction system now makes

the *complete interior* available under *one* specification, *one* manufacturer's responsibility.

Three Johns-Manville materials, described at right, are the basis of this revolutionary development. The asbestos Transite Walls are *movable*, 100% salvageable. The Acoustical Ceiling Units are *demountable* . . . can readily be taken down and re-located as desired. And the Asphalt Tile Floors consist of small units which permit easy extension of the floor to meet changing conditions.

Write for colorful brochure, giving full details on the remarkable *flexibility* of J-M Unit Construction.

. . . for Offices



. . . for University Lecture Rooms



. . . for Laboratories



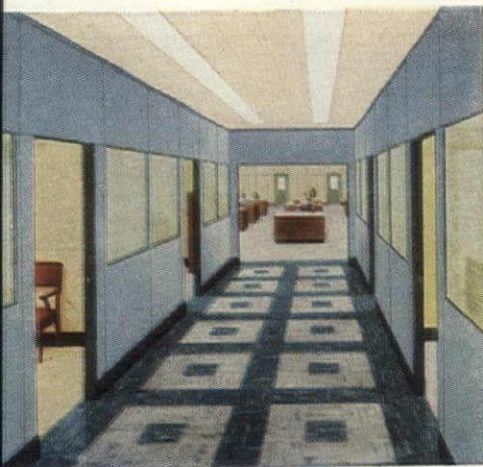

... for Institutions and Hospitals

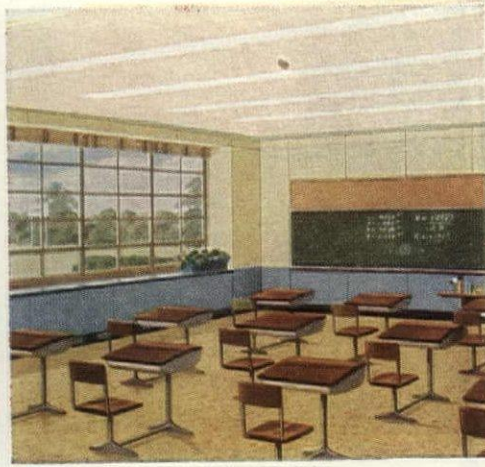

... for Schools

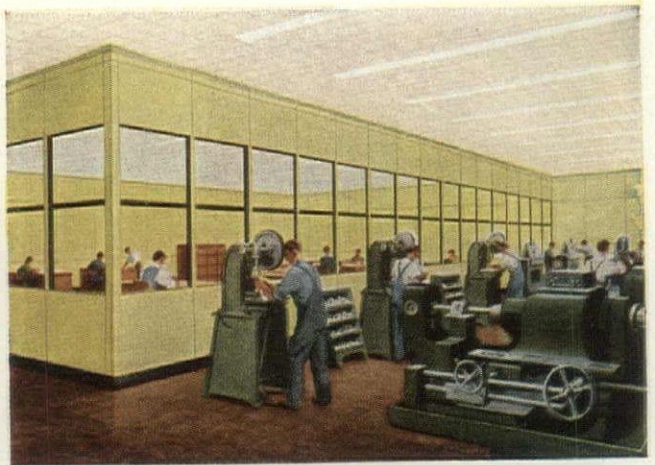

... for Factory Areas

Interiors today that provide for tomorrow!



1. TRANSITE WALLS—Movable!

Rooms when and where you want them . . . that's the magic of Johns-Manville Transite Walls—the attractive and sturdy asbestos walls that are *movable*. Now you'll never again need to send partition walls to the dump every time space changes are required!

With the least inconvenience—almost *overnight*—you can enlarge, decrease, or rearrange areas as often

as your needs require. Transite movable panels are easy to handle, readily assembled, interchangeable, and can be used over and over again. Made of asbestos and cement, Transite Walls have all the qualities of solid and permanent construction. They provide rigid, double-faced partitions, and can also be used as the interior finish of outside walls.

To make sure your interiors will provide for *change*, write for booklet, "J-M Transite Movable Walls."



2. ACOUSTICAL CEILINGS—Quieter!

There's a Johns-Manville acoustical material to give you the best in sound control, no matter what the type of interior.

To assure you the maximum in noise-quieting, Johns-Manville not only provides the correct acoustical materials for each specific condition, but follows through by *installing* the materials *properly* with its own con-

struction crews. In other words, you get "J-M materials installed by Johns-Manville" for best results.

That's the all-inclusive service . . . the *undivided responsibility* Johns-Manville gives your projects.

For further details, send for brochure, "J-M Sound Control." Describes such J-M acoustical products as demountable Sanacoustic, Fibracoustic and Fibretone, Transite Acoustical Panels, and special materials for Broadcasting Studios.



3. ASPHALT TILE FLOORS—Colorful!

You spend no more to have *quality* floors like these—attractive and resilient . . . extra-long wearing . . . reinforced with indestructible asbestos!

That's the kind of flooring you get with Johns-Manville Asphalt Tile. It's easy on the eyes, easy on the feet, and easy on the budget, too.

Yes, you'll like *everything* about this modern floor-

ing, including the unlimited range of color combinations—from striking patterns with strong contrasts to solid fields of marbled colors.

J-M Asphalt Tile does not originate dust . . . stays fresh and unmarred with practically no maintenance. Individual units permit easy repairs.

For areas exposed to oil or grease, use J-M *Grease-proof* Asphalt Tile. Send for full-color brochure, "Ideas for Decorative Floors."

... for Reception Lobbies and Stores

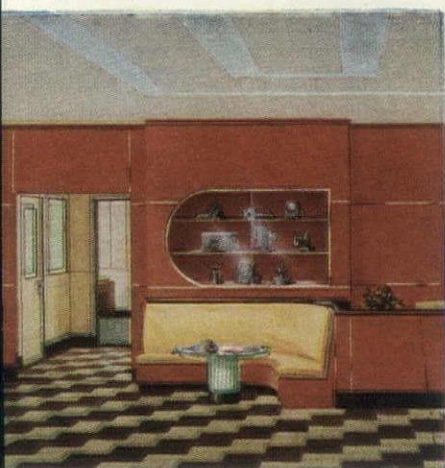

Production of Johns-Manville Building Materials has now been greatly increased to meet unprecedented demands. So the chances are better than ever that you can get the materials you want when you want them. Write Johns-Manville, Box 290, New York 16, N. Y.



Johns-Manville Walls - Ceilings - Floors

ARCHITECTS ARE SAYING:



"MORE AND MORE
OF MY CLIENTS
ARE NOW DEMANDING

Forced Warm
Air Heating"



Yes! HERE'S WHY....

Today... everyone is comfort minded. The buying public knows that to install only a heating plant in a new building is to leave the job half done.

The American inventive mind, directed toward indoor comfort has settled upon forced warm air heating for domestic, commercial and industrial buildings as the medium best suited to bring about these health and comfort extras now deemed essential:

1. Filtered air... for cleaner, healthier indoor living and working.
2. Proper humidity... to eliminate "Sahara" de-hydration.
3. Even heat distribution... thru modern engineering rather than haphazard natural convection.
4. Summer air-conditioning... without expensive auxiliary systems.
5. Continuous air circulation... air changes in building 6 times per hour with re-filtering and re-humidification.

The above health and comfort factors usually cost less than a natural convection system... but today's buyers would willingly pay more to obtain the plus features that forced warm air heating gives.

And that's why most of my building specifications specify forced warm air heating.

.... AMERICA'S LARGEST AND MOST
COMPLETE WARM AIR HEATING LINE

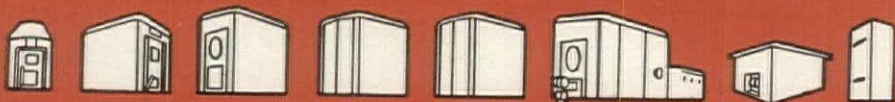

A PRODUCT OF

JACKSON & CHURCH CO., SAGINAW, MICHIGAN

"WORK WELL DONE SINCE '81"

PHILADELPHIA'S \$5,000,000 HIGH SCHOOL for the Mayfair district will serve not only the 4 to 5,000 students its classrooms can accommodate, but the adult recreation needs of surrounding communities. The school is only two stories high and is planned so that light, heat and service can be supplied "sectionally" throughout the building—making each unit inexpensively available for extracurricular purposes. Plans provide for 82 regular classrooms (30 x 24 ft.); a cafe

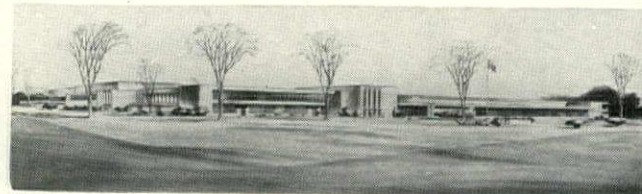

teria equipped to serve 1,500 at one time; a main gymnasium with 2,000 permanent seats and 2,000 movable ones; four smaller gyms for specialized purposes; and an auditorium seating 1,500. Outdoors, the 46-acre tract encloses a full baseball field and football field, 22 tennis courts, several hockey and soccer fields, an outdoor swimming pool and parking space for 500 cars. Construction on the project has already started and should be completed by September 1949. The contract cost, including all facilities, is 89 cents per cu. ft. Simon & Boulware were architects and engineers for the school; John McShain is builder.

"HIDDEN TALENT" COMPETITION

THE MUSEUM OF MODERN ART, New York and the *Architectural Record* magazine are co-sponsors of a contest offering \$2,750 in prizes, open to all architects and designers *except* those whose work has appeared in any national magazine. The best designs submitted for a memorial community center in a typical midwestern town will be exhibited at the Museum and published in the *Record* in February, 1949. The competition closes November 8th.

EXHIBITS

THE ARTS WORK TOGETHER—Architecture, Design, Mosaic, Painting, Sculpture. Artist-collaborations on nine design projects presented through sketches, models and original art works. Designs cover a wide field, including: a fleet of ships, a sanitarium for alcoholics, a swimming pool and recreation area, a fine arts building, a tobacconist shop, a movie theater and several residential units. Architects and designers represented in the show are Henry Dreyfuss, Schweikher & Elting, William Lescaze, Robert W. Kennedy, Reisner & Urbahn, Poehler & Elder, Thomas Church & Lawrence Halprin, and George Rockrise. Mortimer Levitt Gallery, New York, N. Y., September 28-October 30.

BUILDING TODAY—CHURCHES, SCHOOLS and THEATERS, Akron Art Institute, Akron 8, Ohio, Oct. 2-31. Photographs, plans and models of contemporary building.

RARE ARCHITECTURAL BOOKS. Original editions of historic architectural texts. Avery Architectural Library, Columbia University, New York, N. Y. Through October 15.

EXHIBIT OF MEMBERS' SUMMER WORK. Presentations of house plans, landscaping, interior design and decoration. Architectural League, New York, N. Y., October 17-29.

SEEING MODERN ART. Photographs, paintings, lectures on interpretation of modern art. Newark Museum, Newark, N. J. Beginning October 15.

(Continued on page 54)

The
Sign
of the
times

is

**“CERTIFIED
ADEQUATE
WIRING”**



“We find that having our houses wired with a good electrical system gives us a distinct selling advantage. The certificate furnished is self-explanatory and builds customer confidence. The Adequate Wiring program is a real asset to the new homes market,” says Mr. M. H. Karnes, Sr., St. Petersburg, Fla. builder.

Proof Adequate—

another home-building project featuring **Certified Adequate Wiring**—by Karnes & Karnes, Inc., St. Petersburg, Fla.

What It Means To You: Certified Adequate Wiring makes today’s home buyers tomorrow’s boosters. It helps you build houses that stay modern for years. It helps you sell houses easier and quicker because: (1) it overcomes today’s buyer resistance; (2) it assures promotional support from your electrical industry.

What It Means To The Home Buyer: Adequate Wiring makes even a moderate-cost house, or a remodeled home, *modern*. It provides not only for today’s electrical needs but for those of tomorrow—including such things as kitchen and laundry appliances which can be covered by a “packaged mortgage.”

What “Adequate Wiring” Means: An adequate electric service entrance; enough circuits; enough convenience outlets; permanent lights and switches.

Here’s What You Can Do About It:

1. Use the services of your local Adequate Wiring Bureau in preparing complete wiring layout for every floor plan.
2. Install Adequate Wiring in accordance with this layout.
3. Obtain your “Proof Adequate”—a certificate for each deed.
4. If there is no Adequate Wiring Bureau in your area, *write us* for details of how to use “Adequate Wiring” as a sales feature.

**NATIONAL
adequate wiring
BUREAU**

CLIP AND MAIL TODAY for free information and material!

NATIONAL ADEQUATE WIRING BUREAU, Dept. AF-10
155 E. 44th Street, New York 17, N. Y.

Please send me, without charge, information on how to take advantage of Adequate Wiring as a sales feature.

NAME.....
TITLE.....
STREET ADDRESS.....
CITY..... STATE.....

ANNOUNCEMENTS

SAVED by a PENCIL STROKE!

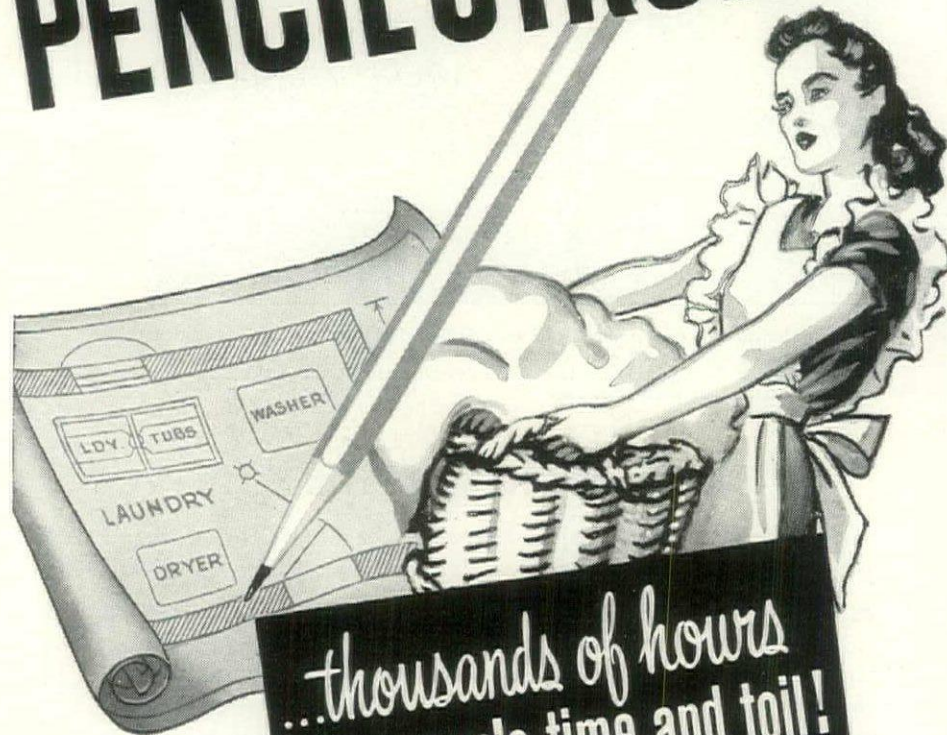

...thousands of hours of women's time and toil!

6 square feet of laundry room space



Lugging heavy laundry baskets out to a backyard clothesline — women worrying themselves sick over bad wash-day weather — frustrated by sooty, dirt-laden air — that's the toughest remaining task of home laundering!

That's why women everywhere want the permanent washday relief of a Hamilton Automatic Clothes Dryer. Today's desires become tomorrow's demands. They'll bless you for your thoughtfulness in providing space in your plans for the Hamilton they're bound to buy eventually!

Just think — one stroke of your all-powerful pencil and your good deed's done . . . well, maybe a dozen strokes . . . anyway, it's no great problem. Just 6 square feet in a sensible spot, near the gas line or 220-volt current outlet. (You'll gain ten times that because you needn't provide for basement clotheslines!)

ELECTRIC AND GAS MODELS
finished in high-lustre white baked enamel. Width 31", depth 27½", height 39", weight 268 pounds.

In Canada the Hamilton Dryer is known as the Coffield-Hamilton Automatic Clothes Dryer, and is distributed by the Coffield Washer Company, Hamilton, Ontario.

Hamilton AUTOMATIC CLOTHES DRYER

HAMILTON MANUFACTURING COMPANY
Two Rivers, Wis.

WORLD'S LARGEST MANUFACTURER OF EQUIPMENT FOR THE PROFESSIONS

ROBSJOHN-GIBBINGS AND THE TALL BAMBOO

Maynard Parker



The light, sinuous pieces and sparsely luxurious exhibition rooms that T. H. Robsjohn-Gibbings has designed for Widdicombe Furniture Co., Grand Rapids, Mich., are particularly adapted for the mild Pacific Coast climate—although radiant heating makes this type of furnishing practical for a wider area. It was with the sub-tropical locale in mind that Robsjohn-Gibbings chose as his decoration motif the tall California bamboo; and he uses this theme not only for the shape of furniture members but for the patterns of specially designed textiles and screens. All actual woodwork, however—including the large over-mantel panel above—is of walnut.



Most graceful among the new pieces is a lounge chair which provides comfortable seating, either combined with a foot rest or without it; either with arms (upper picture) or without them (lower). Several wooden chests and cases and an upholstered section sofa have also been added to the Robsjohn-Gibbings group. His contribution to the living-dining room is the suggested use of a long wall-backed settee with a "butterfly" table. Table and settee heights are coordinated for comfortable dining-sitting while by an asymmetric leg arrangement the table can be moved close enough to the settee for easy service.

(Continued on page 56)



When is a modern kitchen REALLY modern?

WHEN it's equipped with refrigeration, automatic dishwasher, garbage disposal, automatic range, cabinets from here to there—and *one thing more:*

Complete, quiet, efficient ventilation! And THAT means a G-E kitchen ventilating fan!

Such a fan makes your homes *far more* attractive to women prospects! They know the kitchen will be *cool*. No steam. No smoke. No grease. No cooking odors.

They know paint, woodwork, and wallpaper will stay fresh longer. They realize *instantly* that such a fan makes a kitchen a pleasant, *modern* place to

work. BUT—

Be sure that the kitchen fans you install in your houses are *General Electric Ventilating Fans!* Common sense dictates it.

Years of experience!

General Electric pioneered the electric fan. We've been making them for 58 years... and many G-E Fans have been in operation over 20 years.

We believe we make a better-quality fan! (For one thing, the heart of our ventilating fans is the famous General Electric motor.)

A BIG PLUS

G-E Fans are *automatic* in operation. Flip a switch—outside cabinet door opens—blades begin their quiet spinning. Flip a switch again—fan stops—outside door shuts. And they're *easy* to install. (One more reason why they're tops with builders.)

NOTE—G-E Ventilating Fans completely and quietly renew the air in an average-size kitchen several times an hour! What a "selling plus" for you! Appliance and Merchandise Department, General Electric Company, Bridgeport 2, Conn.

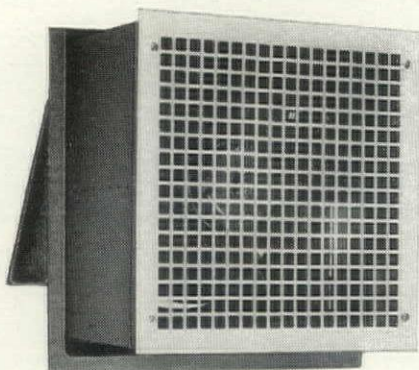

INSIDE

G-E Ventilating Fan:
Provides fresh air—*quietly without drafts*—in kitchens and other rooms where heat, smoke, grease, and odors are likely to accumulate... ideal for laundries.

Wall switch controls fan. Outside door opens *automatically* when fan is ON; shuts when fan is OFF! *Easily installed*—adjustable wall box fits walls from 5½ to 11 inches thick. Needs only 12¾ inches square opening in wall. 110/120 volts, 60 cycles. Model FM10CL.

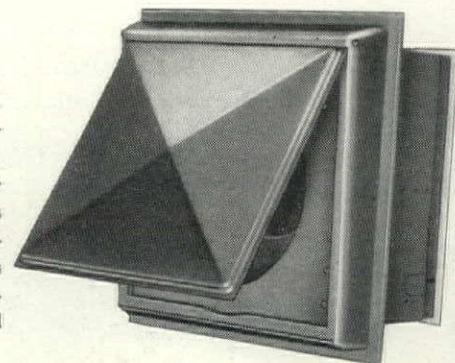

OUTSIDE

GENERAL  ELECTRIC

ANNOUNCEMENTS

URBANE INTERIORS

Ben Schnall

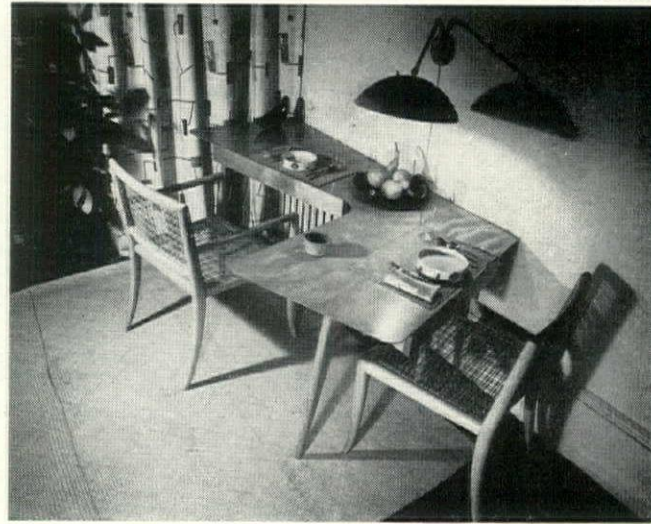

Skillful design of furniture and draperies make the new Edith Hernandez decorating shop, 39 E. 35th St., New York City, its owners' best advocate. Given a narrow high-ceilinged room—typical *bête noire* of city decorators—William and Edith Hernandez have turned it into a bright well-spaced office for their design work and for consulting with clients. The irregular-shaped clear birch table (upper picture) serves as a double desk and work table—its unobtrusive drawers now hold drawing tools, would be just as convenient for cutlery if used for dining. The chairs, of bleached oak with cane for seat and back, are strong as well as elegant, with firm jointing to compensate for the absence of all stretchers.



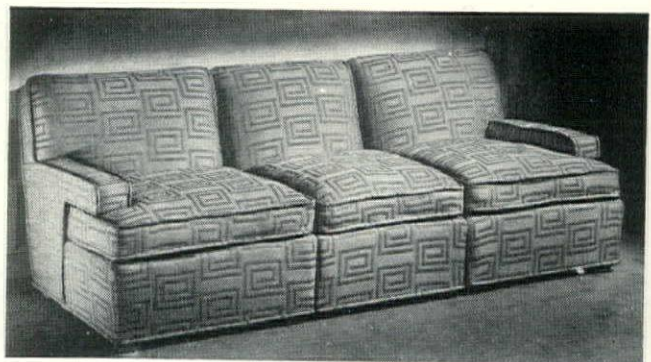

TRADITIONAL MODERN





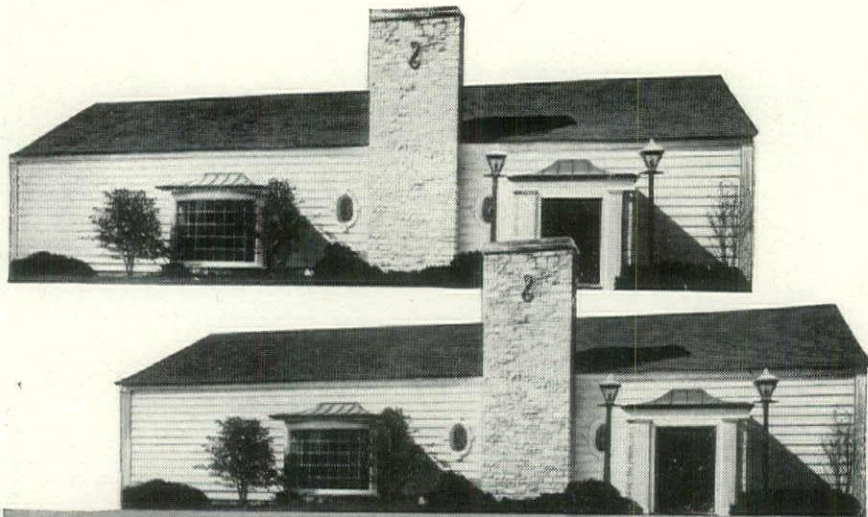

With the "Sophisticate Group," the Mansfield Furniture Co., 208 E. 18th St., New York, N. Y., acknowledges the first inroads of modern on its heretofore traditional preserve. Designed by Edith Chatterton Thomas, these sectional upholstered pieces aim, in their rather heavy regularity, at making the best of two worlds—"to be integrated into traditional as well as contemporary settings."

(Continued on page 58)



Check 
the double
advantages of:



-  Eagle RTU is *pure white lead*. It has all the famed durability, beauty and economy of this most famous of painting materials.
And, Eagle RTU comes factory-mixed for perfect brushing. It goes to the job in the original container, all set to open, stir and apply.
-  Eagle RTU spreads smoothly and easily. It covers completely, leaving no brush-marks, has real white lead hiding and staying power.
And, Eagle RTU makes a smooth, gleaming elastic coat that won't crack or scale . . . defies time and weather, ages evenly by gradual chalking.
-  Eagle RTU is favored by builders for time and labor saving convenience . . . because it enables them to do a *better* job more efficiently.
And, Eagle RTU is preferred by homeowners because of its beauty and durability . . . because of its *whiter* white that stays white *longer*.
-  Eagle RTU is white lead paint in a *modern* form.
And, Eagle RTU is backed by Eagle-Picher's 104-year-old reputation as well as by the 2,000-year-old reputation of white lead.

**EAGLE PURE
WHITE LEAD**
Paint

**EAGLE
EP
PICHER**
Since 1843

THE EAGLE-PICHER COMPANY
CINCINNATI (1), OHIO
Member of the Lead Industries Association



Noon-hour "break" for employees

Cheerful CAFETERIAS of

Facing tile

Yes, it's a good break for employees—for everyone concerned in fact—when you select Structural Clay Facing Tile for any cafeteria interior.

Naturally workers like bright, clean surroundings. That's why cafeterias with colorful, sparkling clean walls of Facing Tile provide an extra-pleasant break in the working day, prove to be a real morale booster.

For you who build or design there are many other advantages. You can get Facing Tile when you want it, glazed or unglazed, in flexible, efficient modular sizes, in a variety of light-reflecting colors. It helps you speed construction, gives you fire-safety, great structural strength and it won't crack, mar or decay.

And the fellow who finally foots the bill...he gets a real break too. Facing Tile gives him a wall and sanitary interior finish in one material, *at one cost*. Maintenance is as easy and inexpensive as soap-and-water cleaning. Facing Tile has a lustrous finish that's impervious, even to bacteria. It needs no redecorating or refinishing, *ever*.

You can get further information in Sweet's, or from your nearest Institute member. He'll be glad to serve you.

WRITE FOR 90-PAGE MODULAR FACING TILE HANDBOOK.

It's *free* to architects and engineers, fifty cents to others. Write Desk AF-10 of the Institute on your letterhead.

FACING TILE INSTITUTE

1756 K STREET, N. W. • WASHINGTON 6, D. C.

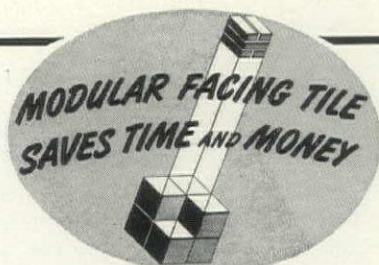

INSTITUTE MEMBERS

- | | |
|--|--|
| Belden Brick Company, Canton, Ohio | Metropolitan Paving Brick Co., Canton, Ohio |
| Continental Clay Products Co., Kittanning, Pennsylvania | National Fireproofing Corp., Pittsburgh 12, Pennsylvania |
| Charleston Clay Products Co., Charleston 22, West Virginia | Stark Brick Company, Canton, Ohio |
| Hanley Company, New York 18, N. Y. | Standard Clay Manufacturing Co., New Brighton, Pa. |
| Hydraulic Press Brick Co., Indianapolis, Indiana | West Virginia Brick Company, Charleston, West Virginia |
| Mapleton Clay Products Co., Canton, Ohio | |

there's a **TRANE** system wherever you look
 ...from **PUMPING STATION**
 to **PALATIAL HOTEL**



The cold water going through this pumping station caused condensation on pipes, which resulted in a humid atmosphere. A Trane System now keeps the air dry, so that water purifying chemicals stay dry, and employees feel better.

INDUSTRIAL HEATING AND AIR CONDITIONING

Large window areas and exhaust fumes from hundreds of cars created a heating and ventilating problem in this huge garage. The owners chose a Trane System that heats the building, counteracts window drafts, and removes exhaust fumes.



COMMERCIAL HEATING AND AIR CONDITIONING



This lovely apartment hotel features a magnificent view of the ocean, but chilly sea breezes caused drafts at the windows. Now, inconspicuous Trane Convector-radiators overcome the drafts and give the occupants ideal heating.

DOMESTIC HEATING AND AIR CONDITIONING

There is a Trane System to solve every kind of heating and air conditioning problem efficiently, whether it be comfort or process—domestic, commercial, or industrial.

Trane Systems are designed to fit your application by architect, engineer, or contractor. 200 Trane Sales Engineers offer their counsel. *Users' names on request.*

TRANE

MANUFACTURING ENGINEERS OF
HEATING and AIR CONDITIONING

THE TRANE COMPANY, LACROSSE, WISCONSIN **systems**
 ALSO, TRANE COMPANY OF CANADA, LTD., TORONTO

ROOMER'S PROGRESS

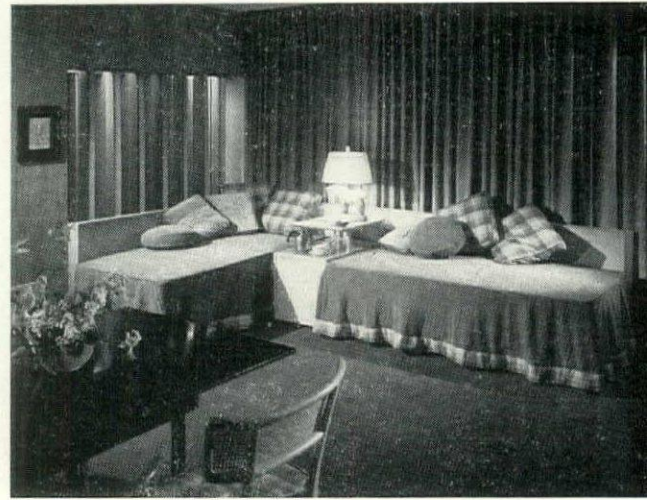

Lamp table between couches (above) is set on wheels for easy removal at bed-making time; opens (right) to hold pillows and linen.

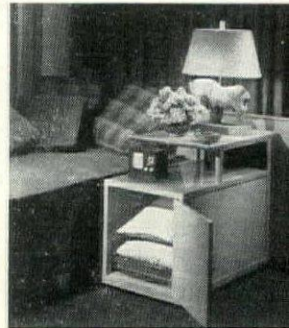

Sideboard (below) provides closet space, shoe compartments, shelves, drawers as well as mirrored vanity table.

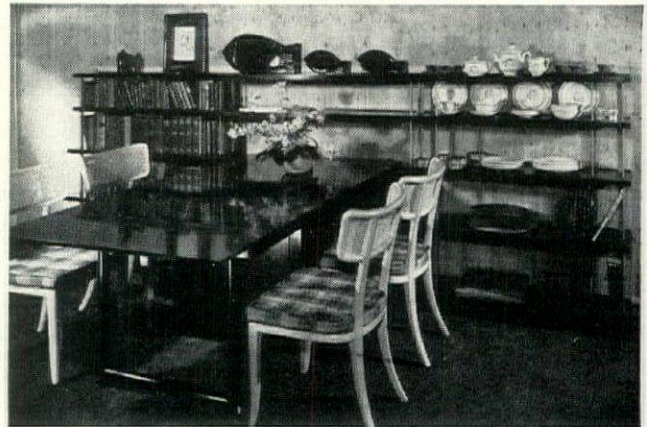
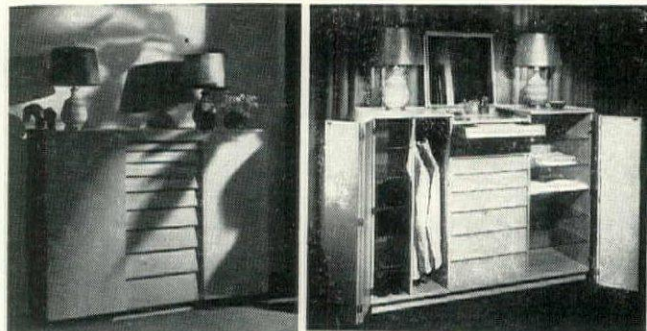

Living in one room ceased long ago to be a hallmark of indigence—a fact that Dunbar Furniture Co. has recognized in asking Edward Wormley to design "Progress House." This new grouping provides within the space of one large room (and at the cost of a few thousand dollars) for the combined needs of eating, sleeping and living. Best feature is Wormley's provision of varied storage space. In addition to well-thought-out cabinets, cleancut shelving in the dining area (wood with steel supports) proves equally adaptable for books and china.

(Continued on page 60)



Designed in PLASTER for complete flexibility

Architect Harris Armstrong, Kirkwood, Mo., chose plaster applied by the Campbell Plastering Company for the new office building of the American Stove Company, St. Louis. Plaster is economical and adaptable . . . it is completely responsive to the architect's imagination.

RED TOP

PLASTER

- ADAPTABLE
- FIRE-RESISTANT
- BEAUTIFUL
- LONG LASTING



United States Gypsum

For Building • For Industry

Gypsum • Lime • Steel • Insulation • Roofing • Paint

ANNOUNCEMENTS

THE MOST IMPORTANT SQUARE FOOT *in every kitchen you build!*



*That's where the
EMERSON-ELECTRIC KITCHEN
VENTILATOR goes!*

It's not a "mere detail" to those who work over a hot stove and breathe steam vapors that can't escape... for hours each day! That's why the square foot dedicated to an Emerson-Electric Kitchen Ventilator is so important... in pleasing clients, in making satisfied homeowners. Priced surprisingly low, easy to install in either brick or frame construction, these sturdy fans whisk out kitchen heat and cooking odors, prevent spread of greasy vapors to living room furnishings and walls. Available in two models, for wall or ceiling installation. For complete data, refer to Emerson-Electric Catalog in 1949 Sweet's Architectural File, or write for free Folder No. B-39.

THE EMERSON ELECTRIC MFG. CO.
ST. LOUIS 21, MO.

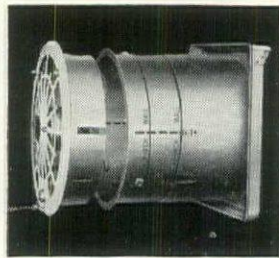

Wall-type Ventilator

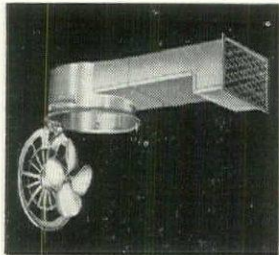

Ceiling-type Ventilator

EMERSON  **ELECTRIC**
MOTORS • FANS APPLIANCES

VERSATILE CHAIR LEG

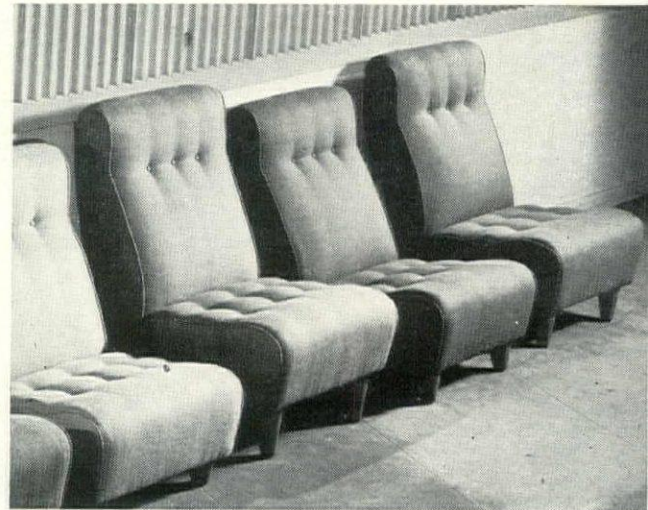

With the introduction of *Adjustoleg*, the Dunbar Co. claims to have inaugurated furniture that will not only fit the spine but fit the floor. These adjustable, removable and interchangeable wooden chair legs are available in seven lengths from 3 to 7 in. and are useful in varying not only the height but tilt of chairs (see above picture). It also provides a simple means of eliminating uneven-floor wobble for chairs and chests.

WESTINGHOUSE LIVABLE

"MOST LIVABLE HOMES" is the title selected by Westinghouse Electric Corp. to characterize the four complete houses it has built for exhibition in Hartford, Conn. Below is the cheapest—"The Thrift House" (\$12,000). This like the three higher-priced houses—"Budget," \$17,000; "Ideal," \$23,500; and "Deluxe," \$25,000—has been designed by Royal Barry



Wills in a Cape-Codesque style to avoid the "coldly mechanical" as well as the "awkwardly impractical." The result is held by a company spokesman to be "for the first time... a true blending of art and science in the business of building homes."

In spite of such up-to-date equipment as refrigerator, range, automatic clothes washer, ironer, water heater and ventilator (and in the "Deluxe" an electrostatic air purifier) Westinghouse Livable seems to shut its eyes to today's house—inside and out—and snuggle as close as possible to the house of yesterday.

(Continued on page 62)



\$2,000 DOOR PRIZE

Name the New **Roddiscraft Door**

1st Prize \$1,000 – 2nd and 3rd Prizes \$500 each



All you have to do is name the new Roddiscraft Door with the accordion type veneer core and follow the directions listed below.

About the Door Here are some facts about the door to guide you in selecting a winning name.

The new Roddiscraft door has a core made up of selected strips of veneer. These strips are spot-glued at intervals and stretched within the rails to form an accordion core design. This is a radical departure from the conventional core. The accordion core creates the strength and rigidity of a solid core with 50% less wood content.

Veneer strips are spaced 2" apart at points of greatest core-strip bending. This provides maximum support to the face panels and protects against puncture from abuse.

Face panels and rails are hardwood throughout. The whole assembly is pressure bonded with the finest glues obtainable and seasoned in specially constructed kilns for permanent straightness.

THERE YOU HAVE ALL THE FACTS YOU NEED TO THINK UP A PRIZE-WINNING NAME. PUT ON YOUR THINKING CAPS AND FOLLOW THESE SIMPLE DIRECTIONS:

1. Select the name you believe most appropriate and fitting. Then, in 25 additional words or less, complete the following statement: "I believe the new Roddiscraft Door with the accordion type veneer core is a superior door because" Each name submitted must be accompanied by a statement.
2. Send all entries to the Roddis Lumber and Veneer Company, Marshfield, Wisconsin. All entries must be mailed before midnight, November 20, 1948. Send as many entries as you please.
3. Entries will be judged on the basis of originality and aptness of thought by a panel of expert judges. All entries become the property of the Roddis Lumber and Veneer Company. The judges' decision will be final. In the event of a tie, duplicate prizes will be awarded.
4. The first prize winner will receive \$1000; the next two winners will receive \$500 each. All winners will be notified by registered mail.
5. This contest is open only to dealers and their employees and the employees of architectural firms, and millwork houses.

Roddiscraft Roddis Lumber and Veneer Co.
MARSHFIELD, WISCONSIN

ANNOUNCEMENTS

5 "Home Town" Schools Heated by Webster

In Camden, N. J., home town of the 60-year old Webster Organization, the Board of Education turned to Webster for solution of the diverse heating problems in both local high schools and one grammar school. Heating plans for the Camden Board of Education are made by William T. Harker, of William T. Harker & Associates, Consulting Engineers, who says:

"Putting Camden-made Webster Moderator Systems in our schools is more than a matter of home-town pride. We have found that it pays to do so. Comfort is increased. Heating costs are low. Webster has the equipment and the experience to solve our heating problems."

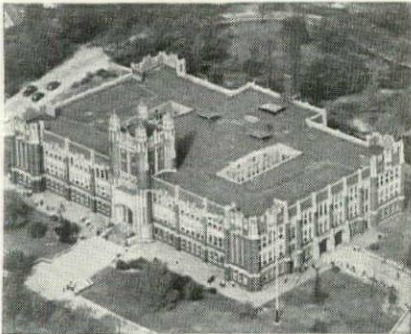

Camden Senior High School, Camden, N. J. Built 1918. Heating modernized 1945 with Webster Moderator System.

In one case the high pressure boiler plant was converted to low pressure. In another, return piping buried under the floor had become porous. In a third, wall-hung pipe coils were replaced with Webster Type WI Radiation.

Modernization of obsolescent or worn mechanical plants pay off—equal and sometimes even greater results can be obtained in other public buildings, warehouses, hotels, office buildings, apartments.

Write us about your heating problems. A trained Webster Representative will be glad to discuss it with you.

Address Dept. AF-10

WARREN WEBSTER & CO.
Camden, N. J.; Representatives in Principal Cities
in Canada, Darling Brothers, Limited, Montreal

Webster
HEATING

APPOINTMENTS

ROBERT ALEXANDER, (re-elected) president of the Los Angeles Planning commission; R. W. Harper, vice president.

IECH M. PEI, architectural consultant for Webb & Knapp, (New York City real estate firm), on urban and suburban redevelopment problems.

CHESTER FISK, engineer and former city manager of Berkeley, Calif., as manager of the Industrial Department of the San Francisco Chamber of Commerce.

CAPT. PAUL HALLORAN, U.S.N., as vice president of Foley Brothers, Inc., New York engineering construction firm.

JAMES TWOHY, former governor of the Federal Home Loan Bank Administration, to chairman of Investors Syndicate, nation-wide investment firm.

ORVILLE TAYLOR, new member of the board of directors, John W. Harris Associates, building construction firm.

A. C. MONTIETH, vice president in charge of engineering and research, Westinghouse Electric Corp., Pittsburgh, Pa.

NEW OFFICES

CHESTER LOWE, architect, and SAMUEL POPKINS, architect and engineer, in general practice, 8931 Carnegie Ave., Cleveland 6, Ohio.

RAYMOND KERMIT THOMPSON, A.I.A., 402 Equitable Bldg., Portland 5, Ore.

CARSON, KANTIANIS & KIRLEY, architects, Springfield National Bank Bldg., Springfield, Mass.

GRIGORE HIRSCH, architect and town planner, 35, Chowringhee, Calcutta, India.

WILLIAM G. LYLES, BISSETT, CARLISLE & WOLFF, architects, (formerly Stork & Lyles, architects) 1302 Main St., Columbia, S. C.

FRANCIS DODD MCHUGH, architect, and THEODORE MCCROSKY, engineer, consulting service on community and regional development problems, 23 E. 26th St., New York 10, N. Y.

NORMAN BEL GEDDES, industrial design consultant and director, 350 Park Ave., New York 22, N. Y. Mr. Bel Geddes' design staff (Norman Bel Geddes Corp.) will function as a separate unit located in Stamford, Conn.

AUGUST SPERL, JOHN GOWEN & CHARLES GREGORY, engineers and contractors, 441 Lexington Ave., New York 17, N. Y.

GENERAL ENGINEERING ASSOCIATES (Claude Engle, Jr., Milton Kellert, Morris Shapiro and Paul Weidlinger) 1928 I Street N.W., Washington 6, D. C.

NASH, CADMUS & VOEKLER, INC., consultants on waste disposal, 45 W. 45th St., New York 19, N. Y.

W. H. JANZEN, electrical engineer, Builders Exchange, 190 MacArthur Blvd., Oakland 10, Calif.

ROY REQUA & ASSOCIATES, industrial designers, 667 Madison Ave., New York, N. Y.

ROGAY MODEL BUILDERS, architectural and commercial models and displays, 1822 M Street, N. W., Washington 6, D. C.

PASCOE ASSOCIATES, modern home furnishings, 10 W. 55th St., New York 21, N. Y.

(Continued on page 64)

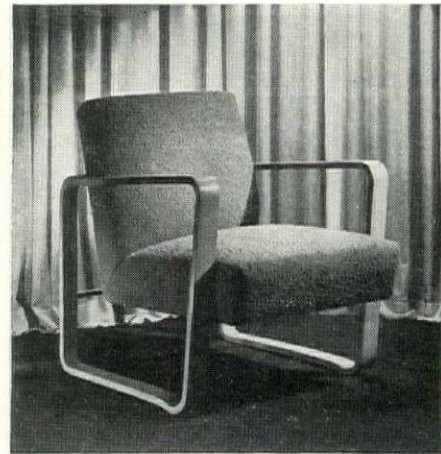

Open Arm Chair with continuous laminated supports and metal connecting parts.

DUNBAR

For
MODERN

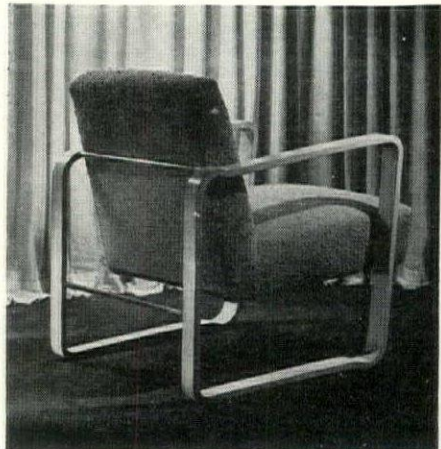

Send 25 cents for 28-page profusely illustrated booklet packed with Modern decorating ideas.

DUNBAR FURNITURE MANUFACTURING COMPANY

BERNE, INDIANA

1638 Merchandise Mart, CHICAGO 54, ILL.

203 Clarendon St., BOSTON 16, MASS.

227 E. 56 St., NEW YORK 22, N. Y.

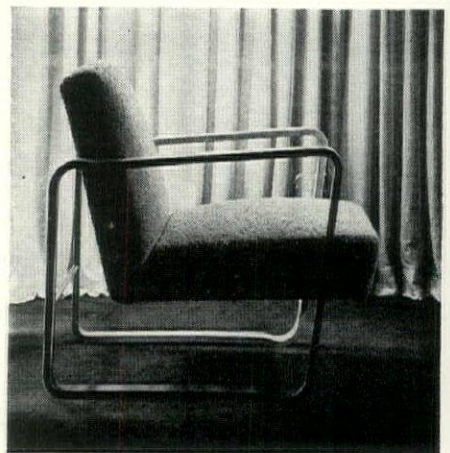

YOU CAN CREATE THE PROPER MOOD

POWERSTAT Dimmers — dimming, brightening or blending light — can help create the proper mood. In stores, it makes merchandise more appealing, keeps personnel alert and cordial. In hotels, the air of luxurious living and fine service is enhanced by proper lighting treatment. In cocktail lounges and restaurants, changing light treatment adds profitable dollars to beverage and food checks — increases clientele and promotes repeat business.

The art of using light to create desired effects and moods stems from the theatre, where POWERSTAT Dimmers give smooth, precise control. In churches, the judicious use of light — controlled by POWERSTAT Dimmers — can intensify the atmosphere of dignity and reverence. And school auditoriums, gymnasiums and play stages, made more interesting through POWERSTAT Lighting Control, increase rental revenue and frequency with this modern economical equipment.

STORES

HOTELS

LOUNGES

THEATRES

RESTAURANTS

CHURCHES

SCHOOLS

by using POWERSTAT LIGHT DIMMING EQUIPMENT

POWERSTAT Dimmers, versatile in application, *steplessly* dim any number of lamps up to rated load from complete black-out to full-on. They dim by transformer action without heat loss — handle incandescent or cold-cathode installations with equal economy, efficiency and precision.

Designed for manual or motor-driven operation, for direct or remote control, POWERSTAT Dimmers are available in numerous standard units to meet your specific requirements.

Write today for helpful, detailed information on POWERSTAT Light Dimming Equipment.

4118, Demers Avenue, Bristol, Connecticut

THE SUPERIOR ELECTRIC CO.
BRISTOL, CONNECTICUT



Powerstat Variable Transformers • Voltbox A C Power Supply • Stabiline Voltage Regulators.

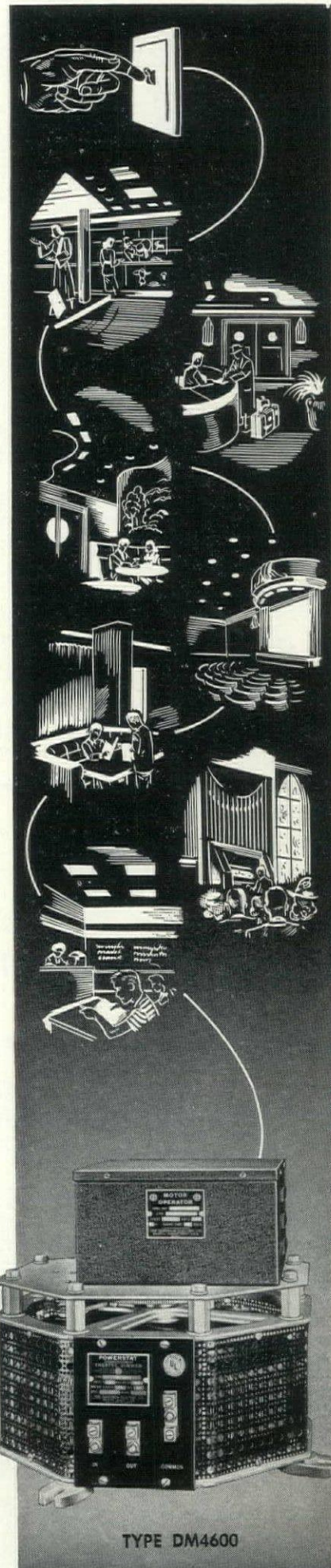

TYPE DM4600

ANNOUNCEMENTS

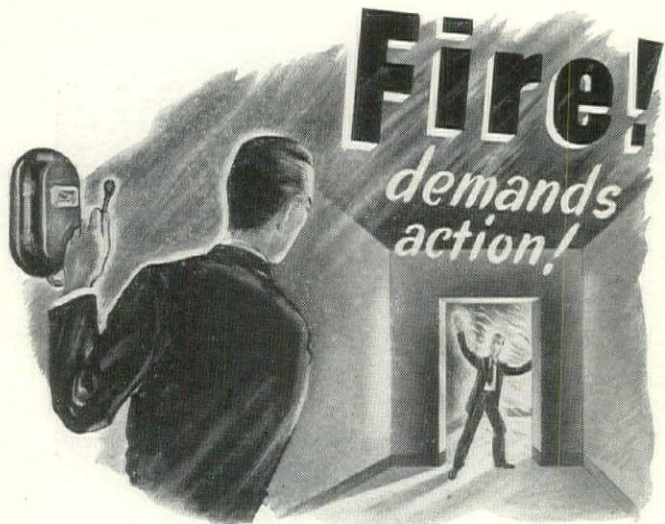

Couch Fire Alarm Equipment is *always* ready for action . . . ready to warn personnel of impending danger . . . to summon help for saving lives and property . . . to avert disaster.

Built to stand the test of time . . . quick in its response when urgent need calls it into action, Couch equipment is a reliable, silent guardian of life and property. With Couch equipment on the job, you get *action* . . . and you get it **FAST**, when you need it.

*Write for Illustrated Catalog
on your Company Letterhead*

S. H. COUCH COMPANY, INC.

Dept. 310 North Quincy 71, Mass.

PRIVATE TELEPHONES for HOME and OFFICE . . . HOSPITAL SIGNALING SYSTEMS . . . APARTMENT HOUSE TELEPHONES and MAILBOXES . . . FIRE ALARM SYSTEMS for INDUSTRIAL PLANTS and PUBLIC BUILDINGS

CHANGES OF ADDRESS

NEW YORK CITY HOUSING AUTHORITY, 63 Park Row, New York City, N. Y.

DAVID SEARCY BARROW, architect, 333 Park Ave., Glencoe, Ill.

HARPER RICHARDS, industrial designer, 160 E. Superior St., Chicago 11, Ill.

SCHULMAN & SOLOWAY, architects and engineers, 100-15 Queens Blvd., Forest Hills, N. Y.

BASSETTI & MORSE, architects, with MARY BASSETTI, interiors, 1621 Boren Ave., Seattle 1, Wash.

ROBERT HELLER, INC. industrial designer (formerly Robert Heller Associates, Inc.), 161 E. 61st St., New York, N. Y.

PANORAMIC STUDIOS, 6122 N. 21st St., Philadelphia 38, Pa.

OMISSION

Credit for the design and development of the ABBOTT LABORATORY PHARMACEUTICAL PLANT in Montreal, Canada (published in the August issue of *The Forum*, pp. 98-100) should have been given to the firm of Battey & Childs, Chicago consulting engineers (with special mention to their staff architect, T. Q. Hoffman, who coordinated the design) and to the Canadian engineer firm, Surveyer, Nenniger & Chenevert, associates on the job.

SYLVAN BIEN, New York architect, should have been credited as the designer of the Minskoff apartment pictured on the bottom of p. 93, June '48 issue of *The Forum*.

More than 10,000 families are living in these two famous New York housing projects

STUYVESANT TOWN and PETER COOPER VILLAGE

are comfortably heated by

DUNHAM "VARI-VAC" DIFFERENTIAL HEATING SYSTEMS and DUNHAM CONVECTORS

"VARI-VAC" Gives { ACCURATE TEMPERATURE CONTROL meeting exactly all changing weather conditions
UNSURPASSED COMFORT: No overheating • UNMATCHED FUEL SAVINGS reflected
in lower rental rates • REDUCED OPERATING AND MAINTENANCE COSTS



C. A. DUNHAM COMPANY, 400 West Madison St., Chicago 6, Ill.
Toronto, Canada • London, England

HERE'S HOW IT'S DONE

Steam under varying vacuums permits the reduction of steam temperature in piping and radiation to as low as 133° instead of a 212° fixed steam temperature. Cooler steam is circulated in mild weather and/or when inside building conditions require less heat. No cold convectors—each convector, regardless of location, receives its required supply.

A Vari-Vac System to fit any size job or budget

DUNHAM

HEATING MEANS BETTER HEATING

Copyright 1948

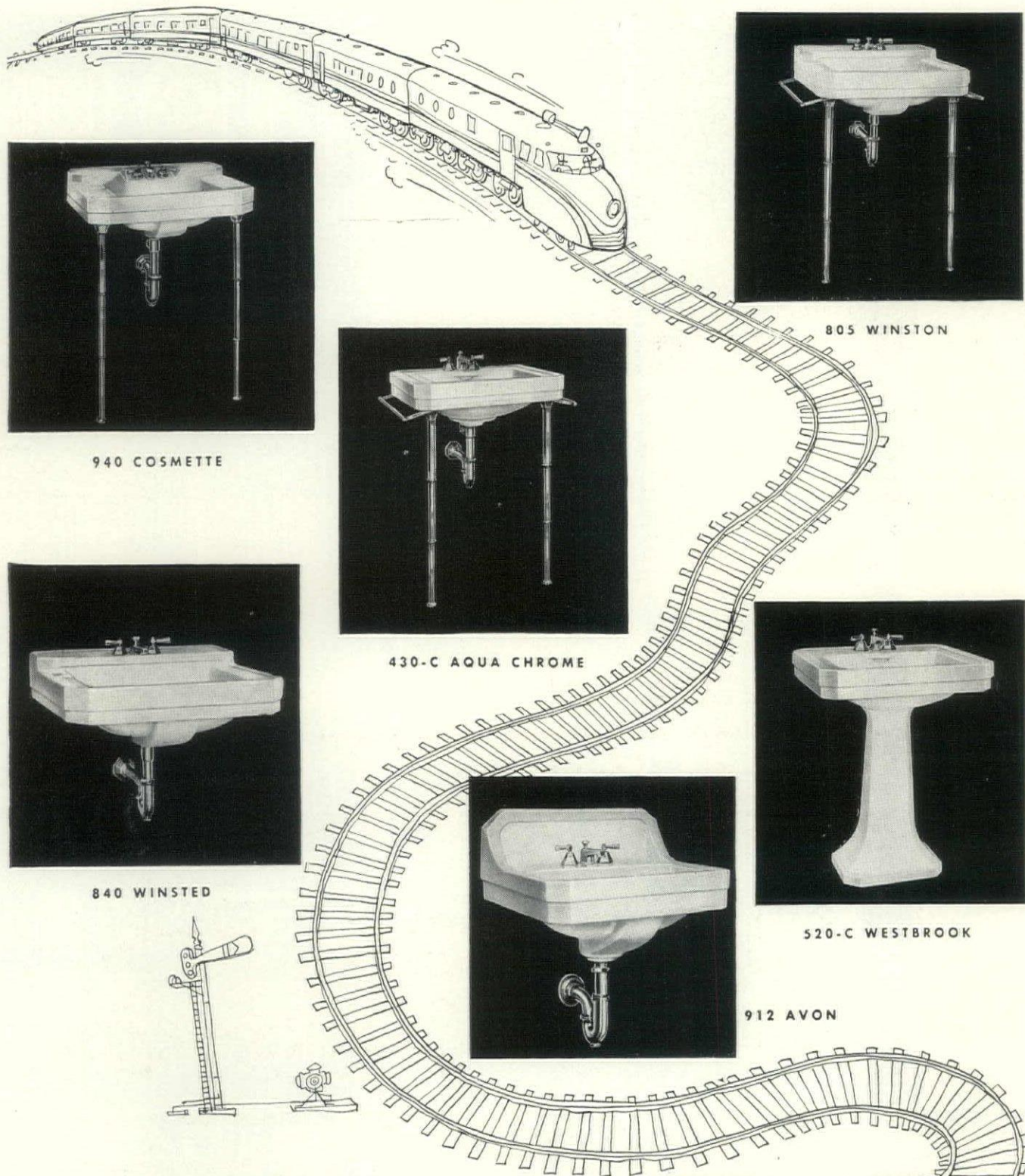

Are you riding a Class 1 Line?

Quality-minded customers are pleased to go along with you... when you specify quality fixtures. You can provide the pleasing design, mechanical excellence and lasting beauty of Case lavatories in styles and sizes for every situation. And you'll also save money for your clients on installation cost. Use the services of your Case distributor...listed in Classified Telephone Directories from coast to coast. W. A. Case & Son Mfg. Co., Buffalo 3, New York.

1853 • 1948
Case
 95 YEARS OF SERVICE

Vitreous China Plumbing Fixtures



"No other cooling and heating system has given us the comfort, the efficiency, and the perfect performance we are now enjoying from our Servel All-Year Air Conditioner," reports Henry Korufel, Ontario, California.

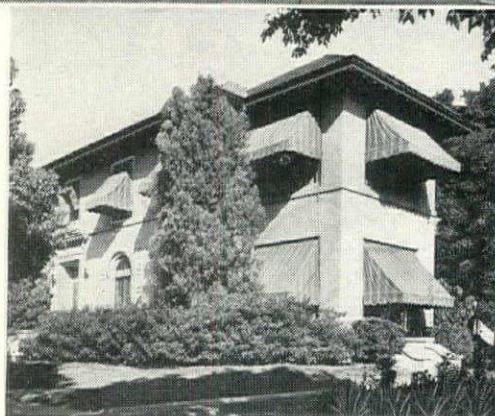

"With Servel All-Year Air Conditioning, we had mountain coolness, even temperatures and comfortable humidity all summer long," reports George J. Wetzel, Monroe, Louisiana.

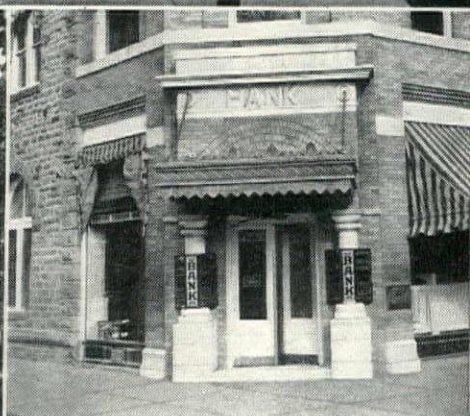

"The Servel units installed for air conditioning our banking quarters have proved very satisfactory and economical," says J. H. McElroy, Citizens National Bank, Okmulgee, Oklahoma.

owners report:

"mountain coolness in summer!"

"economical to operate!"

"perfect performance!"

"plenty of warmth in winter!"

Your clients, too, will welcome the year-round comfort of Servel All-Year Air Conditioning

You've got plenty to back up your recommendations when you talk Servel All-Year Air Conditioning to your clients. Hundreds of installations are already operating successfully from coast to coast. And, as the representative testimonials on these pages indicate, owners everywhere are delighted with the comfortable temperatures and humidity, the dust- and pollen-free air, that Servel All-Year Air Conditioning provides every day in the year.

Servel is completely different from any other air conditioning system. One single unit—operating through scientifically designed ducts and registers—offers complete, *six-phase*, year-round air conditioning. In summer, Servel (1) cools the air to refreshing temperatures,

(2) removes sticky, wilting humidity. In winter, the same unit (3) supplies plenty of clean, even warmth in every room, (4) adds just the right amount of moisture to the air for comfort. Throughout every season, Servel (5) filters out dust, dirt, and irritating pollen, and it (6) provides even, draft-free circulation of the conditioned air.

Planning your clients' buildings around Servel permits you greater freedom in design and also materially reduces construction costs. Once installed, Servel is economical to operate. Every unit is backed by a five-year factory warranty against defective parts.

Whatever the job on your desk right now—a home, store, office, bank, clinic, radio station—chances are that we have case histories on parallel applications in our files. We'll be glad to furnish such information and any other data you may need. Just write to your local Gas Company or to Servel, Inc., 2810 Morton Avenue, Evansville 20, Indiana.

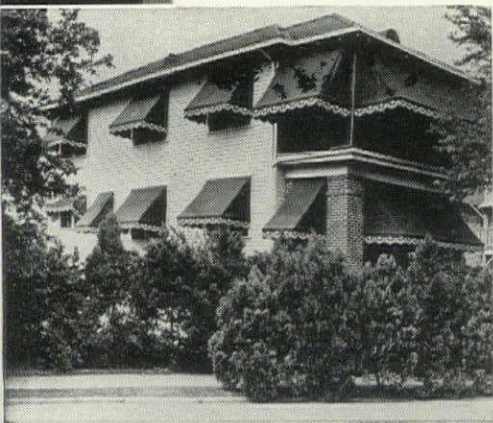

"We are very much satisfied with our investment in a Servel All-Year Air Conditioner," writes Clay W. Beckner, 5 Newcomb Boulevard, New Orleans, Louisiana.

Servel

All-Year

AIR CONDITIONER

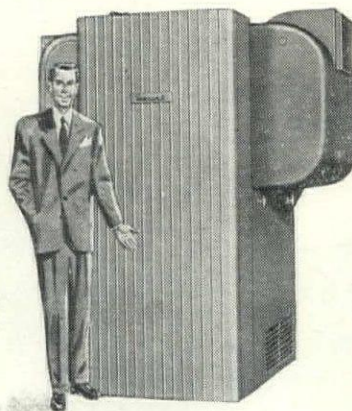

POSITIVE AIRFLOW CONTROL

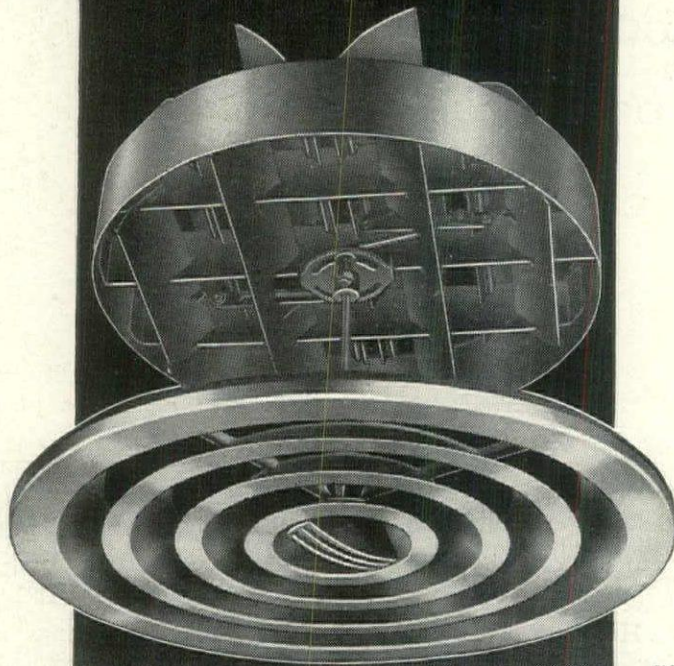

WITH THE IMPROVED
**AEROFUSE
DAMPER**

At the vital point of air delivery you measure the real efficiency of an air conditioning system. And, of course, the selection of air distribution equipment largely determines performance.

Take our improved Aerofuse Multi-Louvre Damper, for example. Balanced system assured by minute adjustment of air volume . . . convenient to regulate. Multi-Louvre

construction divides supply stream, gives uniform distribution over entire outlet . . . and with minimum turbulence in air stream,

quiet operation. In open position, damper provides effective area greater than that of corresponding size diffuser . . . closed, it

assures complete shut-off. Tamperproof,

louvres can be positively locked in any position . . . or, if desired, operator handle and

rod may be removed to maintain established setting.

These are *exclusive* T & B designed-in features. As a result, when you specify Aerofuse ceiling diffusers—equipped with the Damper—for installation at the distribution end of air conditioning systems, you can be *sure* of effective, efficient control...the proper amount of supply air, delivered as you want it, where you want it, evenly distributed and without drafts.

THIS COUPON

... Will bring you complete details and engineering data on the improved Aerofuse Damper. Mail it today!

Rush me complete information on the Aerofuse Damper.

NAME			
COMPANY			
ST. & NO.	CITY	ZONE	STATE

a development of

TUTTLE & BAILEY

NEW BRITAIN, CONNECTICUT

A \$10,000 DESIGN CONTEST

conducted
by
THE ARCHITECTURAL FORUM
for
DAVID E. KENNEDY, INC.
manufacturers
of
KENTILE
Asphalt Tile



A new national survey reveals a major trend in flooring—the ever increasing and imaginative use of smooth surface asphalt tile floors, laid tile by tile, in all types of interiors, including every room of the home.

Many factors have stimulated this trend. One is the continued technical refinement of asphalt tile itself. For instance, Kentile has introduced a new post-war resilience that considerably increases the opportunities for installation on wood. Concurrently, an improved formulation has made it one of the most easily cleaned and maintained floors. Its precise die-cutting permits the ultimate in tight fitting, virtually seamless installation. Its better marbleizing and coloring set a new standard for floor beauty.

But most important, probably, is the discovery by architects of the unlimited opportunity for *original design* provided by Kentile. They have come to realize that this modular flooring with 23 colors, each available in 6 standard sizes, plus the functional feature strips in 5 colors, offers infinite scope to their creativeness.

This trend, we believe, affects the entire field of architectural designing and is worth more complete investigation. We therefore are sponsoring this competition to further attract the creative attention of architects, designers, draftsmen and students—to stimulate additional exploration of this new interior design potential.

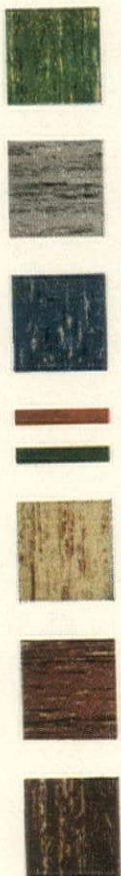

THE PROBLEM: Given the essential structural elements of a residential or commercial area, design a noteworthy interior that uses a Kentile floor as an element of the decorative scheme.

Competitors may choose to work on any one or all of three problems—a kitchen-dining area, a living area, or a candy shop—and need submit only a simple plan that includes the Kentile floor design and a perspective sketch demonstrating the entity of the floor design and the decor.

Both plan and sketch should be quick and simple, prizes being awarded primarily for the design thinking, with skill in presentation considered only insofar as it presents the design ideas clearly and concisely. Painstaking and time-consuming renderings are not sought.

Approved by the American Institute of Architects

54 PRIZES—OVER \$10,000

	Kitchen-Dining	Living Area	Candy Shop
First prize	\$1,500.	\$1,500.	\$1,500.
Second prize	750.	750.	750.
Third prize	500.	500.	500.
15 Honorable Awards of \$50 in each class	750.	750.	750.
	\$3,500.	\$3,500.	\$3,500.

This competition is limited to residents of the continental United States and Canada. Employees of David E. Kennedy, Inc., of The Architectural Forum or of advertising agencies serving the above, are not eligible. Contestants must register in order to receive the program and complete instructions. The competition closes at midnight, January 10, 1949.

C. Theodore Larson, Professional Adviser, c/o The Architectural Forum
Empire State Building, 350 Fifth Avenue, New York 1, N. Y.

I intend to enter the Kentile Design Competition. Please send me the program, including the conditions governing the competition and awards.

Name.....

Firm (if any).....

Address.....

City..... State.....

Check one: Architect..... Designer..... Draftsman..... Student.....

Other Occupation.....

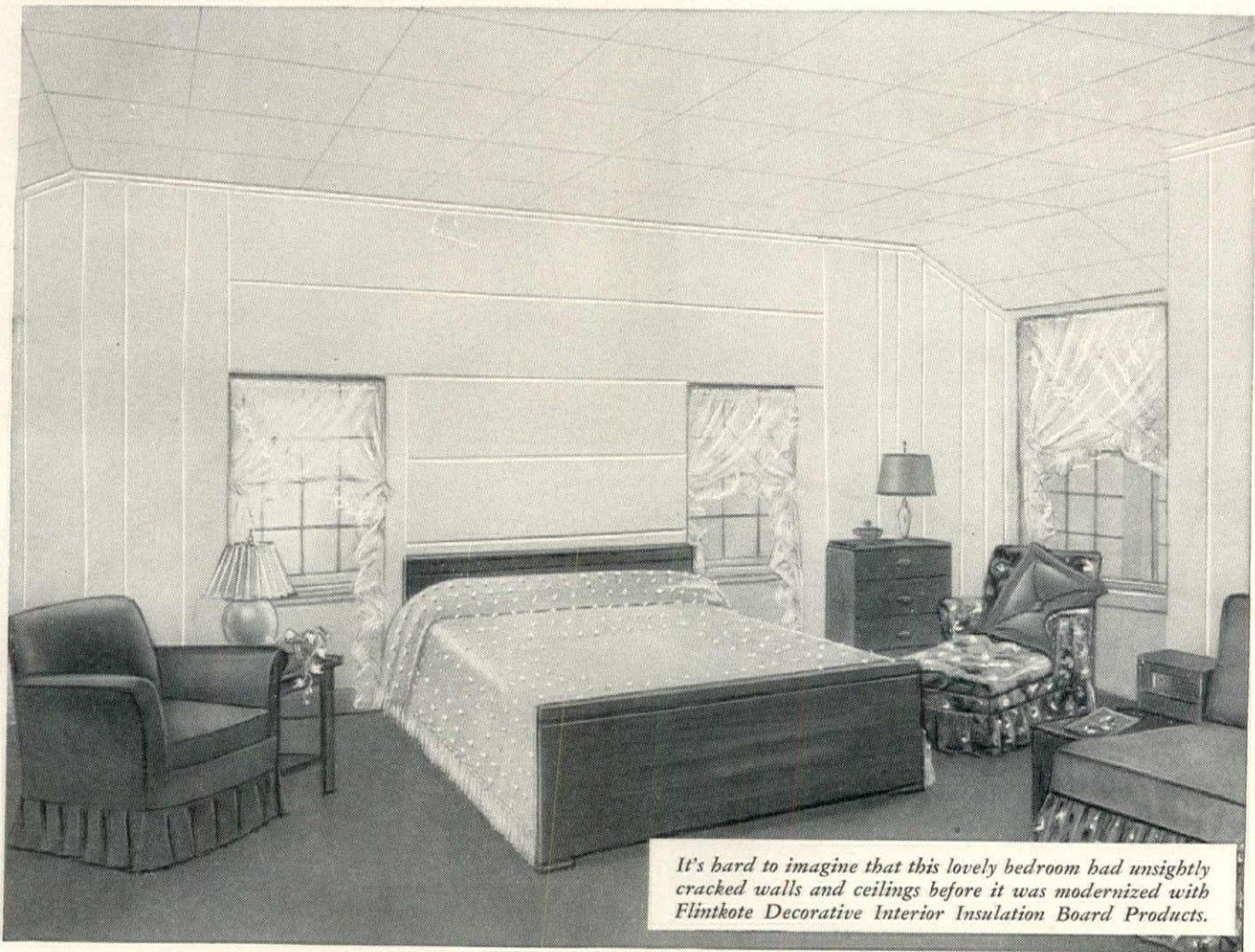

It's hard to imagine that this lovely bedroom had unsightly cracked walls and ceilings before it was modernized with Flintkote Decorative Interior Insulation Board Products.

Everybody **GETS THE BEST OF THIS BARGAIN!**

It isn't often you can say about a building material, "Well, this makes everybody happy." But with Flintkote Decorative Interior Insulation Board Products, that dream comes true.

For smart interiors . . . either in remodeling or new construction . . . Flintkote Decorative Interior Insulation Board Products can work wonders in any room. Here, quick, easy application is an important characteristic. The Flintkote Blind Nailing Joint helps builders complete a *super*-finished job in jig time.

And with all Flintkote Insulation Board Products, you get bonus portions of characteristics that give any home-owner something to shout about—Permanence, Beauty, Convenience and Livability. Remember, too, that you give owners the double-duty value of a mate-

rial that is high in insulation value and at the same time possesses structural and decorative qualities.

So specify these popular products . . . and everybody will get the best of the bargain. For a bargain it is . . . the price in relation to the values delivered is surprisingly economical.

For complete information, see Sweet's or write us. We'll rush you full details.

THE FLINTKOTE COMPANY, *Building Materials Division*, 30 Rockefeller Plaza, New York 20, N. Y.



FLINTKOTE

the extra years of service cost no more!

The Architectural **FORUM** Magazine of Building

Hedrich-Blessing photographs



PROGRESS IN ST. LOUIS — the American Stove Comp



... up an enlightened administrative headquarters and sales display building

HARRIS ARMSTRONG, Architect

Color photos: Hedrich-Blessing

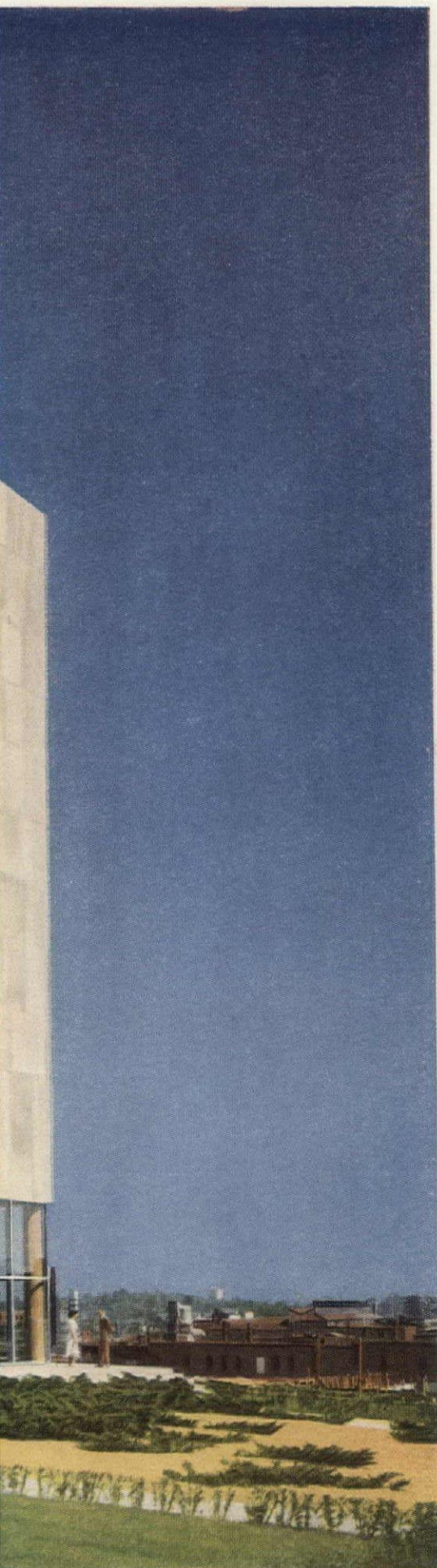

Herewith recognition of a perceptive group of industrial executives, for their intelligence in deciding to build this kind of display-and-headquarters building, and for their fine sense in retaining the right architect.

American Stove produces more gas ranges than any other company. Since the merger in 1901 of seven smaller companies into the present corporate setup, sales have mounted as high as an estimated \$32,000,000 plus for this year (prewar peak \$14,000,000). Out of five factories in the midwest are trundled daily regiments of vestal white Magic Chef ranges, bound for the homes of happy housewives.

When the proprietors of all this activity decided to consolidate their awkwardly scattered administration headquarters in St. Louis into one commanding structure, something auspicious was clearly in order, but that hardly guaranteed good architecture. Other mighty companies have faced the same situation, and many of them have failed auspiciously to own a building which fulfills their physical needs and at the same time is an attractive monument to their enterprise.

But American Stove Co.'s directors and executives did not make the obvious mistakes, as their building bears witness. Their staff of 107 is officed in a handsome, comfortable structure: handsome in its rich surfaces and simplicity of form as it dominates the nearby area from a slight rise; comfortable in its up-to-the-minute air conditioning, lighting, and interior design.

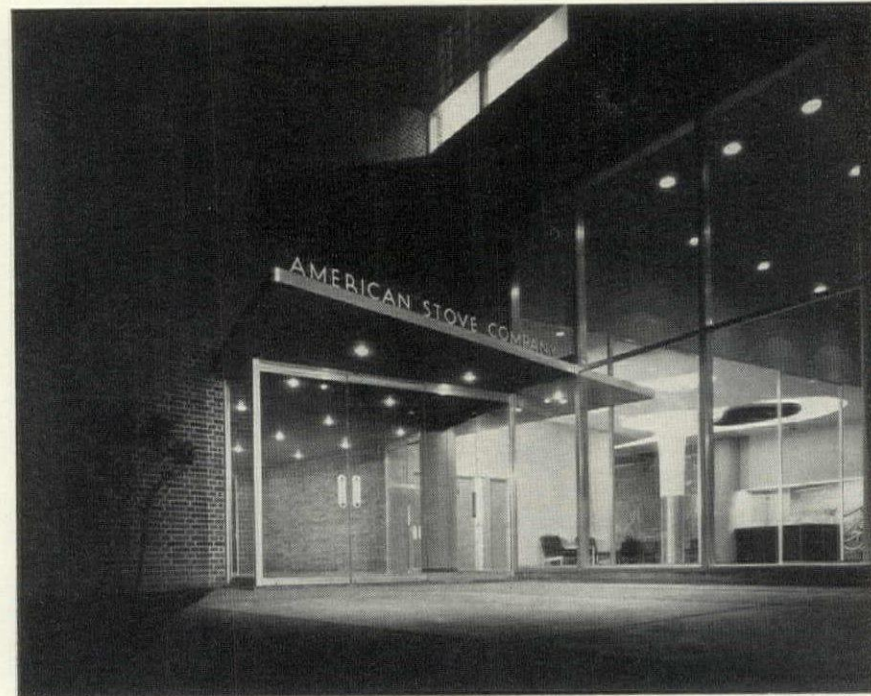

Typical of the approach to one side of the environment, the visual, is a part of the lobby whose illuminating ceiling is a work of sculpture integral with the architecture, by Isamu Noguchi (page 74). The highly successful work surely is unique in institutional building, together with the spirit that prompted and encouraged it.

Typical of the scientific approach to environment is the office fenestration, a notable feature of this building. Differences in exposures were recognized and expressed. Offices in this building do not rely upon artificial lighting except on exceptionally dull days, but are almost always entirely daylight. Only two exposures are used for lighting: the north, with clear double glass, and the south, with a combination of clear double glass and directional glass block (for FORUM lighting engineer's study and criticism of this daylighting design, see pages 76 and 77).

Articulated massing separates the functions, and each exposure is tailored to fit its demands

Hedrich-Blessing



WEST EXPOSURE, ABOVE, IS BLANK, AS IS EAST EXCEPT IN SHOWROOM; NORTH AND SOUTH SHOW DIFFERENCE IN LIGHTING TECHNIQUES

Brickwork in American Stove's new administrative headquarters is oversize sand finish local brick—a handsome gesture to the building past of old St. Louis. Landscaping is by the architect's office, featuring areas of gravel the same color as the brick, planted with prostrate junipers. Expansion opportunities exist both upward and onward; footings are designed to support a seventh floor, and the plan would accept gracefully another wing. The air conditioning system draws only hot and cold water from the central heater, with a separate fan room on each floor. Distributing ducts are in the ceiling, with returns under the floor. Gas is the main heating fuel; oil-burning facilities are present, but get little use.

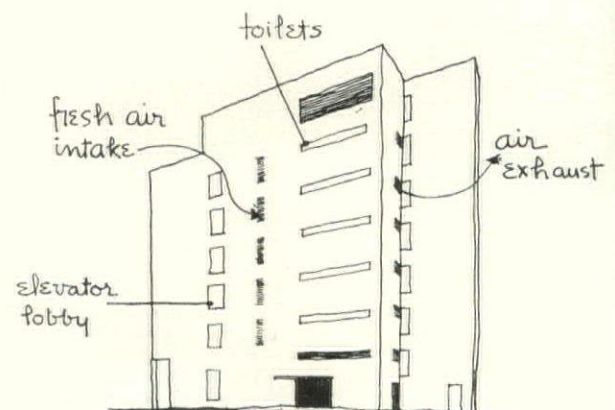

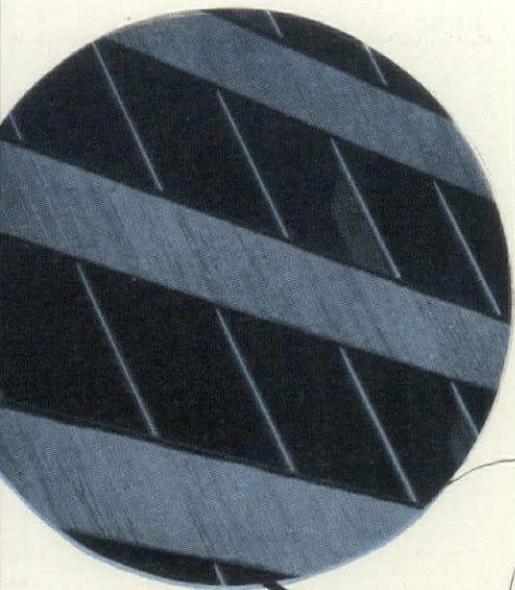

N

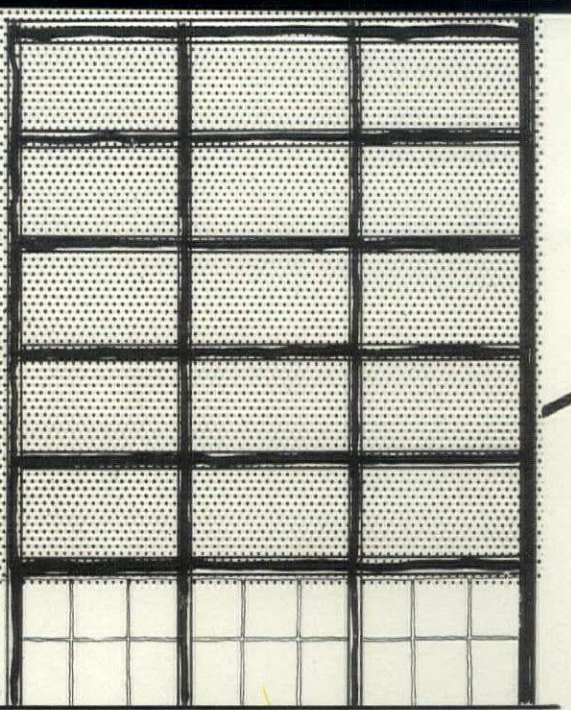

EAST ELEVATION

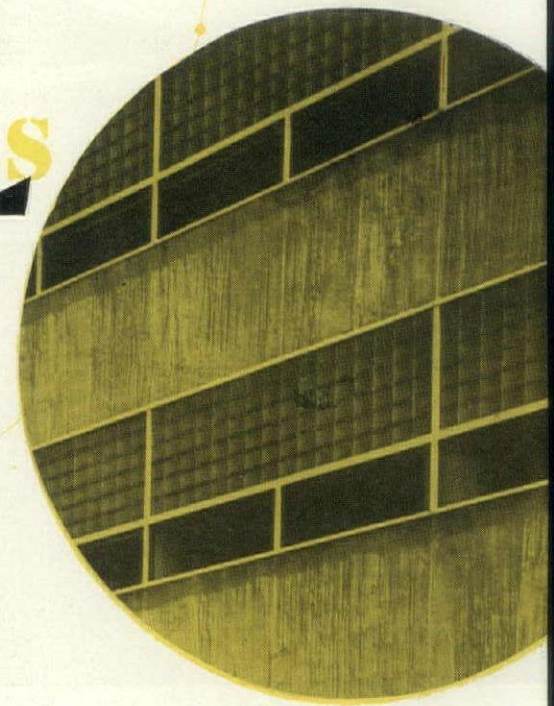
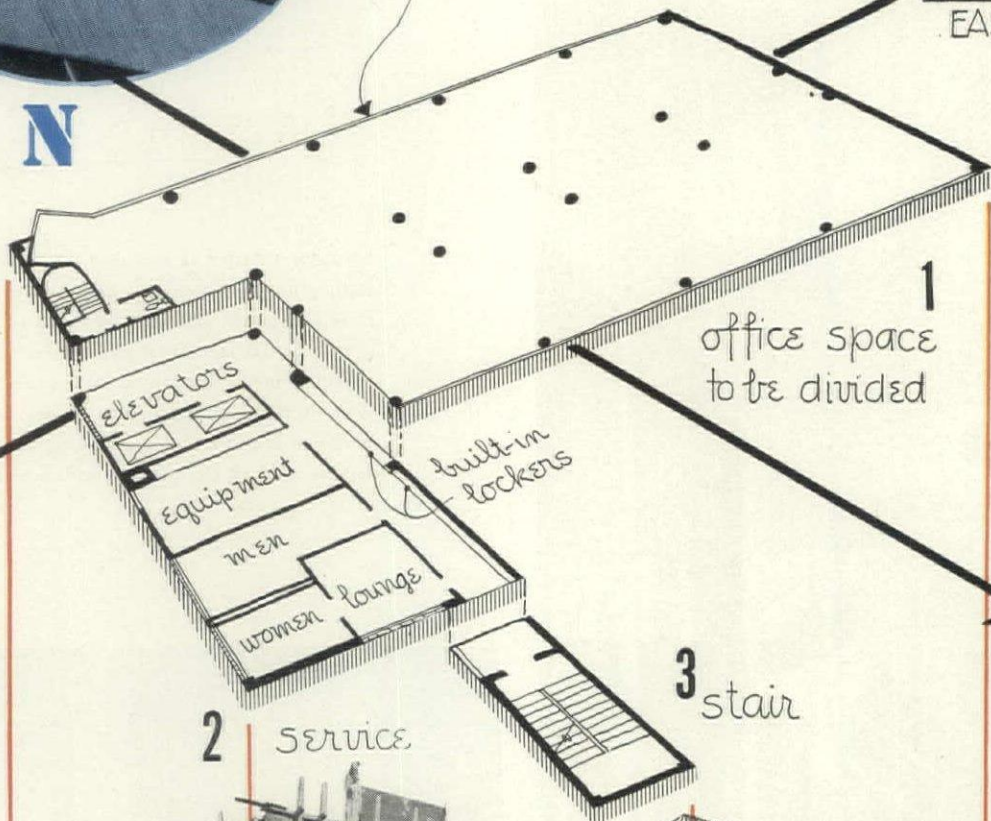

S

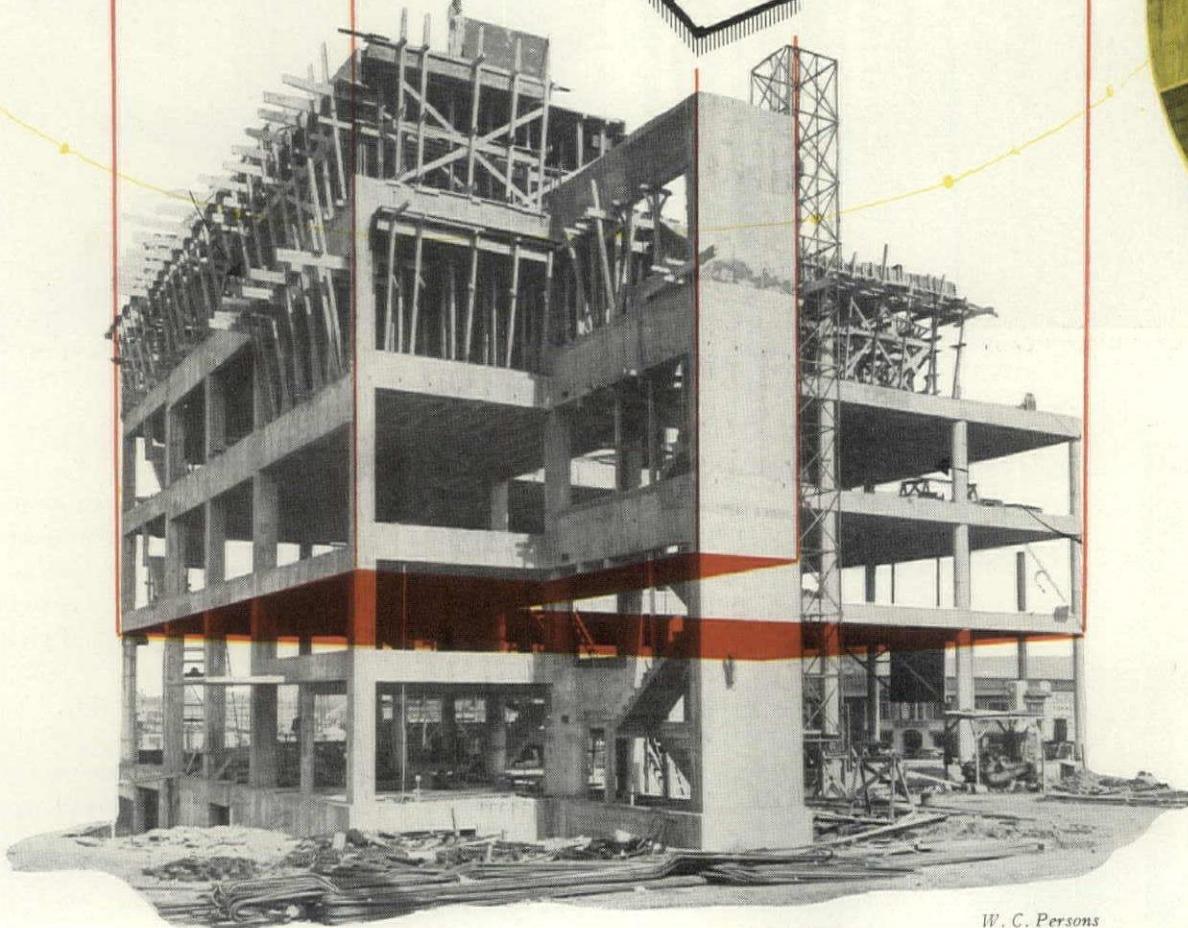

“Decoration is rather an unnecessary and unwanted thing in modern architecture . . . sculpture is a devel

Noguchi designs a ceiling lighting fixture, dominating the display lobby floor

Hedrich-Blessing

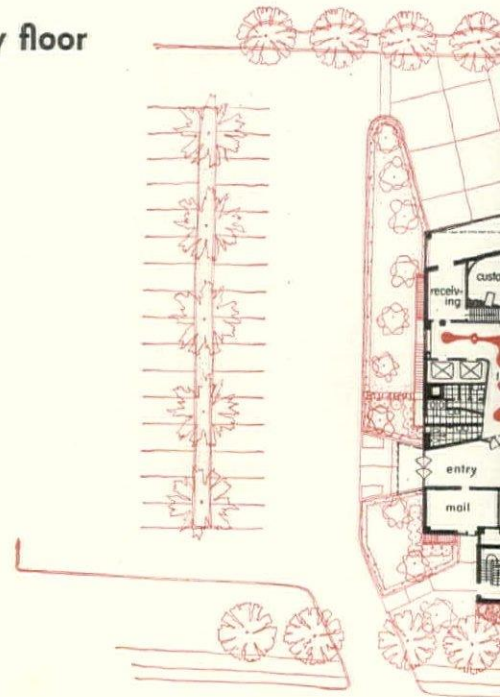

LAVISH LOBBY is featured, past entry, by a ceiling lighting fixture—the work of sculptor Isamu Noguchi. Mezzanine for sales offices is above. A large high display room, glazed on all sides, uses the bulk of the remaining space to show the complete line of ranges. A field of spotlight fixtures in the ceiling does double service as distributor for conditioned air.

W. C. Persons

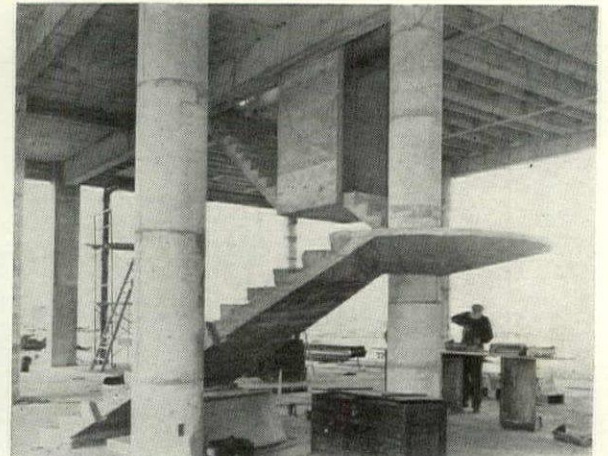

NOGUCHI'S CEILING WAS BUILT BY UNION PLASTERERS FROM HIS MODEL; STAIRWAY LEADS TO SALES OFFICES ON MEZZANINE

SCULPTURE IS NEATLY DIRECTIONAL



Says Isamu Noguchi: “At some point architecture becomes sculpture, and sculpture becomes architecture; at some point they meet. We have to discover what that point is. For instance a wall is an element of architecture. The dimensions of that wall are also an element of sculpture . . . The sculpture should no longer be just something stuck on the architecture, but a development of the architecture itself—what you might call an emotionally functional as well as just a mechanically functional thing—to accent and punctuate, giving dimensions to space. When you put a sculpture within a given space, it allocates the space and gives it a dimension.

“Sculptures plastered on the wall do not really give the building a quality. That is nothing more than mere illustration.

“There is great need with all these new projects being planned to have thoughtful regard given to sculpture and architecture. Environment should make you feel better, feel happier to be there—that’s my idea of what sculpture should do.”

of the architecture itself . . .”

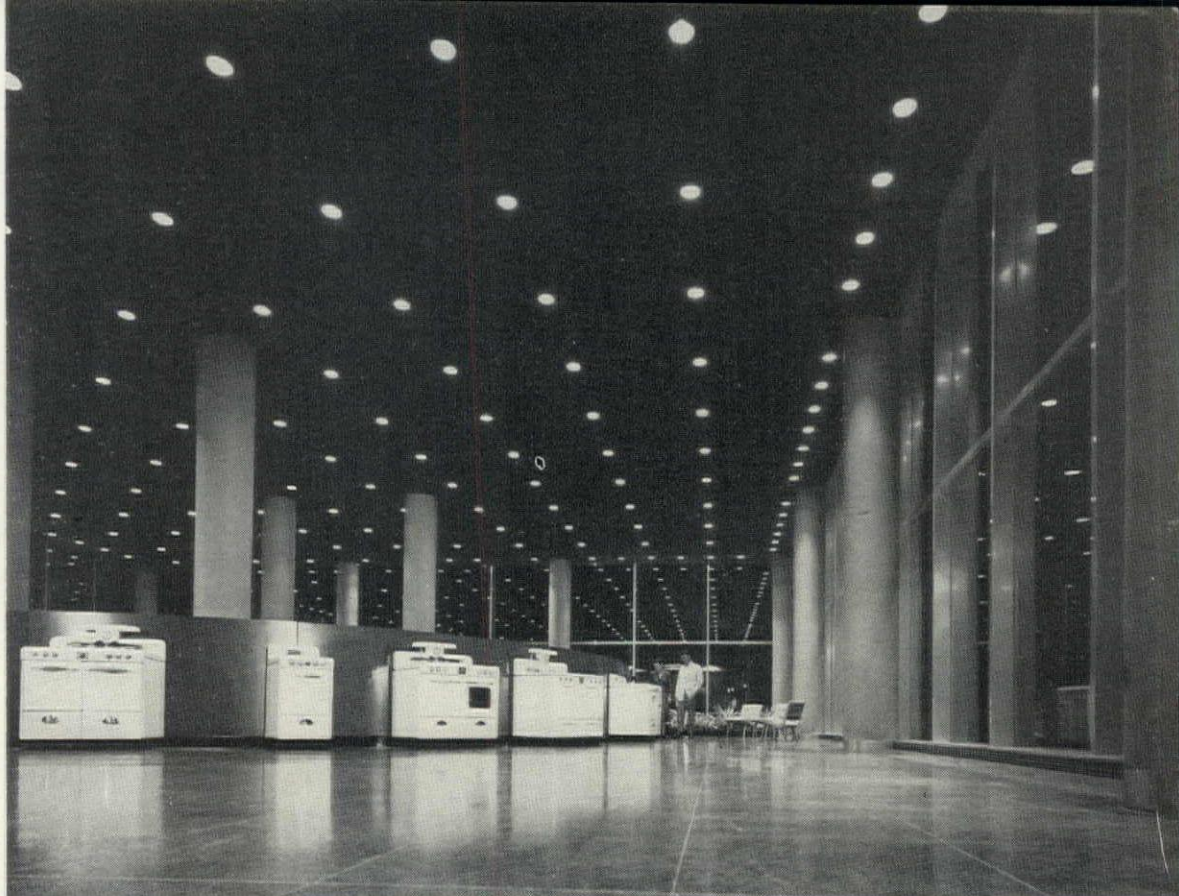
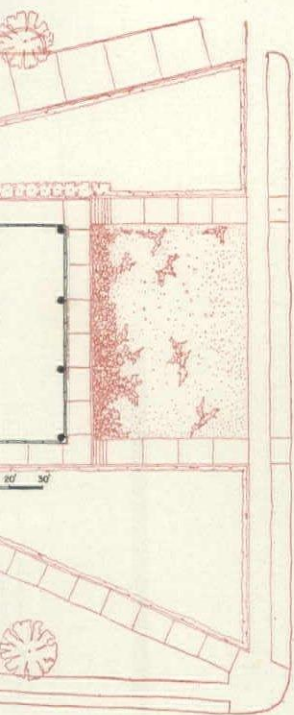

SPACIOUS DISPLAY AREA ON FIRST FLOOR DRAMATIZES THE COMPACT KITCHEN RANGES

VIEW TOWARD ENTRANCE IN LOBBY OF DISPLAY ROOM; NEW BUILDING HAS MULTIPLIED NUMBER OF APPLICANTS FOR JOBS IN COMPANY



DAYLIGHTING—a complicated challenge fosters a scientific solution

The problem of daylighting, as any other problem, begins to get really complicated only when you get close to the solution. Much credit is due architect Armstrong's office not only for their recognition of the opportunity to daylight this building interior, but also for the directness of their design for daylighting and for their lack of deviation from original theory. The north-south attack in orientation is followed through completely in lighting the offices, with no east or west windows. From that point the problem, stated at its simplest, is to light each of two specimen office spaces 26 ft. deep from the outside wall, one with north exposure, the other with south exposure. Situations and factors involved are discussed in more detail below, with their complications, but the general answer has been this: big continuous areas of clear glass on

the north, clear glass and prismatic glass block on the south. Neither fenestration is unprecedented. Even before the development of glass block, architects decades ago were reaching in the same general direction with use of Luxifer block above clear glass on facades. But as an example of up-to-the-minute application of known daylighting principles, this building would be difficult to surpass. Standards of objective and subjective comfort in natural daylighting are not poorly defined now; since these standards seemingly can't be defined other than empirically, completed, occupied buildings like this are especially valuable for study. Observations and illumination and brightness readings on these pages are from a special study of this building for FORUM by lighting engineer Bernard F. Greene.

CONVENTIONAL window system would place sets of windows in regular patterns on both the north and south sides of the building, with poor distribution of illumination. Another great disadvantage of this lies not only in the fact that insufficient light is admitted on overcast days, but the great brightness contrast between the glass area and the wall area of the window wall is jarring to the human eye and is therefore a source of fatigue.

NORTH WINDOWS in the American Stove Co. are designed to admit the maximum amount of usable light. The glass area is more than twice that common in conventional fenestration, so the amount of light admitted is much greater (see figures on diagrams). And because there is no solid wall curtain in the normal view in the window wall here, there is no dark silhouette, wall against sky, to annoy and tire the eye. Lighting is good all over room even on dull days.

SOUTH WINDOWS are designed on same general principles as north—a lot of glass admits a lot of light. But the problem is somewhat intricate on the south: direct sunlight is not good light for office work; therefore, even conventional slot windows (above) must have some curtaining arrangement to block direct rays. With large glass window walls, this problem is enlarged. The solution of blinds or window shades to deflect or diffuse sunlight is good only in a very shallow room. In a deep area, any mechanical blocking of the sun's direct rays by shades, blinds, or overhangs does not allow enough

CLOUDY weather, which is the condition roughly half the time, raises no problems with prismatic block. Natural light on all desks, see diagram, is better than adequate, and much better than possible with slot windows. Clear glass all the way to the ceiling might send more light to rear desks on cloudy day than combination of glass block

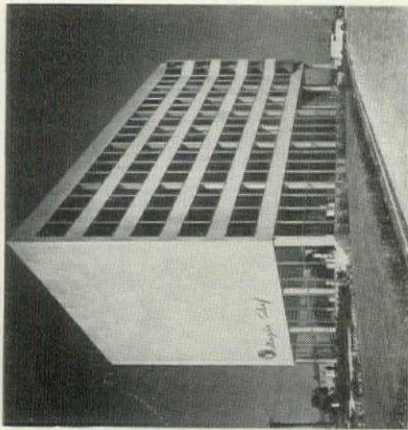

SOUTH

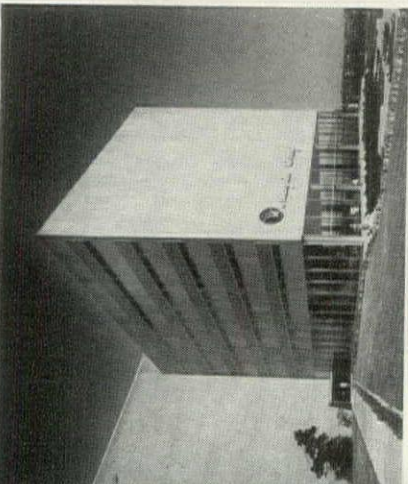

NORTH

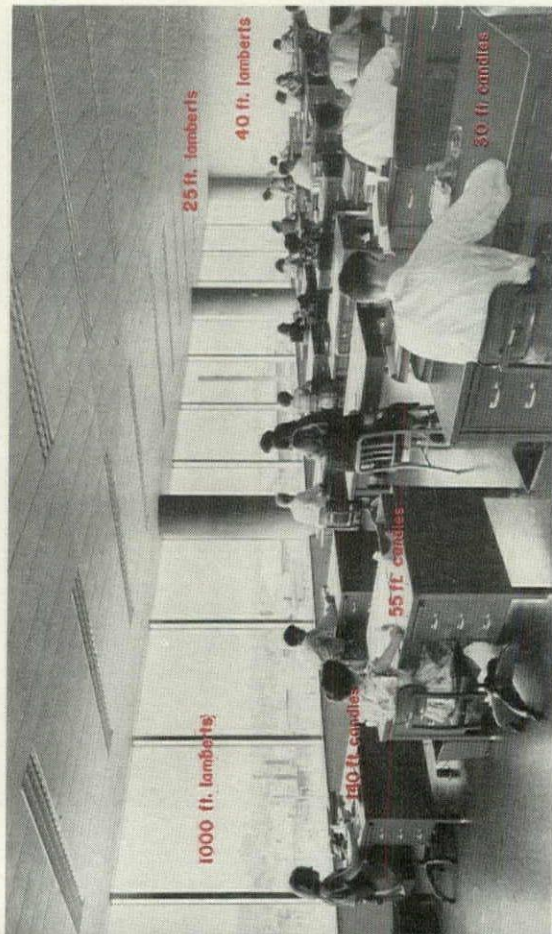

NORTH exposure achieves good result with clear glass. Note readings.

SOUTH exposure is more complicated problem, solved with glass block.

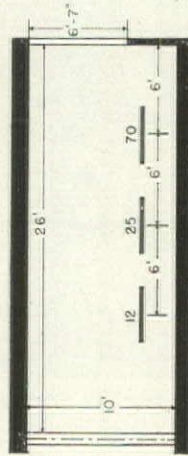
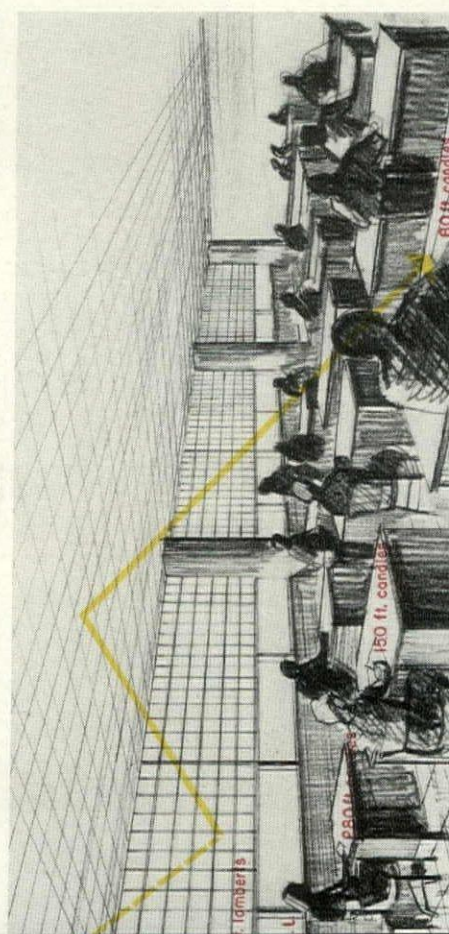

ILLUMINATION in FOOT CANDLES

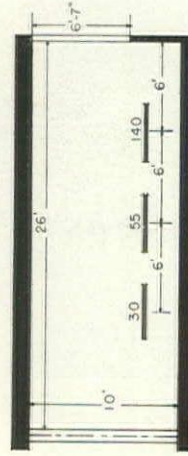

ILLUMINATION in FOOT CANDLES

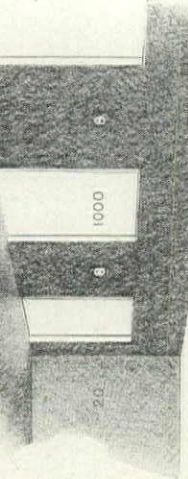

BRIGHTNESS in FOOT LAMBERTS



BRIGHTNESS in FOOT LAMBERTS

light to penetrate to the back of the room, and necessitates artificial lighting there. Designers have utilized directional glass block to control the sun rays. Laid on the south exposure of a building (usually over a clear glass strip window as here) the prismatic block receives the direct sun, but does not transmit it directly. Most of the light is instead bent or refracted to the ceiling, diffused down to provide good natural lighting even in rear areas. This solution, although used with considerable success in recent years, in turn raises additional problems, as detailed in examples of sun pitch below.

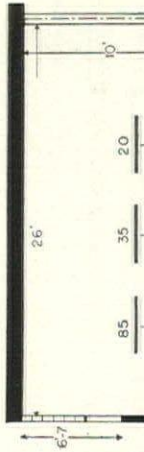
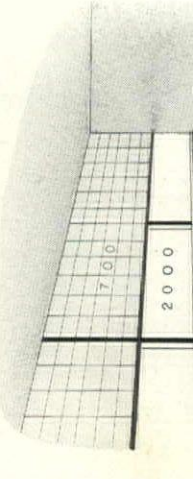

20 DEGREE angle of sun, the representative winter condition, begins to indicate the one problem of glass block, as the brightness of the block itself is seen to increase (see diagrams far right for foot lambert readings) as compared with the "surround"—the walls, ceiling, and sky through clear glass. But these brightness contrasts are still not high enough to be uncomfortable, and glass block does outstanding job of illuminating the rear of the room with natural light.

40 DEGREE angle of sun, condition in part of spring and fall, phrases the problem in glass block usage. Since the glass block does not travel the light directly, as does clear glass, it does hold some light. When the sun is at this angle, office workers on the south side, with their desks arranged in usual right angled pattern, have found the glare annoying, especially to visitors seated at the right of their desks and facing the panels directly, so owners have installed blinds.

60 DEGREE angle, in summer, is again an excellent example of the advantages of glass block. Although sun is at brightest, blinds are not necessary, and lighting all through the room is very good, without use of any artificial light. And contrast of the bank of glass block against "surround" is not high enough to cause annoyance. This good performance is typical of the glass block during the greater part of the year.

CONCLUSIONS and criticism reached from close study of this thoughtful approach to the lighting problem should be headed with the essential conclusion that American Stove's design for daylighting is an eminent success. The test is this—and the building passes it outstandingly—office workers do not find it necessary to turn on the lights under any but the most extreme conditions of exterior darkness. The classic north-south solution in orientation has been proved again. The big windows succeed; they admit a great quantity of unmatched natural light all over the rooms, even on the desks far away from the outside walls. On the south side, the use of glass block in the big windows makes this feat possible. Glare of the sun is redirected with entire satisfaction under all but one certain set of climatic conditions. And even this comparatively rare condition is not without its solution. Lighting engineer Bernard F. Greene has worked out a furniture plan, using the typical deep office of the American Stove

Co. Building as an example, demonstrating a simple rearrangement of desks. This places the chairs of both the official sitter at each desk and any visitor he might be interviewing at such an angle that the glass block panel should not be annoying even at the critical periods of the year. The simple system of plotting the angle of each desk starts with the drawing of a line from the spot where the desk should be (for traffic reasons) to end of the glass block panel. Short axis of desk is then placed at 45° angle to this guide line. Worker and visitor sit in conventional relationship and neither faces glass block, while both enjoy the benefits of the natural daylighting system made possible by the glass block. Even this arrangement, it should be repeated, is necessary only a small part of the year, though it might well be standard practice—as in desk arrangement in schoolrooms—especially for office workers so used to the usual dim lighting that any healthy portion of daylight comes as a painful shock.

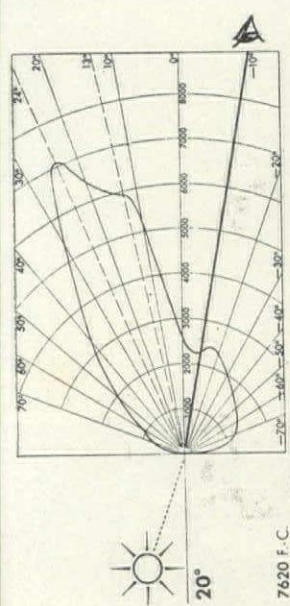

7620 F.C.

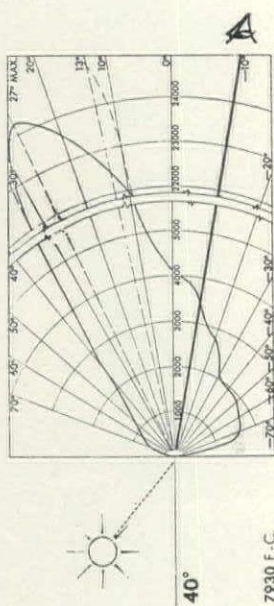

7930 F.C.

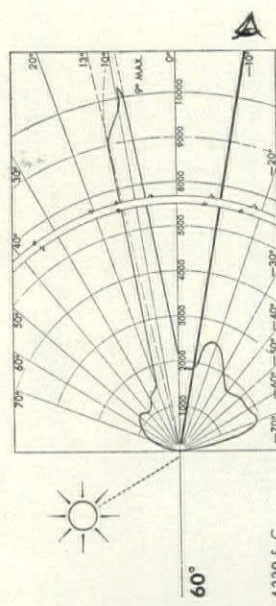

6330 F.C.

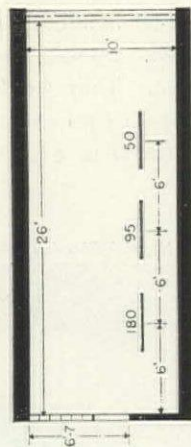

ILLUMINATION in FOOT CANDLES

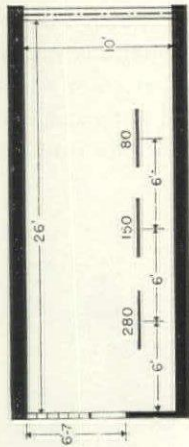

ILLUMINATION in FOOT CANDLES

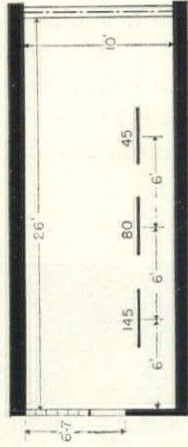

ILLUMINATION in FOOT CANDLES

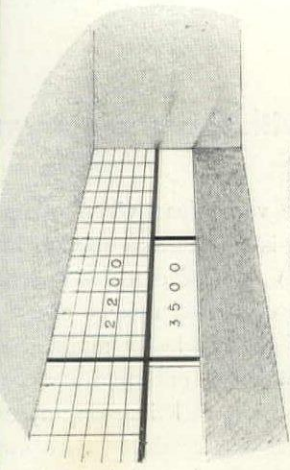

BRIGHTNESS in FOOT LAMBERTS

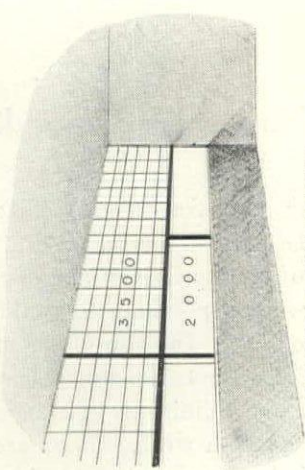

BRIGHTNESS in FOOT LAMBERTS

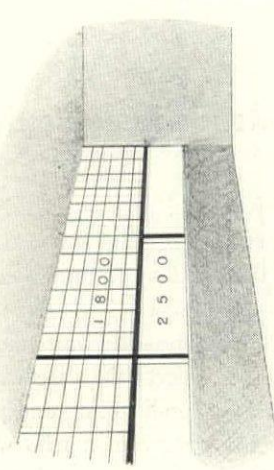

BRIGHTNESS in FOOT LAMBERTS

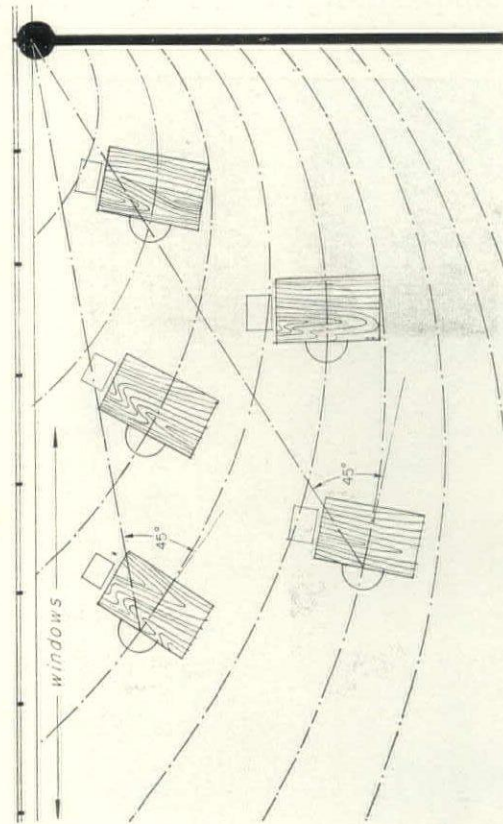

Simple design and costly finishes are intended to give this building a long clean life with few maintenance

Interiors and details of this building show determination to achieve very clean visual planes and surfaces. A good example is the elevator shown at left, which is not a stock model, but was designed by the architect. Use of quality finishes and materials was emphasized in specifications. Extra initial cost was not avoided, providing it would mean decreased upkeep costs in years to come—an investment in economy. The size of the staff of the flawlessly maintained building reflects the ease with which it is kept: the maintenance crew is but one man for electrical, air conditioning and plumbing; the building superintendent has three full time employees with two charwomen who work five nights a week. Floors are waxed and cleaned by an outside contractor once each month; windows are washed outside once a month and inside once each three months. When the architects were designing the parapet of the building they wisely called in that window washing company which would in all probability be handling this job and asked advice on the exact type of apparatus which should be provided. Spokesmen of the company volunteered the interesting information that none would be best. They would wash the windows using their own rigging, and at the same price as with permanent equipment owned by American Stove. Saving in money by this forethought was from \$10,000 to \$12,000.



GLASS BLOCK ENDS ELEVATOR HALLS

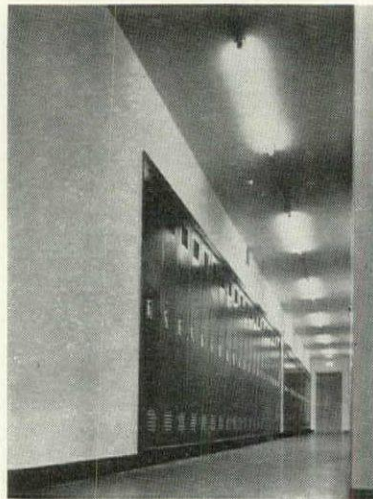

LOCKERS ARE BUILT INTO HALL WALL OF SERVICE WING; WASHROOMS ARE SPACIOUS

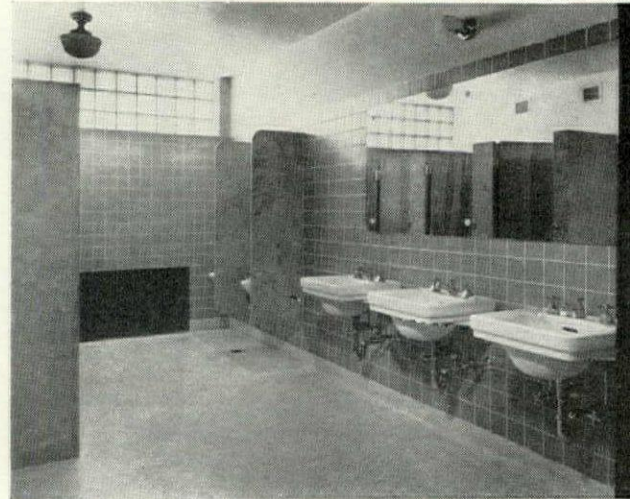

ON UPPER FLOORS INTRODUCTION OF CONDITIONED AIR IS THROUGH PLENUM CEILING

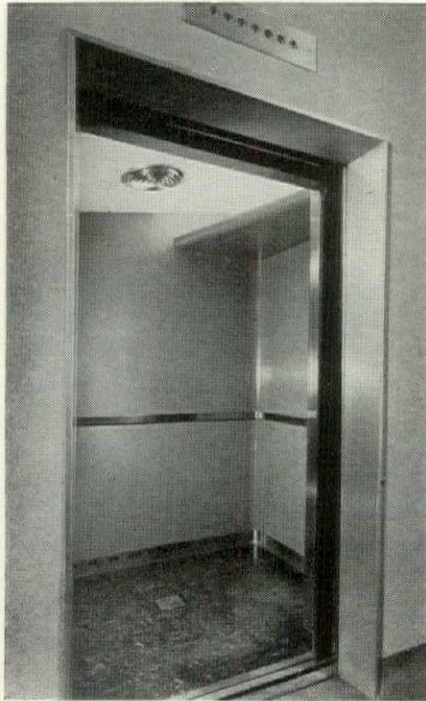

CABS, DOORS ARE SPECIAL DESIGNS

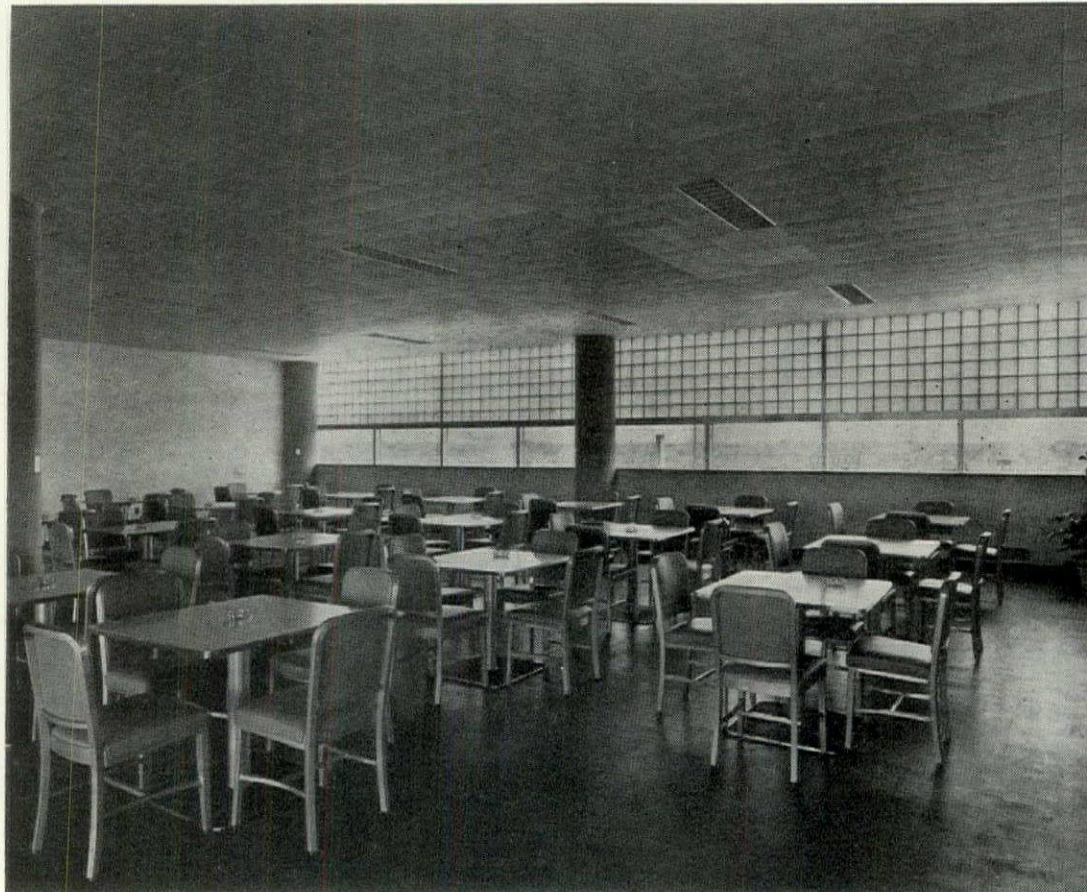

ries and long-run savings

CONSTRUCTION OUTLINE: Foundation—reinforced steel, Laclede Steel Co.; cement—Missouri Portland Cement Co. Waterproofing—Ruberoid Co. Mortarproofing and floor hardner—Master Builders Co. **STRUCTURE:** Exterior walls—Indiana Limestone Co., Haydite Co., Hydraulic Brick Co. Interior partitions—U. S. Gypsum Co. and Centainteed Products Co. Metal lath—Alabama Metal Lath Co. Floor—asphalt tile, Armstrong Cork Co. **ROOF**—built-up tar and gravel, Ruberoid Co. over Zonolite Co. insulation. **SHEET METAL WORK:** Flashing—copper, Chase Brass & Copper Co. and Wasco Flashing Co. **SOUND INSULATION**—National Gypsum Co. and Keasbey-Mattison Co. **WINDOWS:** Sash—aluminum, Flour City Ornamental Iron Co. Glass—Libbey-Owens-Ford Glass Co. Glass blocks—American Structural Products Co. Corrugated glass partitions—Mississippi Glass Co.

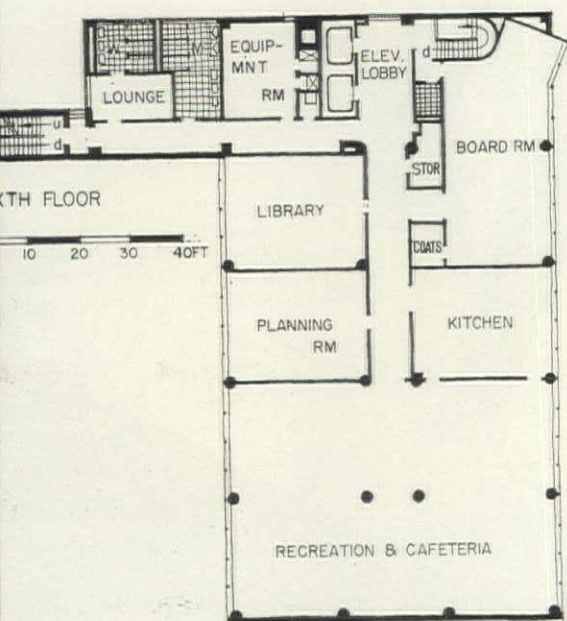

ELEVATORS—Houghton Elevator Co. **FLOOR COVERINGS:** Asphalt tile—Armstrong Cork Co. Carpets (offices)—Lees-Cochrane, Inc. **WALL COVERINGS:** Offices and director's room—Flexwood, U. S. Plywood Corp. Utility rooms—glazed block, Arketex Tile Co. **FURNISHINGS:** Metal furniture—General Fireproofing Co. Chairs, Charles Eames and Harris Armstrong. Curtain—American Stove Co. design executed by Frannie Dressel. Couch fabric—Dan Cooper. **METAL TRIM**—enameled steel, Jamestown Metal Co. and Niedringhaus Metal Products Co. Doors—tempered glass, Tuf-Flex, Libbey-Owens-Ford Glass Co. **HARDWARE**—Schlage Lock Co., McKinney Mfg. Co., Oscar C. Rixson Co., L.C.N. Door Closer Co. **PAINTS**—Pittsburgh Plate Glass Co. and National Lead Co. **ELECTRICAL INSTALLATIONS:** Wiring—rigid conduit, National Products Co. Fixtures—Day Brite Mfg. Co. **PLUMBING FIXTURES**—American Radiator-Standard Sanitary Corp. Cabinets—Charles Parker Co. Valves—Sloan Valve Co. Copper pipe and fittings—Chase Brass & Copper Co. **HEATING AND AIR CONDITIONING:** Air filters—American Air Filter Co. Boilers—Kewanee Boiler Co. **SPECIAL EQUIPMENT:** Vault doors—Herring-Hall-Marvin. Metal lockers—Lyon Metal Products Co. Drinking foundations—Halsey W. Taylor. Water cooler and compressor—General Electric Co. Intercommunicating system—Tele-Talk, Western Electric Co.

THE CAST



W. G. Gamble, chairman of the board of Gamble Construction Co., builders of American Stove Co. building; P. T. George, Secretary; Alan P. Gamble, president; and R. F. Weinberger, job building superintendent



Chief assistant Peter Koscher and Harris Armstrong examine model of the lobby's illuminating ceiling



*Structural engineer
Neil Campbell*



*Designers of air-conditioning system
Allan F. Ferris and Louis C. Hamig*

*... by sculptor
Isamu Noguchi*



American Stove Co. officers George P. Eichelsbach Jr., director of manufacturing, John J. Fendya, Chief engineer, Arthur Stockstrom, President, and George E. Baker, Treasurer





GREENE and GREENE

The American house owes simplicity and clarity to two almost-forgotten brothers who showed us how to build with wood. Their turn-of-the-century work is described in this illuminating study by Jean Murray Bangs, part of her forthcoming book.

In California, at the turn of the century, a wide and benign influence in the development of the American house made its appearance. This was the work of Charles and Henry Greene, two brothers who designed some of the best houses this country has ever seen. But when the California chapter of the A.I.A. last year gave a special Award of Honor to the Greene brothers, scarcely more than a handful of U. S. architects could have said who they were or what they had done.

The work which gave shape and grace to the widely built California Bungalow, which showed Americans how to employ their favorite building material, wood, with great honesty and vitality, had been completely overlooked by the professional schools and the architectural history books. Most of the Greene houses were built in the twenty years between 1894 and 1914, a prosperous, secure and expansive period in American life brought to an abrupt close by World War I. When the terrible new forces of the twentieth century closed down on U. S. society, the assured and cultivated class which had been the market for this simple and craftsmanslike building seems to have been swallowed up by a market more in need of the pretensions of eclecticism.

Unlike Louis Sullivan, the Greene brothers evidently recognized rather quickly that the serene way of life for which their buildings constituted a peculiarly appropriate form had come to an end. They quietly withdrew from practice shortly after the war and have lived in retirement in California ever since. When recognition by their profession finally came to them last year, it found them in their mid-seventies, almost incredulous that the most advanced contemporary architects should now claim them as spiritual ancestors.

Jean Murray Bangs (Mrs. Harwell Hamilton Harris) here tells the story of the Greene brothers for the first time. Digging through dusty files of old negatives (and the equally dusty memories of aged photographers), drawing on her own rich sense of our American culture, Miss Bangs has produced an illuminating study of the Greene's great contribution to our domestic architecture.

To explore all the forces which came to such a rewarding constellation in Greene & Greene's work is a job that must be left to some historian in love with the last golden years of the nineteenth century. It would be a rich and tangled pattern, big enough to include the William Morris and "manual arts" rebellion, burnt-wood pictures and Gilbert & Sullivan as well as the first appearance of Japanese prints, the drift of the bungalow back from the British Colonies, the heady draught of suffragism which must have assisted the housewife in finally expressing her household needs, the great

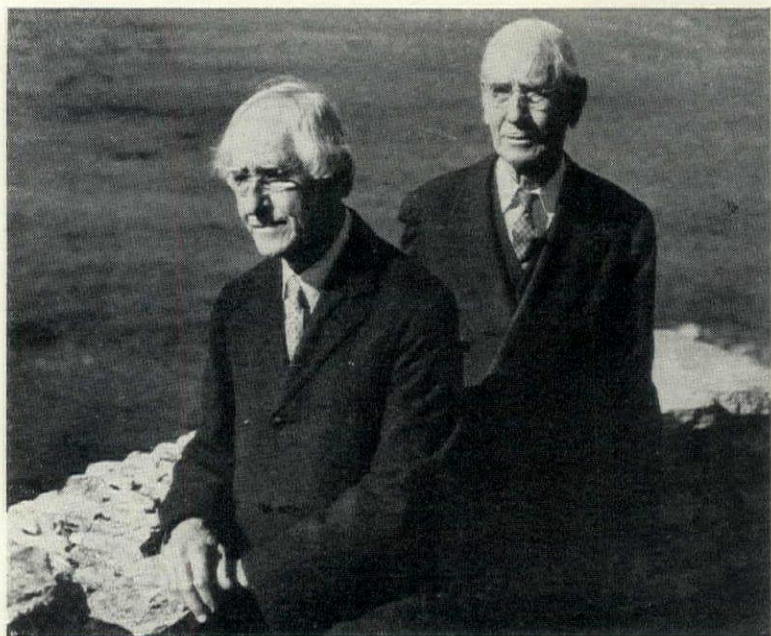

Cole Weston (1947)

democratic American passion that culminated in the Wilsonian freedoms. All this was part of the invigorating air of the period in which the roots of our native American architecture are to be found. In this period, the Greenes now take their proper place, somewhere near Sullivan and Wright.—Ed.

THE last years of the nineteenth century and the first years of the twentieth witnessed the development of an American architecture which expressed the representative and original elements of our culture in contrast to the colonial and imported ones. Starting with the work of the Chicago School, this movement spread to the rest of the country, particularly to the West Coast.

In California it included the work of two distinguished architects, Charles Sumner Greene and Henry Mather Greene. Working mainly in the residential field, Greene & Greene produced well integrated work of high quality which showed a consistent development. Copies of it, known as the California Bungalow, became the characteristic manner of design prevailing in Southern California and were widely built in other parts of the country as well.

This period, which might be called the flowering of American architecture, was followed by twenty arid years, beginning with the resurgence of eclecticism and ending with the bankruptcy of doctrinaire functionalism. During this time, it was only here and there, particularly on the West Coast, that the native American tradition was kept alive. Seeing some evidence of this work in the region around San Francisco Bay, the eminent architectural critic, Lewis Mumford, called it "the Bay Region Style."

This term is a misleading one. It names the whole from the part. This tends to obscure the origin and extent of the work, of which that around San Francisco Bay is only a fragment—although a delightful one. In addition it makes a misleading use of the word style. Style in a particular building is the effect produced by complete integration. Style in the historical sense is "the characteristic method of design which prevails at a given time or place." Using the word in either sense there is no such thing as a "Bay Region Style." Great as are the merits of the work around San Francisco Bay, complete integration is not one of them. Few men there have produced even one building, such as Maybeck's Christian Science Church in Berkeley, sufficiently integrated to warrant the use of the term style. None of them, not even Maybeck, can be credited with such a system of work. Furthermore, by no stretch of the imagination can it be said that the work proclaimed by Mumford as "the Bay

← Beam ends extend beyond eaves of Blacker house, their 1907 copper caps gleaming still in the sun
Maynard Parker (1947)

Region Style" was ever either the characteristic or prevailing method of building around San Francisco Bay.

If Mumford was in search of a regional style, he missed it by about five hundred miles. Such a style can only be credited to Greene & Greene.

When the Greene brothers opened their office in Pasadena in 1894, they were fresh from training in the principles of classic architecture at M.I.T. There was little enough in their background to suggest that they would break with the Classic Revival in which they, like every other educated architect of the period, had been steeped. Born 15 months apart in St. Louis in the 1870's, they had the secure childhood that was the rule in middle-class families of the time, typically including summers on their grandfather's farm. The Greene family, from Rhode Island, had an imposing list of Revolutionary ancestors, among them, General Nathaniel Greene.

Only one early clue to their later work is apparent. This was their enrollment at the Manual Training High School operated by Washington University in St. Louis. This was one of the progressive schools of its day, an early effort to make education technical instead of literary. Two hours of manual training a day had been added to the academic curriculum. The first year, the students studied carpentry; the second, blacksmithing and metal work; the third, they made tools for the machine shop, learned how to temper them, how to operate the lathes and machines. It was a sound introduction to architecture, and it is probably not too much to say that the wood-working techniques taught in the manual arts classes laid the groundwork for the loving and highly conscious exploitation of this material which characterized Greene & Greene work. Certainly training in the handling of craft tools proved immensely valuable to the architects who, because of their new way of designing, had to teach everyone who worked for them how to build.

While they were carefully running Chinese ink washes over the classic orders at M.I.T., they were introduced by a socially well-connected aunt in Newburyport to the wife of the college president. At her evenings-at-home the young brothers got their first breath of an elegant world, where serious conversation was graced by wit and assurance. Here they unwittingly prepared themselves for talking easily to the wealthy families who were to become their clients.

For two years after their graduation from M.I.T., the brothers worked for Boston firms: Charles for Winslow & Weathersell; Henry for Chamberlin & Austin and for Shepley, Rutan & Coolidge. Then they went to California to visit their parents and decided to start practice in Pasadena, then becoming the winter resort of wealthy families from the East and Middlewest.

The complete inapplicability of the Classic Revival style in which the Greenes had been educated to the California climate was, of course, immediately apparent to them. Nor did they find much in California to help them. But they seem to have recognized almost at once that the new life growing up in California called for a new

architecture. Their whole professional life became a prolonged and conscious effort to create a house suited to the country, the climate and the life in which they found themselves. By 1907 they had met success.

If the Neo-Classic house seemed even less appropriate in the warm sunshine of California than it had in northern city streets, it also failed to express the new and distinctively American attitudes which were beginning to emerge.

There has always been a dualism in American life. Two attitudes have existed side by side: one an extension of the beliefs and standards of the past; the other the expression of native and original values. Greene & Greene clients represented the latter attitude. Leaders of industrial America, owners of fortunes in oil, lumber, mines, in soap and glass, they were the people in whom distinctively American attitudes were most clearly expressed. Now, self-assured and secure, they began to demand houses which were an expression of their life.

The first houses of the California pioneers had duplicated the traditional American houses of the forties. After the Civil War a new type emerged. It was a large house, well built, pleasant to live in. However, it was notable for a variety of architectural features such as towers, cupolas and bays, and embellished by a variety of jigsaw

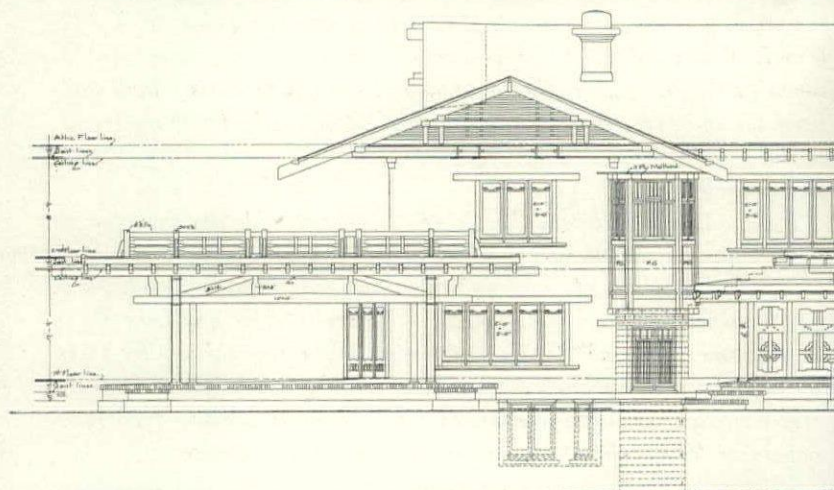
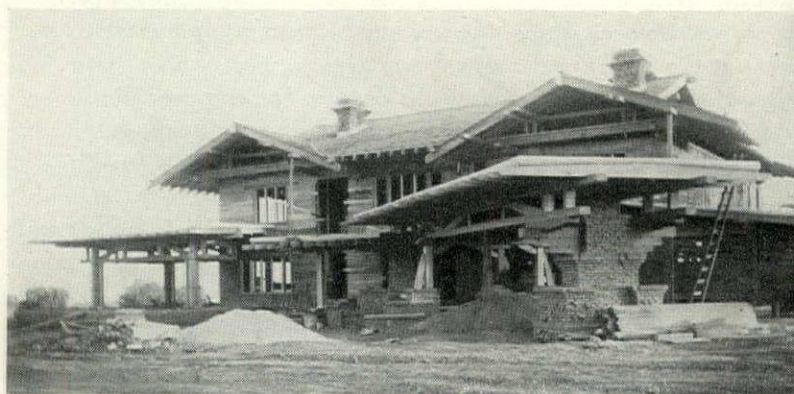

Leroy Hulbert (1908): Copy by Merge Studios

The Blacker house and garden (1907) shows how the house blended with grounds in shapes and textures, while its large and loose organization also settled easily into the California horizon. An ideal pattern of living developed out of this integration of structure and land. The bold angle of the porte cochere is noteworthy; it shows that the Greene brothers knew how to dramatize as well as to express structure.

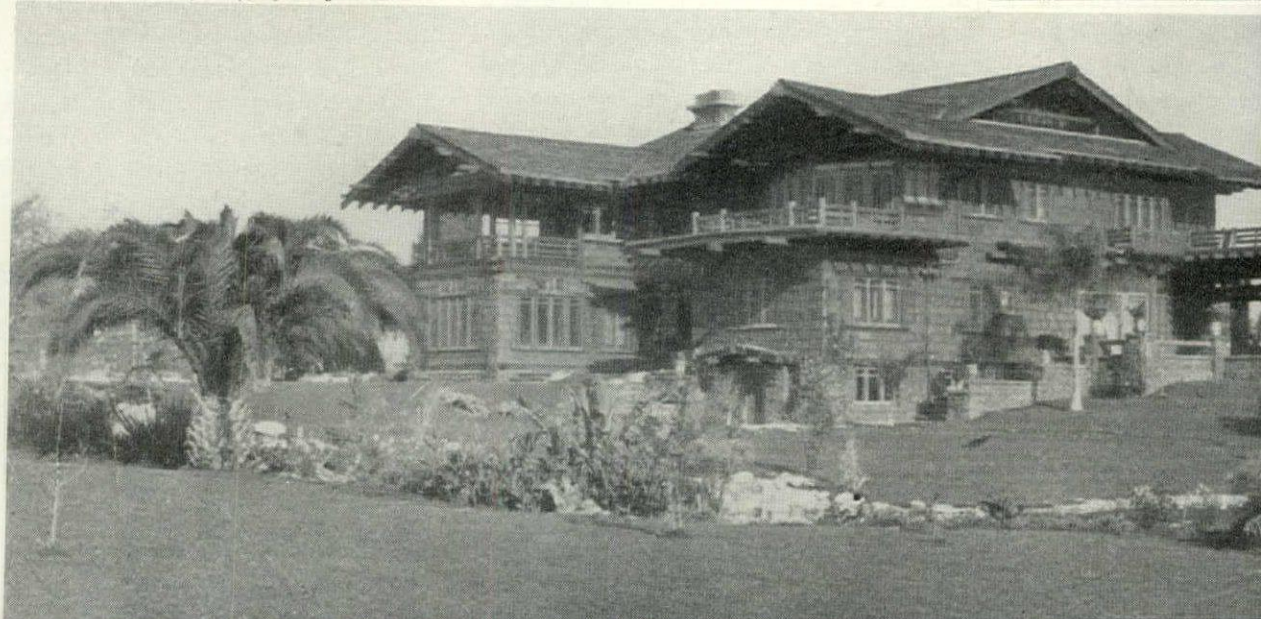

ornament. It has been the fashion to sneer at these buildings. They have been laughed at as the epitome of all bad taste. But we are now beginning to look at them in a different way, to see in these great roomy, hospitable houses the early evidence of an economy of plenty—the naive expression of the wealth, strength, aspiration, exuberance and pride of the men who built them. In the nineties, however, the reaction against them was at its height. Less exuberant, more self-conscious and possessed of a more tutored taste, the new middle-class understood beauty in terms of simplicity, fitness and repose.

But ideas of beauty were not the only ones which were changing. It was a time of intellectual ferment. Scientific attitudes toward health and sanitation were beginning to emerge. New conceptions of the needs and training of children were coming into vogue. The air was full of “advanced ideas” of every sort. The aspiration of the period could be summed up in the word “reform.”

It was in this climate that a new and informal way of living was being developed by the middle-class. Informal and relatively sincere forms of hospitality were coming into vogue. Since the values of family life were the ones most highly prized, the ideal house was conceived of as a place in which the child could develop to the full extent of his powers and which he would remember with pleasure the rest

of his life as “home.”

If architecture were to reflect life, these things were bound to affect the form of the American house. Fortunately some of the architects of the period were able to turn their backs upon the past and accept the challenge of the new times. These were the men who pioneered the new house. Greene & Greene were among them. Their keenness in interpreting the new American needs and attitudes of the time was the basis of “nascent functionalism.”

But Greene & Greene felt another influence which was strong on the West Coast at that time. This was the influence of oriental art. Almost as soon as Japan was opened in the early fifties, an appreciation of its art began to seep into the western world. Edward Morse and Ernest Fellonosa, in the seventies, Perceval Lowell, John La Farge and Henry Adams, in the nineties, were only some of the travelers who helped spread an awareness of this art. By the early part of the twentieth century this was so widespread that it had entered the art departments of the public schools through Ernest Dow, who had spent years of study in Japan.

Greene & Greene ran head on into this influence on the Pacific coast. One had only to walk down the street to feel it. There were beautiful Japanese tea gardens in Pasadena and in San Francisco.

Maynard Parker (1947)

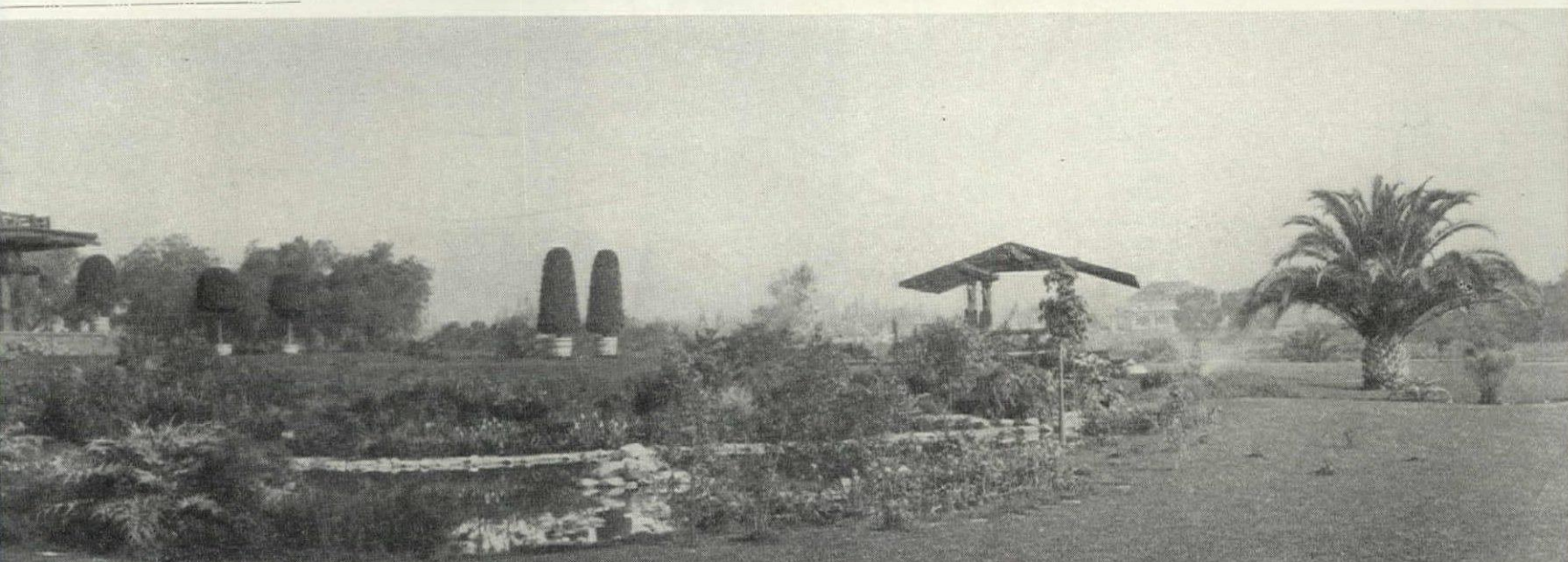
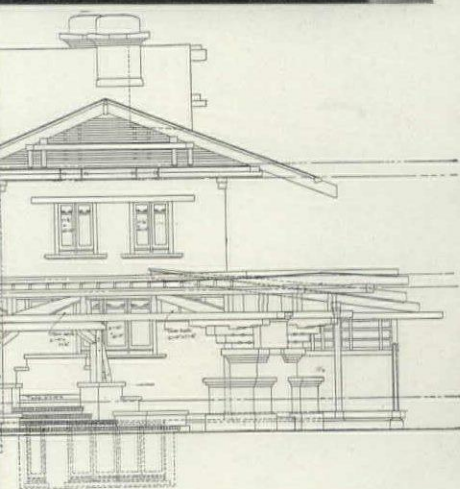

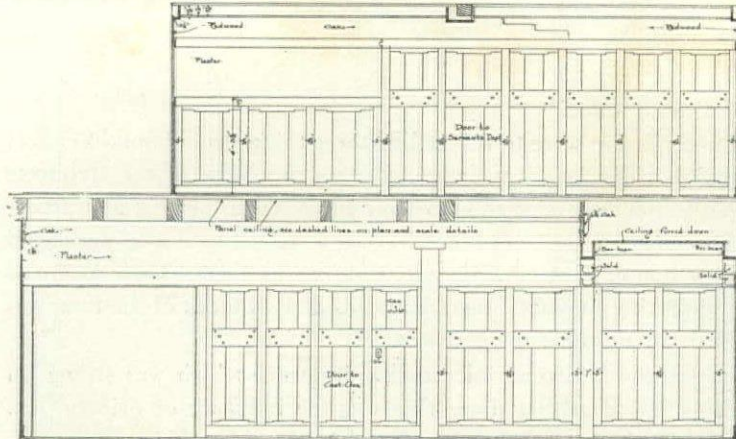

LOOKING WEST

HALF INCH SCALE DETAILS OF HALLS

RESIDENCE FOR

E. B. BLACKER AT OAK KNOLL

GREENE & GREENE ARCHTS 215 BOSTON BLDG PASADENA CAL

SHEET NO 60

OCT 12 '07

NOTE Contractor must verify all measurements at building and is responsible for same.

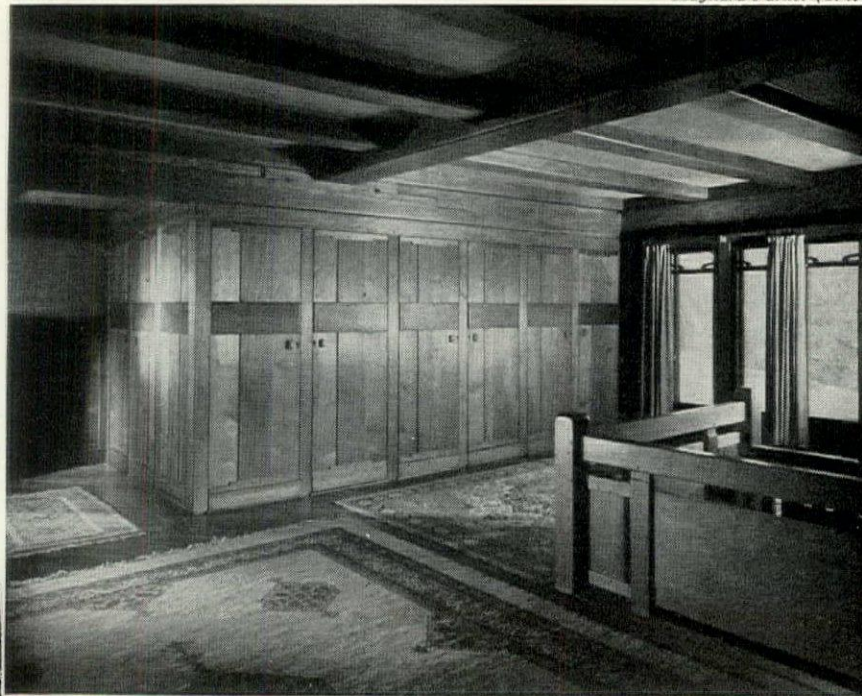

The exposed beaming carried out beyond the roof line in the Blacker house exterior (as shown in pictures on preceding page) becomes a highly decorative part of the interior. Hall panels (above) conceal a storage wall. Stairway rail is a good example of how detailing is consistent in tone with treatment of structure.

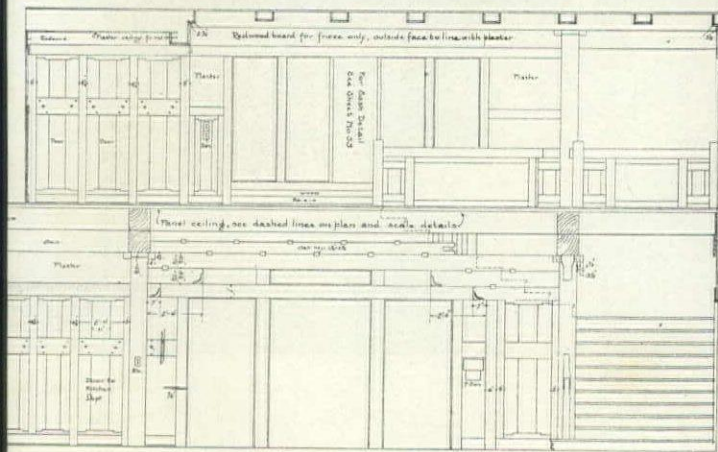
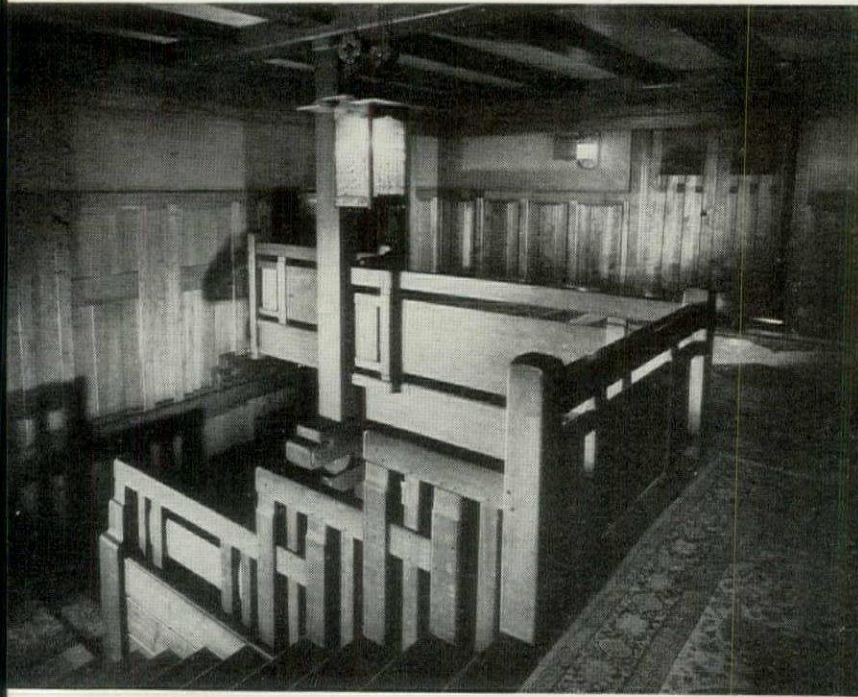

LOOKING NORTH

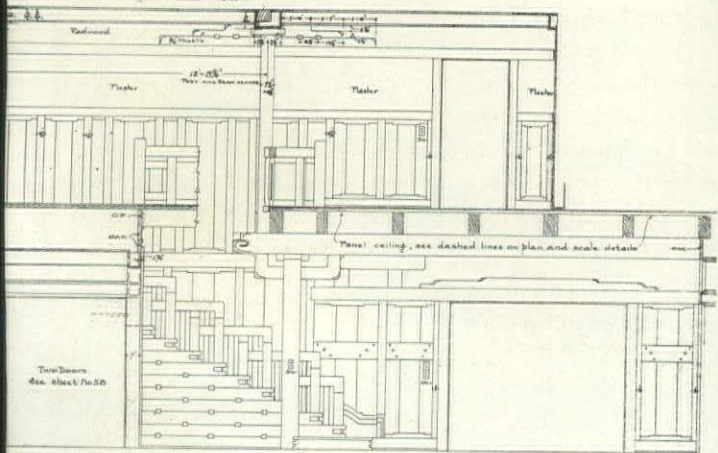

LOOKING EAST

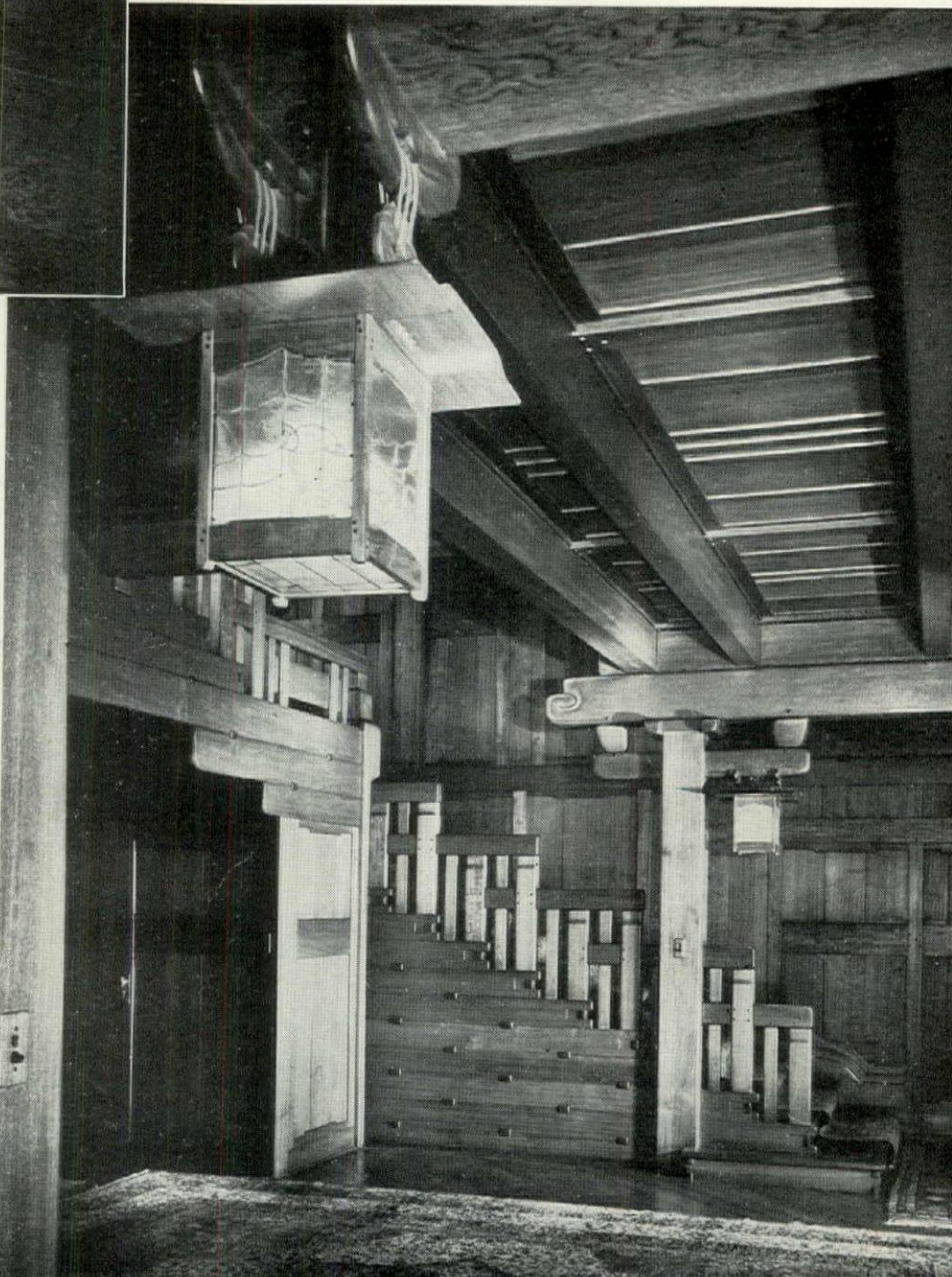

Oriental shops, run by discriminating connoisseurs, were full of objects which would be museum pieces now—objects which represented the loot of the centuries. Morse and others wrote books on the methods of construction in Japan.

The brothers fell under the spell of this art. Their work shows a strong oriental influence. But like Richardson, like Wright, like Maybeck and like all strong men, they made of the sum total of influences they received, something new in the world, something their own. It is one of the pleasures of erudition to pick out the oriental details in the work of Greene & Greene. Unfortunately, like so much of erudition, it leads nowhere.

In their first attempts to design for California, Greene & Greene tried adapting and mixing styles. The five hundred odd sets of plans which make up their work, show clearly the pattern of their early struggles. The drawings show Colonial, Queen Anne, Spanish Mission and an "English type house." Sometimes they mixed all these together along with a few ideas of their own. A study of this work shows conclusively the futility of this method of attack. Creation begins another way.

The development of the real Greene & Greene style began with the Bandini house built in 1903. Mr. Arturo Bandini, scion of an early Spanish California family, came into the office, asking for a "California" house. The plan he had in mind was the one the Spanish have used everywhere in the new world. It consists of a series of rooms strung one room deep around three sides of a hollow square. The rooms are entered through each other, railroad flat style, or through a covered open passage running around the house on the inside of the square—the patio. The traditional material for this kind of house, adobe brick, was not used here. The materials were the simplest ones possible. The walls were board and batten, the roof wood shingle, the foundation and fireplace cobblestones.

It is interesting to know that when Greene & Greene began work, most of the cement used in California was brought from Europe in ships that came around the Horn. The use of cobblestones, a cheap local material, saved the use of the expensive cement. However, the color produced by the stones made an inharmonious note in their compositions. They turned to another cheap local material. This was burned or clinker brick. Mixed with the cobblestones it gave the required color tone to the masonry. This was the origin of the later vogue for these materials, clumsy use of which became known as the "peanut brittle style."

The Possibilities of Wood

The Bandini house had an importance altogether inconsistent with its size or price. It gave Greene & Greene the clue they were looking for in trying to create a California house. Both the plan and the material were admirably suited to the climate and the life. From this plan, the Greene & Greene patio house was developed.

There are some fine examples of their fully developed patio house in Pasadena. These are the Freeman Ford house, now unhappily disfigured by a mission tile roof, and the home built for Cordelia Culbertson and her sisters, better known as the Prentiss house. Both of these are executed in stucco.

From the simple wooden structure of the Bandini house, the brothers set about to explore the structural possibilities offered by the use of wood. Of the typical Greene & Greene wood construction, three of the finest examples are the R. R. Blacker and David B. Gamble houses in Pasadena and the Wm. R. Thorsen house in Berkeley. None of these happens to have the patio plan.

Unfortunately, the Blacker house fell into unsympathetic hands. After Mrs. Blacker's death, the grounds were cut up, the gardener's cottage remodeled and painted, the garage turned into a tasteless house, the furniture sold second-hand. The Gamble house is one of the few great Greene & Greene houses remaining in the hands of the original family. Loved and beautifully kept, it looks much the

same way as it did when it was built. The Thorsen house belongs to the Sigma Phi fraternity at the University of California, where it is recognized as one of the monuments of American architecture. The existence of these three houses alone would be sufficient to establish Greene & Greene as masters in the use of wood.

Until the period of laminated wood, wood was used in the form of the stick and the board. This is the form in which we see it used by Greene & Greene. In their work we are constantly aware of the stick, used as a post, as a beam or composing a lattice, trellis or truss. We see the stick joined together by notch, dowel or strap; the stick making the rhythmic pattern and the joints the decorative detail.

We are aware of the board, wide or thin, joints open or closed, with lap, plain-faced batten or tongue and groove. We see boarding long and narrow; boards parallel or criss-crossing in woven open patterns as in a fence or terrace railing. Or we see the board short and thin, methodically arranged in a textural pattern of partial overlay, as in the large expanses of shake-covered walls.

Since wood is not adapted by nature for flush designs, the Greens did not attempt to form separate pieces of wood into shapes which couldn't easily be maintained after the sun and the rain had had a chance to shrink and twist them. The durability of their structure*



Gamble house (1909) is entered through a translucent wall of wood and stained glass, which at night is a dramatically illuminated approach. Screened flanking panels provide ventilation.

is in a large measure due to the fact that they made no effort to achieve a continuity of line that belies the multiplicity of the parts beneath it. Esthetically this resulted in the broken line and segmental structure, which became a striking feature of Greene & Greene work.

In using a really continuous material like composition sheet roofing, they emphasized this continuity, carrying the wide sheets of Malthoid up one slope and down the other, folding it in a huge roll to form an integral gutter, the tapering roll at the gable becoming one of the details that delight by climaxing the whole structure.

When it became necessary to provide for things like underfloor and attic ventilation, they worked at it until they found a means of doing it beautifully and adequately. They never adopted means which were inefficient or which had to be concealed in order not to

* Greene & Greene are still noted for the excellence of their construction. Pasadena real estate dealers still get calls from buyers wanting Greene & Greene houses because they are so well built.

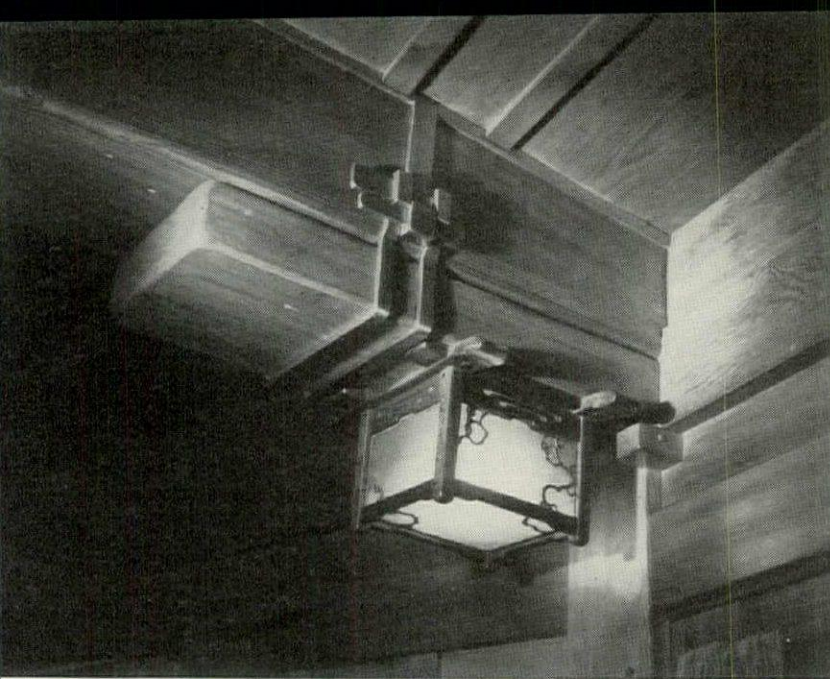

Maynard Parker (1947)

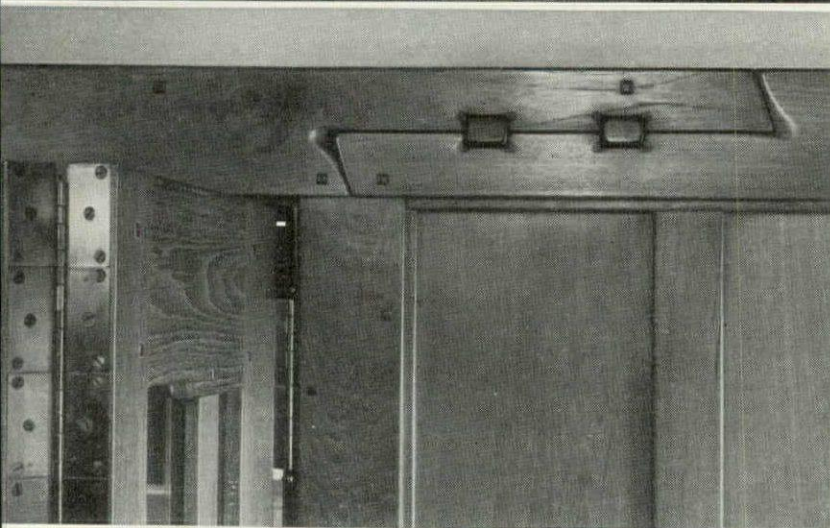

Atmor White (1948)

Clearly articulated joints are beautiful details of both interior and exterior of Greene houses. These are probably related to the carefully expressed wood joinery taught in the "manual arts" classes of the period. Exterior close-up (bottom) shows a sensitive material gradation.

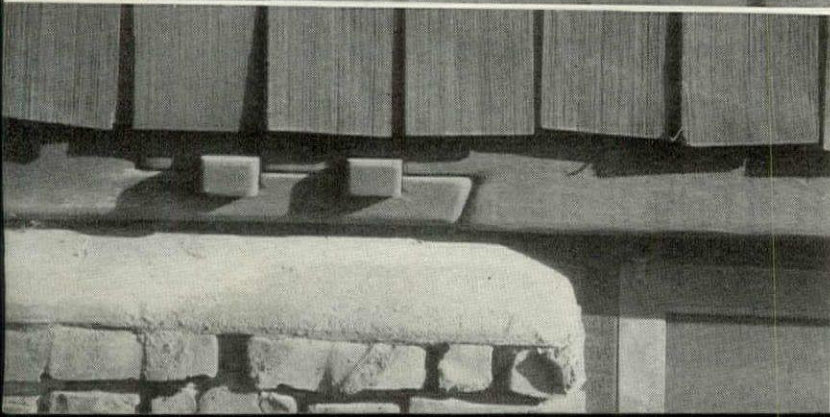
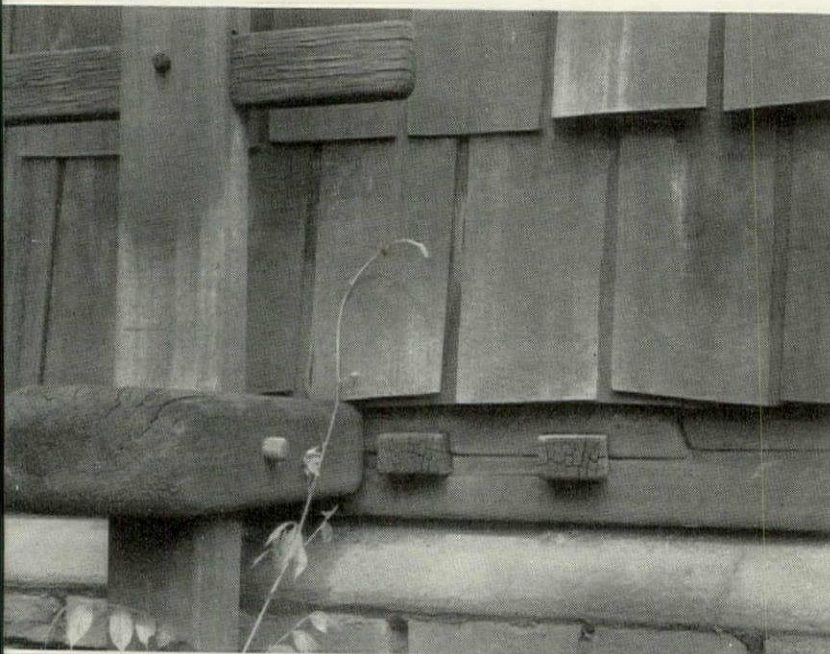

hurt the appearance of the building. As a consequence the overall effect of what they did was generous, natural and unashamed.

In the design of features necessary to the preservation of structure they showed an equal degree of imagination: in the mudsill exposed on the exterior to prevent rot; in the sloping tops and rounded edges of exposed wooden members and in the copper caps used to cover the end grain of the more exposed structural members.

The whole design was unified by a consistent emphasis of structure. The exposed structure became a natural and integral part of the design; so did the exposed wood trusses over the larger spans, the exposed framing, the wooden keys and the metal bands and wedges joining the larger members. The same details were used in the inside and the outside of the house, upstairs and down.

Part of the Landscape

Integrated works of art in themselves, Greene & Greene houses were also integrated with the landscape. In the relatively unsettled California of the early 1900's, houses were still seen against the background of the country instead of merely against a city street.

To blend the houses into the landscape, Greene & Greene designed low spreading roofs which echoed the lines of the hills. The wood shake-covered walls, the cobblestone and brick chimneys, the dotted eave lines made by the projecting rafters were as richly textured as the hills themselves or as the groves of oranges and oaks that dotted the valleys. Stain was used, never paint, and the color of the stain was mixed to blend the structures into the landscape, to harmonize with the hot and tender greens, the grays and brown of the California countryside. Even today, when not disfigured by paint, the houses blend into the planting with a cool and inviting look.

The imaginative flights of Maybeck, his superb handling of historic form; the plastic quality so desired by Wright and the mastery of it which gives his work its characteristic quality, were entirely lacking in the work of Greene & Greene. To a greater degree, however than was achieved by Maybeck, and to as great, if not greater one than was achieved by Wright, Greene & Greene houses were beautifully integrated structures in which the interior and exterior of the house, the furniture and the garden were all parts of one harmonious and beautiful whole.

The difficulties overcome in achieving this result were enormous. Men of lesser caliber, or men less interested in their work, would have been frightened before they began. After Greene & Greene had evolved their philosophy of design, their work had merely begun. They had to train all of their architectural help. They had to teach their contractors how to build. They had to develop their own millmen, wood carvers, stone cutters and workmen of all kinds.

Then when the houses were built there was no furniture suitable for them. So the brothers were obliged to design furniture and have it made under their supervision. They designed glass, carpets, lighting fixtures, and even in one instance a piano case.

They could no more find landscape architects capable of grasping their ideas and carrying them out than they had been able to find decorators. Thus they were forced to plan their own gardens. Because landscape architecture is before everything else an art of design, this was not difficult. They depended on a Scotch gardener named Chisholm, to help them in the detail of growing plants.

The result of all this was a style which was distinctively their own, a whole in which the house, garden and furniture all bore the imprint of the Greene & Greene mind.

They were able to achieve this synthesis because they were able to do what few architects have been able to do, either before or since. They worked out a system by which they were able to control the whole process of design and building from start to finish—from the first sketch to the last detail of the completed work.

In this they had one great natural advantage. There were two of them. What architect has not at one time or another felt the urgent need to be twins? Although Henry Greene was 15 months younger

than his brother Charles, both had had the same architectural experience from the very start of their professional life.

There was a theory current among their contemporaries that Charles was the artist and Henry the business man. A study of the houses each designed separately does not bear this out. Both men were artists. If the business was left to Henry, he was able to handle it satisfactorily only because he was artist as well as business man. So well did they work together that Greene & Greene were, to all intents and purposes, one man.

A fortunate circumstance of the time helped them control their design. Greene & Greene clients did not have to borrow money with which to build. Therefore the problem was set by the conditions of the work itself and not, as is so often the case at present, by the arbitrary demands of a lending agency. Since one of the basic elements in any design is the correct statement of the problem, this freedom from outside control was a great advantage. Greene & Greene were not hampered by having the problem set for them in advance, nor did they have to contend with the interference of arturies when their design was finished.

But most important for the successful consummation of their work was the control they exercised over construction. No contractor who did a bad job was ever employed a second time. Gradually more and more of their jobs began to go to a young Scandinavian—Peter Hall. Finally they were instrumental in setting him up in his own mill. At the height of their career Hall worked for no one else. All the interior woodwork in Greene & Greene houses, as well as the furniture, was made under Greene & Greene supervision in Peter Hall's mill. Every morning Charles Greene came down to look at the work, and the workmen took orders from him. As worked out by these three men, this was a wonderful system.

There was still another aspect of their work which strikingly anticipated the basis of contemporary architecture. They recognized that their houses must not only be harmonious and consistent, but practical to use and maintain as well. In their efforts to achieve this, Greene & Greene consulted the women whose workshops these houses were to be. On the basis of these consultations they designed sinks and cupboard space and all kinds of kitchen equipment. They raised the height of kitchen counters from the 2½ ft. then customary to 3, to make a more convenient working height. They devised systems for arranging clothes in closets. Nothing was forgotten.

Their careful study of function was responsible for many modern elements in their plans. They were among the first to turn the house away from the street. Always conventional looking on the street side, almost every house has either a patio or a sheltered back garden in close connection with the living room. The Culbertson house plan (p. 39) shows how this inward opening, in this case extended all along the bedroom wing by means of a luxurious gallery, grew easily out of the patio plan. Some may find their rows of glass doors, in a favorable climate, superior to the large fixed glass areas often favored by contemporary

architects. In its clear-cut grouping of function—living-dining, service, sleeping areas, guest wing—this plan has a very modern look.

The Blacker house, built in 1907, contains a storage wall, sectional furniture (designed by the architects), built-in furniture, a two-purpose room divided by a sectional glass wall which can be folded out of the way. It has modern fenestration, and facilities for outdoor living which can be equalled in few houses today. Its eaves are designed to shut out the sun in summer and let it in in the winter. It faces the sun and away from the street.

In the Cordelia Culbertson house (1911) the glass wall of the garden room can be made to disappear above the ceiling through the simple expedient of a hollow parapet wall and adequate counterbalances. In the Thorsen house (1908) and the Crowe house (1914) designed by Henry M. Greene, there are large flush panel ceiling lights. The Crowe house has a long gallery on the south, one side of which is constructed almost entirely of glass.

Each bedroom in the Gamble house (1909) is double, consisting of one inside and one outside room, the latter having the old-fashioned name of sleeping porch, just as on the plans the garage bore the old-fashioned name of auto barn.

If the Greene & Greene houses were friendly, unostentatious and

Leroy Hulbert (circa 1910): Copy by Merga Studios

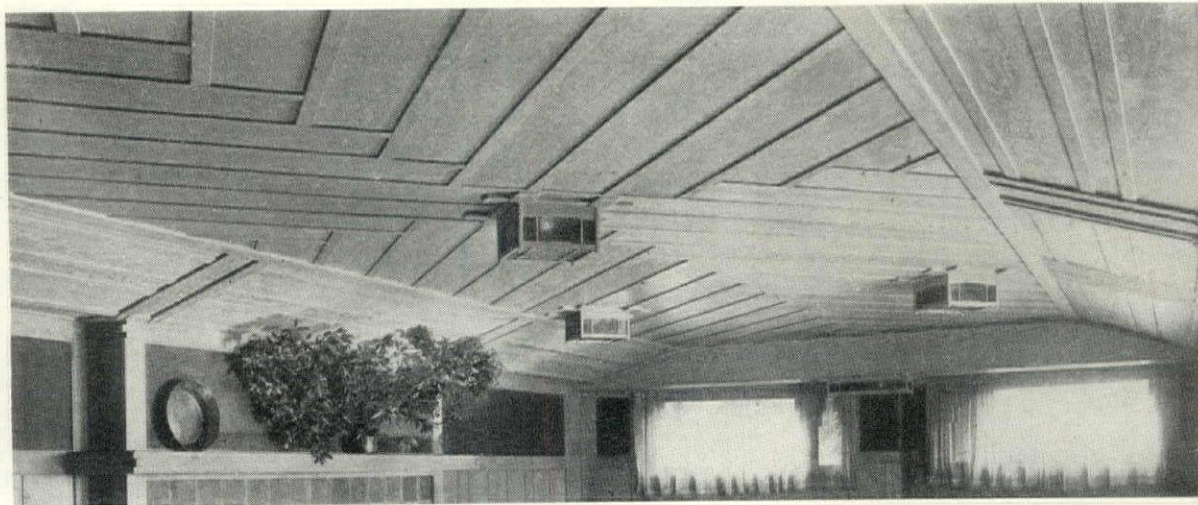

Thorsen house (1908) had a large basement game room, in which a gracefully patterned wood ceiling is the main decorative element. Pratt house (1909) shows living room glass wall opening wide to sheltered inside terrace. Cabinet-desk was Greene-designed to fit wall section.

Maynard Parker (1947)

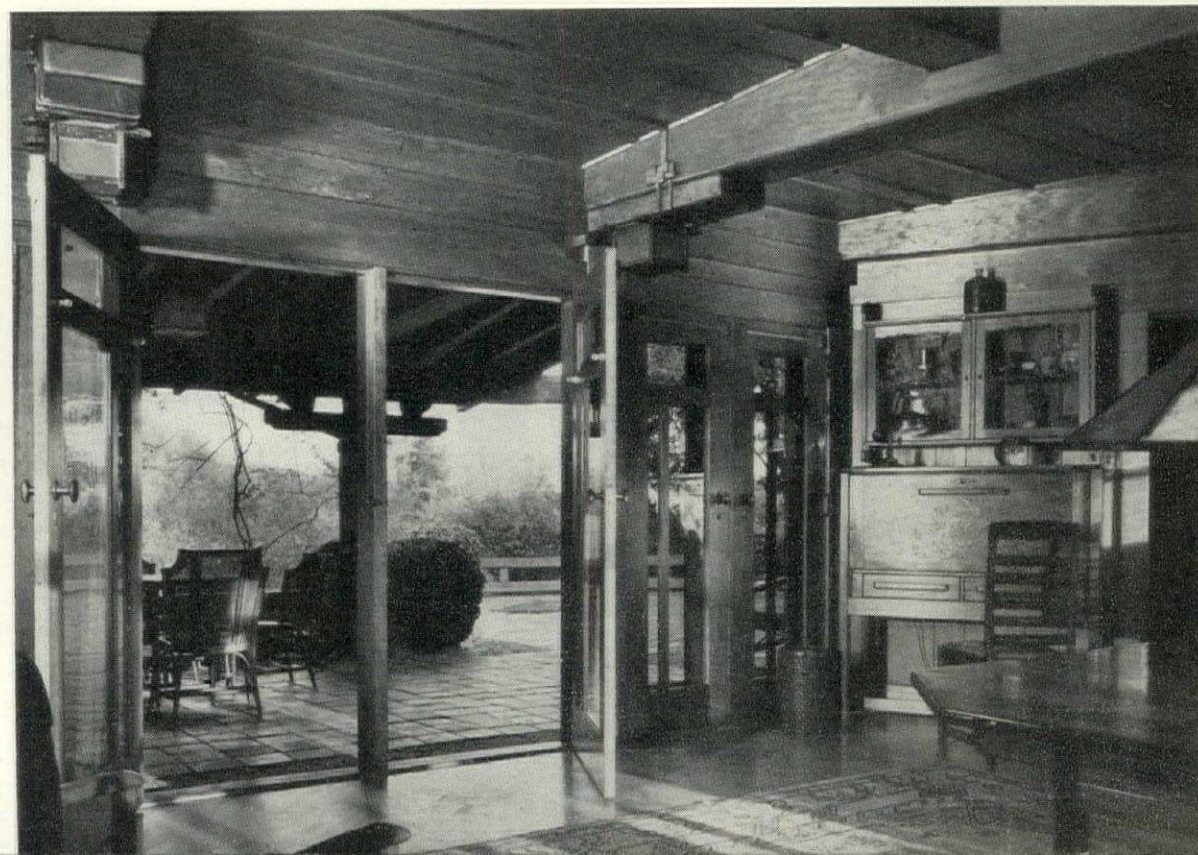

among the first really comfortable houses ever built in the U. S., they also met the requirements of a democratic art in another important way. The same style was used for both big and little houses. It was equally adapted to both. While many, especially the later, Greene & Greene houses were large and expensive it could not be said that the architects designed only for the well-to-do. Rather they created the type form from which sprang the most delightful little houses we have ever had.

In a basic way, the Greene & Greene house put design back into the hand of the people. The little men, the small carpenter-contractor-builders, the men who have built most of our small houses, understood Greene & Greene work and could imitate it. This was because it was based on structure which they could understand.

Give such a man historic form to handle, face him with the problem of making a house in the style of an Andalusian cow shed (which was one of the problems the architectural profession in Southern California set for itself) and he is lost.

Set him to imitating the plastic form of Frank Lloyd Wright and the results are a caricature. One realizes then, if not before, that it takes a real designer to handle this form.

The little man should stick to structure. He is on his own ground. He is safer there. With such superlative models as those offered by the work of Greene & Greene, he could hardly help from doing something good. Books might be filled with pictures of the spontaneous variations that these men played on the bungalow theme.

But this work finally deteriorated. With no new models coming up, the builders resorted to copying themselves. They took their ideas, not from the source but from "Ye Planry Co.," "Wilson's Bungalow Book" and dozens of the same variety. The situation was analogous to the language situation in the New York slums, in which the newcomers learned English, not from those who spoke it correctly, but from the broken English of earlier immigrants. Such a situation is as fatal to good works as to good words.

If the work of Greene & Greene had been taken into the architectural schools, where it would have served to inspire the young creative minds in architecture—those capable of working in the same spirit—this honest tradition might have been carried on. The original work would have been re-created by the talent of each suc-

The Pratt house is an harmonious addition to an unspoiled landscape. The broken roof, projecting eaves, and low-slung structure seem to grow out of the natural projections of the land.



ceeding generation. The contractor variation of the house, which like folk art is not creative in itself, would have reflected a constantly changing and developing design. There would have been constant interchange between building at the higher and at the lower end, to the advantage of both and the enrichment of popular taste.

The appearance of so many bad copies of their work is one reason why Greene & Greene's own practice fell off after 1914. As the reflected images of the Greene houses became increasingly debased, people tired of them. They forgot the beauty of the original ones. Moreover, while their price seems almost nothing to us now, the great Greene & Greene houses were expensive for their day. When Pasadena ceased to be a fashionable winter resort, the supply of millionaires gave out. On top of that, rising prices made it doubly hard for architects like Greene & Greene who had become used to thinking in terms of quality, rather than price.

Water from One Well

The work itself was lost to sight for other reasons. One of these was a situation peculiar to Los Angeles itself. After the first World War, Southern California was inundated by one of the great waves of population in which it is periodically engulfed. The newcomers were oblivious to the synthesis which was here. The same thing had happened in Chicago after the World's Fair in 1893. In Southern California, it was the 1915 Exposition in San Diego and Bertram Goodhue's Spanish colonial—plus the influx of "good taste" from the East—which did the trick.

For a decade the American tradition exemplified by Greene & Greene was smothered under clumsy efforts to adapt monumental buildings to domestic use and a futile effort to find a mediterranean prototype for the American house. On top of these confusions came the powerful propaganda of protagonists of the International Style. None of this would have been successful in obscuring the influence of Greene & Greene, if it had not been for one thing. Like its counterpart—secession architecture in Europe, work in the American tradition was in conflict with the ideas of the architectural profession of the time. As a result it was kept out of the schools, ignored by the critics and undocumented. This is why we have such startling gaps in the documentation of American architecture—gaps which include the work of men like Greene & Greene, Maybeck and others.

Now, as we leave behind the colonial cultural attitudes which have persisted in this country for so long, we are beginning to appreciate the work which represents the indigenous cultural elements of America. Since the ideas and ideals of the nineteenth century middle-class mind are a direct outgrowth of the ideological base on which this country was founded, any work which gives them a clear and powerful expression seems bound to persist. To borrow Gideon's phraseology, it is one of the constituent facts of its time.

Thus it was inevitable that when the force of the propaganda for imported style had spent itself, public attention would again be focussed on the Greene work. It was part of a cultural movement which found expression in every aspect of American life. It was an early and fruitful chapter in what we are at last finding the assurance to recognize as our own architectural tradition.

This architecture is above all the expression of the new way of life in America. It shows the desire to feel one's self as an individual, the desire for freedom, both from conventions and from drudgery. It pays homage to the out-of-doors. It shows the attitude of its owners toward health, comfort and his fellowman.

It is this which gives it its form, rather than a concern with abstract art, or an attempt to copy the forms of the machine age. This is the unifying force one feels behind the work of the whole period, differing though the capacities and the opportunities of the various architects are seen to be. When one looks at this work he feels that the water has all come from one well, that every man has dipped out of the same bucket.

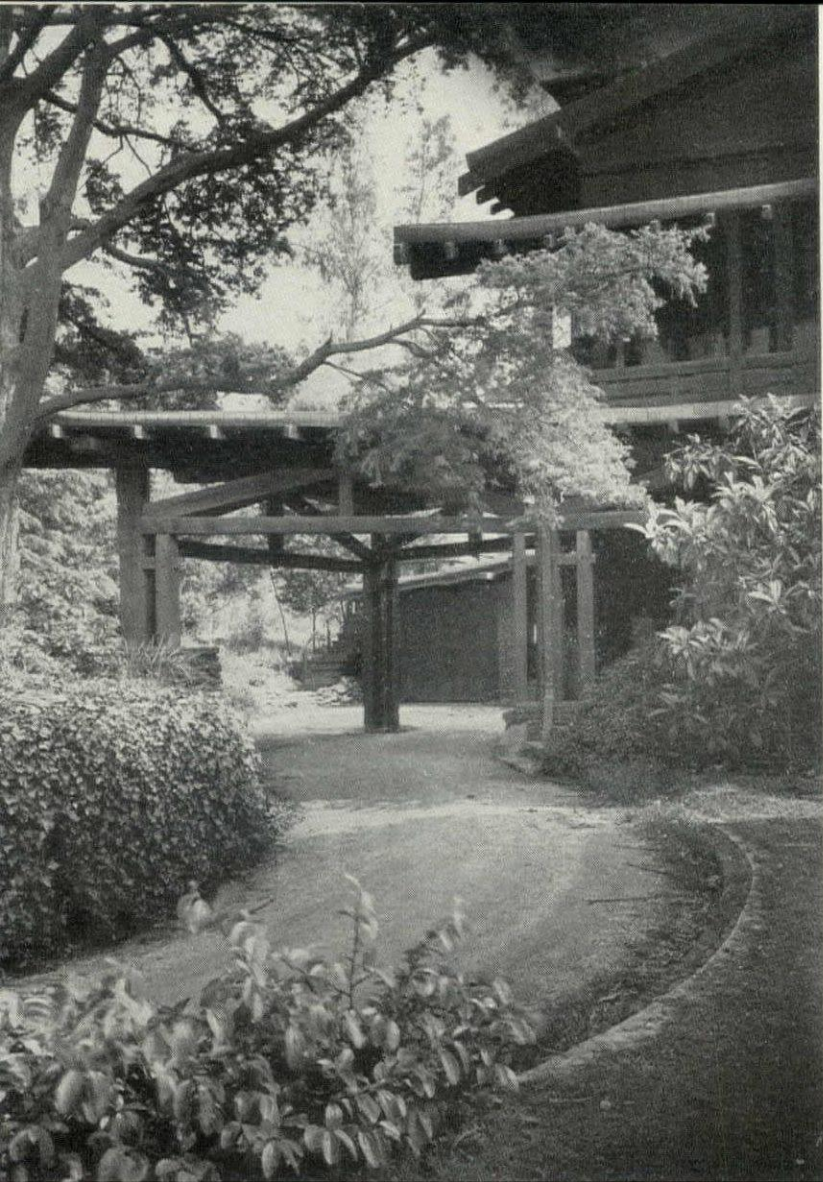

Wood house in Pasadena shows exposed rafters and clean post-and-lintel construction, both reminiscent of the pagoda. The art of making structure part of landscape, in which the Greenes showed great ability, is, of course, one in which the Chinese have never been excelled.

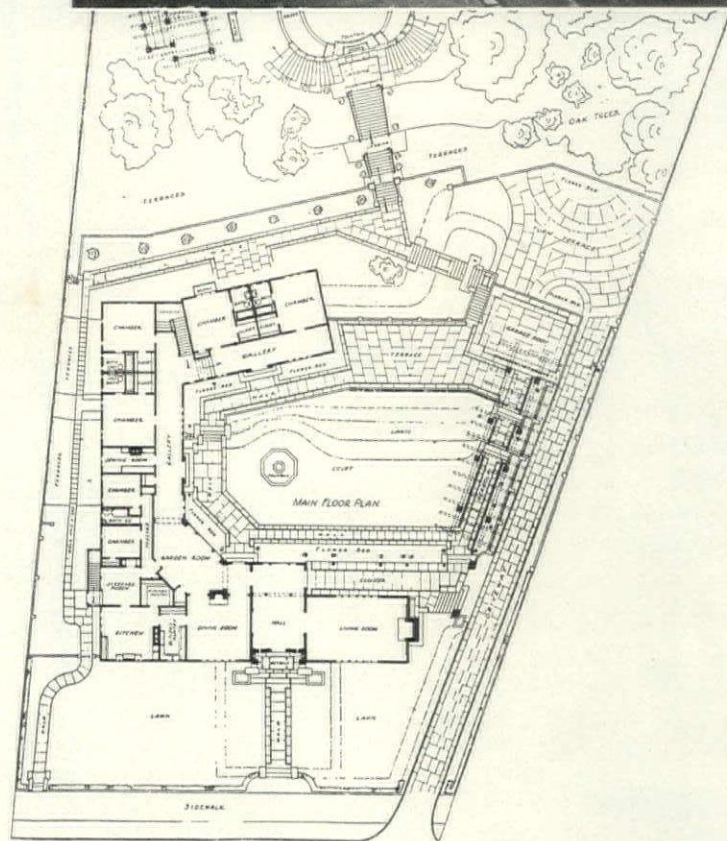
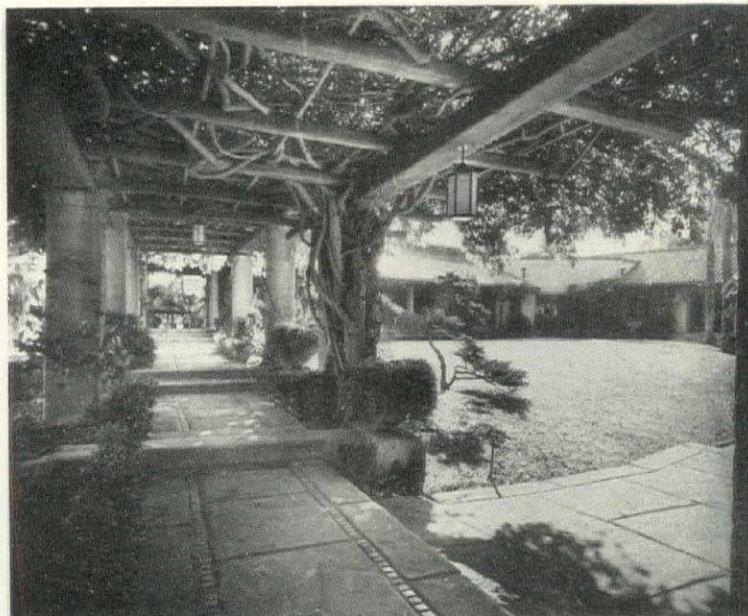

House built for Culbertson sisters (1911) was later purchased by Mrs. F. F. Prentiss, who came from a Cleveland Standard Oil family. A large and expensive house, it shows an extremely modest side to the street. The simple, low-set facade is a direct antecedent of the California Bungalow which became a widespread American building type. Plan shows how Greene brothers refined basic patio plan, one wing here being carried out by beautifully trellised pergola.

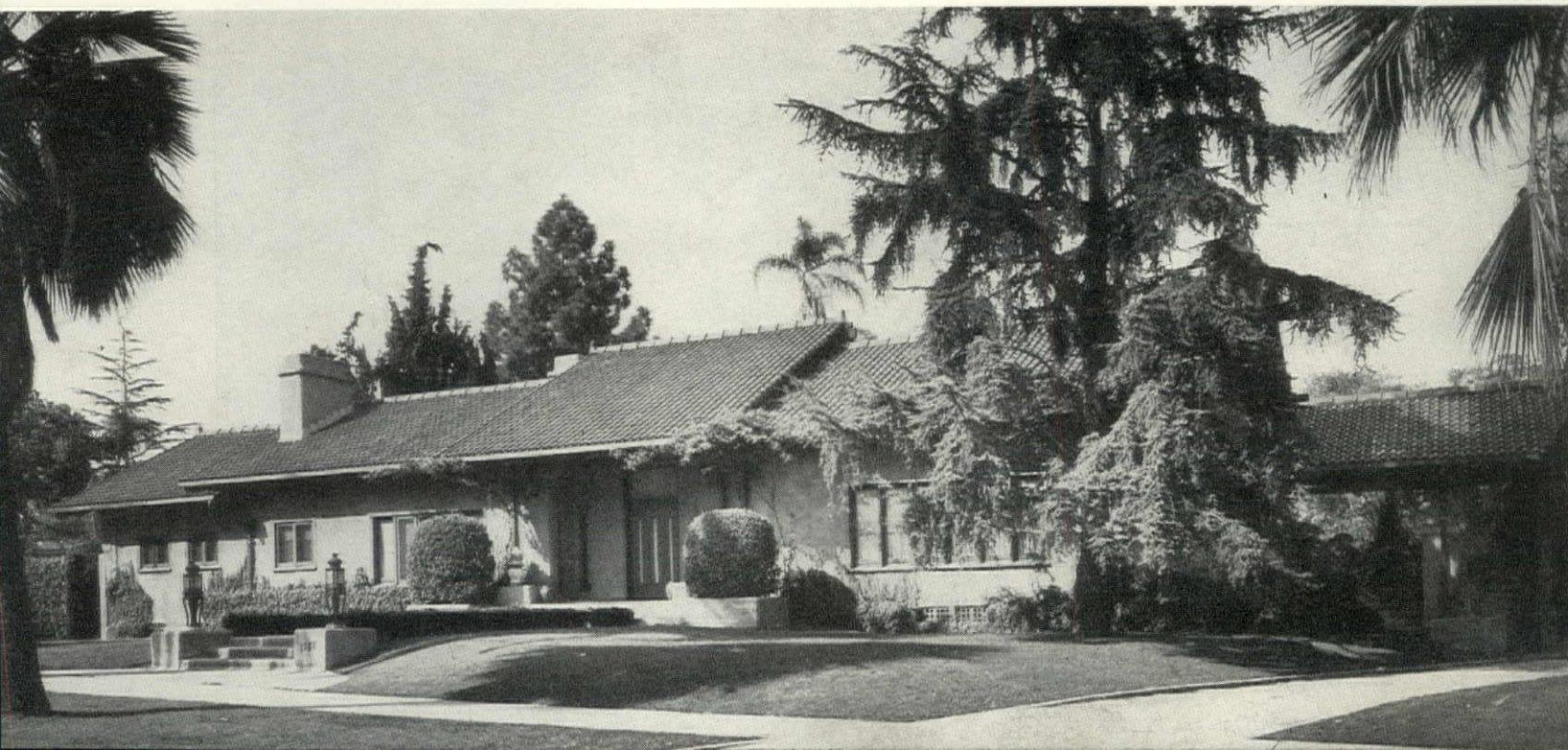

MAINTENANCE BASE United Air Lines stream

MULTI-DECKED MAINTENANCE PLATFORMS PROVIDE NEW, EFFICIENT STANDARD FOR OVERHAULING LARGE PLANES

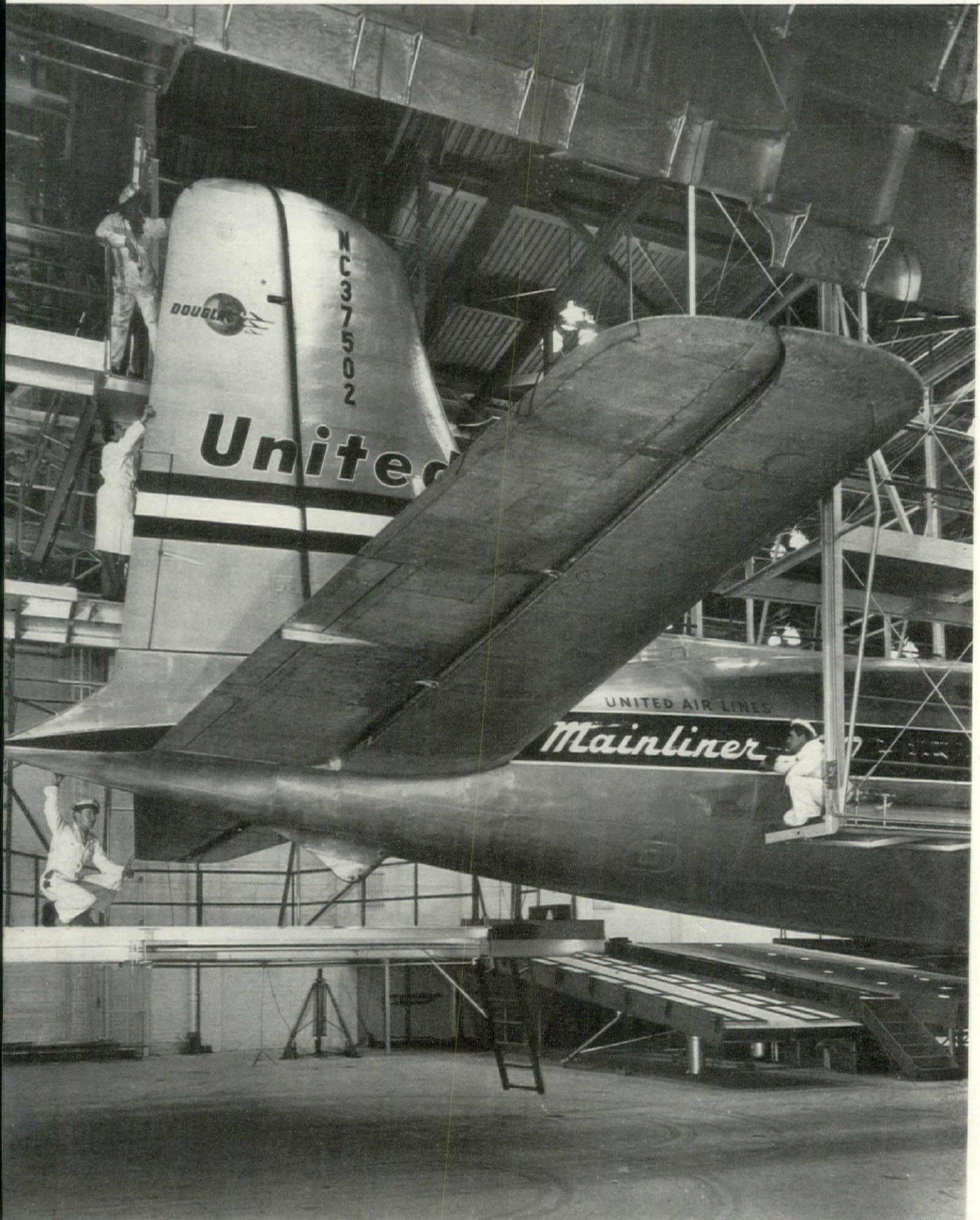

The Austin Co.

maintenance operation at San Francisco installation in move to save time, dollars

THE AUSTIN CO., Engineers and Builders

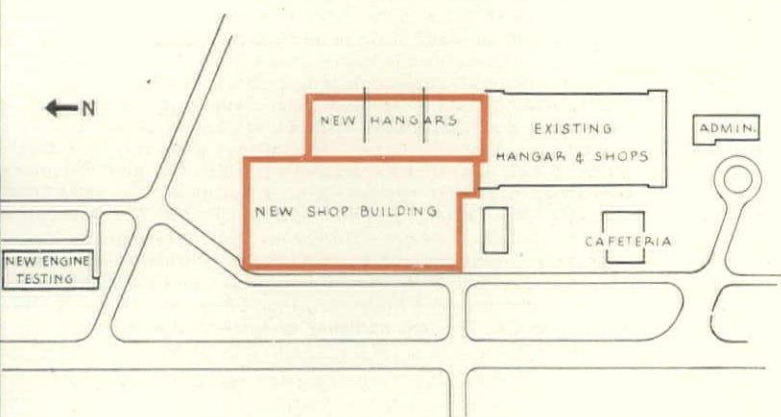

United Air Line's new central maintenance base at Mills Field, Calif., represents the first major attempt by a commercial airline to cut costs, up efficiency by overhauling its planes on an assembly line basis. Like other airlines, United has been faced with zooming operational costs since the end of the war. Stiff competition from other lines has made it reluctant, however, to raise fares further or to curtail services. Profitable operations, therefore, are contingent upon doing a better job of moving payloads through every possible revenue mile. The Mills Field base is the kingpin of the United's operational efficiency program. Time spent in overhauling its planes at the new base has been cut from five to four days, a record made more significant by the fact that each day a DC-6 is grounded for maintenance, the airline loses \$4,000 in revenue. The Mills Field installation cost \$4.5 million, an investment United hopes will soon be written off in operational savings.

SIZE OF NEW SHOP AND HANGARS EMPHASIZES SCOPE OF EXPANDED MAINTENANCE OPERATION AT MILLS FIELD BASE

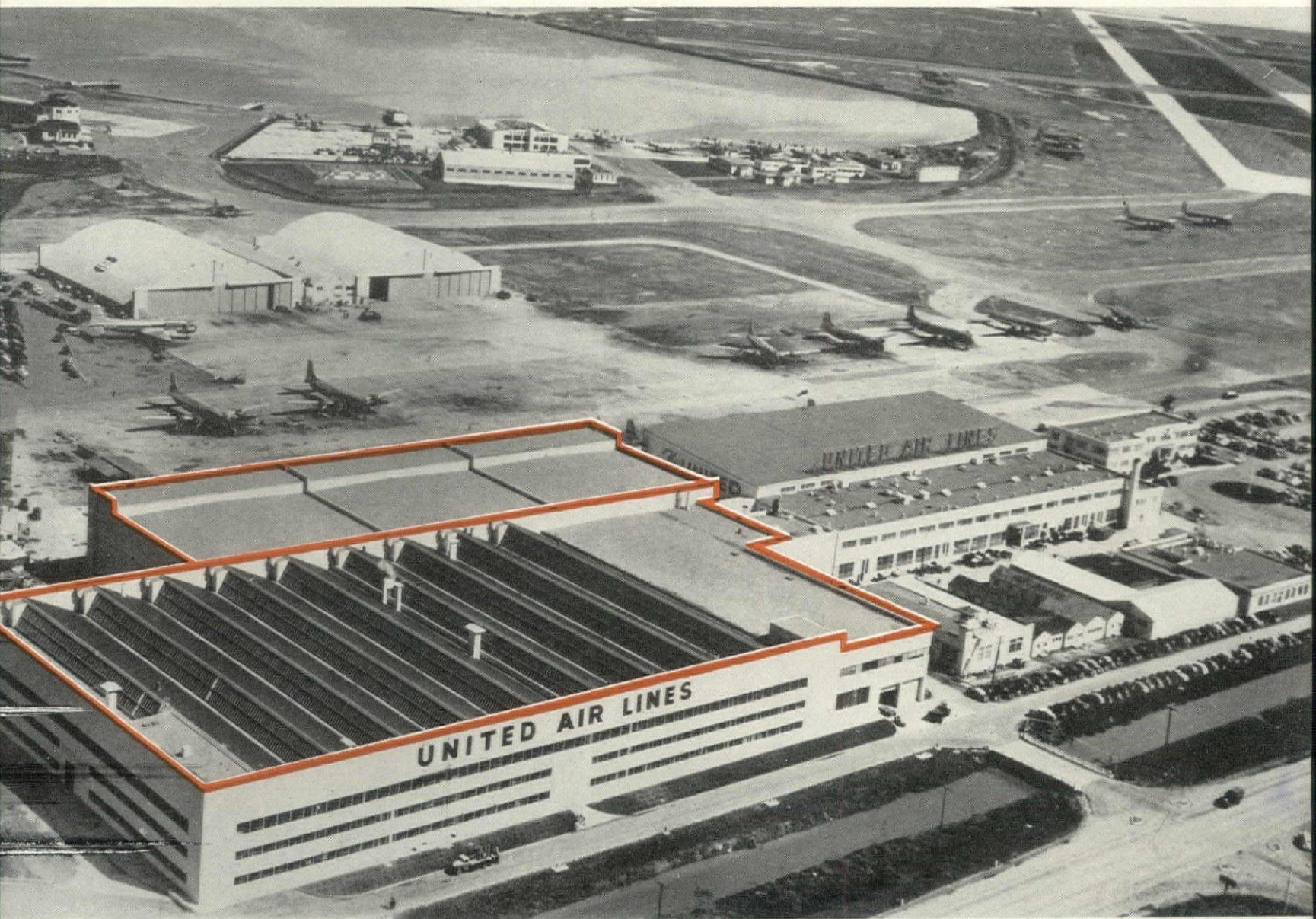

New maintenance shops and adjoining hangars provide assembly-line facilities for overhauling planes

By year's end, United's shops at Mills Field will service all of the airline's 147 Mainliners and Cargoliners, as well as planes on contract from other airlines. Equipped to handle eleven planes at a time, the base has adapted many aircraft-factory techniques to its function of producing "new" planes on a close-scheduled timetable.

Most of the overhaul facilities are under one roof—a two-story-and-mezzanine maintenance building with three adjoining hangars. Planes are wheeled into the hangars, then stripped of all equipment from engines to ashtrays. The disassembled parts are then moved by chain conveyor, elevators and dollies to areas throughout the maintenance building. Self-contained shops are equipped to process or replace engines, propellers, radio equipment, instruments and cabin upholstery. Typical of the installations in the 325,000 sq. ft. building is a decompression chamber which checks instruments under simulated altitudes up to 50,000 ft. A separate engine-testing building is equipped to handle six engines at a time. Interior layout of the shops is flexible, with movable wire-mesh partitions separating most areas. A special color scheme of blue, gray and green shades is varied from room to room to alleviate monotony, provide maximum light reflection with a minimum of glare. Lighting throughout is continuous fluorescent strips.

CONSTRUCTION OUTLINE: Foundations—concrete, Raymond Concrete Pile Co. **STRUCTURE (Shop Building):** Exterior walls—concrete block walls with Johns-Manville, Inc. corrugated Transite above. (Hangars)—reinforced concrete. Interior partitions—glazed tile in lavatories, Kraftite Co.; office and industrial partitions, The Mills Co. Wire mesh—Bethlehem Steel Co. Structural steel—welded rigid frame sawtooth in part of 2nd floor; beam and columns in balance, The Austin Co. Hangar trusses—Bethlehem Steel Co. Floors—flat slab concrete. **ROOF**—Truscon Steel Co. Ferrobord roof deck covered with Sata Fiber roof deck insulation by Owens-Corning Fiberglas Corp. and Paraffine Co.'s, Inc. built-up tar and gravel roofing. **SHEET METAL WORK**—U. S. Steel Corp. **SOUND INSULATION** (Engineering Corp)—Muffitone acoustical tile, The Celotex Corp. **WINDOWS:** Sash—Truscon Steel Co. projected steel sash. Glass—Libby-Owens-Ford Glass Co. **FINISH FLOORING**—concrete, asphalt tile, Armstrong Cork Co. **CONCRETE FLOOR HARDENER**—Master Builders Co. **WOOD AND METAL TRIM:** Doors (Interior): Kalamein and tin-clad. Garage and special doors—Truscon Steel Co. vertical life canopy hangar and industrial steel doors, and Kinnear Mfg. Co steel rolling doors. **HARDWARE**—Schlage Lock Co. **PAINTS**—W. P. Fuller Co. **ELECTRICAL INSTALLATION:** Switchgear sub-stations and circuit breakers—I.T.E. Circuit Breaker. Panel boards and plug-in circuit breakers bus duct—Westinghouse Electric Corp. Special equipment: Transformers—General Electric Co. Lighting fixtures—The Miller Co. and Holoplane Co., Inc. **PLUMBING:** Sprinkler system—Viking Sprinkler Co. **HEATING AND AIR CONDITIONING:** Heating—steam system. Boiler, The Babcock & Wilcox Co. Air conditioning: Blowers—Sturtevant Div., Westinghouse Electric Corp. Unit heaters—Trane Co. and L. J. Wing Co. Diffusers—Anemostat Corp. of America, Mercoird Corp. and Johnson Service Co. and Barber Coleman Co. Electric Airmat—American Air Filter Co., Inc. **SPECIAL EQUIPMENT:** Alarm system—Autocall Co. Fire extinguisher system—Walter Kidde.

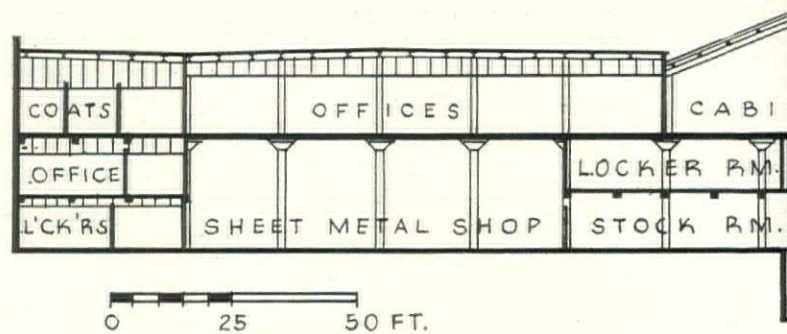

HORIZONTAL BANDS OF PROJECTED STEEL SASH EMPHASIZE LENGTH (485 FT.) OF MAINTENANCE SHOP





GLARE-REDUCING GLASS IN SAWTOOTH ROOF IMPROVES SECOND-FLOOR LIGHTING
CALIBRATION AND TESTING OF INSTRUMENTS IS CARRIED OUT IN SPECIAL BOOTHS

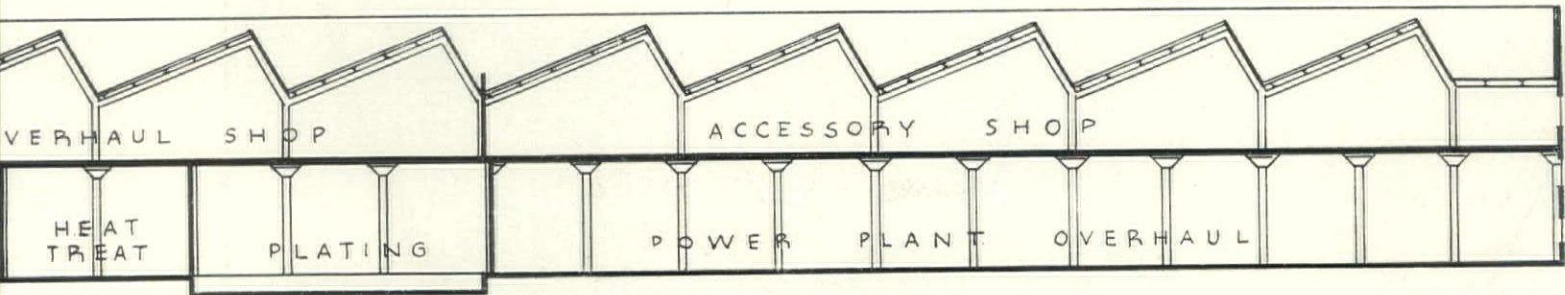
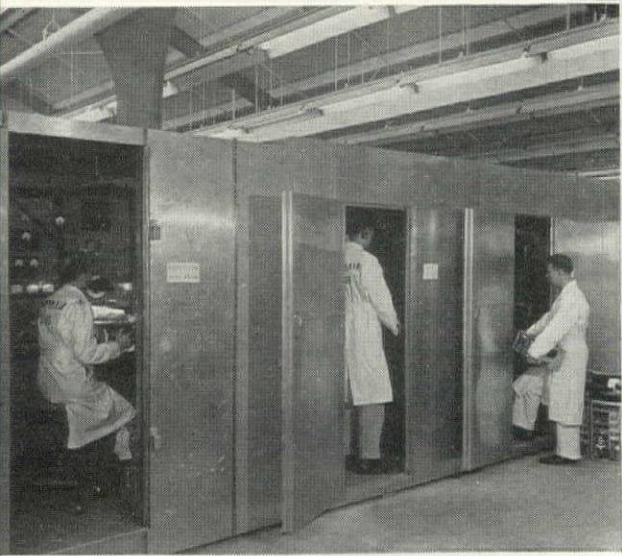

LONGITUDINAL SECTION LOOKING WEST

FIRST FLOOR OF MAINTENANCE SHOP IS DEVOTED LARGELY TO ENGINE OVERHAUL
CONTINUOUS CHAIN CONVEYORS PROVIDE QUICK MOVEMENT OF EQUIPMENT, PARTS



Overhauling operation speeded by unique "push-button" platform apparatus suspended from ceiling

Moving a plane into position for overhauling in a hangar normally takes over an hour, ties up 40 to 50 men. This time is cut down to ten minutes at Mills Field, mainly through the use of the elaborate cat-walk apparatus (see photo-diagram below) installed in one of the hangars.

Unlike the old system of cumbersome portable platforms, mechanics are able to move with ease to any part of the craft along multi-decked walks which flank the plane from nose to tail. The frameworks are light-structural steel with plywood platforms. A three-ton electric crane, suspended from the ceiling, services all parts of the plane. The hangar is lit by ceiling clusters of mercury-vapor and incandescent lamps and by additional platform lights.

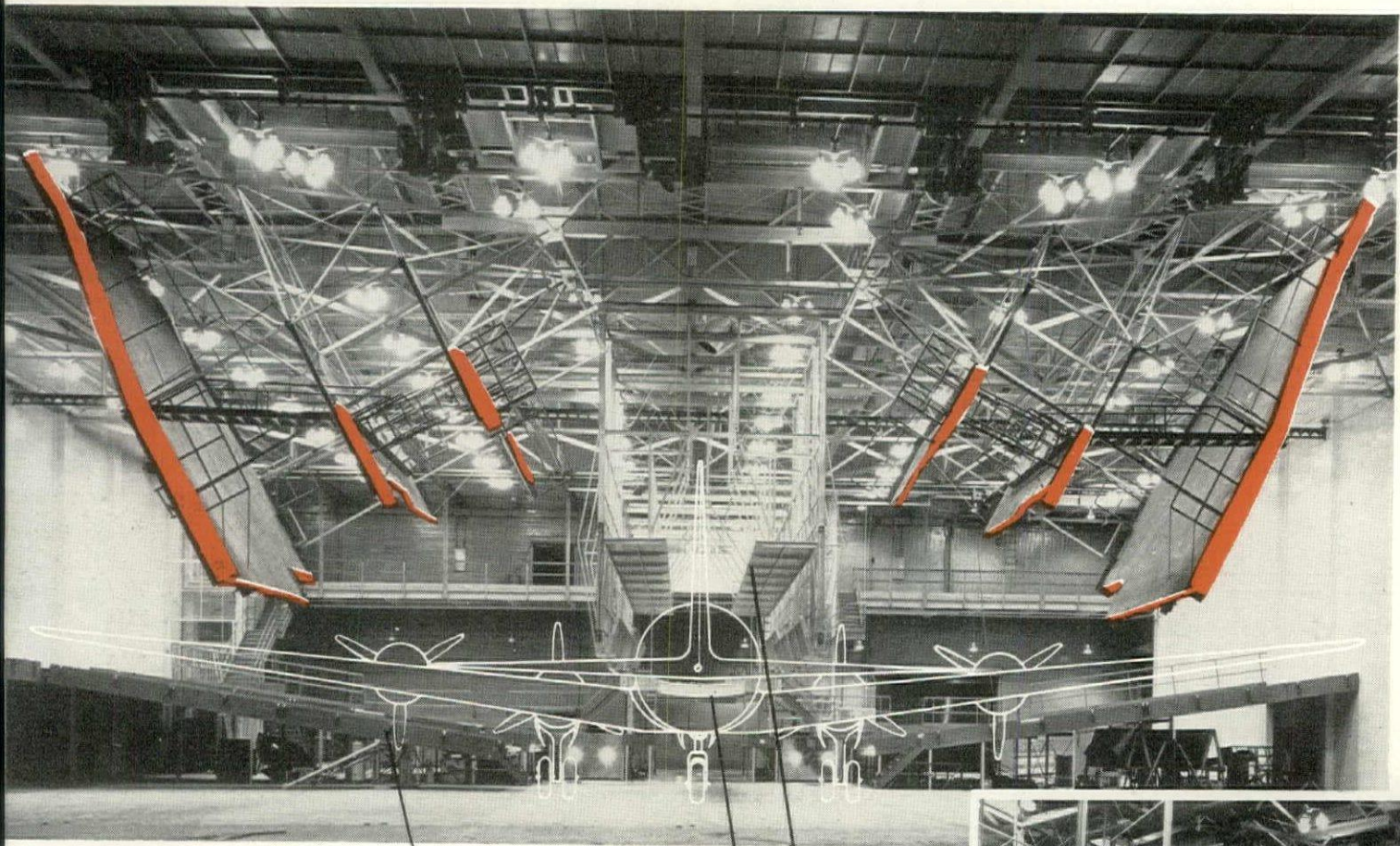

HYDRAULICALLY OPERATED RAMPS, LEADING TO ELEVATORS, FACILITATE REMOVAL OF HEAVY PARTS

PLANE'S NOSE FITS AGAINST FORWARD PLATFORM WHERE ELEVATORS OPERATE TO SECOND FLOOR MAINTENANCE SHOPS

RETRACTABLE CATWALKS WITHIN SUSPENDED FRAMEWORK SERVICE FUSILAGE

TWO 1-TON, TRIPLE-DECK FRAMEWORK UNITS, OPERATED BY 1/2 H.P. MOTORS, DESCEND FROM CEILING TO SERVICE TAIL ASSEMBLY

25-TON STEEL DOOR, OPERATED BY 6 H.P. MOTOR, OPENS IN 15 SECONDS

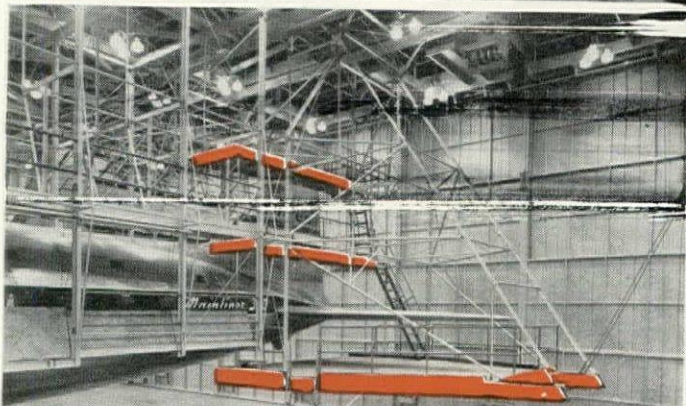
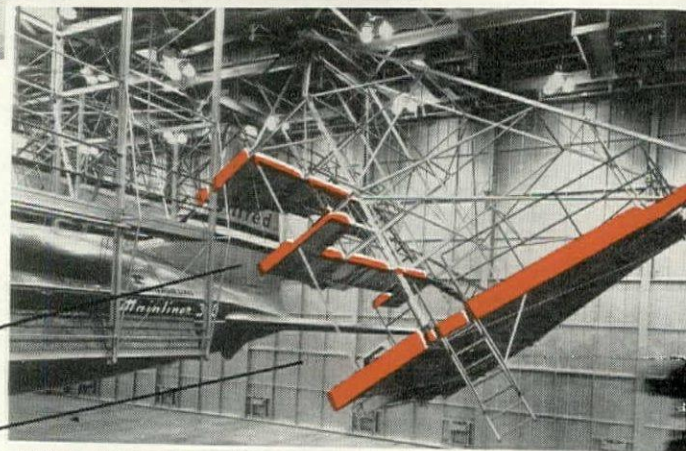

SMALL THEATER provides high technical standards for rural moviegoers

LOCATION: Clara City, Minn.
 GEORGE BECKER, Architect
 SEBCO INC., Designer and Builder
 A. F. R. SVENSSON, Interior Designer

This 490-seat theater is a prototype for a dozen movie houses being put up in midwestern communities by Sebco Inc., a Minneapolis design and building firm specializing in theater construction. Sebco's stock plan was developed with an alert eye on a) the technical requirements for a modern theater, b) the all-important cost factor. Giving short shrift to "movie palace" pretensions, the plan concentrated instead on a suitable solution to the visual and acoustical problems of presenting motion pictures in a small auditorium. Sight and sound requirements were developed for a standard-size hall and screen, then applied to all theaters built under the stock plan.



SIMPLE CANOPY IS DISTINGUISHING FEATURE OF FACADE

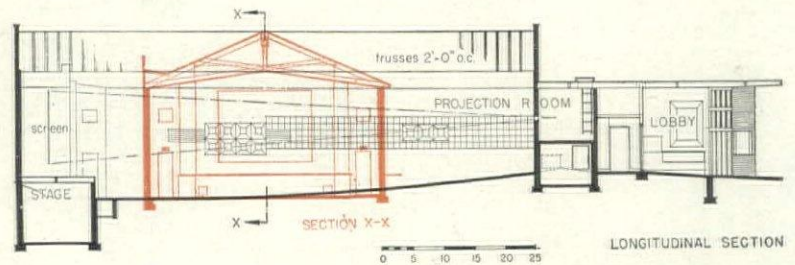
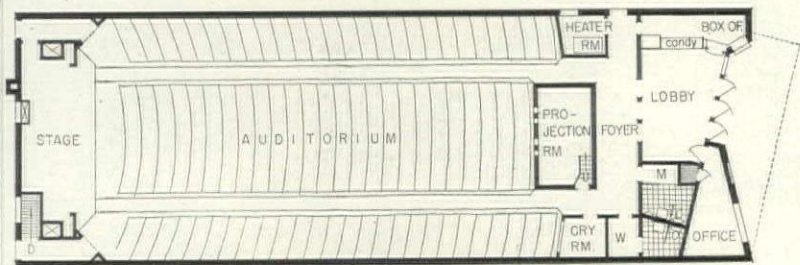

The theaters are built almost entirely by conventional methods. Economies are effected by close cost-engineering and elimination of non-essentials. The orthodox—and costly—second-floor layout for the projection room was abandoned in favor of a booth raised 4 ft. above the rear of the main auditorium. The auditorium roof structure consists of trussed rafters, spanning 24 ft. The top chords carry the sheathing and roofing and an insulation-board ceiling is nailed directly to the bottom chords. By careful scheduling of materials and equipment on the site, the Star theater, shown here, was built in ten weeks. Further economies in Sebco's small-theater operation in the future will be effected by shop fabrication of such items as the box office, candy counter and projection booth wiring system.

These savings are imperative under present-day building costs, which threaten the economic soundness of such ventures. The Star theater was built last winter by Sebco for \$38,000 on a firm bid. Adding to the building cost about \$12,000 worth of theater equipment, the cost-per-seat for the complete theater is around \$100. This is in striking comparison to the \$175-\$250 per seat cost for other theaters built in the same area at the same time.

CONSTRUCTION OUTLINE: Foundation—concrete; Waterproofing—R.I.W. Toch Bros., Inc. STRUCTURE: Exterior walls—12 in. concrete block. Interior partitions—2 x 4 wood stud. Floors—concrete or concrete slab. ROOF—wood rafters, sheathing and 3-ply composition. INSULATION: Roofs—4 in. rock-wool. SOUND INSULATION—Acousti-Celotex, Celotex Corp. WINDOWS: Sash—wood casement. Glass—double strength, quality AA. FINISH FLOORINGS: Lobby and cry-room—asphalt tile. Foyer, office and auditorium—carpet. WALL COVERINGS: Auditorium—cement, plaster wainscot. Lobby and foyer—plywood. Remainder—plaster. ELECTRICAL INSTALLATION: Wiring system—3-wire steel conduit. PLUMBING: Soil pipe—cast iron. Remainder—galvanized iron. HEATING AND AIR CONDITIONING: Heating—forced hot air system. Cooling by city water and single stage. Washer and grilles—U. S. Air Conditioning Corp. Thermostats—Minneapolis Honeywell Regulator Co.

George Miles Ryan Studio



Gaily-decorated "cry-room" is sound-proof solution for the noisy-infant problem



Large candy counter stresses theater's reliance on sale of sweets for extra revenue

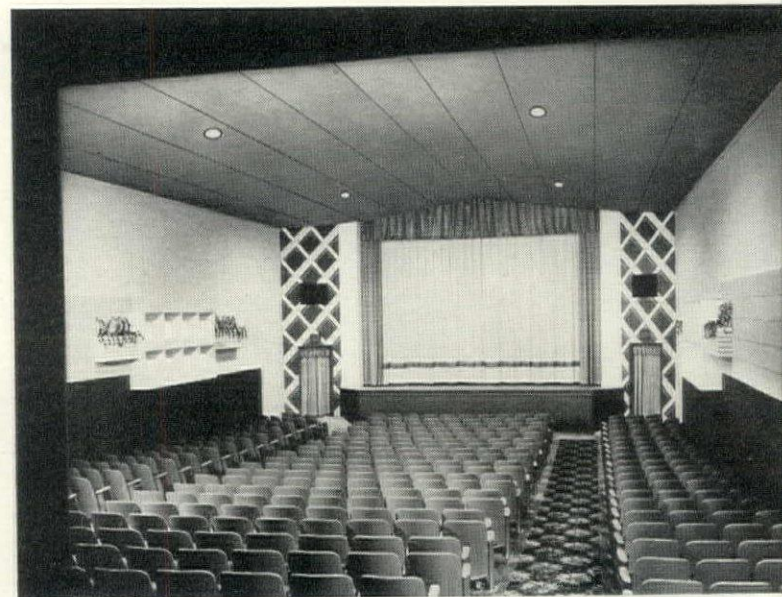



BIRD'S-EYE VIEW SHOWS THREE CLEARLY DEFINED UNITS: GARAGE AND SERVANTS' ROOMS (LEFT) BEDROOMS (CENTER) LIVING (RIGHT)

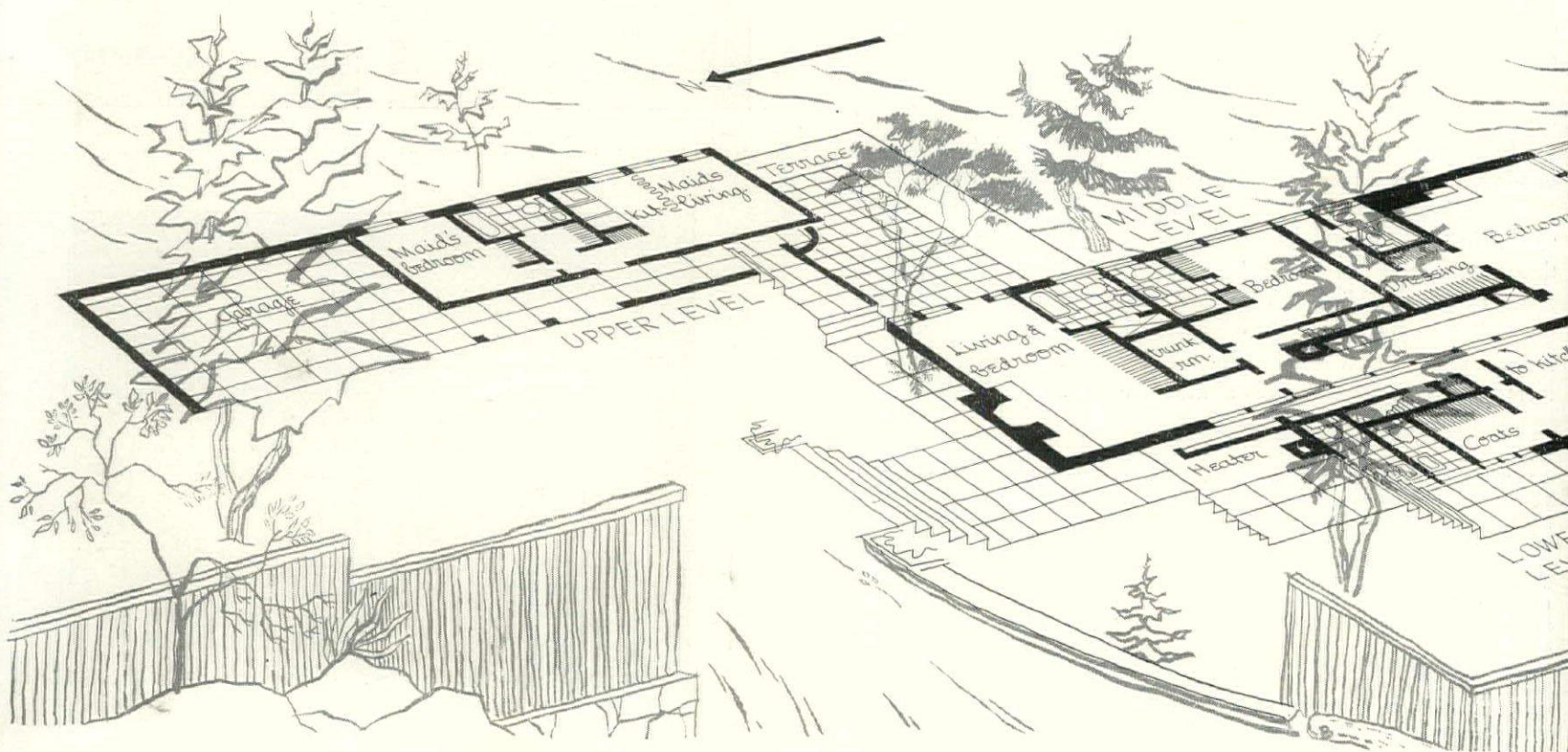

Cliff house whose interlocked elements exploit a magnificent site is Canadian contribution to organic architecture

W. S. BROOKS HOUSE, Vancouver, B.C.

SHARP & THOMPSON, BERWICK, PRATT, Architects

F. W. ORRY

P. WISNICKI and MRS. P. WISNICKI } Consulting Engineers

A. E. SIMPSON }

MAXWELL CONSTRUCTION CO. LTD., Contractors

For a dramatic, pine-clad cliff property overlooking the Gulf of Georgia and commanding a panoramic view of greater Vancouver, the architects have designed a luxurious multi-level residence which fits together on its difficult site as neatly as a Chinese puzzle. Placed almost literally on the face of a cliff, the house hugs a drop of 300 ft. from the northwest corner of the property to the sea. The entire site consists of uneven rock outcroppings except for a small plateau beneath the living-dining area. The solution to such a site problem was to break the elements of the house into separate packages (living, sleeping, utility and servants' quarters), then correlate them according to the dictates of the land. Thus the living-dining rooms with adjoining terrace are on the lowest level, facing south toward the best view and partially tucked under the sleeping quarters at right angles. Garage and servants' rooms, completely separated from the main house, are opposite at the highest level, connecting with the kitchen and laundry rooms by a stair and covered outdoor walkway. Wide roof overhangs make it possible to walk completely around the house protected from weather.

SIDE VIEW OF STAGGERED LEVELS: LIVING, SLEEPING, SERVANTS' ROOMS

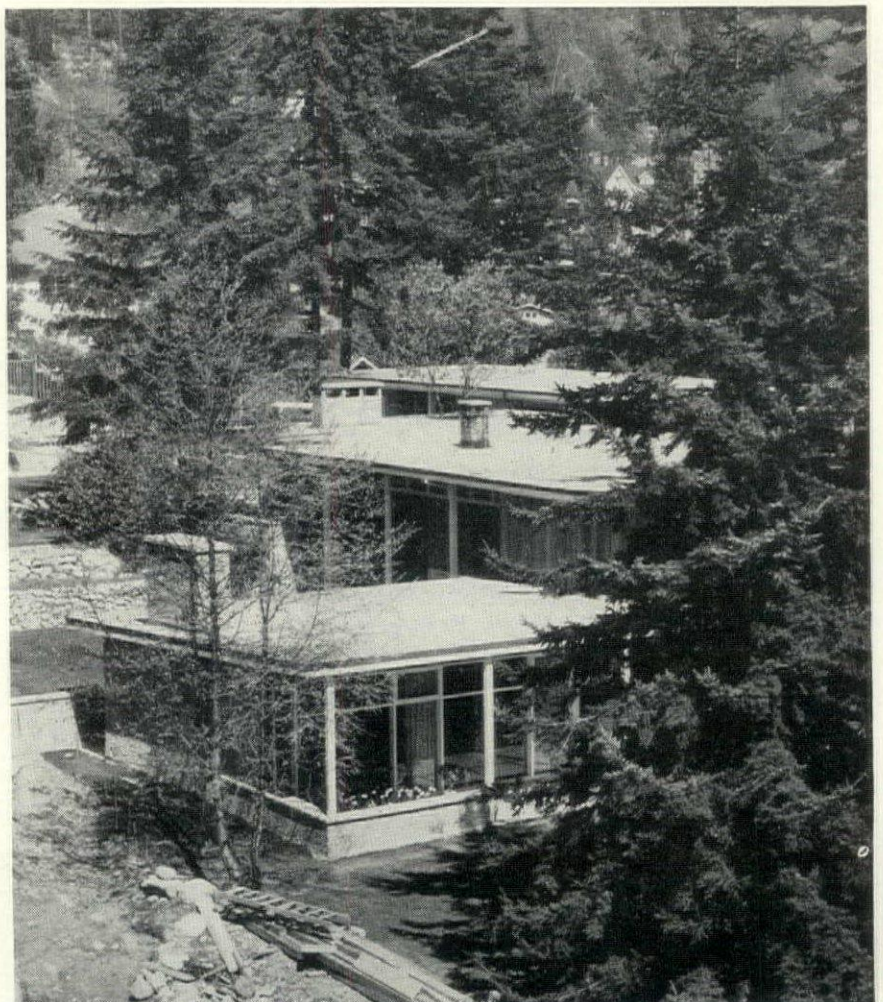
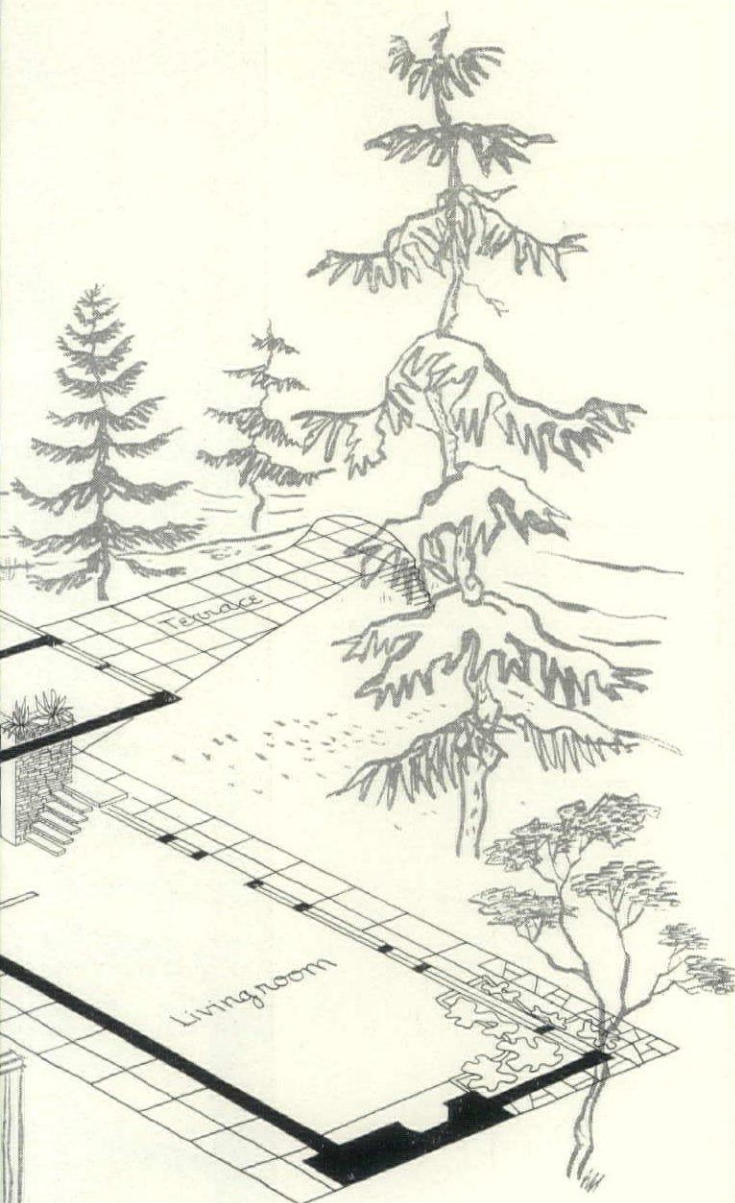

Tony Archer



LOWER FLIGHT OF STAIRS IS CANTILEVERED FROM A CENTRAL BLOCK OF MASONRY

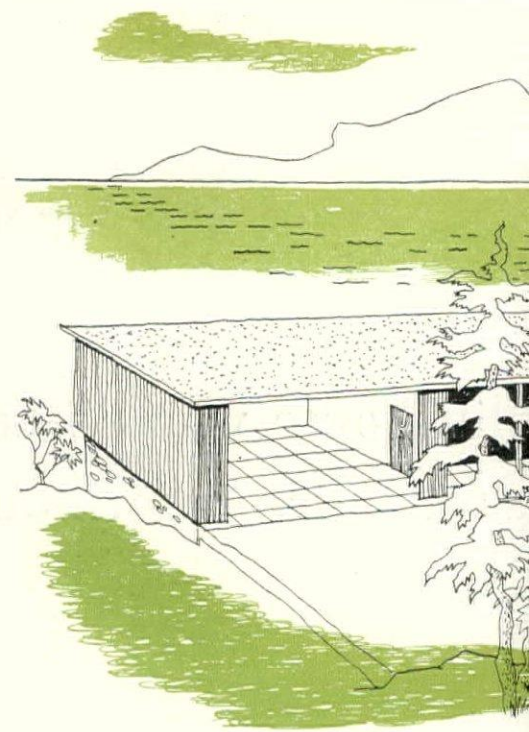

VIEW FROM DINING

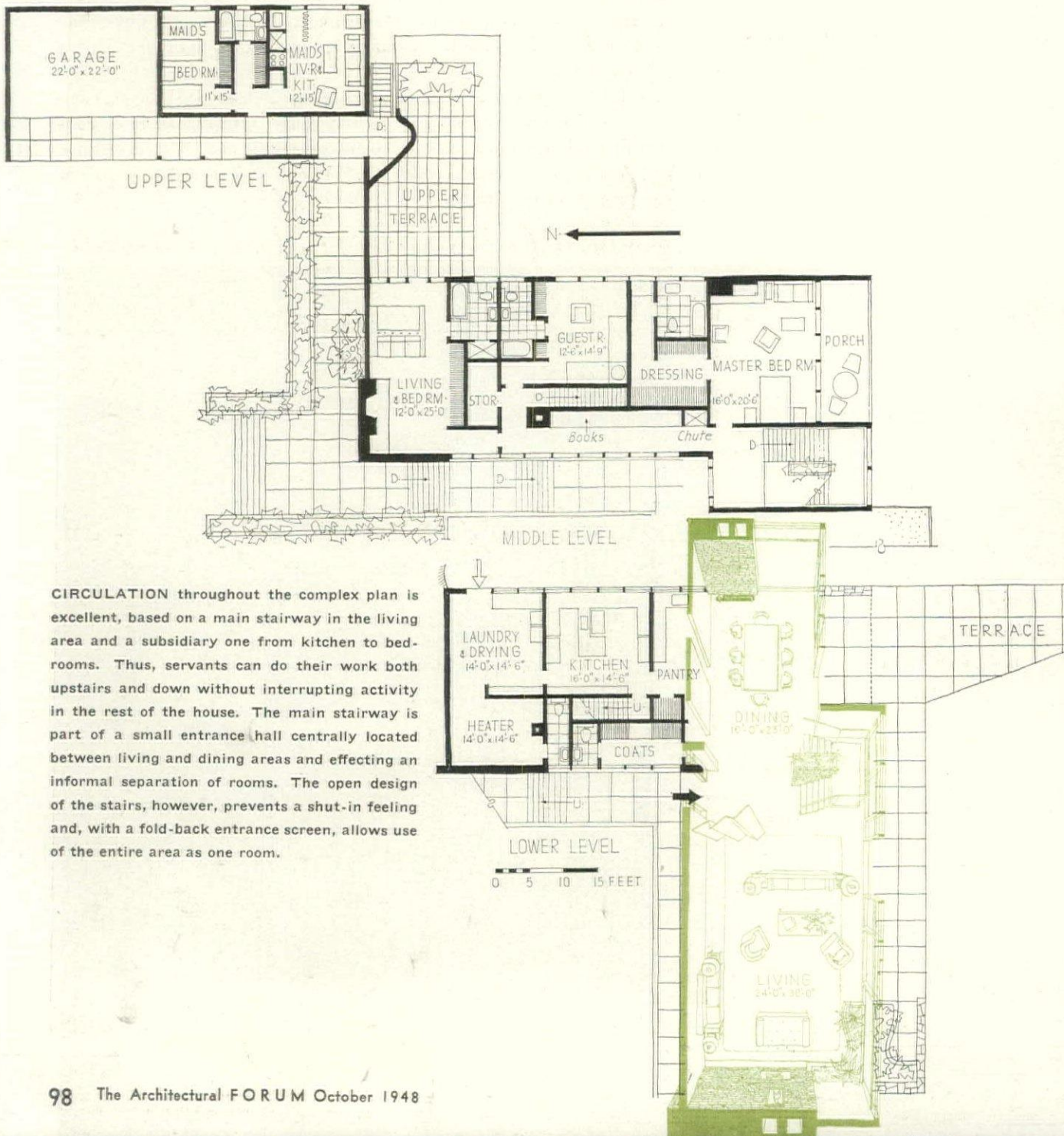

CIRCULATION throughout the complex plan is excellent, based on a main stairway in the living area and a subsidiary one from kitchen to bedrooms. Thus, servants can do their work both upstairs and down without interrupting activity in the rest of the house. The main stairway is part of a small entrance hall centrally located between living and dining areas and effecting an informal separation of rooms. The open design of the stairs, however, prevents a shut-in feeling and, with a fold-back entrance screen, allows use of the entire area as one room.

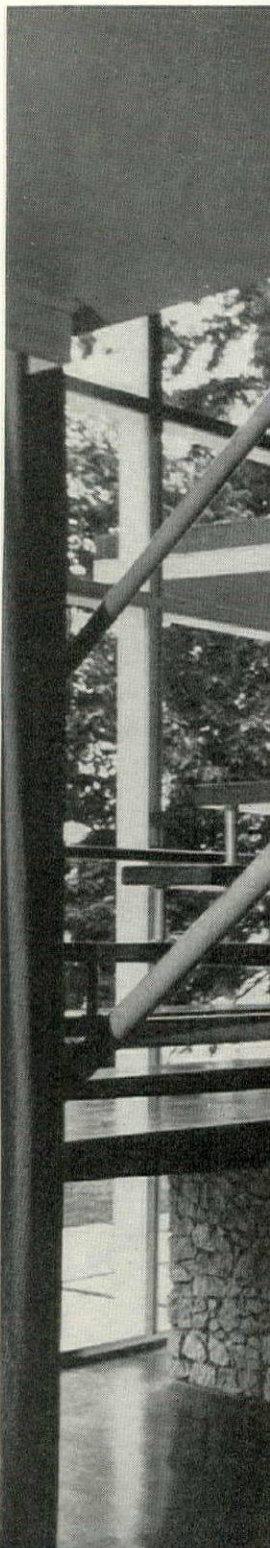

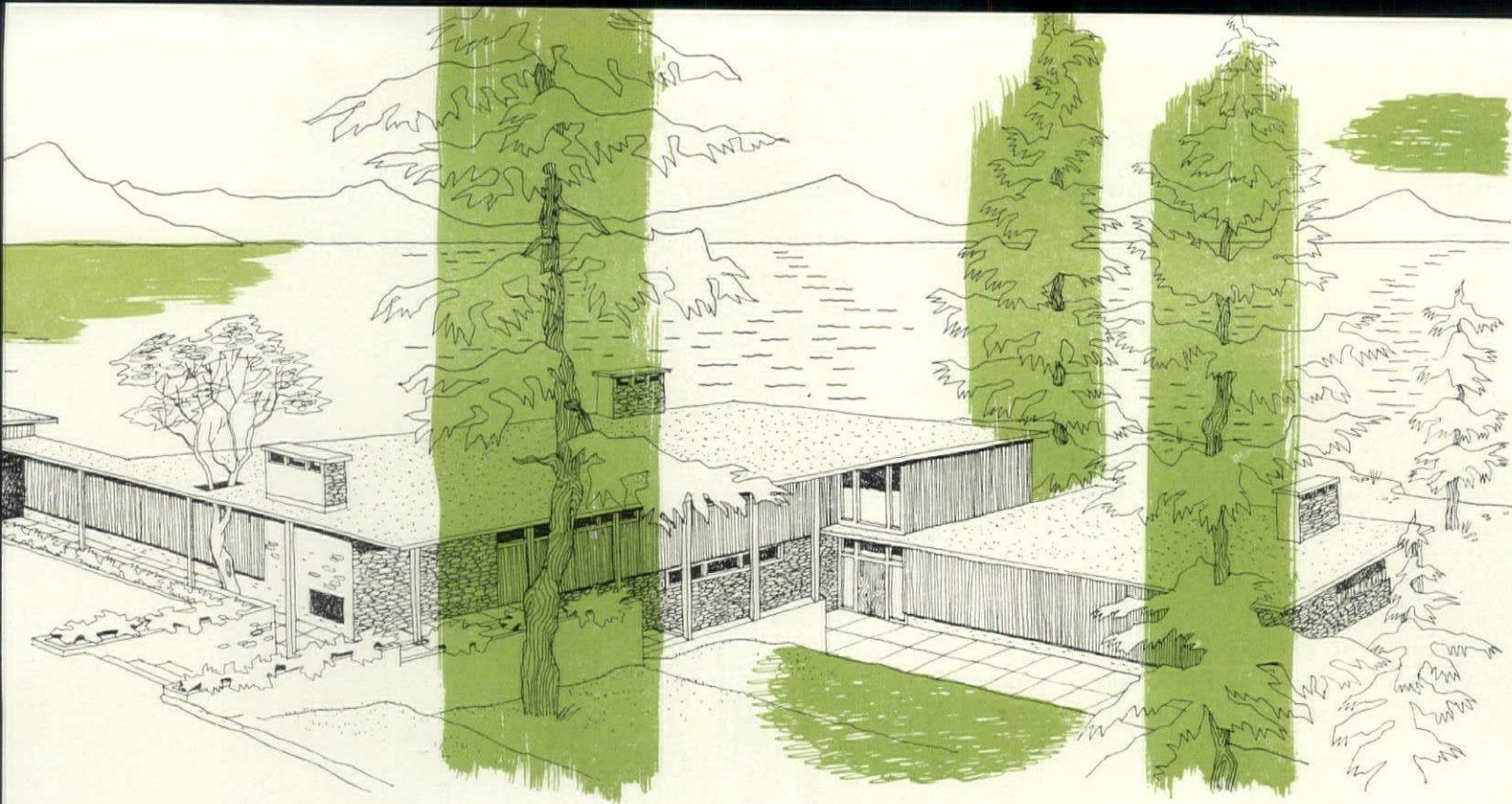

ING ROOM WITH SCREEN FOLDED BACK. UPPER STAIRS WHICH COULD NOT BE CANTILEVERED, MAKE USE OF SLENDER PIPE SUPPORTS



Precise detailing of wood and masonry is attractive contrast to rugged pines

The exterior finish of the house is primarily natural cedar V-joint, varnished, and white painted trim. Masonry walls (both exterior and interior) are made from small granite chips which cover much of the property. They were mixed with mortar and tamped into forms, a simple and economical system already used with great effectiveness in Frank Lloyd Wright's Taliesin West. After setting, mortar which adheres to the finished surface is removed with a wire brush. Radiant heating is used throughout the entire house—floor installations at ground level areas and ceiling installations in the upper stories. Varied finish materials are cemented to the concrete floor slab.

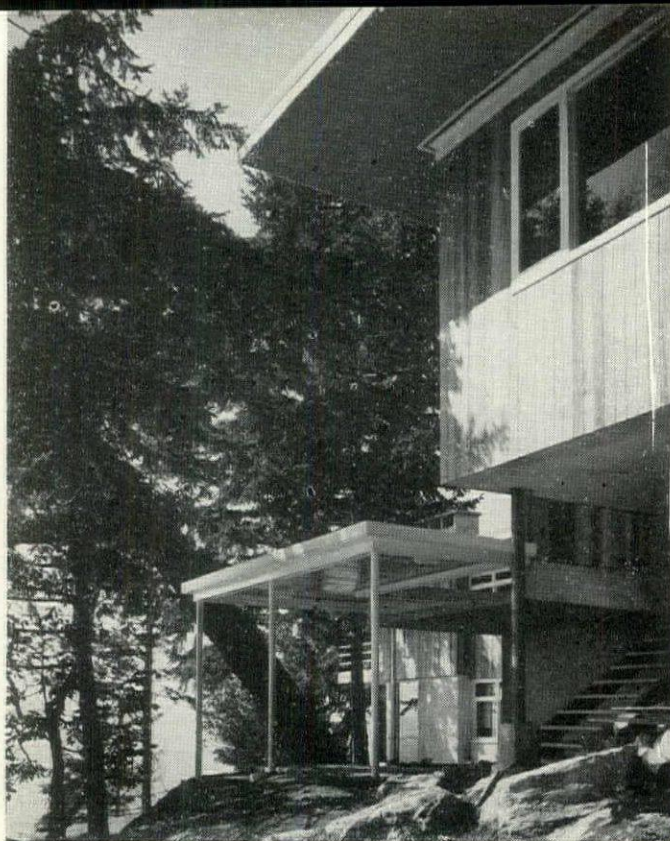

CONSTRUCTION OUTLINE: Foundation—concrete, Portland Cement Co. **STRUCTURE:** Exterior walls—frame, cedar, building paper, diagonal sheathing, studs, plaster board and plaster. Floors—concrete slab. **ROOFING—**20-year bonded, Barrett Div., Allied Chemical & Dye Corp. **INSULATION—**rockwool, Johns-Manville, Inc. **SHEET METAL WORK—**copper. **WINDOWS:** Sash—fir. Glass— $\frac{1}{4}$ in. plate. **FINISH FLOORING:** Living room— $\frac{3}{4}$ in. oak. Kitchen—rubberized tile. Bathrooms—glazed tile. **WALL COVERINGS:** Living room—12 in. clear fir boards. Remainder—plaster. **PAINTS—**Pratt & Lambert, Inc. **HARDWARE—**Schlage Lock Co. **KITCHEN EQUIPMENT:** Range, refrigerator and dishwasher—General Electric Co. **LAUNDRY EQUIPMENT:** Washing machine—Lauderall, F. L. Jacobs Co. **BATHROOM EQUIPMENT—**Kohler Co. **HEATING—**radiant heating system. Burner—Quiet-May Oil Burner Co. Regulator—Minneapolis-Honeywell Regulator Co.

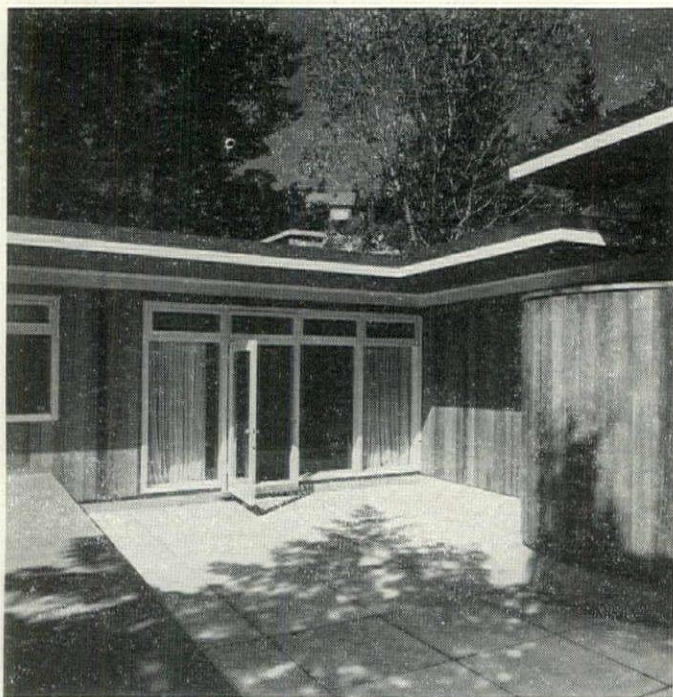

SECOND FLOOR ROOF TERRACE OPENS OFF THE MASTER BEDROOM AND, AT GROUND LEVEL, FORMS A COVERED WALK CONNECTING SERVANTS' QUARTERS WITH MAIN HOUSE

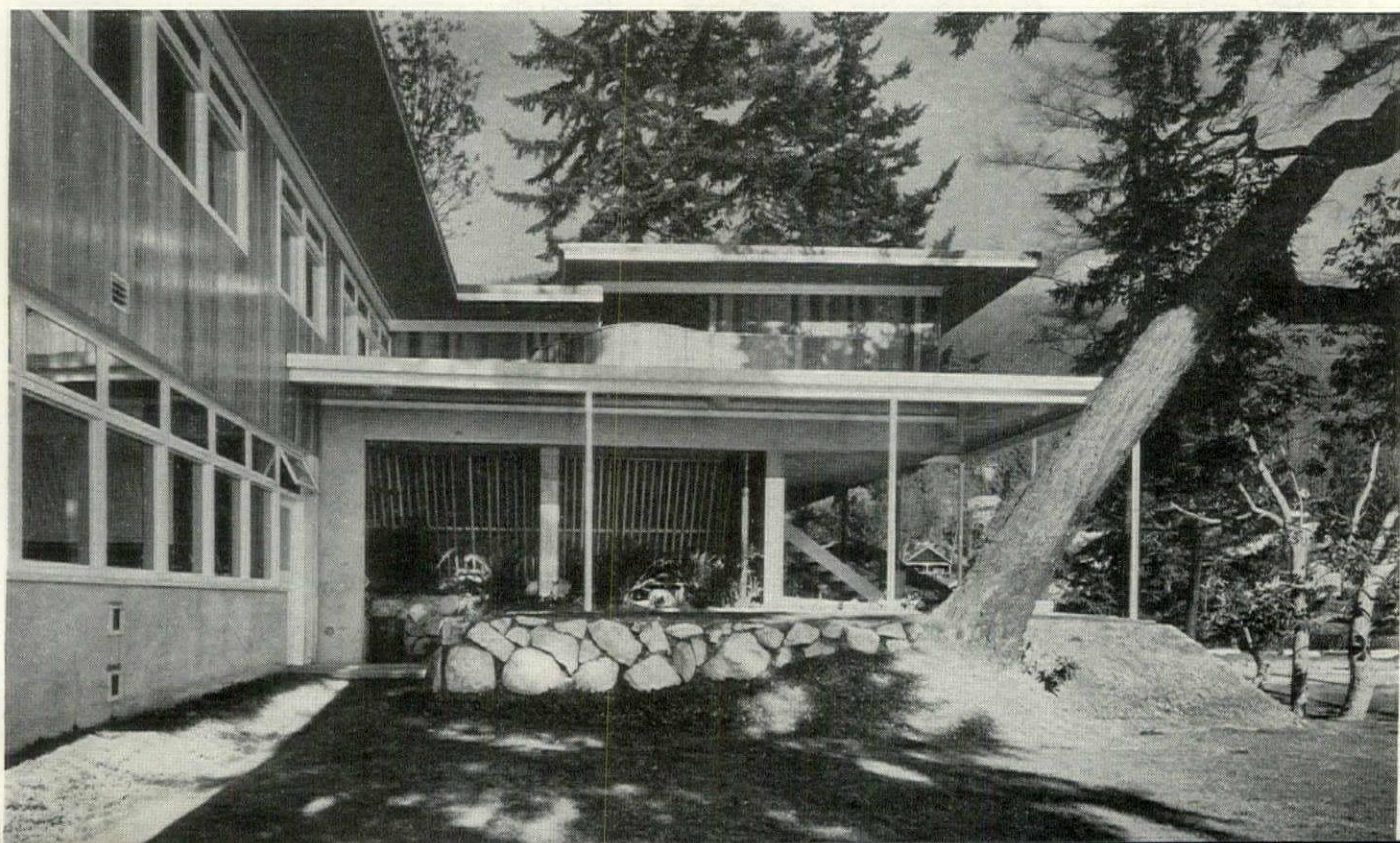

Concrete home in Florida is one of eight prototype houses designed to solve regional building problems

LOCATION: Sarasota, Fla.
RALPH S. TWITCHELL, Architect; PAUL M. RUDOLPH, Associate
SAMUEL NAPP, Consulting Engineer
LAMOLITHIC INDUSTRIES, Builders

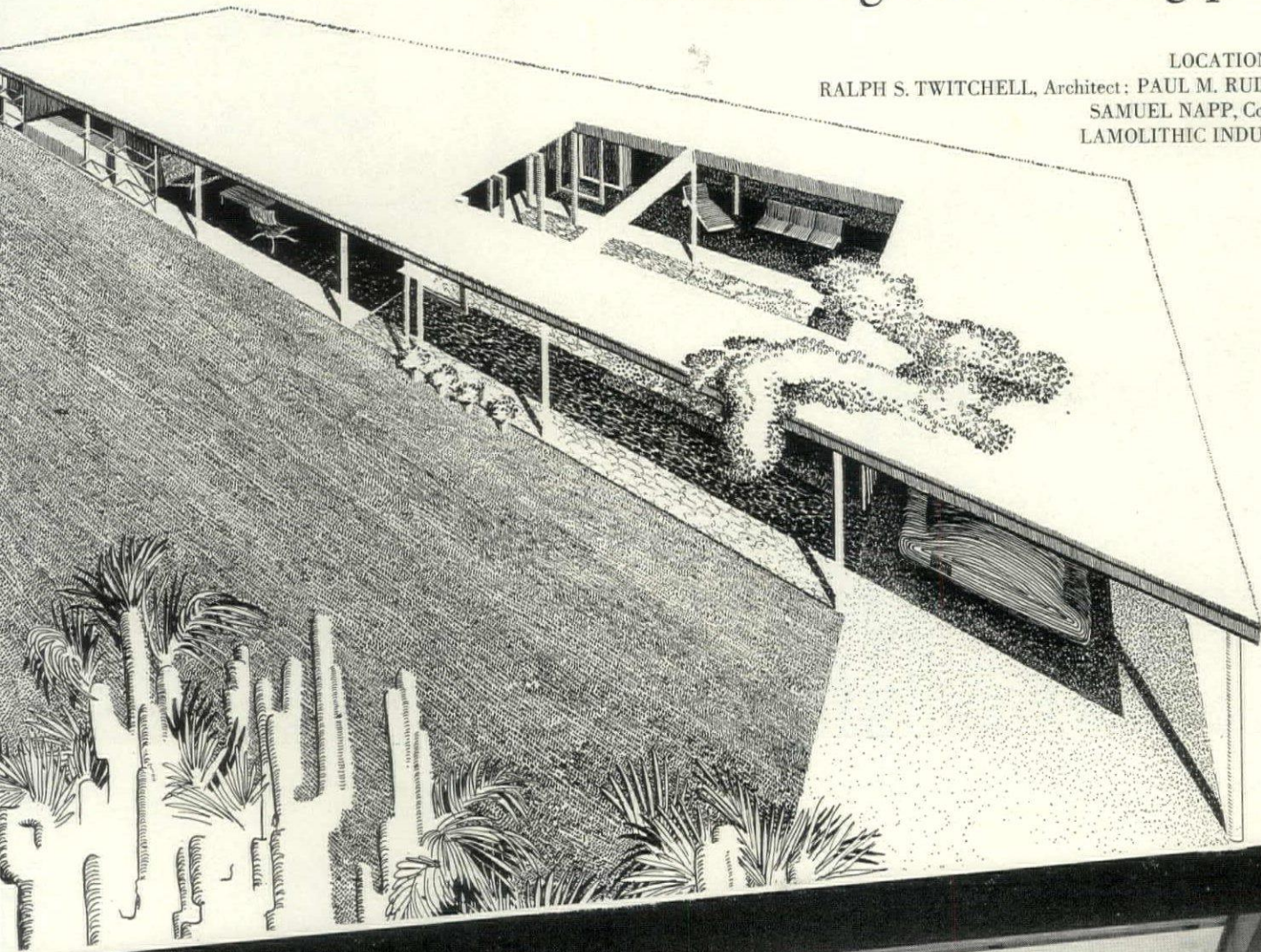

Rodney McCay Morgan



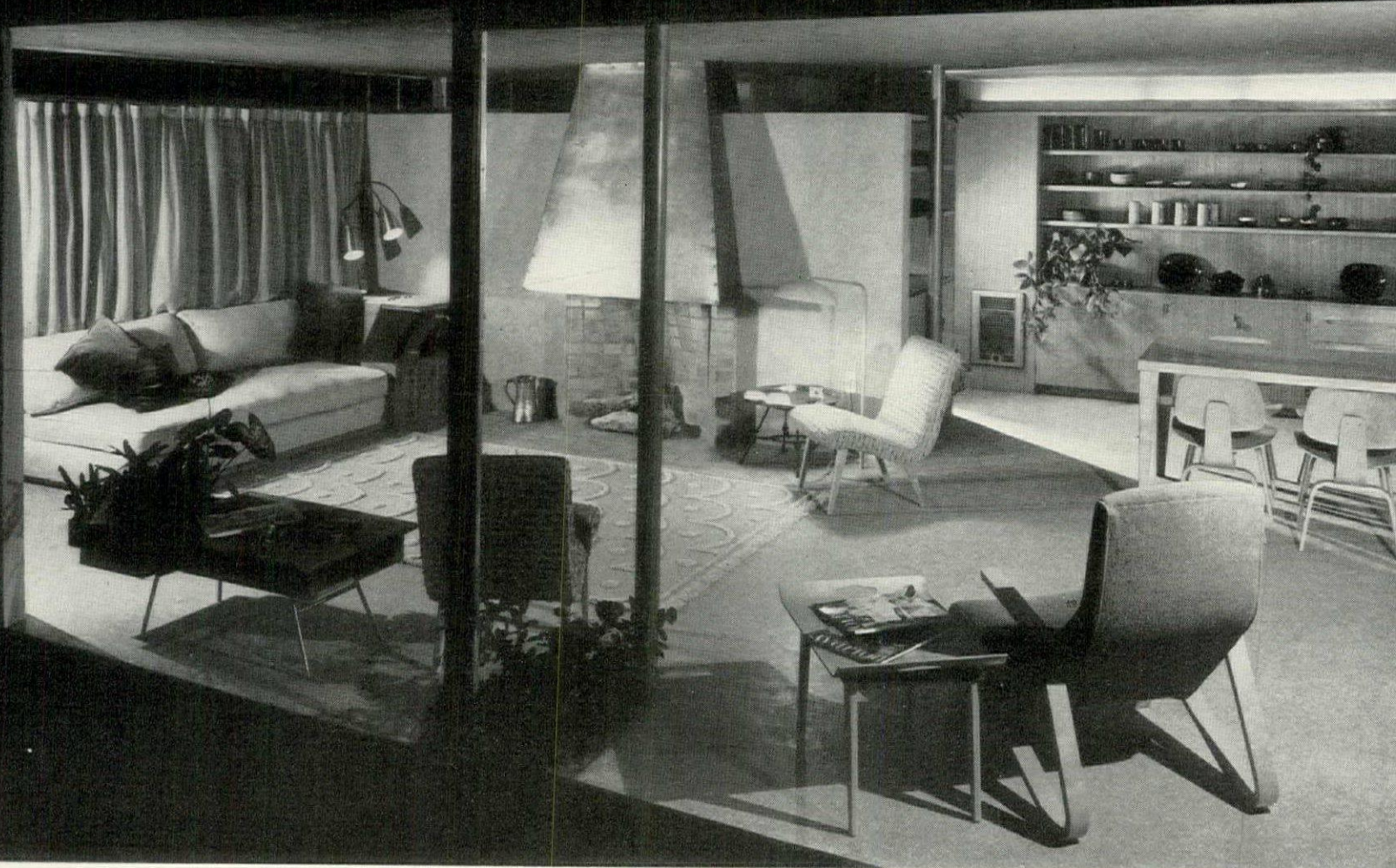

WARMTH IS INTRODUCED INTO WHAT MIGHT OTHERWISE BE A COLD CONCRETE INTERIOR BY MEANS OF WOOD, BRICK AND CLOTH TEXTURES AND A BRIGHT, COPPER FIREPLACE HOOD

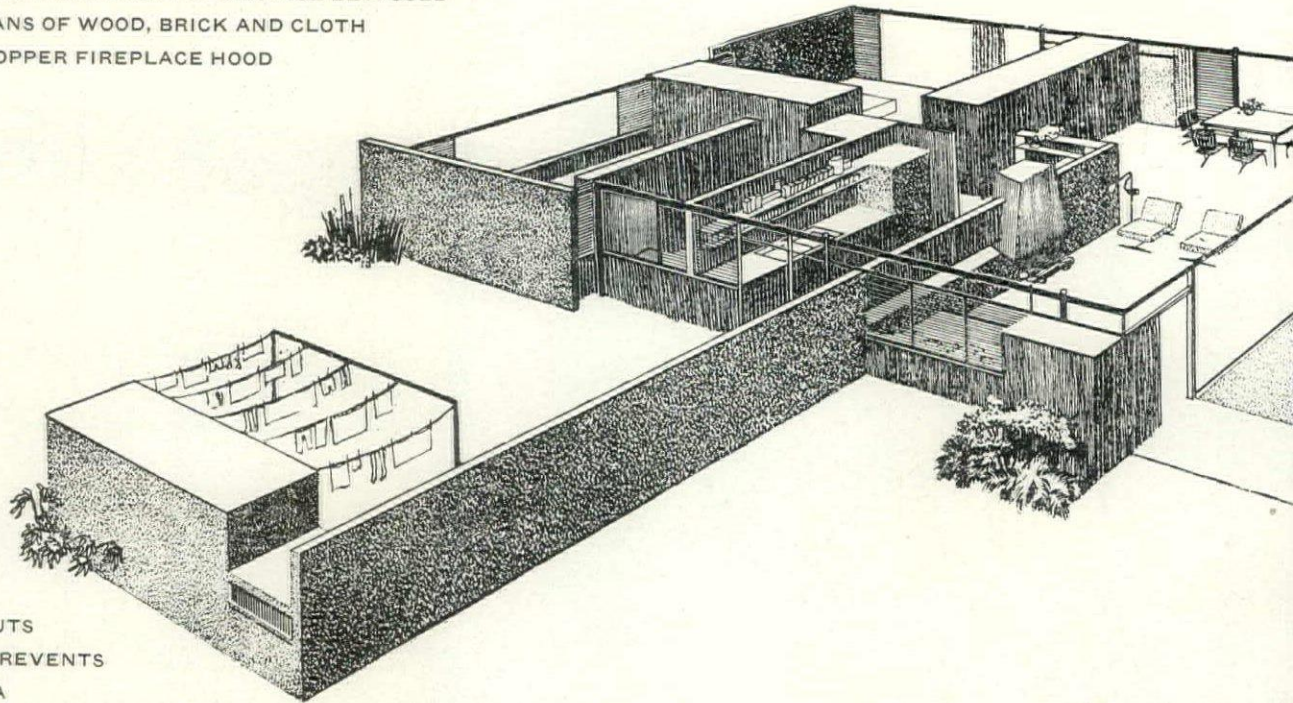

ROOF REQUIRES NO RAISPOUTS BUT SPECIAL GRAVEL STOP PREVENTS WATER FROM MARKING FACIA

Rodney McCay Morgan

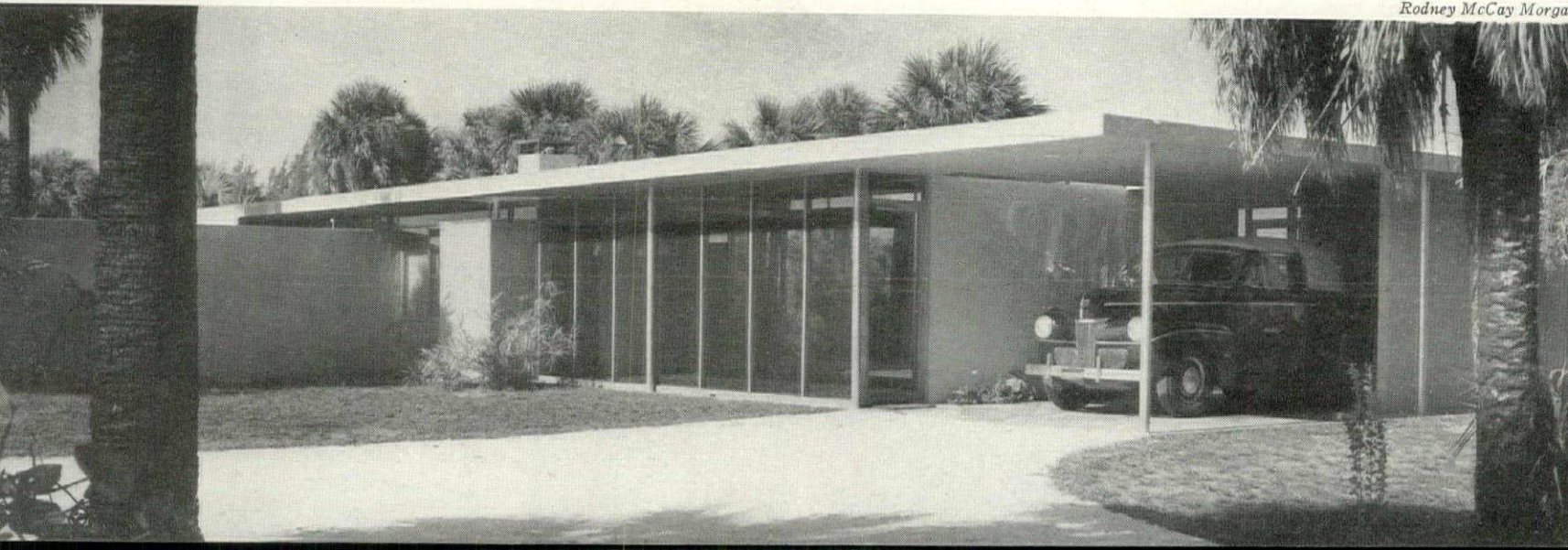

successful experiment in quality design and construction as applied to the medium-priced house field

a joint effort to promote quality construction for small homes, REVERE and the Revere Copper & Brass Co. are sponsoring the building of eight regional houses in different sections of the U. S. The Florida prototype, shown here, is designed by Twitchell & Rudolph, outstanding architectural architects, and built by Lamolithic Industries with their perfected method of monolithic, reinforced concrete construction. The plan of the house is a simple rectangle, chosen by the architects as providing the most for the money—in this case two bedrooms, a large living-dining room, well-equipped kitchen, glassed-in patio, carport and an out-of-house storage hut with concealed laundry yard for \$15,000.

As a prototype house, it is an excellent design since the cost can be reduced even further by eliminating carport, patio and storage-laundry area. Major rooms are sited toward the south and southwest to catch the prevailing breezes and the patio is shut off from the north wind by a long wall extension, an important amenity in the Florida climate. The type of construction is especially interesting and is a major factor in holding the price line. Foundation walls and roof are all monolithic concrete slabs (walls-6 in.; roof-7 in.) poured in modular steel forms, thus eliminating beams and expensive framing. Unlike porous cement block, this concrete mixture is completely dry; mildew-proof; bug-proof; hurricane- and fire-resistant. It appears to be a near-perfect answer to Florida's many tropical building problems, including the ever-present threat of termites which make wood construction a questionable practice. Walls are non-load bearing, an isolated system of lally columns supporting the roof slab. This allows maximum

flexibility of interior partitions. Cross rigidity of outer walls is achieved by the monolithic structure. The poured concrete roof is insulated and surfaced with Vermiculite, a porous, spongy material, and sprinklers are provided to wet it from time to time. This provides an interior temperature comparable to air conditioning but at much lower cost. Floors (4 in. concrete slab and 1 1/4 in. terrazzo) are placed on a 6 in. shell fill which acts as a sponge for water—an important factor since the house is less than 2 ft. above the high water mark. Pouring time on the house was only two and one half hours for walls and roof, 20 minutes for the carport.

WIDE EAVES, PLANTING, PROTECT INTERIOR FROM BROILING SUN

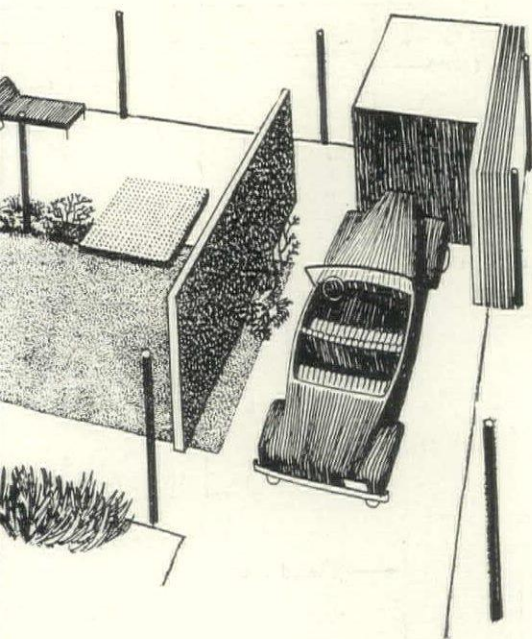

The importance of this experimental building program lies in the fact that it is a voluntary effort by private building to raise the standards of residential design and construction. The Revere Quality Home Institute was created to handle the project and houses sponsored by it will be presented to the public in a nation-wide campaign during the coming months.



Quality Materials

- Framing—#1 fir or pine
- Building Paper—sisalcraft, waterproof, non-tearing
- Exterior Frame Siding—waterproof striated plywood
- Windows—aluminum frames
- Glass—1-4" polished plate, 3-16" sheet glass in ventilating units
- Door Frames—cypress, except for sliding door to porch, which is aluminum
- Interior Trim—cypress around doors and windows, for cabinets and built-in furniture
- Shelves—clear pine
- Storage Walls—striated plywood
- Flooring—Terrazzo is used throughout entire house except in carport
- Roofing—special pitch on concrete slab under vermiculite
- Flashing—16 oz. copper on chimney, between roofs and walls at entrance closet, and as fascia and gravel stop.
- Fireplace and Kitchen Hood—36 oz. copper over steel frame
- Insulation—exterior frame walls, 2" mineral wool; all roofs insulated with 2" vermiculite, cooled by delayed evaporation
- Kitchen—cypress counter tops
- Bathrooms—all fittings, chrome-plated brass
- Plumbing—all water lines without exception are Copper Water Tube; Valves, Brass.

Indoor-outdoor living is possible without accepting the scourge of tropical insects

Throughout the house emphasis is on indoor-outdoor living, but bugs and roaches are efficiently kept outside by fixed glass panes and, where jalousies and sliding wall panels are used, copper screening. The jalousies, similar to Venetian blinds but made of glass, are a tropical necessity, providing adjustable cross ventilation according to the wind strength. Upkeep on this particular house is almost non-existent, since the concrete requires neither plastering, painting nor finish material, inside or out. Only the floor and certain interior partitions have been surfaced, but this is for textural contrasts rather than out of necessity. Aluminum window framing is also impervious to the inroads of tropical weather and insects.

CONSTRUCTION OUTLINE: Foundation—reinforced concrete. **STRUCTURE:** Exterior walls—Sisalcraft paper, Sisalcraft Co. Concrete, cement finish inside and out, Florida Portland Cement Co. Floors—terrazzo. **ROOF:** built-up roofing over reinforced 7 in. monolithic slab. Fabricated by Lamolithic Industries. **INSULATION:** Outside walls—mineral wool, The Flintkote Co. Roof—2-3 in. Vermiculite, The Zonolite Co. **FIREPLACE:**—copper hooded with specially designed steel damper, Revere Copper & Brass Co., Inc. **SHEET METAL WORK:** Flashing—16 oz. copper, Revere Copper & Brass Co., Inc. **WINDOWS:**—special aluminum frames, ABC Steel Equipment Co. **GLASS:**—Pittsburgh Plate Glass Co. **Plastic porch screen:**—Chicopee Mfg. Corp. **WALL COVERINGS:** Living room and bedrooms—concrete. Halls, kitchen and bathrooms—plywood. **PAINTS:**—O'Brien Corp., John Lucas & Co., Pittsburgh Plate Glass Co., Twentieth Century Paint & Varnish Co. **WOODWORK:**—cypress and striated plywood, U. S. Plywood Corp. **HARDWARE:**—Schlage Lock Co. **ELECTRICAL INSTALLATION:** Wire—General Electric Co. Conduit—National Electric Products Co. Switches—Hart & Hegeman Electric Co. Fixtures—Kurt Versen Co., General Lighting Co., Century Lighting, Inc. **KITCHEN EQUIPMENT:** Range, refrigerator, dishwasher and Disposal—General Electric Co. Cabinets—Kitchen Maid Corp. **BATHROOM EQUIPMENT:**—Crane Co. Toilet—W. A. Case & Sons Mfg. Co. **BATHROOM TUBING:**—Revere Copper & Brass, Inc. **HEATING:**—electric panel heaters, Thermador Electrical Mfg. Co.

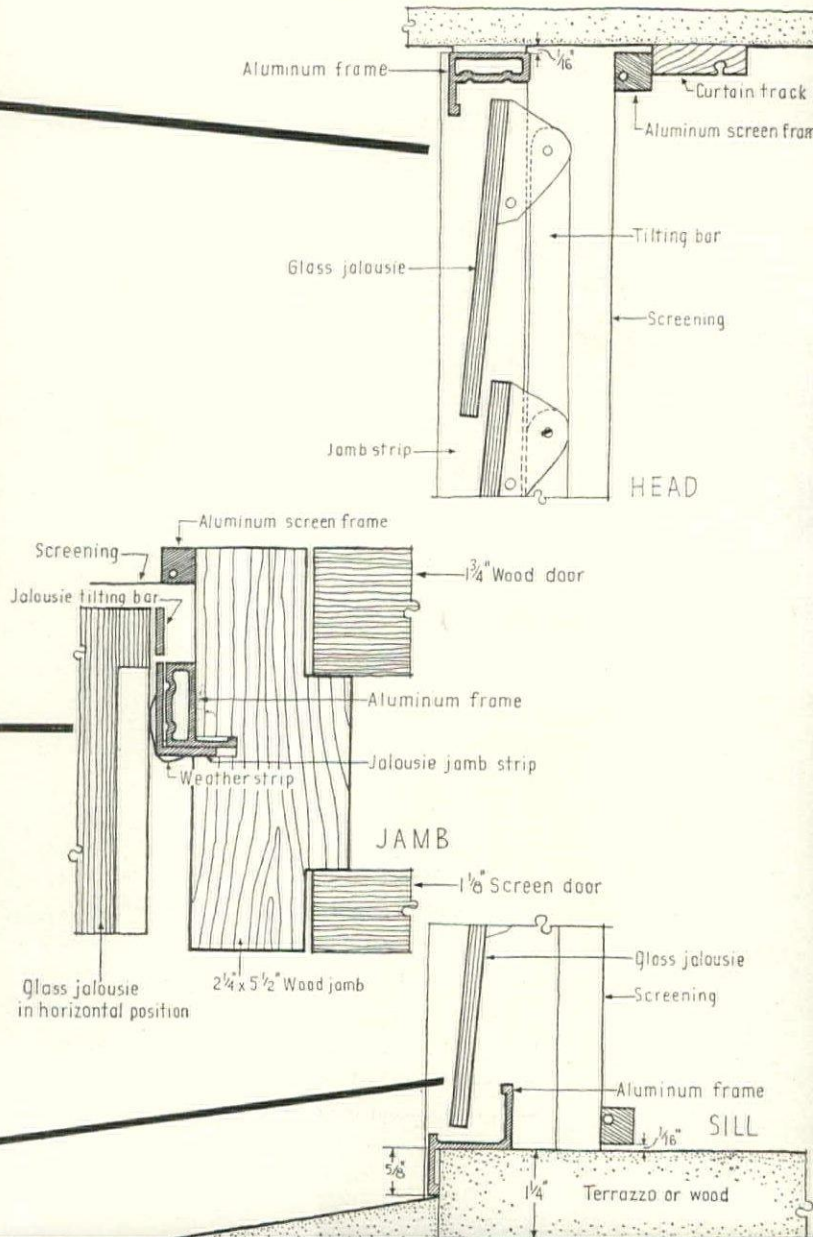
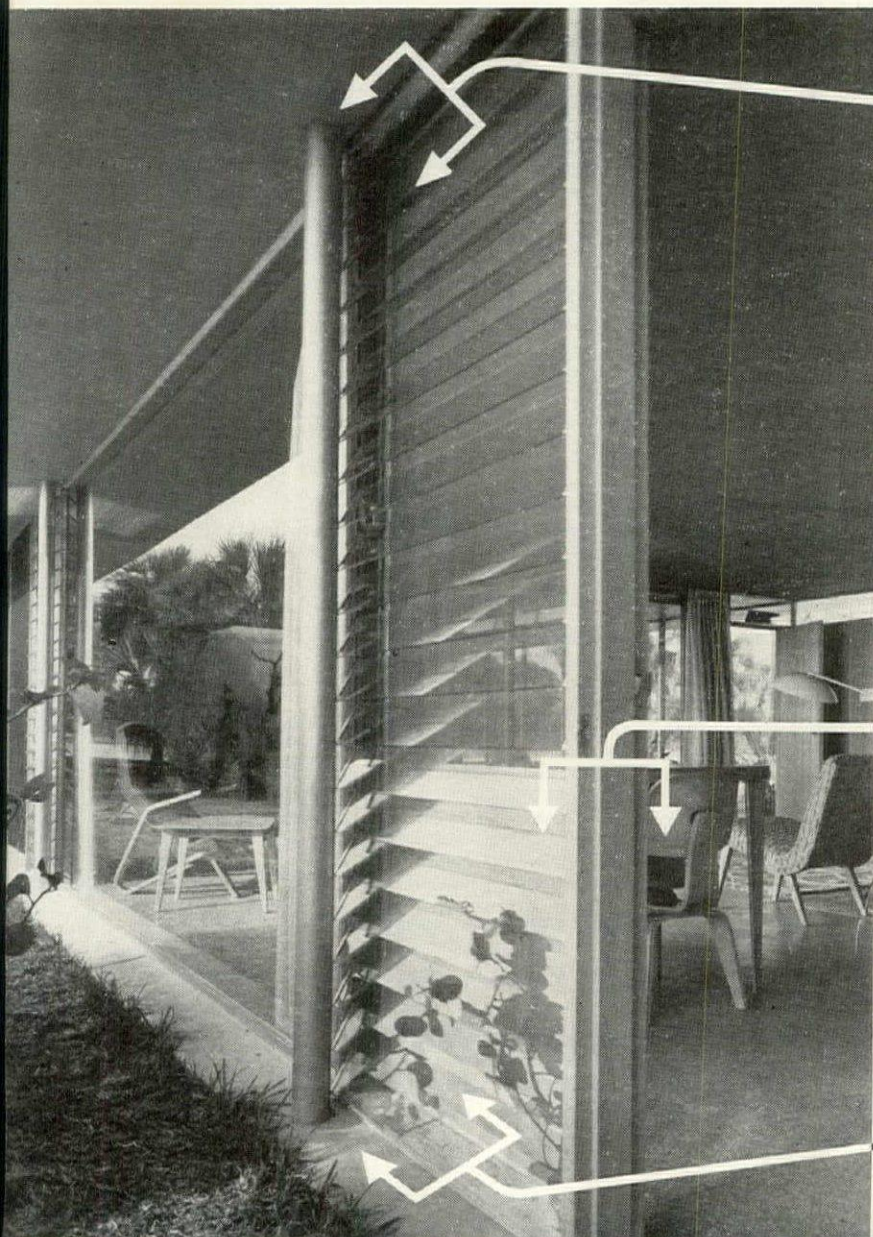
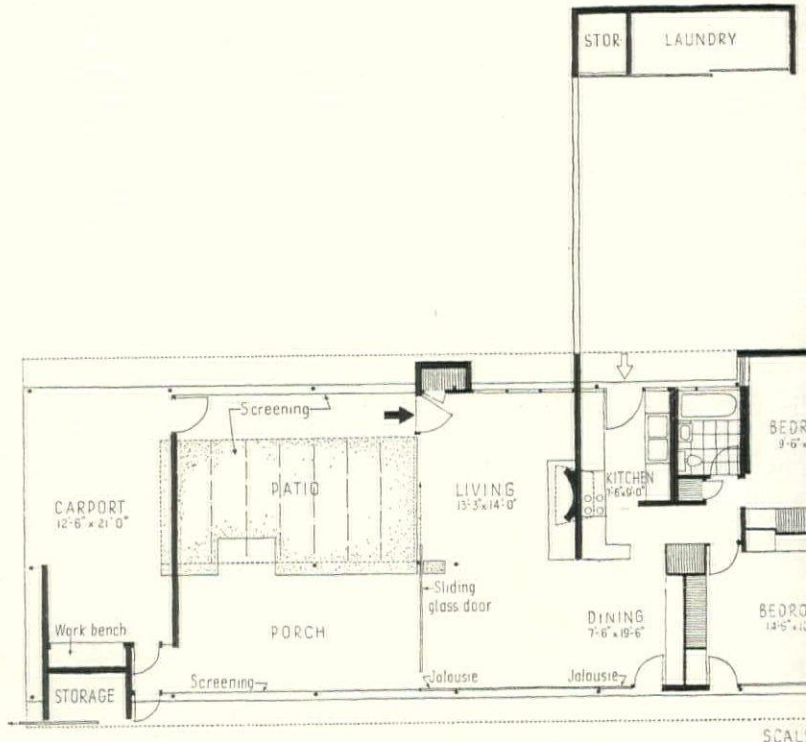

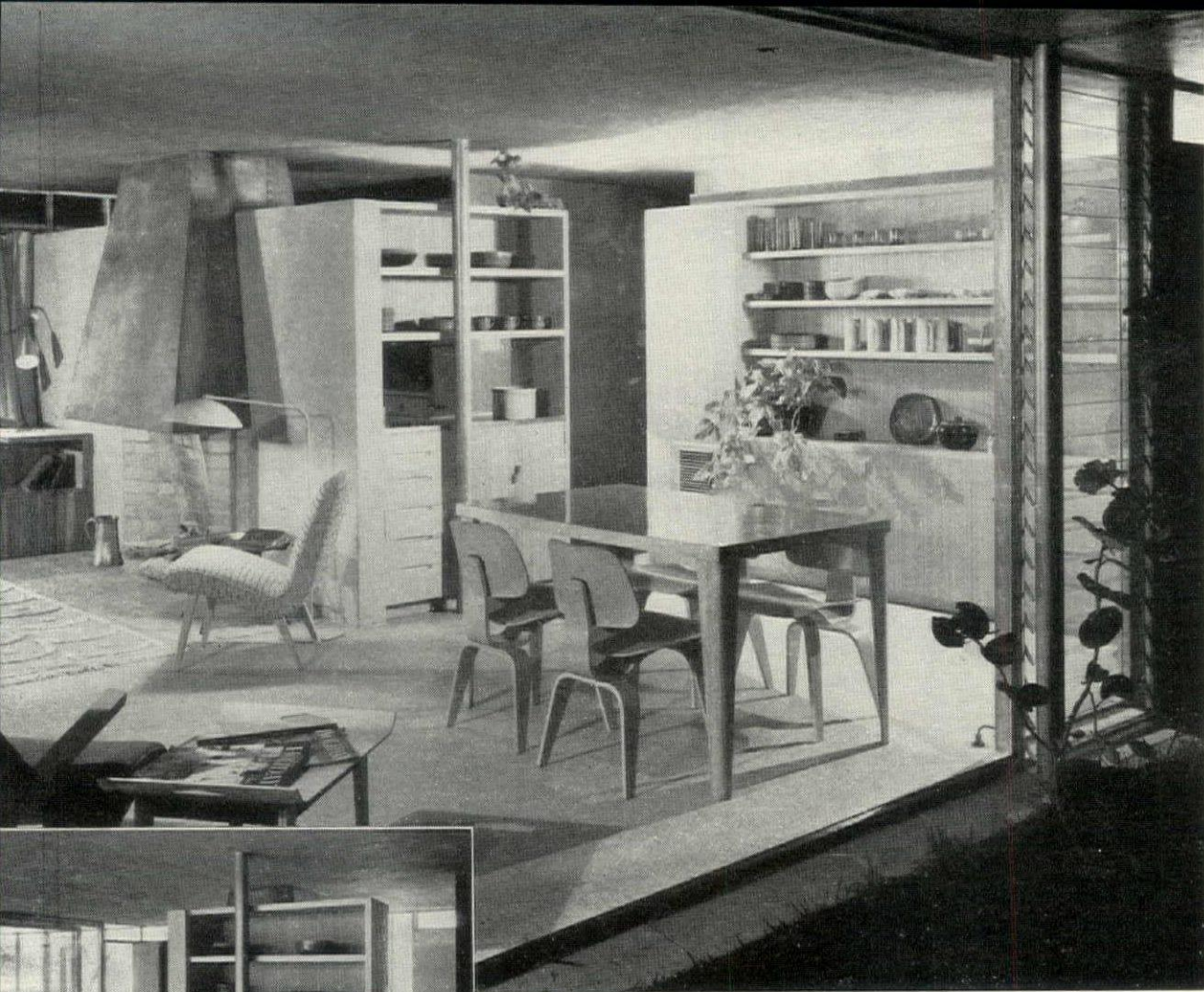

L-SHAPED PARTITION consisting of fireplace and cupboard unit screens kitchen from dining area without expense of door and full-height walls. Living area can be curtained off to provide extra sleeping space.



STORAGEWALL PARTITIONS are used generously throughout the house in lieu of conventional closets. Except in the kitchen and bathroom all walls are faced with striated plywood as below.

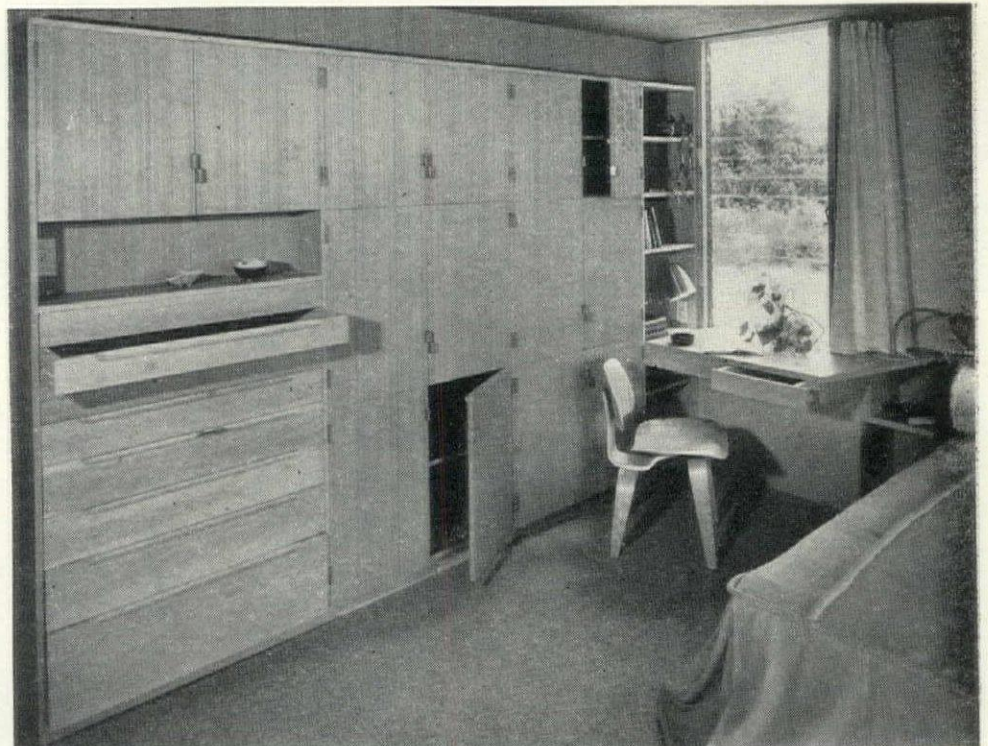
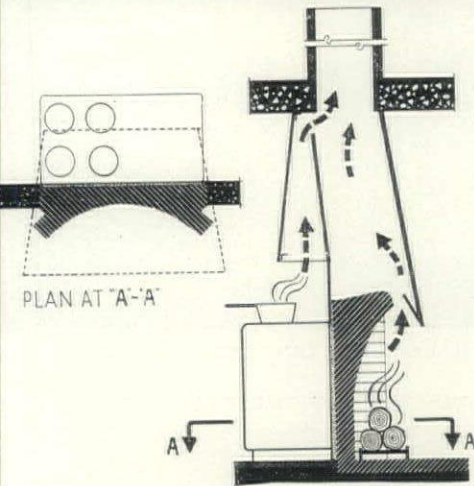

Rodney McCay Morgan



DOUBLE DUTY COPPER HOOD serves both fireplace and kitchen stove, carries cooking odors up the chimney. It also acts as a radiant heater, providing an estimated increase of 40 per cent in the heat supply. To right of hood is serving window for convenient passage of food and drinks to living room.

Four concrete beach houses provide

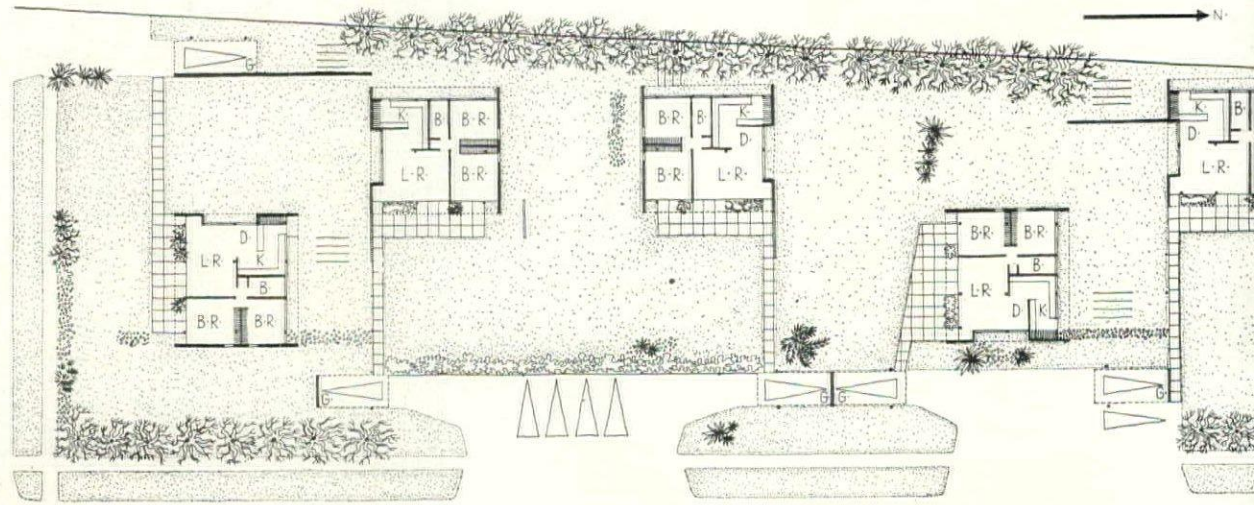

Photos:

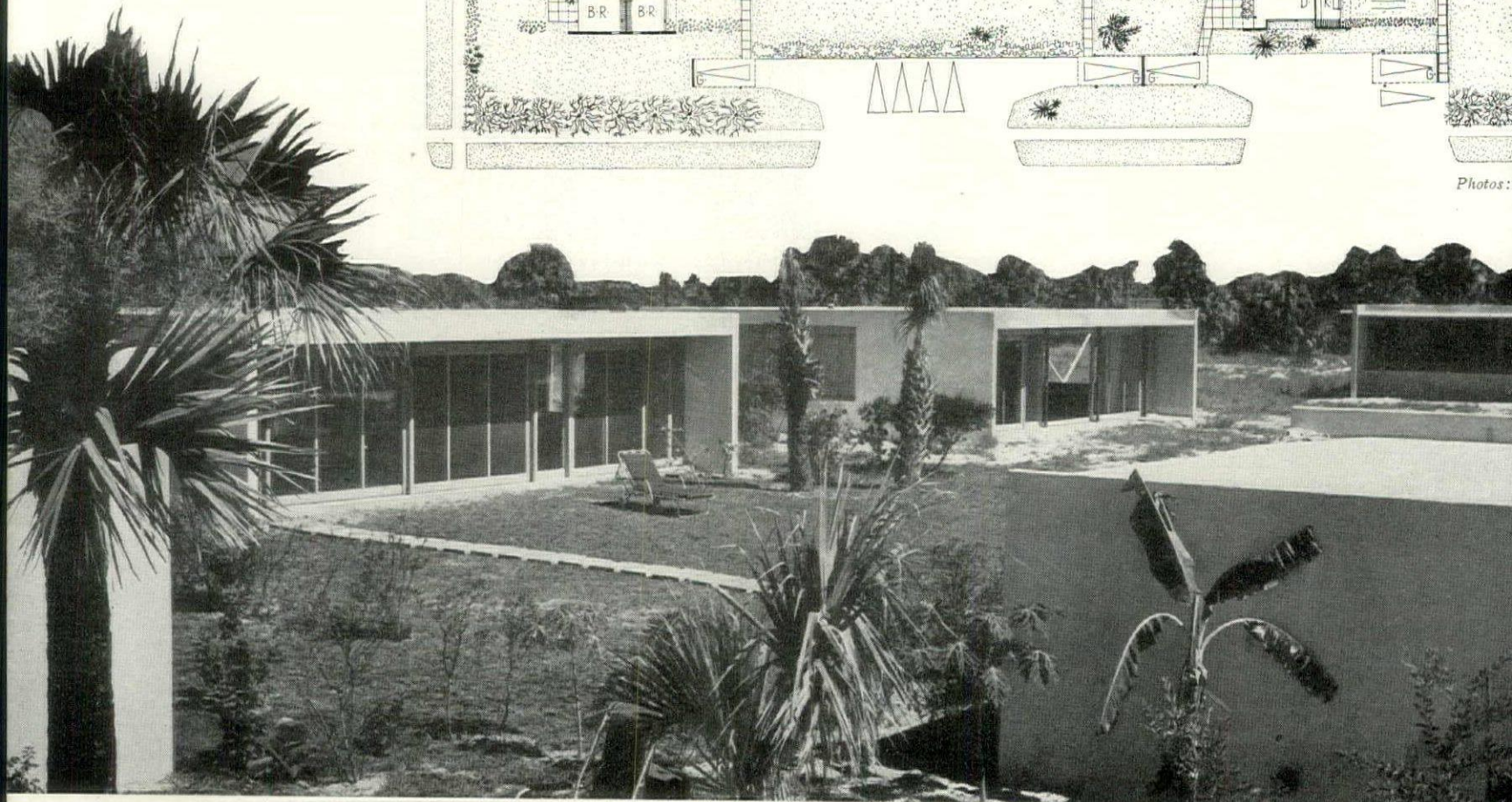

FRONT VIEW OF HOUSES SHOWS GROUND TO CEILING GLASS WALLS SHADED BY OVERHANGS. ROOFS HAVE BEAMS OMITTED IN REVERSE HOUSES

TO CURE CONCRETE, FORMS ARE LEFT ON THE WALLS FOR 48 HOURS AND ON THE ROOF FOR 8-10 DAYS

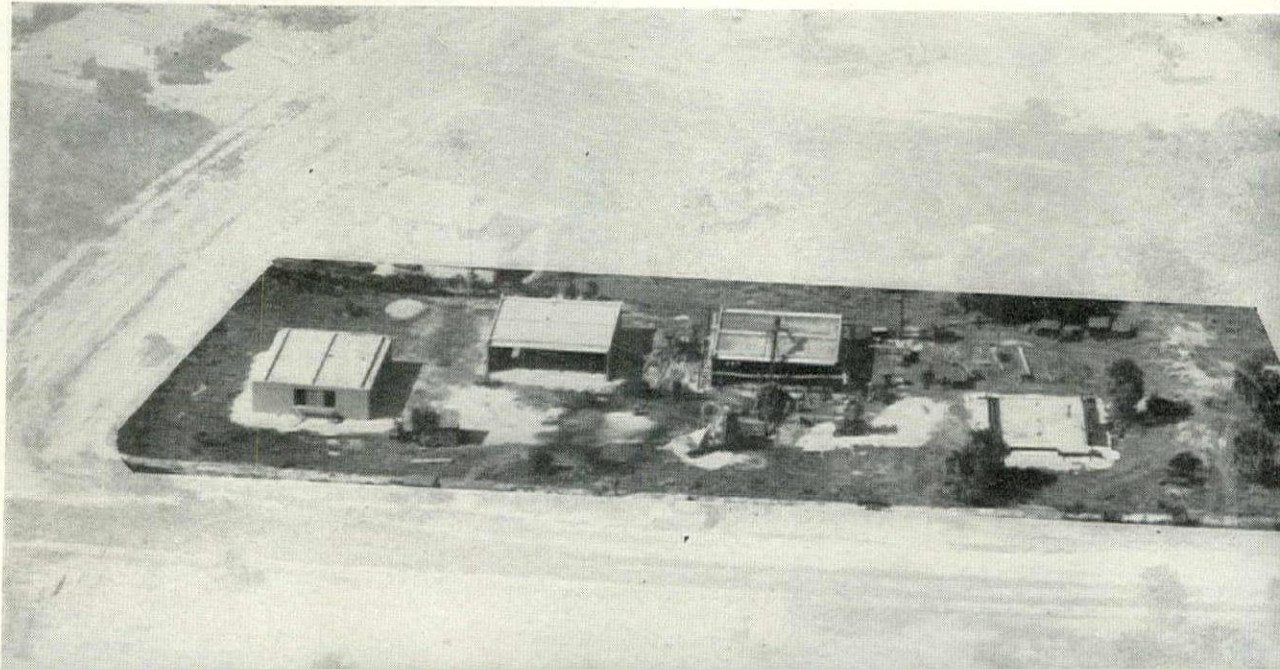

lmarks of luxury on a small scale

LOCATION: Sarasota, Fla.
RALPH S. TWITCHELL, Architect
PAUL M. RUDOLPH, Associate
LAMOLITHIC INDUSTRIES, Builders



In addition to the Revere house, Lamolithic Industries has recently completed a group of four less expensive homes as a speculative building venture. Designed by the same architects in the same monolithic concrete, they show, on a smaller scale, equally fine planning and detail. For instance, the roofs of these houses provide temperature control similar to that of the Revere house, but they have been worked out somewhat differently. The concrete slab is surfaced with a membrane waterproofing topped by 6 in. of shell sand. A water level of 3-4 in. is maintained in this layer of surfacing. This not only cools the interior, but keeps walls and roof at a uniform temperature, thus preventing cracks between members which would appear if they were heated at different rates. Layouts are based on a square, but interior space has been arranged with enough irregularity to prevent the feeling of being trapped in a box. Two bedrooms, spacious kitchen, living-dining room and paved terrace are provided for a building cost of only \$8,900. Selling price, including a lot 72 x 120 ft., is \$10,500, but the builder estimates that, having learned by experience, he can turn out the same house and lot for \$9,000 with an adequate profit. On a rental basis he figures a net return of 14 per cent, factors in this high yield being the absence of upkeep and low insurance rates due to fire-proof, hurricane-proof construction.

EAR VIEW SHOWS WIDE PANEL WINDOWS WHICH OPEN UP THE KITCHEN AND BEDROOM, ALLOW EXCELLENT THROUGH VENTILATION

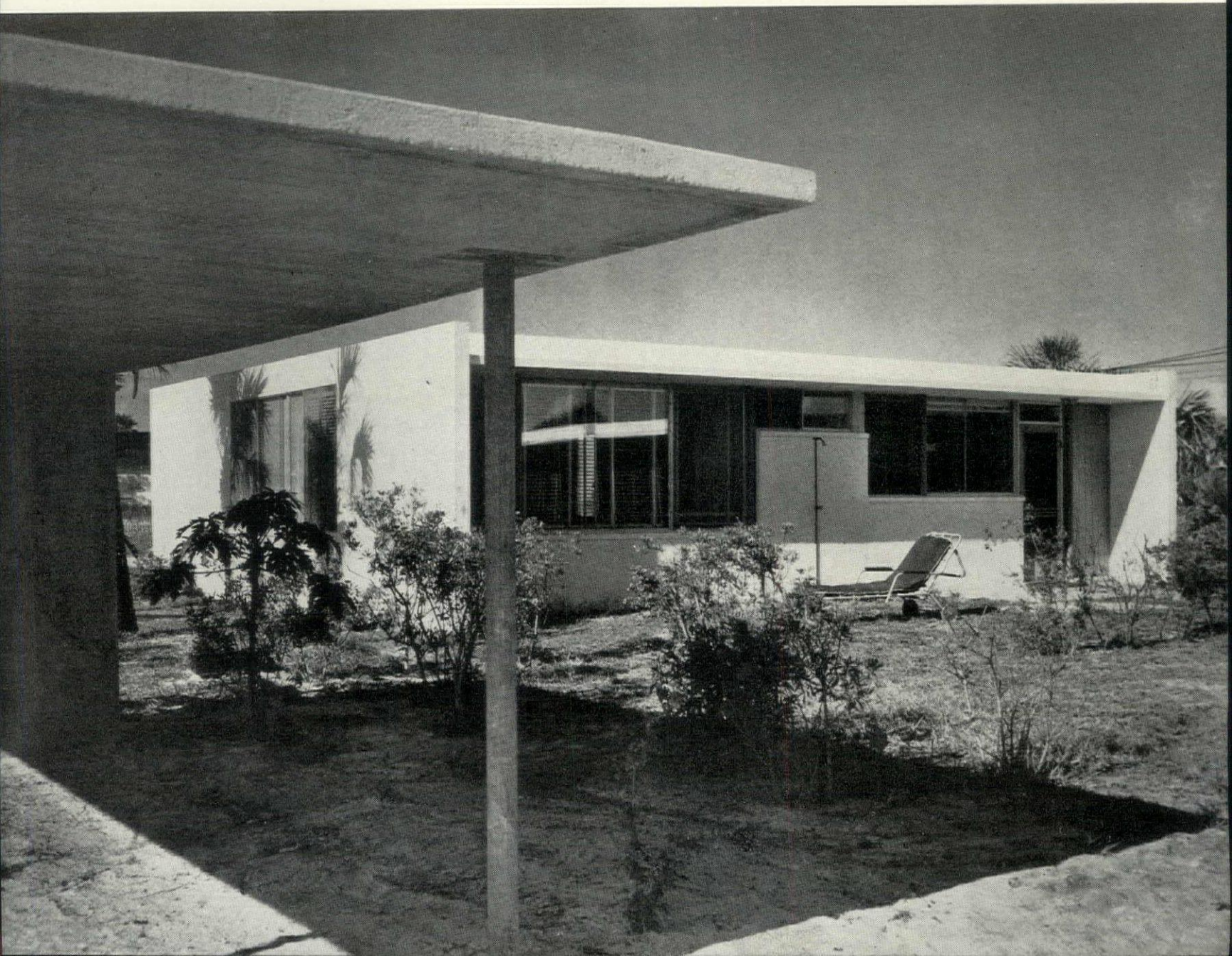

Meticulous planning and landscaping plus low upkeep are sales hooks

Steinmetz

Since these houses were the builder's first venture into contemporary design, he approached them with some trepidation. Informal siting and landscaping and the large glass areas which open up interiors at both front and rear, proved particular stumbling blocks. In a letter to the architects he confessed: "You may think of us as moral mice and not men at all, but it has been quite a struggle to go through with the plan as originally contemplated, many timid voices having been raised against it." His fears were quieted with completion of the houses. Over 100 visitors came, looked and demanded that he start building similar homes for them at once.

CONSTRUCTION OUTLINE: Foundation—reinforced monolithic footing with integral reinforced slab. Integral waterproofing, Lamolithic Industries. **STRUCTURE:** Exterior walls—reinforced monolithic concrete, stucco outside, plastered inside, Lamolithic Industries. Floor construction—monolithic slab. Lamolithic Industries, asphalt tile finish, Thomas Moulding Floor Co. **INSULATION:** Roof—"Bengal" roofing, controlled level of water in shell, cooling by delayed evaporation, Lamolithic Industries. **WINDOWS:** Sash—aluminum sliding, ABC Steel Equipment Co. Glass—polished plate, Pittsburgh Plate Glass Co. **FLOOR COVERINGS**—asphalt tile, Thomas Moulding Floor Co. **WALL COVERINGS**—concrete or plywood, U. S. Plywood Corp. Bathrooms—glazed ceramic tile. **PAINTS**—Reardon Co. **WOODWORK:** Cabinets—fabricated by Lamolithic Industries. **HARDWARE**—Knape & Vogt Mfg. Co. and Henry Stephen Harvey. **KITCHEN EQUIPMENT:** Range—Tappan Stove Co. Refrigerator—Servel, Inc. Sink—Crane Co. **PLUMBING:** Soil and vent pipes—cast iron. All other lines including gas and fuel—copper tubing, Revere Copper & Brass, Inc. **WATER HEATER**—General Electric Co.

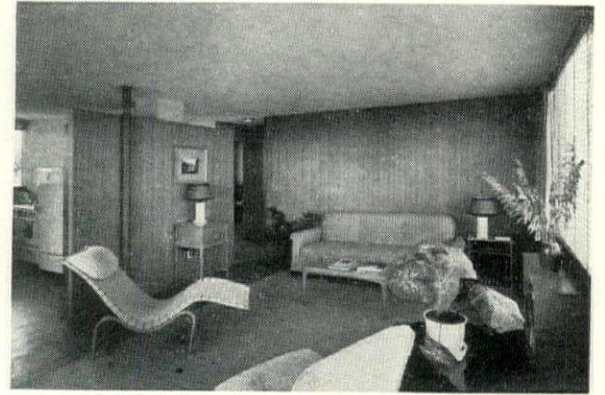
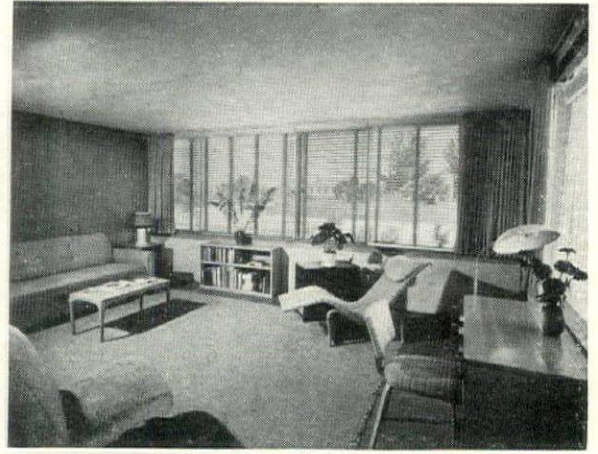

KITCHEN AND DINING AREA ARE EXTREMELY OPEN IN PLAN (SEMI-PARTITIONS AND NO DOORS) BUT VISUALLY SEPARATE

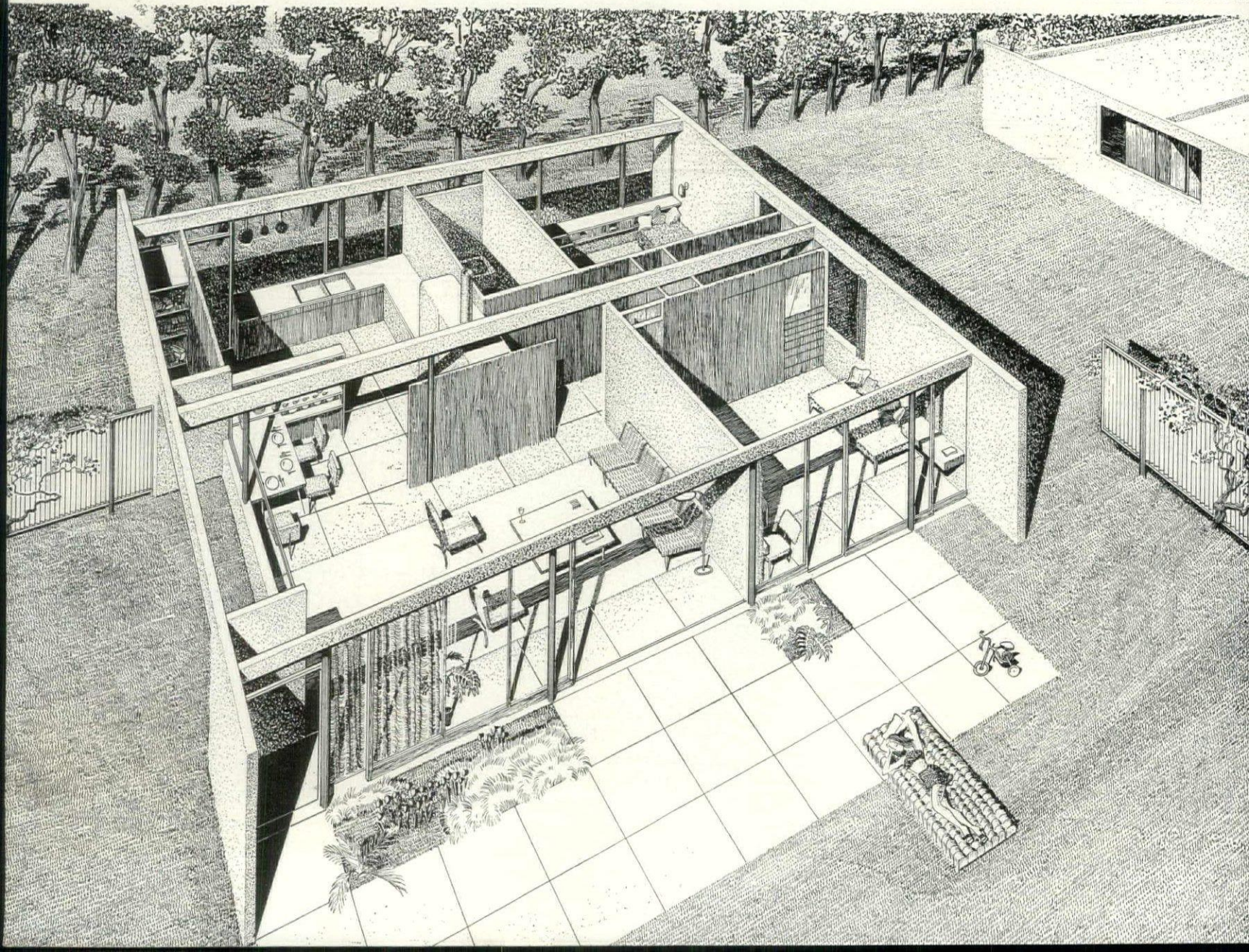

PRODUCTS AND PRACTICE



LAMOLITHIC STEEL FORMS not only facilitate fast and economical construction
but here build a house which is an example of proper concrete design practice

The Lamolithic house varies considerably from the increasingly familiar pattern of quick-cured concrete houses with which many simi- minded inventors are seeking to ease the U.S. housing pinch. Lamolithic is better than most of them, not only in design of the metal forms but by measure of theoretical construction advances. In the Lamolithic method, the aim is more than to meet old structural standards with a new, faster, cheaper method of modular form work, which is the extent of the prohibition of many other new concrete house-builders. Lamolithic goes further, to push some of the inherent properties of concrete construction to their logical fruition.

The most obvious of these attempts to do more (than equal frame or masonry construction with a faster formed material) is the recognition of the insulated concrete slab as a good roof. Other poured concrete houses developed recently have gone to very interesting, try muscle-bound attempts to use concrete in roofs and make it look like something else. In the conservative shadow of FHA, some abandon concrete above the plate line, and

roof with other materials. Lamolithic uses similar forms on walls and roof, and pours a rigid shell, with a few pipe columns to help the steel reinforcing in the roof. Beyond that, the flatness of the level slab roof is used to advantage to hold a shell of water-retaining insulation which dissipates by evaporation a great deal of the heat of the severe Florida summers. (See illustrations on next page).

The Lamolithic system was originally inspired by research of famed inventor Thomas A. Edison into the possibility of mass production of concrete houses. The late J. E. Lambie, a founder and half owner of General Motors foreign division, produced the equipment to realize Edison's objective, working out and producing a modular system of light-weight forms and automatic mixing and conveying machinery. Present head of Lamolithic Industries is J. E. Lambie Jr., son of the founder. The original plant and techniques, now 25 years old, have been adapted to contemporary usage. The module of the forms remains 3 in., with lengths varying from 6 in. to 6 ft., made to a tolerance of 1/64 in.

Steinmetz

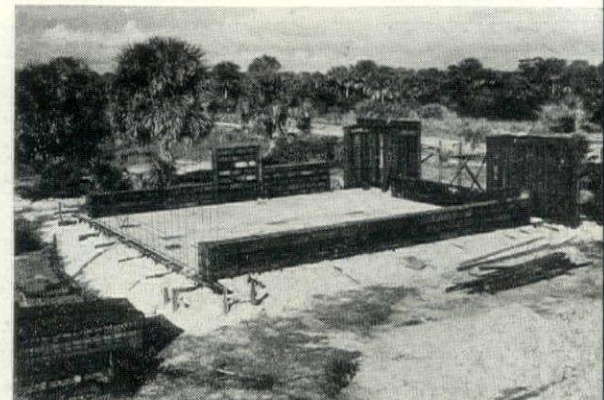

Forms being erected around completed floor slab

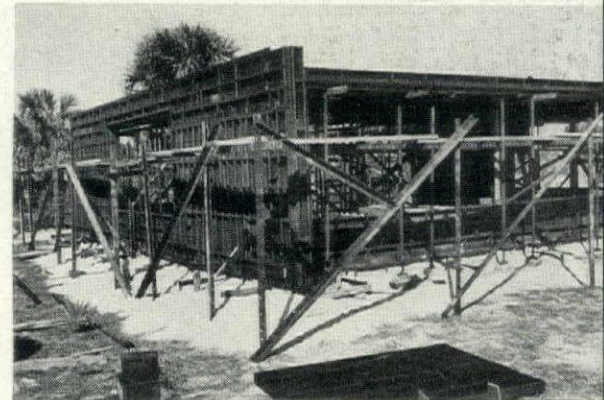

Formwork finishes; pouring — below — is rapid



LAMOLITHIC INDUSTRIES HOUSE uses roof with beams projecting upward, and a bed of coral shell pooling water atop sl

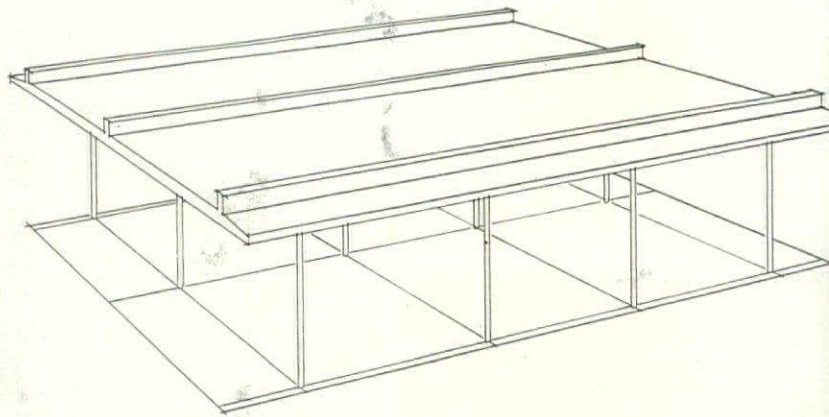
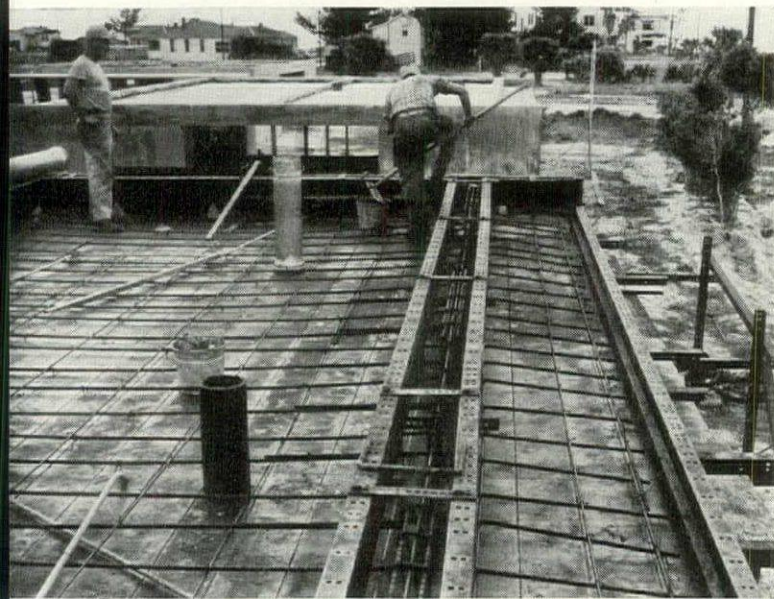

BEAMED ROOF SLAB, represented schematically above, is first of these two methods which keep ceiling surface of the slab an unbroken flat surface. On roof, the 3 in. water level is limited by drains down into wall sections which start at the 3 in. level above the built-up roofing which beds the crushed coral. Beam reinforcing is not shown in drawing. The slab reinforcing bars were bent by foot after placement.

REVERE INSTITUTE HOUSE has flat slab roof with all reinforcing contained in the slab, and a layer of wet vermiculite to

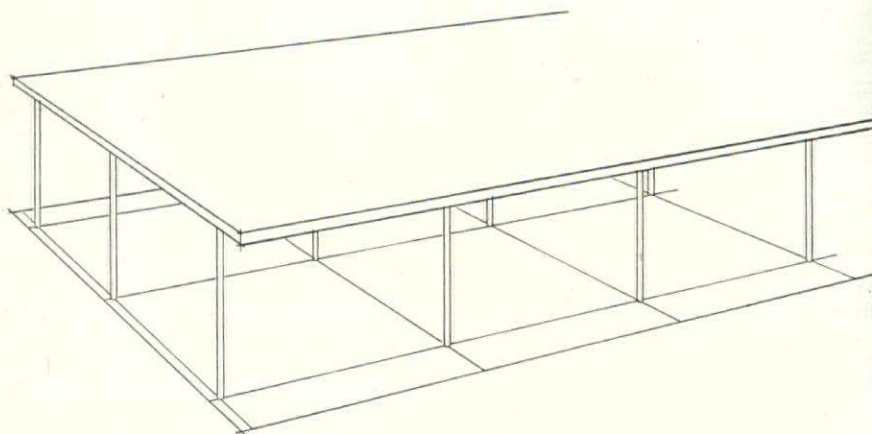
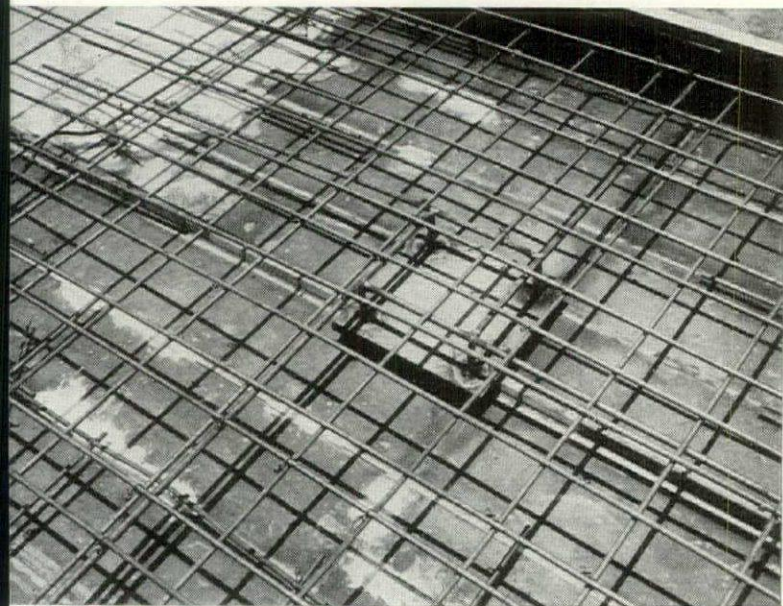

FLAT SLAB is kept flat at ceiling surface by setting column head and plate up an inch into slab. Welded assembly above holds reinforcing bars tied together in grid. Vermiculite mix on built-up roofing has a 3 in. pool of water with drains to prevent higher level, and a built-in sprinkler system to ensure maintenance of the water level. Floor slab in each building was cast in single operation.

In a design sense, the Lamolithic system should be welcome to the many architects who have long sought a cheap, fairly simple method of setting a slab roof directly on lally columns, without the elaboration of visible beams. Two different systems have achieved this same result in the two Florida designs poured in Lamolithic metal forms.

In the Lamolithic Industries' own house, there actually are reinforced concrete beams supporting the slab, but, instead of supporting the slab from below, they project upward and the slab is hung from them. In the Revere House, the reinforced slab is entirely flat, with

the steel reinforcing rods arranged to allow the pipe columns to grow right into the ceiling.

Interestingly enough, and somewhat debatable in design, is the fact that there is more steel in the beamed slab than in the smooth slab.

Insulating materials in the two roofs also differ, but are equivalent in method and operation. Four to six inches of crushed shell are used to hold water on the Lamolithic roof. On the Revere roof, the same insulating task is done by a 3 in. bed of vermiculite mix (8 parts of vermiculite to one cement). The Revere house also has a sprinkler system to maintain the roof wetness against droughts.

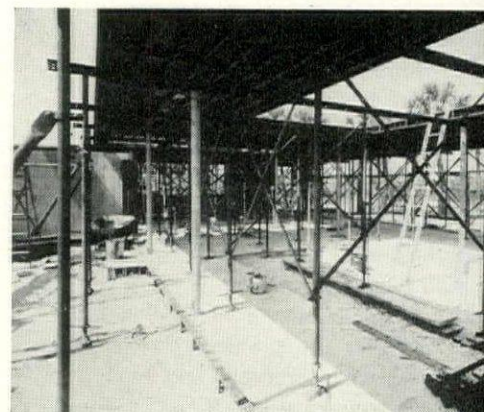

Forms for Revere Institute house, with steel scaffolding. Caps of columns project upward beyond forms. The roof slab is poured around them.

for hot weather protection

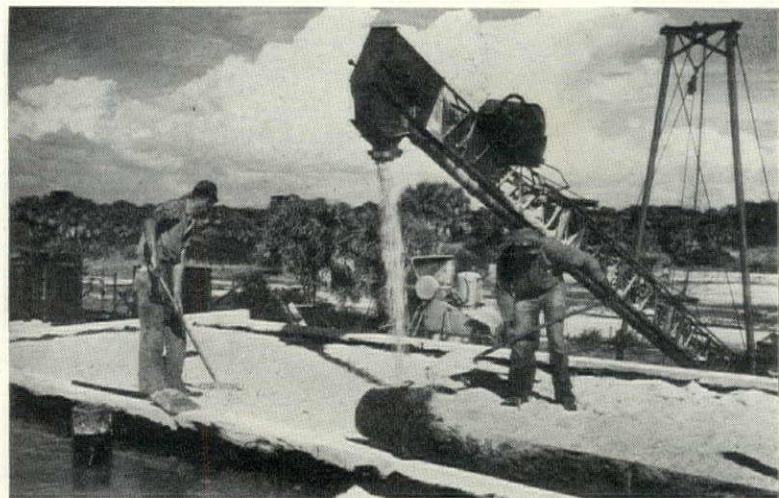
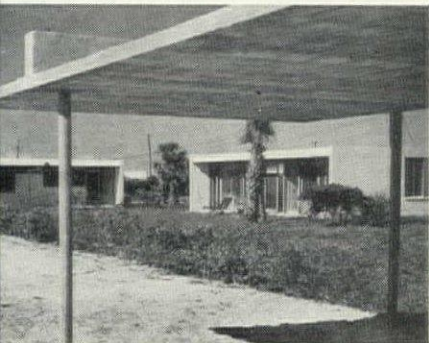
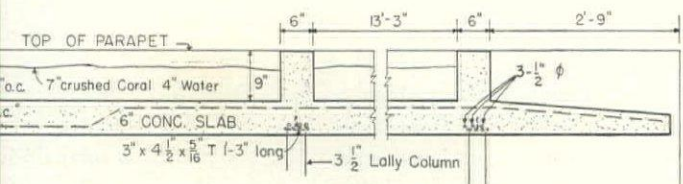

CRUSHED CORAL is raked into place on top of Lamolithic house roof. Layer of insulation, applied directly over built-up roof, is held in place by its own weight and composition, and needs only to be spread, not tamped down or set.

the same insulating job

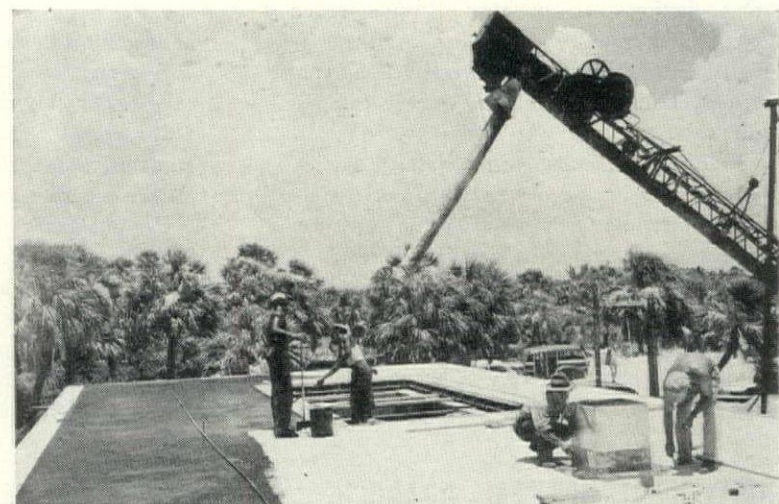
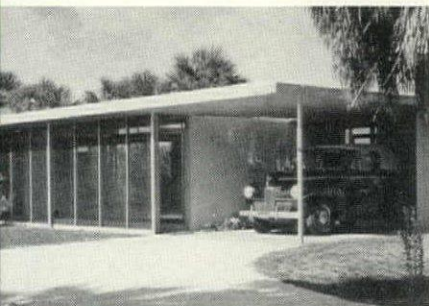
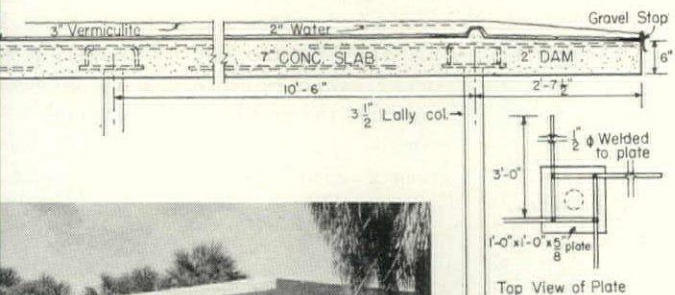

VERMICULITE is applied in mix, eight to one, with cement for binder. Note the jets of the sprinkler system, whose supply pipes are set into the vermiculite. Control is manual. When temperature rises, sprinkler is turned on.

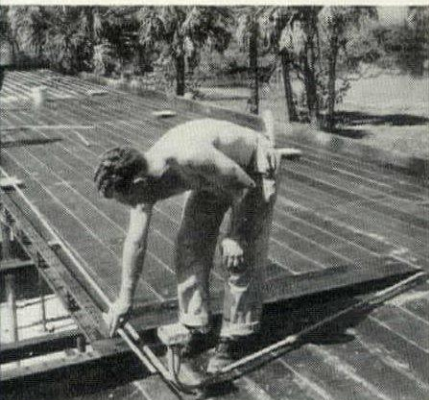

Conduits are installed on steel roof forms. After the joints between adjoining forms are sealed. Note plates which cap lally columns.



Reinforcing grids are put in place over welded assemblies atop column heads. The midspan rods are at same 1 in. level as plates of columns.



Pouring of roof slab is done with a specially designed, portable mixing and pouring rig which is built for great speed and ease in handling.

EUROPEAN WALL AND FLOOR COVERING with paper sulphite base made as tile or poured in place to be introduced in U.

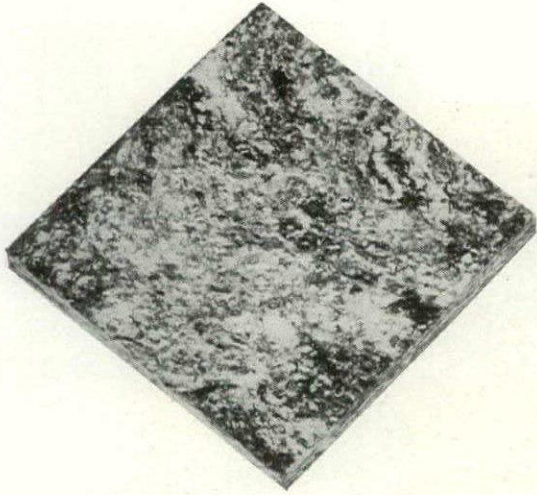

Makers of Alpan, an inexpensive European wall and floor covering, have secured patents in this country, and are moving to make their product available on the American market. Produced and used for more than twelve years abroad, Alpan can either be poured in place, then polished, or prefabricated and applied as tile. The basic raw material is paper sulphite, its principal source old newspapers. The binding agent is a patented composition of plastics and magnesia, including waxes. The finish is self-maintaining.

Alpan can be cast in nearly any color, and is available abroad in solid colors and a number of marble-like designs which carry through the thickness of the tile. The finish is fairly hard, and warm, somewhat similar to asphalt tile or linoleum. The material wears well, does not shrink or expand, and has good resistance to acids. Average cost in Europe today, according to the manufacturer, is about 40 per cent that of other covering materials with equivalent qualities. He estimates production cost in the U. S. at about 11 cents per sq. ft.

AIR-ENTRAINER FOR CONCRETE cuts water necessary for workable mix, reducing bleeding without loss of workability

A new air-entraining agent for concrete reveals qualities under test and in practical field use which indicate large value in wide areas of concrete construction. The entrainer, Portite, is a fluid which is added to concrete mixes in doses of 4 oz. to the bag of cement. The resulting reduction of the quantity of water needed for a fluid, workable mix, has averaged as high as 16 per cent under severe testing conditions. Finishing time also has been cut considerably.

Practical advantages of the water reduction agent start with the most obvious one, reduction in bleeding to the point of non-existence, a great advantage particularly in lean mixes of concrete. Workability of the mix is retained with much less water, leading directly to another big factor—possible portability of mixed batches of some concrete without agitation in transit. In tests in Newark last winter three

batches of 5½ bag concrete, one plain, one with 4 oz. of Portite added, one with 8 oz. Portite, were mixed simultaneously with slumps under 4 in., then loaded on a truck in drums and driven in city traffic for a half hour, with an additional 20 to 30 minutes consumed in standing time before and after hauling. Examined after the tests, both Portite mixes were still workable, but the plain mix had—as expected with such treatment—puddled, with a film of water at the top, and had packed to an extent that it had to be picked loose. The Portite concrete could be scooped out by hand.

Use of air entraining agents like Portite in lean mixes with light enough aggregate would come as a boon to a contractor who had limited mixing equipment and a number of widely separated jobs in progress at the same time.

Compressive strength of lean concrete is also upped markedly by addition of the air-

entraining agent. In mixes between three and four bags of cement to the cubic yard, the results gave plain concrete a rating of 1,700 lb. per sq. in. after the 28 day set. Four bags of Portite concrete did 2,193 lb. per sq. in. The advantage fades when the concrete mix is made bulky as six or seven bags to the yard. The 8 oz. dose of Portite showed little advantage in strength over the 4 oz. portion, but did demonstrate that the overdose is not harmful.

In the lean mixes, Portite is a good water proofing agent, and the lesser amount of shrinkage acts to increase bond to steel or other reinforcing materials considerably. Priced in New York at \$2.75 per gallon for large quantities, Portite cost averages about 6 cents per bag of cement on the job. The cost is estimated by its distributor to be wiped out in the increased yield fostered by the entrainer.

BRITISH STRUCTURAL BOARD a sawdust and resin composition, manufactured by small, completely automatic unit

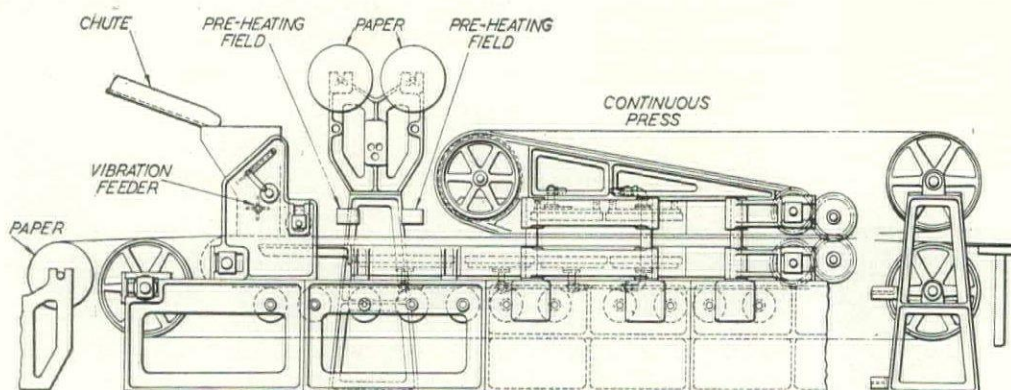

Another new machine for producing structural board from waste material has been developed in England in the continued search for processes by which to manufacture "man-made lumber." The B.A.R. process, for making British Artificial Resin Board, is consolidated into a single automatic machine which includes a conditioning plant, a blender, a loading hopper, a conveyor belt, a high frequency heating

field, a pressure chamber with infra red conduction heating, and an adjustable automatic cutter. Raw materials of the structural board are sawdust and cresol or phenol-formaldehyde resin. Also manufactured is a core material, which is semi-cured and only slightly compressed, to be further compressed when surfaces are applied. Note density variation at core and near surfaces in photograph.

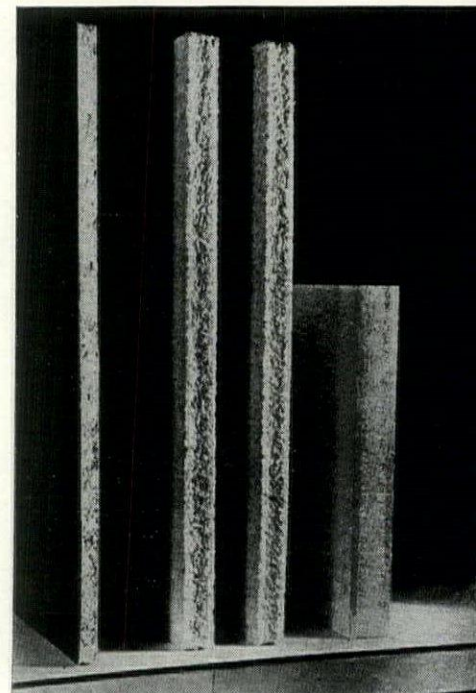

You'll like **Ro-Way** 3-Way Service

1. Installation that's right
2. Operation that's right
3. Maintenance that's right

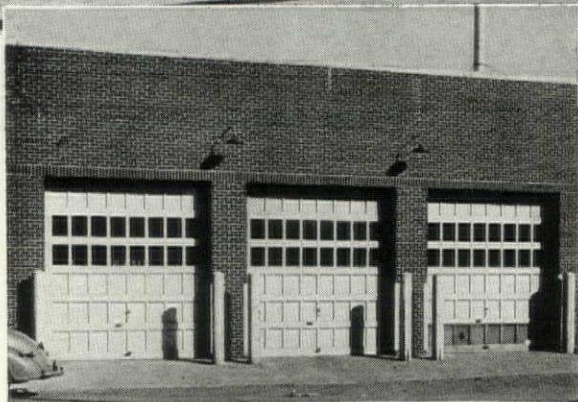

Here's how Ro-Way makes sure!

Installation. Ro-Way distributors are located in all principal cities. Many of them had "the pick of the field", and their choice was Ro-Way. We, too, had a choice of distributors. We think we chose the best. They value the Ro-Way franchise. They operate crews of experts who have the same pride of installation that we have in Ro-Way Door construction.

Operation. Each Ro-Way Door, whether installed on an industrial, commercial or residential job, is designed to give long-time service. We build them complete in our own plant—even to the friction-reducing track and the power-metered springs. Here each part is quality tested and service tested for extra performance.

Maintenance. Ro-Way's national network of selected distributors is always on the job. They give the kind of service you appreciate—if service is ever needed.

Consult your classified telephone directory or write for distributor's name. See our catalog in Sweet's.

ROWE MANUFACTURING COMPANY
942 Holton Street, Galesburg, Illinois, U. S. A.

Amazing new Ro-Way Residential Door requires only 2½ inches of headroom! Ro-Way's latest achievement—the new Model 21 4-section overhead type door. Now in production. Write for details.

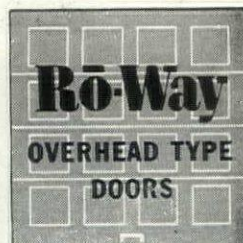

There's a RollWay for every Doorway!

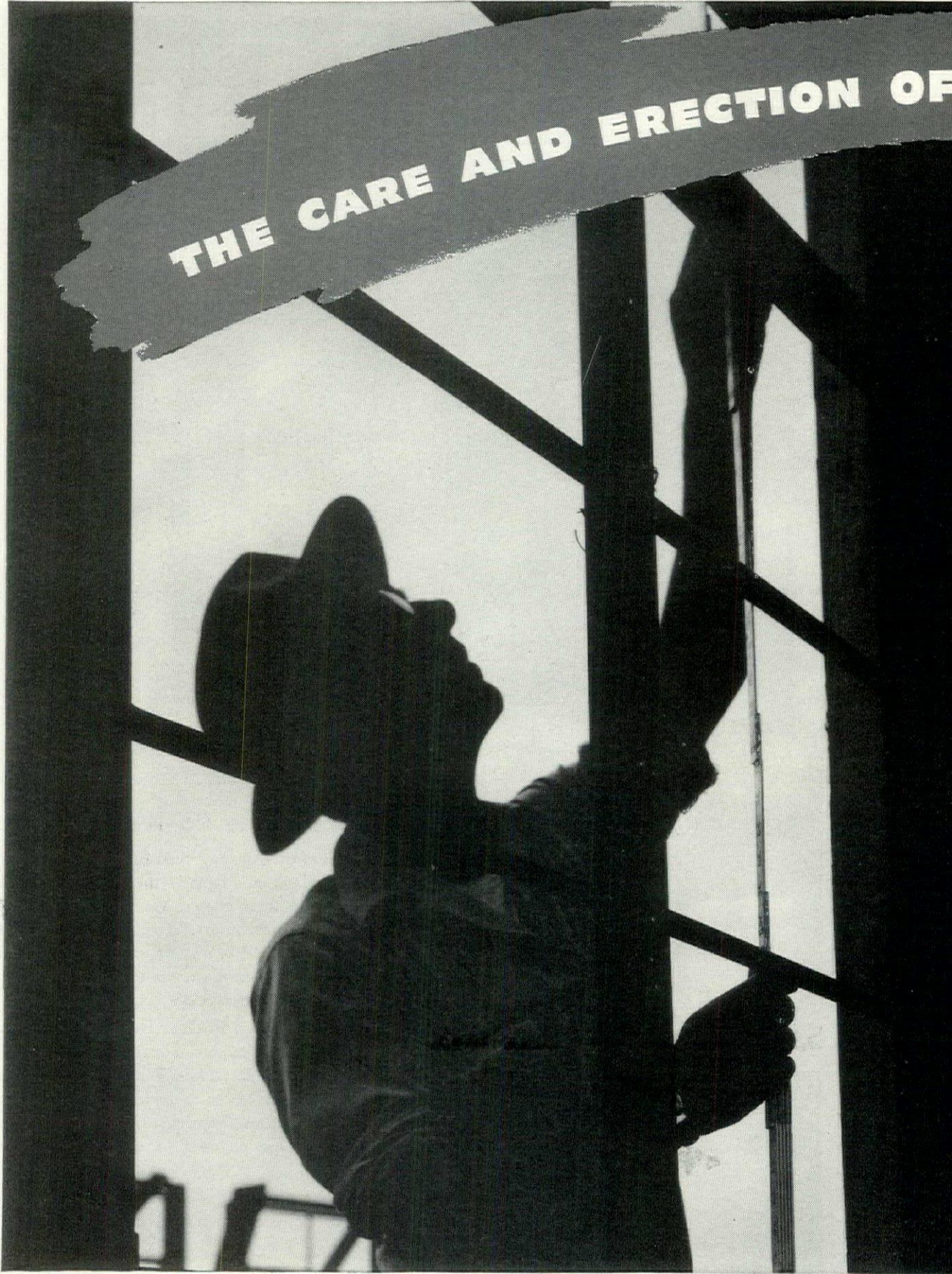

THE CARE AND ERECTION OF

In construction products **CECO ENGINEERING**

CECO Steel Casements

Ceco offers an exclusive service to the building industry—complete detailed data on the care and erection of steel casements. Gone are the days of guesswork, for Ceco provides a manual with all the know-how needed. A few examples are shown here—preparation of opening—how window is inserted—clearance needed at the sill—storage practices. Easy-to-follow instructions will help you cut costs, eliminate damage to windows, avoid loss of time. For complete information, write for Ceco's free Manual today. If you live in one of the western states, ask for special Pacific Coast Edition.

CECO STEEL PRODUCTS CORPORATION

General Offices: 5605 West 26th Street, Chicago 50, Illinois

Offices, warehouses and fabricating plants in principal cities

Other typical products—Steel Basement Windows, Combination Storm and Screen Units, Metal Lath

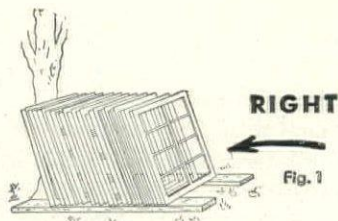

WRONG



HOW TO STORE

Steel residence casements should never be laid flat on top of the other. Always place them vertically, using two parallel planks as a base and lean one unit against the other (Fig. 1).

Do not pile any other materials on top of the casements (Fig. 2) and do not permit other building tradesmen to use them as ladders or as supports for scaffolding. Store the hardware and other fittings in a dry place. When shipped, all ventilators are held shut. Keep the ventilators securely in place until erection.

HOW TO ERECT



Rough openings should be plumbed and squared during construction and must be $\frac{1}{8}$ " wider and $\frac{1}{4}$ " higher than the overall dimensions of the casement frames. This permits installation without distortion.

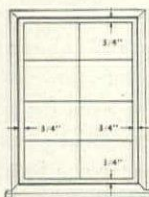

After the casement is erected, when installing inside trim, allow $\frac{3}{8}$ " clearance around the casement on the interior so screens and storm windows may be installed.

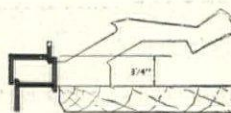

The $\frac{3}{8}$ " clearance is needed at the sill to provide room for the underscreen operator. To get this clearance, in applying the inside trim, bring the finished stool up flush against the bottom edge of the stool gauge on the casement. Then, when the underscreen operator is installed, it will give the appearance of resting on the stool.

ONE OF MANY TYPICAL INSTALLATIONS

Frame Construction with Wood Strip

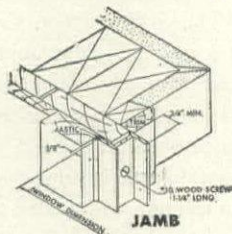
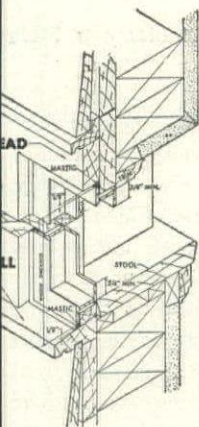

makes the big difference



FREE for you!

CECO STEEL PRODUCTS CORPORATION
5605 W. 26th St., CHICAGO 50, ILL.
 Please send FREE Manual No. 1014 on how to install and store metal casements.

Name _____
 Address _____ State _____
 City _____

Partial List of Ceco Products

- METAL RESIDENCE CASEMENTS • INDUSTRIAL WINDOWS AND DOORS • METAL FRAME SCREENS • ALUMINUM FRAME STORM WINDOWS • ALUMINUM COMBINATION STORM WINDOW AND SCREEN UNITS • METAL LATH AND ACCESSORIES • STEELFORMS • REINFORCING BARS • STEEL JOISTS AND ROOF DECK • HIGHWAY PRODUCTS CORRUGATED ROOFING AND ACCESSORIES • VENTILATORS



ANDERSEN
Windows *

TWO RIBBONS OF GLASS band the facade of this modern home designed by Wessel, Brunet and Kline, architects. These ribbons are formed by one-light Andersen Casement Window Units in conjunction with fixed sash picture windows on both floors. Located in a climate that sees many a sub-zero day, these **WINDOWALLS** are proof against cold air,

yet provide superb ventilation in the summer... performing simultaneously the functions both of a wall and a window.

Specification data on **ANDERSEN WINDOWALLS** is in Sweet's Architectural and Builders' Catalogs, or will be sent by us upon request. See your local lumber or millwork dealer for further information.

*TRADEMARK OF ANDERSEN CORPORATION

Andersen Corporation BAYPORT • MINNESOTA

Andersen Basement-Utility Wood Window Units are completely pre-fabricated ready for quick installation.

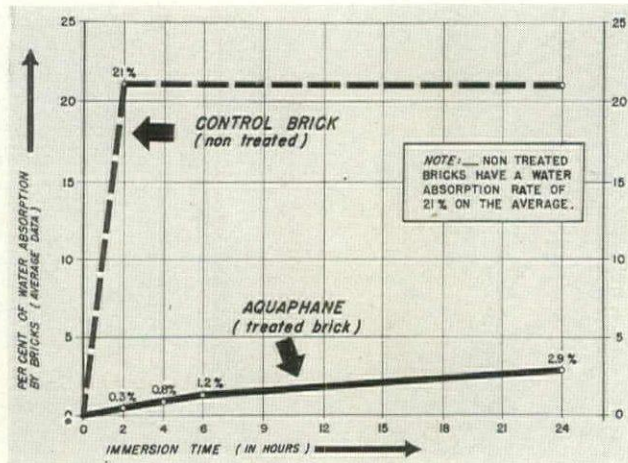

TRANSPARENT COATING for porous masonry walls prevents penetration and absorption of dampness and water

An opaque water emulsion of semi-plastic nature, Aquaphane forms a durable, transparent coating on porous masonry surfaces to prevent the penetration of rain, dampness, snow sleet and water. When brushed on either dry or damp (no wet) surfaces, the milky-white emulsion penetrates the pores of the masonry and dries shortly to provide a smooth, transparent coating. This acts as an efficient barrier against the penetration and absorption of dampness and water, reduce capillary action to a minimum and checks efflorescence. Non-toxic and non-inflammable, an Aquaphane coating will not peel, dust off, blister or bloom. It also will not affect the color or texture of the wall surface. Two coats of the semi-finish are usually recommended for common brick or porous masonry surfaces, or one coat for such low porosity surface as face brick, terra cotta, etc. On porous surfaces one gallon covers between 150 and 225 sq. ft. on the first coat, approximately twice that area on the second.

Manufacturer: International Aquella Products, Inc., Rockefeller Center, New York, N. Y.

CORROSION-RESISTING COATING provides hard, water proof surface for wood tanks, floors, grilles, etc.

According to the manufacturer, Carbo-Kote is an entirely new type of corrosion-resisting coating for treating wood tanks, floors, tables, fume hoods and miscellaneous plant equipment. A thermosetting resin which can be applied with a regular paint brush at ordinary temperatures, it is a transparent brown, gluey substance when mixed which turns green with setting, then black. When applied, Carbo-Kote cannot be separated from the wood base, according to test reports, and is impervious to penetration by moisture or corrosives up to a very high temperature. Its hard, long lasting, waterproof surface resists most acids, alkalis and solvents and is easy to clean. After setting, Carbo-Kote films are also said to flex about 10 to 15 per cent. The new coating, although developed primarily for coating wood, is reported to work equally well on Fibreglas, rubber or carbon. Two coats are suggested for mild corrosive service, up to five coats for severe corrosive conditions.

Manufacturer: Carboline Co., 502 N. Taylor St., St. Louis 8 Mo.

LEAD-FREE SUN-PROOF OUTSIDE HOUSE PAINT retains whiteness, will not darken when used in industrial areas

An entirely lead-free outside house paint, Pittsburgh Plate Glass Co.'s new Sun-Proof paint is reported not only to stay white longer under all normal service conditions, but to remain white even when used in industrial areas where sulphurous gases are present. The new product is made with titanium pigments. These give increased hiding power and improved color to the formulation and, in addition, eliminate the disadvantages found in lead pigments. Exceptionally suitable for use in industrial areas, its manufacturers say the new paint will not darken, as will paints containing lead, which turn from white to varying densities of gray to black depending upon the amount of sulphurous gas encountered. In non-industrial areas, it also offers advantages in providing an initially whiter film which remains whiter longer under normal service conditions. Excellent brushability, fast drying, smooth finish, high hiding power, superior color and durability are

(Continued on page 120)

A Sure Bet...

the new



Popularity votes are being cast nationally for the new Sargent DuaLock, a superbly finished, key-in-the-knob lock. Sargent mass production and economies make possible a quality lock you can sell in the low price field. It is applicable to either metal or wooden doors. Just two holes bored with a standard bit are all that are needed for complete and foolproof installation. No support required with metal doors.

(The DuaLock is fully reversible—one lock for left or right hand regular or reverse bevel without adjustment.) It's just the lock you've long been looking for. See this new DuaLock and other new Sargent products at Booths 50-51, National Hardware Show, Grand Central Palace, New York, October 12-16.

SARGENT & COMPANY

New Haven, Conn.

New York

Chicago

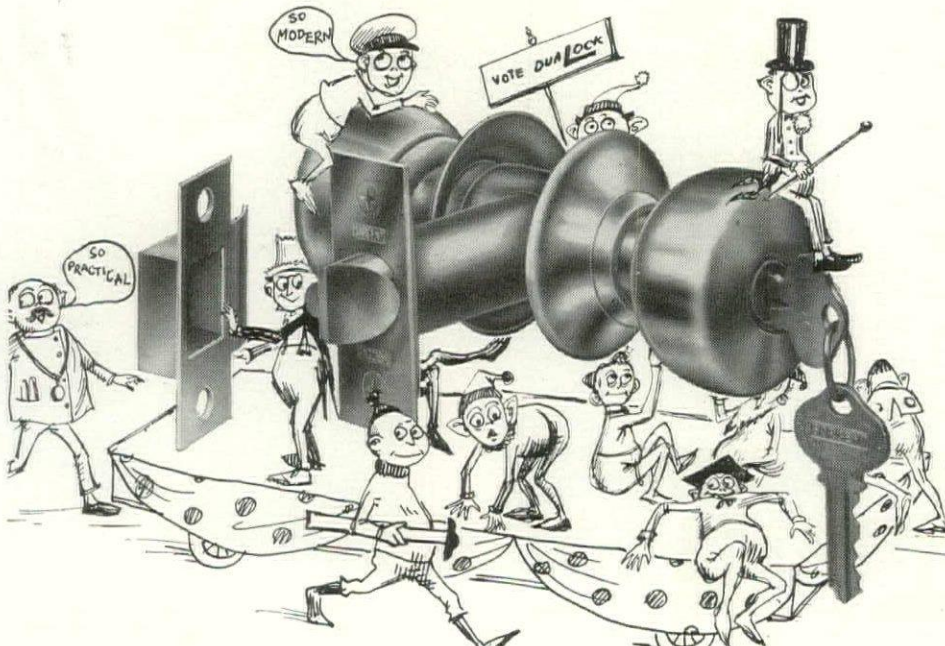

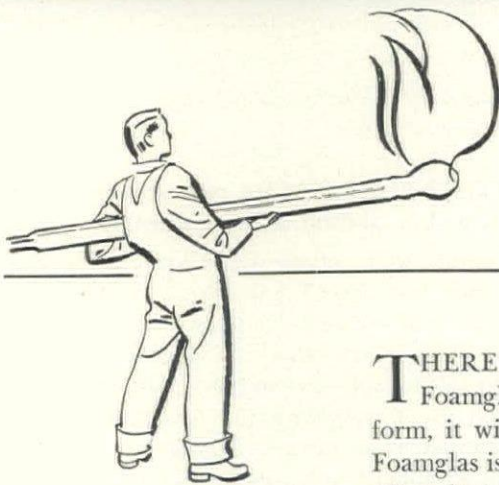
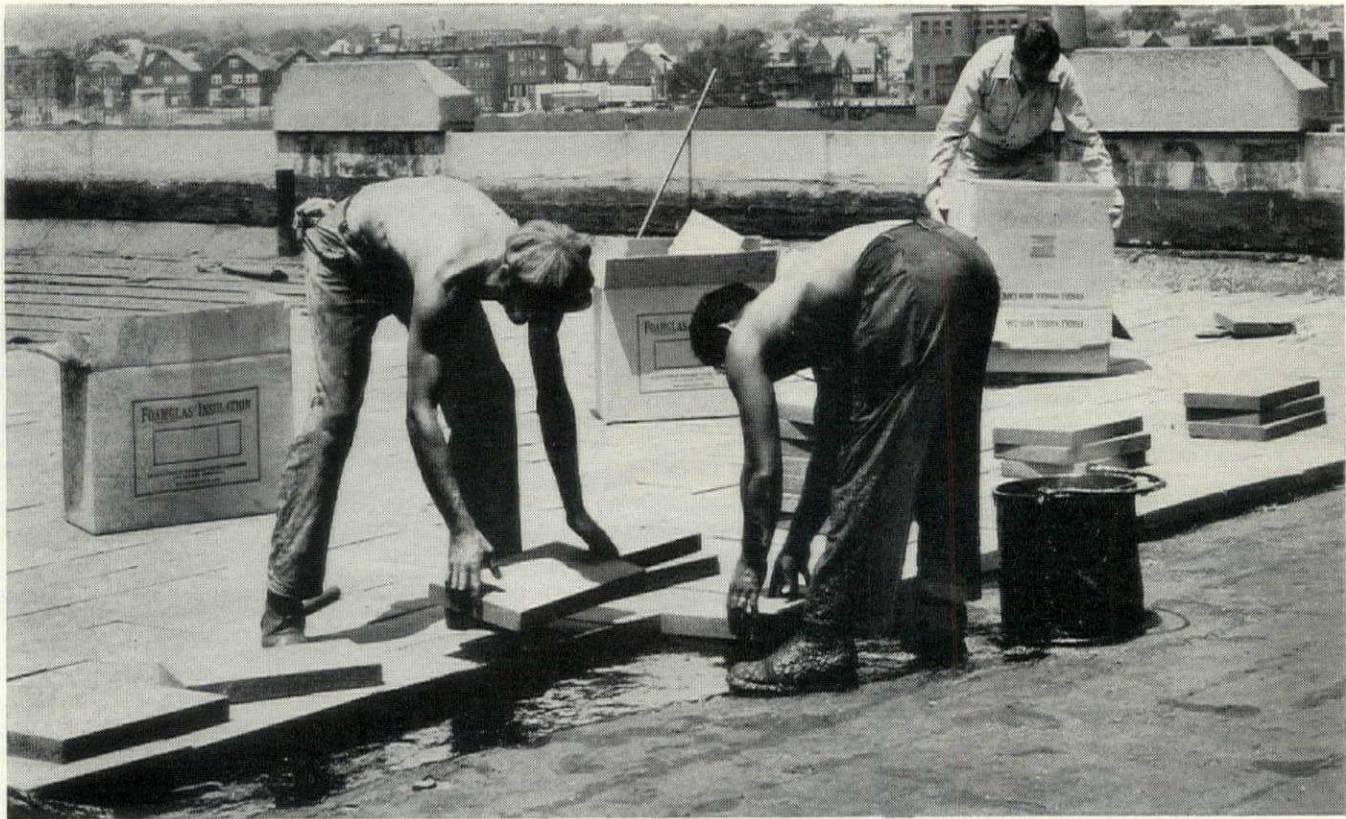

It's Fireproof!

That is one of the main reasons why PC Foamglas is the permanent insulation

THERE is no food for the flames in PC Foamglas. Being true glass in cellular form, it will not burn. That is why PC Foamglas is a positive fire retardant, even when installed over inflammable materials.

On the toughest insulating jobs PC Foamglas is helping to maintain desired temperatures, to minimize condensation under roofs, in walls and floors of all sorts of buildings. It is a vapor stop, it withstands humidity, resists fumes and acid atmospheres. PC Foamglas is waterproof and verminproof.

When installed according to our specifications for recommended applications, PC Foamglas retains its original insulating efficiency *permanently*. Many typical uses are described and illustrated in our current booklets. Check the coupon and send it in today. We shall be glad to forward free copies of the booklets you select. Pittsburgh Corning Corporation also makes PC Glass Blocks.

When you insulate with FOAMGLAS... you insulate for good



FOAMGLAS INSULATION

FOR ADDITIONAL INFORMATION SEE OUR INSERTS IN SWEET'S CATALOGS

AIR SEALED IN GLASS CELLS

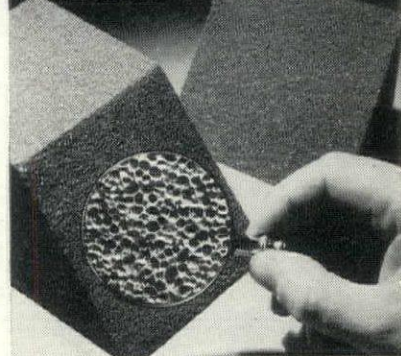

THE MAGNIFIED CROSS SECTION of PC Foamglas shows its cellular structure... glass bubbles solidified into big, strong, rigid blocks. In the millions of cells of glass-enclosed air lies the secret of its insulating value.

Pittsburgh Corning Corporation
Room 503-8, 632 Duquesne Way
Pittsburgh 22, Pa.

Please send me without obligation,
your **FREE** booklets on the use of PC
Foamglas Insulation for:

Roofs..... Walls..... Floors.....

Name.....

Address.....

City..... State.....

other outstanding features. Sun-Proof Titanic Outside White Paint, although designed primarily for use on wood surfaces, is said to be equally effective on brick or masonry. It is supplied in white and colors and is recommended for use in combination with Sun-Proof Exterior Primer to provide what the manufacturer describes as the highest quality two coat paint system available.

Manufacturer: Pittsburgh Plate Glass Co., 632 Duquesne Way, Pittsburgh, Pa.

ONE-COAT HOUSE PAINT with high hiding power dries fast to high gloss, saves time and material.

Devoe One-Coat House Paint is a brilliant white finish, designed to cover in one application any previously painted

house. It is not recommended for unprimed new wood. Easy to apply and drying within six to eight hours after application, One-Coat is said to resist such ordinary paint failures as peeling, blistering, cracking and scaling. These latter features are due to the paint's titanium pigments, known for their resistance to paint failure. The quality of One-Coat is due to a leadless pigment containing 67.5 per cent titanium calcium pigment, 24 per cent zinc oxide and 8.5 per cent titanium dioxide. The vehicle is 75.5 per cent processed vegetable oils with the remainder made up of thinners and driers. The new paint has passed the usual accelerated laboratory tests and, in addition, has withstood four years exposure on over 1800 houses located over the country. Savings are effected by its use not only in labor cost but in material as well, since One-Coat covers approximately 500 sq. ft. per gal. The new paint is made in white only; tinting is not recommended.

Manufacturer: Devoe & Reynolds Co., Inc., 44th & First Ave., New York 17, N. Y.

RESIN-BASED PLASTIC CALKING seals cracks between tile wall and bathtub.

Tub-Tite is a new resin-based plastic calking for sealing cracks in and around washstands, shower stalls, bathtubs, show cases, etc. Applied directly from the tube in which it comes, it is smoothed into place with a furnished applicator and dries within an hour to form a white glossy surface. Tub-Tite remains flexible after application, expanding and contracting with the joint it seals, is unaffected by soap cleanser, oil, grease, acid or water.

Manufacturer: The American Fluresit Co., 635 Rockdale Ave., Cincinnati 29, Ohio.

FLEXIBLE PLASTIC STRIP seals cracks between wall and bathtub to prevent moisture damage.

A pliable white plastic covered strip which can be easily cemented into place, Tub-Kove seals cracks between the bathtub and wall against the entry of steam and water. The flexible strip material follows the contours of the cracks and is easily applied with a waterproof, plastic-base adhesive which adheres firmly to plaster, tile, porcelain, wood or any other type of bathroom surface. Packaged in 15 ft. lengths, Tub-Kove is supplied with adhesive, applicator and instructions.

Manufacturer: Keller Products, Inc., 1880 Roxbury Road, East Cleveland, Ohio.

STAINLESS STEEL VENTILATING WINDOW for use with glass block panels is strong, demands no maintenance.

The new Everlasting Stainless Steel Ventilating Window is reported by its manufacturer to be as long-lasting and maintenance-free as the glass block panels in which it is designed to

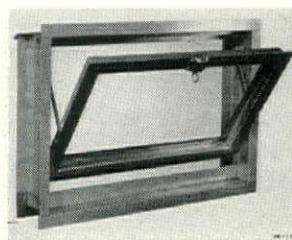

be set. In addition, its cost, which is initially higher than either ordinary steel or aluminum windows, is reported to be lower in the long run due to the fact that no replacements, finishing or maintenance are necessary. The stainless steel construction provides ample strength for load support plus 100 per cent double weathering. The sash is of tubular design for strength and rigidity. Available in almost any required size, the new window can be

(Continued on page 124)



You CAN afford tile!

When you can have all the smartness and practicality of tile, plus additional advantages, *at a substantial saving*—why pay more?

Vikon Metal Tiles are individual tiles made of steel or aluminum, with a durable baked-on face of synthetic enamel. They come in a choice of 27 fade-resistant decorator colors and stainless steel. They are simple to apply over any fairly smooth surface,

and so light in weight that walls need no additional reinforcing.

Vikon Metal Tiles are ideal for walls and ceiling of bath, shower, kitchen, utility and game rooms, halls, laundry and so on. They will not chip, crack or craze... are highly resistant to heat and all ordinary household chemicals. They are fire-resistant, waterproof, and a seal against insects. Write today for complete information.

See our catalog in Sweet's Files



VIKON TILE CORPORATION, WASHINGTON, N. J.

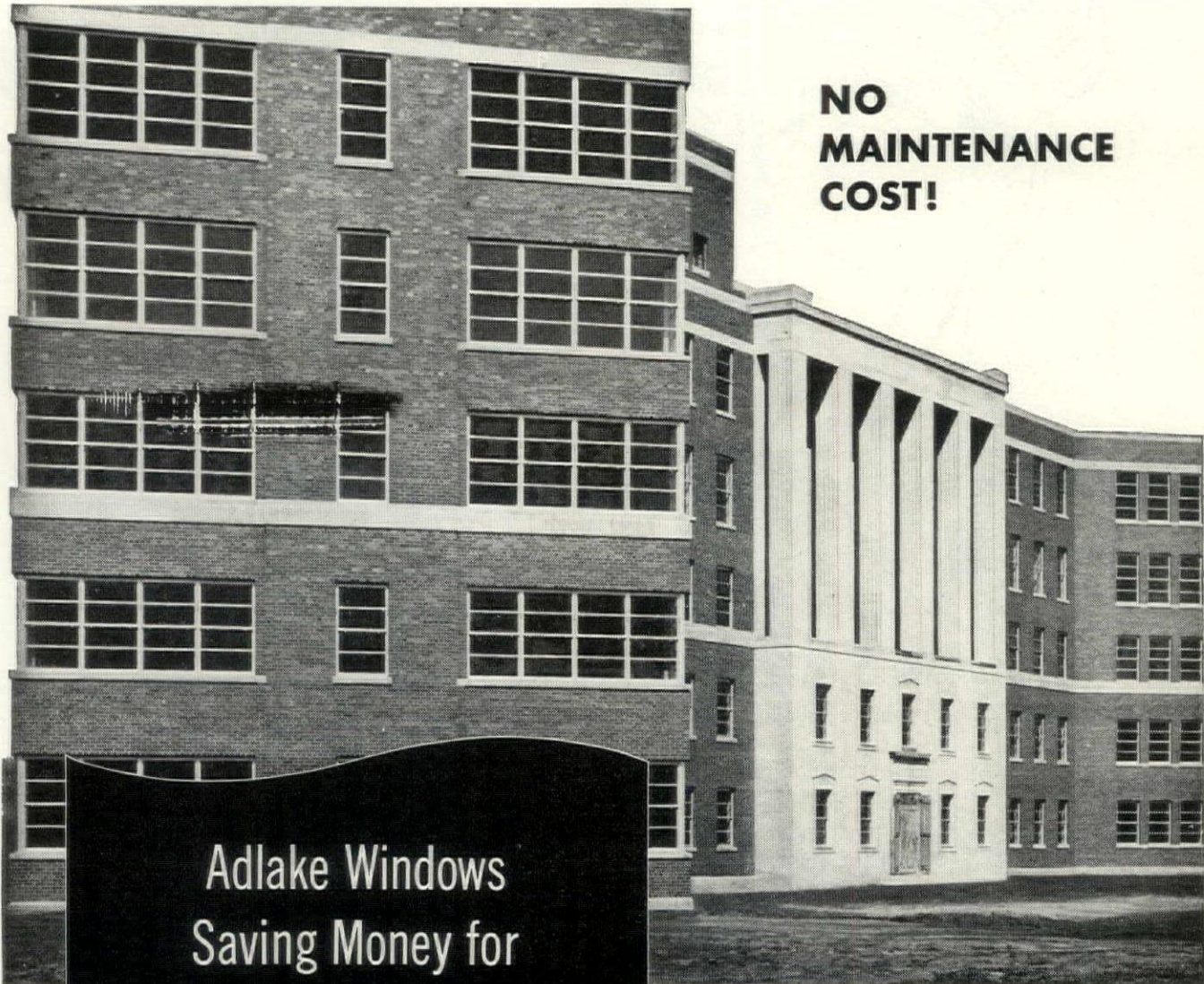

**NO
MAINTENANCE
COST!**

**Adlake Windows
Saving Money for
Helen Rivas Clinic**

The 506 Adlake Aluminum Windows (Series 600) in the newly-built Helen Rivas Clinic*, Rochester, N. Y., will save the hospital a considerable sum, over a period of years, through *eliminating* maintenance costs. The windows will ultimately *pay for themselves* through this economy. Adlake windows require no painting, no maintenance other than routine washing! And they *last as long as the building*.

ONLY ADLAKE WINDOWS have the combination of woven-pile weather stripping and patented serrated guides that assures minimum air infiltration and absolute finger-tip control.

Adlake Windows never warp, rot, rattle, stick or swell. They look lovely and operate smoothly for the life of the building.

INFORM YOUR CLIENTS about the wiping out of maintenance costs and the long, worry-free service they can expect from Adlake Aluminum Windows. For complete data, drop us a post card today at 1101 North Michigan Avenue, Elkhart, Indiana. No obligation, of course.

**Architects: Kaelber & Waasdorp;
Contractor: A. W. Hopeman & Sons*

Adlake Aluminum Windows

have these "plus" features:

- Minimum Air Infiltration • Finger-tip Control
- No Warp, Rot, Rattle, Stick—No Painting or Maintenance • Ease of Installation

**THE
Adams & Westlake
COMPANY**

Established 1857 • ELKHART, INDIANA • New York • Chicago



Furnishers of Windows
to the Transportation Industry
for over 30 years

All Adlake double-hung windows carry this seal



Meet

Marty the Mason



*a hard working guy
you ought to know*



"Then maybe the men who build the big hospitals and schools and all the homes and stores are pretty important guys, too!"

Marty is a regular fellow doing a good job for everyone in the building industry . . . especially in apprentice training.

These excerpts from his everyday life will give you a slight idea of what he has to say about problems with which all of you are concerned.

90,000 brickmasons and plasterers regularly follow the "Marty the Mason" page in their union magazine. They find a good chuckle and a lot of down to earth logic in what Marty says about the building business . . . even if he doesn't say it exactly like a Daniel Webster

Marty shows his buddies how they can strengthen the future of their trade by training more men to carry out your plans . . . better, faster, and more economically . . . with brick and tile.

Marty's work is part of a major effort by Structural Clay Products Institute. This effort includes apprentice training, promotion of modular coordination, research and the brick engineered housing programs. In every case SCPI's final goal is the same . . . better and more efficient building.

To help you with your building problems two new basic handbooks, "Brick Engineering" and "Tile Engineering," are available at \$2.50 each postpaid. Write Desk AF 10, Structural Clay Products Institute, 1756 K Street, N. W., Washington 6, D. C.



"Suppose a contractor needs ten men to do a job in brick and we can only give him five?"



"Supply-demand, demand-supply," she says to me, "I'm talking about the high price of butter and eggs."



"I tell her everyone I work with is on a team and she says, 'Marty, you've been sitting in the sun too long'."



"Well, son, Benjamin Franklin was a very great man. Diplomat, printer, philosopher, scientist. Old Ben was a brickmason like your dad too . . ."



"It's plain enough to me," I tell her, "that a ball game is no place for a woman in the first place."

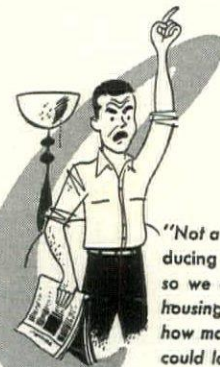

"Not a man-of-action, eh? I'm producing every minute I'm on a wall so we can lick high costs and the housing shortage. I'd like to see how many courses your Mr. Tyrone could lay in a day."



New building addition to Country Life Press, Garden City, N. Y., containing 110,000 sq ft of floor space with electrical raceways always quickly and conveniently available.

Country Life
PLANNED
FOR A LIFETIME



Q-Floor in place on first floor. Notice large number of cells—everyone available for wiring.

CONSTRUCTION DATA

Architect:.....H. T. Lindeberg
 General Contractor:..George A. Fuller Company
 Consulting Engineer:.....Clyde R. Place
 Electrical Contractor:..Naumer Electric Company

Country Life Press, Garden City, New York, needed a wiring system that would permit fast relocation of electric equipment—a wiring system that would be readily adaptable to changes in circuits and outlets with a minimum of expense. When they planned this new 110,000 sq-ft plant addition, they could determine initially needed electrical and signal outlets. However, it was practically impossible to estimate future demands. To meet these, Country Life included Robertson Q-Floors with General Electric Q-Floor Wiring, to give them the electrical flexibility they needed.

Buildings equipped with General Electric Q-Floor Wiring enjoy a decided advantage. At any time during the life of the building, circuits can be removed or new outlets can be installed on the floor surface where they are needed, when they are needed, in a few minutes. Changes can be made easily and quickly, without digging trenches, and without interrupting occupants' activities.

By means of simple fittings, the entire Q-Floor becomes part of the electrical and signal distribution system. Since the cells are on 6-inch centers, outlets can be installed every six inches. To add a new outlet, it is necessary only to tap through the floor into the Q-Floor cell and install the floor outlet.

Want more information on General Electric Q-Floor Wiring? Write on your letterhead for a free copy of the *Q-Floor Wiring Data Manual*—address Section C7-104, General Electric Company, Bridgeport 2, Connecticut.

Q-Floor is manufactured only by the H. H. Robertson Company, Pittsburgh, Pa. Samples can be seen at any General Electric Construction Materials office or Robertson District Office.

Q-Floor Wiring
 FOR ELECTRICAL FLEXIBILITY

GENERAL  ELECTRIC

BUILDING REPORTER

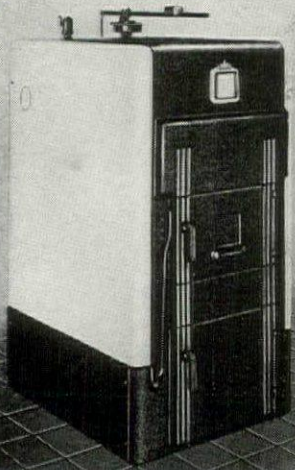

used in industrial, commercial or residential construction and, if desired, can be equipped with stainless steel-framed plastic screens.

Manufacturer: Modern Electric Laboratory, 6131 South Wentworth Ave., Chicago, Ill.

CONVERTIBLE BOILERS for steam or hot water heating of homes and buildings feature increased heating surface.

National Radiator Co.'s new line of heat extractor boilers includes four models, three of which can be hand, oil, stoker or gas fired. The fourth—the smallest model—does not take stoker firing. All units can be converted after installation. Also in the company's new line are two heating units, which are combinations of the company's boilers, oil burners, com-

ustion chambers, and automatic controls. These are available in ten sizes, ranging in net rating from 230 to 880 sq. ft. of steam radiation, 370 to 1,410 sq. ft. of hot water radiation and are designed to meet the heating and domestic hot water requirements of very small to fairly large residential installations. The two larger boilers in the series are geared to business and institutional requirements. The basis of the heat extractor boiler principle is the increased heating surface presented by sets of ridges which stud the heating surface within flue passes and on firebox crowns to capture and hold heat, cutting down stack losses.

Manufacturer: The National Radiator Co., Johnstown, Pa.

OIL-FIRED FURNACE BURNER UNITS offer efficient performance, compactness and trim appearance.

The three new furnace burner units in the Williams Oil-O-Matic line, with capacities ranging from 70,000 to 150,000 BTUs at the bonnet, are designed to meet heating requirements of small, medium and large homes. The smallest unit, Model 70, is a completely packaged unit measuring 58 in. long, 22 in. wide and 45 in. high. Supplied completely assembled and wired to reduce on-the-job installation costs, it can be set in most utility rooms. A feature of Model 70 is its high temperature stainless steel combustion chamber which reaches peak operating temperature in only a few seconds to assure quick, clean, complete, efficient combustion. Another feature of this model is the heat exchanger which makes use of a newly developed heat intensifier baffle to increase the effectiveness of the area of heat transfer. The intermedi-

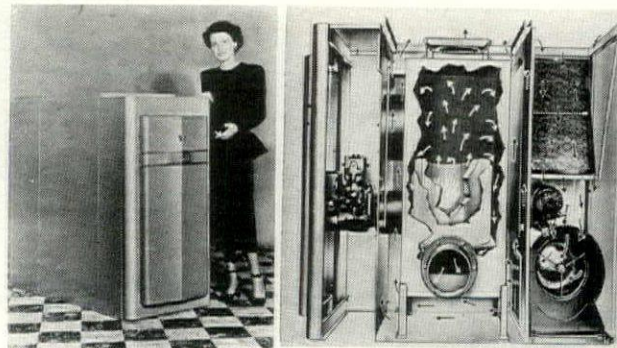

Model 10-A (illustrated) with a capacity of 100,000 BTUs and Model 15-A, the largest unit, are reported to not only supply exceptionally efficient fuel saving automatic heat, but also to provide healthful automatic humidification and air filtering. Both units incorporate the Oil-O-Matic Vertical Counterflow heat exchanger which has proved, according to the manufacturer, unusually efficient and economical in units of these capacities. Both also feature new styling by George Walker; Model 10-A is for small and medium size homes, Model 15-A is for larger size homes.

Manufacturer: Williams Oil-O-Matic Div., Eureka Williams Corp., Bloomington, Ill.

DUAL-FIRED STEAM GENERATOR is easily converted to avoid fuel shortage shutdowns.

The Dutton Economist Dual-Fired Steam Generator is designed to eliminate costly shutdowns due to fuel shortage by providing overnight conversion to an alternate fuel. An automatic packaged steam generator of the HRT type,

(Continued on page 122)

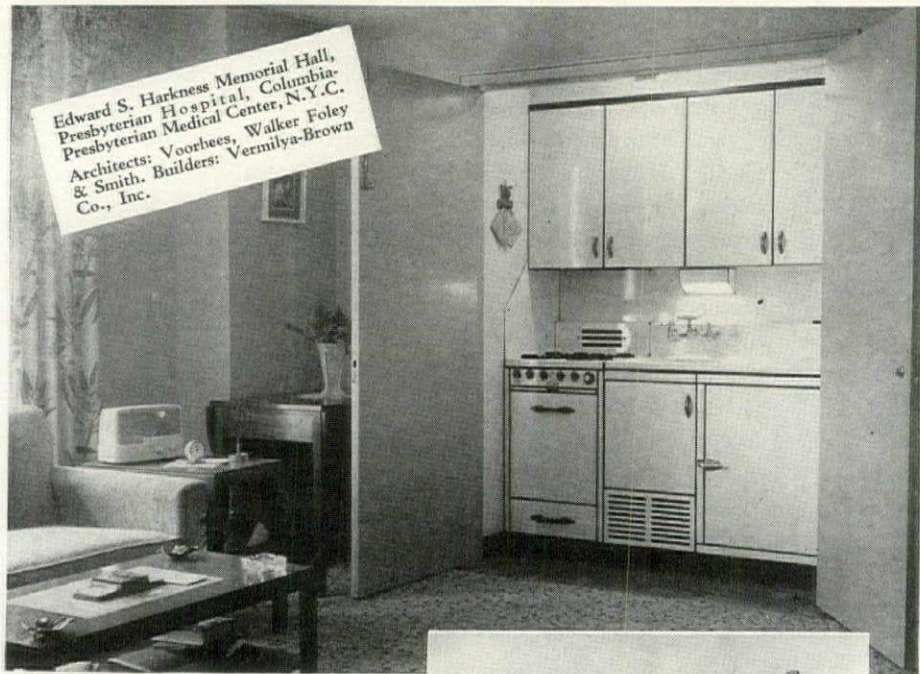

Edward S. Harkness Memorial Hall,
Presbyterian Hospital, Columbia-
Presbyterian Medical Center, N.Y.C.
Architects: Voorhees, Walker Foley
& Smith. Builders: Vermilya-Brown
Co., Inc.

183 Murphy-Cabranette Kitchens

Erected in 1947 as a dwelling-place for hospital personnel, this building is a model of modern apartment design.

Murphy-Cabranette Kitchens give complete kitchen facilities in minimum space. In each compact unit are combined modern range (gas or electric) with heat control and insulated oven, refrigerator with push-button door and stainless steel frozen food compartment, deep-bowl sink and storage space. Sink-and-range top are combined in one piece. All exposed surfaces are of genuine vitreous porcelain, easy to clean and never requiring repainting.

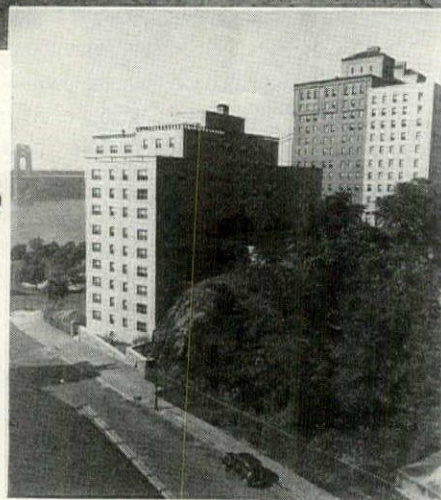

Murphy-Cabranette Kitchens are recommended for buildings which seek to save space, to provide modern convenience with trouble-free operation and negligible maintenance cost.



DWYER PRODUCTS CORPORATION
Dept. F10- MICHIGAN CITY, INDIANA

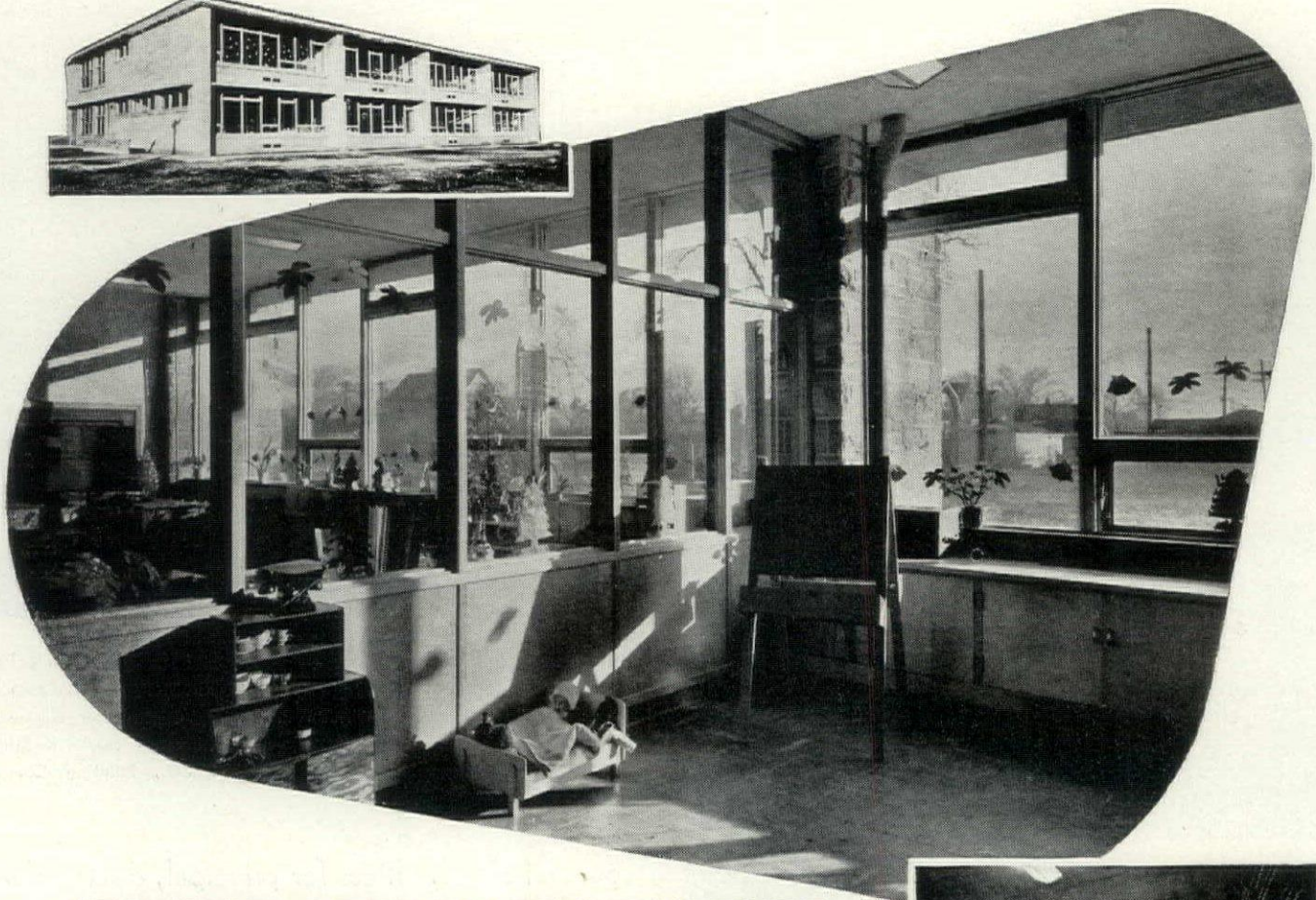

ADD DAYLIGHT-ASSURE COMFORT in the same specification

*Thermopane** enlarges your design opportunity—enables you to provide generous daylight-transmitting areas without making concessions on comfort or heating economy. Thus, *Thermopane* fits neatly into today's pattern of more daylight, more comfort.

The *Thermopane* unit consists of two or more panes of glass, with specially-cleaned, dehydrated air between, sealed around the edges by L·O·F's *Bondermetic* (metal-to-glass) *Seal**. This prevents dirt or moisture from entering the insulating air space.

Thermopane's low coefficient of heat transfer (U value of .58 for double *Thermopane* with 1/2" air space) reduces heat loss through the glass, saves fuel and reduces downdrafts at windows. With

Thermopane there's little chance of condensation forming on the glass under average conditions... making it easier to maintain proper humidity for health and comfort.

The benefits of *Thermopane* are enjoyed the year 'round, for its insulating qualities also help keep rooms cooler in summer... aid efficient operation of air-conditioning equipment.

Thermopane is available for prompt delivery from your L·O·F Distributor in more than 70 standard sizes as well as units of special dimensions. It may be installed in either fixed or opening sash. For complete information, write for our *Thermopane* book and Technical Sheets by Don Graf. * Libbey-Owens-Ford Glass Company, 21108 Nicholas Bldg., Toledo 3, Ohio.

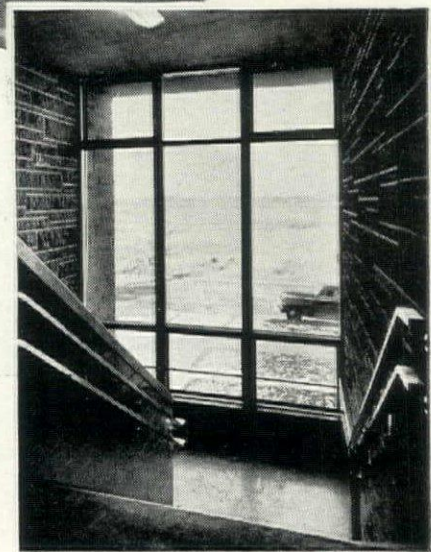

● Glazed throughout with *Thermopane*, Drexel School, Cicero, Illinois, provides ample daylight with more comfort in all classrooms. Because *Thermopane* deadens sound, it is practical for partitions. Stairways daylighted with a generous glass area of *Thermopane* are safer, less drafty. Architects and Engineers: Perkins and Will, Chicago.

IN CANADA, THERMOPANE IS SOLD BY PILKINGTON GLASS, LTD.

*®

Only Libbey-Owens-Ford makes

Thermopane



LIBBEY · OWENS · FORD

a Great Name in **GLASS**

★ Modern Decoration for Modern Schools!

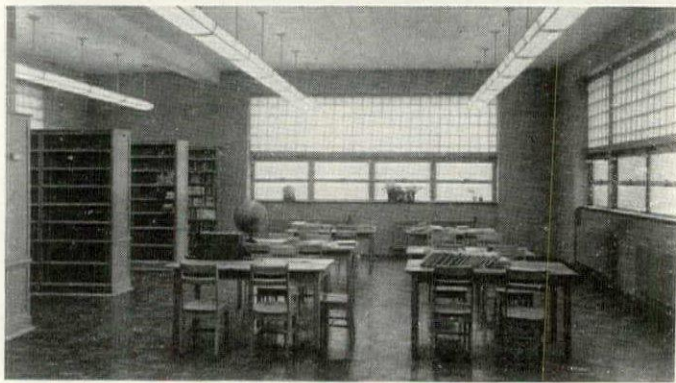
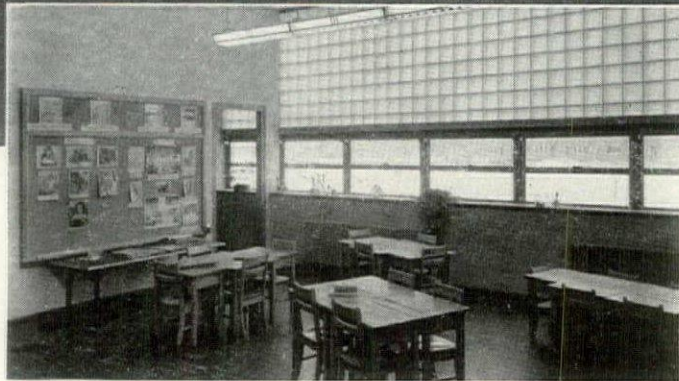
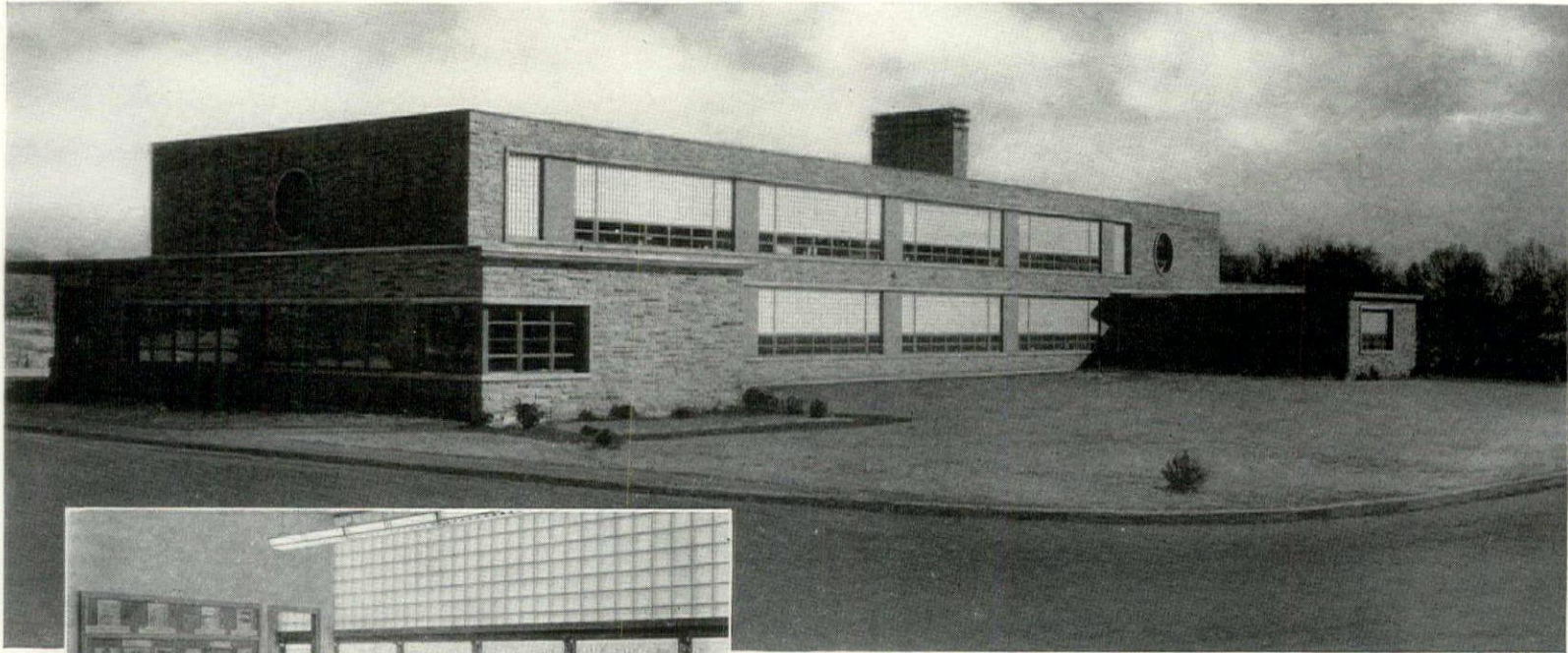

LOCH RAVEN ELEMENTARY SCHOOL, BALTIMORE COUNTY, MARYLAND
 BOARD OF EDUCATION OF BALTIMORE COUNTY — EDWARD G. STAPLETON,
 Associate Superintendent; MORRIS R. BAKER, Construction Engineer, Towson, Md.
 GAUDREAU AND GAUDREAU, Architects, Baltimore • JOHN K. RUFF, INC., General
 Contractor, Baltimore • C. A. SCHMICK CO., Painting Contractor, Baltimore

general office, offices for principal, doctor, dentist, nurse; waiting room and dressing room. There are 16 classrooms, library, faculty room with rest room, cafeteria and a multi-purpose room.

All interior walls are cinder block, laid with rule joints and decorated with the authentic colors of Pratt & Lambert Lyt-all Flowing Flat. Plaster was entirely eliminated. Asphalt tile flooring in classrooms, plastic tile flooring in corridors, cinder block walls, and acoustical tiled ceilings make the building practically sound-proof. Doors and wood trim are oak, finished with Pratt & Lambert "38" Pale Trim Varnish.

Because of its interesting and functional design, this building has been visited by many school authorities.

The Pratt & Lambert Architectural Service Department will aid you in planning authoritative decoration and with maintenance work.

PRATT & LAMBERT-INC., Paint & Varnish Makers
 NEW YORK • BUFFALO • CHICAGO
 FORT ERIE, ONTARIO

OCCUPYING an elevated position on a 30-acre tract, overlooking beautiful home sites, a golf course and rolling countryside, this modern building is the first unit of an elementary and junior high school, and was planned to provide much flexibility for future additions.

The exterior is seam-face ashlar stone. This colorful stone and style of design permit a window treatment of directional glass block and steel sash for natural lighting, supplemented by fluorescent ceiling lighting.

The structure, of reinforced concrete floor and roof slabs, and steel framing, includes an administration suite for

PRATT & LAMBERT PAINT AND VARNISH



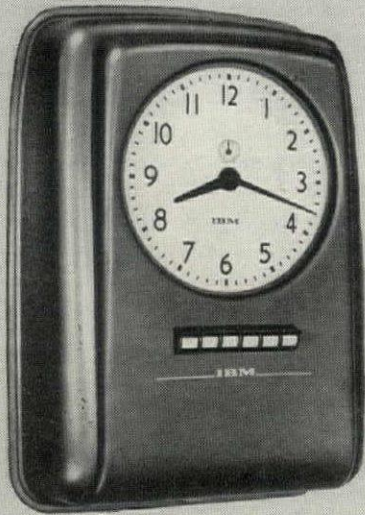

A New **IBM** Electric Time System

- *with electronic self-regulation*
- *installed without special clock wiring*
- *operating from regular AC power supply*

**IBM Master Time
and Program Control,
through Electronics,**



Supervises:



Clocks

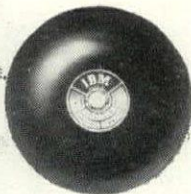

Signals



Time Recorders

A new Electric Time System in which indicating clocks are connected directly to the regular AC current supply and are self-regulated electronically, ALL WITHOUT SPECIAL CLOCK WIRING, has been developed by IBM.

In any building which has 110-volt, 60-cycle, supervised alternating current, IBM synchronous motor indicating clocks can be connected to a regular wall plug or light socket outlet. Once an hour each clock is checked individually and regulated automatically for uniformity with system time.

Another feature of the new system is automatic signaling without special signal wiring. Self-regulating minute impulse recording units—Attendance Time and Job Cost Recorders, Time Stamps—are operated through an adapter unit.

For information on this new, flexible, economical Electric Time System, write to the address below.



TIME RECORDERS AND ELECTRIC TIME SYSTEMS

**Proof Machines • Electric Punched Card Accounting Machines
and Service Bureau Facilities • Electric Typewriters**

International Business Machines Corporation, World Headquarters Building, 590 Madison Avenue, New York 22, N. Y.

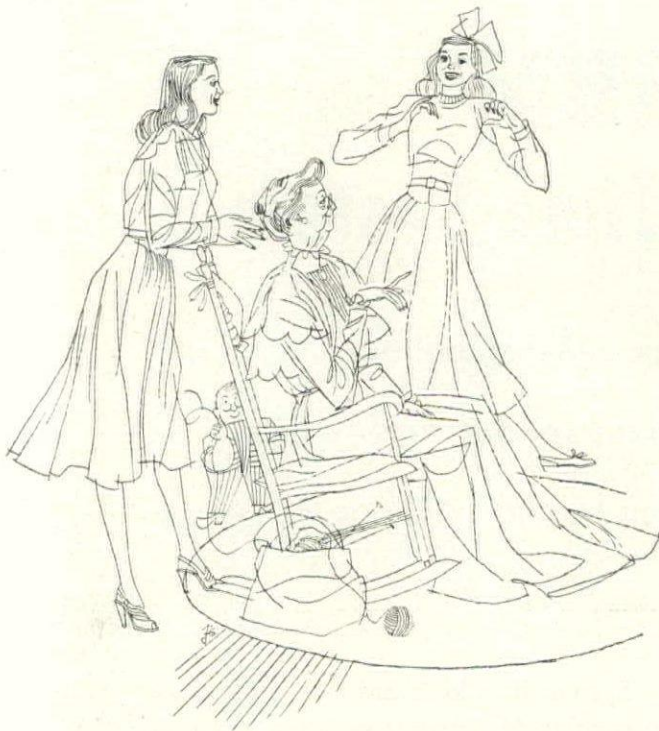

ROOMS WITH *Oak Floors* HAVE STYLE ADAPTABILITY

With most of your clients, oak flooring will always be the first choice for new homes because of its inherent natural beauty, durability and lasting economy.

But, as you know, many people want changes . . . new rugs, drapes, wallpaper, paint and furniture. Here, too, oak is recommended because, with its warmth and charm, oak flooring complements the beauty of these new surroundings whatever their style or color.

For wall-to-wall carpet, oak floors offer a smooth, firm—yet resilient—base which protects carpeting and makes cleaning easier. And when carpeting wears out, or owners tire of it, the permanent beauty of oak is always there.

So, for long-time adaptability, start with oak floors.

ASK FOR ARCHITECTS' DATA BOOK—which gives quick and usable information for specifying, laying, finishing and maintaining oak floors. Available from your local oak flooring dealers or from the National Oak Flooring Manufacturers' Association, 814 Sterick Building, Memphis, Tenn.

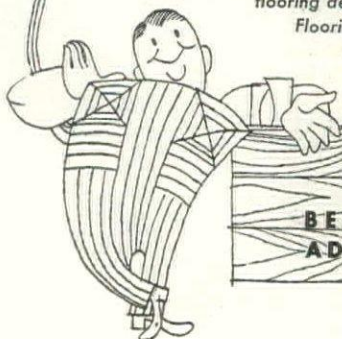
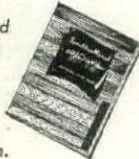

comes with either gas or oil burner and rocking type grates built into a base section for coal firing. When oil or gas fired, these grates are floored over with insulation and fire-brick. If the oil or gas supply becomes acute, however, the floor may be removed to allow coal firing. The changeover requires only a few hours and there is no loss of efficiency when shifting from one type of fuel to another. The new Economist has a full length refractory-lined high fire box in which the heavy gases are consumed before reaching the tubes, and which produces an incandescent firing chamber. The generator, for use with light oil, heavy oil or gas, and for hand or stoker coal firing, is supplied in five sizes. It is shipped completely bricked up and insulated, ready to set down and fire.

Manufacturer: The C. H. Dutton Co., Kalamazoo, Mich.

STEAM-GENERATING UNIT burns light or heavy oil or gas— can be changed over in 10 minutes.

The Powermaster is a new packaged steam-generating unit which burns light or heavy oil or gas and can be converted from one fuel to another in about 10 minutes. Ranging from

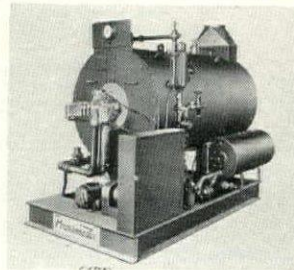

15 to 200 h.p., the boiler system is fully automatic. It is said to burn heavy fuel with the same complete, clean combustion with which it burns light oil or gas, and to feature fully automatic operation of heavy fuel combustion. Other advantages of this new unit

include: modulated control of flame-volume to maintain constant steam pressure as steam demand varies, easily accessible tubes, and a new air-atomizing burner which promotes complete and clean combustion. Safety features include an electronic fire-eye (for oil) and a flame rod (for gas) which automatically shut off the boiler in case of flame failure.

Manufacturer: Orr & Sembower Inc., Reading, Pa.

METER measures air velocity, air temperature, static pressure; aids testing of heating and ventilating equipment.

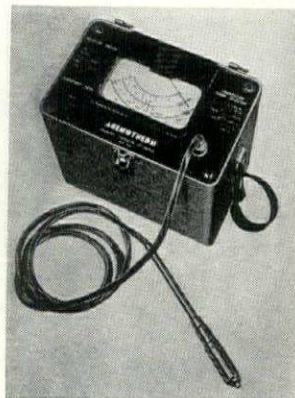

The Anemotherm is a new lightweight, portable, three-way meter which gives air velocity, air temperature and static pressure readings at the turn of a knob. Used to adjust and test heating, ventilating and air conditioning equipment, it measures air velocity from 10 fpm to 5,000 fpm, and provides rapid-response measurement of temperatures from 30° F. to 155° F. Either negative or positive static pressure

may also be read directly in inches of water, from .05 to 10 positive and .05 to 4 negative. The instrument's small probe, which is attached to a long flexible cable, permits easy readings to be made under difficult conditions.

Manufacturer: Anemostat Corp. of America, 10 East 39th St., New York City, N. Y.

(Continued on page 132)

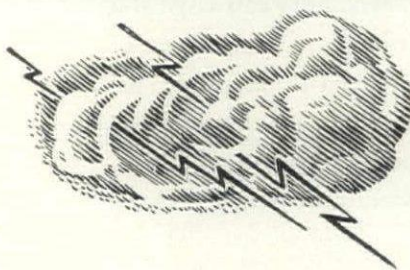

THUNDER IN THE CORRIDORS?

A HOSPITAL corridor can be a booming echo chamber! Ordinary footsteps sound like thunder-claps. It's a trying condition disturbing to both patients and staff. But it can be easily remedied:

You can stifle corridor noise with Gold Bond Acoustimetal. It's designed to insure maximum noise reduction—and to give high light reflection. And it's *Fireproof*

to fit new building code specifications.

Best of all, maintenance is cut to an all time low! Each tile is an access panel, for quick repairs to wiring, piping, and air ducts. The 12" x 24" perforated pans snap into patented T-bars, and these T-bars can be mounted any distance from the ceiling which may be required to provide space for pipes, cables, and ducts. They are as adaptable to remodeling as to new building.

What's more, Acoustimetal can be washed repeatedly and even repainted without loss of sound absorption. Write now for the new Acoustimetal folder for complete details. Fully described in Sweet's, too.

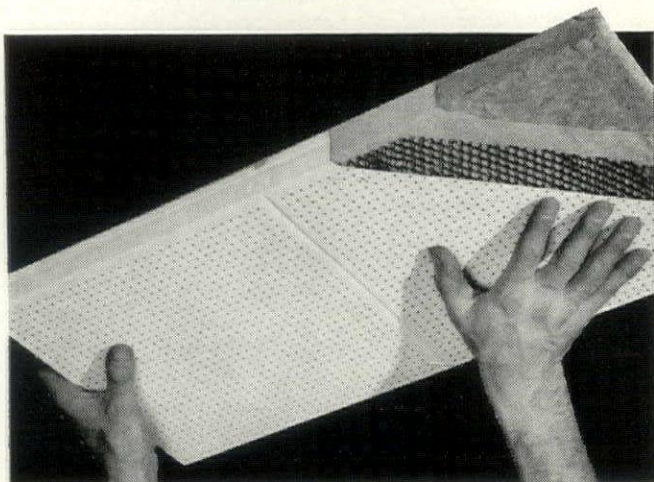

Gold Bond Acoustimetal—The Fireproof, washable acoustical tile for exacting sound control.

You'll build or
remodel better with

Gold Bond

NATIONAL GYPSUM COMPANY • BUFFALO 2, N. Y.

Over 150 Gold Bond Products including gypsum lath, plaster, lime, wallboards, gypsum sheathing, rock wool insulation, metal lath products, and partition systems, wall paint and acoustical materials.

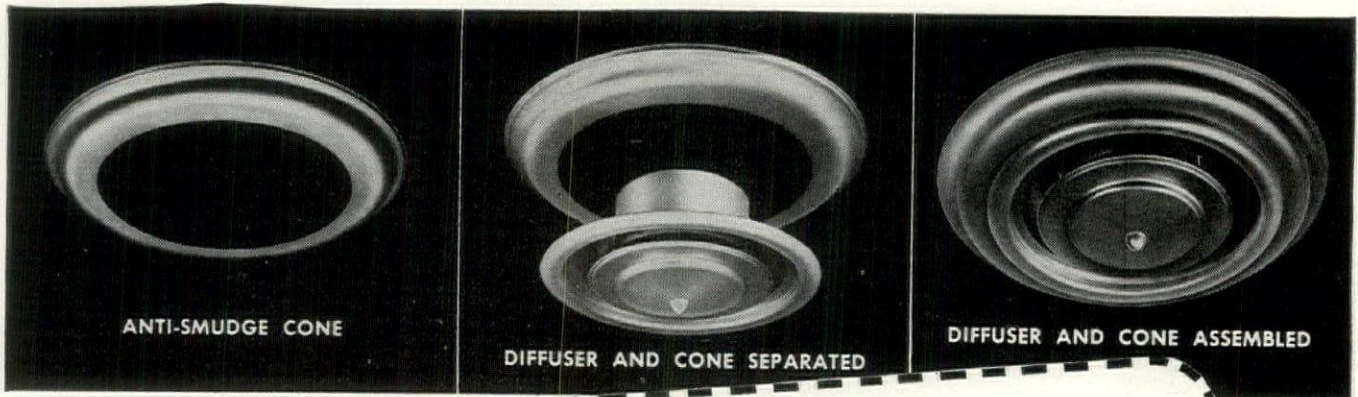

Announcing Kno-Draft Ceiling Smudge Control

Now you can control tough smudging problems. When exceptionally sooty, smoky or dusty air conditions are expected, or where rough textured, dirt-catching ceilings are employed, Kno-Draft Anti-Smudge Cones give the utmost in protection—and increase the attractiveness of the diffuser besides.

How it works

Under normal conditions, all Kno-Draft diffusers can be adjusted so that their specially designed deep shoulder rims will deflect the discharge air away from the ceilings and prevent smudging. However, under the abnormal conditions mentioned above, the use of Kno-Draft anti-smudge cones is recommended. They furnish the additional control which will enable you to provide the precise minimum separation of the discharge air from the ceiling that you need to inhibit smudging and, at the same time, maintain the radial air diffusion pattern you need to eliminate drafts.

What we can do to help

W. B. Connor Engineering Corp. maintains a research laboratory with a staff of trained specialists and district representatives in leading cities. Their services are at the disposal of con-

sulting engineers, architects, air conditioning dealers, and plant engineers. They can assist you in getting the best possible performance out of your air conditioning system by creating custom-made air patterns which thoroughly mix room and supply air, eliminate drafts, and maintain uniform temperature throughout an area.

FREE HELPFUL LITERATURE

- BULLETIN K-22—Contains complete details on the new and exclusive Kno-Draft Anti-Smudge Cone.
- NEW HANDBOOK ON AIR DIFFUSION — Contains all the engineering data necessary on air diffusion in general and Kno-Draft Adjustable Diffusers in particular to enable you to create "custom-made" air patterns and eliminate drafts.

W. B. Connor Engineering Corp.
 Dept. T-106, 112 East 32nd Street
 New York 16, New York

Please send me the free literature I have checked above.

Name.....

Company.....

Street.....

City..... Zone..... State.....

W. B. CONNOR ENGINEERING CORP.

Air Diffusion • Air Purification • Air Recovery

112 East 32nd Street  New York 16, N.Y.

IN CANADA: Douglas Engineering Co., Ltd., 190 Murray Street, Montreal 3, P. Q.

Get Guaranteed Dimensional Stability

with The New Weldwood Flush Veneer Door

New Mineral Core and Precision Manufacture give Weldwood Flush Veneer Doors Extraordinary Dimensional Stability

These beautiful new wood-faced doors always measure up. They won't swell in summer . . . won't shrink in winter.

The new mineral core of the Weldwood Flush Veneer Door gives it such a degree of dimensional stability that we back it with the most sweeping guarantee ever given by any manufacturer.

Weldwood Doors are guaranteed against warpage or binding in opening due to any dimensional changes in the door.

Here indeed is a superior door. Just go over this checklist of advantages:

- 1 **PERMANENT BONDING** of veneers to core and banding with TEGO Film Waterproof Glue by hot plate process.
- 2 **VERMIN AND DECAY PROOF** mineral core resists fungus, decay and termites for the life of the structure.
- 3 **INSULATING PROPERTIES** are superior to double glazing, such as opening protected by storm door . . . when door is installed in an exterior opening with weather stripping.
- 4 **EXCELLENT VAPOR BARRIER.** TEGO Film Phenolic Glue bond provides a completely effective moisture barrier.
- 5 **INCOMBUSTIBLE MINERAL CORE.** Core has a fibrous binder with a nominal density of 20 lbs. per cubic foot. This material has a sturdiness which assures proper performance of door under the most severe conditions.

We'll be glad to rush you full specifications on this new door. Write or contact our nearest branch.

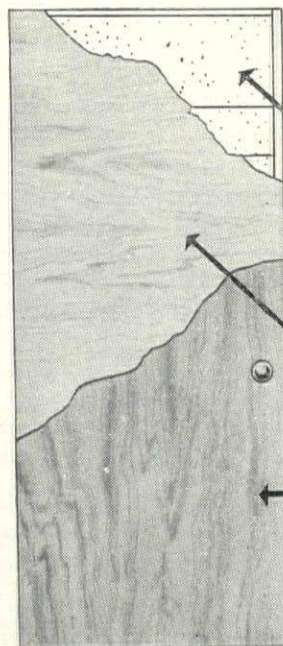
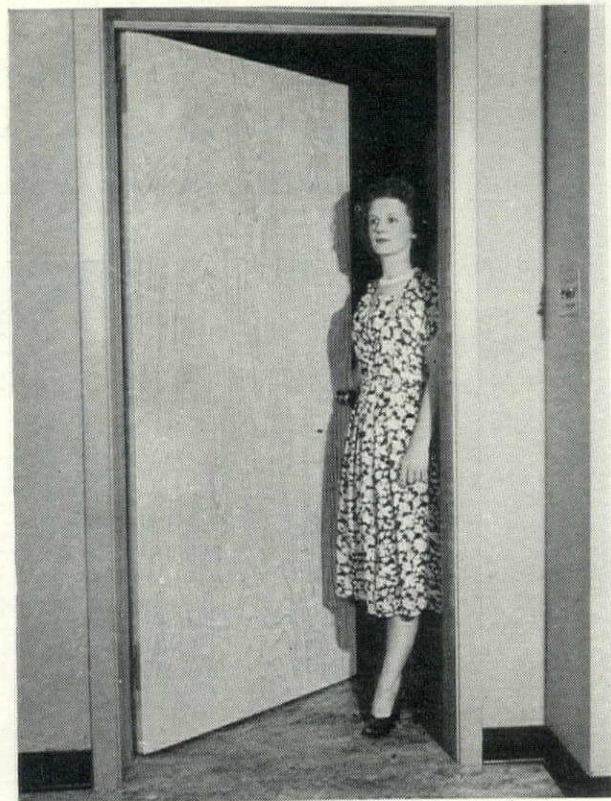

EDGE BANDS are thoroughly kiln dried hardwood, built up of two pieces of $\frac{3}{4}$ " stock, securely glued together to provide greater dimensional stability.

MINERAL CORE. Each core is made of three or more pieces, securely bonded together by high frequency process, thus offering a solid piece of homogeneous character. Moisture content not in excess of 4½%. Sized with highly waterproof solution, offering a perfect base for laminating cross bands and faces.

CROSS BANDING of 1/16" veneer is bonded to core with TEGO Film Waterproof Glue.

FACE VENEER. At present, handsome Birch veneer forms the hardwood faces. Wide variety of other decorative woods available on special order.

UNITED STATES PLYWOOD CORPORATION

55 West 44th Street, New York 18, N. Y.

Distributing units in Baltimore, Boston, Brooklyn, Chicago, Cincinnati, Cleveland, Detroit, Fresno, High Point, Los Angeles, Milwaukee, Newark, New York, Oakland, Philadelphia, Pittsburgh, Portland, Ore.; Rochester, San Francisco, Seattle. Also U. S.-Mengel Plywoods, Inc., distributing units in Atlanta, Dallas, Houston, Jacksonville, Louisville, New Orleans, St. Louis, Tampa.
In Canada: United States Plywood of Canada, Limited, Toronto.

We Invite You to Accept this *CHALLENGE!*

We want 10,000 Skeptics to smear, splatter, write or even walk on Stainproof Varlar and try to mutilate the first-day beauty of this durable, washable wall covering.

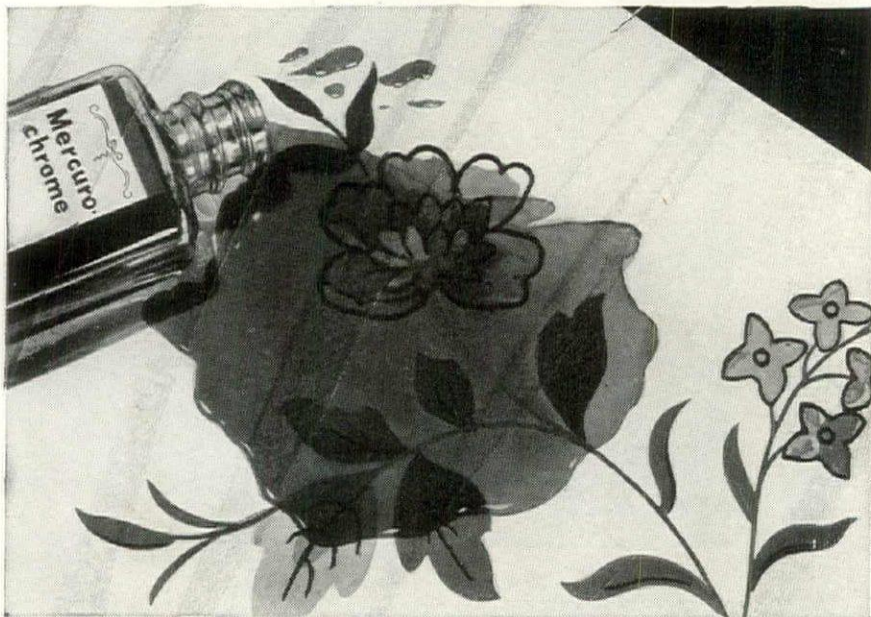

WE SAY you can splatter, smear, write or even walk on Stainproof Varlar—then wash this revolutionary wall covering sparkling-fresh with ordinary soap and water.

Just try to mutilate Varlar's fresh, stainproof beauty. Laboratory tests and actual use prove that oil, ink, grease, jam, crayon, lipstick—STAINS OF ALL KINDS—wash off Varlar quickly, easily with ordinary soap and water.

Even 25,000 washings can't damage Varlar's life-long stainproof beauty. That's because Varlar is made by an entirely new process. Has no surface coating to crack and peel. No brittle, plastic "skin" to chip or discolor. Varlar's rich,

new coloring and stain resistance go clear through, last for life.

Varlar offers architects a versatile new decorating medium of durable beauty and protection...suitable for use in any room or hallway, public or private, domestic or commercial. All 93 stunning styles... florals, plaids, weaves, pictorials, stripes and tones... go up easily as wallpaper.

But don't take our word for it! We dare you to test amazing Stainproof Varlar for yourself. Splatter, smear, write or even walk on it. Then quickly, easily wash it clean with ordinary soap and water. Mail the attached coupon for your test size sample of Stainproof Varlar right away.

Never Before Such Enduring Beauty

VARLAR
Stainproof Wall Covering

VARLAR, Inc.

DIVISION OF UNITED WALLPAPER CHICAGO

ACCEPT THIS CHALLENGE, NOW!

VARLAR, Inc., Dept. P-108
Merchandise Mart, Chicago 54, Illinois

I'll take your dare! Send me free sample of stainproof Varlar and I'll test it for myself.

Name _____

Address _____

City _____ Zone _____ State _____

SPACE HEATER CALCULATOR quickly determines the BTU requirements of a given area.

Designed exclusively for space heater use, this handy calculator quickly figures the number of BTUs required to heat a given area. Calculations are based on the length, width and height of a room, construction of the dwelling and proposed location of the heater. The calculator's reverse side includes specifications of all Perfection and Ivanhoe oil-burning space heaters to aid in the selection of an appropriate heater model.

Manufacturer: Perfection Stove Co., 7609 Platt Ave., Cleveland, Ohio.

ELECTRIC HOT WATER HEATER designed as kitchen secretary.

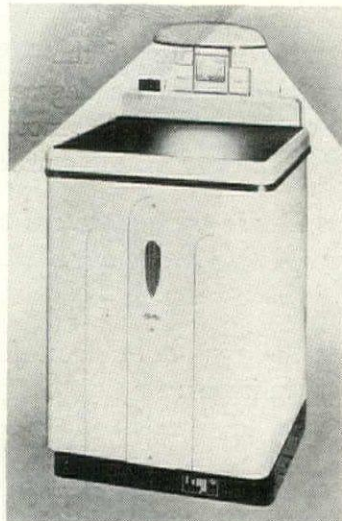

The new Bradford Kitchen Desk Model Electric Water Heater converts the hot water source into a convenient kitchen-secretary complete with built-in linoleum top, desk lamp, paper pencils and minute minder. Among the features of this new unit are Fiberglas insulation, arc-welded copper-bearing steel tanks, super-sensitive adjustable thermostat, special cold water diffusion baffle and, on DeLux Models, the Magnedur Process for tank corrosion protection. The new heater

is constructed to NEMA standards, is U/L approved, measures 25 x 25 x 36 in. Both 30 and 50 gal. sizes are available.

Manufacturer: Pennsylvania Range Boiler Co., 24th & Ellsworth Sts., Philadelphia, Pa.

TWO FLUORESCENT FIXTURES added to Leader Electric line, one for homes, the other for institutions and offices.

Two new fluorescent fixtures have recently been added to the Leader Electric Co.'s line: Model VL 420 Home Unit Luminaire for use in new or remodeled structures and AL Purpose SM-440 for hospitals, schools, stores, libraries, insti-

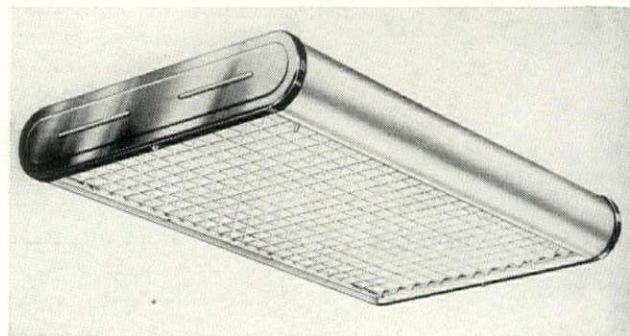

tutions and offices. In the home unit, side panels and louver are made of destaticized plastic which increases efficiency by preventing glare and by diffusing a maximum of light horizontally. End caps are chrome and all reflecting surfaces are baked white enamel. A hinged louver section facilitates the

(Continued on page 136)

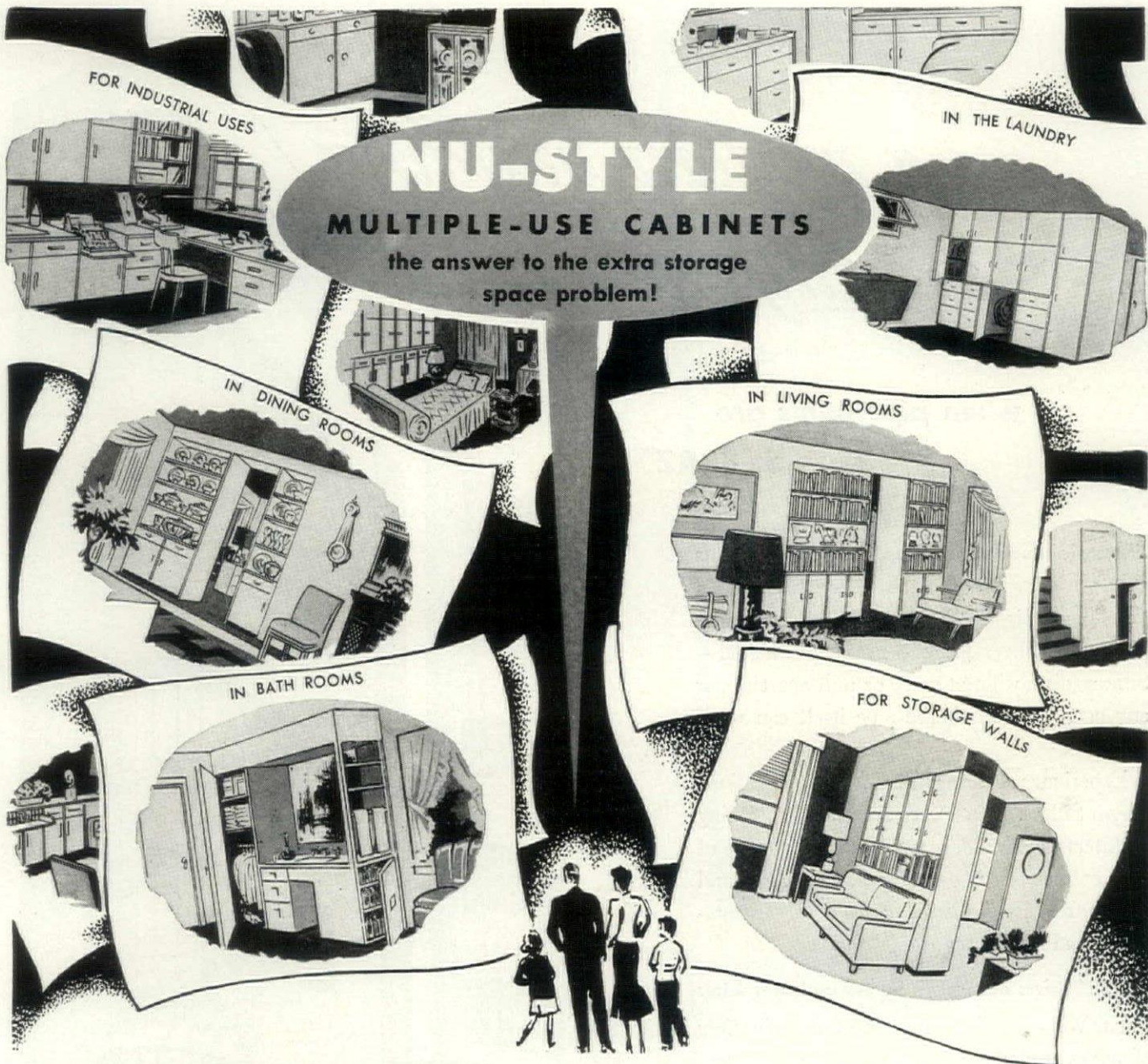

NU-STYLE
MULTIPLE-USE CABINETS
 the answer to the extra storage
 space problem!

FOR INDUSTRIAL USES

IN THE LAUNDRY

IN DINING ROOMS

IN LIVING ROOMS

IN BATH ROOMS

FOR STORAGE WALLS

The Bilt-Well Line

- Superior Unit Wood Windows
- Bilt-Well Interior Doors
- Bilt-Well Exterior Doors
- Nu-Style Kitchen Cabinets
- Bilt-Well Entrances
- Bilt-Well Shutters
- Close-tite Casements
- Bilt-Well Basement Windows
- Bilt-Well Combination Doors
- Bilt-Well Louvres and Gable Sash
- Carr-dor Overhead Garage Doors
- Bilt-Well Corner Cabinets
- Bilt-Well Storm Sash
- Bilt-Well Screens
- Gli-dor Cabinets
- Bilt-Well Medicine Cabinets
- Bilt-Well Ironing Board Cabinets
- Bilt-Well Mantels
- Bilt-Well Telephone Cabinets
- Bilt-Well Stair Parts
- Bilt-Well Unit Linen Cabinets
- Bilt-Well Breakfast Nooks

NU-STYLE Cabinets are designed to fit any area and solve almost any storage problem. They are all-purpose cabinets, and the many standard units in which they come make it possible to use them practically any place.

They are produced from Ponderosa Pine wood, kiln dried, smoothly surfaced, pre-fitted, unfinished, semi-assembled, and packaged in a dust-proof carton.

This is a summary of standard Nu-Style Cabinet Units which are furnished in graduated sizes, thus making them adaptable for various arrangements, of which several illustrations are shown.

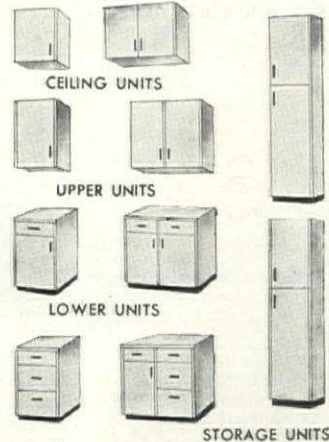

CARR, ADAMS & COLLIER CO., Dubuque, Iowa

*a modern building
is truly modern...*

when pipe joints are
SILBRAZ*

Silbraz joints are threadless, silver brazed joints that, when properly installed, actually make a "one-piece pipeline" on red brass or copper pipe runs. Silver brazed—not soft soldered—Silbraz joints will not creep or pull apart under any condition which the pipe itself can withstand.

Experience covering hundreds of installations where Silbraz joints were specified by leading architects and builders, proves that this type of pipe connection is permanent, leakproof, and troublefree. Its use has avoided costly maintenance and repairs.

Walseal* Valves and Fittings for Making Silbraz Joints

The Walworth Company, oldest manufacturer of valves and pipe fittings in the United States, produces a complete line of Walseal Valves, Fittings, and Flanges for making Silbraz Joints—the modern method of joining brass or copper piping. For further information, see your nearest Walworth distributor, or write for Circular 84E.

*Patented — Reg. U. S. Patent Office

Make it a "one-piece pipeline" with Walseal



WALWORTH
valves and fittings

60 EAST 42nd STREET, NEW YORK 17, N. Y.

DISTRIBUTORS IN PRINCIPAL CENTERS THROUGHOUT THE WORLD

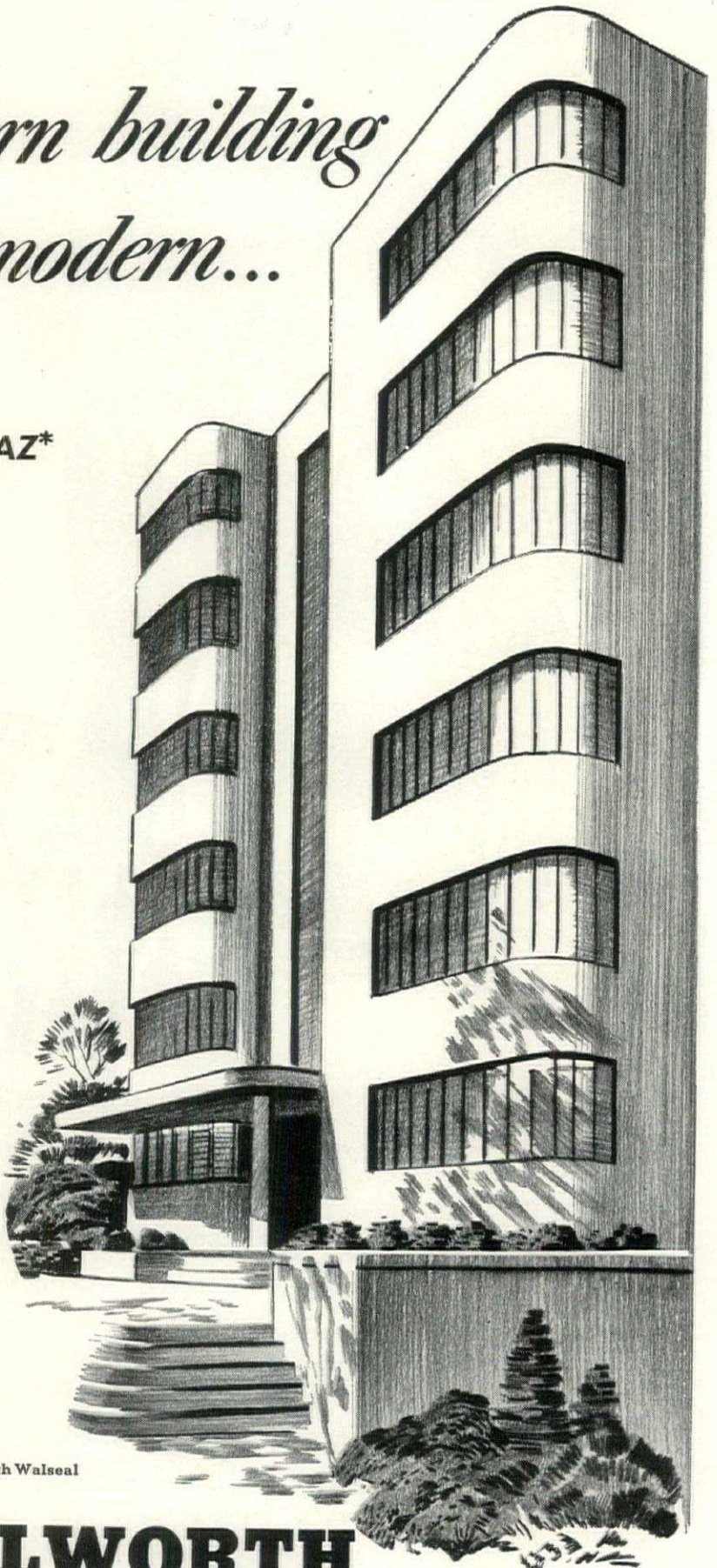

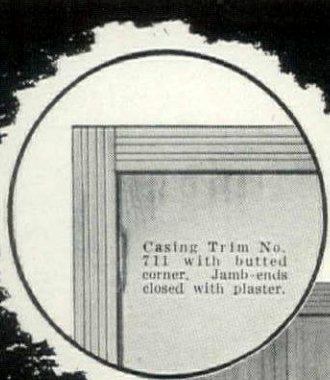

Casing Trim No. 711 with butted corner. Jamb-ends closed with plaster.

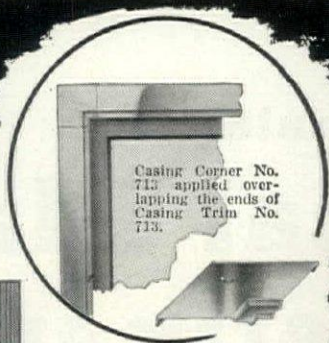

Casing Corner No. 713 applied over-lapping the ends of Casing Trim No. 713.



Casing Trim No. 711 with mitred corner held in place by Mitre Brace No. 7.

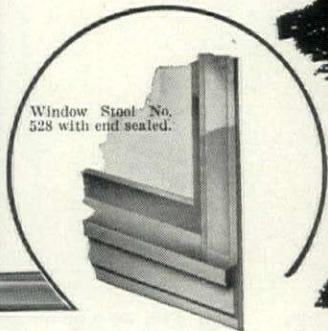

Window Stool No. 528 with end sealed.

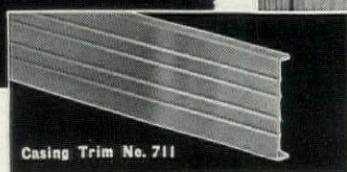
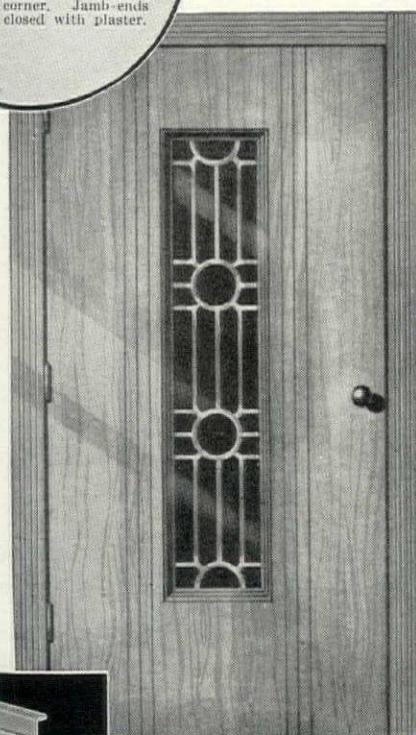

Casing Trim No. 711



Casing Trim No. 712

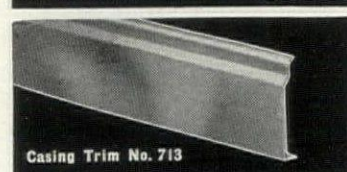

Casing Trim No. 713

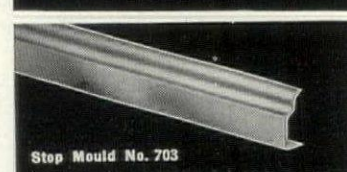

Stop Mould No. 703



Window Stool No. 528



Base Trim No. 646

Milcor Applied Residential Trim

... Easy and economical to install after plastering..for the lasting beauty of STEEL

Quickly Installed!

The builder simply screws Milcor Applied Residential Trim directly to the rough bucks or to wood grounds. Matching accessories finish corners and ends (in most cases, it is unnecessary to mitre or cut casings to exact length) — or you can butt, cope, or mitre at corners. To reduce painting time and costs, Milcor Applied Casings and Trim come with a rust-inhibitive primer coat of paint.

Permanent!

Because they are made of 22-gauge steel, these casings and base trim provide definite advantages over trim of less durable material: They cannot

warp, split, crack, splinter, or rot. They cannot be damaged by mice, rats, or vermin. They cannot burn. They offer greater resistance to impact and shock. They last for the life of the building.

Versatile!

There are three styles of casing trim, two styles of base trim, a stop mould, and a window stool—all available. Accessory fittings include cast corner fittings, and closures, formed corner covers, and a mitre brace—all of the same contour and style as the trim sections.

For further information, write on your business letterhead for Milcor Applied Residential Trim bulletin.

INLAND STEEL PRODUCTS COMPANY

FORMERLY MILCOR STEEL COMPANY



MILWAUKEE 1, WISCONSIN

BALTIMORE 24, MD.
CINCINNATI 25, OHIO
KANSAS CITY 8, MO.

BUFFALO 11, N. Y.
CLEVELAND 14, OHIO
LOS ANGELES 23, CALIF.
ROCHESTER 9, N. Y.

CHICAGO 9, ILL.
DETROIT 2, MICH.
NEW YORK 22, N. Y.

**Planning a
Chemical Plant
Oil Refinery
Paper Mill,
... or an addition**

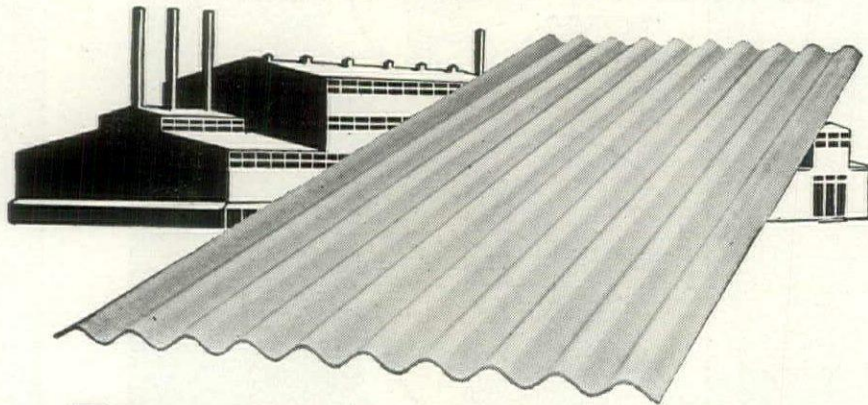

**You can now get
ASBESTONE**

Asbestos-Cement Corrugated Roofing & Siding

—the lifetime roofing and siding that's fireproof and corrosion-proof. Asbestone can't be damaged by weather, rats, or termites. No painting. No upkeep.

Here are a few of the many prominent users:

- LONE STAR CEMENT CORP.
- CALIFORNIA OIL CO.
- CHAMPION PAPER and FIBRE CO.
- ETHYL CORPORATION
- FREEMPORT SULPHUR CO.
- NEW ORLEANS PUBLIC SERVICE
- MOBILE PAPER MILL CO.
- CROSBY CHEMICALS, INC.
- STANDARD OIL OF N. J.
- UNIVERSAL ATLAS CEMENT CO.

Why we can assure you early delivery

We are concentrating on production of this single industrial product. Stocks are now ample to make some immediate shipments. Free Engineering Service, available on request, shows how Asbestone can be adapted to your needs.

ASBESTONE CORPORATION

5300 TCHOUPITOULAS STREET NEW ORLEANS 15, LA.

Specialists in Asbestos-Cement Building

Products for over 25 Years

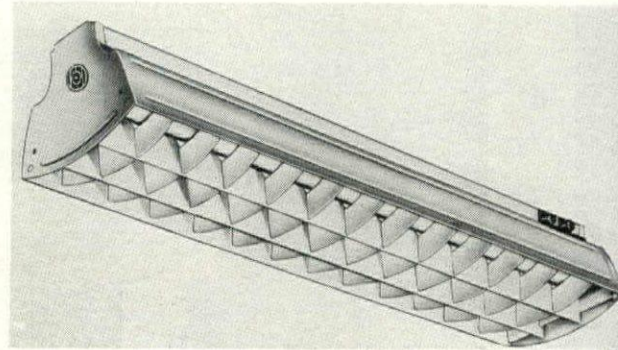

replacement of tubes. All-Purpose SM-440 Luminaire is described by the manufacturer as a powerful lighting unit which diffuses equalized and gentle brilliance over great areas. It provides 40 per cent upward diffusion, 60 per cent downward diffusion and affords 35° and 25° shielding with metal louvers. An all metal fixture finished in high gloss white baked-enamel, its louvers swing down and are removable. Starters are externally mounted for easy access.

Manufacturer: Leader Electric Co., 3500 N. Kedzie Ave., Chicago, Ill.

KITCHEN COUNTER LIGHT mounts under cabinets, throws light on counter.

Installed easily under wood or metal kitchen cabinets in order to throw light down on the work counter, Guardian's low-cost

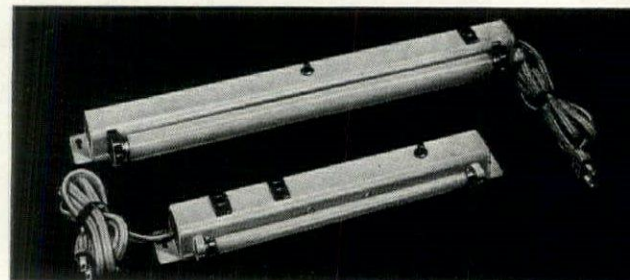

fluorescent kitchen fixture comes in 8 w. and 15 w. sizes. The 8 w. unit fits all standard cabinets while the 15 w. size is used with wider cabinets or for large work areas. Both units are constructed of enameled steel for long, trouble-free service and both are supplied with either knock-outs for permanent installation or cord and plug for portable use. A sturdy instant start switch and either one or two standard convenience outlets are other features.

Manufacturer: Guardian Light Co., 301 Lake St., Oak Park, Ill.

TUBULAR LOCK effects time and cost savings.

Yale's new Heavy Duty Tubular Lock is designed for simplicity in operation and speed in installation. The key-in-knob 6-pin tumbler locks are assembled at Yale & Towne's Stamford division into the "exploded" unit illustrated, then packaged in their relative positions ready for easy step-by-step installation on the job. Company engineers claim a saving of 80 per cent in costly construction time over older locksets in installing the mechanisms in quantity. Complete assembly time, after boring of the two holes required to house the lock, is held to be as low as 30 seconds. This cost reduction in installation time results from such features as the elimination of full mortising, and the "pre-installation assembly" at the factory. The new line contains five basic locksets, four with

(Continued on page 140)

To get *just* what you want in a **SOUND** system . . .

call the man behind this sign...



NO two sound distribution problems are ever exactly the same—so *your* system must be engineered to meet *your* specific needs.

Chances are you wouldn't be satisfied with a "packaged," take-it-or-leave-it job. Nor would you want to pay for a system in which all equipment had to be specially designed and made for you.

That's why Western Electric Sound Dealers follow a middle course. Choosing the right "building blocks" from a *complete* line of Western Electric components—all engineered to fit together in unlimited combinations—they custom-build your system to give you *just* what you want.

Hundreds of Western Electric installations prove the rightness of this method. You, too, can count on your Western Electric Sound Dealer—backed by sound specialists at Graybar Electric, Western Electric and Bell Telephone Laboratories—for a flexible system that delivers highest quality reproduction of voice and music.

Look for his name in the Classified Section of your Telephone Directory—under "Sound Systems." If there is no Western Electric Sound Dealer listed in your city, ask Graybar Electric Company, 420 Lexington Avenue, New York 17, N.Y. for the name and address of the one nearest you.

—QUALITY COUNTS—

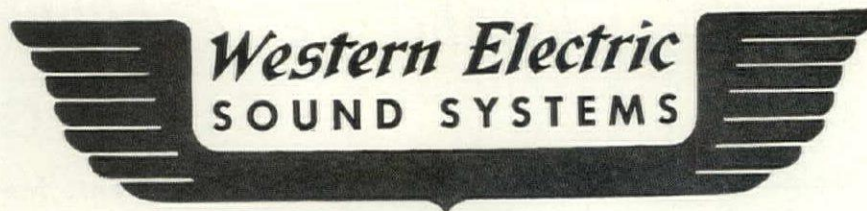

DISTRIBUTORS: IN THE U.S.A.—Graybar Electric Company. IN CANADA AND NEW-FOUNDLAND—Northern Electric Co., Ltd.

It's time to forget previous ideas about Aluminum siding!

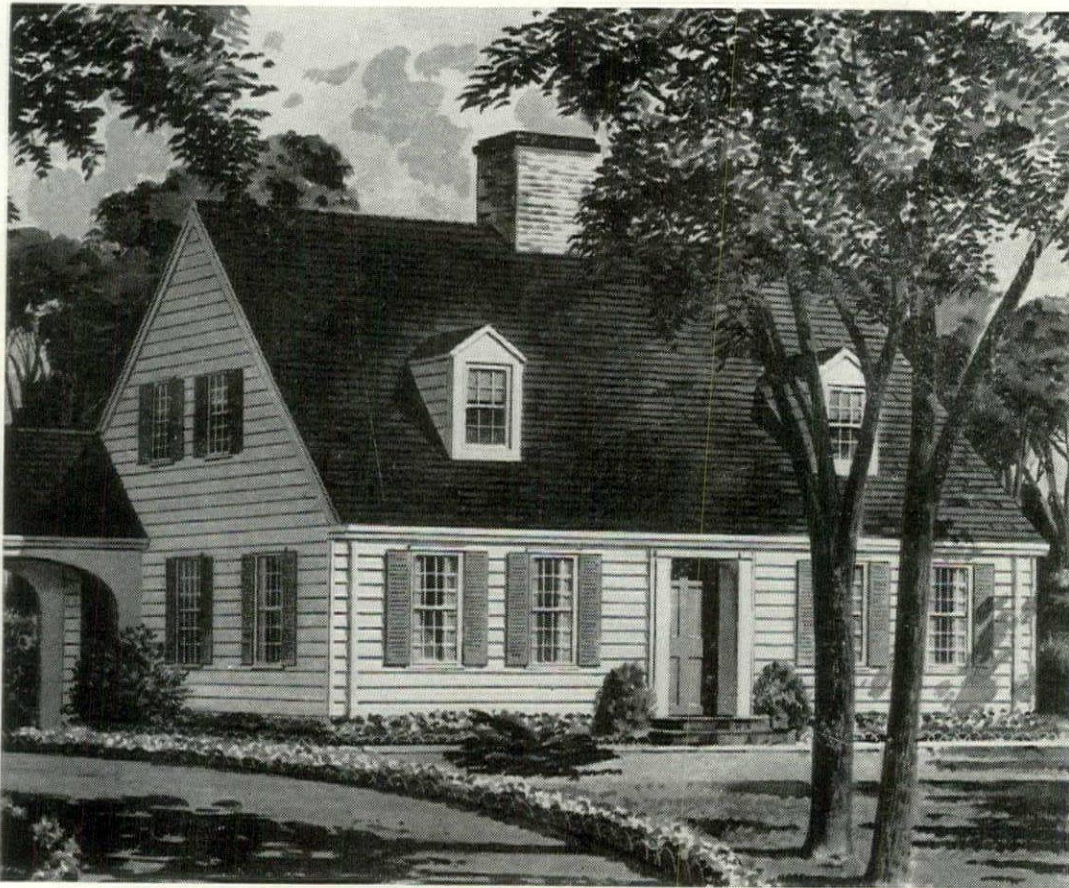

Kaiser Aluminum Siding is a completely new kind of building material, made of highest grade aluminum, roll-hardened by precision machinery. It's a strong dent-resistant siding with permanent beauty unmarred by knots, splits or sawing scars.

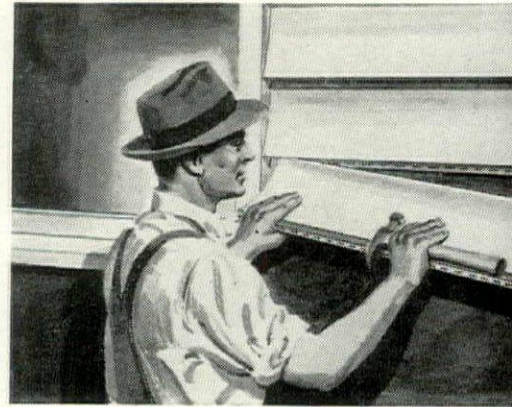

So—first of all—forget about waves or buckles with Kaiser Aluminum Siding! It has a pre-formed curved surface! As each piece is nailed down, the curve produces a rigid tension which eliminates distortion.

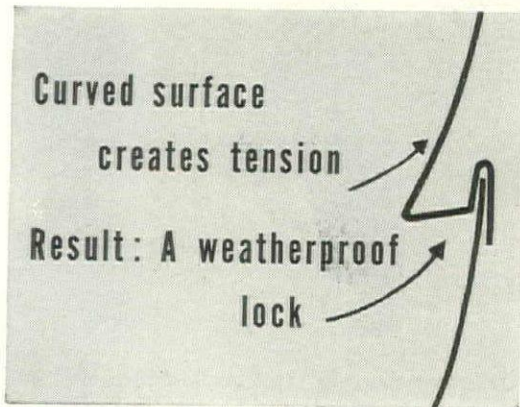

And this exclusive curved surface does even more. It is a deliberately engineered feature which makes this the strongest aluminum siding ever known. When lower edges are nailed down, the curve creates a tension which results in absolutely weathertight joints. And it creates beautiful clean lines.

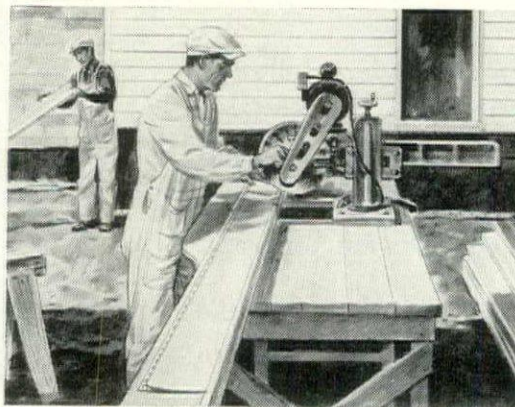

Forget about high costs with Kaiser Aluminum Siding! It actually saves you money in many ways. Its light weight speeds construction, cuts labor costs—and its application requires no special tools. What's more, it takes fewer nails and its non-porous surface requires less paint. Paint goes on faster, too!



Your clients can forget about maintenance! Kaiser Aluminum Siding will never rot, rust, warp or crack in any climate! It's fire-resistant, can't be damaged by rats or termites. It comes from the mill with its surface especially prepared and prime coated to assure firm paint adherence and lasting finishes.

No other material can match the unique combination of advantages of Kaiser Aluminum Siding! Write for booklet packed with information, pictures and diagrams explaining this modern new material!

Kaiser Aluminum Siding specifications:

Length	. . . 10, 12, 14 and 16 ft. standard lengths	Thickness030"
Width	. . . 6 1/2"		
Weight	. . . 580 lbs. per 1146 base feet (1000 sq. ft.)		
Shipped in cartons containing 200 base feet, weighing 106 lbs. overall.			

Kaiser Aluminum

SIDING

product of Permanente Metals Corp.

SOLD BY PERMANENTE PRODUCTS COMPANY, KAISER BUILDING, OAKLAND 12, CALIFORNIA . . . WITH OFFICES IN:
 Atlanta • Chicago • Cincinnati • Cleveland • Dallas • Detroit • Houston • Indianapolis • Kansas City • Los Angeles • Milwaukee • Minneapolis • New York
 Oakland • Philadelphia • Portland, Ore. • Salt Lake City • Seattle • Spokane • St. Louis • Wichita

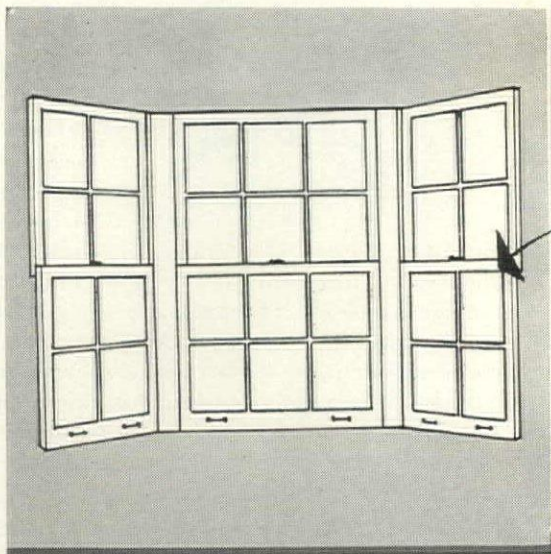

Bay windows like this are easy to assemble from Ponderosa Pine stock units. This one consists of a center double-hung unit with 12 lights, flanked by two double-hung units, each with 8 lights. Remember, too, that Ponderosa Pine double-hung or casement windows are unusually effective when used in groups.

LESS OUTPUT FOR OUTLOOK

“BRING the outdoors in—but watch the budget!” That’s the exacting demand made by hundreds of prospective home owners today. But large glass areas, lavishly used, can be expensive—as every architect and builder know. What, then, is a reasonable middle ground?

Windows of Ponderosa Pine provide the sensible answer. Available in a wide variety of styles, including prefit modular standard sizes, they capture the substantial economies of mass production. You can use them generously without putting an undue burden on building costs. And, in doing so, you give owners the superior value of Ponderosa Pine which sands so smoothly, takes paint or other finishes so beautifully. And remember, Ponderosa Pine doors and windows are obtainable toxic preservative treated!

As a source of inspiration and ideas for using Ponderosa Pine windows, you’ll want “Today’s Idea House”—32-page booklet crammed full of interesting and unusual photographs. A copy is yours for the asking—just mail the coupon.

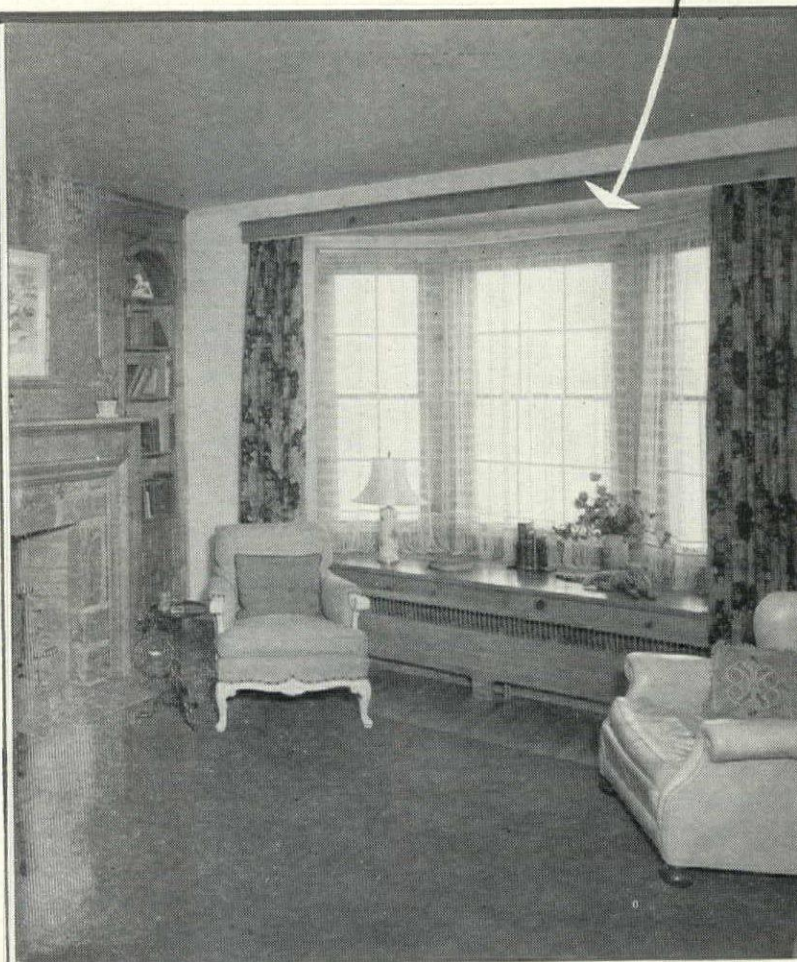

For Friendly Living..
Ponderosa Pine
WOODWORK



Ponderosa Pine Woodwork
 Dept. RAF-10, 38 South Dearborn Street
 Chicago 3, Illinois

Please send me a copy of "Today's Idea House." (Please print)

Name.....

Address.....

City..... Zone..... State.....

THE
Commodore
Shower Cabinet
DESIGN NO. 2000-C



The finest in shower cabinet design and construction, now again available for installation in bathrooms where the ultimate in luxury is desired. Back wall panels are white vitreous porcelain enamel, glass panels set in solid brass chromium plated frame. Receptor deep type terrazzo generous size with overall dimensions 40"x40"x80". Architects, Builders and home owners will welcome back this Fiat shower cabinet that typifies luxury shower bathing equipment.

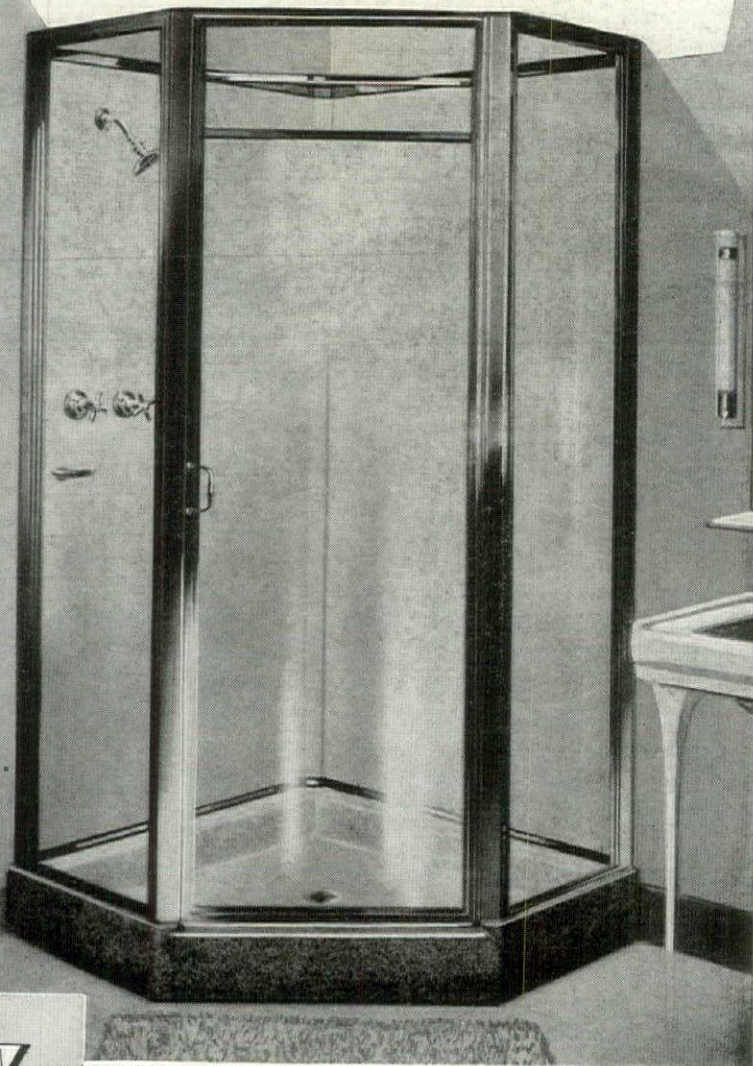

Metal Manufacturing Company

1203 ROSCOE ST., CHICAGO 13, ILL.
LONG ISLAND CITY 1, N. Y. LOS ANGELES 33, CALIF.

In Canada Fiat showers are manufactured by Porcelain and Metal Products, Ltd., Orillia, Ont.

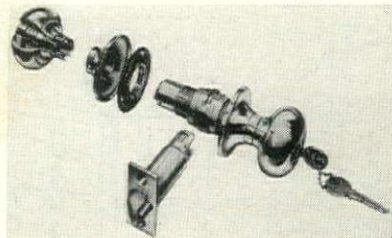

an optional deadlocking bolt, to make a total of nine different models. All the important lock functions, from connecting doors with plain latchbolts to entrance doors with double lock

cylinders, are included. All models are uniform in appearance and completely interchangeable—only variations are in the inner component parts of the knob assemblies. Locks can be reversed on the job for last minute changes in plans. Adjustment can be made for varying door thicknesses from 1 3/8 in. to 1 3/4 in. by means of a clamping nut in the inner rose. Made of pressure formed metals, the locks are furnished in either polished or dull brass, bronze or chrome.

Manufacturer: The Yale & Towne Manufacturing Co., Stamford, Conn.

TUBULAR LOCK for wood or metal doors offers ease of installation and universal use.

Sargent's new *Dualock* is a simple bored-in lock design with a number of features which suit the lock for installation in numerous varying door types, both wood and metal. A self aligning feature makes the lock relatively independent of the door for precise functioning, and the lock has a compact mechanism which necessitates only a small cross bore. It is equipped with an aligning tube of high pressure cast aluminum which furnishes the necessary support to hold the lock in place and—once the lock is assembled—assures alignment.

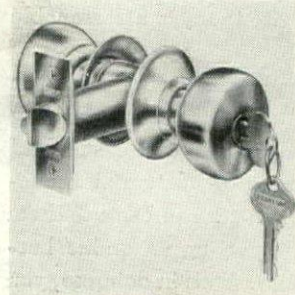

Roses are applied without screws. The Dualock requires only a 1 3/8 in. diameter hole to be drilled in the face of the door, which can be drilled with a standard bit. The required hole in the door edge is only 1 in. in diameter. These locks are suitable for wide use, since they can be installed on a regular bevel door or a

reverse bevel door, either right or left hand, without changing any parts. To accommodate the various locking and latching functions, five types are available. Screwless application of the roses permits their equal adjustment for doors from 1 3/8 in. to 1 3/4 in. thick, enabling the knobs to project an equal distance from both door faces under all conditions. No grub screws are necessary for the knobs; the outside knob is permanently fastened to the spindle and the inside knob is held with a spring retainer.

Manufacturer: Sargent & Co., New Haven, Conn.

PLASTIC WASH BASIN AND SINKS in pastel colors are very lightweight and durable.

Colorful plastic wash basins and sinks which compare favorably in price with standard china and porcelain fixtures are now being commercially produced for use in homes, boats, planes and trains. Extremely lightweight and shatter-resistant, these Lucite products are unaffected by hot water or food acids and are reported to stand up indefinitely with ordinary care. They can be cleaned with soap and water or, if desired, may be waxed for added luster. The manufacturer cautions against the use of a few chemical compounds found in the home and against the plac- (Continued on page 144)

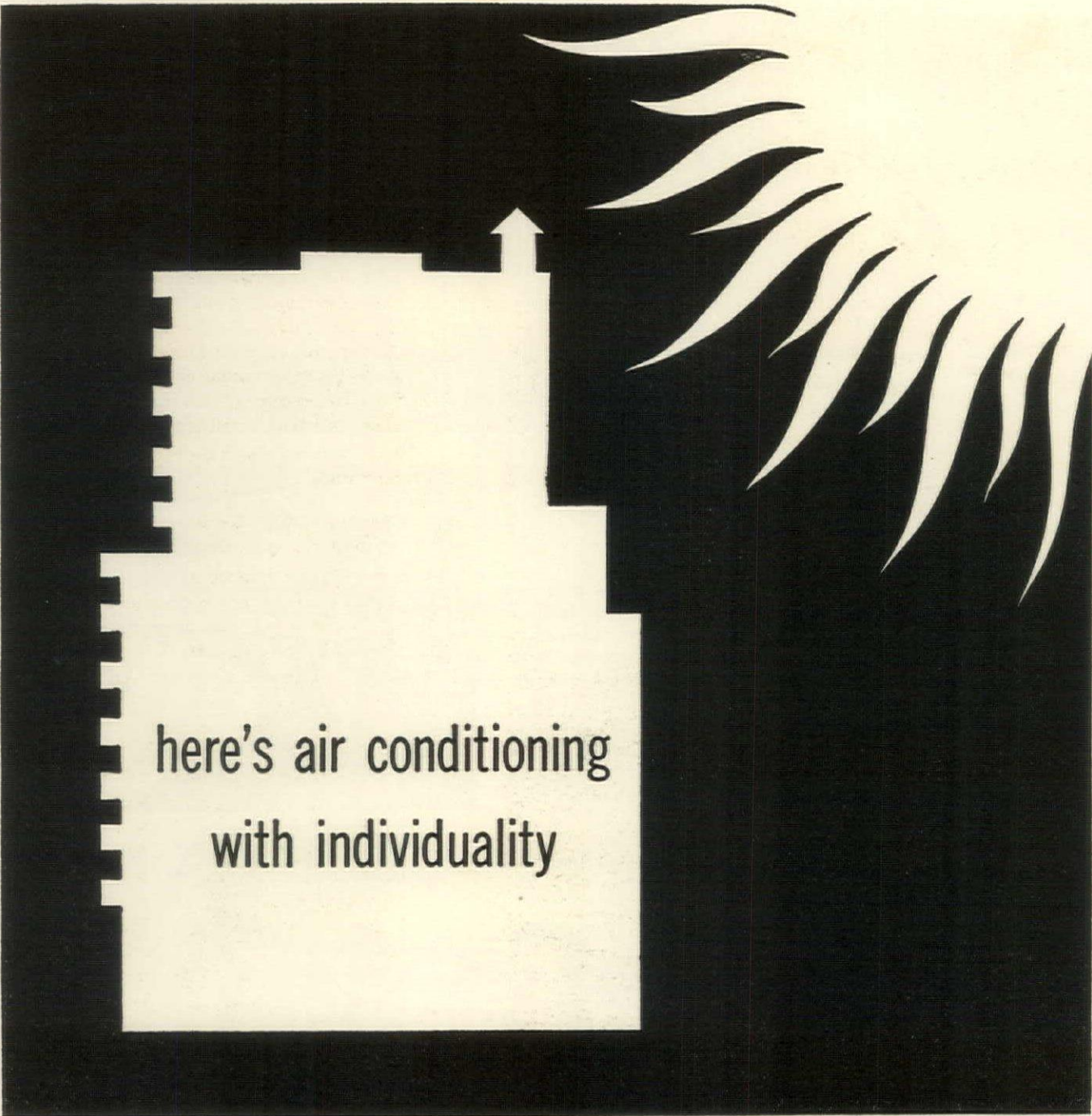

here's air conditioning
with individuality

Now it's possible to plan ideal indoor weather for every room in any multi-story building regardless of its location, variable occupancy, or alternate exposure to sun and shade. It may be exposed longer to the sun than others . . . may get the full blast of icy winter winds. Yet the Carrier Conduit Weathermaster System permits complete control of temperature and humidity in individual rooms at any

season of the year. A turn of the individual knob gives the occupants *exactly* the kind of weather they want.

This revolutionary year-round system supplies outside air continuously. Use of small-diameter conduit instead of bulky supply and return ducts saves *rentable* floor space . . . and often a story height in new buildings.

The Carrier Conduit Weathermaster System is the latest product

of the engineering skill that *created* air conditioning . . . and has led the way to every important advance.

For years, Carrier engineers have teamed up with architects and their consulting engineers to provide the utmost in efficient and dependable air conditioning. Write for the booklet "Air Conditioning for Multi-Room Buildings." Carrier Corporation, Syracuse, New York.

Carrier

AIR CONDITIONING • REFRIGERATION • INDUSTRIAL HEATING

Micartabord, $\frac{5}{32}$ " for corridors and elevator cabs; Micarta Laminate, $\frac{7}{8}$ " and $1\frac{1}{4}$ ", for furniture tops; Micarta Sheet, laminated to plywood, $\frac{1}{16}$ " for desk fronts and tops.

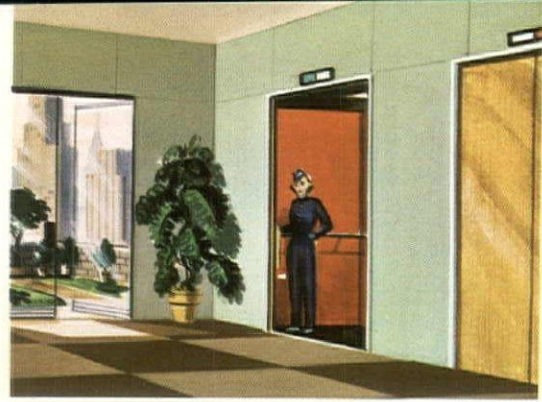

Check these 34 Uses for

MICARTA.

Micarta tops for tables, bars and fountains. Micarta bar and fountain fronts, where careless customers so often snuff out cigarettes. With Micarta, no damage results.



Micarta for table tops, and fixtures. Micarta for its sheer decorative qualities. Micarta for gleaming, clean appearance easy to keep that way.

Micarta for sink and counter tops in kitchens, serving pantries, diet kitchens — wherever stubborn resistance to wear and sanitary cleanliness are essential.



*How many ways
do you employ this tough,
beautiful material?*



HAVE you thought of Micarta* as ideal, chiefly for table and counter tops? If you have, consider how extensively this bright, colorful, good-looking, easy-to-clean plastic laminate is going into operating rooms, toilets and bathrooms, kitchens, elevator cars, and scores of other places in homes, stores, bars, restaurants, hotels and institutions.

Wherever long-time attractive appearance is important, Micarta offers stubborn resistance to wear, abrasion, marring and abuse.

In fact, Micarta requires virtually no maintenance. It is unaffected by boiling water, household cleansers, detergents, dilute acids, condiments, milk, grease, food products, and barber and beauty shop preparations (including hydrogen peroxide up to 8 hours) and even nail polish and remover.

Micarta is highly resistant to cigarette burns but for complete protection, a special cigarette-proof grade is made. This is important in public eating and drinking places where stubs are allowed to smoulder on table tops, or are snuffed out against bar and counter fronts.

The type of *service* determines the type of Micarta you'll want to use. Check the table in the panel above.

WORKABLE: Micarta can be worked by hand tools on the job. It can be sawed, trimmed, planed and drilled. For samples, added information, prices, deliveries, etc., use coupon below.

*Reg. U. S. Pat. Off.



A.F.

UNITED STATES PLYWOOD CORPORATION

New York 18, N. Y.

If you think you can mar Micarta

try these "demolition" tests: **Try to score it**
Try to dent it
Try to stain it
Try to spoil it

1/16" MICARTA SHEET

This form is the type used as a "work surface" by fabricators who have the necessary bonding equipment, and is incorporated into table tops, bar tops or counters for:

Uses

Bars
Barber shops
Beauty parlors
Coffee shops
Dinettes
Furniture tops
Kitchen cabinets
Kitchen sinks
Laboratories
Laundries
Lunch rooms
Restaurants
Retail stores
Rumpus rooms
Soda fountains
Utility rooms
Work surfaces

Sizes 30" x 84"
30" x 60" 36" x 84"
36" x 72" 48" x 96"

7/8" and 1 1/4" MICARTA PANEL

This is 1/16" MICARTA SHEET bonded to special cores of Philippine mahogany-faced plywood. It saves fabricators the trouble and expense of doing their own bonding.

Uses

Same as those listed at left, plus occasional use as a structural material.

Size

48" x 96"



MICARTA
is manufactured by
WESTINGHOUSE
and sold, for
decorative purposes
only, by
UNITED STATES
PLYWOOD
CORPORATION

5/32" MICARTABORD

This type is used generally as a wall surfacing material. It is easy to apply over finished walls.

Uses

Back bars
Bathrooms
Beauty parlors
Corridors
Counter fronts
Diet kitchens
Elevator cars
Filling stations
Operating rooms
Restaurants
Specialty shops
Stores
Toilets
Wainscoting
Walls
Washrooms
And as kick plates
and push plates

Size

48" x 96"

COLORS

TRUWOOD

This is a special type of MICARTA SHEET with a true wood veneer top sheet in:

Korina Primavera
Mahogany Walnut

Other woods on special order. (Truwood is not available in Micartabord)

SOLID COLORS

Blue Medium Blue Green
Bisque Wedgewood Blue
Gray Grayed Yellow
Beige Chinese Red
Brown Light Gray Green
Green Carmine Red
Yellow Grayed Rose
White Light Gray
Black Dark Blue

PATTERNS

Linen Foam
Mother of Pearl
Tan
Blue
Pink
Green
Yellow
Copper

FINISHES All colors and all types of Micarta are supplied in highly polished mirror-finish or in satin finish.

UNITED STATES PLYWOOD CORPORATION

New York 18, N. Y.

If you think you can mar Micarta

try these "demolition" tests: **Try to score it**
Try to dent it
Try to stain it
Try to spoil it

United States Plywood Corporation

55 West 44th Street, New York 18, N. Y.

I WANT TO GIVE MICARTA THE "THIRD DEGREE". Without any obligation whatever, send me, *free*, a sample of Micarta so I can see for myself how beautiful, tough, wear-resisting and abuse-proof Micarta really is:

NAME _____ TITLE _____

COMPANY _____

ADDRESS _____

**cornerstone
of
today's
big
building**

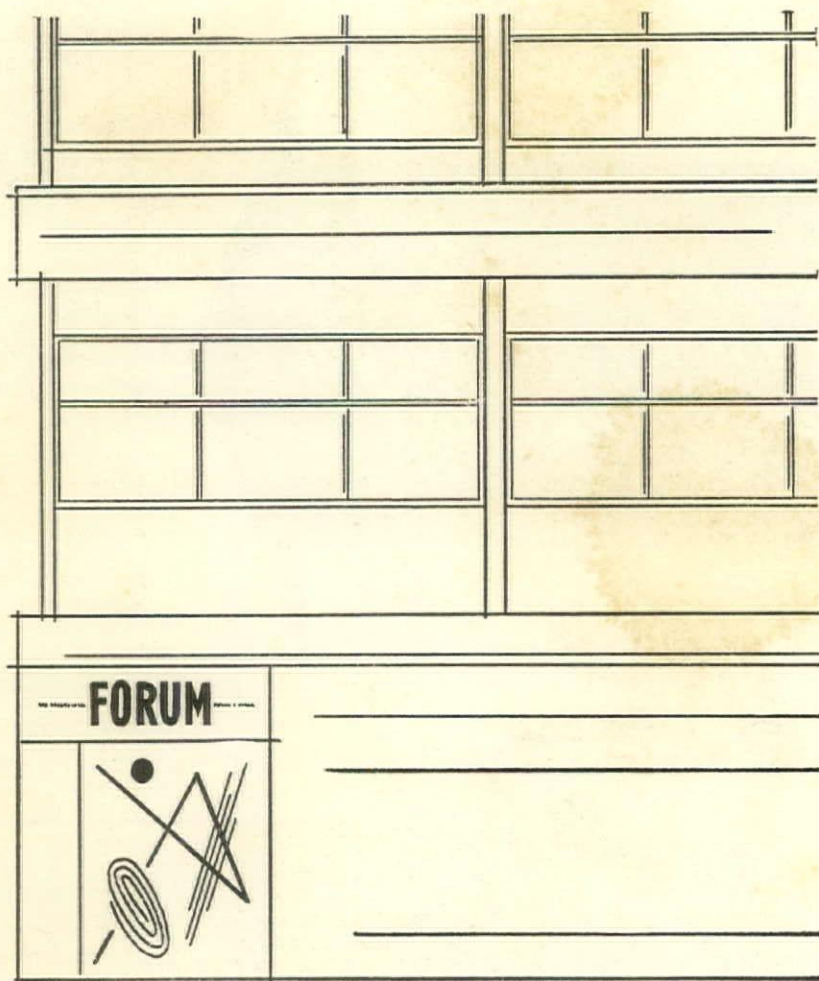

No one, so far as we know, has ever placed a copy of The Architectural FORUM in a cornerstone.

But they might very well... for the FORUM has been a cornerstone of progressive building since 1932. FORUM is the preferred publication where designers like to see their work in print. And FORUM, edited by the largest staff of experts in the building field, is the *only* medium that horizontally covers every common denominator of building, from design and construction to management and financing.

Repeatedly, FORUM has proved itself the strongest single publishing influence behind contemporary building. And progressive building professionals, who must hold their leadership by constant acquaintance with every aspect of their industry, look regularly to the FORUM.

Its power with these men who control major building... and the effectiveness and economical cost with which it reaches them... logically makes the FORUM a cornerstone, too, of any advertising campaign addressed to the top buyers in the building industry.

The Architectural **FORUM** Magazine of Building

Division of TIME, Inc., 350 5th Avenue, New York 1, N.Y.

KEWANEE[☆]

SQUARE-HEAT TYPE R[☆] in two-tone SMARTLINE[☆] Jacket

For the
"New Look"

Matching the simplified and improved design Kewanee Square Type "R" is now available in a new "Smartline" insulating jacket.

It's a *saving feature*. Heat is held in the boiler by a "Fiberglas" lining while the entire installation is beautified by the two-tone green steel casing.

The jacket is quickly assembled either on a new job or on a boiler already installed, without disconnecting the piping.

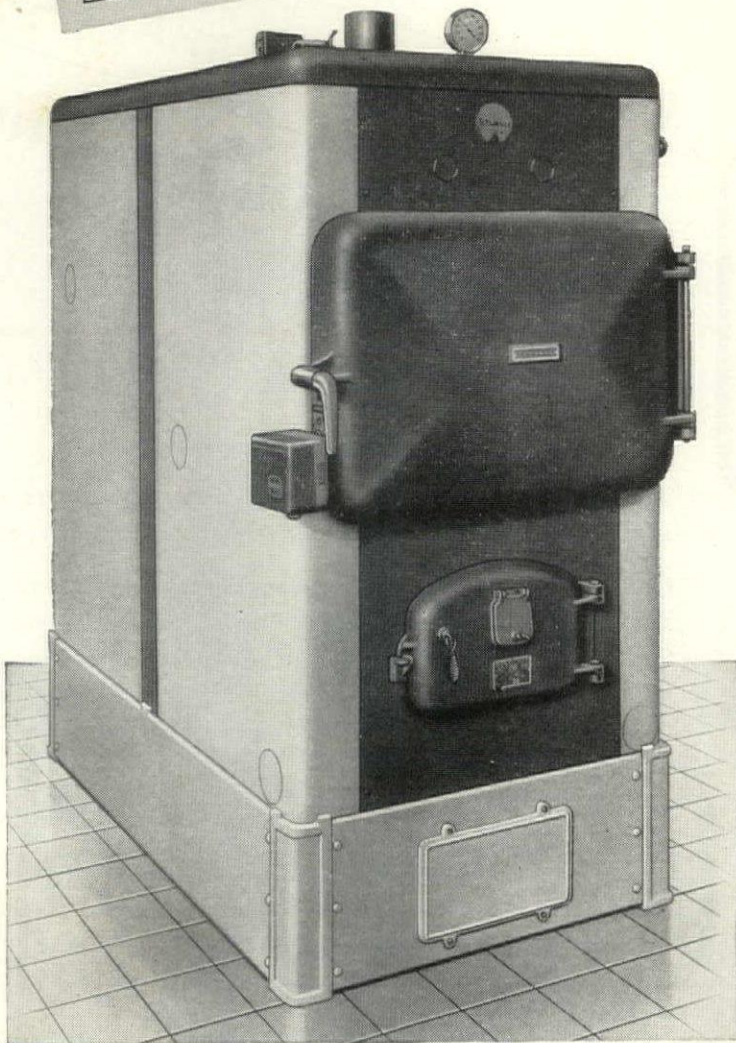

8 sizes for heating medium size buildings 740 to 3000 sq. ft. with any fuel. Each size embodies all the features which have made the large Kewanee Boilers so outstanding in efficiency, dependability and durability for 80 years.

[☆] Reg. U. S. Pat. Off.



Reg. U. S. Pat. Off.
MEMBER

KEWANEE BOILER CORPORATION

KEWANEE, ILLINOIS

Branches in 60 Cities—Eastern District Office: 40 West 40th Street, New York City 18

Division of AMERICAN RADIATOR & Standard Sanitary CORPORATION

OVER
75 YEARS
BOILERMAKERS

First choice for **COMMERCIAL**

"QUALITY-APPROVED"

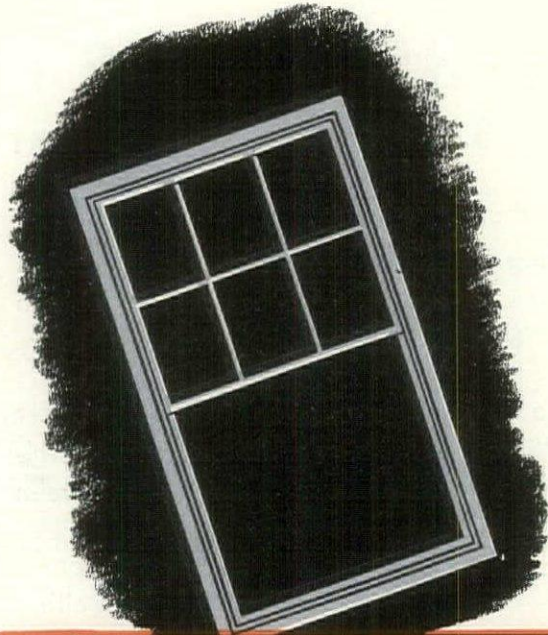

This Seal

MEANS "QUALITY-APPROVED"

WINDOWS THAT MEET THE

HIGHEST STANDARDS

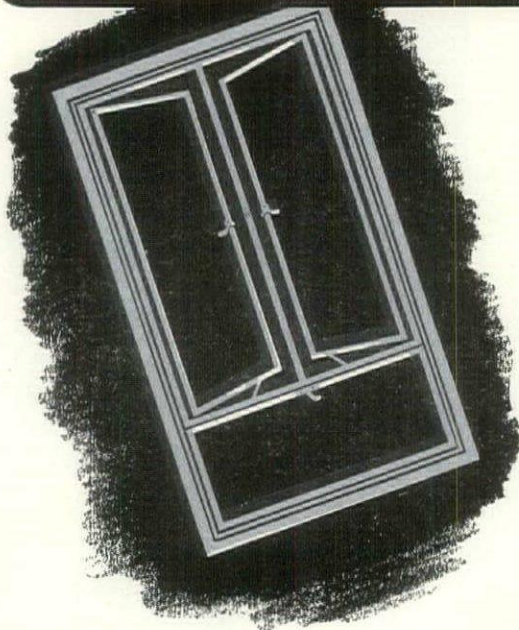

How to *make sure* of quality aluminum windows?

This is an important question to architects, builders and owners as aluminum windows become "first choice" for *all* types of building.

Certain manufacturers today can answer this question to your complete satisfaction. Their aluminum windows bear the "Quality-Approved" Seal of the Aluminum Window Manufacturers Association. The windows have been tested by the Pittsburgh Testing Laboratory and conform to the rigid specifications established by the Association.

This seal assures you of aluminum windows that meet the highest standards for quality materials, strength of sections, soundness of construction, and minimum air infiltration.

Your clients are assured of aluminum windows that are good looking, easy-to-operate, require minimum maintenance, never need painting, give years of trouble-free service.

Select *only* aluminum windows bearing the "Quality-Approved" Seal and be sure. Write for information and names of manufacturers whose windows qualify for the Quality Seal.

MONUMENTAL *and* **RESIDENTIAL** *buildings*

ALUMINUM WINDOWS

1

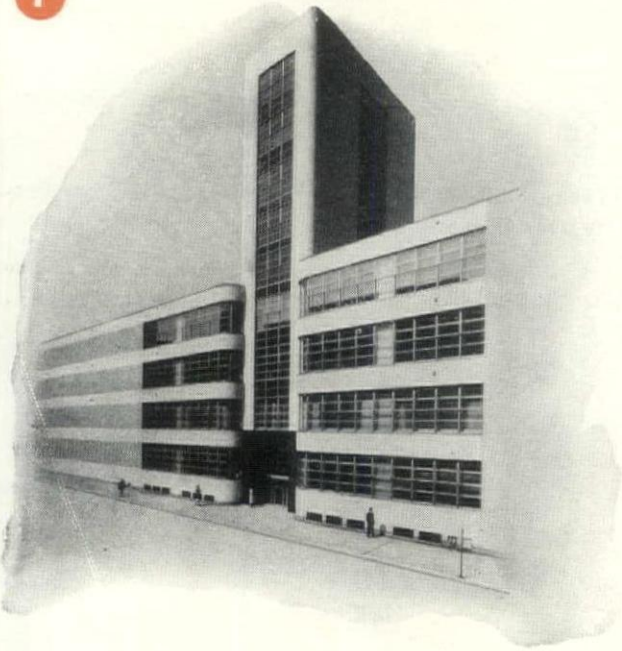

2

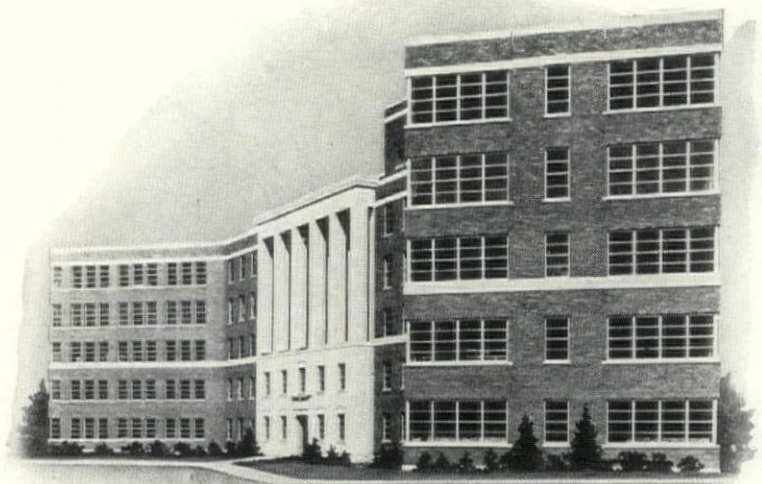

3



1 For **COMMERCIAL** and **INDUSTRIAL BUILDINGS** aluminum windows are ideal. They never need painting, keep maintenance costs at a minimum. Shown above: The Newman-Rudolph Building, Chicago, Ill.; A. S. Alschuler, R. N. Friedman, Architects.

2 For **MONUMENTAL** and **INSTITUTIONAL BUILDINGS**—where beauty as well as utility are important—good-looking, long-lasting aluminum windows are first choice. Pictured upper right: Helen Rivas Clinic, Rochester, N. Y.; Kaelber & Waasdorp, Architects; A. W. Hopeman & Sons, Contractors.

3 For **RESIDENTIAL BUILDINGS**, both single and multi-family units, aluminum windows are preferred for their appearance, ease of operation and freedom from periodic painting. Shown at right: Residence in Huntington Station, N. Y.

Aluminum Window Manufacturers Association

209 CEDAR AVENUE, TAKOMA PARK, WASHINGTON 12, D. C.



There's a very good reason why sales of automatic Electric Water Heaters are going ahead by leaps and bounds to record heights—home owners prefer them! To have your customers completely satisfied with the homes you build—both now and in years to come—install the kind of water heating equipment they want.

How to reduce construction costs and add customer features . . .

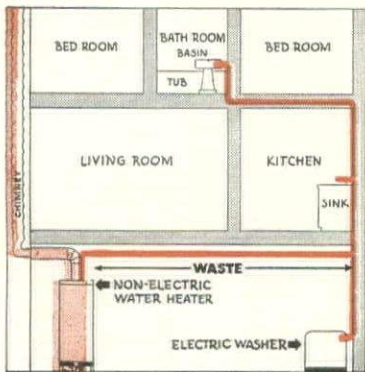

NON-ELECTRIC INSTALLATION

Construction costs can be reduced with Electric Water Heaters because there's no flue or vent, so installation can be made anywhere—in a closet, in the kitchen, in the bathroom, in the utility room. Hot water lines can be short, cutting piping cost.

Customers like Electric Water Heaters

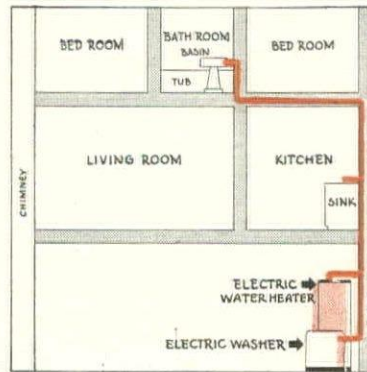

ELECTRIC INSTALLATION

because they are: (1) **AUTOMATIC** (continuous hot water, no attention); (2) **CLEAN** (smokeless, sootless); (3) **DEPENDABLE AND TROUBLE-FREE** (as electric light); (4) **ECONOMICAL** (fully insulated storage, short hot water lines); (5) **SAFE** (all-electric dependable temperature control); (6) **FLEXIBLE** (can be installed anywhere, even in living quarters; no flue or vent).

Electric Water Heater Section NATIONAL ELECTRICAL MANUFACTURERS ASSOCIATION
155 East 44th Street, New York 17, N. Y.

B & F • BRYANT • FOWLER • FRIGIDAIRE • GENERAL ELECTRIC • HOTPOINT • HOTSTREAM
JOHN WOOD • JUD WHITEHEAD • KELVINATOR • MERTLAND • MONARCH • NORGE
PENCO • REX • RHEEM • SELECTRIC • SEPCO • SMITHWAY • SUNBEAU
THERMOGRAY • TOASTMASTER • UNIVERSAL • WESIX • WESTINGHOUSE

IT'S EASY TO INSTALL an electric WATER HEATER!

... in a house wired for an Electric Range!

ing of burning cigarettes on the fixtures. Both the new basins and sinks are formed by a combination of blowing, pressing and vacuum drawing. The basins, which are available in four sizes, can be cut or drilled for various types of fittings and are offered with or without overflows to accommodate either manual or automatic faucet-drain systems. These fixtures range in weight from 1¼ lbs. to 7 lbs. and are made in transparent, translucent or opaque Lucite in a wide variety of pastel shades. The new sinks are also available in several models, ranging from the small galley sink which measures 18 x 12 in. and weighs only 2 lbs., to a 24 x 20 in. unit weighing 7 lbs.

Manufacturer: American Plastic Products Inc., 391 Millburn Ave., Millburn, N. J.

PORCELAIN SINK AND CABINET UNIT added to Tracy Customized kitchen line.

Tracy Manufacturing Co. has recently added a new Deluxe Porcelain Sink and Cabinet Unit to its line of all steel cabinets

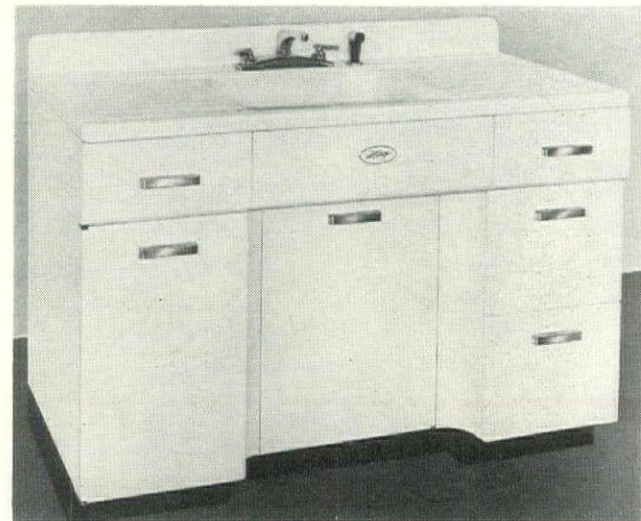

and stainless steel sinks. This unit features a 54 in. double drainboard sink top in white acid-resisting porcelain enamel with cup strainer, streamlined faucet and spray attachment, plus a new Tracy steel undersink cabinet. The cabinet has a recessed center section, insulated doors and drawers, stainless steel handles and concealed ventilation, is finished in baked-on enamel. Supplied with fittings, the complete sink unit retails for about \$149.50 in the East, slightly higher in the West. Matching steel base, wall, broom and linen cabinets are also available.

Manufacturer: Tracy Manufacturing Co., 3125 Preble Ave., Pittsburgh 12, Pa.

PLASTIC COATED WINDOW SHADES are fire resistant, washable, sunproof and waterproof.

Fire-resistant window shades are one of the latest developments in safety for the home. Made from Vinylite resin-coated material, these shades show practically no damage when subjected to a dual jet flame test, while conventional pyroxylin shades are virtually consumed by flames in 37 seconds. The new plastic coated shades are washable, sun and waterproof, are available for use in homes, schools, hotels and public buildings.

Manufacturer: Stewart Hartshorn Co., 250 Fifth Ave., New York 1, N. Y. (Technical Literature, page 148)

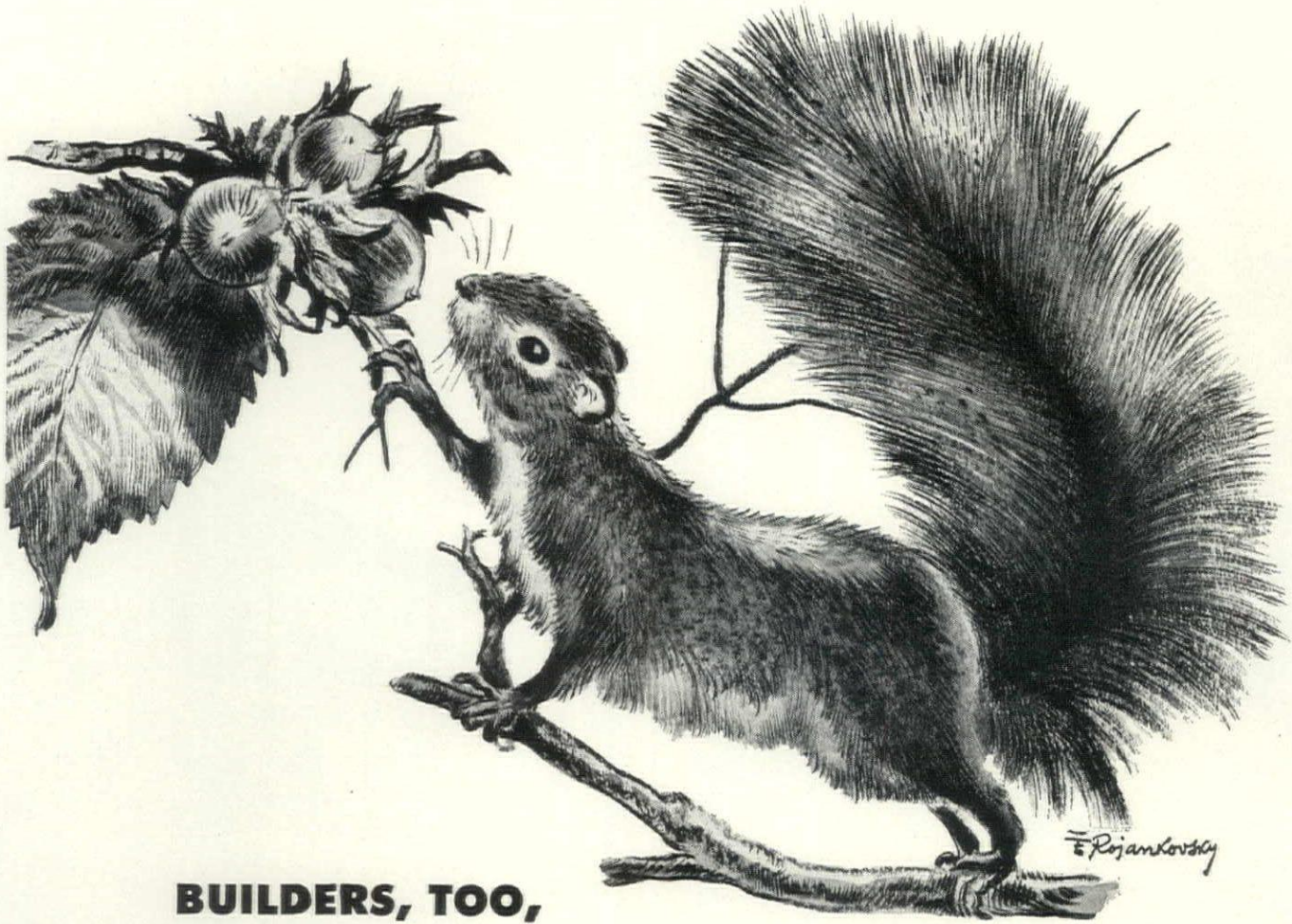

BUILDERS, TOO,

must

PLAN FOR THE FUTURE



Electric Range Section
NATIONAL ELECTRICAL MANUFACTURERS ASSOCIATION
155 E. 44th Street, New York 17, N. Y.

ADMIRAL • CROSLEY • ESTATE HEATROLA • FRIGIDAIRE
GENERAL ELECTRIC • GIBSON • HOTPOINT • KELVINATOR
LEDO • MONARCH • NORGE • QUALITY • UNIVERSAL
WESTINGHOUSE

It's easy to keep your customers happy now, and avoid complaints in the future. Simply give them what they want—and today the trend is to Electric Ranges. Another million American families switched to Electric Cooking last year. Conservative estimates indicate that this year at least a million more Electric ranges will be installed.

This is a definite trend that cannot be ignored. Progressive builders recognize this trend. Electricity is a "must" in any house, and it's simple and economical to include wiring for an Electric Range leading to a range outlet in the kitchen at the time of construction. This is assurance that the houses you build are not only modern today, but will stay modern for years to come!

*Follow
the trend...*

WIRE YOUR HOUSES
FOR ELECTRIC RANGES

Another 1,000,000 American families switched to Electric Cooking last year

SYMBOL OF ADEQUATE WIRING





DEAN MILK COMPANY, HUNTLEY, ILLINOIS.
 ARCHITECT: VICTOR L. CHARN, CHICAGO. CONTRACTORS: RAGNAR-BENSON, INC., CHICAGO.

Grade "A" daylighting: Continuous Insulux Glass Block panels bring excellent daylighting to interior of this modern creamery. Insulux reduces infiltration of dust and dirt, helps maintain high sanitation standards. Window inserts furnish necessary ventilation.

For details consult GLASS section of Sweet's Architectural Catalog or write Dept. E-19, American Structural Products Company, P. O. Box 1035, Toledo 1, Ohio.

American Structural Products Company is a wholly owned subsidiary of the Owens-Illinois Glass Company. It has taken over the manufacture and sale of Insulux Glass Block and other Owens-Illinois structural products.

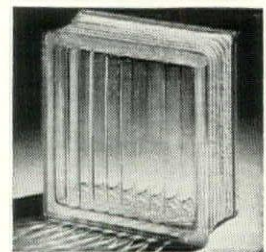

INSULUX
GLASS BLOCK

AMERICAN STRUCTURAL PRODUCTS COMPANY

Subsidiary of

OWENS-ILLINOIS GLASS COMPANY

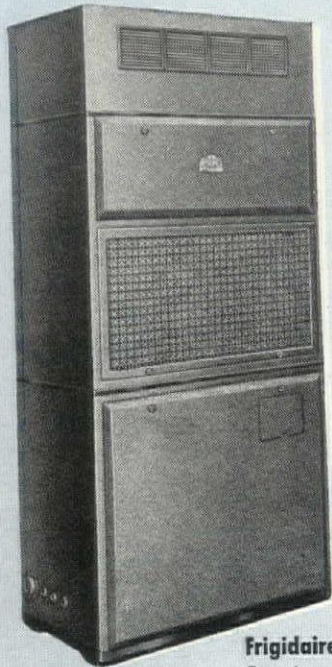

Frigidaire Store Air Conditioners
Complete system in one compact unit.

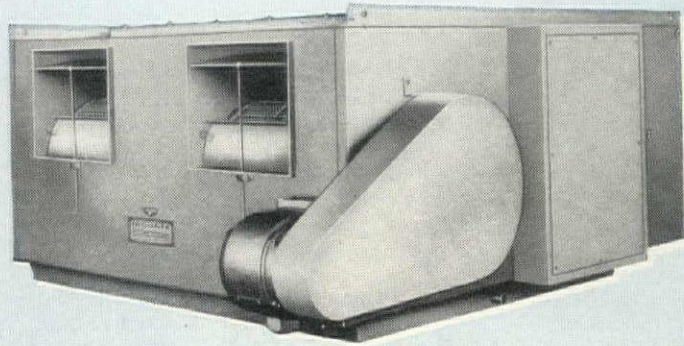

Frigidaire Central System Air Conditioners
Capacities, sizes and types to fit most any need.

Frigidaire Room Air Conditioners
Easily installed. Simple plug-in connection.



3 "PLUS" advantages make the difference in FRIGIDAIRE AIR CONDITIONING

"PLUS"
NO. 1

Right amount of air conditioning for the job . . . no money wasted on too much or too little capacity. For Frigidaire offers a full selection of equipment types and sizes.

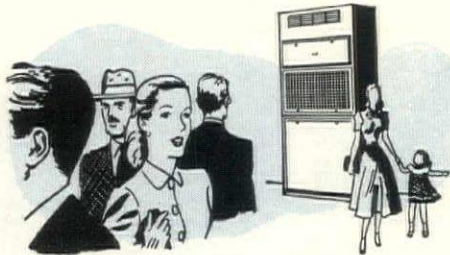

Frigidaire Store Air Conditioners
Cool, dehumidify, filter, circulate, ventilate in summer; heating coil may be added for winter.

Compact, quiet, attractive—may be installed in space to be air conditioned. Installed in multiple for large areas, can be used with a simple duct system.

Ideal for leased premises; require no extensive building alterations, easily moved.

Frigidaire Central System Air Conditioners
There are Frigidaire units in capacities, types and sizes for almost every need. These can be combined in many ways to answer almost any air conditioning problem. Cool, filter, ventilate, circulate and dehumidify in summer; heating coils can be added for winter.

For products you can depend on . . . a name you can depend on . . . a dealer you can depend on—*Call in Frigidaire!* Find Frigidaire Dealer's name in Classified Phone Directory, or write Frigidaire Division, General Motors Corp., Dayton 1, Ohio. (In Canada, Leaside 12, Ont.)

Frigidaire Room Air Conditioners

Cool, dehumidify, circulate, filter, ventilate. Window-type conditioner is easily installed. Powered by the Frigidaire Meter-Miser, simplest cold-making mechanism ever built, backed by a special 5-year warranty. Frigidaire's new floor-type room air conditioner with remote compressor offers larger capacity for offices or homes. In multiple installations provides individual control of each air conditioned area.

"PLUS"
NO. 2

Low operation costs, more years of trouble-free service. For Frigidaire Air Conditioning, like Frigidaire Refrigeration, is a product of the finest in engineering and quality manufacture. Example: Frigidaire compressors, cooling units and controls are *precision-built*—matched to work together on a minimum of current, with a minimum of wear.

"PLUS"
NO. 3

Finest installation and service. For Frigidaire's corps of dependable engineering dealers are factory-trained, know how to get the most out of Frigidaire equipment.

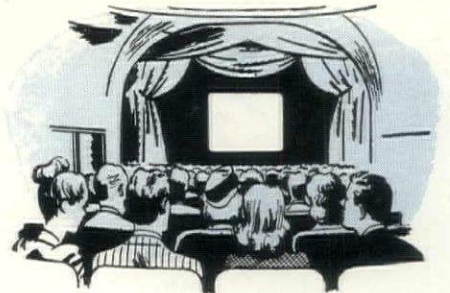

Next time you specify air conditioning, make sure of these three important "plus" advantages . . .

by specifying Frigidaire!

You're twice as sure with two great names



FRIGIDAIRE made only by **GENERAL MOTORS**

Meter-Miser and Reciprocating Type Compressors • Cooling Units • Control Valves • Display Cases • Reach-in Refrigerators • Beverage, Water & Milk Coolers • Ice Cream Cabinets • Home and Farm Freezers • Electrical Appliances for the Home

TECHNICAL LITERATURE

COPPER. Modern Applications of Sheet Copper in Building Construction. Copper & Brass Research Assoc., 420 Lexington Ave., New York 17, N. Y. 144 pp. 8½ x 11 in. Price \$3.00.

Those familiar with the Copper & Brass Research Association's old *Sheet Copper Handbook* will find this, their latest publication, improved in content by the addition of several new features. New users will welcome the precise, direct presentation of technical data, the excellent detail plates, wealth of information and design material. Titled *Modern Applications of Sheet Copper in Building Construction* this volume is based on the practical application of recent intensive laboratory and field research into the behavior of sheet copper under thermal stresses. In general this research indicates the use of cold rolled (cornice temper) instead of soft (roofing temper) copper because of its greater strength; the use of heavier, thicker sheets, 20-oz. minimum, instead of 16-oz. (except in a few instances); and new principles for designing copper linings for built-in gutters, the weight of sheet being directly related to length, width, depth and side angles. Features of the new work that should appeal especially to the architect are: design data for gutters, leaders, valleys, expansion joints; table of recommended weights and tempers; tables of stock sizes of sheet and strip; dead-level roofs; roof cooling; roof gardens and pools; the use of factory made roofing accessories; and a specification covering all types of roofing and flashing so arranged that individual clauses and alternate methods can be chosen quickly.

LIGHTING. Spero Electrical Products. The Spero Electric Corp., 18222 Lanken Ave., Cleveland 19, Ohio. 42 pp. 8½ x 11 in.

Giving detailed catalog and technical data on all of Spero's

five lines of electrical products—fluorescent luminaires, reflectors, flood lights, vapor proof units, materials for electric construction—this booklet contains useful information for those interested in practical lighting. The contents include such data as candlepower distribution, coefficients of utilization, foot candle level charts, specifications, dimensions, etc. for all important fluorescent fixtures. In addition, it contains illustrations of the numerous types of fluorescent luminaires and other lighting products, installation photographs, dimensional sketches, mounting diagrams, etc.

BASEMENTLESS CONSTRUCTION. Concrete Floors for Basementless Houses. Circular Series F 4.3. Small Homes Council, Mumford House, University of Illinois, Urbana, Ill. 4 pp. 8½ x 11 in.

Some important recommendations on how to build a warm, dry concrete floor for a basementless house are set forth in this brochure. Featuring the results of research conducted by the University of Illinois on nine different types of floor slabs, the work discusses such subjects as how to build a good concrete floor, drainage, fill, vapor barrier, insulation, curing for cold floors, floors with panel heat and estimating heat loss. For a warm, dry concrete floor the brochure recommends good drainage with a 4-in. fill of coarse washed gravel or crushed rock under the floor slab; a vapor barrier, consisting of a ½ in. rigid asphalt board or reinforced duplex paper with asphalt center, over a fill and extending to the outside edge of the floor; and at least 2 in. of rigid waterproof insulation along the exposed edge of the floor and extending 2 ft under it.

(Continued on page 150)

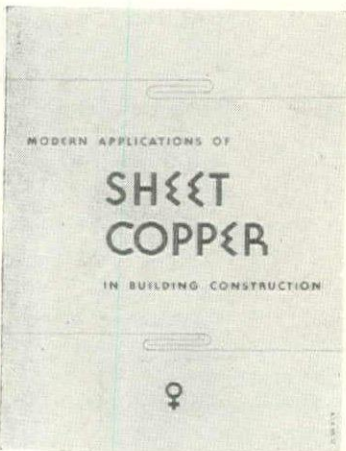

CORK is
WARM,
CORK is

Buoyant

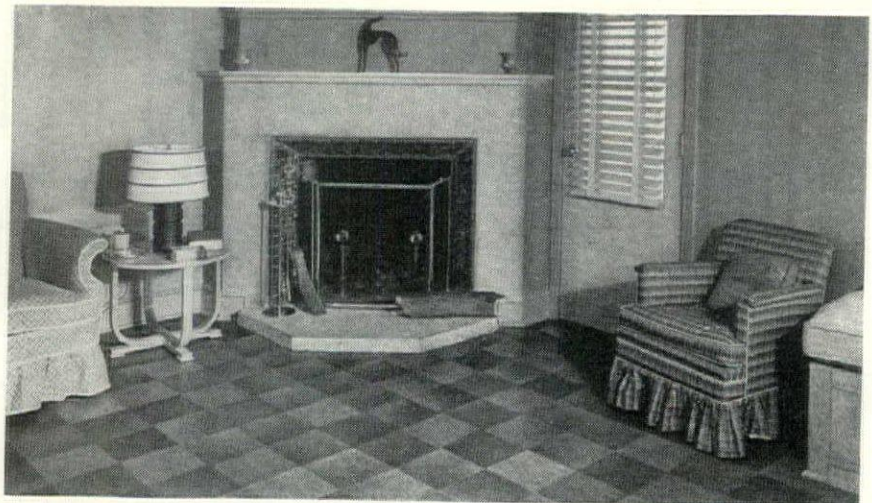

There's nothing underfoot like Corinco Cork Flooring. It's warm to walk on, warm to look at. It keeps its resilience for years. It's quiet. It's easy to install on old and new construction, on metal, concrete or wood. It's so easy to maintain that a dry mop does the trick. Any wonder that so many progressive architects and contractors recommend Corinco Cork Flooring for homes, offices, churches, schools and public buildings of all kinds? Write our engineering office for specifications, details and layouts.

CORK INSULATION CO., INC., 155 EAST 44th ST., NEW YORK
Gentlemen: Please mail me more information about
 Cork Tile Flooring Cork Stair-Treads

Name _____
Street _____
City _____ State _____



CORK INSULATION CO., INC.

155 EAST 44th STREET, NEW YORK 17, N.Y.

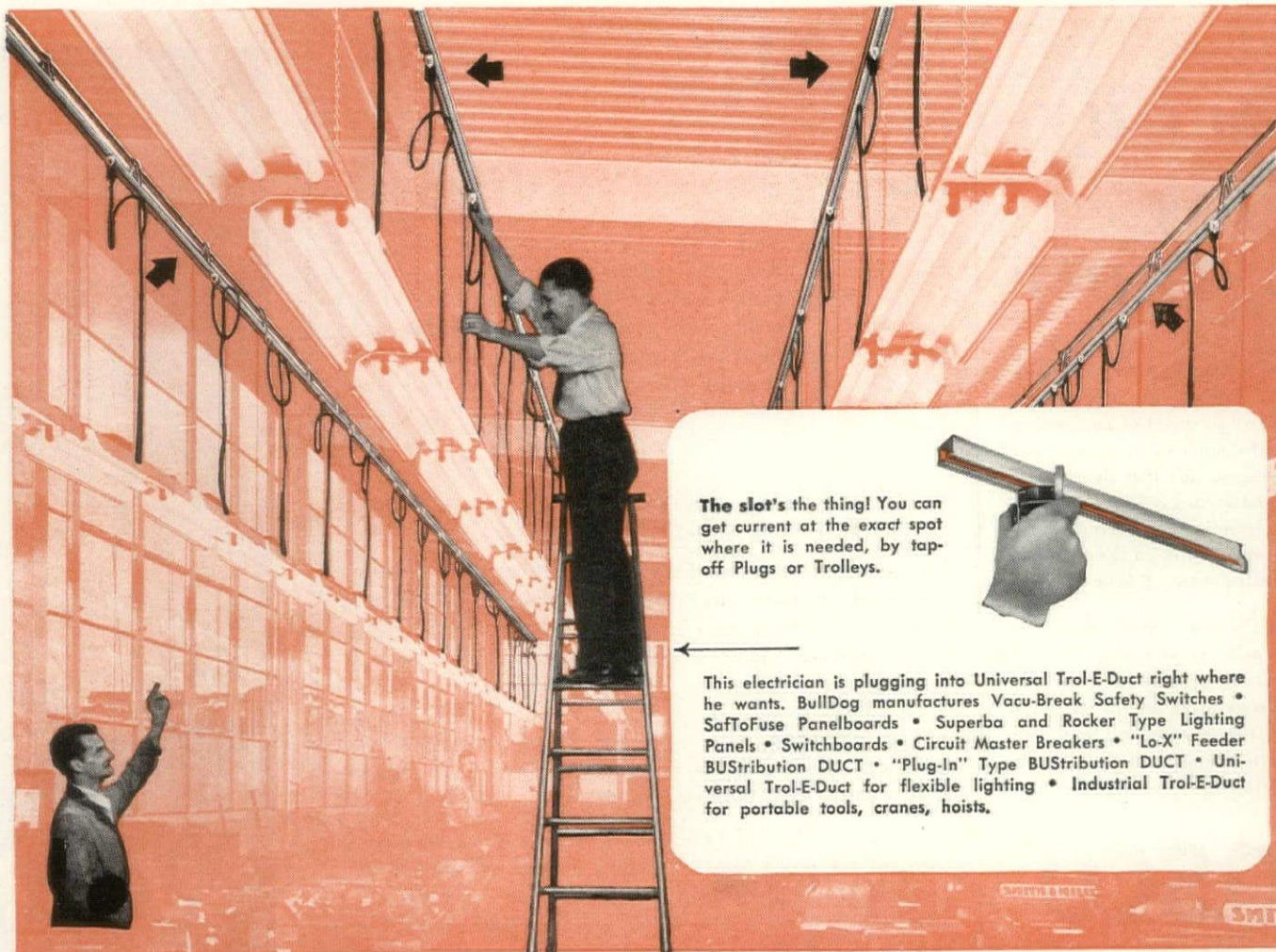

The slot's the thing! You can get current at the exact spot where it is needed, by tap-off Plugs or Trolleys.

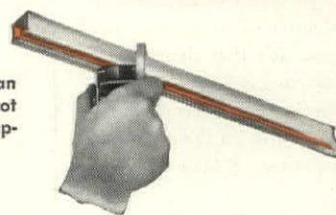

This electrician is plugging into Universal Trol-E-Duct right where he wants. Bulldog manufactures Vacu-Break Safety Switches • SafToFuse Panelboards • Superba and Rocker Type Lighting Panels • Switchboards • Circuit Master Breakers • "Lo-X" Feeder BUStrihution DUCT • "Plug-In" Type BUStrihution DUCT • Universal Trol-E-Duct for flexible lighting • Industrial Trol-E-Duct for portable tools, cranes, hoists.

Why should lighting systems be light-fingered?

IN MANY WAYS, old-style lighting systems take money right out of your clients' pockets.

They start picking pockets whenever fixtures have to be moved. First, there's the cost of the rewiring job. Then there's the cost of the production shut-down when current is cut off to tap in. Finally, there's the cost of the materials scrapped.

And what if your client decides to save by making the old lighting layout suffice? Even then he loses profit dollars through reduced production due to inadequate lighting.

The solution

Do away with these losses; specify Bulldog Universal Trol-E-Duct! This modern electrical system provides current, when it's wanted, exactly where it's wanted.

Bulldog Universal Trol-E-Duct is completely flexible. It serves lighting fixtures of any type, and small portable tools as well. At any point along its continuously slotted duct, twist-out plugs or trolleys can tap off power from the enclosed bus bars. It's safe . . . simple . . . quick!

All parts salvable

Whenever a major change in plant layout takes

place, Bulldog Universal Trol-E-Duct can be taken down and reinstalled in a short time, with no loss of parts. All material can be re-used.

Ask your Bulldog Field Engineer to show you a Universal Trol-E-Duct installation nearby. Or, write Bulldog direct for descriptive folders.

Bulldog's Field Engineers welcome the opportunity to sit in on the planning stages of a building project. Their knowledge of electrical distribution layout can mean savings in installation and maintenance costs, as well as highest efficiency and reliability in actual operation. Why not take advantage of this pre-planning service?

BULLDOG ELECTRIC PRODUCTS COMPANY
DETROIT 32, MICHIGAN • FIELD OFFICES IN ALL PRINCIPAL CITIES
IN CANADA: BULLDOG ELECTRIC PRODUCTS OF CANADA, LTD., TORONTO

BULLDOG



HEADQUARTERS FOR ELECTRICAL DISTRIBUTION

TECHNICAL LITERATURE

Costs Less to Buy- Costs Less to Apply

Wasco Copper Fabric Flashing not only saves dollars in initial cost, but it saves many more dollars in speed of application. It is easily hand-shaped to fit around corners and odd shapes. It's that flexible! It saves time and labor in cutting, and eliminates waste because it is delivered to the job cut to exact size. With all these savings you get *all the advantages of heavy copper.*

Wasco is a full sheet of copper bonded to and between two layers of asphalt impregnated fabric. The copper forms a permanent barrier to water and vapor. Its rough textured fabric forms a perfect and permanent bond with mortar and protects the copper from electrolysis.

wasco COPPER FABRIC FLASHING

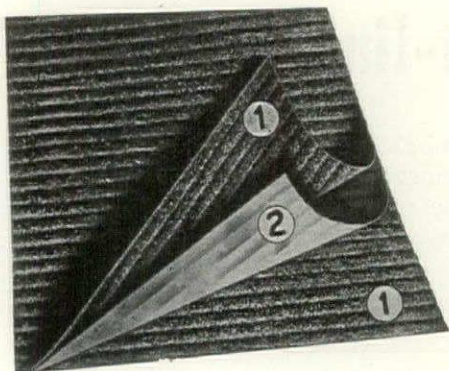

1. Asphalt Impregnated Fabric
2. Copper Sheetting

OTHER WASCO PRODUCTS

COPPERSEAL: Economical all-purpose flashing. Pure electro-sheet copper coated on both sides with tough bituminous composition.

COP-R-TEX: For residential work. Pure electro-sheet copper backed with reinforced waterproof Kraft paper.

See Sweet's 3 d-6. Write for File Folder, "Improved Method of Handling Turn-up", and Sample.

WASCO Flashing Company
86 Broadway, Cambridge 42, Mass.

CONCRETE HARDENER. Wearproof and Dustproof Concrete Floors with Lapidolith. Building Products Division, L. Sonneborn Sons, Inc., 88 Lexington Ave., New York 16, N. Y. 6 pp. 8½ x 11 in.

This folder tells how concrete and terrazzo floors may be insured against wear, deterioration and dusting by surface-treating with Lapidolith, Sonneborn's patented liquid concrete hardener. Text and cross-section drawings illustrate how Lapidolith penetrates into the concrete to produce a close-grained, granite-hard, vitreous topping that stands up under heavy traffic, prevents the formation of concrete dust, and protects floors against the deteriorating effects of many industrial oils and chemicals. Other sections include application data and several views of typical industrial floors treated with Lapidolith.

WINDOWS. Residence Steel Casements. Detroit Steel Products Co., 2250 East Grand Blvd., Detroit, Mich. 12 pp. 8½ x 11 in.

Fenestra Residence Steel Casements, steel basement windows and utility windows are illustrated and described in this catalog. Detail drawings of various installations and complete specifications adequately cover those types and sizes available in the eastern territory.

SPACE HEATERS. How To Make The Yardstick Zone The Comfort Zone. Catalog No. 12. The Coleman Co., Inc., Second & St. Francis Ave., Wichita, Kan. 24 pp. 8¾ x 10 13/16 in.

The complete line of Coleman oil-burning space heaters is featured in Catalog No. 12. Opening sections explain how the Coleman heater places heat in the *Yardstick Zone*: the 3 ft. above the floor where one works, plays and lives. Following sections then elaborate upon the advantages of Coleman units and the various types of heaters in the line.

VALVES. Cash-Acme Catalog D-14. A. W. Cash Valve Manufacturing Corp., 666 E. Wabash Ave., Decatur, Ill. 31 pp. 8½ x 10 13/16 in.

This 1948 catalog gives complete data on Cash-Acme pressure reducing and regulating valves for use with steam, air, gases, water, oil and other liquids on numerous pieces of equipment. A few of the valve types for which data are included are: by-pass, domestic, industrial, vacuum relief, pressure reducing and regulating, refrigeration, and both diaphragm and pop type pressure relief valves. Other sections of the booklet cover pressure controls for hot water heating systems, strainers and instructions for installation and piping of pressure reducing and regulating valves. A complete description of each item is included along with technical data, capacities, installation suggestions, dimensions, price, etc.

ELECTRONIC AIR FILTER. Electro PL Model B. Bulletin No. 257. American Air Filter Co., Inc., 215 Central Ave., Louisville 8, Ky. 12 pp. 8½ x 11 in.

Electro-PL, American Air Filter's new electronic air filter, with an intermediate cleaning efficiency for applications where the efficiency of a mechanical filter is too low and that of an electronic precipitator is unnecessarily high, is described in this bulletin. Opening pages illustrate and discuss the various parts of the new dry-type electronic air filter, power packs for installation, voltage requirements and design features of the unit. Other sections feature the unit's advantages, specifications, performance characteristics and installation data.

(Continued on page 152)

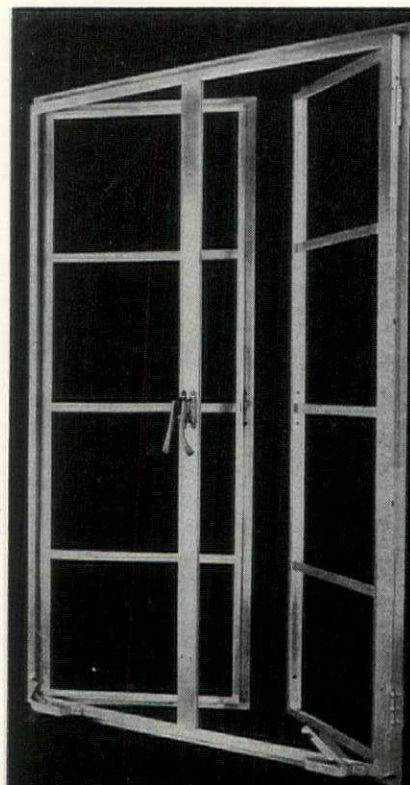

casement type

ware aluminum windows

heavier sections • light weight
yet rigid • storm tight • easily
operated • need no painting.

write for catalog and prices

ware laboratories, inc.
3700 n. w. 25th St., miami 35, fla.

general sales office
21 west street, new york 6, n. y.
telephone: whitehall 3-6860

Air Infiltration Tests on Ware Aluminum Windows

Static Press. (in water)	Equip. Wind Velocity (m.p.h.)	Infiltration cu. ft./min. ft. per.
.30	25	None
.78	40	None
.98	45	0.18
1.33	52	0.50
1.50	55	0.65
1.66	59	0.76

Details of the results of the
above test, made by New
York Testing Laboratories,
Inc. will be gladly mailed
to anyone interested.

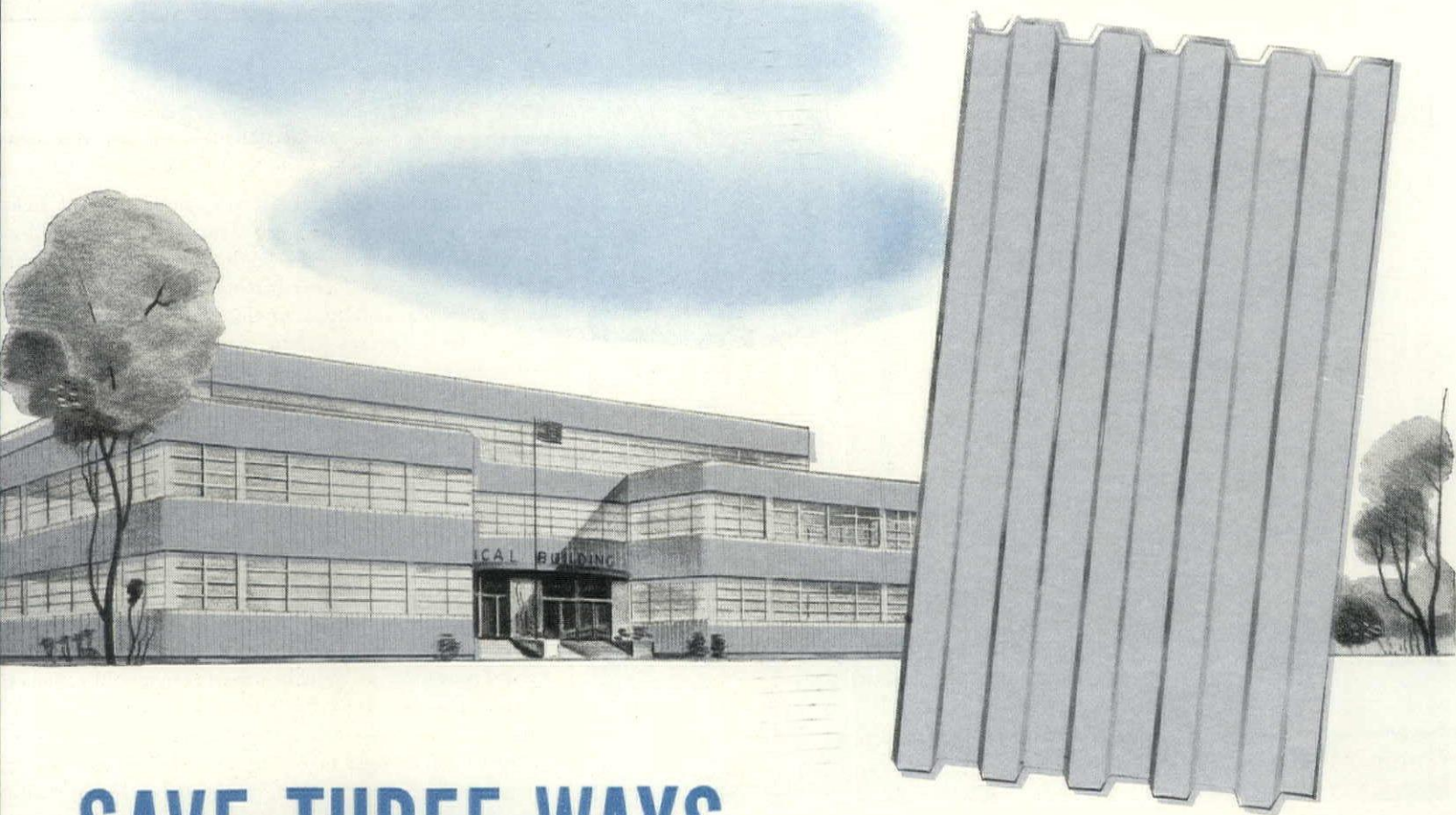

SAVE THREE WAYS

on Exterior Wall Panels with Alcoa Economy Castings

LOW FIRST COST

You save right from the start with Alcoa Economy Castings for Spandrels and Wall Panels. By co-ordinating specifications and production facilities, Alcoa can now offer castings at economy prices.

FAST CONSTRUCTION

Large, light Alcoa sections go up fast—saving both handling and erection costs. And castings may be delivered to the job complete with anchor holes. This means simplified installation . . . saves construction time and money.

LESS MAINTENANCE

Lower maintenance costs result naturally from

the use of Alcoa Aluminum. Aluminum resists corrosion . . . produces no colored compounds to rust-streak adjoining surfaces . . . and requires no painting.

Send for Free Booklet

Send for the free booklet, "Alcoa Economy Castings". You'll find it a valuable reference with information on typical details . . . methods of anchoring . . . expansion and contraction . . . heat transmission . . . shrinkage . . . as well as recommendations for the writing of specifications.

Call your nearby Alcoa sales office or write ALUMINUM COMPANY OF AMERICA, 1866 Gulf Building, Pittsburgh 19, Pennsylvania.

ALCOA FIRST IN ALUMINUM

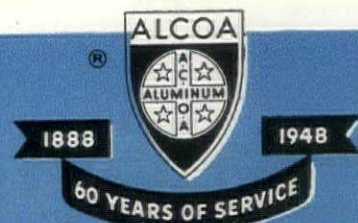

Your **DOUBLE DEFENSE** against electrical delay



How to keep up to the minute on electrical "widgets"

Improvements in electrical wiring materials may be individually *minor* — but they add up to produce *major* economies. It would take days and days for you to keep up to the minute on all the "widgets" coming on the market.

But there's no need to be a detail hound. Through your electrical contractor—or from Graybar direct if desirable—you can get facts on the *genuine* advances, without wasting time on also-rans.

Graybar is an all-inclusive source of electrical product information—for your kind of commercial, industrial, or residential building. Our *specialists* on product application can help you and the electrical contractors you work with, to apply new ideas to any wiring, lighting, ventilating, communicating, or other electrical problem.

Directly or indirectly, you benefit from electrical buying "via Graybar." Both *as* you plan and *after*, you'll find it's good to have Graybar in the picture. 4890

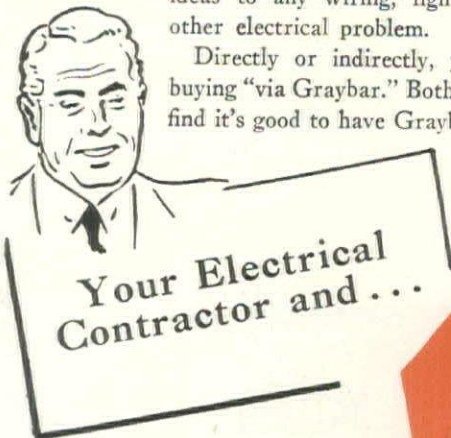

Graybar Electric Company
Executive offices:
Graybar Building, New York 17

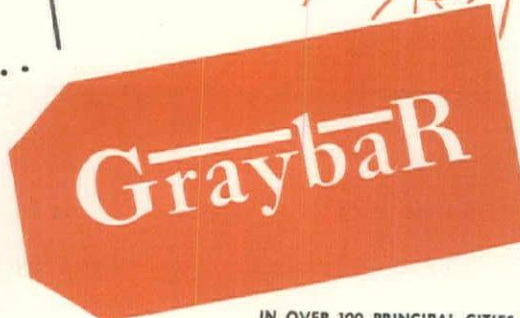

IN OVER 100 PRINCIPAL CITIES

ROOF TRUSSES. Clear Span Teco Trussed Rafters in Modern Home Planning. Timber Engineering Co., 1319 18th N.W., Washington, D. C. 8 pp. 8½ x 10⅞ in.

Prepared especially for designers, builders, and financial institutions, *Clear Span Teco Trussed Rafters in Modern Home Planning* features the fabrication, erection and particularly the economies of Teco trussed rafters for residential use. After a graphic coverage of the features, construction uses of Teco Trussed rafters, two series of typical truss rafter designs are briefly noted. One of the two series is dry wall construction, the other for wet wall construction. Both design series are for spans ranging from 20 to 32 ft. roof slopes of 4 in., 5 in., 6 in. and 7 in. Closing pages illustrate how clear span trussed rafters offer unrestricted interior space without limiting the roof design.

ACOUSTICAL MATERIAL. Johns-Manville Fibretone. Johns-Manville, 22 East 40th St., New York 16, N. Y. 8 pp. 8½ x 11 in.

Fibretone, the Quiet Ceiling With One Hundred Thousand Noise Traps is Johns-Manville's most recent publication on control of sound. Describing what Fibretone is, the book tells how this low-cost acoustical material quiets noise wherever it can be used to advantage. The work also features design possibilities, erection details and a list of Fibretone sizes, weights, and sound absorption data.

REQUESTS FOR LITERATURE

HANK AVERY, INC., architects, 801 Mc. Burnett Bldg., San Antonio, Tex.

G. R. BEAULAND, architectural student, 71 Savile Road, Methley, Leeds, England.

JOSEPH COLOMBO, architectural student, 1103 So. Ford Blvd., Los Angeles, Calif.

LEONARD HEIFERLING, architectural student, 960 Ave. St. John, New York 55, N. Y.

HERMAN FINGER, designer, 231 Brightwater Court, Brooklyn, N. Y.

JOSEPH GREER, JR., architectural student, 1640 Interlaken Pl., Seattle 2, Wash.

JOHN S. GIFFORD, architect, 805 Palace Hdwe. Bldg., Erie, Pa.

GEORGE KIRKPATRICK, architectural student, 5272 Townsend Ave., Los Angeles 41, Calif.

CARLOS LAZO, architect, Tabasco 198, Mexico, D.F.

ROBERT EUGENE MURRAY, architect, 501 West 121st St., New York 27, N. Y.

GERALD P. NODES, architect, 27 West Ave., Worthing, Sussex, England.

ROBERT L. PRIMM, 4702 Commonwealth, La Canada, Calif.

L. F. RICHARDS, architect, 411 Lafayette St., Santa Clara, Calif.

ROBERTS & SHIER, LTD., civil engineers, 1283 Lennon Way, San Jose 10, Calif.

R. W. SORENSEN, structural architectural engineer, 1440 South 10th East, Salt Lake City, Utah.

GEORGE C. STATEN, JR., architectural student, 919 E. College Ave., El Paso, Tex.

(Continued on page 156)

—still another **Koppers Roof**
passes the 20-year mark

...without costing the owner a cent for repairs!



The Gibson School, Birmingham, Ala. Its Koppers Bonded Roof was completed on April 3, 1928. Owner: The Board of Education, Birmingham. Roofer: George F. Wheelock Co. General Contractor: M. C. Banks Co. Architect: Warren, Knight & Davis.

THIS time it's the Gibson School in Birmingham, Alabama, whose Koppers Bonded Roof has passed its 20th birthday. And this Koppers Roof — which was Bonded* against repair costs in 1928 — is good for many more years of service . . . the photograph shows that.

Back in 1928, Koppers claimed that their Pitch and Felt Roofs would last for 20 years. That's when Koppers first told owners that Koppers Roofs could be Bonded, and backed up that announcement with Koppers Roof Guarantee Bonds — Bonds which indemnify owners against the cost of roofing repairs for 10, 15 or 20

years according to the type of roof applied. The imposing records being established by Koppers Bonded Roofs show that Koppers was extremely conservative in its predictions.

Koppers Case Histories prove that Koppers Coal Tar Pitch and Tarred Felt make an unbeatable combination. It will pay you to learn all the advantages of using Koppers Roofing Materials. Write for full information.

*Koppers issues Roof Guarantee Bonds in such sections of the United States as are covered by its inspection service.

KOPPERS COMPANY, INC. • Pittsburgh 19, Pa.



SPECIFY KOPPERS FOR LONG-LIFE ROOFING

*Thirty brilliant seconds
are not enough*

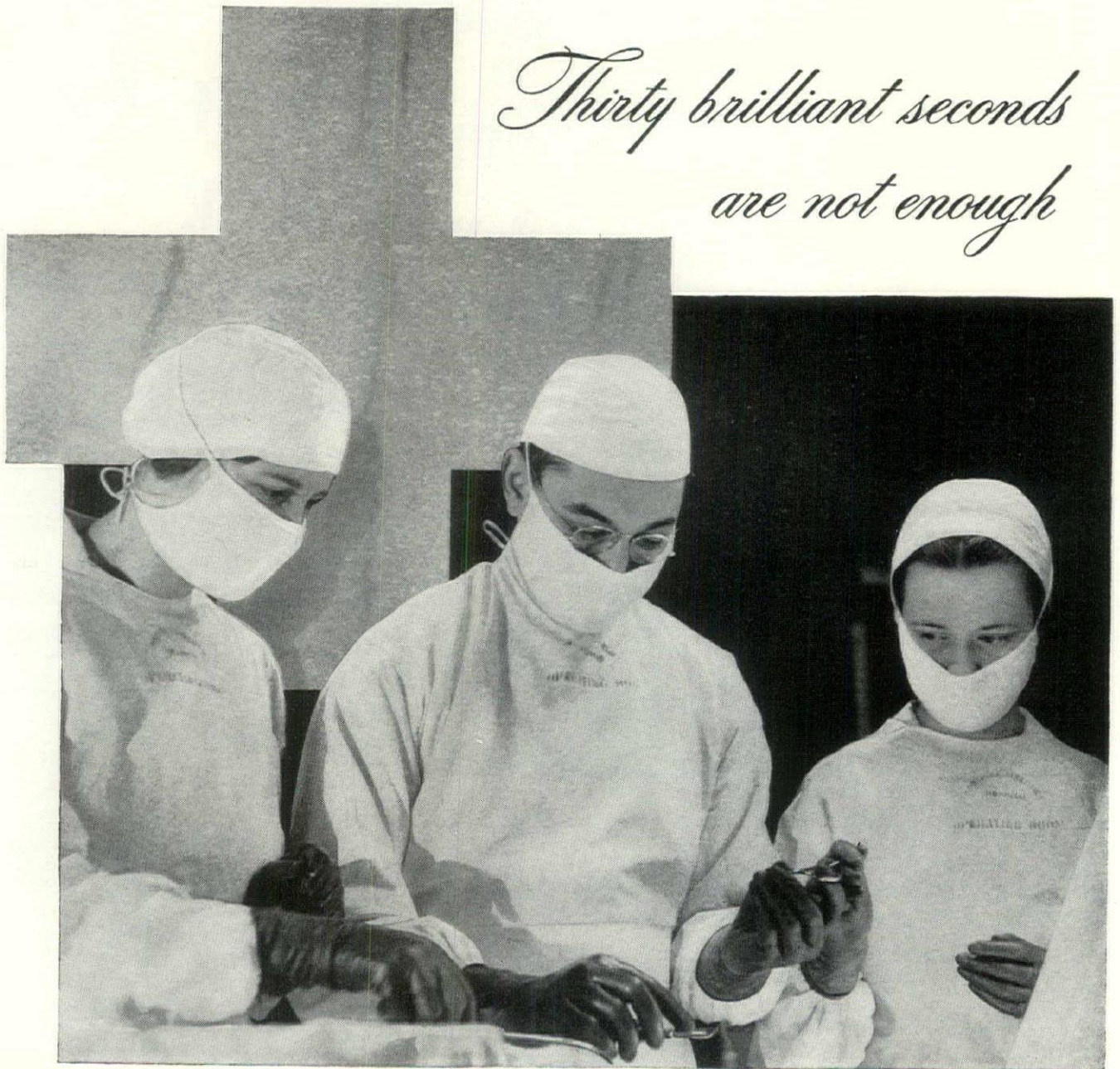

A human life

often hangs upon a few seconds of skillful surgical action.
But other factors are equally important.

Hygiene is one of these factors —
an absolute necessity for surgical success.

Marble is a hygienically perfect surface.

It will not harbor germs nor foster unpleasant odors.

It needs only the simplest attention to maintain or clean.

*Information about Marble
and Marble Service
will be given promptly by the
Marble Institute's Managing Director
Romer Shawhan, R. A.*



**Marble Institute
of America, inc.**

108 FORSTER AVENUE, MOUNT VERNON, N. Y.

FIRST

in heating and plumbing
because they're the best
for both important jobs!



The attractive little playroom is a good example of the practical use you can make of a small basement when your heating unit is both good looking and compact. The **MOHAWK** Winter Air Conditioner shown here lends a distinctive, pleasing decorative note to this basement setting, while providing clean, dependable heat to the entire house. Famous for its beauty, sound engineering features and sturdy construction, the Mohawk burns natural, manufactured, mixed or liquefied petroleum gas with maximum efficiency and economy.

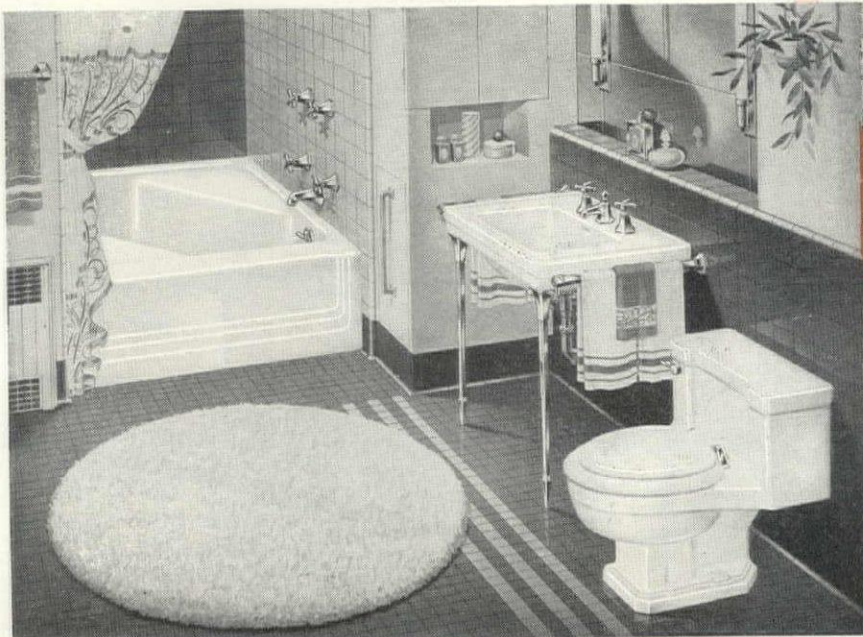

You achieve the ultimate in bathroom luxury when you choose the **NEO-ANGLE** bath and harmonizing fixtures from the American-Standard line. The bath, occupying space only about four feet square, is the recessed model of the Neo-Angle with its two integral seats and wider, flatter bottom; the lavatory is the graceful **ROXBURY** with large square bowl, tapered legs, and convenient towel bars. Fittings and other exposed metal finished in gleaming, non-tarnishing Chromard. The water closet is the **MASTER ONE-PIECE**, with quiet, thorough syphon vortex water action.

■ As the world's largest manufacturer of heating equipment and plumbing fixtures, American-Standard is your most dependable source for both. Not only does American-Standard give you the widest choice of styles, types, models and sizes, but it also is your assurance of the finest quality in *both* heating equipment and plumbing fixtures. That's why more American homes have heating and plumbing by American-Standard than by any other single company. Yes, you'll find that it pays to "make it American-Standard all the way"! For detailed information about the complete range of products, contact your Heating and Plumbing Contractor. **American Radiator & Standard Sanitary Corporation**, P. O. Box 1226, Pittsburgh 30, Pa.



AMERICAN-Standard
First in Heating and Plumbing

Serving home and industry

AMERICAN-STANDARD • AMERICAN BLOWER • CHURCH SEATS • DETROIT LUBRICATOR • KEWANEE BOILER • ROSS HEATER • TONAWANDA IRON

TECHNICAL LITERATURE

Specify
MONARCH
INSTANT
EXIT
PANIC
DEVICES



FULL DETAILS
IN SWEET'S
CATALOG

Write For Literature



CLAYTON & LAMBERT MFG. CO.

1709 DIXIE HIGHWAY • LOUISVILLE 10, KENTUCKY

**WANTED! LONG WEAR
AT LOW COST...**



"So they MASTIPAVED the FLOOR"

For 24 years Pabco Mastipave has solved the world's toughest floor-problems. Hundreds of millions of square feet in use in buildings, factories, hospitals, institutions, schools, stores, warehouses, etc.! Write us for "no obligation" survey of your floor-problems.

**PABCO
MASTIPAVE**

America's No. 1 Long Life, Low Cost Floor Covering

THE PARAFFINE COMPANIES, INC.

New York 16 Chicago 54 San Francisco 19



REQUESTS FOR INFORMATION

LOUIS J. ANGELE, landscape architect, 1441 68th Ave., Oakland, Calif., desires literature on residential landscaping.

ARGRAVES & MORT, consulting engineers, 70 College St., New Haven, Conn., request literature on materials and equipment for commercial buildings, industrial plants and municipal works.

WILLIAM J. CLARK, corporate surveyor and town planning consultant, 166 Walsingham Gardens, Ewell, Surrey, England, requests information on scientific research having to do with acoustics, and sound and thermal insulation.

WILSON B. DODSON, Graduate Architectural Teaching Fellow, Virginia Polytechnic Institute, Dept. of Architecture, Blacksburg, Va., desires information on new building materials, construction methods and equipment for thesis.

RICHARD R. GEOFFROY, architectural student, 56 Ave. Clevefont, Richmond, Quebec, Canada, requests information on library design and construction.

E. W. GLENESK, architectural student, 160-A Home St., Winnipeg, Manitoba, Canada, desires information on railroad stations for thesis.

SANDERS & THOMAS INC., consulting engineers, Security Trust Bldg., Pottstown, Pa., requests information on materials and equipment used in residential construction.

PARK L. VERNER, surveyor and designer, 593 Lafayette St., Santa Clara, Calif., desires information on residential and store building materials.

- November 8 to 11, at the Hotel Sherman, Chicago
- Booth No. 16
- Retail Paint & Wallpaper Distributors of America



An Invitation

To you we extend a cordial invitation to visit the Moleta Booth and to view a unique Color Show... a graphic demonstration of the quicker way, the better way to "the right color."

We look forward to greeting you at the MOLETA Booth.

150 beautiful colors are displayed in the MOLETA COLOR GUIDE... each tint shown on a large (9"x15") page. Write for your copy, \$5.00, delivered anywhere in the U. S. A.

MONROE, LEDERER AND TAUSSIG, INC.
606 N. American St., Phila. 23, Pa.

Moletg FLAT OIL PAINT
ARCHITECTURAL *The Truly Washable Paint*



The vertical surfaces of this desk and cabinets are Formica Realwood*...the beauty of natural wood grain with the utility of genuine Beauty-Bonded Formica. The horizontal tops are solid color Cigarette-Proof Formica.



The Story of Joe, the Lazy Janitor who made good

Beauty Bonded
FORMICA
Reg. U. S. Pat. Off.

at Home with People
at Work in Industry



Joe's the clean-up man in these Formica-surfaced offices. The Boss thinks he's a hard worker. Mornings, the offices shine like new. Yet, all Joe does is give the Formica a casual wipe. The Architect who designed these colorful beauties planned for lazy janitors.

At the first conference here, the big guns were a little over-awed by the beauty of their Formica surroundings. Ever since, it's proved to be a real work room. Formica Realwood* on the table, the window ledges, and walls.



Photographs
courtesy of
Bakelite
Corporation

A beauty, isn't it? Don't let the uncluttered desk fool you...that's just for the picture. A lot of work goes on in this office and the Formica* desk and window tables take a beating. The tops are Cigarette-Proof Formica.



Check the Formica Catalog in "Sweets". Write for a supply of "You and Beauty Bonded Formica", a new folder you'll want for your clients. Formica 4631 Spring Grove Ave., Cincinnati 32, Ohio.

*Reg. Trade Names U. S. Pat. Off.
COPYRIGHT 1948 FORMICA, CINTI., OHIO

REVIEWS

PAINTING TOWARD ARCHITECTURE. Text by Henry-Russell Hitchcock. Foreword by Alfred H. Barr, Jr. Duell, Sloan & Pearce, New York. 118 pp. Illus. in full color. 8 x 11. \$6.

As collateral branches on the same family tree, abstract art and modern architecture share a common esthetic genealogy. But that painting has had a direct and immediate impact on architectural design—Henry-Russell Hitchcock's general thesis in his text for this collection of abstractions—is more debatable; enough so that Alfred H. Barr Jr., who furnishes the introduction, is constrained to warn us against exaggerating the relationship. "It (the relationship) was shortlived so far as composition and plan were concerned and not always salutary."

True, abstractions and the modern building have many things in common: lack of ornamentation; simplification; a rectilinear esthetic form. True, too—in Europe during the 1920's—the impingement of art on architecture was at times intimate. Le Corbusier, Oud, Van der Rohe, Gropius were all closely connected with the "modern" movements in their countries. Yet even this was partly a matter of historical confluence rather than interdependence. Modern architecture soon freed itself of the rigid conceptual doctrines of the abstract art of the Twenties.

Yet the two forms are joined in a common revolt, if not always in a common purpose. As Mr. Hitchcock states: "... certain basic assumptions began to be made about the arts which were later to provide the esthetic premises both of abstract painting and of modern architecture . . . One assumption . . . is that the artistic value of a picture or a building resides not in the intrinsic interest of its individual elements but in their physical relationships to one another. Another assumption is that mere lines of stress or areas of plain color, appealing directly to the eye, can be at least as powerfully expressive . . . as more complicated forms whose

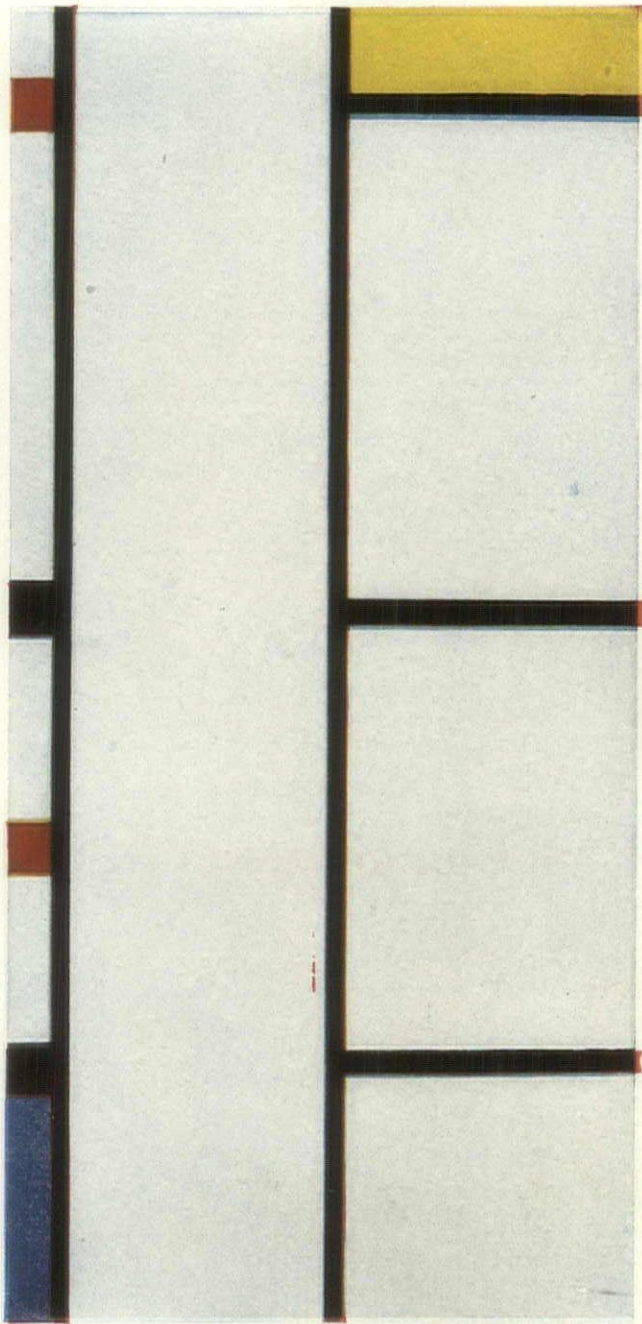

Piet Mondrian
1872 - 1944
Composition
1935 - 42

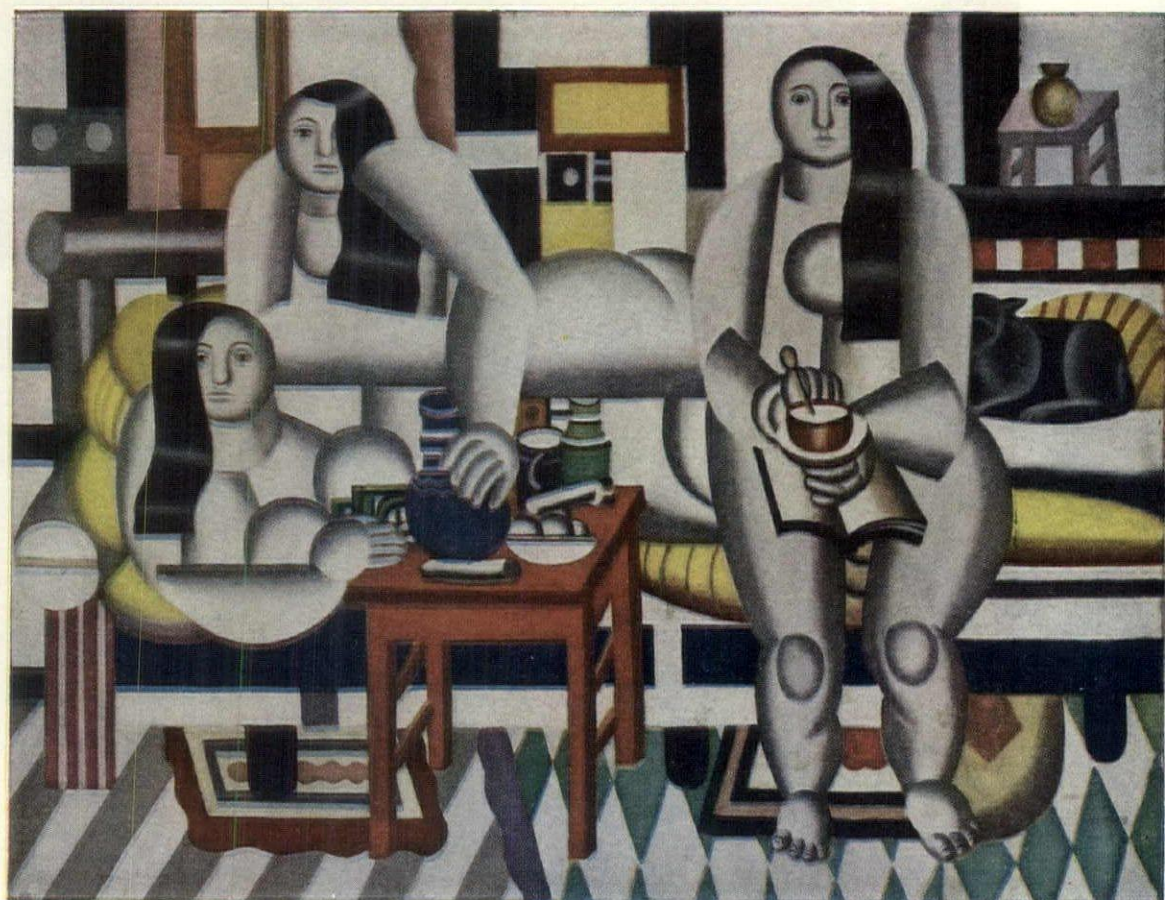

Fernand Léger
1881 -
Petit Dejeuner
C. 1921

representational connotations are apparent and familiar." Abstract painting, Mr. Hitchcock declares, played a major role "in crystallizing the visual character of modern architecture."

Whatever architecture's actual debt to painting, the modern building provides a fitting esthetic climate for the enjoyment of abstract art, which is more at home—housebroken, the French would say—on the wall of a contemporarily designed house than in a Victorian mansion. For example, Joan Miro's biomorphic shapes have been fittingly used to decorate the new Terrace-Plaza Hotel in Cincinnati, but they would scarcely be appropriate to the Plaza in New York.

Yet at best the accommodation of modern architecture to abstract painting is an attenuated link between two parallel and independent activities. More important, perhaps, is the role the abstractionists have played in preparing the public to accept the esthetics of modern buildings. In a sense, it is the client who has been most deeply influenced rather than the architect, who thinks in terms of a three-dimensional medium, and works within the limitations of materials, engineering, and functional utility.

The key to Mr. Hitchcock's text is in the title's connective

word *toward*, which might imply a sense of distance as well as direction. The various excellent examples of abstract art in the Miller Collection are recommended as possible "inspiration pieces" on which the architect can draw in fitting his work into a modern esthetic. The extent to which this is practical is something which can be determined only by the architect himself. While the Miller Co. found that the collection was of great value in jogging the imagination of its own designers and believes that it is likely to have an equally marked effect on the architects who design the modern buildings into which its product—industrial and commercial lighting—is built, it has refused to exploit the advertising value of its enterprise in any way, being much more concerned with the broadly educational aspects of the collection. This 104-year old firm is to be commended for its patronage of a vital art form; through Mrs. Burton Tremaine, wife of the president, the whole program has been intelligently and, from a commercial point of view, unostentatiously made available to public appreciation. Mr. Hitchcock, for his part, has contributed much to our understanding of modern art and modern architecture by staking out the areas in which they have most to offer one another. D.D.

Le Corbusier
(Charles - Edouard Jeanneret)
1887 -
Still-Life
1925

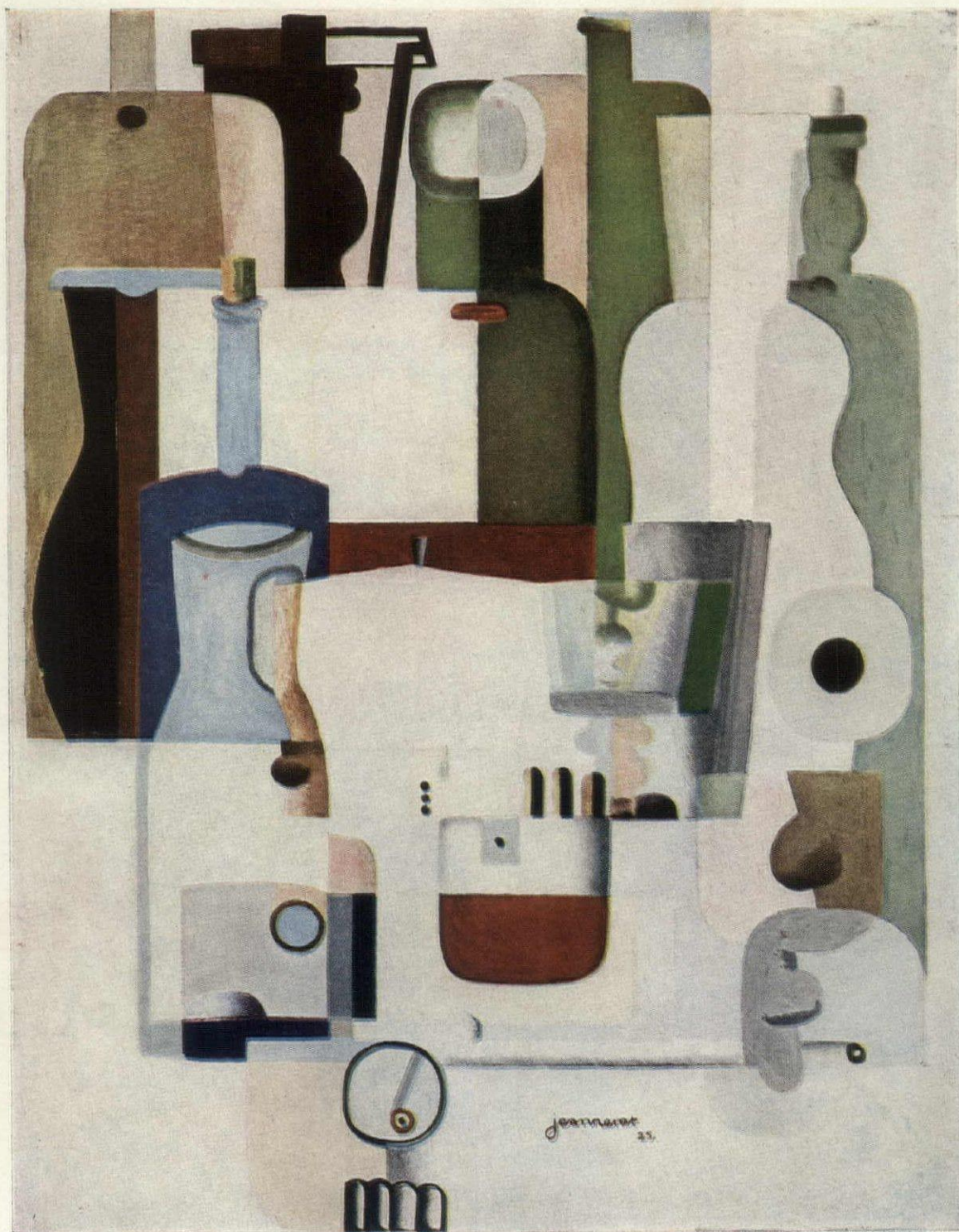

A walkaway winner in Floor Coverings!



PHOTOS OF JOHNS-MANVILLE "TERRAFLEX" COURTESY JOHNS-MANVILLE CORP.



There's something new underfoot today—with more and more manufacturers turning to VINYLITE Brand Plastics as the material for floor coverings. And the reasons are powerful ones.

VINYLITE Brand Plastics are highly resistant to soaps, cleansers, grease and oil, and to acid and alkali solutions. They are extremely resilient—yet outwear other types of floor coverings. Their colors are clearer, and can be lighter in tone than possible ever before in resilient flooring.

Highly flexible, they conform to uneven floor surfaces and absorb normal play of wood floors—without cracking! They can be safely laid on concrete floors in direct contact with the ground. No resilient floor covering takes on greater luster when waxed, yet waxing is not necessary because the surface is non-porous and dirt does not penetrate.

Colors are as varied as the rainbow's with matchless stability.

And VINYLITE Brand Plastics provide floor tiles and continuous flooring of utmost wearability and ease of maintenance.

It will more than repay you to investigate their advantages for public buildings and private homes. A list of suppliers of floor coverings made with VINYLITE Brand Plastics will gladly be furnished. Write Department EH-14.

Vinylite
BRAND
PLASTICS

TRADE MARK
BAKELITE
CORPORATION

BAKELITE CORPORATION, *Unit of Union Carbide and Carbon Corporation*  30 East 42nd Street, New York 17, N. Y.

For
Simplicity of Installation

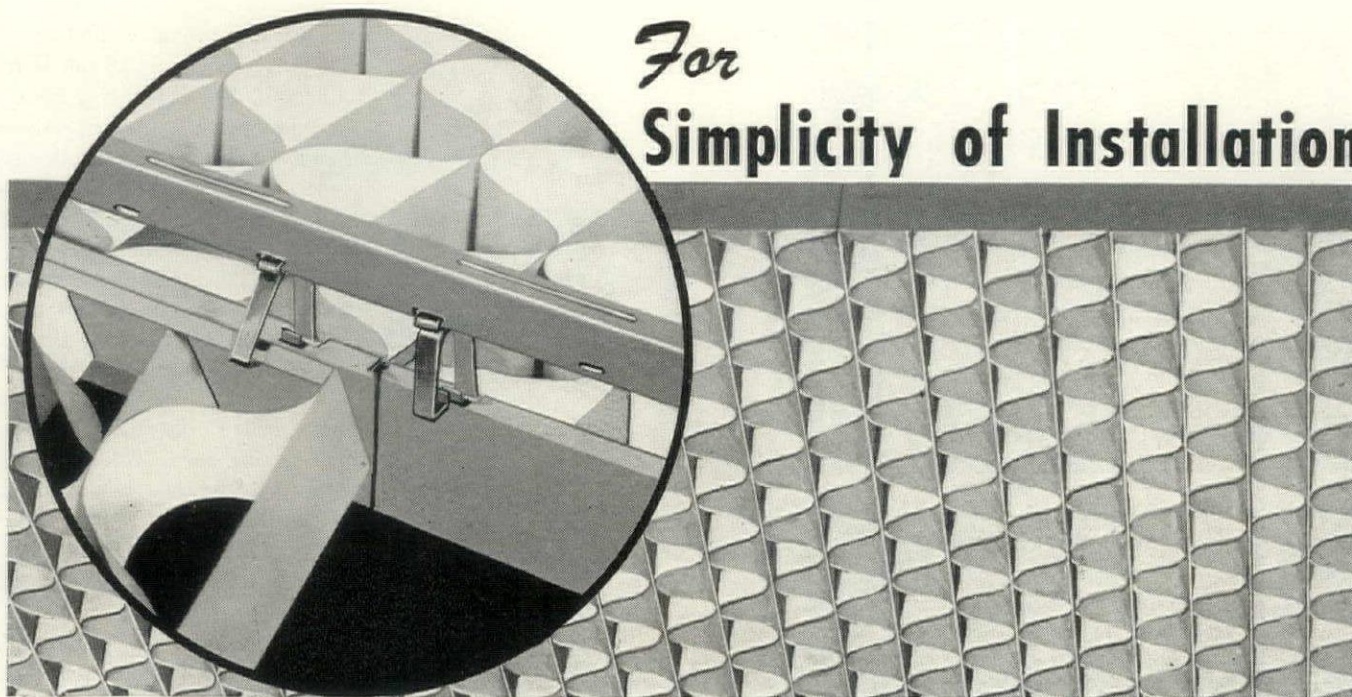

Specify
FEDERAL Cell-Ceil *

THE COLORFUL DECORATIVE LIGHTING TREATMENT

Specify Federal Cell-Ceil and you simplify installation problems. The light-weight sturdy hanging mechanism developed for Cell-Ceil not only speeds up application but provides such easy access for relamping and cleaning that continued satisfaction to the client is assured.

Federal Cell-Ceil makes overall ceiling lowering practical in remodeling as well as new construction.

Wherever you specify Federal Cell-Ceil you assure those who work and live under this louvered ceiling a soft diffused light. With all direct glare reduced and bad effect of sharp shadows eliminated, uniform lighting is provided that allows better, easier-on-the-eye seeing.

Cell-Ceil comes in harmonious decorator colors. It is made of Acme Galva-Bond Steel** that offers protection against loss of color or corrosion. For the latest information, let us send you our Technical Bulletin on installation techniques.



*Trade Mark "Cell-Ceil" applied for.
 **T.R. Acme Steel Co.

FEDERAL ENTERPRISES, INC.
 FORMERLY FEDERAL ELECTRIC COMPANY, Inc.
 8700 SOUTH STATE ST. • CHICAGO 19, ILLINOIS

COUPON

Dept. CCT-8
 Federal Enterprises, Inc.
 8700 S. State St., Chicago 19, Ill.
 Please send your Cell-Ceil Technical Bulletin
 on installation techniques.

NAME _____ POSITION _____
 FIRM _____
 ADDRESS _____
 CITY _____ ZONE _____ STATE _____

BERTHA SCHAEFER'S MINIATURE HOUSES are small masterpieces of contemporary design and furnishing

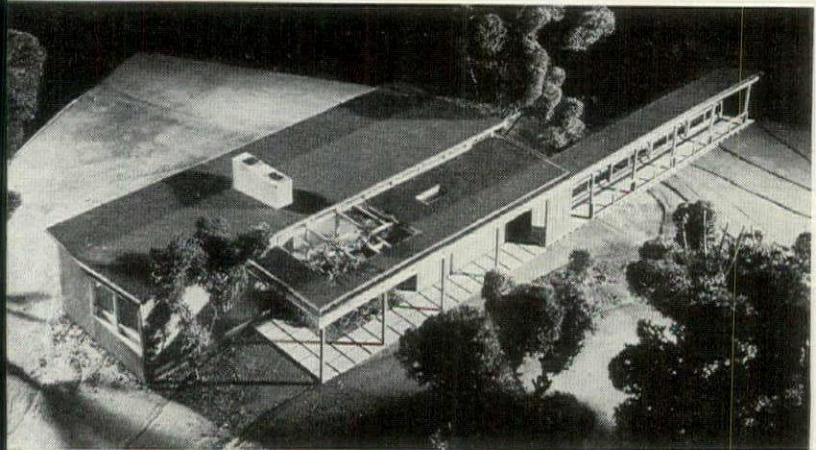
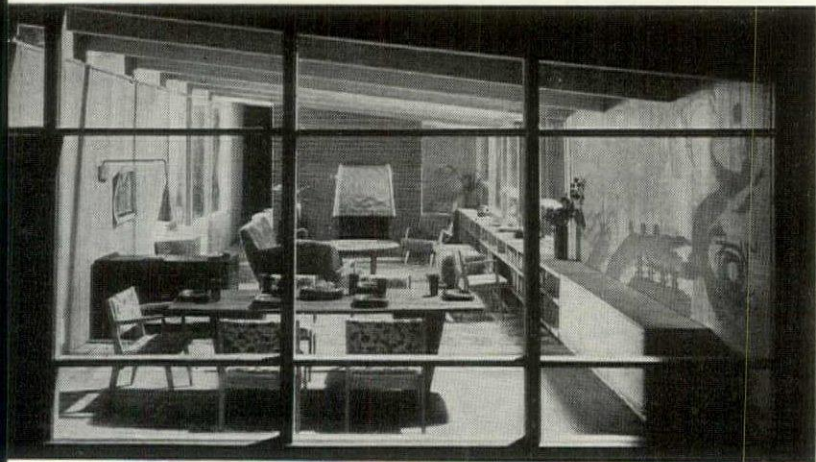

Long Island country house by Edward D. Stone Associates is an example of compact planning and artistic detail. Living room (top) features mural in deep blues and grays stained directly on wood wall. Entrance roof (above) is a Mondrian design executed in wood and colored glass. Mosaic table (top right) sets the interior color scheme of blue and mulberry.

Ben Schnall

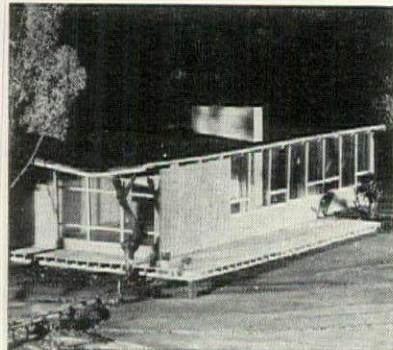
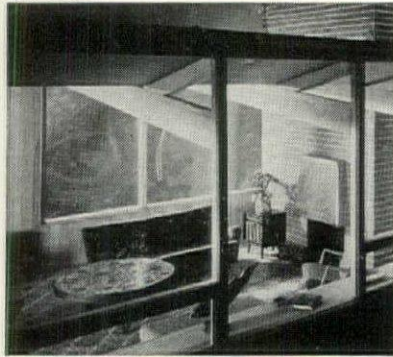

The second annual exhibition, *The Modern House Comes Alive*, at the Bertha Schaefer Gallery in New York is a more mature and unified affair than the first. Again within the limited confines of her little gallery, seven models interpret four designs by architects Carl F. Brauer; Elder, Raymond & Brackley; Reisner & Urbahn; and Edward D. Stone Associates. Collaborating landscape and furniture designers, weavers, painters, ceramists and sculptors are too numerous to list but all come straight from the top drawer. Will Turner of General Lighting worked out the illumination of the models with Miss Schaefer. Cove and spot lighting on an inch scale are most effectively used, and though in a man-size room the solution might work out a little differently, possibilities are clearly indicated.

The decorative schemes display Miss Schaefer's rich color sense, each room being built up around a single, focal piece. In the Stone house a brilliant-hued, round mosaic table by Lee Krasner is the guiding color factor; in the Brauer house, an abstract canvas used under glass as the top of a coffee table.

As last year's show would lead one to expect, every painting, sculpture, lighting fixture and water tumbler are minutely reproduced with loving care. Newest and cutest: a 1 in. scale rug of square matting. The exhibit will travel throughout the U. S. during the year. Cost for booking: \$75 plus freight. M.S.

(Continued on page 166)

Louis Checkman

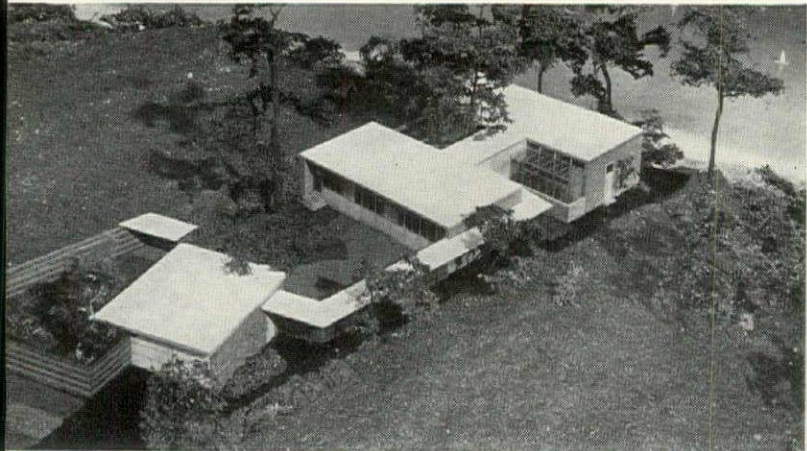

Seaside house by Reisner & Urbahn separates living and sleeping elements with H-plan, connects garage-workshop to house with long passage. Living area, overlooking sea, adjoins conservatory.

Carl Brauer house for a family with four children features a ground floor study and retreat for the parents. Combination desk-bookcase was designed by Miss Schaefer.

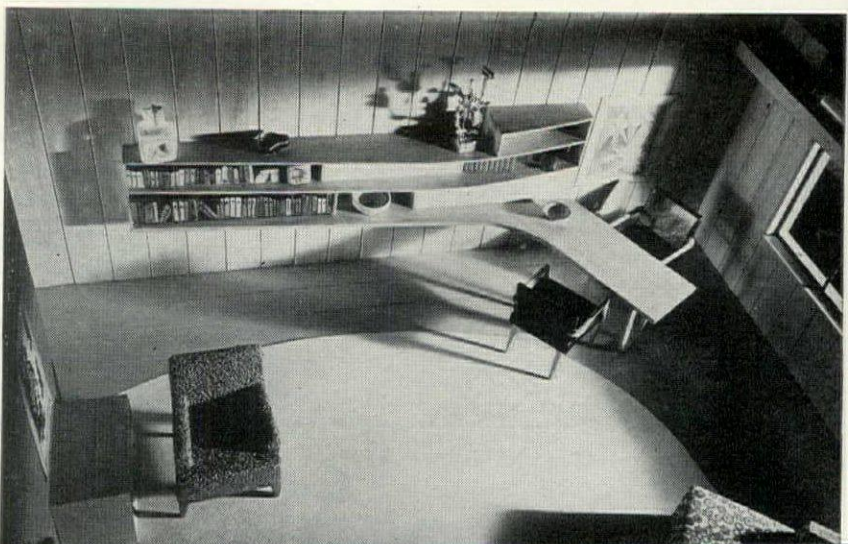



*I'm solid aluminum,
I'm not thin skinned...
I can take it!*

aluminum
is not a
substitute
..... Here's
Why

- 1 WILL NEVER STAIN
- 2 NO PROTECTIVE COATING TO BE KNOCKED OFF
- 3 EASY TO DRIVE—LAST A LIFETIME
- 4 ALMOST TRIPLE THE NUMBER PER POUND
- 5 ETCHED FOR CLEANLINESS AND HOLDING POWER

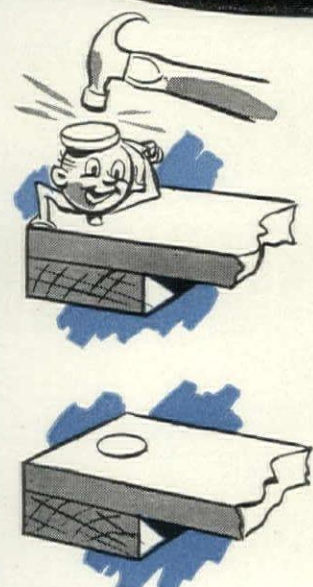

THERE'S NOTHING ON MY HEAD TO CHIP OFF!
I'll never produce red rust or green oxide and ruin a paint job. Beat me on the head — I can take it!

HOW DO I DRIVE? SWELL!
Billions of me have been driven in all kinds of woods.

HOW DO I HOLD?
Listen, I'm etched all over from head to tip. I cling to wood fibres and grip tight — besides I'm clean.

AM I EXPENSIVE? NO!



HERE'S WHAT YOU OUGHT TO KNOW ABOUT ME . . .

Aluminum
PLASTERBOARD NAILS
1 1/4 x 12 1/2 ga. 5/16 Hd.
cost **ONLY 2 1/4c** more per square yard than blued nails.
Based on 35 nails per square yard.

Aluminum **WOOD SIDING NAILS — 7d Box**
cost **ONLY \$1.75** more per 1000 board feet than galvanized nails and **\$4.00 LESS** per 1000 board feet than stainless steel nails.
Based on 1665 nails per 1000 board feet.

Aluminum **ROOFING NAILS**
1 x 10 ga. 7/16 Hd.
cost **ONLY 26c** more per square than 11 ga. galvanized roofing nails and **30c LESS** per square than copper nails.
Based on 332 nails per square.

Aluminum **ASBESTOS SIDING NAILS (Etched)**
1 3/4 x 13 ga. 3/16 Hd.
cost **25c LESS** per square than special alloy steel annular thread nails and **27c LESS** per square than stainless steel annular thread nails.
Based on 173 nails per square.

Consumer price comparisons are approximate, and are based on mill dealer prices plus identical percentage mark-up; freight not included. Higher prices than the above mill basis on the competitive nails shown above change all comparisons in favor of aluminum.



NICHOLS WIRE & ALUMINUM CO.
MAIN OFFICE AND FACTORY: DAVENPORT, IOWA
Warehouses: Mason City, Iowa • Battle Creek, Mich.

South Bend's Institute House

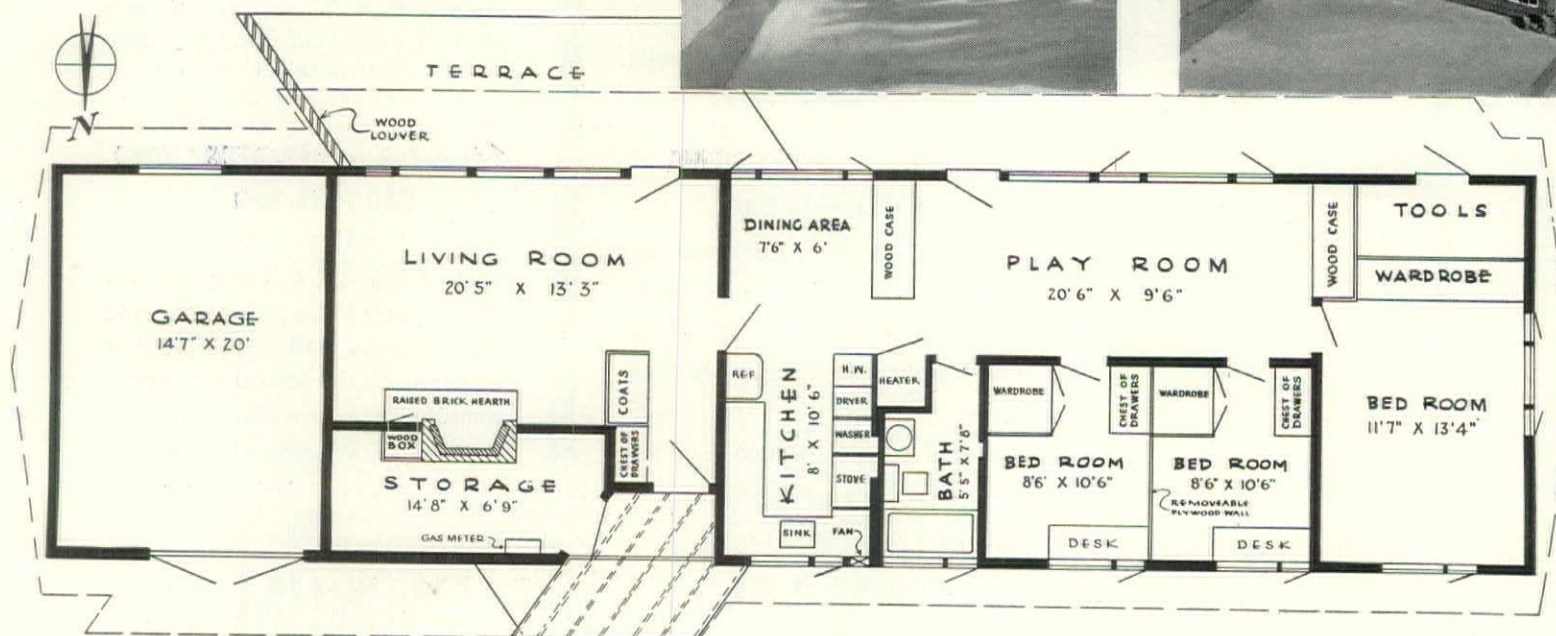
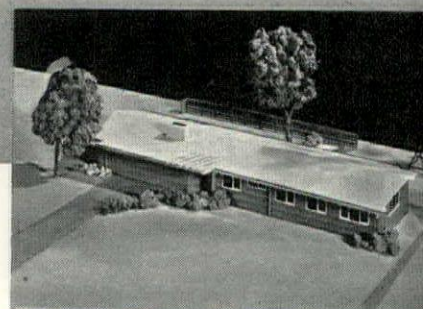
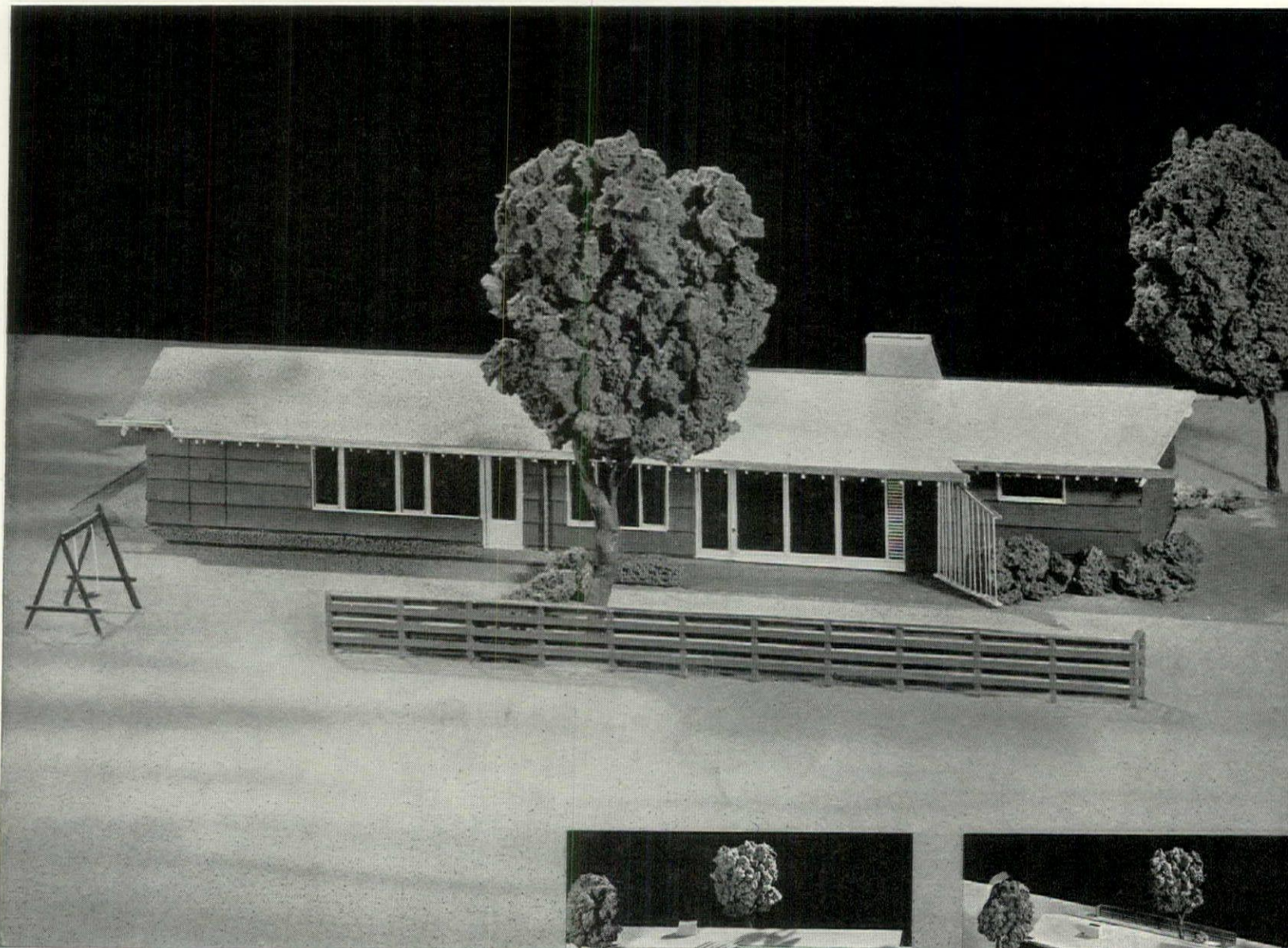

... built for an Active Family

by **L. Morgan Yost** *Architect, Kenilworth, Illinois*



THE primary assumption in designing this house is that it would be for a family with children. Too many houses have followed the time-worn formula of living, dining, kitchen and bedrooms with no special place for a growing family to have its varied activities.

"Our lot is a corner 63.75 feet by 136.73 feet with the long street side to the north. Side-lot restrictions were severe so we placed the house as far north as possible to allow maximum yard and garden to the south. We have planned an attenuated house to reserve this open space.

"In general, the house is divided into two areas, one for 'polite living', the other for family play and work. The play-work room is really an enlarged hall so that we have no lost hall space. Children coming in from play may hang up their coats, go directly to the bathroom and then in to have lunch without passing through any other part of the house. The kitchen-laundry has easy supervision over both the play area and the play yard, though it has carefully been placed to avoid the seemingly constant supervision which would result had the kitchen sink window overlooked the play yard. The kitchen-laundry is lighted by a north window, while a large bath in the dining area will assure plenty of cheerful sunshine in the room when it is designed. Needless to say the convenient location of the bath, appreciated by the mother, brings economy into the concentrated plumbing system.

"The two children's bedrooms opening off the play-work room are small but very carefully planned to give each child his requirement for privacy. If he needs greater space he uses the play-work room, of course. Each child's bedroom has a bed with a bookshelf over it, a closet with shelves behind for the storage of paraphernalia, a chest of drawers with a mirror over it, a desk with plenty of drawers lighted by a north window, and an extra upholstered chair. These bedrooms could even accommodate double deck beds if necessary. The master bedroom has ample wardrobe space and room for twin beds if desired.

"The play-work room is well lighted and has a large case at one end for the storage of games and any other work or play items. At the other end is a large wardrobe for children's out-of-door clothes as well as some of their games and toys.

"Both the kitchen-laundry and the living room have been planned to avoid through traffic and the latter has wall space provided for a piano as well as for the usual sofa. A fireplace has a woodbin which is fed from the storage room which separates the living room from the street. More storage is found at the side of the garage. The roof overhang gives protection between the entrance door and the garage. At the other end of the house opening to the playground is a special outside closet for small wheel toys and garden tools.

"It is intended that this house be built of frame construction using two-foot strips of waterproof plastic-coated marine-type plywood, lapping the joints to form a drip and deep shadow line. Sash are of wood with casement ventilators. A built-up roof with colored gravel topping shelters the house and its overhanging eaves line is broken to produce accent, protection or interesting shadows as the

case may be. The devices over the entrance canopy have copper ridges poking up through the gravel roof to produce a pattern as an entrance accent and to bring water, during winter thaws, over the edge to produce long icicles in rhythmic pattern. The gutters extend past the end of the roof to soften the appearance and to avoid the cropped feeling that so many gable ended one story houses have. The gable end also overhangs and is slanted.

"The soil in South Bend is pure sand, and therefore we adopted a concrete post and grade beam foundation with a concrete floor slab laid directly on the sand over a membrane. This meant that one of the first considerations was the heating system. We are using a centrally-located down-circulation oil furnace with two under-the-floor loops at the perimeter of the house. These are metal ducts buried in the concrete of the slab. Thus the slab will not be cold around the edges, and a certain amount of radiant heat is utilized. However, from these ducts grill openings are let into the rooms so there is a circulation of warm air. A single high return grill at the furnace suffices.

"We are therefore introducing heat at the cold window surfaces and circulating the warm air which has risen to the ceilings. This seems to be contrary to the current practice, which is to introduce the warm air at the inside walls and to attempt to catch the cold down draft from the windows in the cold air returns.

"Interior walls are plastered, as this is the cheapest type of finish in this locality. Cases and cabinet work form many of the partitions. Our roof structure is typical truss, so the exterior shell can be erected and all interior partitions installed later.

"Plumbing and mechanical appliances are concentrated in the area between kitchen and bath.

"The extreme simplicity of the plan belies the amount of time spent on design. It is a house designed for a family with children, by an architect with children. The living room is not used for children to play, but is reserved for quiet living and entertainment. Work such as laundry and canning can spread into the dining area, even into the play area, which indeed is an all-purpose room.

"Copper is used for gutters and down spouts, flashing, water piping, screening, furnace and plumbing lines, vent hood, and of course in the quality electricity, plumbing and hardware items throughout."

Insist on Quality Products

Revere Building Products are a mark of quality. They give lasting protection against damage because they cannot rust. Trouble always costs more than Revere Products. They include: Sheet Copper for flashing, roofing, gutters, downspouts, cornices and the like; Copper Water Tube for plumbing and heating lines, including radiant panel heating; Red Brass Pipe for water lines; Revere Home Flashing, a packaged product complete with illustrated instructions for approved installation; Sheet Copper and Herculoy for water heaters and storage tanks; Brass and Bronze for weather strips, hardware and plumbing fixtures; Architectural Bronze and Aluminum extruded shapes for thresholds, window frames and the like. These quality products make a house easier to sell or rent, and add materially to its value... A Revere Technical Advisor, Architectural, well acquainted with the selection and application of Revere Metals, will be glad to consult with you without obligation.



Revere Quality House Institute

This is an independent, non-profit organization sponsored by Revere Copper and Brass Incorporated as a public service, and co-sponsored by The Architectural Forum. John Hancock Callender, Architect, is Executive Secretary. During this year eight different architect-builder teams are constructing eight Revere Quality Houses in eight different sections. Associate Member Teams can be organized.

REVERE QUALITY HOUSE INSTITUTE

John Hancock Callender, Architect
Executive Secretary

P. O. Box 1134, Grand Central Station
New York 17, N. Y.



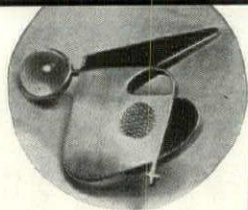

Shop exterior is two-story showcase. Pin (above) is by Margaret de Patta; (below) a Storgewall installation.

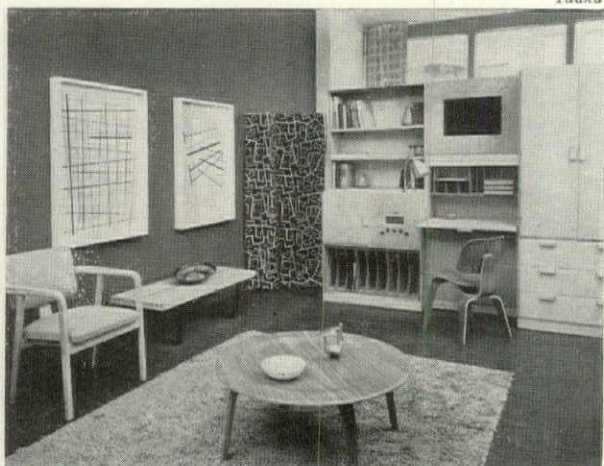
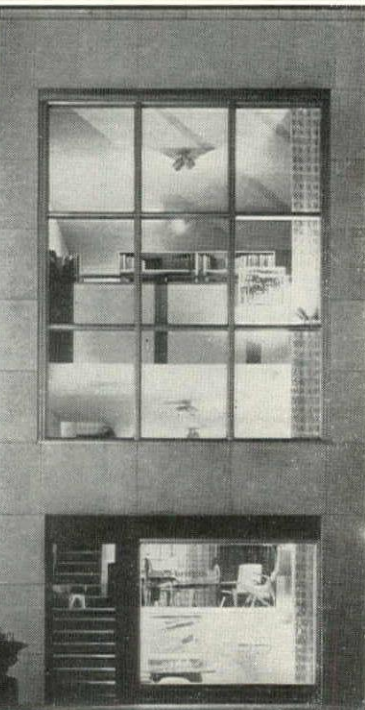

Idaka

REVIEWS

BOYD-BRITTON ASSOCIATES

More commercial in purpose than the Bertha Schaefer shop but of comparable design merit is Boyd-Britton Associates store in Chicago. It came into being a little over a year ago and caters to a select, sophisticated, contemporary-minded clientele. Merchandise includes furniture, lighting fixtures, fabrics, ceramics, sculpture, glassware, jewelry and occasional collections of paintings.

The tiny band-box of a building presents an open facade with three levels of display visible from the street. At night the entire interior is effectively illuminated as a unit.

The backbone of the current collection is the Storgewall, the living room section of which has been assembled in the upstairs showroom (see cut). Other furniture is by Charles Eames, George Nelson, Isamu Noguchi and Hans Knoll with Kurt Versen and Von Nesson supplying the lighting fixtures.

For a store, the general display is made unusually pleasant by informal groupings of various types of merchandise which completely ignore standard departmentalization, except for such things as fabrics and wallpapers which must be kept grouped and catalogued to a certain extent. However, where possible, larger quantities of these are used as curtains, draperies, etc. Representative of the textile and wallpaper selection

Idaka

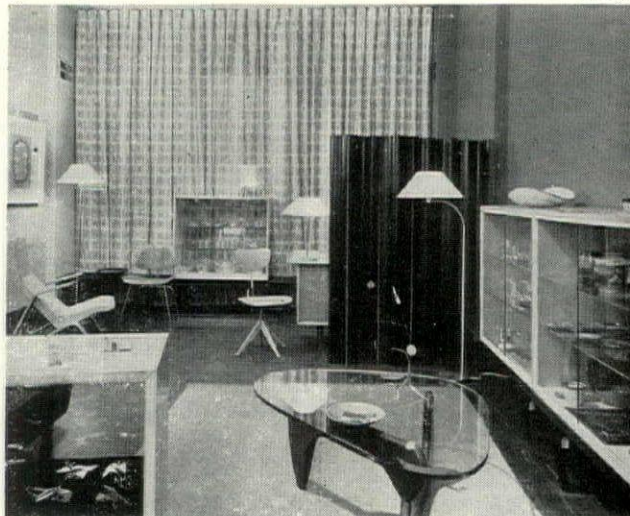

Merchandise ranges from jewelry to large pieces of furniture. Note handsome glass and wood table by Noguchi (foreground).

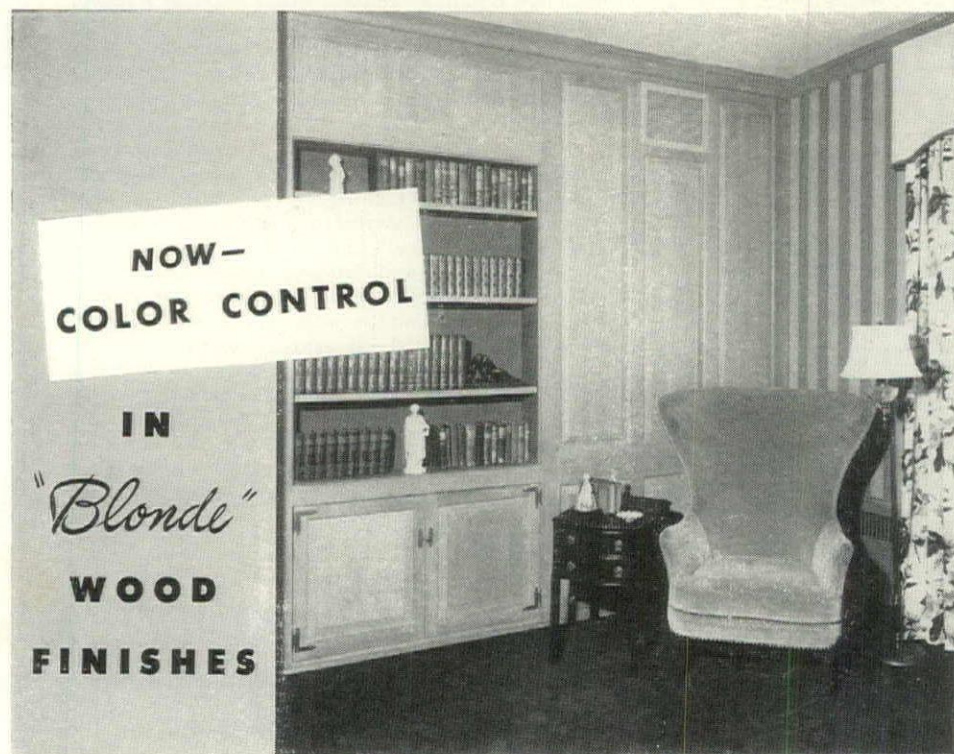

NOW -
COLOR CONTROL

IN
"Blonde"
WOOD
FINISHES

PEN-CHROME WOOD FINISHES OFFER 10 USEFUL MODERN TINTS

Pen-Chrome "Blonde" Wood Finishes make it easy to harmonize the color of wood paneling, plywood, woodwork, trim with the color-scheme of any room or interior—give the designer new freedom and control in finishing wood surfaces!

Pen-Chrome brings out the natural beauty of wood as it seals, water-

proofs, dries to a soft, lustrous finish. Its economy suggests a wide variety of applications in homes, stores, offices, hotels, institutions.

See your O'Brien dealer today, or write on your letterhead for new color folder and free sample. The O'Brien Corporation, 101 N. Johnson Street, South Bend 21, Indiana.

IN 10 USEFUL MODERN TINTS: Maple, Sandalwood, Bleached Mahogany, Driftwood, Platinum, Blonde, Light Oak, Dark Oak, American Walnut, Mahogany



By the Makers of Famous...
O'BRIEN
PAINTS

are designs by Angelo Testa, Ellenhank, Lillian Garrett Roscoe and Majel Chance. Boyd-Britton also carries ceramics by Eugene Deutsch, the Natzlers and Polia Pillin and a well rounded line of Kösta Swedish glass. On display from time to time are paintings and sculptures by such artists as Serge Chermayeff, Carlos Merida, W. Paalen and others.

Among such a galaxy of names it is not surprising to find the sculpture and jewelry of Alexander Calder but it is somewhat startling (though very pleasant) to find Margaret de Patta's incomparable jewelry turning up in the middle west. This is headline good news as most of her fans east of the Rockies had begun to suspect that the State of California had something on her.

By and large, Boyd-Britton packs a bushel of well designed products in a peck-size building. Hitherto, only New York and a couple of West Coast cities enjoyed stores adhering to a similar standard of excellence. Hope is that its appeal will inspire organizations of the same type in smaller cities. M.S.

(Continued on page 168)

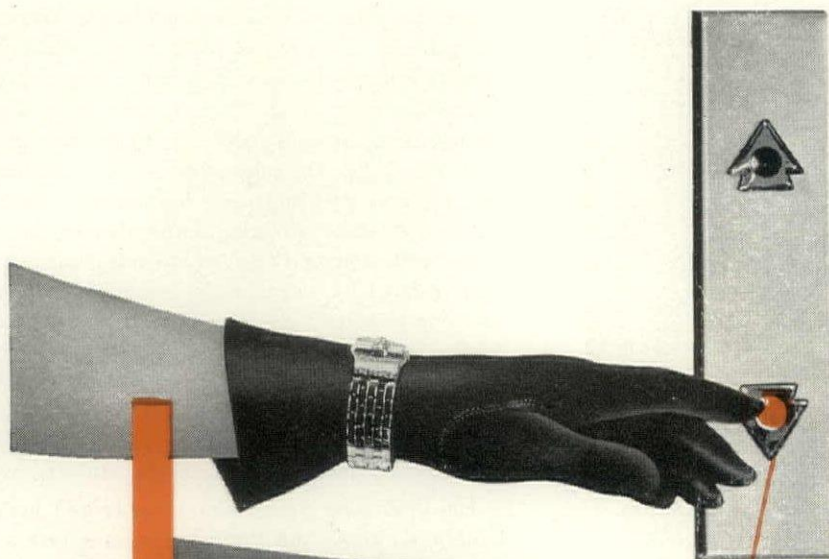

OTIS ADDS

**a 'touch' of startling newness
TO SIGNAL CONTROL ELEVATORS**



FOR THE PASSENGERS—it's a 'touch' of magic. It's the newest way to call an elevator. How? By simply *touching*, not pushing, a plastic arrow in the landing fixture. What happens? The electronic 'touch' button lights up. A soft-toned gong announces an approaching elevator as the overhead lantern lights up. The passenger steps toward the entrance, the doors open—and she's on her way. How's it done? With a magic brain—the *electronic panel in the control room*—as pictured below.

FOR THE BUILDING—Electronic Signal Control is a 'touch' of magic that reduces round-trip travel time . . . permits each elevator to make more trips, carry more passengers . . . eliminates all unnecessary car travel . . . speeds passenger handling.

Otis Electronic Signal Control is now available for your building. For further details call your local Otis Elevator Company office.



**ELECTRONIC SIGNAL CONTROL
ELEVATORS**

AS ALWAYS, OTIS LEADS THE WAY . . . THIS TIME WITH THE MAGIC OF MODERN ELECTRONICS

REVIEWS



Moulin Studios

REFURBISHED MUSEUM

From the point of view of remodeling, Nineteenth Century art galleries seldom offer more promise than the traditional sow's ear but, with relatively simple *legère de main*, the San Francisco Museum of Art has come up with some interesting changes that are both striking in appearance and sound from a display angle. The renovation called for no major structural changes but strict budgetary limitations made the problem a bit tickler. Whereas formerly, in all galleries, the cloth covering of the walls extended from an obsolete chair rail to the ceiling, it has been substantially lowered and the rail removed, allowing pictures to be hung for the first time at proper eye level height. This bit of reupholstering also gave the Museum a good excuse to toss the traditional monkscloth into the dustbin and replace it with light gray cotton cloth imported from Mexico. Monkscloth in art galleries, like golden oak in schoolrooms, smothered its own purpose some years ago.

The Decorative Arts Gallery (see below) has an L-shaped built-in showcase and the entire area sports a furred-down grid ceiling covered with cloth which helps to filter existing sky-lighting as well as providing support for auxiliary spot



lighting. A particularly interesting display unit is at the entrance to the Arts and Skills exhibit (see cut left above) comprised of a rope laced frame which serves as a spatial barrier, at the same time supporting a semi-suspended display table. In the Photography Gallery, wall cloth has been dyed a terra cotta to set off the black and white displays.

Space which once housed classrooms has been converted into offices and, in turn, one of the larger galleries now provides two generous classrooms as well as a members' lounge separated by movable walls. Fluorescent lighting in the corridors has made formerly unusable space available for hanging

Within financial limits set forth, the San Francisco Museum has done a competent bit of work in transforming fusty old galleries into pleasant, well lighted exhibition units. M.S.

SCULPTURE

Speeding the bum's rush being given to all that is static, sculptor Milton Hibald has launched some novel and intriguing figure groups of which "Aerialists" (see p. 172) is perhaps the most refined. Unaccustomed as we are to taking the arts lightly, these detachable, demountable, interchangeable acrobats give cause to wonder if sculpture, in order to be of quality, must remain unchanging and almost humorless.

(Continued on page 172)

EASY...

EVEN FOR A CHILD!

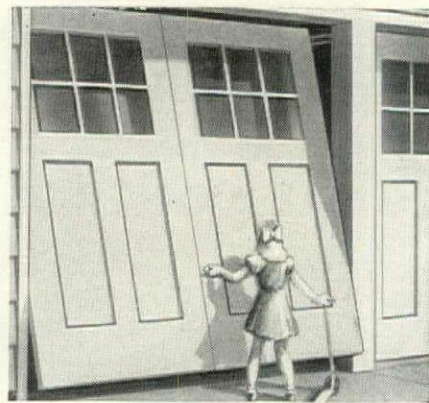

To Provide the Newest, Most Modern Overhead Door Convenience

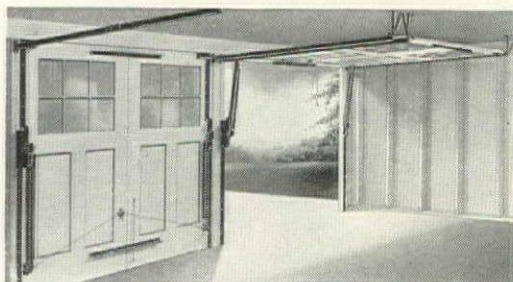

Specify

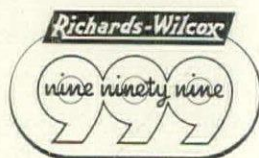

GARAGE DOOR HARDWARE

Ordinary obstacles, and seasonal "headaches" such as slush, snow, and freezing temperatures are nothing to worry about when garage doors have been converted to the overhead door convenience made possible by Richards-Wilcox Garage Door Hardware. And with the new R-W nine-ninety-nine line the conversion process is swift, easy, economical. Everything needed for installation and operation, all hardware including tracks, comes complete in one carton. Requires only 1/2" headroom.

For modernization, or in planning new structures, specify overhead garage doors with R-W 999 Hardware, and be sure of doors that will function smoothly, quietly, effortlessly—so easy even a child can operate them. For further information about R-W 999 Garage Door Hardware, call the nearest Richards-Wilcox office, or write for free folder.



1880 1948
LEADERS IN DOOR HARDWARE
OVER 68 YEARS

Richards-Wilcox Mfg. Co.

"A HANGER FOR ANY DOOR THAT SLIDES"
AURORA, ILLINOIS, U.S.A.
Branches: New York Chicago Boston Philadelphia Cleveland Cincinnati Washington, D.C.
Indianapolis St. Louis New Orleans Des Moines Minneapolis Kansas City
Los Angeles San Francisco Denver Seattle Detroit Atlanta Pittsburgh



REYNOLDS *Lifetime* ALUMINUM GUTTERS AND DOWNSPOUTS

Visually, a non-staining white metal eave trim. Functionally, an efficient rain carrier of rustproof permanence at about half the cost of other rustproof materials. 5" gutters in the designs shown, each in either plain or stippled-embossed finish. Matching downspouts and complete fittings. Application by slip connectors. Write for literature.

REYNOLDS METALS COMPANY
Building Products Division, Louisville 1, Ky.
Offices in 32 Principal Cities

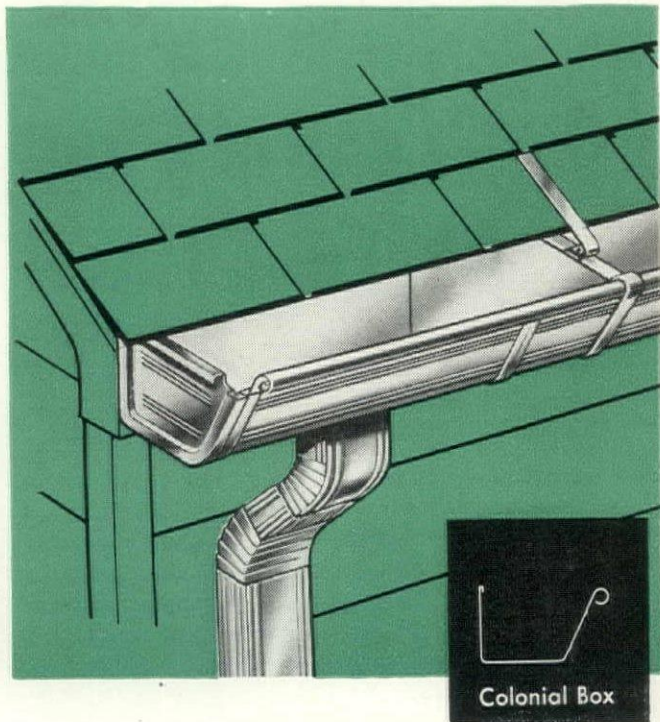
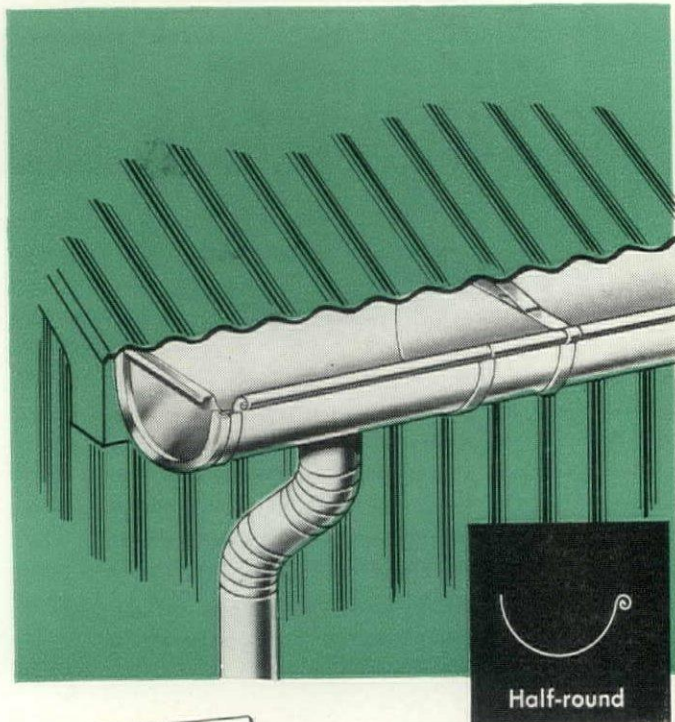
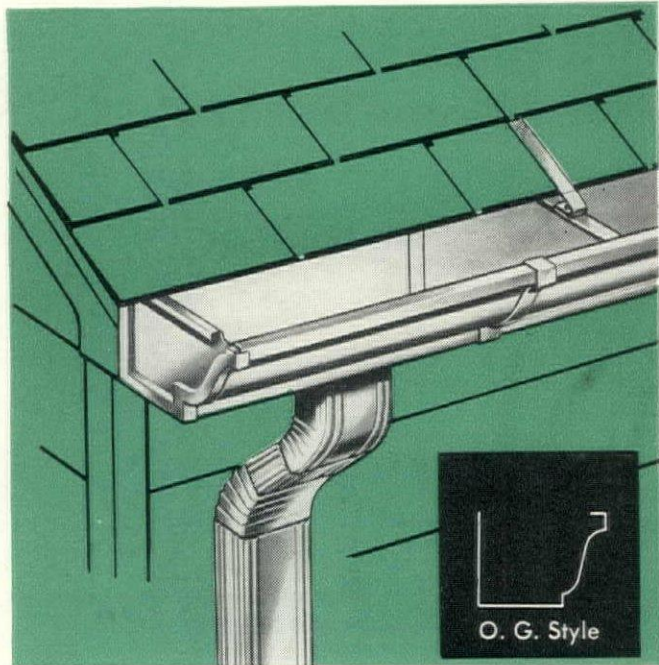

IF YOU SEE RUST
YOU KNOW IT'S NOT
ALUMINUM



REYNOLDS
Lifetime ALUMINUM
BUILDING PRODUCTS

Reynolds Pioneering made Aluminum
Competitive . . . take advantage of it!

WORLD'S LARGEST PRODUCER OF ALUMINUM BUILDING PRODUCTS:

Shingles, Clapboard Siding, Corrugated and 5-V Crimp, Snap-Seal and Standing Seam Roofing, Weatherboard Siding, Built-up Roofing, Nails, Gutters, Wall Tile, Windows, Reflective Insulation, the "Alumi-Drome" (prefabricated utility building).

"Building Block Design"

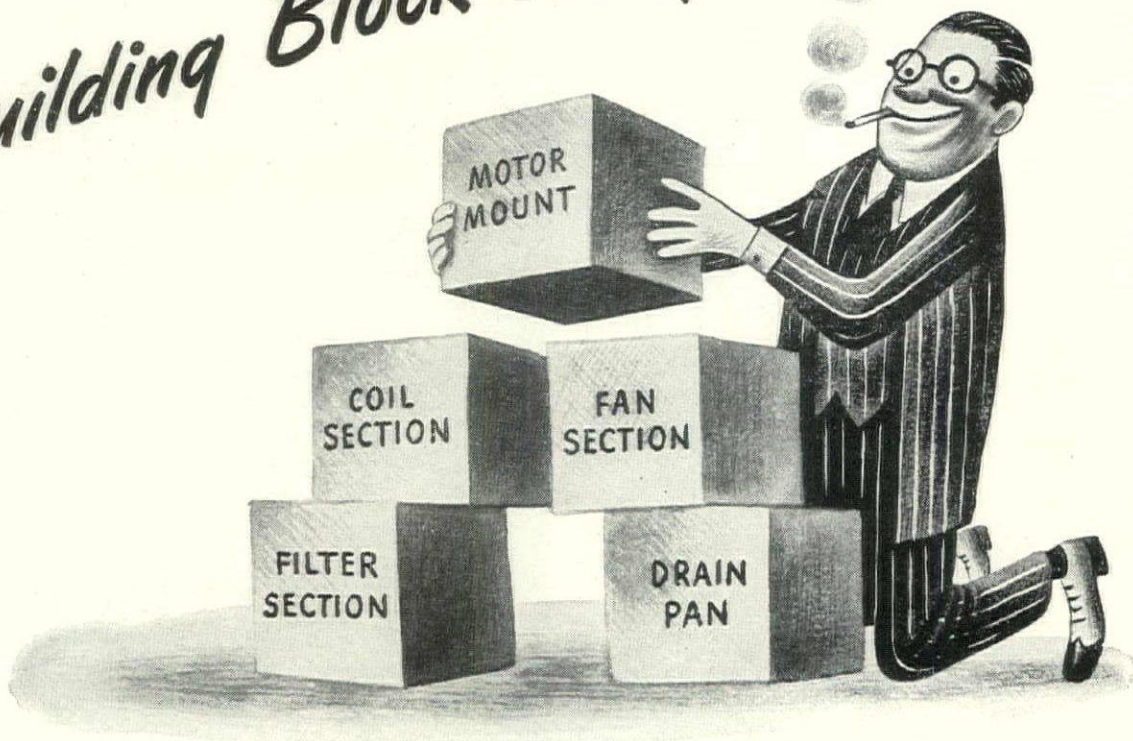

MAKES INSTALLATION QUICKER...EASIER

with a



**Central Plant
Air Conditioner**

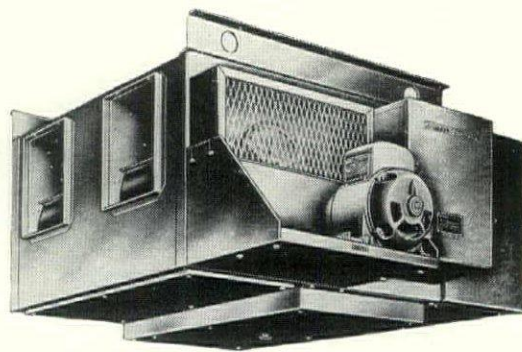

THERE ARE 28 DIFFERENT WAYS you can arrange General Electric Central Plant Air Conditioners to make the most efficient use of your space.

Coil connections and motor can be placed at either side... filters at front or rear... air discharge horizontal or vertical. You can pick the exact arrangement you want from easy-to-use selection sheets. Simply designate the arrangement you want and the unit will be shipped to you pre-matched in either vertical or horizontal models.

All sections of the larger G-E Central Plant Air Conditioner can pass easily through a standard 30" door... the two smallest models completely assembled. Ideal as heating equipment, this line covers a heating range from 28,100 to 1,310,000 Btu/HR. A complete line of heating coils is available. Cooling capacities range from .8 to 58 tons.

Fill in the coupon for a free book on these new Central Plant Air Conditioners... or contact your G-E air conditioning representative.

GENERAL ELECTRIC
Better Air Conditioning

General Electric Co.
Air Conditioning Dept., Section A81310
Bloomfield, N. J.

Gentlemen: Please send me your free book on the new General Electric Central Plant Air Conditioners.

Name _____
Address _____
City _____ State _____

IT'S
YALE'S
latest engineering
achievement

NEW

PRECISION
SECURITY
QUALITY

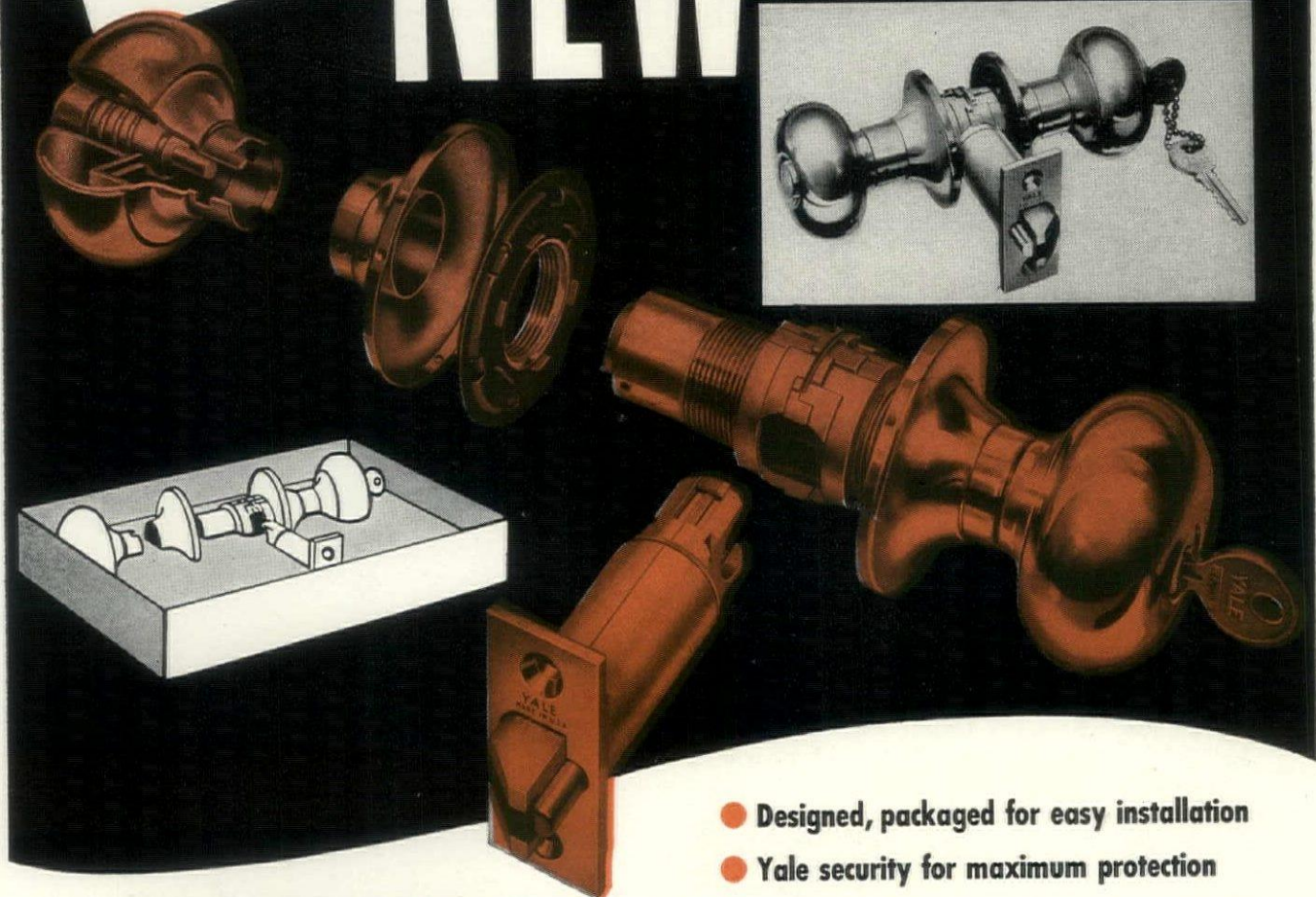

HEAVY DUTY TUBULAR LOCK

- Designed, packaged for easy installation
- Yale security for maximum protection
- Functional beauty in the modern manner

Here is a lock that sets a new standard in the construction industry. In the time it takes to ready an ordinary tubular lock for installation, you can have this new heavy duty lock on the door! It's packaged in "exploded" form, with each unit in proper relative position (as shown above) for quick four-step assembly . . . in seconds.

But first and foremost, it's a YALE lock, and that means secur-

ity, *real* security. When locked, the knob, though rigid, is completely disengaged from the rest of the mechanism.

You might expect a lock that saves construction time and offers *maximum* protection to stop there. YALE'S new heavy duty lock has many more features! The beauty of its clean, classic lines, combining artistry with utility . . . its quiet operation through balanced design

of knobs and bolt . . . the small cross bore required for installation, saving the strength of the door . . . reversibility on the job.

In simplicity, in styling, in convenience, here is the "last word" in heavy duty locks—produced by YALE, to leading architects and builders the *first word* in builders' hardware. THE YALE & TOWNE MANUFACTURING COMPANY, STAMFORD, CONNECTICUT.

FOR HOMES the standard duty tubular lock by YALE offers protection and convenience at low cost. A universal lock, it is packaged for simple step-by-step installation.

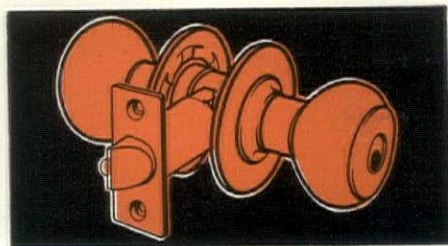

TRADE **YALE** MARK

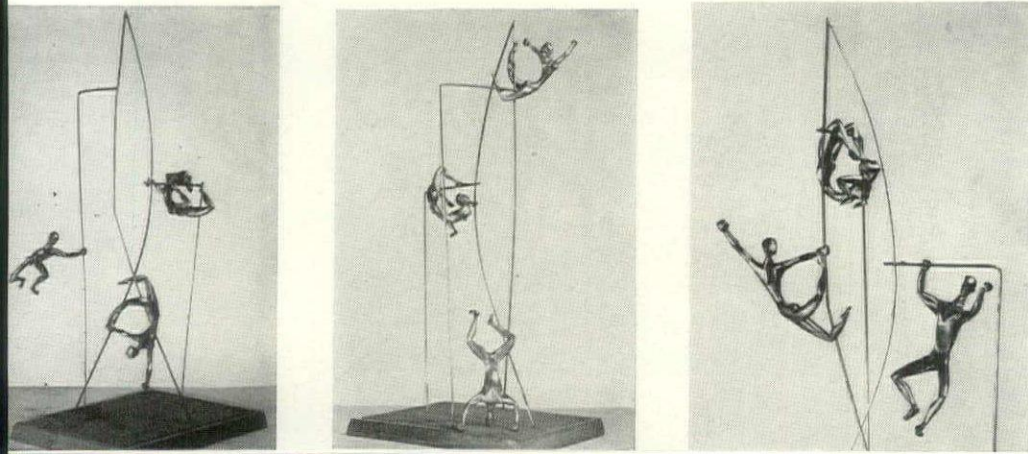

The pictures show only three of the many possible combinations for this group. Not only can the individual figures be attached to the wire at any given point, they can also be linked to each other to form the most intricate Barnum & Bailey patterns. This particular set is of cast aluminum.

Another of Mr. Hibald's sculptures that has attracted considerable attention is a miniature playground jungle-gym complete with kindergarten-aged denizens, who, though cast in metal, are vigorous and animated. M.S.

MONUMENT TO THE UNITED NATIONS

The accompanying model entitled "Family of Man Totem" is a proposed design by Mitzi Solomon for a monument for the UN. Theoretically, it would stand 114 ft. high and be cast in aluminum. The photograph arrived at the editorial office accompanied by a 5 ft. length of paper boldly lettered in pencil and titled *Ideology* excerpts from which we joyfully pass on to our readers to make of it what they may:

Adolph Study



"Building a house=UN
 Togetherness of peoples
 Physical=building and planting.
 Gestures of constructive effort and fruitful activity.
 Spiritual=communication
 Eye, and ear & mouth
 Sight sound
 i.e. heart and hand
 or
 soul and body
 Dualism=integration

A totem because it is dependent upon the balance and absolute interdependence of parts.
 (separate units)—a flaw in relationship and it falls.
 i.e. anti-Tower of Babel
 The plan is all

A totem because it is the celebration of gravity—the law of nature and the architect's plumb-line . . .
 The optimism of the spire more abstrusely.
 Fruitfulness: The trunk of the tree; the ritual phallus in primitive society.

Units because mass production is inextricably established as the mark of modern life. Therefore, why not? Let us not be precious. . . .

Units because aluminum would make it a feasible sculpture to make and to erect. (A real problem this scale). Because the units would be of a reasonable human scale for the eye and mind to apprise, although the total totem will be of the titanic scale of the total site-plan and building size—i.e. out of the scale to which the individual can relate himself, (a psychic hazard), but exciting. Seven units—the mystical number of infinity."

(Continued on page 176)

Specify this amazing new plastic screening



LUMITE
 will never, never,
 never
RUST!

Yes, LUMITE is GUARANTEED FOR LIFE against rust—in any climate, anywhere. And because it can't rust or corrode, it can't stain paint under windows. It's woven of saran, the miracle plastic, so tough it actually has greater impact strength than any other screen material . . . when properly framed will never sag or bulge. Original cost is little more than the cheapest screening—yearly cost is less than any.

SPECIFICATIONS:

EFFECTS OF ACIDS, ALKALIS AND SOLUTIONS—Essentially none.	WATER ABSORPTION—Immersion 24 hours, less than 0.1%.
BURNING RATE—None.	TENSILE STRENGTH, ULTIMATE (of filament)—Up to 50,000 lbs. per sq. in.
EFFECT OF AGE—None.	IMPACT STRENGTH—Greater than ordinary screening.
SOFTENING POINT—240°-280° F.	

Sold through Hardware, Lumber and Building Supply Dealers and Screen Manufacturers. Widths to fit all doors, windows and porches. For more complete information, consult SWEET'S FILE, or write LUMITE DIVISION, Chicopee Manufacturing Company, 47 Worth Street, New York 13, N. Y.

SPECIFY BY NAME

LUMITE*

Woven of Saran



"Coleman Floor Furnaces CUT COSTS, UPHELD VALUE 2 WAYS" ...For Richmond, Va., Builder



Crestview Addition No. 3, developed and built by Duke Construction Co.—heated throughout with Coleman Floor Furnaces to hold down costs, yet give top-quality automatic heating of the kind buyers want.

Buyers feel Coleman equipment proves high quality of Duke Company's houses



Ludwig Bloch, aggressive vice president of Duke Construction Co., Richmond, Va., one of the South's small home building leaders.

DUKE CONSTRUCTION CORPORATION
7100 HORSEPEN ROAD
RICHMOND, - VIRGINIA

The Coleman Company, Inc.
Wichita, Kansas.

Gentlemen:

In these days of complaints about high housing costs we have to do everything we can to hold down ceiling prices and still get the quality that customers recognize. That's why we are using Coleman Floor Furnaces. Properly located and properly installed, they reduce building costs, yet give top quality automatic heating. And what's more, Coleman Floor Furnaces are so well known that our buyers consider them real proof that we put best quality materials into our houses.

Ludwig Bloch V.P.
Duke Construction Co., Richmond, Va.

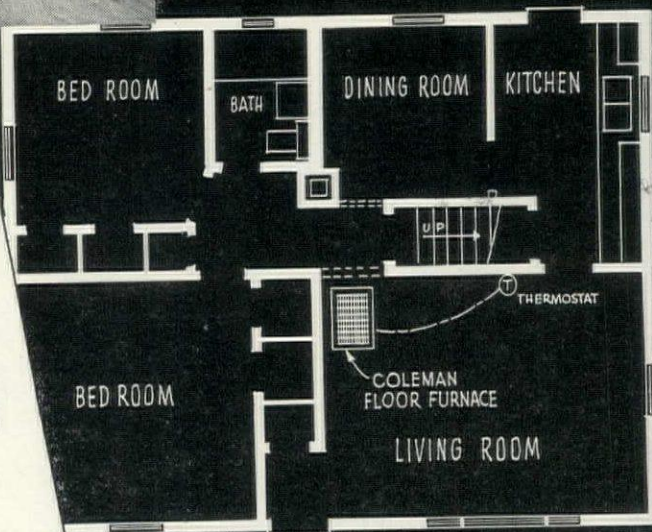

This shows typical Coleman Floor Furnace installation

See how Coleman may help you, too, in designing to beat "price resistance"

Duke Construction Company is only one of the many leading building firms now switching to Coleman Floor Furnaces. Scores of these leaders are learning how Coleman helps cut costs: eliminates costly duct work, saves basement excavation costs, cuts skilled-labor expense for installers and plumbers.

And, like the Duke company, they are also learning two other Coleman advantages: First, how Coleman engineering really gives home-owners the "warm-floor" heating and the clean automatic heat they want. Second, how Coleman reputation for quality and service helps sell houses—by proving to prospects that the builder is using the best heating equipment the money will buy.

You, too, want to see proof of these advantages that are switching so many builders to Coleman. Use the coupon below and let us tell you how we can help meet your problem of holding down building cost and selling price. Tell us what kind of fuel you want—gas, oil, or LP-gas—we make models for all three. Do it—today!

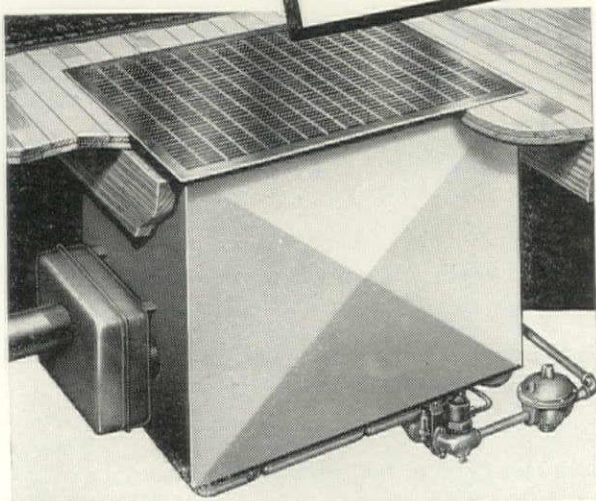

This is how Coleman Floor Furnace fits into floor. Takes no room space. No basement excavation needed. No costly duct work. No added plumbing expense.

THE COLEMAN COMPANY, INC.,

Wichita 1, Kansas; Philadelphia 8 (Terminal Commerce Bldg.), Pa.; Los Angeles 54, Calif.

Automatic Gas, Oil, LP-Gas
FLOOR FURNACES

Coleman

The Coleman Company, Inc., Builders Contract
Dept. AF-666, Wichita 1, Kans.

Please send me free information about your special cooperation for builders and contractors, and Floor Furnace Catalog for Builders. I am specially interested in:

Gas Oil LP-Gas models

Name

Address

Town

State

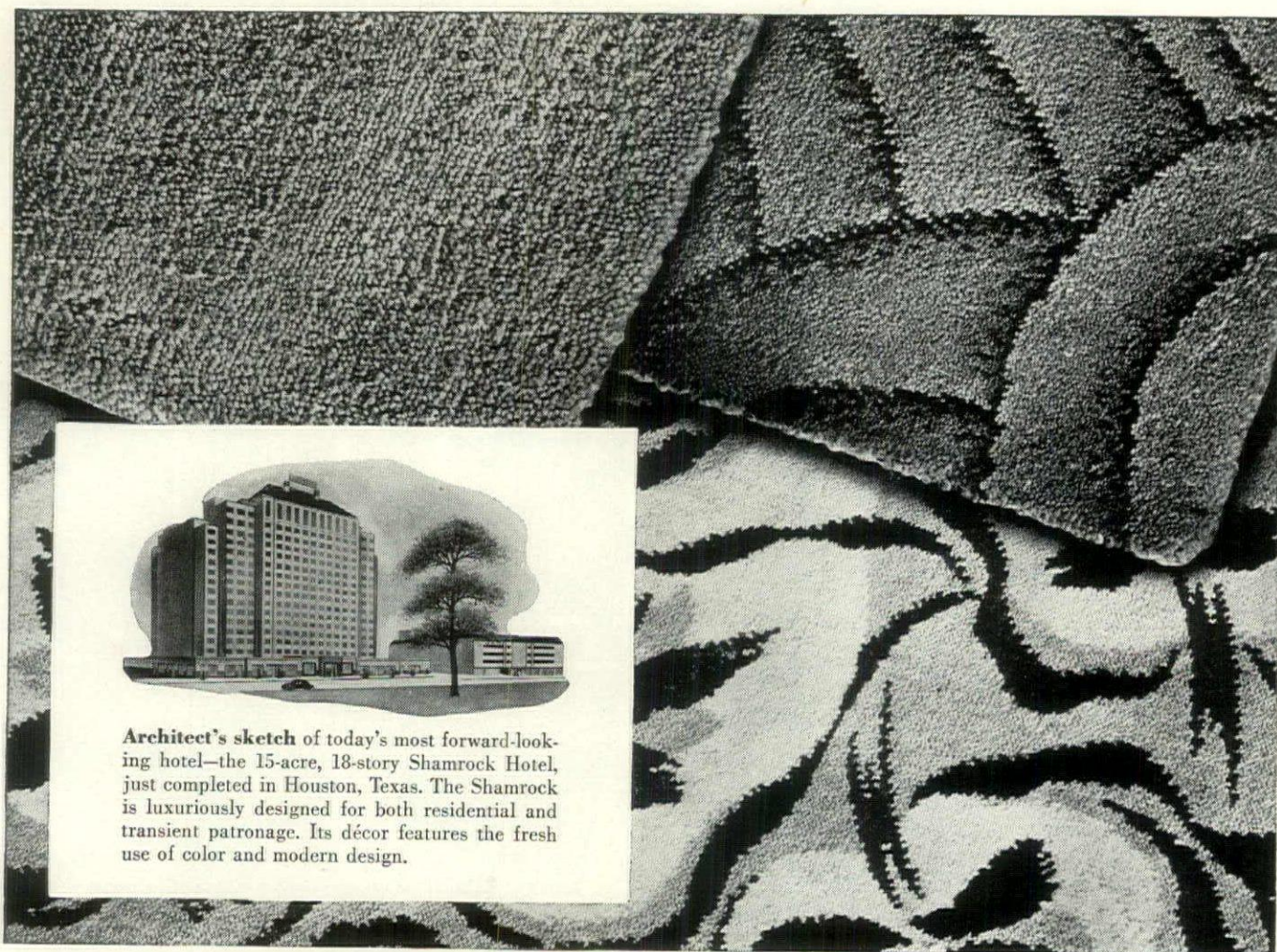

Architect's sketch of today's most forward-looking hotel—the 15-acre, 18-story Shamrock Hotel, just completed in Houston, Texas. The Shamrock is luxuriously designed for both residential and transient patronage. Its décor features the fresh use of color and modern design.

In Houston's fabulous 15-acre Shamrock Hotel at McCarthy Center...

Acres of Luxurious Bigelow Carpets



WHEN guests enter the lobby of the great new Shamrock Hotel, they'll be taking the first of many steps on superb Bigelow Carpets.

All in all, over 36,000 sq. yds. of deep, soft Bigelow Carpet spread luxury under foot. Nine special designs, made in suit-the-purpose grades, were created for this order. One entirely new grade—a figured Lokweave carpet using Saxony yarn—was created for corridor carpeting.

The entire installation was planned by interior designer Robert D. Harrell, working with the Bigelow Carpet Counsel.

And so the already-famous Shamrock joins the distinguished list of hotels, clubs, stores and corporations choosing Bigelow Carpets—where prestige and practicality must go hand in hand.

Bigelow's Carpet Counsel is available for consultation on carpeting problems which confront you in your business.

Our experts will help you select suitable carpets from the Bigelow line, or design and execute special orders. One of the 25 Bigelow Carpet Counsel offices is near you.

For the Shamrock Hotel's main lobby—Bigelow's Austrian Loom Tufted Carpet No. 90302-9, cool and shadowy, with an attractive carved effect.

In the Shamrock Room—Bigelow's luxurious and long-wearing Hartford-Saxony No. 44372-29, in a bright, festive design.

In the Bridal Suite—Sonata No. 2103-9201, a carpet so deep you could almost mow it.

Bigelow Rugs and Carpets

Beauty You Can See... Quality You Can Trust... Since 1825

ADVANTAGES OF RAYMOND CONCRETE PILES • NO. 3

uniform bearing capacity

The Raymond Method provides piles of uniform bearing capacity regardless of length of pile required. Adequate equipment and shells in sections 4 feet and 8 feet long permit driving each pile to uniform resistance with minimum shell waste.

THE RAYMOND METHOD

1. Eliminates delays in driving test piles to pre-determine pile lengths.
2. Saves time required for casting and curing precast concrete piles.
3. Permits all piles to be driven to a uniform bearing capacity regardless of variations in soil conditions.

The principal purpose of a pile foundation is to obtain uniformity of bearing over the area occupied by the structure to be supported. The complete flexibility of Raymond Concrete Piles as to length assures attaining this result with varying subsoil conditions. This is how Raymond produces foundations of the highest possible quality and uniformity.

OTHER ADVANTAGES: Greater Carrying Capacity • Permanency • Engineered for the Job • Complete Satisfaction • Saving in Construction Cost

WHY NOT CONSULT US FOR FURTHER DETAILS ON RAYMOND FOUNDATION METHODS?

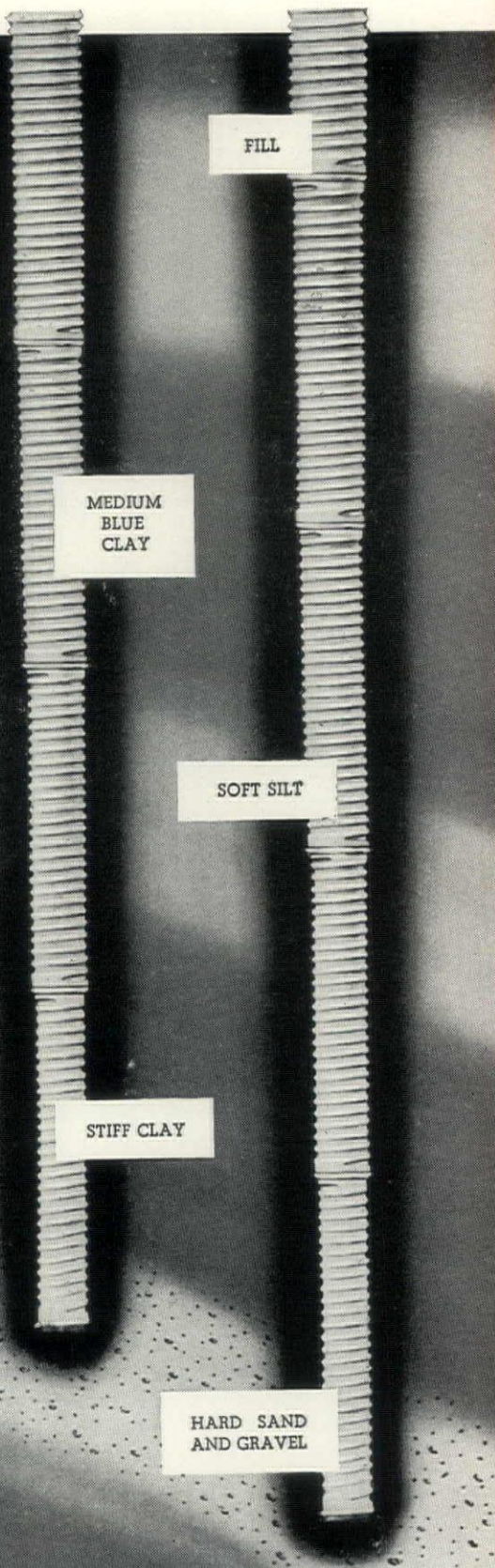

SCOPE OF RAYMOND'S ACTIVITIES... includes every recognized type of pile foundation - concrete, composite, precast, steel, pipe and wood. Also caissons, underpinning, construction involving shore protection, shipbuilding facilities, harbor and river improvements and borings for soil investigation.

51 YEARS

FOUNDED
1897

OF PROGRESS

RAYMOND

CONCRETE PILE CO.

Branch Offices in Principal Cities
of United States and Latin America

140 CEDAR STREET • NEW YORK 6, N. Y.

THE AIR YOU BREATHE SHOULD BE AS PURE AS THE WATER YOU DRINK

SAVE COSTLY SPACE WITH DIRECT DRIVE!

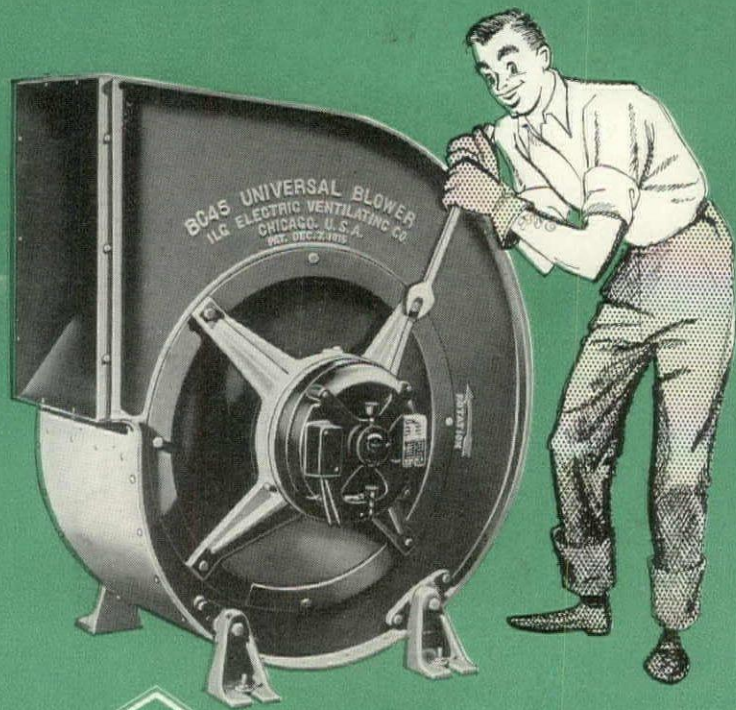

ILG VENTILATION

In these days of sky-rocketing construction costs, take a hint on space-saving from marine architects and engineers. Aboard ship, where every inch of space is of extreme importance, designers regularly specify direct-driven centrifugal fans. Not only can you measure the space saved, but also the dollars saved in labor and material costs. The net result is equipment which will stand up for years, under the stress and strain of heavy duty service.

If you are interested in saving valuable floor space, in achieving permanent alignment (no rapidly wearing parts), in saving extra costs of belts, pulleys, guards, etc., in eliminating power-wasting friction and noise, get latest data on ILG Direct-Drive Fans. Phone nearby Branch Office (consult classified directory) or send coupon.

ILG ELECTRIC VENTILATING CO., 2899 N. Crawford Ave. Chicago 41, Ill. Offices in 40 Principal Cities.

Send free copy new Catalog No. 248.

Firm Name _____
 Individual _____ Title _____
 Address _____ Zone _____
 City _____ State _____



ART IN ADVERTISING

Ten paintings by Johan Gustave Middelthon, six of them executed for an advertising campaign by the Structural Clay Products Institute, are now on display at the Architectural League in New York City. Conceived as abstract representations of the use of masonry in contemporary architecture they include such different applications as "Modern Theater (see cut); "Education"; "Modern Factory"; "Arsenals of Industry"; "Hospitals and Clinics"; "Facing Tile Montage.

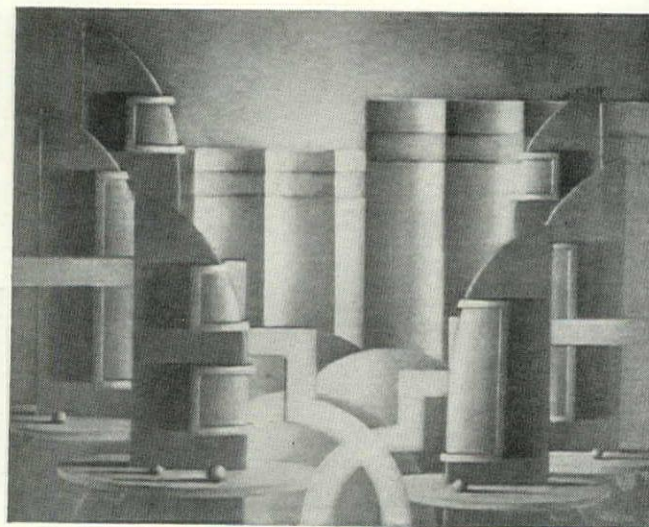

"Dynamic lines that bend to your imagination."

Douglas Whitlock, General Counsel of the Structural Clay Products Institute, conceived the idea of using abstract paintings to illustrate his product, promptly discovered his artist in the Institute's own mailroom, working as a clerk. Middelthon, who has never been inside an art school, took up painting in 1945 as an escape from his routine day work. Since then he has painted 16 canvases, some of them "derived from the patterns of music and musicians as he saw them . . . jobbing in one-night stands with a dance band around the Nation's Capitol." As stated in a brochure accompanying the exhibit: "The thought that prompted the utilization of these impressionistic, non-objective paintings as illustration in the advertisements of the Structural Clay Products Institute was born of a desire to elevate the Institute's presentations from the standard type of advertising and illuminate them with attention and recognition focused by intrigue through the use of bold unusualness." D.S.

BOOKS

SANTA BARBARA ADOBES. By Clarence Cullimore. Santa Barbara Book Publishing Co., Santa Barbara, Calif. 219 pp. Illus. 10 1/4 x 7 1/4. \$4.90.

Once upon a time there appeared an utterly absurd book called *Georgetown Houses of the Federal Period*. (FORUM, Mar. '45) which at least had the virtue of some good photographs. *Santa Barbara Adobes* is much the same type and boasts only mediocre sketches. What possible value it can have for other than purely local historical reference escapes this reviewer. Few plans are included and the drawings are sketchy—no pun intended. If anyone is hatching the idea that this book is good cribbing for suburban haciendas they're wrong. Since Santa Barbara is one of those localities where

(Continued on page 180)

What do we mean
"WEATHERTIGHT"?

HERE'S THE
SILENTITE
ANSWER

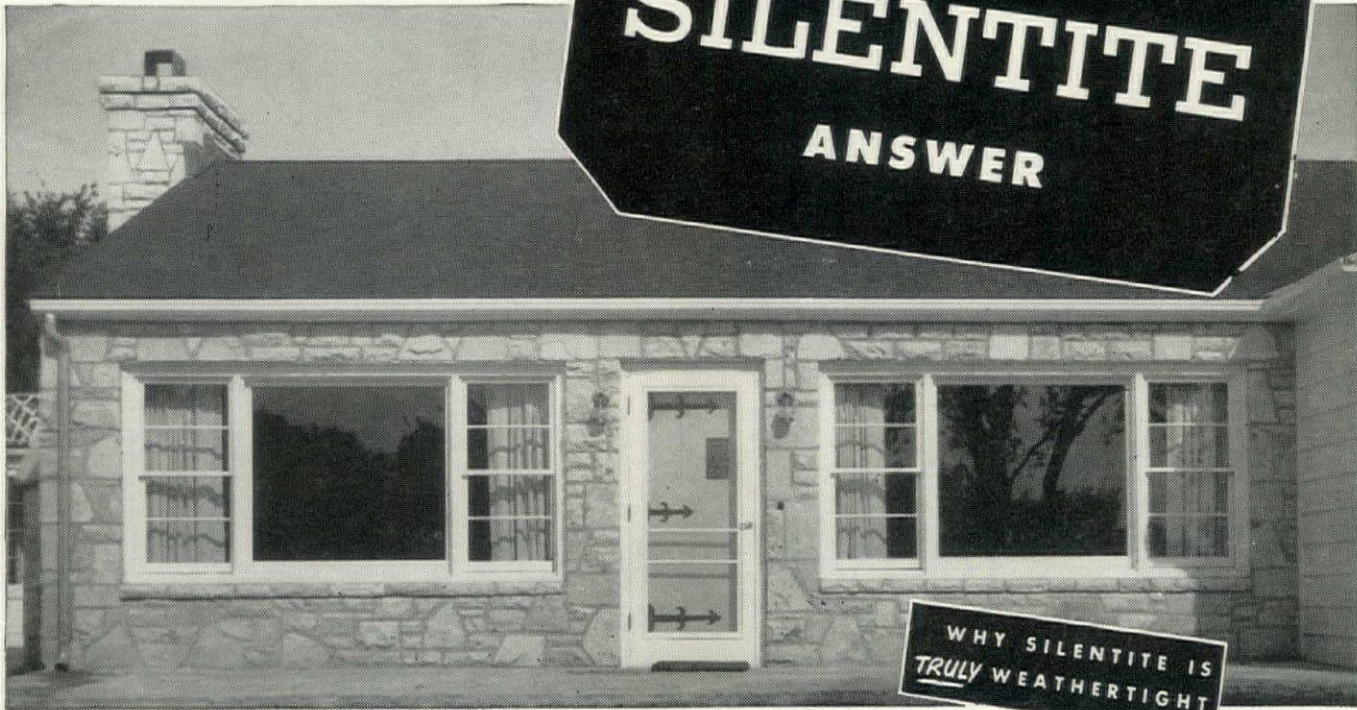

● Words can mean much—or little. But the term "weathertight"—as applied to the new Curtis Silentite window—means exactly what it implies. Here is a window *engineered* for greater weathertightness, with features representing a distinct departure from the conventional. Laboratory tests of wind velocities up to 40 miles per hour show that the new Silentite allows 20% less air infiltration even than the famous original Silentite. And because Silentite is a *wood* window, it has all the natural insulating qualities which wood provides.

When in New York, visit the Curtis Woodwork Display at Architects' Samples Corporation, 101 Park Avenue.

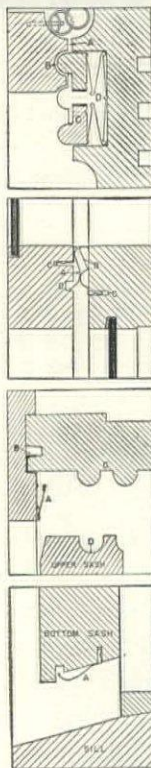

FLOATING SIDE WEATHERSTRIPS—The diagram shows the patented Silentite "floating" weatherstrips. Two beaded pine members, seated on Z-type weatherstrips, exert outward pressure, keeping firm contact with the sash, yet allowing free movement.

NEW MEETING RAIL WEATHERSTRIP—The conventional checkrail has been discarded in favor of a plain meeting rail and the wood parting stop has been eliminated. Specially designed weatherstrip members (a) on the top and (b) on the bottom sash provide positive protection from air infiltration.

NEW HEAD WEATHERSTRIP—Groove at (b) in head jamb takes the flange of the bronze spring leaf weatherstrip (a). This spring leaf is compressed by the top rail when sash is closed. The joint is further sealed by head stop (c), the head of which engages groove (d).

AT THE SILL—a plow in the bottom rail of the sash anchors the bronze spring leaf weatherstrip (a). When the sash is closed, the bronze strip (a) is tightly compressed against the sill giving positive protection against air infiltration.

Curtis Companies Service Bureau
AF-10S Curtis Building, Clinton, Iowa
Please send me book on Silentite Window Line, including casements.

Name _____

Address _____

City _____ State _____

- I am
- Architect
 - Contractor
 - Prospective Home Builder
 - Student
- (Please check above)

**AIR CONDITIONING
REFRIGERATION**

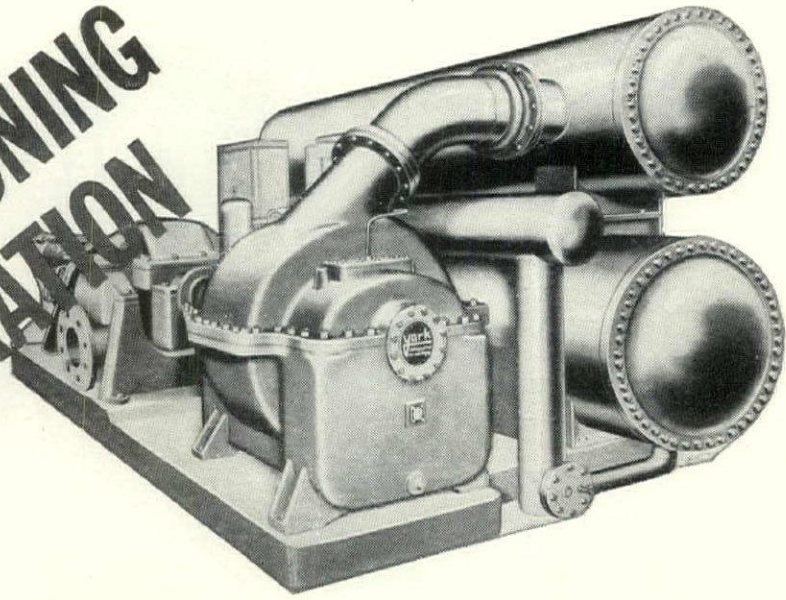

With Turbo Compressors

ONLY YORK HAS

Stainless Steel Impeller Wheels . . .

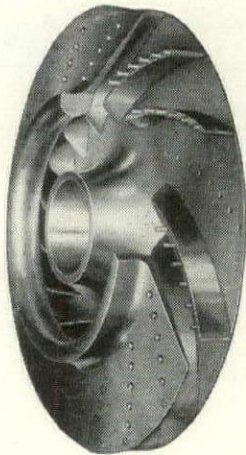

Available on no other compressor, yet they're standard equipment on York Turbos! Wheels constructed *entirely* of turbine quality stainless steel, corrosion-proof . . . and erosion resistant . . . assure years of operation at initial high efficiency.

ONLY YORK HAS

Pre-Rotation Vane Control . . .

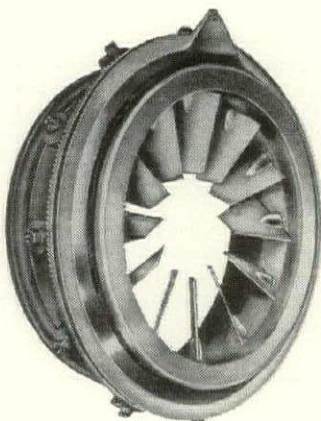

Exclusive with York, a *gradual acting* multi-radial vaned control, constructed of accurately machined non-ferrous materials. Ring and pinion gear movement insures smooth vane opening and closing—multiple vanes give *precise adjustment* of refrigerant flow down to minimum capacities . . . impart a *flow pre-rotation*. Result—inherent *stability of operation* over the widest capacity ranges.

York gives you these 2 exclusive features at no extra cost. They put the York Turbo in a class by itself!

YORK *Refrigeration and Air Conditioning*



HEADQUARTERS FOR MECHANICAL COOLING SINCE 1885

Lesson for Today—



—as taught by the
Brunswick Township
School Board



Right: Tightening the rigid bridging between the Junior Beams in the new Brunswick Township, Ohio, High School. Below: Architect's rendering of the new school, now under construction.

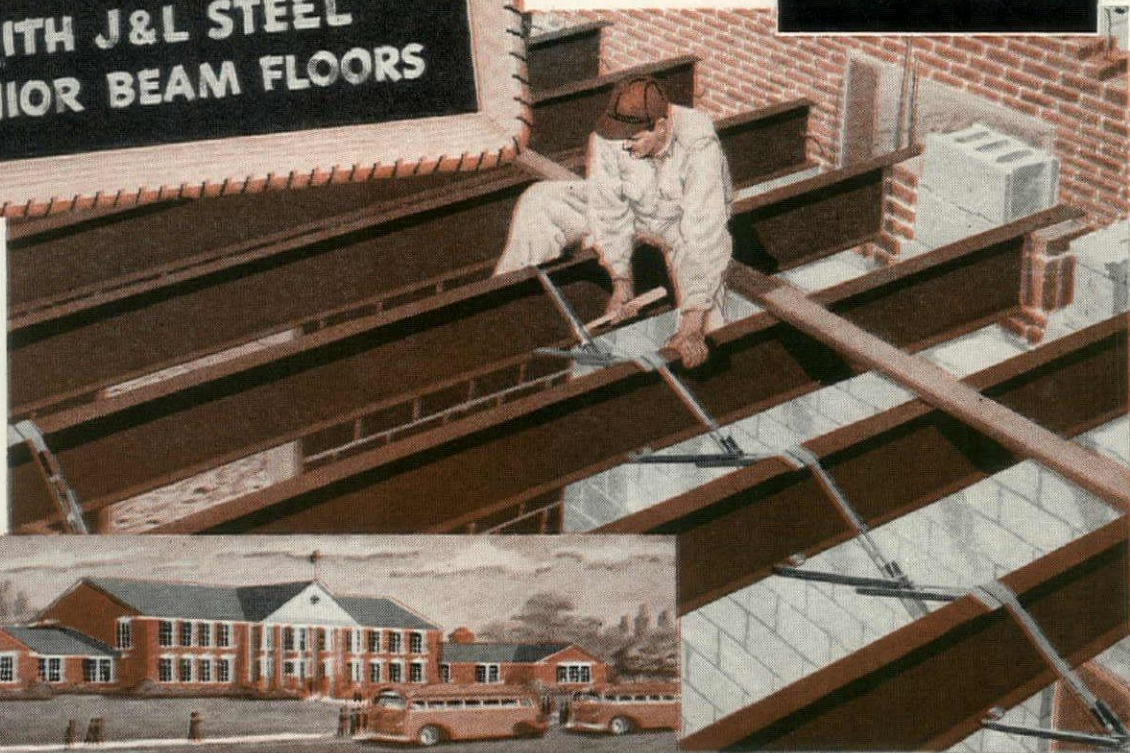

Contractor handles and places J&L Junior Beams without aid of mechanical hoist



The lesson that many school boards, contractors and architects are learning today, is that *steel and concrete floor construction with J&L Junior Beams saves time and money.* These beams cost less to buy, cost less to erect, yet for many types of "light" structures, they offer all the advantages of heavier structural members.

There are good, sound reasons for the trend to J&L Steel Junior Beams in

schools, apartments, residences and other light occupancy buildings.

Mr. H. Joseph Nitchman, of Berea, O., Architectural Engineer for the new Brunswick Township school, specified them because:—"Compared with heavier structurals, Junior Beams are well designed for this type of structure—also well designed for use with metal lath and paper-backed mesh."

Mr. C. E. Karn, of Unit-Way Homes, Inc., Berea, O., the contractor for this school, stated: "These beams require no special handling equipment. Four men without any equipment at all, raised the Junior Beams to the second floor and placed them properly. This is an important point on many jobs."

The Brunswick Township School Board likes J&L Junior Beam floor construction, because it is fire-proof, helps hold down construction and maintenance costs, and minimizes insurance rates.

School Boards! Architects! Contractors!

Check these advantages of J&L Steel Junior Beam Floors: Economical—Fire-proof—Rigid—Shrink-proof—Termite-proof—Easy to install—Low maintenance—Permanent.

J&L Junior Beams are available now through leading steel warehouses including J&L Service Warehouses at Chicago, Cincinnati, Detroit, Memphis, New Orleans, New York and Pittsburgh. Let us send you descriptive literature and engineering data. The coupon below is for your convenience.

Jones & Laughlin Steel Corporation
401 Jones & Laughlin Building
Pittsburgh 30, Penna.

Please send me complete data on J&L Junior Beams and Junior Beam Floors.

Name

Address

City Zone

State

JONES & LAUGHLIN STEEL CORPORATION
America's Only Producer of Steel Junior Beams

Wood treated with
pentachlorophenol

decay Protected WITH PENTACHLOROPHENOL termite

LASTS LONGER!

DOW
CHEMICALS INDISPENSABLE TO INDUSTRY AND AGRICULTURE

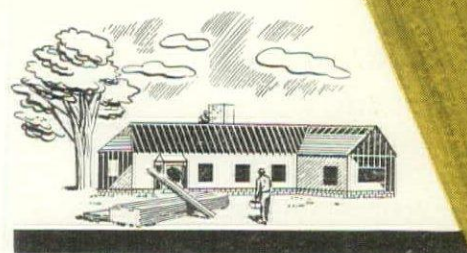

PENTACHLOROPHENOL not only cuts maintenance costs but makes possible new and effective uses for wood—wood that's protected from termites and decay when treated with PENTACHLOROPHENOL.

The increased durability PENTACHLOROPHENOL gives to wood is a challenge to the architect and builder to reinvestigate wood—an extremely versatile and economical material—and its almost infinite variety of applications.

Capitalize on the many unique qualities of wood and lower maintenance costs at the same time. Build with PENTACHLOROPHENOL-treated wood.

THE DOW CHEMICAL COMPANY
MIDLAND, MICHIGAN



GET THE FACTS!

Send today for complimentary booklet that tells the PENTACHLOROPHENOL story. Ask for booklet PE113.

one need hardly listen to hear assessment piling up in the night, the adobes tend to be rather roomy. Those that aren't look more as though they belonged near the railroad tracks in Altoona, Pa., than in sunny Calif. Genealogically, no other book on houses surpasses this one. M.S.

DESIGN IN CIVIL ARCHITECTURE. By A. E. Richardson and H. O. Corfiato. The English Universities Press. Ltd., St. Paul's House, Warwick Sq., London. 212 pp. Illus. 12½ x 10 L. 32/6.

To be quite clear, the title of this book should have been *Design in Civil Architecture of the Past* since it is purely retrospective work. It is nevertheless a fine, world wide collection set forth in simple line drawing. A few perspectives are included but by and large the book consists of elevations. The brevity of the accompanying comments indicates that the authors are addressing themselves to a practicing readership. They claim that the purpose of their book is to "provide ideas which will refresh the minds of architects and at the same time will avoid the danger of puerile copyism." The first clause is easy enough to grasp but the second becomes dubious after one has read the introductory remarks wherein a good many rigid, ultra-Beaux artish rules are laid down.

After an understandable dose of classicism the book eventually catches up with the Town Hall in Stockholm, the Naples Post Office, the Ministry of Education and Health Building in Rio, but the U. S. is represented by such edifices as the municipal building and university club in New York, a few town houses and a tired old Park Avenue apartment building. For the purpose of record the book has value since it includes the facades of many famous buildings destroyed in the last war. Architects, however, should use it for purposes of refreshment only. M.S.

HOUSES FOR THE PRAIRIE FARMER. The Planning Research Center. School of Architecture, University of Manitoba, Canada. 38 pp. Illus. 11 x 8¼.

Recognizing that most farm houses either are copies of houses built in town or inferior developments from one-room shelters, three Canadian provinces have set out to improve farm house design. The Prairie Rural Housing Committee sponsored by the Provinces of Manitoba, Saskatchewan and Alberta and by the Central Mortgage & Housing Corp., offers farmers, at the blueprinting cost of \$2.50, any one of ten excellent farm house plans. These are presented in the form of a free-on-request booklet containing, besides preliminary plans of all ten, much sound advice on planning the whole farmstead. The plans, sensibly, are not offered as cure-alls. Each house was designed for a hypothetical family, the size, interests, work and relaxation habits of which were assumed. However, the committee feels the plans will serve as guides and in some cases prove almost tailor-made.

The houses, designed by The Planning Research Center of the School of Architecture at the University of Manitoba, have open plans. All have combination rooms of one kind or another for flexibility. Orientation to prevailing breezes and to the sun is considered in each case and, while a trifle tight in concept, most of the houses seem quite pleasant. If these are samples of what may be expected from Canada's future house architects, the complexion of "Canadian Homes and Gardens" is due to change.

(Continued on page 184)

YESTERDAY



... and

Today

Remember the old open-top "double-deckers" that honked their way down New York's Fifth Avenue? Can you recall the "brownstones" and the lofts that gave way to the breathtaking grandeur of modern skyscrapers like world-famous Rockefeller Center?

Back in the "teeming twenties" a new era in building was begun—an age when skyscrapers rose higher and higher—when vertical transportation became as important to business as the railroad and the automobile.

It was then that Westinghouse moved in with its vast electrical know-how and, in the years since then, has given the elevator industry the major improvements that have promoted more profitable operation of modern buildings.

For example, variable voltage control developed by Westinghouse made possible the high speed elevators in such landmarks as Radio City. Rototrol, a great

Westinghouse development, added new ease and comfort to elevator travel. Westinghouse inductor landing made elevator travel safer.

Then came Selectomatic*, offered only by Westinghouse, to lift multi-car operation to a peak of efficiency still unmatched. And now—Westinghouse has introduced the first high-quality, lower-priced electric stairway to open up new sales opportunities to retail stores.

These and many other Westinghouse developments have led elevator progress. That's why today, the name Westinghouse means the *finest* and *most advanced* in modern elevators and electric stairways.

Westinghouse

ELEVATOR DIVISION



Trademark

J-98515

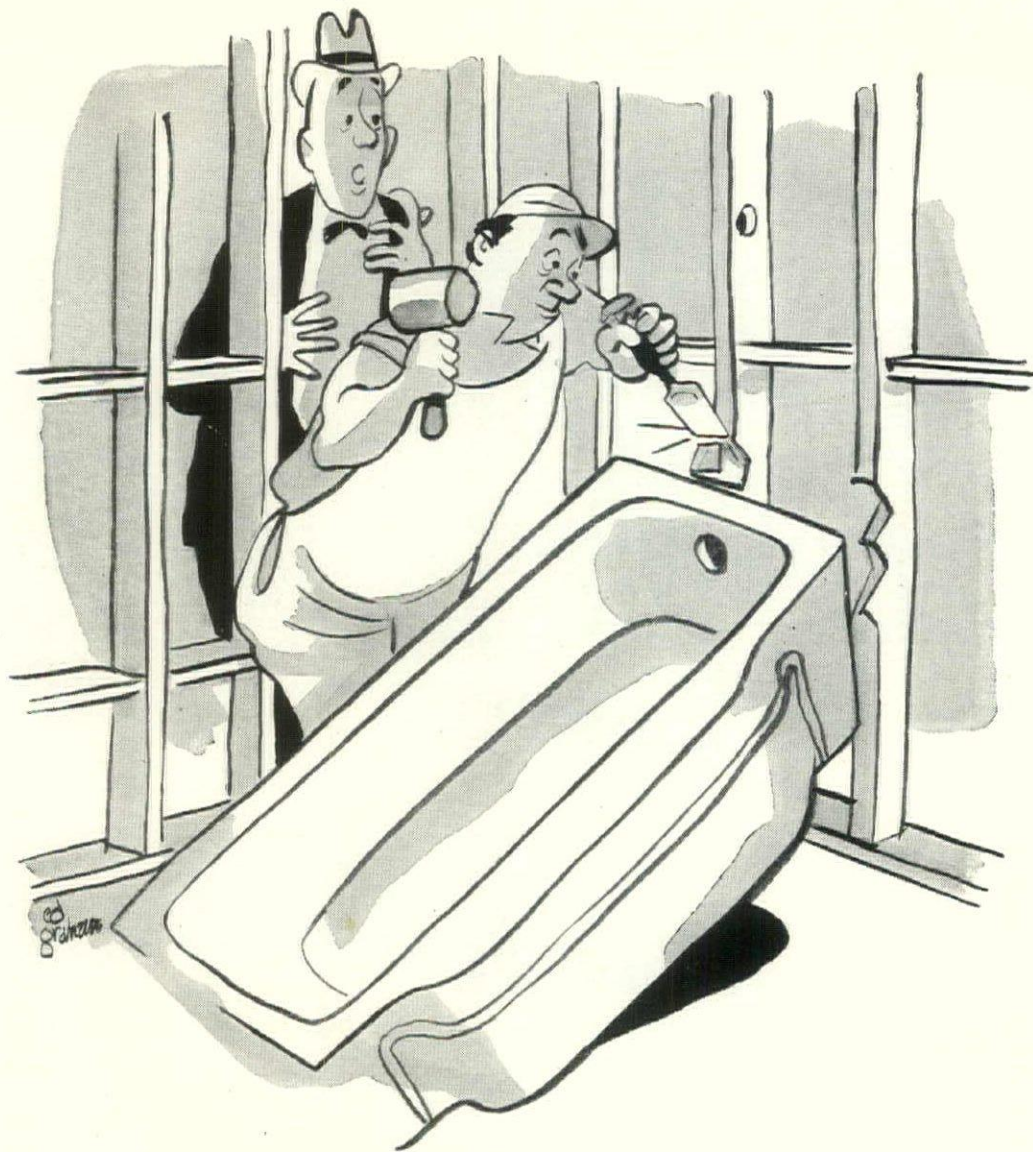

Don't have a fit... have a perfect fit with BRIGGS!

COPYRIGHT 1948, BRIGGS MANUFACTURING CO.

This crisis could never come about on a Briggs Beautyware installation. All goes smoothly when you're handling this modern die-formed *steel* bathtub for, when you specify a 5' Briggs tub, you can be sure it is exactly 60" long. Briggs is the bathtub that eliminates the problem of leaks at tub-wall line (integral lip flange makes it leakproof) . . . and banishes the labor of lifting (weighs only 110 pounds). It's the tub that's furnished in luxurious stainproof (acid resistant) porcelain enamel at no *extra cost!* That tells you why Briggs Beautyware—with its top quality, moderate price, and revolutionary features—is today's best buy in plumbing fixtures. Write *now* for new catalog featuring Briggs plumbing fixtures and Briggs brass. Briggs Manufacturing Co., 3023J Miller Ave., Detroit 11, Michigan.

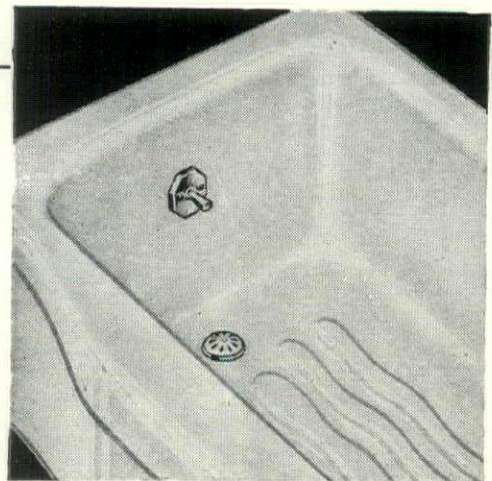

BRIGGS *Beautyware*

Briggs Beautyware bathtub is exact in dimensions—die-formed and engineered to permit easy installation. If it's Briggs, it fits! Notice the patented Safety-Bottom, another great Briggs exclusive.

ALWAYS A GOOD PLAN—turn to Wheeling

During the past 58 years, thousands of builders have learned it pays to back up good workmanship with materials bearing the famous Wheeling Red Label. These products are known most everywhere for quality and can give you outstanding value—economically, satisfactorily.

WHEELING METAL LATH

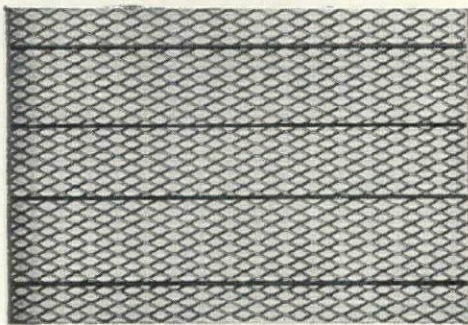

BAR-X-LATH

Saves time and plaster. Sheets have "stiff beam" reinforcement with four pairs solid, crush-proof rods welded to the mesh. Result: Minimized sagging. No stretching. Easy, fast handling.

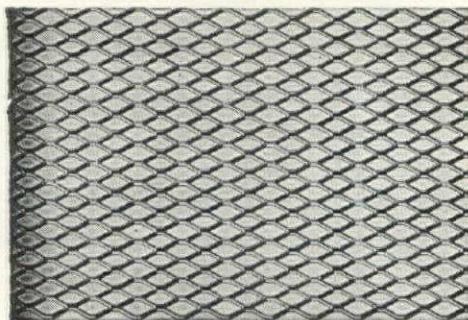

DIAMOND LATH

Stiffest of its type. Flat sheets with perfectly straight, parallel sides promote easy, fast installation.

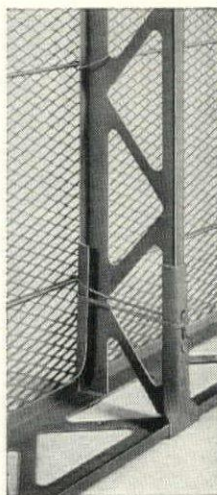

WHEELING BAR-Z PARTITIONS

For quick assembly into non-bearing hollow plastered steel stud and metal lath partitions, or free standing wall furring, from few unit parts.



WHEELING TRI-RIB ROOF DECK

Assembles over four supports as a continuous beam. Cop-R-Loy Steel resists rust, corrosion. Goes on fast at low cost. Lengths up to 22' 6". A solid base for any insulated type roofing.



WHEELING FLEXBEAD

Steel corner prevents plaster damage. Gives rigid straight edge to guide workmen. Can be easily adapted to arch work.

**WHEELING CORRUGATING COMPANY
WHEELING, WEST VIRGINIA**

Atlanta • Boston • Buffalo • Chicago • Cleveland • Columbus • Detroit • Kansas City
Louisville • Minneapolis • New Orleans • New York • Philadelphia • Pittsburgh • Richmond • St. Louis

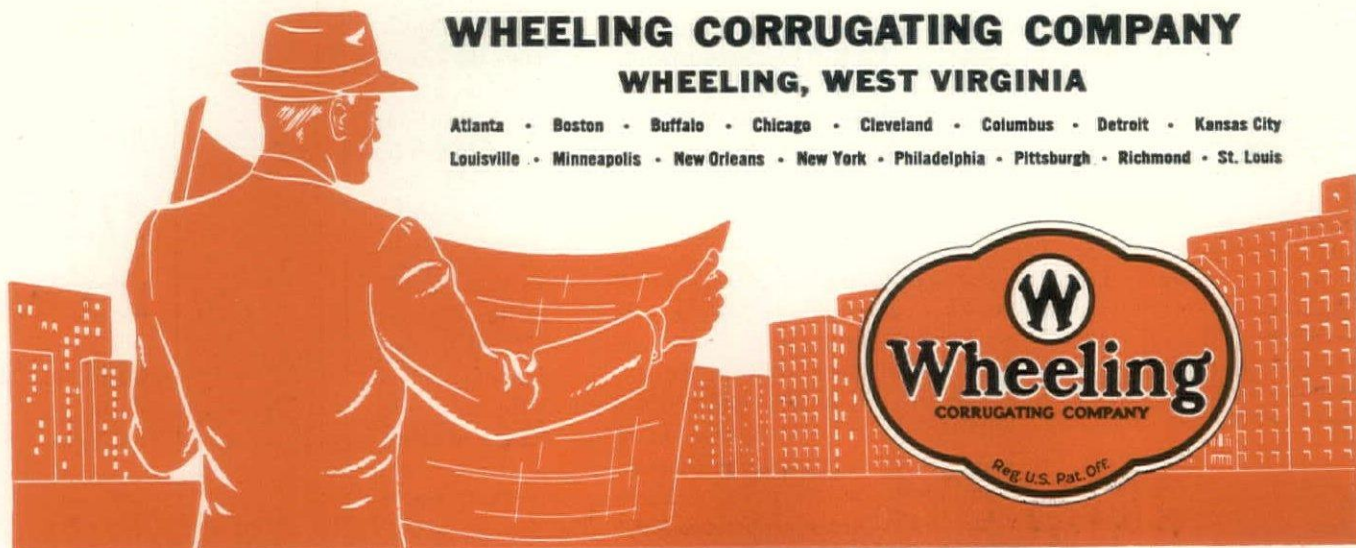

REVIEWS

An announcement

The Allmetal Weatherstrip Company, manufacturers of quality weatherstrip equipment since 1915 announces a NEW and SUPERIOR patented Sash Balance and Weatherstrip Unit.

Details are shown below.

Here are the features . . .

- 1 Balancing equipment for double-hung sash has always emphasized sash suspension. The Allmetal Unit is engineered to counter-balance sash in two ways; with coil spring tension to overcome gravity and metal housing tension to provide stability. Note that the tubular housing which covers the spring is a free-moving member. Under easy compression in the sash groove it offers maximum surface contact with the wood yet maintains free contact movement.
- 2 Spring is enclosed and invisible.
- 3 Effective weather protection for the runways is assured with flexible hemmed side rib.
- 4 Non-corrosive and rust-proofed metal construction throughout.

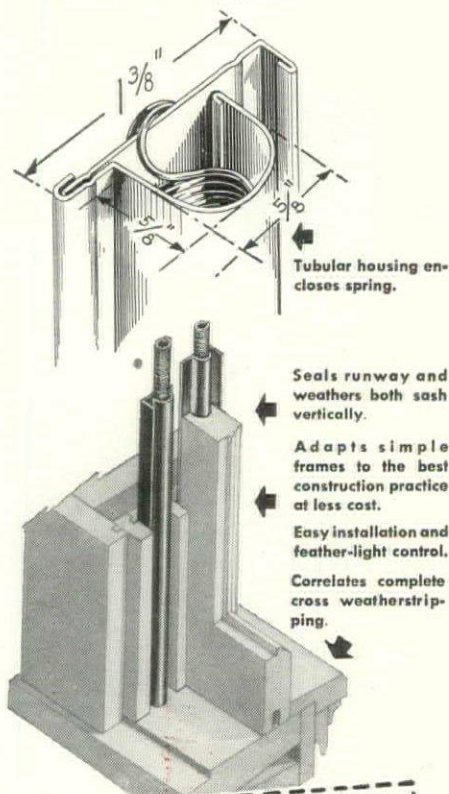

Tubular housing encloses spring.

Seals runway and weathers both sash vertically.

Adapts simple frames to the best construction practice at less cost.

Easy installation and feather-light control.

Correlates complete cross weatherstripping.

ALLMETAL WEATHERSTRIP CO.
2239 N. Knox Avenue, Chicago 39, Illinois

Gentlemen: Please send me complete information and prices.

Name _____

Address _____

Town _____

THE ALLMETAL SASH BALANCE & WEATHERSTRIP UNIT

The designers have included two one-story expandable houses. One (the smallest of the ten) grows from 624 sq. ft. to 960 sq. ft.; the other (the largest) from 1,392 sq. ft. to 1,482 sq. ft. Of the remaining eight, five are one story, four have two floors. Basement plans are included for all ten but it is explained that this is optional, depending upon family requirements. W.W.A.

PUBLIC HEALTH ENGINEERING. Vol. 1. By Earle B. Phelps and collaborating authors. John Wiley & Sons. New York. 1948. 655 pages. Illus. 5 1/2 x 8 1/2. \$7.50.

Many an architect and builder will find this book extremely handy as a reference. In it Mr. Phelps has set forth for the public health engineer, the latest data on man as he relates to his natural and artificial environment. Part I is titled The Air Contact. Here the author discusses heating ventilation, air conditioning, lighting, atmospheric pollution and noise.

It is undoubtedly this first section that will prove most valuable to the average architect and builder. The background of heating, ventilating and air conditioning is simply reviewed and in addition Mr. Phelps has included valuable tables, graphs and formulae used by the engineer to determine optimum conditions of health and comfort. The practical application of theory is then discussed and additional tables and formulae are included for the conditioning of various kinds of spaces. The author also manages to include descriptions of the instruments used for measuring the thermal environment. Following chapters carry through the same processes for lighting, atmospheric pollution, and noise.

One of the collaborating authors, Harry D. Pratt, Scientist for the U. S. Public Health Service, has also written a chapter on insects and their controls. After a nod to such well-known pests as flies, mosquitoes, lice, fleas and ticks, we find listed the cone-headed bug which, the author blandly states, is responsible for Chagas disease. In the discussion on body lice it is also interesting, if not particularly instructive, to note that they are often called seam squirrels because of their habit of cementing eggs in the seams of clothing. The life cycle and habits of the various pests are presented at length and controls are exhaustively explored, ranging from household sprays to drainage ditches, with their advantages and disadvantages in various applications.

Part II, The Water Contact, will be helpful to any one who has to contend with water supplies and sewage disposal problems. The first chapter defines and explains the science of hydrology. Following chapters discuss in detail the quality of water, the water supply, treatment of polluted waters and rural sanitation. Here, as in Part I, Mr. Phelps begins with the principles and carries through to practical applications. Graphs, charts, tables and formulae give most of the information required for safe design of water and sewage systems.

Mr. Phelps, in the author's preface, states that "Public Health Engineering" is "written primarily for the engineer who presumably has learned how to design and build, to teach him, in the light of present-day knowledge of sanitary science, what to design and build and why." He has accomplished this purpose admirably. In addition, as stated above, he has produced a book which many architects, builders and others, who are not public health engineers, will find a valuable work for the reference shelf. The present work is Volume I, incidentally, of a two volume series. W.W.A.

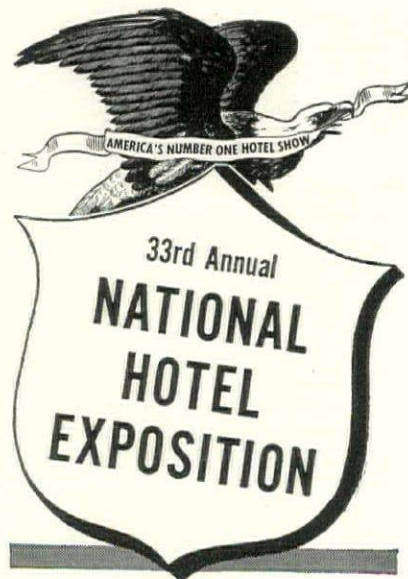

NOVEMBER 8-12
Grand Central Palace
NEW YORK
Dean Carpenter, Chairman

Four fully-packed floors of interesting exhibits . . . a rare opportunity to keep up with the latest developments in the operating technique of hotels, restaurants, clubs, hospitals, institutions, transportation lines and allied interests.

REGISTER NOW. Be sure to include position and business connection. An invitation will be mailed to you. No registration fee.
Address Arthur L. Lee, General Manager
221 West 57th St., New York 19, N. Y.

ADVERTISED IN
LIFE

. . . means news
of famous
products to
27,500,000
LIFE readers
each week

for better fluorescent lighting



• When you demand and insist on Certified Ballasts in fluorescent lighting fixtures—you're protecting your own best interests—as well as the users'.

Everyone benefits by using Certified Ballasts because they assure . . .

Full lamp life
Quiet operation

Rated light output
Dependable performance for fixture life

Strict specifications control the building of every Certified Ballast—Electrical Testing Laboratories, Inc., an impartial judge, then checks and tests them. You're surer of satisfaction with Certified Ballasts.

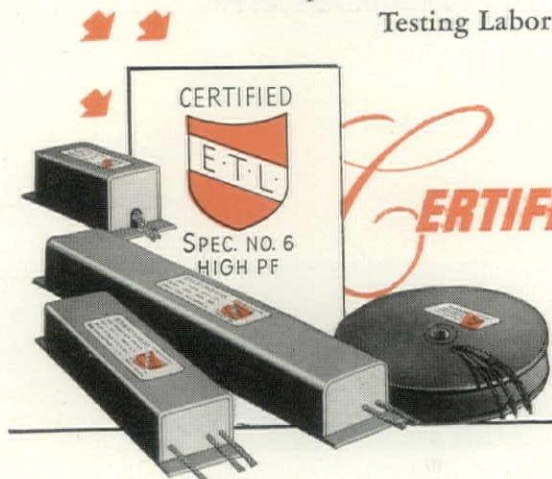

CERTIFIED BALLAST MANUFACTURERS

Makers of Certified Ballasts for Fluorescent Lighting

2116 KEITH BLDG., CLEVELAND 15, OHIO

New reference manual on

INSULATED ROOFS

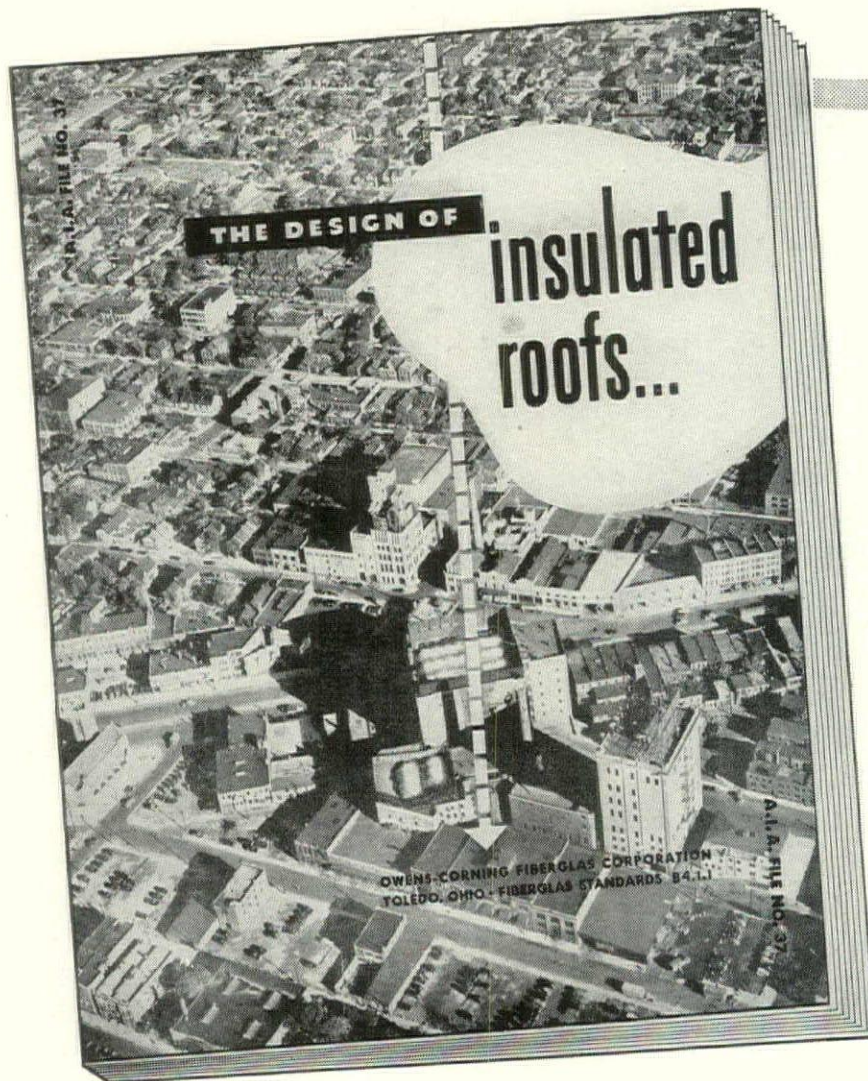

"The Design of Insulated Roofs", just off the press, incorporates the very latest information on the design of roof structures in relation to external exposures and internal heating and cooling loads.

It contributes technically sound, new data which may influence your design practices.

Not merely a catalog, this 36-page reading and reference manual contains a wealth of valuable material and is, we believe, the first volume of its kind in the field.

If you have not received your copy, write on your letterhead to Owens-Corning Fiberglas Corporation, Dept. 830, Toledo 1, O.

A. I. A. FILE NO. 37

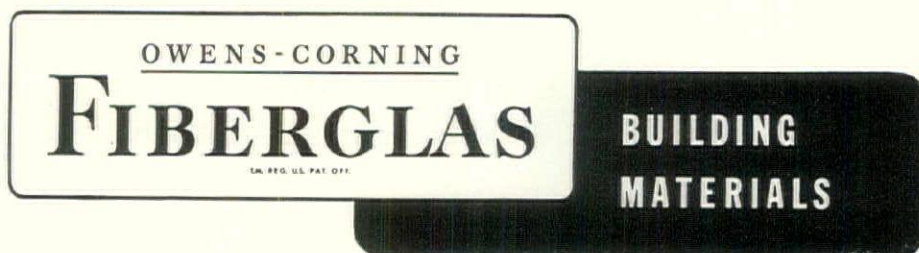

*FIBERGLAS is the trade-mark (Reg. U. S. Pat. Off.) for a variety of products made of or with glass fibers by Owens-Corning Fiberglas Corporation.

Whata Line*

The Line that's NEW . . . it's the completely new line of "Dutch Boy" Blended Paints!
 The Line for YOU . . . In Colors or White . . . It's Blended Just Right . . . To STAY Sparkling Bright!
 Each is a real "Dutch Boy" paint . . . specially blended to do its job especially well. Each is the result of over 30 years of continuous outdoor paint tests!



1. Blended Bright WHITE Stays White! "Dutch Boy" Bright White is self-cleaning! The surface continually renews itself . . . permits rain to wash away dirt. Sets a new standard for hiding and for a dazzling white finish that stays white!



2. Blended TINTS Stay Fresh! "Dutch Boy" Tints go on crisp and fresh . . . and they go on staying crisp and fresh. Specially blended to assure lasting, uniform color!



3. Blended TRIM COLORS Stay Bright! "Dutch Boy" Sash & Trim Colors add the finishing touch to a home's protection. They're blended to hold their brilliant gloss . . . to stay bright and gay!



4. Blended PRIMER Seals, Hides and Holds! An undercoat of great sealing and hiding power that holds fast. Used under "Dutch Boy" Bright White or Tints, it gives a superior 2-coat job, even on unpainted wood!



5. Blended PORCH & DECK PAINT Stands Wear! "Dutch Boy" Porch & Deck Paint is blended to stand up under the kicking around this type of paint gets from foot traffic and weather!



The New Line of

"DUTCH BOY" BLENDED PAINT

NATIONAL LEAD COMPANY: New York 6; Buffalo 3; Chicago 8; Cincinnati 3; Cleveland 13; Pittsburgh 12; St. Louis 1; San Francisco 10; Boston 6 (National Lead Co. of Mass.); Philadelphia 7 (John T. Lewis & Bros. Co.).

Made by the Makers of the Famous "Dutch Boy" White Lead



And what an INTERIOR PAINT!

Never Before . . . a one-coat, inside paint that really covers in one coat . . . yet really washes like new! It's the new "Dutch Boy WONSOVER!"

Never Before such covering power in a real oil flat paint! Once over and the work's over with "WONSOVER!"

Never Before such an easy-to-clean one-coat paint as "WONSOVER!" Stains, even ink, don't sink in, so they wash right off!
 The colors? Fresh tints, soft shades, modern, deep tones and white white!

"Dutch Boy" WONSOVER

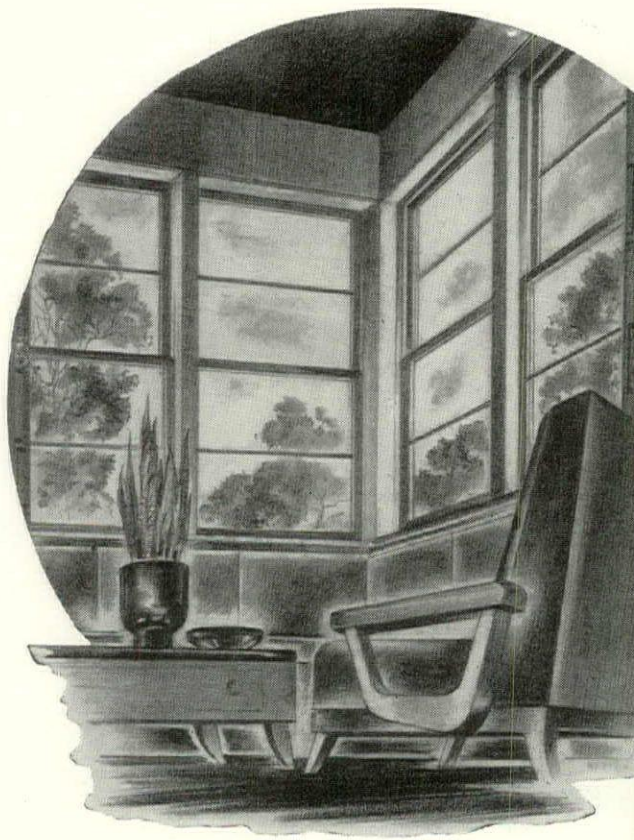

Remember . . . there is only one

Unique

SASH BALANCE

Windows equipped with Unique Sash Balances operate with utmost satisfaction because of the perfect spring control.

This exclusive patented feature controls the increase and decrease of the spring power and results in a perfectly balanced window at all points.

This is only one of the many features of Unique Sash Balances. Write today for further information.

UNIQUE BALANCE COMPANY, INC.
25 Bruckner Boulevard, New York 54, N. Y.



Unique Sash Balance plants are located in the United States, Canada, Australia, and in England to fill a worldwide demand.

Unique

The Sash Balance with an accelerated spiral rod, that insures perfect counterbalancing.

Perfect spring control. As the spring turns its tension changes. This change is accurately and automatically compensated for by the variable pitch of the spiral rod sliding through the slotted bushing fastened to the end of the spring.

80°

30°



"I'll play these"



Fleur-O-Lier fixtures are made by 26* leading manufacturers. They are built to detailed and rigid specifications. They are examined by Electrical Testing Laboratories, Inc., and *Certified* as to compliance with specifications. Adequate samples constantly are reexamined to be certain that high quality is maintained.

That's why we say, "The Fleur-O-Lier label on a lighting fixture is your protection . . . your assurance of customer satisfaction."

*Participation in Fleur-O-Lier is open to any manufacturer wishing to qualify. Consequently, the number of Fleur-O-Lier manufacturers is increasing constantly.

FLEUR-O-LIER

Manufacturers

2116 Keith Building • Cleveland 15, Ohio

Fleur-O-Lier is not the name of an individual manufacturer, but of a group of fixtures made by leading manufacturers. Participation in the Fleur-O-Lier program is open to any manufacturer who complies with Fleur-O-Lier requirements.

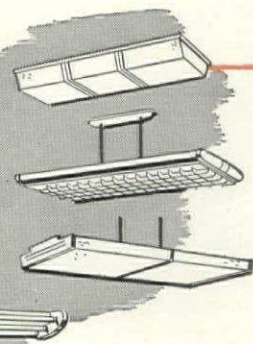

SPECIFICATION AND BUYING INDEX

The advertising pages of FORUM are the recognized market place for those engaged in building. A house or any building could be built completely of products advertised in THE FORUM. While it is not possible to certify building products, it is possible to open these pages only to those manufacturers whose reputation merits confidence. This THE FORUM does.

Adams and Westlake Company, The	121
All Metal Weatherstrip Co.	184
Aluminum Company of America (Alcoa)	31, 151
Aluminum Window Manufacturers Association	142, 143
American Radiator & Standard Sanitary Corporation	155
American Structural Products Company	146
Andersen Corporation	117
Anthracite Institute	8, 9
Architectural Forum, The	Opp. 141
Asbestone Corporation	136
Automatic Products Co.	30
Bakelite Corporation	160
Bigelow-Sanford Carpet Company, Inc.	174
Briggs Manufacturing Company	182
Bruce, E. L., Company	25
BullDog Electric Products Company	149
Cambridge Tile Manufacturing Company, The	Cover II
Carr, Adams & Collier Company, Inc.	133
Carrier Corporation	Opp. 140
Case, W. A., & Son Mfg. Co.	65
Ceco Steel Products Corporation	114, 115
Celotex Corporation, The	2
Certified Ballast Manufacturers (Equipment)	185
Chicopee Manufacturing Corporation	172
Clayton & Lambert Manufacturing Company	156
Coleman Company, Inc., The	173
Connor, W. B., Engineering Corporation	130
Continental Radiant Glass Heating Corp.	41
Cork Insulation Company	148
Couch, S. H., Company, Inc.	64
Cribben & Sexton Co.	38
Curtis Companies	177
Deco Plastics Inc.	1
Detroit Steel Products Company	4, 5
Devoe & Reynolds Company, Inc.	20
Div-Rack Corporation	44
Dole Valve Company	22
Dow Chemical Company, The	180
Dunbar Furniture Manufacturing Company	62
Dunham, C. A., Company	64
Dwyer Products Corporation	124
Eagle Industries, Inc.	24
Eagle-Picher Company, The	56
Eljer Company	192, Cover III
Emerson Electric Manufacturing Company, The	60
Facing Tile Institute	57
Fedders-Quigan Corporation	44
Federal Enterprises, Inc.	161
Fiat Metal Manufacturing Company	140
Fleur-O-Lier Manufacturers	189
Flintkote Company, The	Opp. 69
Flynn, Michael, Manufacturing Company	35
Formica Insulation Co., The	157
Frigidaire Division (General Motors Corporation)	147
General Electric Company	37, 55, 123, 170
General Motors Corporation (Frigidaire Division)	147
Goodyear Tire & Rubber Co.	23
Graybar Electric Co.	152
Hall-Mack Company	30
Hamilton Mfg. Co.	54
Haskelite Mfg. Corporation	48
Hunter Douglas Corporation	18
ILG Electric Ventilating Company	176
Inland Steel Products Company	135
Insulite Company, The	17
International Business Machines Corporation	127
Jackson & Church Company	52
Johns-Manville	50, 51
Jones & Laughlin Steel Corporation	179

Kelvinator	1
Kennedy, David E., Inc.	Opp.
Kewanee Boiler Corporation	1
Keystone Steel & Wire Company	1
Koppers Company	1
Leader Electric Manufacturing Corporation	1
Libbey-Owens-Ford Glass Company	1
Lorentzen Hardware Mfg. Corp.	1
Louisville Cement & Wire Co., Inc.	1
Lustron Corporation	6
Marble Institute of America, Inc., The	15
McKinney Mfg. Co.	3
Meyer Furnace Company, The	2
Miller, Herman, Furniture Company	2
Monroe, Lederer & Taussig, Inc.	15
National Adequate Wiring Bureau	5
National Electric Manufacturers Association	144, 14
National Gypsum Company	12
National Hotel Exposition	18
National Lead Company	18
National Oak Flooring Manufacturers' Association	12
Nichols Wire & Aluminum Company	16
O'Brien Corporation, The	16
Otis Elevator Company	16
Overhead Door Corporation	Cover I
Owens-Corning Fiberglas Corporation	39, 18
Paine Lumber Co.	3
Paraffine Companies, Inc., The	15
Penberthy Injector Company	3
Permanente Products Company	13
Pittsburgh Corning Corporation	11
Pittsburgh Plate Glass Company	4
Ponderosa Pine Woodwork	13
Pratt & Lambert, Inc.	12
Pryne & Company, Inc.	3
Raymond Concrete Pile Company	17
Revere Copper and Brass, Inc.	164, 16
Reynolds Metals Company	169
Richards-Wilcox Manufacturing Company	168
Roddis Lumber & Veneer Company	61
Rohm & Haas Company	19
Rowe Manufacturing Company	113
Russell, F. C., Company, The	38
Sargent & Company	118
Servel, Inc.	66, 67
Sonneborn, L., Sons, Inc.	34
Soss Mfg. Co.	40
Speakman Company	46
Square D Company	27
Staedtler, J. S., Inc.	20
Structural Clay Products Institute	122
Superior Electric Company, The	63
Timken Silent Automatic Division (The Timken-Detroit Axle Co.)	191
Trane Company, The	58
Tuttle & Bailey, Inc.	68
Unique Window Balance Co.	188
United States Gypsum Co.	59
United States Plywood Corporation	131, bet. 140 & 141
United Wallpaper, Inc.	132
Vikon Tile Co.	120
Walworth Company	134
Ware Laboratories, Inc.	32, 150
Wasco Flashing Company	150
Waterfilm Boilers, Inc.	36
Webster, Warren, & Company	62
Welbilt Stove Company, Inc.	40
Western Electric	137
Westinghouse Electric Corporation	42, 43, 181
Wheeling Corrugating Company	183
Yale & Towne Manufacturing Company, The	171
York Corporation	178

Duty-Designed

AUTOMATIC HEATING EQUIPMENT FOR SMALL HOMES by Timken Silent Automatic

Announcing
Two Extraordinarily Efficient
Heating Units

For Warm Air Heating and
Winter Air Conditioning—

THE HI-FURNACE

Designed specifically to provide small homes with a completely modern heating package, this new Timken Silent Automatic unit combines a wall-flame oil burner, furnace with radiator, blower, air filters and automatic humidifier (extra optional equipment), all in one fully-integrated, super-efficient unit.



The Same Amazing Wall-Flame Oil Burner Fires Them Both

Completely quiet and completely dependable, the famous Timken Silent Automatic Wall-Flame Oil Burner consistently saves up to 25% or more on fuel oil bills. The wall-blanketing wall-flame gives faster, more uniform heat, too.



For Hot Water Heating, Radiator
and Radiant Systems—

THE HI-BOILER

The full benefits of modern automatic heating—plus fully automatic domestic hot water—are introduced into even the smallest homes by this remarkable unit. The single, space-conserving cabinet contains a wall-flame oil burner, heating boiler, domestic water heater, expansion tank and complete wiring and control system.

When it comes to heating small homes, your top-profit choice is Timken Silent Automatic! Here's a line of modern, automatic heating equipment that's Duty-Designed to give you an unmatched sales advantage in the biggest-profit market of them all—the small home!

There's not an oil burner built that can approach the Timken Silent Automatic Wall-Flame Burner for its combination of

economy, quietness and freedom from trouble. Now this best-liked, best-built burner is available in Duty-Designed models—especially designed for every type of small home.

What's more, this sales-speeding equipment is *competitively priced!* If you want your new homes to move quickly—without paying a price premium—get in touch with your local Timken Silent Automatic Dealer *today!*

TIMKEN Silent Automatic OIL HEAT

TIMKEN SILENT AUTOMATIC DIVISION
The Timken-Detroit Axle Company • Jackson, Michigan



OTHER UNITS IN THE FAMOUS TIMKEN SILENT AUTOMATIC LINE

OIL FURNACES



Timken Silent Automatic Oil Furnaces for larger homes give you modern winter air conditioning at its economical best. They heat, humidify, filter and circulate the air for perfect comfort always. The fuel-saving wall-flame oil burner is the heart of these units.

OIL BOILERS



Experience-designed and quality-built, the great Timken Silent Automatic Oil Boilers are unexcelled for long life—unrivaled for low-cost operation. No other comparable unit offers so many features for quiet, clean, long-lasting satisfaction.

WATER HEATERS



Here's an abundance of hot water for showers, laundry, dishes, cleaning—at only a few cents a day! Timken Silent Automatic Water Heaters, both coil type and tank type shown, come with the wall-flame oil burner.



Architects:

ELJER

GIVES YOU A SIZE, TYPE AND DESIGN
OF PLUMBING FIXTURE FOR EVERY JOB

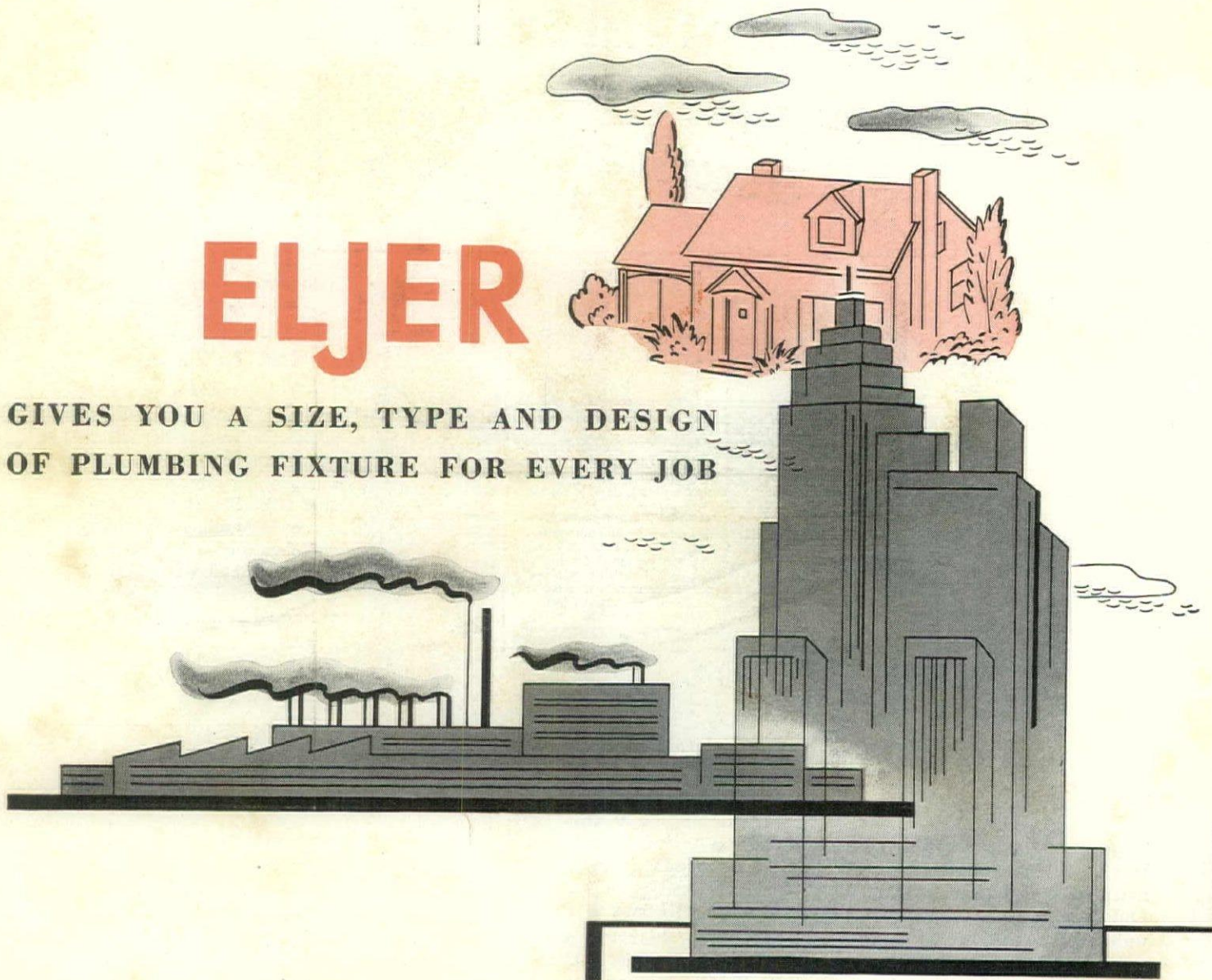

AS ADVERTISED IN THE POST: Eljer advertising in consumer magazines like The Saturday Evening Post will reach more than 75,000,000 people in 1948. Everywhere, more and more people appreciate the long-life styling, extra conveniences and superb craftsmanship of Eljer's Fine Plumbing Fixtures, trimmed with Eljer's Quality Brass.



It pays you, it pays us- because we specialize in Plumbing Fixtures and Brass

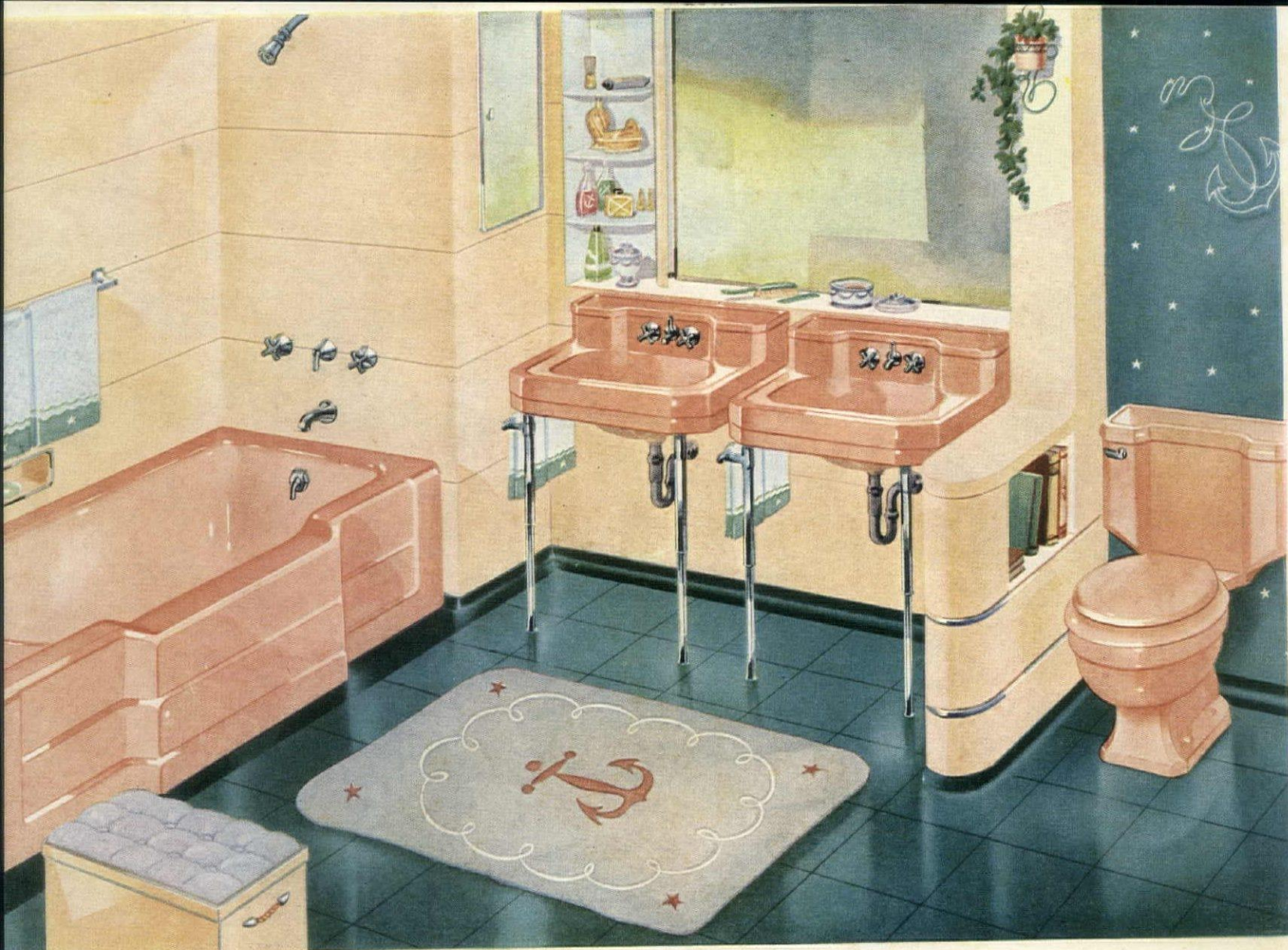

AN ELJER BATHROOM... *that New look!*

Eljer bathroom fixtures have just about everything: that perpetually new look, plus design and color, and besides they can be kept bright and shiny with the swish of a damp cloth.

The gleaming surfaces of Eljer plumbing fixtures, like their beauty and design, are the result of nearly half a century of continuous research and manufacturing ingenuity. All Eljer bathtubs have a heavy layer of lustrous enamel fused on a rugged, rigid, cast-iron base. Over 10 million Eljer fixtures are in use today.

The twin arrangement of vitreous china lavatories

shown above is a grand idea for a busy household. But whatever your idea is, Eljer's wide line of harmonious styles and colors will help you achieve it.

Select the exact Eljer bathroom, kitchen or laundry combination you would like; talk it over with your plumbing contractor. Write for our free booklet "Fixtures of Beauty and Distinction". Eljer Co., General Offices, Ford City, Pa.

• Eljer faucets turn off and on with a touch of the finger... thanks to new, exclusive construction. Avoid the annoyance of dripping faucets. Eljer fittings are another reason for always specifying Eljer fixtures.

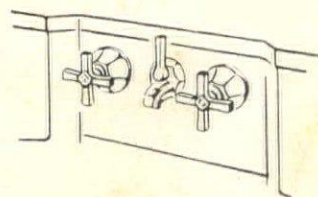

MANUFACTURERS OF FINE PLUMBING FIXTURES SINCE 1904

ELJER

Factories at Ford City, Pa., Salem, Ohio and Los Angeles
There are over Ten Million Eljer Fixtures in Use

May 27 45

Sound construction

also in stacks

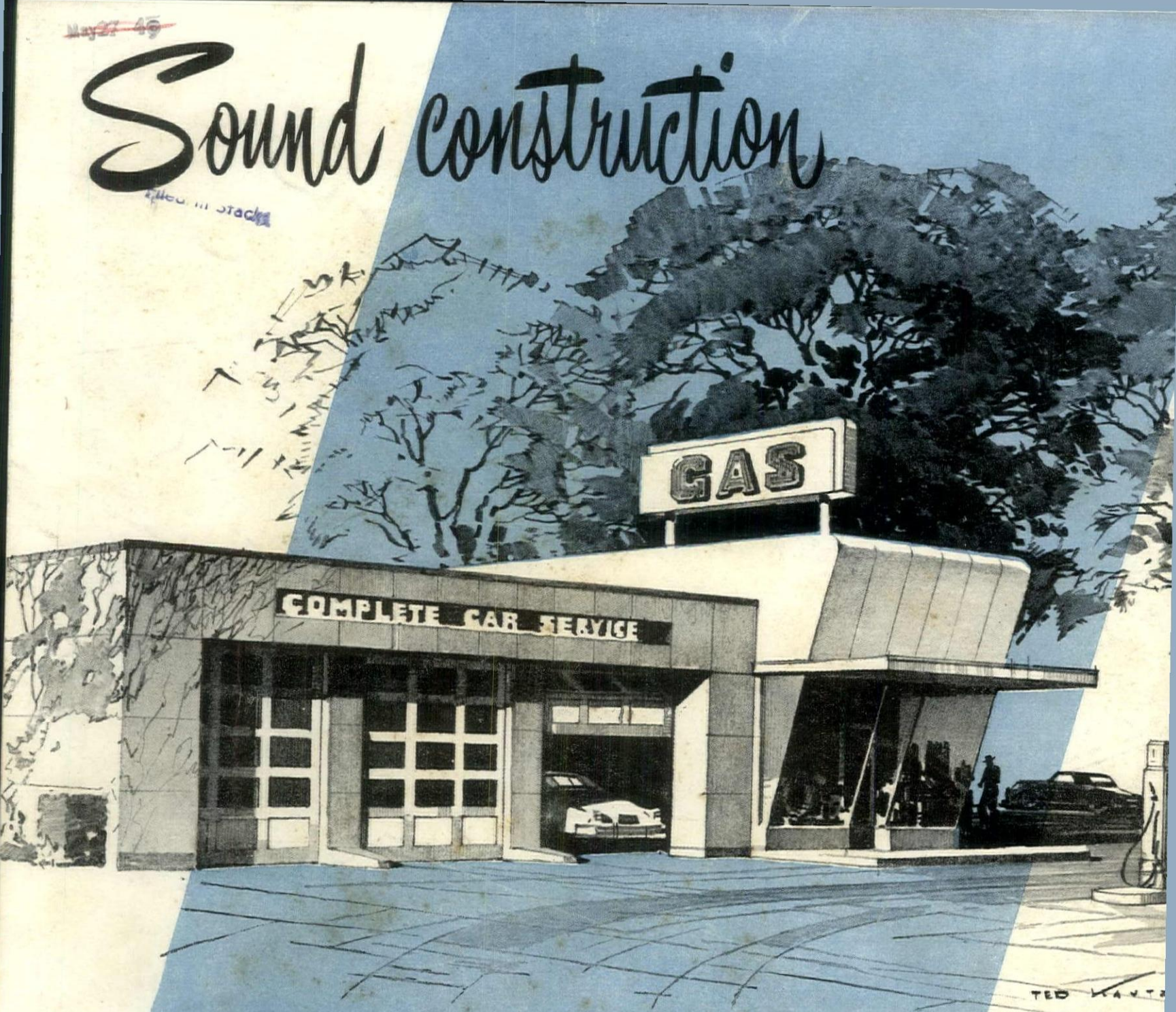

TED WALTER

Copyright, 1948, Overhead Door Corp.

... UNINTERRUPTED SERVICE

● The "OVERHEAD DOOR" with the Miracle Wedge is specified for commercial, industrial and residential structures by millions of users because of its sound construction and uninterrupted service. Any "OVERHEAD DOOR" may be manually or electrically operated with instant, dependable performance insured. The Miracle Wedge provides ideal opening and closing action. The door lifts upward and rolls back out of the way on full-floating, ball bearing rollers. It descends to wedge tightly against casing and header. Weathertight closure and fast, easy operation are assured by this quality door.

TRACKS AND HARDWARE OF SALT SPRAY STEEL



NATION-WIDE
SALES
INSTALLATION
SERVICE

OVERHEAD DOOR CORPORATION ● Hartford City, Indiana, U. S. A.