

\$2. a copy

JANUARY 1951

ARCHITECTURAL FORUM

THE MAGAZINE OF BUILDING



4096-685
549-9604

Radiant, Rugged, Real clay *Suntile*

puts a new "3R's" in schools



Beautiful, hard, strongly resistant to wear, easy-to-clean Suntile CAMARGOS in Christ the King School, Dallas. Architect: Edward J. Schulte, Cincinnati. Assoc. Arch.: M. C. Kleuser, Dallas. Gen'l Contractor: Cowdin Bros., Dallas.

Here's a new "3 R's" your clients are always pleased to learn about—"3 R's" that will teach them valuable lessons about lasting beauty and economy in school interiors.

The subject is not complicated. You simply insist on these "3 R's" when you're choosing tile:

Radiant: beauty-bright Color-Balanced Suntile makes it wonderfully easy to achieve the exact color effects desired for every part of the school. There's a rainbow's range of harmonious colors to choose from—radiant colors, soft, subdued colors, colors that improve lighting and aid vision, colors you can get only with Suntile.

Rugged: hard wearing Suntile gives you walls and floors with a fadeless, stainless finish. You can put Suntile in classrooms, corridors, cafeterias—any place where there's heavy traffic and hard wear. *A stroke of a damp cloth is all the maintenance required to keep it clean.*

Real clay: this is the reason for Suntile's beauty and durability. These qualities are *fired in . . . permanently.*

Suntile carries this quality right through to the guaranteed installation, too. Every job is performed by an Authorized Suntile Dealer, a craftsman who's been specially trained to give you those "3 R's" every time. He can be a big help to you in planning almost any kind of interior. Why not call on him now? See your classified telephone directory, or write us for his name. We shall be happy to serve you.

IDEAL FOR

**schools
hospitals
stores**

**public buildings
industrial plants
residences**

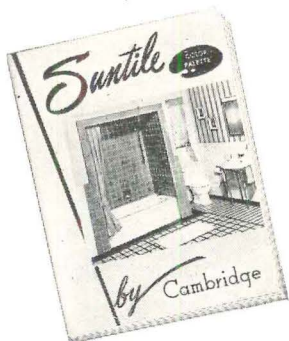

GET THIS EXCITING NEW COLOR PALETTE FOLDER!

Created under the direction of Faber Birren, leading color authority. 22 attractive wall colors, 27 beautiful shades of unglazed ceramic mosaic tile, 10 unique Suntile Camargo colors. All selected to give you a wide range of effective color treatments for walls and floors. Write today for your FREE copy, or see our Sweet's Catalog. Dept. AF-1, The Cambridge Tile Mfg. Co., Cincinnati 15, Ohio.

WAREHOUSES

The Cambridge Tile Mfg. Co.
470 Alabama St.
San Francisco 10, California

The Cambridge Tile Mfg. Co.
941 N. Citrus Ave.
Los Angeles 38, California



SUNTILE OFFERS YOU BOTH • BETTER TILE • BETTER INSTALLATION

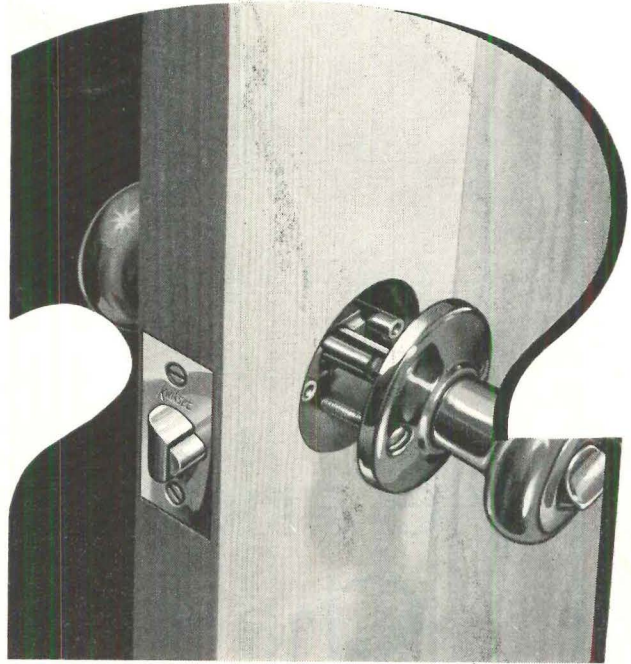
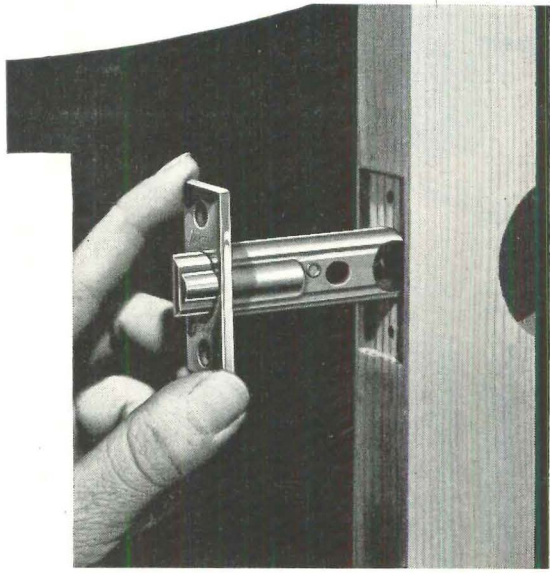

Kwikset
LOCKSETS

"400" LINE

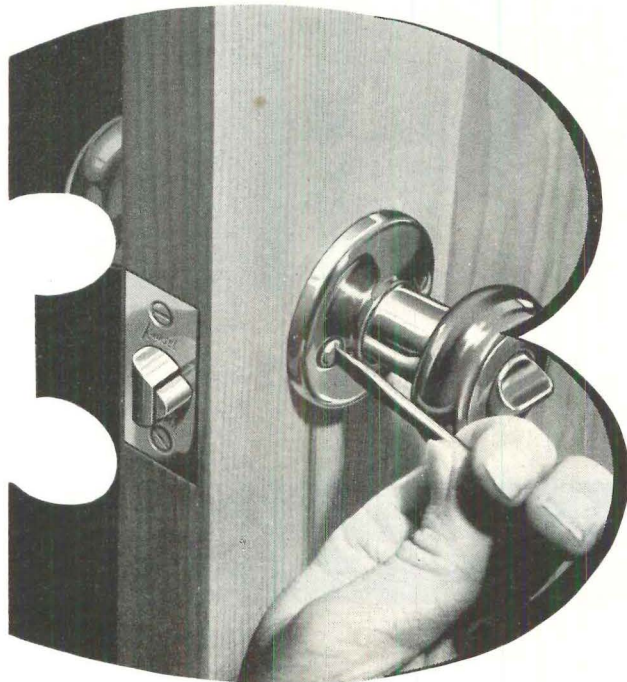

With America's number 1 economy lockset there are only 2 holes to bore . . . only 3 units to slip into place and it's installed—that fast! Here are other Kwikset "400" Line features: Rugged precision construction; durable high-quality materials; 5-pin-tumbler security; low unit cost; simplified, graceful beauty in lustrous, lifetime finishes . . . truly America's number-one economy lockset. Preferred by builders, contractors, jobbers, dealers, architects and homeowners . . . write for your copy of our colorful catalog featuring Kwikset's "400" Line and the new Kwikset "600" Line.

Kwikset Sales and Service Company

ANAHEIM, CALIFORNIA
Dept. A-1

IT'S INSTALLED!

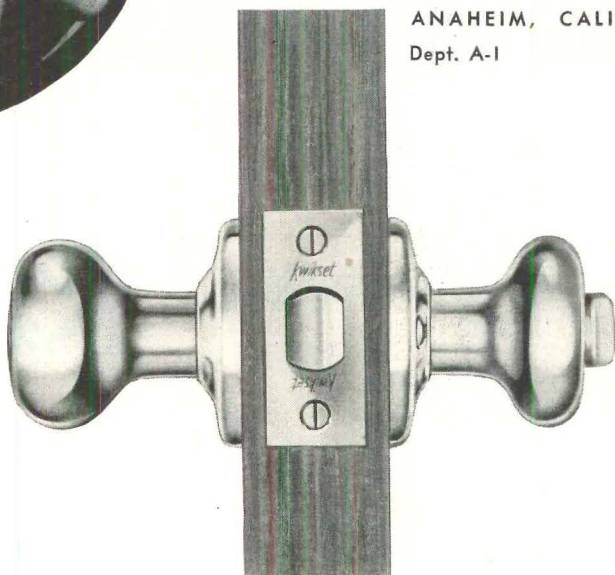

Style and Charm *far beyond its cost*

BRUCE RANCH PLANK FLOOR gives the beautiful distinctive effect of a random width plank floor—yet is much lower in cost and far simpler to install.



Red or white oak / Alternate 2¼" and 3¼" widths / Inlaid walnut pegs / New "Decorator" finish

- LAID LIKE REGULAR STRIP FLOORING
- NO SANDING OR FINISHING ON THE JOB
- FOR MODERN AND TRADITIONAL HOMES

BRUCE *Ranch Plank Floor*



*It's pegged and finished
at the factory*

SEE OUR CATALOG IN SWEET'S. FOR COMPLETE DATA, WRITE E. L. BRUCE CO., MEMPHIS 1, TENN.

Published by TIME Incorporated

EDITOR-IN-CHIEF.....Henry R. Luce
 PRESIDENT.....Roy E. Larsen
 EDITORIAL DIRECTOR.....John Shaw Billings

Architectural Forum
 THE MAGAZINE OF BUILDING

EDITOR AND PUBLISHER
 P. I. Prentice

EXECUTIVE EDITOR
 Joseph C. Hazen, Jr.

ARCHITECTURAL EDITOR
 Douglas Haskell

ART DIRECTOR
 Paul Grotz

ASSOCIATES: Eleanor Bittermann (Research), Peter Blake, Louise Cooper, Wilson Dizard, Sighe Kennedy, Walter McQuade, Harry J. Middleton, Carl Norcross, Boyce P. Price, Amnon Rubinstein, Richard Saunders (Washington), Madelaine Thatcher.

ASSISTANTS: Rosalind Klein Berlin, Linn Ericson, Marilyn Grayboff, Mary Jane Lightbown, Alice O'Connor, Nina Rabinowitz, Chloethiel Woodard Smith (South America).

MARKET RESEARCH DIRECTOR: Arthur S. Goldman.
 CONSULTANTS: Miles L. Colean, Ruth Goodhue.

GENERAL MANAGER: Robert W. Chastaney, Jr.
 CIRCULATION MANAGER: Walter F. Grueninger.

PRODUCTION MANAGER: Lawrence W. Mester.

ADVERTISING DIRECTOR
 George P. Shutt

Architectural Forum, THE MAGAZINE OF BUILDING is published monthly by TIME Inc., Time & Life Building, 9 Rockefeller Plaza, New York 20, N. Y. Address all subscription correspondence to 540 North Michigan Avenue, Chicago 11, Ill. Address all editorial correspondence to Time & Life Building, 9 Rockefeller Plaza, New York 20, N. Y. Yearly subscription payable in advance. To individuals or firms (and their employees) engaged in Building—design, construction, finance, realty; material distribution, production or manufacture; government agencies and supervisory employes; commercial and industrial organizations with a building program and their executives; teachers and students of Architecture and Engineering; professional clubs, societies and trade associations connected with the building industry; advertisers and publishers: USA, Possessions and Canada, \$5.50; Pan American Union and the Philippines, \$9.00; elsewhere \$12.00. To those not connected with the Building Industry: USA, Possessions and Canada, \$11.00; elsewhere, \$17.50. Single copies, if available, \$2. All copies mailed flat. Copyright under International Copyright Convention. All rights reserved under the Pan American Copyright Convention. Entered as Second Class Matter July 17, 1944 at the Post Office at New York, N. Y., under the act of March 3, 1879. Copyright 1951 by TIME Inc.

TIME Inc. also publishes TIME, LIFE and FORTUNE. Chairman, Maurice T. Moore; President, Roy E. Larsen; Executive Vice President and Treasurer, Charles L. Stillman; Executive Vice President for Publishing, Howard Black; Vice Presidents, Allen Grover, Andrew Heiskell, C. D. Jackson, J. A. Linen, P. I. Prentice; Vice President and Secretary, D. W. Brumbaugh; Comptroller and Assistant Secretary, A. W. Carlson; Circulation Director, F. DeW. Pratt; Producer, THE MARCH OF TIME, Richard de Rochemont.

VOLUME 94, NUMBER 1



NEWS	9
LETTERS	40
FRANK LLOYD WRIGHT	73
A four-color portfolio of the recent work of the dean of contemporary architects, with his own commentary on each building.	
RESEARCH LABORATORY AT RACINE, WIS.	75
BRICK AND CONCRETE HOUSE NEAR QUASQUETON, IA.	82
HOUSE OF CONCRETE BLOCK IN MILWAUKEE, WIS.	86
SOLAR HEMICYCLE NEAR MADISON, WIS.	90
HOUSE OF CYPRESS IN MADISON, WIS.	94
CIRCULAR HOUSE NEAR PLEASANTVILLE, N. Y.	98
CHAPEL AND LIBRARY AT FLORIDA SOUTHERN COLLEGE	104
EDITORIAL	109
A year's progress toward architect-builder teamwork.	
SUBSTITUTES FOR CRITICAL MATERIALS	110
With government diverting more and more metals from the building site, the industry will soon be scratching for substitutes. A preview of future materials problems and possible solutions.	
ARCHITECT SUGGESTIONS FOR HOUSEBUILDERS' PROBLEMS	112
A demonstration of how the architect can improve the livability and sales appeal of the builder's house—in the sensible use of glass, the economical integration of living, dining and kitchen space, the space saving provision of an interior bathroom, the appearance and function of fireplaces, the creation of space for outdoor living and the use of water as a decorative element—a portfolio of new design ideas.	
HOUSE BUILDER BILL ATKINSON	127
A profile of the man who is slated to head the National Association of Home Builders during the new year.	
CONTEMPORARY SUBDIVISION	130
Architect-builder collaboration combines construction economics and handsome design in 250 quick-selling houses for suburban New Jersey's \$16,600 price field. Builder Edward Klausner and Architects Nemeny & Geller experiment successfully with new design and construction techniques.	
HOUSE IN MEXICO	136
Architects Anshen & Allen design a strikingly different concrete and timber house which becomes part of the rugged mountain landscape.	
BELLUSCHI CHURCH	142
The Zion Lutheran Church in Portland, Ore. is a dramatic lesson in how beautifully and how economically today's new materials and methods can carry forward the tradition of Christian architecture.	
REVIEWS	174
PRODUCT NEWS	198
TECHNICAL LITERATURE	236

Cover: Photo by Ezra Stoller of the Johnson Wax Helio-lab, Racine, Wis.—see p. 75.

Create distinctive functional and decorative designs

with low-cost **KENTILE FLOORS**

**schools • stores • clubs
public buildings • offices • homes**



Direct traffic flow—relieve congestion and increase efficiency with floors like this. No matter how heavy the wear, Kentile will keep its light, bright colors... its quiet comfortable feeling underfoot.

THE ALMOST unlimited design flexibility possible with durable Kentile makes it more than America's leading asphalt tile floor! The variety of ways Kentile Floors can be used are limited only by the floor space available and the client's individual requirements.

Kentile's 25 new colors alone permit just about any design imaginable... add Feature Strip... die-cut ThemeTile and Kenserts... a special insignia custom-made by Kentile designers, and you can create a floor that will direct traffic... identify a lodge... departmentalize a store... instruct school age children.

The initial low cost of Kentile Floors... the economical installation and the minimum maintenance required, combine to make Kentile Floors ideal for decades of constant hard usage. To keep a Kentile Floor sparkling clean and new looking requires only mild soap and water plus an occasional no-rub waxing. Colors are permanent... can't wear off because they go clear through each tough tile and the smooth Kentile surface locks dirt and grime out.

Kentile goes down any place... even over concrete in direct contact with the earth!

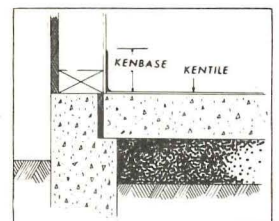

Kentile designers will create your insignia or emblem to your specifications and colors. Just as durable and easy-to-install as regular Kentile, this design will serve for a lifetime.

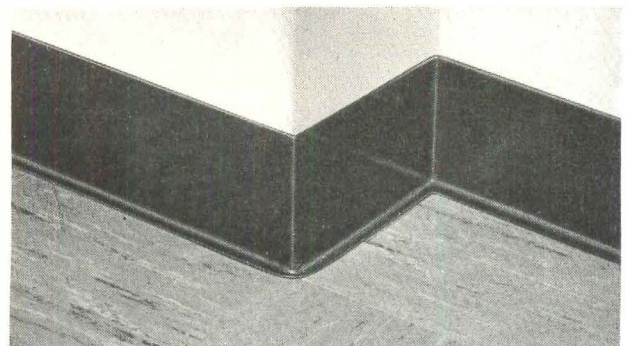

The perfect companion to a Kentile Floor is Kenbase! It can be applied against any smooth wall where it meets the floor area and effectively seals dirt-catching cracks and crevices. It never needs painting... scuff and mop marks won't show.

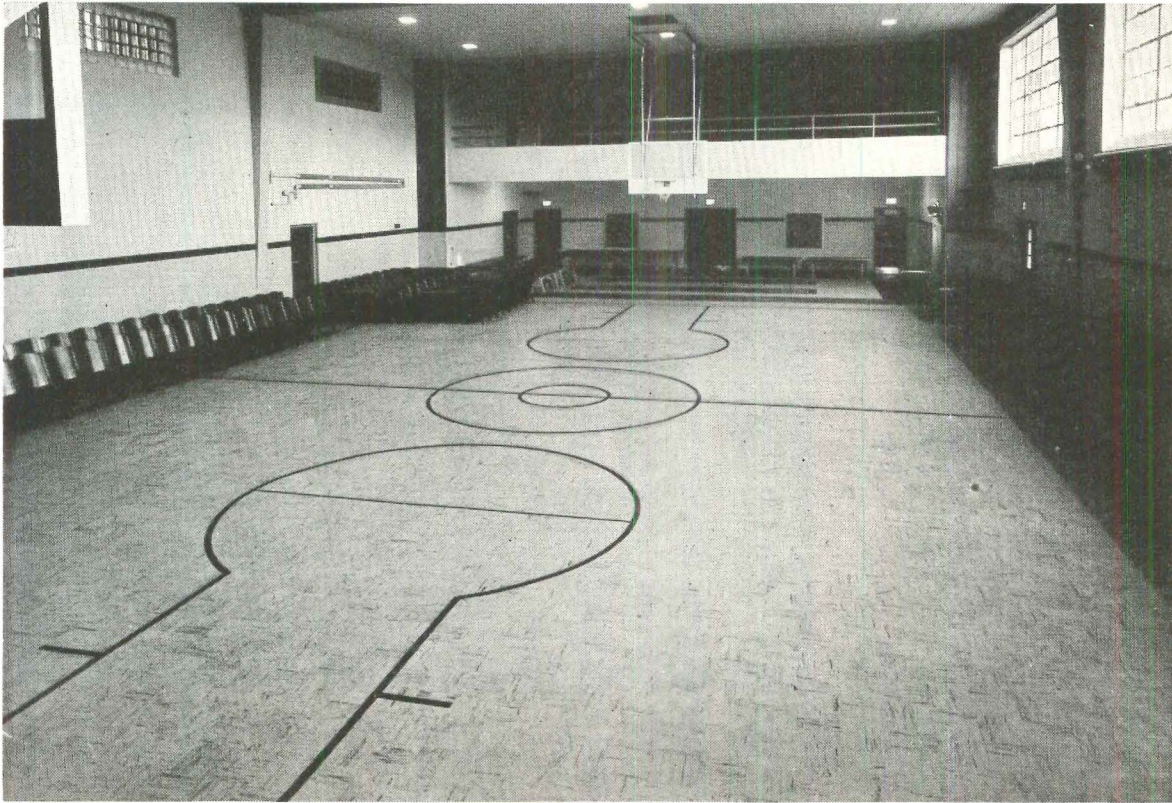

Schools, gymnasiums and public facilities can use this full-sized basketball court. It goes down as quickly and economically as regular Kentile...never needs repainting...colors and markings can't wear off.

Here is a Kentile Floor that could easily be adapted for a nursery or a children's playroom. The scuffing of young feet won't harm the floor and it is good for years and years of trouble-free service with the least amount of upkeep effort.

Identify departments or merchandise with a floor like this. What's more, the light, airy, colorful Kentile Floor meets customer approval...bringing business back and back again.



KENTILE®

The Asphalt Tile of
Enduring Beauty



KENTILE • KENCORK • KENTILE RUBBER TILE

KENTILE, INC., 58 Second Ave., Brooklyn 15, N. Y. • 350 Fifth Ave., New York 1, N. Y. • 705 Architects Bldg., 17th and Sansom Sts., Philadelphia 3, Pa. • 1211 NBC Bldg., Cleveland 14, Ohio • 225 Moore St., S.E., Atlanta 2, Ga. • Kansas City Merchandise Mart Inc., 2201-5 Grand Ave., Kansas City 8, Mo. • 1440 11th St., Denver 4, Colo. • 4532 South Kolin Ave., Chicago 32, Ill. • 1113 Vine St., Houston 1, Texas • 4501 Santa Fe Ave., Los Angeles 58, Calif. • 95 Market St., Oakland 4, Calif. • 452 Statler Bldg., Boston 16, Mass.

1

Unfailing Performance:

Whether installed on doors that bear the heaviest traffic, or on a "once-in-a-lifetime" escape exit, Von Duprin devices can always be depended upon to operate safely—and with minimum maintenance.

Many devices installed as long as 40 years ago are still on the job and still dependable in daily use. All Von Duprin devices are listed with Underwriters' Laboratories for accident hazard.

2

Lifetime Quality:

In exit hardware, Von Duprin A² and B² devices set the standard of quality with advantages like these . . . *Drop-forged* construction, proved stronger and longer-lasting than the finest castings . . . An X-Bar of extruded bronze built into the cross-bar to give extra stamina, extra rigidity . . . Weather-resistant architectural bronze exteriors . . . Bearing metal interior parts.

3

Harmonious Design:

Von Duprin devices are designed to fit into your plans and compliment them. With the Von Duprin line, you can choose from the most complete selection of top-quality rim and vertical rod types, to fit every type of exit. In every case, Von Duprin devices are designed with one thought in mind—to permit the most efficient operation in the handsomest possible package.

DEMAND ALL 3
IN EXIT HARDWARE!



Specify
Von Duprin

Fire and Panic Exit Devices

"THE SAFE WAY OUT!"

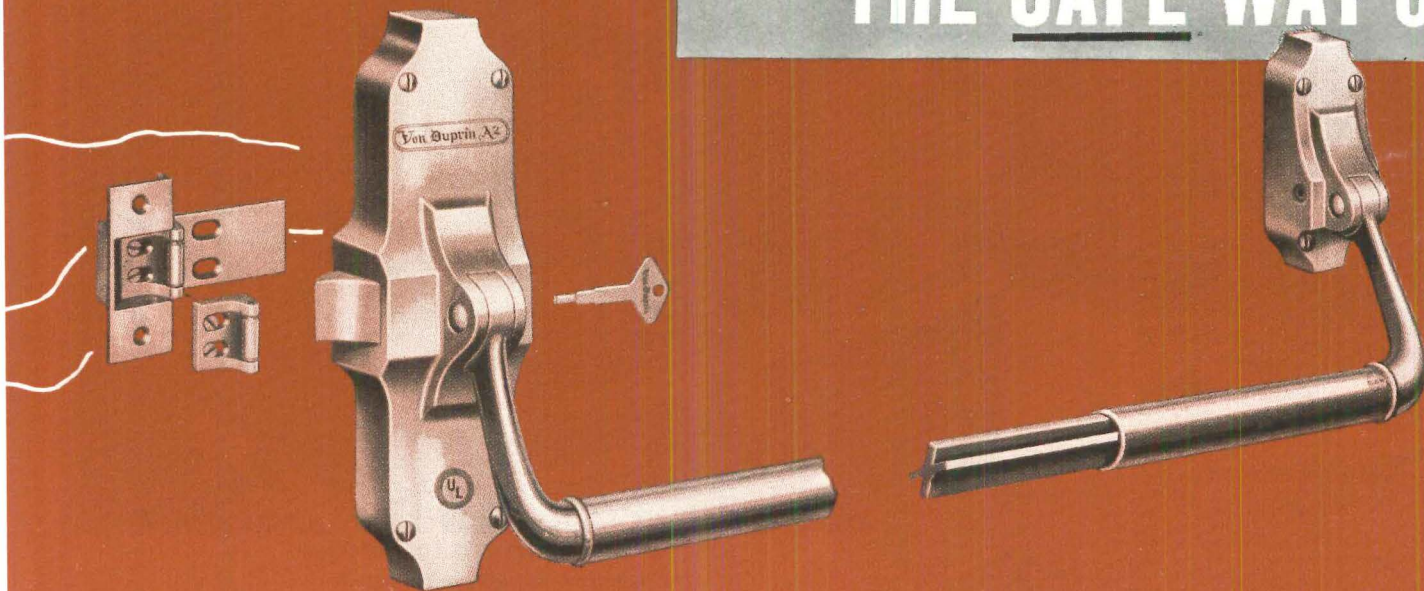

VON DUPRIN CONSULTATION SERVICE — For your convenience, Von Duprin representatives are located in 20 key cities. There's one near you. And it can pay you to know the Von Duprin "Exit Engineer" in your area. He has the engineering and hardware background to consult with you in exit planning. And he has the complete facts on Von Duprin exit devices and accessory hardware to save you time on specifications. Call on him—often. If you don't know his name, write:

VONNEGUT HARDWARE COMPANY, VON DUPRIN DIVISION, INDIANAPOLIS, IND.



Take it from
this **SUCCESSFUL**
builder!



He's M. M. Robinson, Prominent Detroit Builder—
Whose Three Current Apartment Projects Will
Feature a Grand Total of 486 Kelvinators!

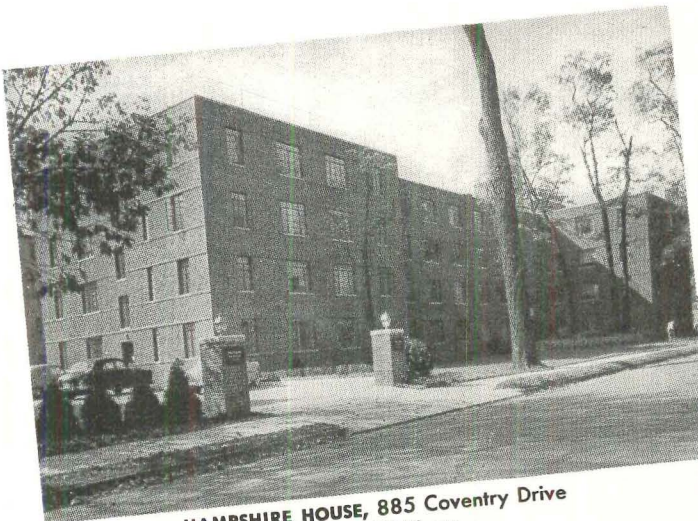

HAMPSHIRE HOUSE, 885 Coventry Drive
Detroit, Michigan
56 Kelvinator Refrigerators installed!



HUNTINGTON GARDENS, Oak Park, Michigan
374 Kelvinator Refrigerators installed!
Theo. N. Barthel, Designer; Jos. E. Wassell, Engineer

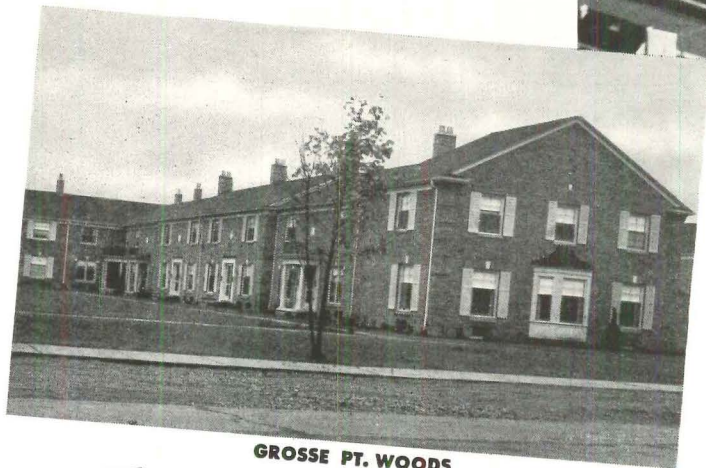

GROSSE PT. WOODS
Michigan
56 Kelvinator Refrigerators installed!

See Kelvinator
Booth No. 1
National Home
Builders Show!
Stevens Hotel, Chicago
January 21-25.

A BIG FACTOR in Detroit builder M. M. Robinson's outstanding success is his experience. He bases his choice of kitchen equipment on that long experience—and so chooses Kelvinator. He says he especially likes Kelvinator *dependability*, *lower cost* of ownership and universal *popularity* with tenants. Be sure to look into the cost-saving, trouble-free advantages of using Kelvinators in *your* next project. For full information, write to Dept. AF, Kelvinator, Division of Nash-Kelvinator Corporation, Detroit 32, Michigan.

Kelvinator

DIVISION NASH-KELVINATOR CORPORATION, DETROIT 32, MICHIGAN

ELECTRIC REFRIGERATORS • ELECTRIC RANGES • ELECTRIC FREEZERS • ELECTRIC WATER HEATERS • ELECTRIC AIR DRIER



Kelvinator featured exclusively, nation-wide,
in the Good American Home Program.

INDUSTRY'S NEW YEAR is ushered in with restrictive orders from a nervous government. Ahead looms the specter of more to come

The first quarter of 1951 will be a season of lengthening controls. The National Production Authority and the Economic Stabilization Agency will extend their hold broadly over the economy, changing the whole character of the market place and impinging unmistakably upon the life of everyone.

The change in tempo of the control operation since the November disaster in Korea has been tremendous. Until that time, aside from the occasional muscle-flexing of NSRB Chairman Stuart Symington and some bad footwork on the part of NPA Director William H. Harrison, the program was advanced with such caution that its administrators were accused of complacency. Actual expenditures were being made at a considerably slower rate than had been planned and then appropriations would permit. The armed services were placing orders and calling up men with no apparent sense of great urgency. Care was being taken not to withdraw materials from the civilian economy before their absorption for armament purposes was imminent. Price control was approached reservedly, with public statements on the subject implying that first application would be in respect to basic materials. The probable need for drastic economic controls was minimized, and prudence was shown in not instituting controls beyond the possibilities of enforcement.

Confusion to hysteria

The President's proclamation transformed the air of cautious confusion to something like outright hysteria. Appropriations for defense were much increased. NPA began to move quickly from its relatively amiable proportional restriction orders to prepare drastic curtailments of numerous end products made of copper, aluminum, zinc, cobalt, cadmium, and other critical materials, for probable effective dates late in the first quarter. In apparent discouragement at the Federal Reserve Board's befuddlement over the problems of restricting apartment and commercial construction by credit controls, NPA officials began to "examine" the probable volume of "nonessential" commercial building in 1951—and the specter of another L-41 Order loomed ahead. The prospect was that by April every metallic component of structures that had not been banned would be subject to some form of restriction, priority or allocation.

On the stabilization front, things were equally disturbed. ESA, newly equipped with Price Stabilizer M. V. Di Salle, former mayor of Toledo, was under pressure to do something. After an unproductive argument with the automobile makers, it slapped control on passenger car prices and threw the whole industry into dismay over internal cost, price and wage relationships. Having accomplished this, ESA proceeded to issue a notice stating that price increases after December 1 "will be regarded as subject to action by the Economic Stabilization Agency at the earliest feasible time." It then supplemented this warning with a set of "fair pricing standards" for the guidance of manufacturers and distributors.

With these steps, the economy was deep in the morass of direct controls.

Priorities to permits

Already the planned restrictions in the use of specific quality building products are at least as stringent as those of 1942-1945. The materials situation promises to be so serious that the effects of credit control may be considered distinctly secondary; indeed, it may be questioned whether further steps in this line are of sufficient importance to be bothered with. Materials shortages are certain to lead to a priorities system for building, which in turn is likely to result in some form of permit or programming system in which military construction, certain types of industrial building, and housing in defense areas will be favored.

Second quarter crucial

As things stand, these latter moves seem yet a few months off. Indications are that the second quarter will be the crucial time—with shortages beginning to hurt and priorities firmly established. The start on them will be gradual, probably by extensions of DO ratings and exemptions from materials conservation orders for military and industrial construction. It is not now contemplated that any direct attempt will be made to stop construction under way, even though the starting of some additional types of building may later be banned; and, in fact, aid may be given to the completion of work in progress. It is questionable whether restrictions will cover items affected by conservation orders if these were already on hand or in the process of manufacture or distribution when the orders are put into effect.

LIFE: Lisa Larsen



Charles E. Wilson

WILSON'S APPOINTMENT to mobilization job is one good omen for industry

The appointment of former General Electric President Charles E. Wilson to head the newly-created Office of Defense Mobilization is symptomatic of the change in the pace of American rearmament. Wilson's previous experience as Vice Chairman of World War II's War Production Board, and his powers under the Presidential Emergency Declaration, give him both the knowledge and the authority to proceed vigorously. While he had made no firm statement of his intentions two weeks ago, there were good clues as to their eventual content.

For one thing, Wilson has a high regard for American production possibilities during increased defense spending. He showed this at the BUILDING Round Table discussion on construction-during-rearmament on Sept. 20. At that time he frequently used the word "superimpose," and indicated four reasons for believing we could have both guns and butter:

1. "Much greater" plant facilities than in 1940.
2. Existing separate plants for planes and tanks.
3. The possibility of a 48-hour week if necessary.
4. "Great improvements" in efficiency and skills.

His present thinking has probably been modified by the greater defense appropriations now planned. (The estimate was then \$40 billion annually, but Chinese intervention has now sent government estimates up to \$65 billion annually.) In the face of the Korean reverses and the increased appropriations, there is considerable public pressure on Wilson, as on all government officials, to cut down everything not needed for the war effort and to produce weapons above all else. The holders of this view are the ones who suggested in 1940 that the economy be cut back from \$80 billion to \$53 billion while everyone pulled in his belt. Instead, the American economy expanded to where military production alone

(Continued on page 13)

HARD USE

makes your decision easy

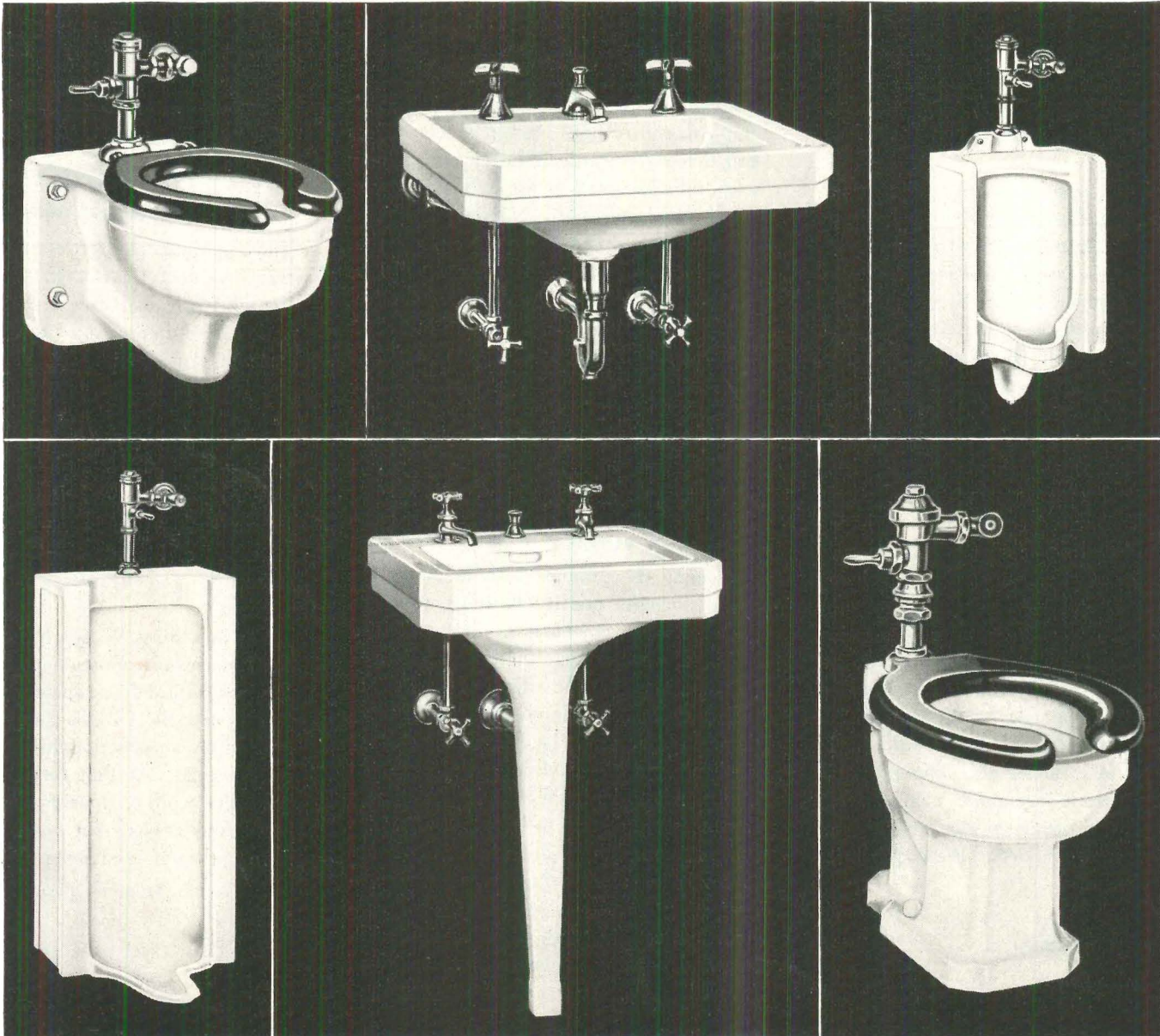

CASE WALJET #2100. Wall Hung Siphon Jet Closet with hard rubber open front seat, concealed check hinge.

CASE CASCO #2300-A. Vitreous China Straight Front Urinal Stall.

CASE WYNGATE #600. Vitreous China Lavatory. Square basin. Anti-splash rim, heavy wall hanger.

CASE WINDSOR #720. Lavatory with leg, square basin, anti-splash rim. Made in 2 sizes.

CASE CASCO #2325-A. Vitreous China Wall Hung Washout Urinal with shields, integral flush spreader and spud.

CASE #1600. Syphon Jet Flush Valve Closet Combination with elongated bowl.

The heavier the washroom traffic for which you must plan, the more vital it is to make sure the plumbing fixtures will give long years of service with a minimum of maintenance. Case fixtures are molded of the finest vitreous china, highly lustrous and unsurpassed in permanence, sanitation, and resistance to acids and discoloration. Fittings are specially designed for the needs of the fixture in which they are used—a factor of great importance in long service life. The fixtures are available with chair carriers—a necessary safeguard in many installations. For the name of your Case Distributor, see your local Classified Telephone Directory— or write W. A. Case & Son Mfg. Co., 33 Main Street, Buffalo 3, New York. Founded 1853.

For industrial, institutional and commercial installations

Case *Fine Vitreous China*



MENGEL

Flush DOORS

give you the advantages of this fine cabinet-maker's construction!

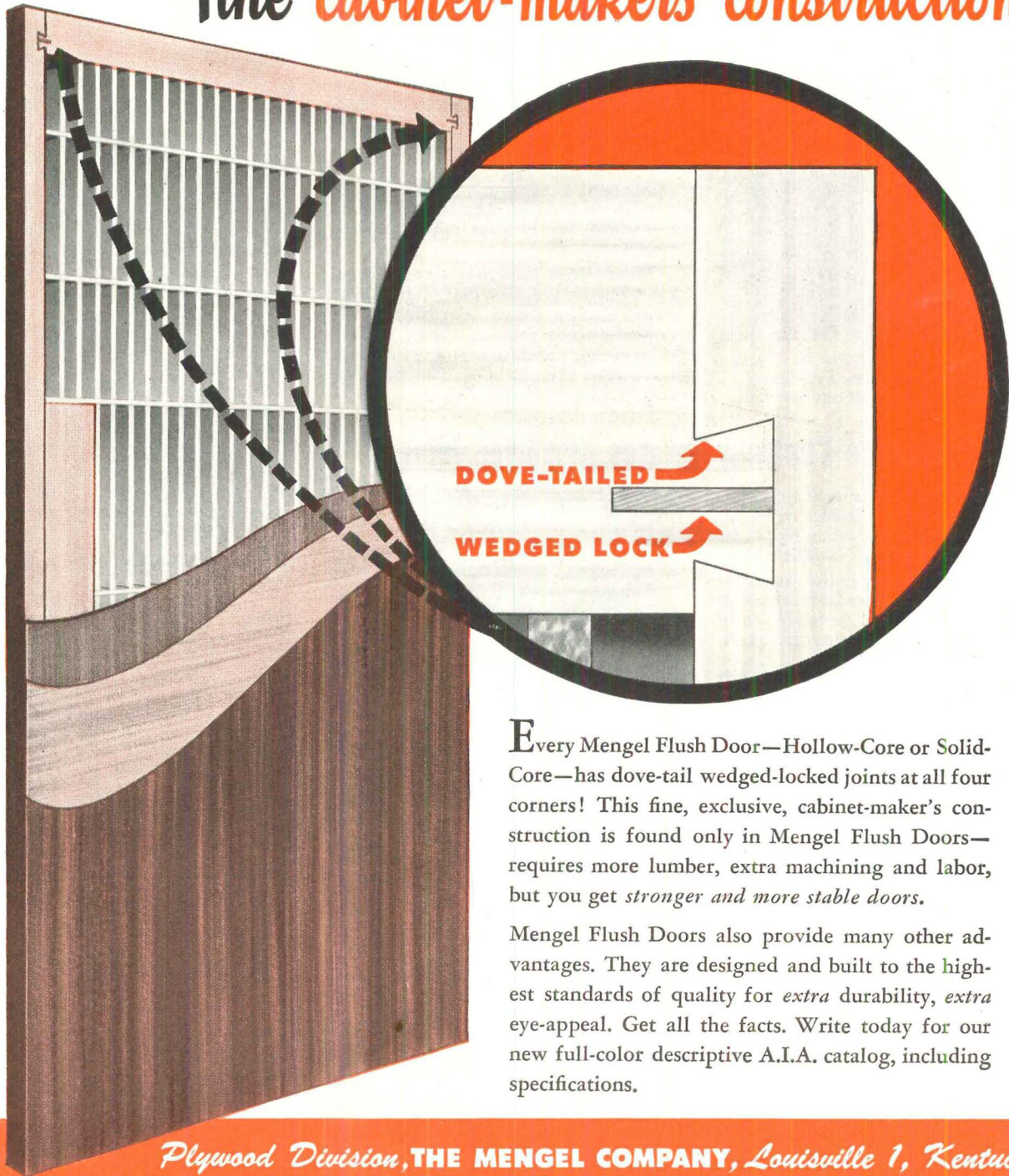

Every Mengel Flush Door—Hollow-Core or Solid-Core—has dove-tail wedged-locked joints at all four corners! This fine, exclusive, cabinet-maker's construction is found only in Mengel Flush Doors—requires more lumber, extra machining and labor, but you get *stronger and more stable doors*.

Mengel Flush Doors also provide many other advantages. They are designed and built to the highest standards of quality for *extra durability, extra eye-appeal*. Get all the facts. Write today for our new full-color descriptive A.I.A. catalog, including specifications.

Plywood Division, THE MENGEL COMPANY, Louisville 1, Kentucky

WORTHINGTON

WORTHINGTON PUMP AND MACHINERY CORPORATION
HARRISON, NEW JERSEY

AIR CONDITIONING REPORT

Specialists in air conditioning
and refrigeration
for more than 50 years

Cool Sears Gets Warm Reception In Rio

It was practically a fiesta day when Sears, Roebuck and Co. opened its new retail store in Rio de Janeiro.

At dawn before the opening the lines had formed, and before the day was through, 123,000 Brazilians had stormed the premises. First day's receipts were in excess of \$500,000.

Among the attractions in this new Sears store is Worthington air conditioning, a welcome feature in Rio's

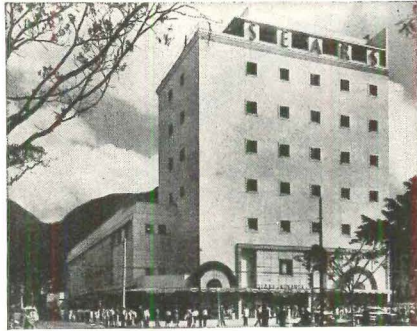

Sears, Roebuck store at Rio de Janeiro, Brazil, is air conditioned by means of Worthington centrifugal refrigeration.

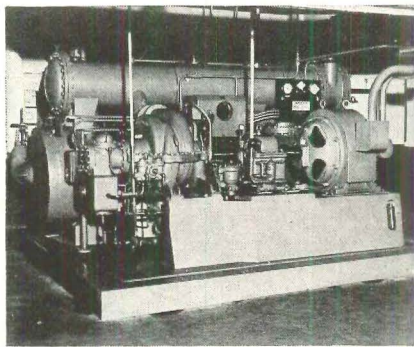

Worthington centrifugal compressor in Sears, Roebuck's Trenton, New Jersey, store.

semi-tropical summers. Chilled water for the air conditioning is supplied by a 55C66 centrifugal refrigeration system.

Meanwhile, another Sears store, closer by in Trenton, New Jersey, was being equipped with Worthington air conditioning, joining other Worthington-equipped Sears stores in Allentown, Pa., Atlanta, Ga., Kansas City, Mo., and Knoxville, Tenn.

How Insurance Company Insures Employee Morale

One of the biggest insurance companies in the country believes in insuring the happiness and efficiency of its personnel through air conditioning.

The new addition to the beautiful Omaha, Nebraska, home of the United Benefit Life Insurance Company, and its affiliates, is air conditioned through-



Home office of the United Benefit Life Insurance Co., Omaha, Nebraska.

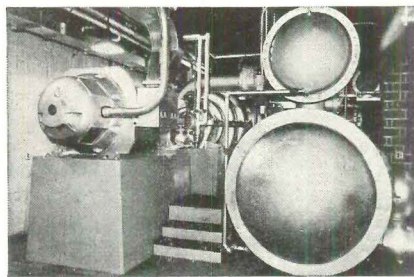

Worthington 75C99 centrifugal compressor at United Benefit Life Insurance Co.

out by a Worthington 75C99 centrifugal compressor with 727 ton capacity. This unit chills water, which is sent to air washers to control the temperature and humidity of the air, which is then distributed throughout the building. Engineer: Charles S. Leopold, Philadelphia.

Oilmen Strike It Lucky

In the heart of the "oil country," at Garland, Texas, an up-to-the-minute new plant has been opened by Emsco Derrick and Equipment Company to provide oilmen with the latest in such essential equipment as sucker rods, deep well plunger pumps, etc.

For greater comfort of visitors and employees, as well as peak performance, the finest air conditions are main-

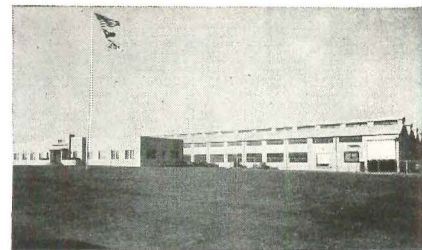

Modern new plant of Emsco Derrick and Equipment Company at Garland, Texas.

tained in the offices, laboratories and engineering rooms by Worthington equipment.

The large area of the main office is serviced by a 3HF6 Freon-12 compressor unit with an ECZ-301 evaporative condenser, and an AHY-301 Air Conditioning unit. Two SCY package air conditioners, designed for compact areas, cool the small offices in the shop section.

Architect: Fooshee and Cheek, Dallas

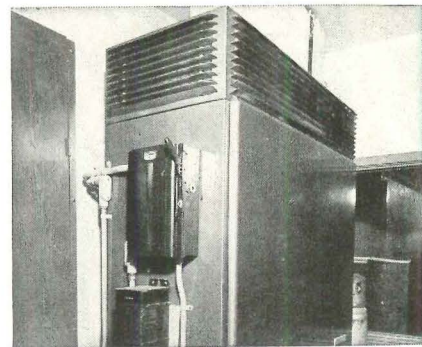

Worthington package air conditioner at Emsco.

WORTHINGTON



AIR CONDITIONING AND REFRIGERATION

A complete line . . . in which all the vital components are made, not just assembled by Worthington. For more worth with Worthington, see your nearby Worthington distributor (consult Classified Telephone Directory).

reached \$100 billion—with \$120 billion worth of civilian goods on top of it. It is far more likely that today, with the economy running along at a \$300 billion clip, and with Wilson's previously noted regard for U.S. production capacity in mind, the gross national product will expand to allow an increase in both civilian and military production.

But any thought that this means a hay-ride for builders, or anyone else, is dead wrong. Shortages, even in the months just ahead, will be as severe as any in World War II (see p. 9) and tax rates will be higher during a pay-as-you-go military expansion. While the most commonly used estimate for housing starts in 1951 is 800,000 (it came from the Federal Reserve Board originally), there is speculation in Washington that the shortage of copper is so extreme that this, combined with efforts to save and stockpile other metals, will cut starts back to 500,000 or less. One reason for this is that the U.S., which is not now in a position to produce as much copper as it did in World War II, needs greater amounts of it (along with steel, aluminum, etc.) just to keep the economy afloat at its expanded level.

Wilson's problem is to combine his faith in the American industrial potential with the hard fact of shortages. (One view about shortages is that we simply haven't enough scarce metals to win a big war, if one should start now.) His probable solution to this dilemma will be to let normal civilian expansion take place in those areas of the economy where it does not infringe on the metals shortage. Where does this leave housing? Except for military and defense housing (see page 17), pretty far out in the cold. Also well into a cooler climate is commercial building. Only industrial building, military installations and related defense items—including civil defense—stand to hold their own or gain.

However, despite the impending pain, the cause seemed a good one. Said one New Orleans building materials supplier, in answer to a BUILDING query: "The military must have the national production if we are to survive as a free nation."

Which was probably just what Charles E. Wilson was thinking.

WASHINGTON DECENTRALIZATION spreads from local "608" apartments to mid-west cities

Frantically combing Washington to find roosting places for its growing family of defense agencies, the government has had to adopt heroic measures. For one thing, it has hit upon the device of leasing a couple

of "608" efficiency apartments in the final stage of completion. It has also decided to move to other cities all bureaus and activities not needed close at hand. Even so, it still faces a tighter space situation than existed in World War II.

As a kind of major-domo in charge of the government's household operations, the General Services Administration has taken on the headache of looking for lodgings in Washington or wherever else the roaming bureaus may alight. In addition to this, it builds and parcels out space in federal buildings.

Before leasing the 608 projects, it exhausted all other possibilities in Washington. The *Washington Post's* old building, vacated when the paper moved into sumptuous new quarters, was taken over lock, stock and barrel. A sizable chunk in the new Cafritz "park-at-your-desk" building has been taken over to give Administrator Foley's cramped HHFA more elbow room. Even old residences are being gobbled up whenever one can be found near a bulging bureau. NSRB is already using several such makeshifts for housing its overflow.

Approval by the FHA was a necessary first step before the General Services Administration could start talking business with the owners of the two 608 apartments—the State House and Boston House projects. This is because FHA has always felt that its mortgage insurance program should be devoted exclusively to providing living quarters. However, since a matter of national interest was involved, it did not demur in these cases.

Government as a tenant

While the details of the leases for the State House and Boston House projects have not been finally settled, it is understood that the government will pay a rental at least as high as the buildings would collect when fully occupied, plus a reasonable margin to cover reconversion costs when the properties are returned. If a voluntary deal cannot be worked out, the government can always resort to its broad condemnation powers under the Defense Production Act and take any building it needs, letting the courts adjudicate the rent or sale price.

When it comes to decentralization, the government really means it this time. Practically all of the former "evacuee" departments have been allowed to wander back. Those leaving under the new program will be told to stay put in their new locations. Already there's talk of sending 35,000 workers into the provinces and the number may well be increased. When a large group of government employees is shifted to a new city, a family house as well as an office

space problem is usually created. This is particularly true of the moderate-sized cities which are under consideration as new homes for the migrant bureaus. Frequently mentioned as less-likely target areas are Omaha, Columbus, Kansas City, Des Moines, Albuquerque, Fort Wayne, Columbia, S. C., and Charlotte, N. C.

Not to be confused with the cross-country decentralization plan is the scheme for dispersing vital governmental activities around the outskirts of Washington. The Administration is still trying to get this proposal through Congress by insisting that there is no other way to prevent the disruption of essential operations in the event of attack. Congress has to give its okay because an appropriation of \$190 million is being sought to construct a series of reinforced concrete buildings for the agencies scattered around the rim. If dispersal continues to be sidetracked on Capitol Hill, officials warn that decentralization may have to take on a bigger load to make room for the expanding agencies.

EXCESS PROFITS TAX penalizes builders for 1950 boom

The excess profits tax bill on corporate earnings, one of the few Presidential requests to squeeze through the final session of the old Congress, promises to hit builders like a load of bricks. Under the bill excess profits are computed on the base period 1946-1949. The tax, retroactive to July 1, is 77 per cent on everything over 85 per cent of the average annual earning during this period. Whether or not there can be an argument as to the essential theory of the bill, housebuilders make the plausible complaint that there is no justification in applying it to them since their industry is actually a casualty of the mobilization program.

Most builders stepped up their 1950 operations in keeping with the policy of the President's Economic Council and HHFA, favoring the utmost expansion of residential construction to lick the housing shortage. Then came the Korean war and they were told to cut back. But by making the tax retroactive to July, builders will get the full impact—even though the program they were working on had nothing whatever to do with the defense effort. They will have to shell out an extra amount on the profits they made in sales during the second half of 1950—and all subsequent profits, too.

Since practically all builders are incorporated they come squarely within the provisions of the bill.

(Continued on page 17)

Today's Modern Homes
Start with
MODERN KITCHENS...



RANGES • REFRIGERATORS • DISHWASHERS • DISPOSALLS® • WATER HEATERS • AUTOMATIC WASHERS



...and **Hotpoint** Leads in Modern All-Electric Kitchens and Home Laundries

Regardless of the type or price of homes you build, you are justifiably right in claiming your kitchens to be the most modern offered anywhere . . . **if they are Hotpoint All-Electric Kitchens.**

Kitchens in modest bungalows or small apartments can be just as modern as kitchens in pretentious mansions—and just as efficient . . . **if they are Hotpoint All-Electric Kitchens.**

Even if your *immediate* plans are for remodeling or modernization, your kitchens can be as compact or expansive as your needs dictate,

as conveniently designed and as efficiently modern as tomorrow . . . **if they are Hotpoint All-Electric Kitchens.**

Engineered to be the finest . . . designed for the greatest utility and styled at the peak of modern custom, the Hotpoint *All-Electric* Kitchen has made *Better Living* available to all homemakers. You can build *Better Living* into your homes if you will remember—Today's Modern Homes Start with Modern Kitchens . . . and Hotpoint Leads in Modern All-Electric Kitchens and Home Laundries. Let Hotpoint help you set the standard for *Better Living* in the homes you build.

Write now for free literature on Hotpoint Home Appliances . . . Hotpoint will gladly give you helpful counsel in kitchen and home laundry planning for your particular project.

Hotpoint Inc.

CLOTHES DRYERS • ROTARY IRONERS • FOOD FREEZERS • CABINETS

(A General Electric Affiliate)

5600 WEST TAYLOR STREET, CHICAGO 44, ILLINOIS

**You'll want
these facts
for your
files!**

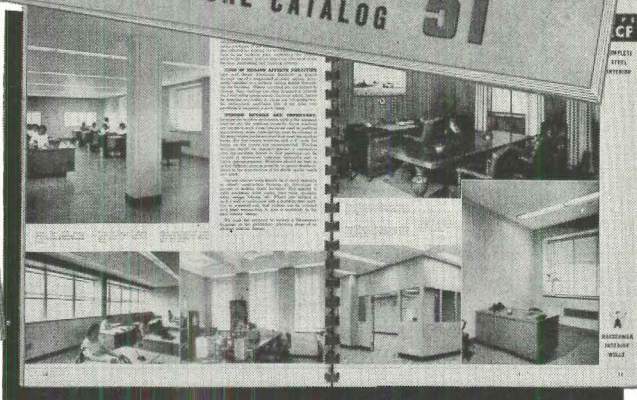
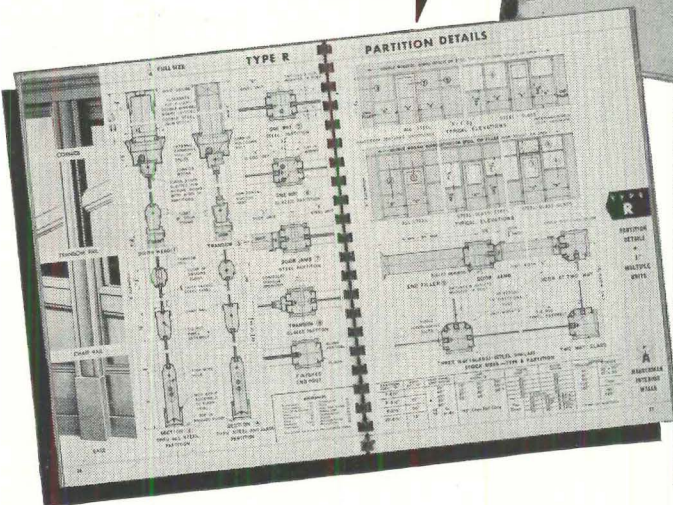
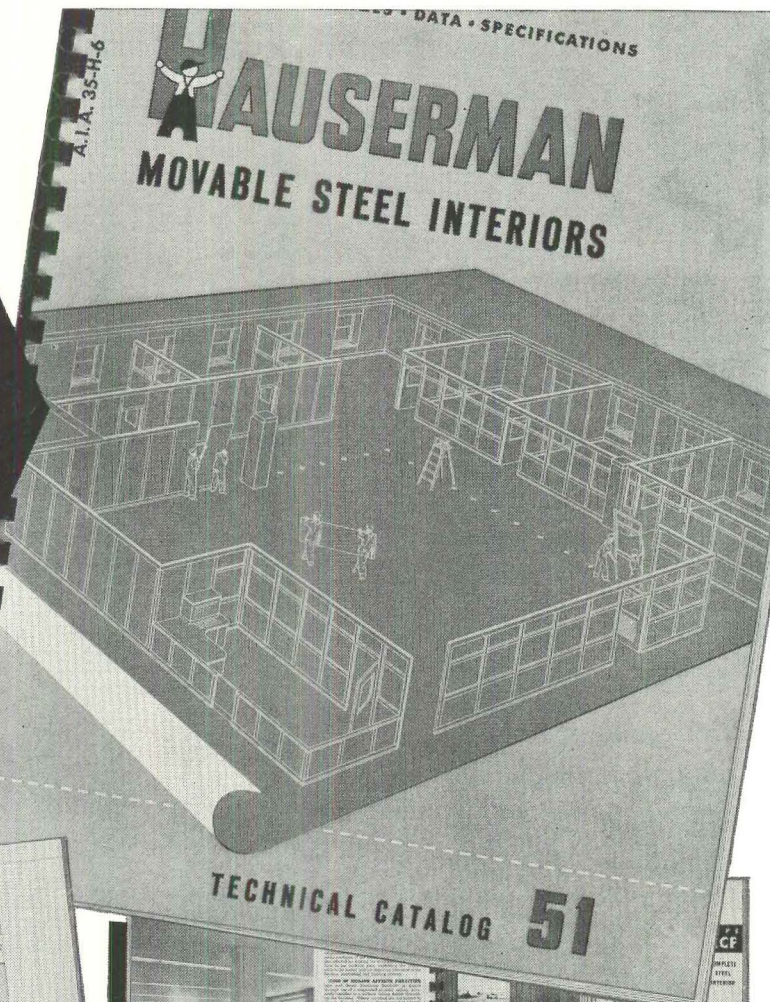

Send for your 1951 Hauserman Catalog now!

This new 1951 Hauserman Catalog is packed with technical information on Hauserman *Movable Steel Interiors* for every type of commercial, industrial and institutional building.

Contents include all wall types and their various uses; installation and technical data; sectional drawings; installation photographs and a wealth of other essential information.

This new 1951 Catalog, plus the help of

Hauserman personal engineering service in *your* office, makes it easy for you to specify Hauserman *Movable Steel Interiors* . . . the most modern interiors available.

Send for Hauserman Catalog 51 today. The E. F. Hauserman Company, Home Office, 7101 Grant Avenue, Cleveland, Ohio. Branch Offices in Principal Cities. See "Partitions" in your classified telephone directory.



ORGANIZED FOR SERVICE NATIONALLY SINCE 1913

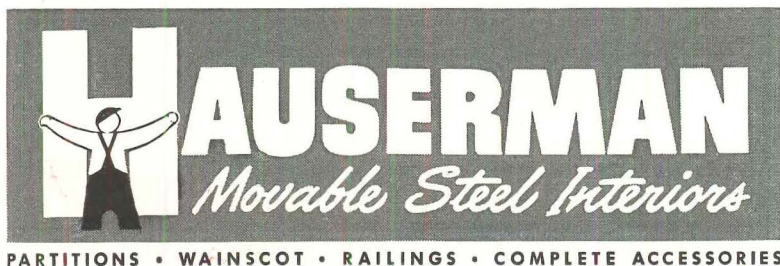

THE E. F. HAUSERMAN CO.
7101 Grant Ave., Cleveland 5, Ohio

Please send me your new Hauserman Technical Catalog 51.

Name

Title

Company

Street

City State

CANTONMENT CONSTRUCTION will be bigger job than expected

In struggling to keep pace with the mounting mobilization tempo, defense officials have heretofore been spared one early World War II worry. There were enough training camps left over to take care of almost any conceivable increase in military personnel—or so they thought. But, when the President ordered a 1 million increase in the armed forces as part of his national emergency proclamation last month, they looked again, added up their totals—and lost much of their confidence.

True enough they would not have to start from scratch this time; acquire land, install utilities, link up with highway and rail systems. But in many of the surplus camps the temporary barracks have either deteriorated so badly that they require major rehabilitation or they have been dismantled for salvage. What are termed "inactivated" posts have been kept in somewhat better shape. In these places the armed services have tried to stretch available funds sufficiently to follow a 20 per cent maintenance policy. At best, this has meant little more than tacking on roofs that were about to fall off.

While the relatively few active stations have been kept in fairly good condition, there are not enough of them to accommodate earlier increases in the training program. Already 14 camps have been reactivated. To handle man power quotas for a still larger fighting force, the Defense Department has mapped out a series of moves. First it will rehabilitate barracks at camps now in service. Then it will reactivate some of the closed-down stations—a process that requires from 30 to 60 days, depending on the state of disrepair. To meet additional space requirements it will build new structures at existing camps. Only as a last resort will it de-mothball surplus camps.

No one knows the volume of new construction that will be required. But Pentagon planners frankly admit that it will be more than they had estimated before the President raised the ante. As it now stands, the stepped-up military program calls for 3.5 million men in the armed services by Spring. If there are any further hikes in military man power, all bets will be off. In such an event the Department of Defense would reluctantly have to restore enough surplus camps to handle the training, a job that would require large scale rebuilding operations.

Barring all-out mobilization, defense officials believe they can handle the cantonment problem without straining the

supply of lumber, wallboard and gypsum products. Lumber industry spokesmen are in general agreement with this. They don't believe that military needs, even under stepped-up mobilization, will put much of a dent in the indicated 1951 production of 40 billion board feet. All told, about 1.3 billion board feet will be needed by the military.

Since the work will be decentralized through the field offices of the Corps of Engineers and Naval districts, Washington officials believe that local builders will stand a good chance of getting some of the contracts—particularly those for rehabilitating existing structures.

DEFENSE HOUSING PLANS include a revival of FHA's Title VI

The housebuilding industry last month began to realize that a substantial portion of it would soon be back in the defense housing field, where Administrator Foley's Housing & Home Finance Agency was carrying out a new mandate to meet the housing requirements of bulging defense communities. Already a rough draft of the necessary legislation was being whipped into shape in closed conferences between HHFA and the Budget Bureau. Apprehensively watching the awesome process, building men fervently hoped that a few lessons would be learned from the government's experience in trying to call its housing shots during World War II. As one of them sadly remarked: "They seem bent on making the same mistakes, only this time they apparently intend to make them faster."

No great mystery existed as to the general nature of the program that would be tossed into the lap of the new Congress. There would be a new mechanism to gear FHA's mortgage insurance operations to the more hazardous task of underwriting private building ventures in expanding defense areas. A \$1 billion ceiling was being mentioned—enough insurance authority to produce about 100,000 housing units. It would be a somewhat subdued form of the agency's wartime Title VI. So as not to stir up painful memories among Congressional and other critics who feel that the former operation gave builders too much gravy, it would be known as Title IX.

In addition, there would be a new program of government housing designed for areas where private builders and lenders would not venture even under the stimulation of liberalized mortgage insurance. The plan was to let the Public Housing Agency or a new HHFA unit take care of this phase of the operation, farming out

the building and managing of the projects to local housing authorities. Finally, federal assistance would be provided to help swollen communities finance needed public works like schools and water and sewage system extensions. Tentatively, the budget for direct government housing and community facility loans was set at \$300 million, although it was realized that this would just be a start. The ratio of housing to community facility allotment was expected to be about two to one.

While Title VI was predicated on current costs, Foley's braintrusts were determined to be more cautious this time and insist that builders be held to long-term values. If it would ease official minds any, building men were inclined to shrug their shoulders over such hair-splitting about the valuation approach. But they made one thing clear. Unless the end result was a realistic attitude toward present prices, there wouldn't be much use bothering about the program.

\$9,000 Value limit

Otherwise Title IX will be a more or less dressed-up version of Title VI. High percentage loans direct to builders will be insured both in the case of individual houses and multi-family developments. The loan ratio will probably be 90 per cent. The construction will have to be in a specified price class and in areas designated by the agencies in charge of putting the country on a war footing. The valuation limit proposed for individual houses is \$9,000 with successive step-ups of \$1,000 being tacked on for a third and fourth bedroom. On the plausible theory that most defense workers will not be interested in acquiring a permanent home, builders will be required to hold their houses for the rental market for a reasonable period. If no defense workers try to rent the properties within the stipulated time, the builders will then be free to dispose of them any way they can. The valuation limit on apartment structures will be \$8,100 per family unit.

Most important of all, the provision in the FHA basic law requiring that each insured loan be "economically sound" will be waived—as it was under Title VI. This will permit the agency to wade into areas where there may be some doubt as to the sustained nature of the housing demand. Finally, a separate insurance fund will be set up to absorb the extra risk, thus protecting the Title II reserves from a possible drain.

Obviously it goes without saying that FHA's counterpart of the curbs imposed by Regulation W will be set aside in the case

(Continued on page 21)



13 million reasons for choosing FRIGIDAIRE

The fact that over 13 million Frigidaire refrigerating units have been built and sold is definite proof of their overwhelming popularity. And the reason for that popularity is the outstanding quality of the product. The quality that has proved over and over that Frigidaire makes a good building better. The genuine Frigidaire quality that is the end result of over 30 years of engineering and manufacturing experience in the field of refrigeration.

To millions of homemakers, the very name "Frigidaire" is synonymous with quality. And, whether they are potential homeowners or apartment dwellers, Frigidaire's popular appeal can

exert a powerful influence on them in helping to establish the desirability of your buildings.

Frigidaire Model AM-60 (illustrated) has been designed to meet the particular demands of today's modern apartment and small-home kitchens. Has 6 cu. ft. capacity—11.7 sq. ft. of shelf space—16-lb. capacity Super-Freezer—yet requires a minimum of floor space.

FRIGIDAIRE

America's No. 1 Line of Refrigeration and Air Conditioning Products

Be sure to visit Frigidaire Exhibit, National Association of Home Builders, Jan. 21-25—Hotel Stevens, Chicago, Spaces 74, 75, 76.



Money-saving Meter-Miser . . . simplest cold-maker ever built. Oiled for life, sealed in steel, it is amazingly economical, compact, trouble-free.

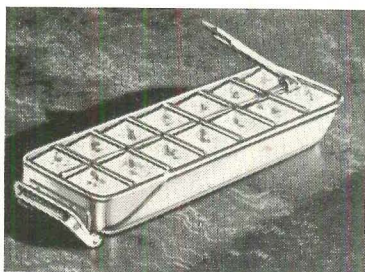

Double-Easy Quickcube Ice Trays . . . slide out instantly and release cubes quickly with finger-touch ease—two or a trayful. All-aluminum construction.

FREE . . . complete quick facts about the Frigidaire products shown below are yours for the asking. Look for your Frigidaire Dealer's name in Yellow Pages of phone book. Or mail the attached coupon today.

Frigidaire Refrigerators

3 types—4 series— sizes from 4.3 to 17.1 cu. ft. capacities.



Frigidaire Electric Ranges

9 models from apartment house size to twin-oven models.



Frigidaire Air Conditioners

Window-type Air Conditioners in 2 models. Self-contained models come in 3- and 5-ton sizes.



Frigidaire Water Heaters

30- to 80-gallon capacity. Round and table-top models.



Frigidaire Automatic Washer

The only Automatic Washer with live-water action! Gets clothes clean at the touch of a dial.



Frigidaire Electric Clothes Dryers

Automatic. Will dry clothes in any kind of weather. Variable temperature control. Built-in ozone lamp.



Frigidaire Electric Ironers

Cut ironing time in half. Prestoe-Matic foot control leaves both hands free to guide clothes.

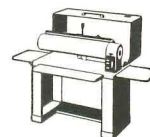

Frigidaire Electric Dehumidifier

Removes moisture from air automatically. Dozens of uses. Powered by Meter-Miser mechanism.



Mail coupon for full information

Frigidaire Division, General Motors Corp., 1498 Amelia St., Dayton 1, Ohio. (In Canada, 708 Commercial Road, Leaside 12, Ont.)

Please send further information about Frigidaire products checked below:

- | | |
|---|---|
| <input type="checkbox"/> Refrigerators | <input type="checkbox"/> Food Freezers |
| <input type="checkbox"/> Electric Ranges | <input type="checkbox"/> Kitchen Cabinets & Sinks |
| <input type="checkbox"/> Electric Water Heaters | <input type="checkbox"/> Room Air Conditioners |
| <input type="checkbox"/> Automatic Washer, Ironer & Dryer | <input type="checkbox"/> Electric Dehumidifier |

Name.....

Firm Name.....

Street & No.....

City..... County..... State.....

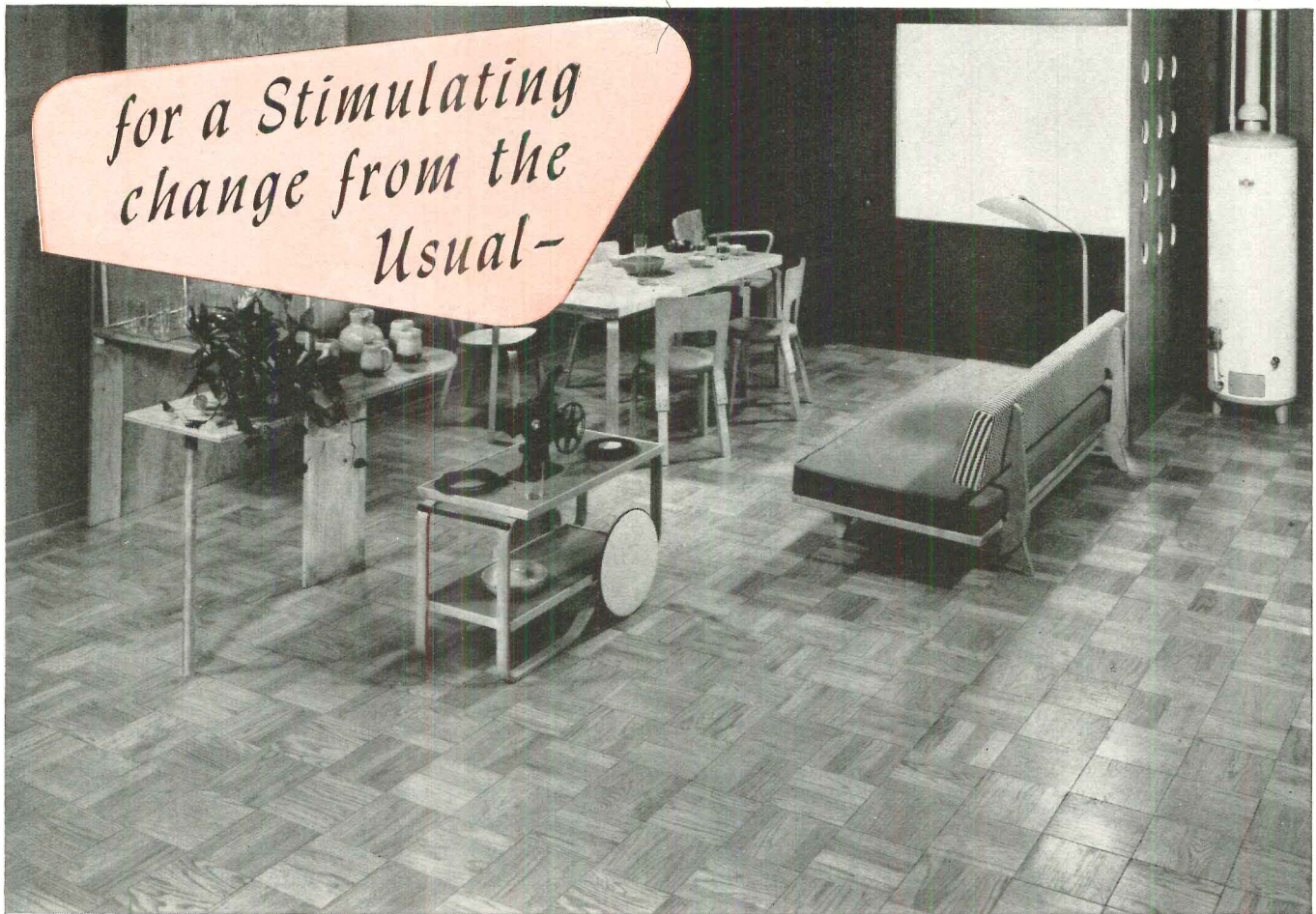

BRADLEY UNIT WOOD BLOCK FLOORS!

This striking departure from conventional strip spotlights block floors as smartly appropriate to the style and purpose of their setting.

In providing stimulating variation, Bradley Unit Wood Blocks are versatile, being nailed to wood sub-floors or laid in mastic over concrete. They're an exciting, modern embellishment in hardwood flooring design perfectly suited to homes, apartments, schools, public and business buildings.

Blocks are square and come in a range of standard sizes*, 9" by 9" shown above being the most widely used. Tongued and grooved like strip flooring, they provide an integrated floor of exceptional endurance under all normal conditions of wear, enhanced by the matchless decorative beauty inherent in hardwood.

Bradley Unit Wood Blocks protect your workmanship with the highest standards of excellence; available in Oak, Beech and Pecan, finished or unfinished. For your copy of Bradley's Installation Manual, call our local distributor or address:

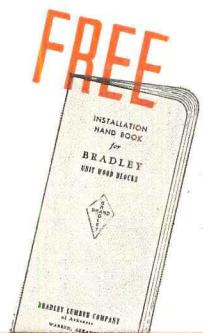

BRADLEY LUMBER COMPANY of Arkansas

*See complete specifications and data in Sweet's Architectural or Builders for 1951.

Dept. F, WARREN, ARKANSAS

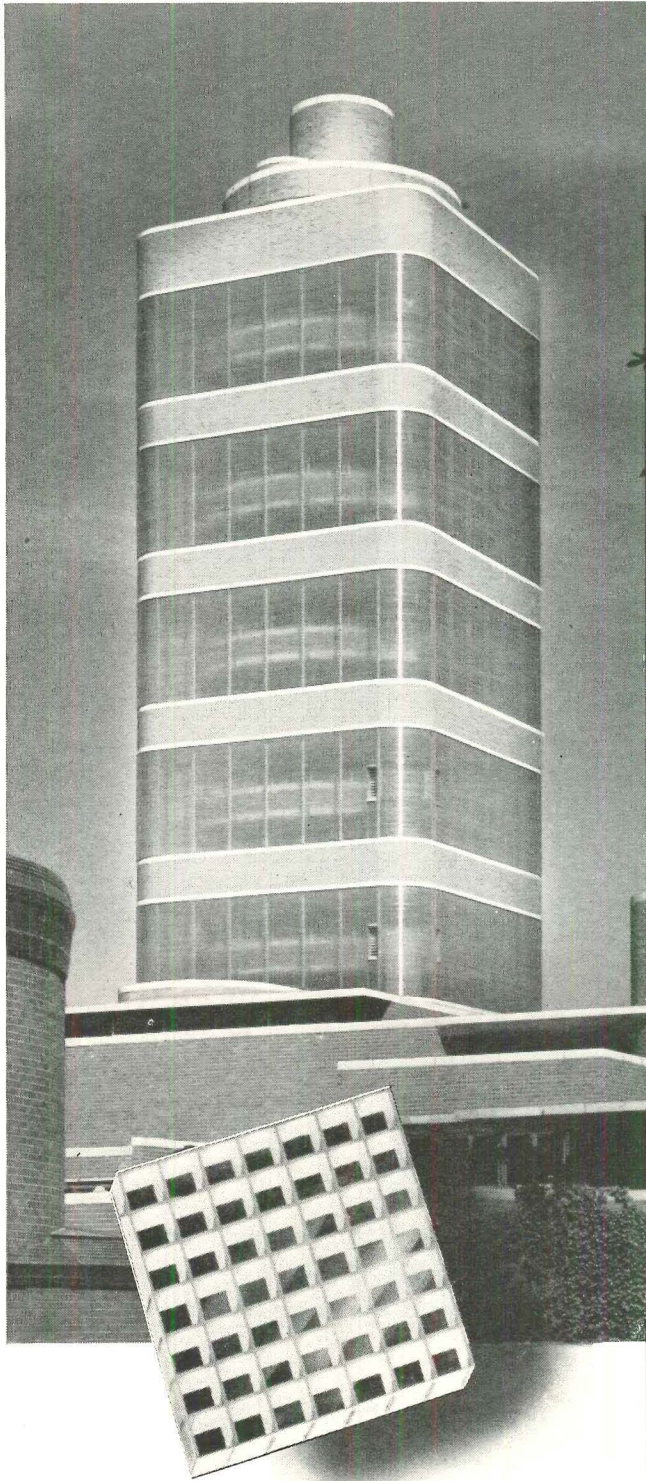

FOTA-LITE combines the advantages of louver lighting with those of diffusing glasses.

CORNING GLASS WORKS
CORNING, NEW YORK

Corning means research in Glass



1851 • 100 YEARS OF MAKING GLASS BETTER AND MORE USEFUL • 1951

IS GLASS BY CORNING IN YOUR BUILDING PLANS—

... for unusual design effects?
 ... for engineered lighting?

Glass has long been used as a structural material—but seldom in the form of glass tubing. When Frank Lloyd Wright first presented this novel idea to S. C. Johnson & Son, Inc., they came to Corning to work out the details. Corning engineers were able to transform the idea into a practical and effective reality. Used originally in the Administration Building and now in their Research and Development Tower, it demonstrates how glass can be used with imagination.

Working hand in hand with architect and builder, Corning devised an entirely new method of mounting and assembly for the tubing. The result is a unique wall that affords all the necessary insulating qualities and yet provides diffuse light to the interior.

In keeping with these unique walls, a remarkable new lighting medium, Corning FOTA-LITE, is used in some parts of the Johnson Building. This is a flat glass with white diffusing louvers permanently embedded by a photographic process. The 45° cutoff is contained within the thickness of the glass itself. It is unusually efficient, easy to clean and attractive.

The moral is this . . . if you have an idea involving a use for glass take it to Corning. You'll get the benefit of 100 years of experience in glass manufacture and application. Bulletin LS-29 will show you how Corning's engineered lightingware can be applied to modern building design. Send for it today.

CORNING GLASS WORKS, Dept. F-1, Corning, N. Y.

Please send me bulletin LS-29 describing Corning's full line of Engineered Lightingware.

Name _____ Title _____

Firm _____

Address _____

City _____ Zone _____ State _____



"A new and remarkable page in Moscow's development"



"... in Smolenkaya Square"

COMES THE REVOLUTION?

Herewith some startlingly bourgeois buildings from the Soviet Union—which had promised to show a better way. The model above, in particular, appears to be a dialectically intriguing blend of two Western buildings: the central section resembles the Chicago Tribune Tower (1925) and the lower portions are not unrelated in form to the Houses of Parliament (1850). Also ponderable is the Marxist purity of the building (below) being given a false exterior solely to cover its proletarian brickwork. All photos, as well as captions quoted, are from Sovfoto.

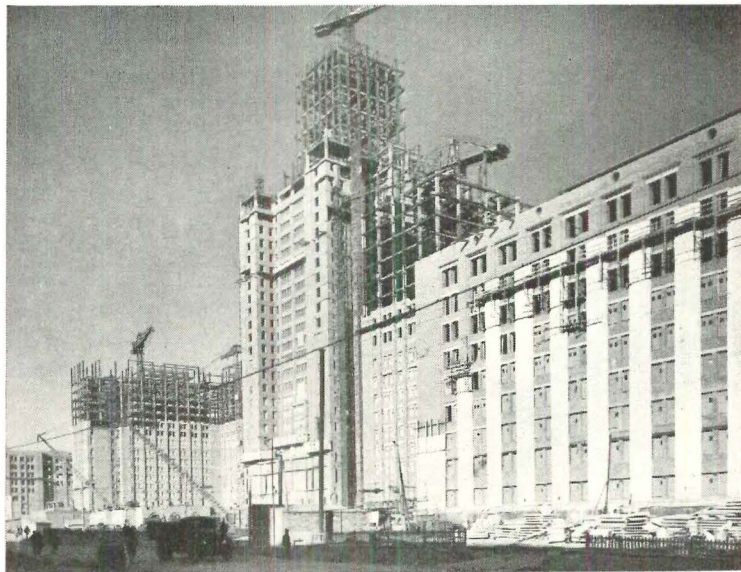

"Moscow State University going up on the Lenin Hills"

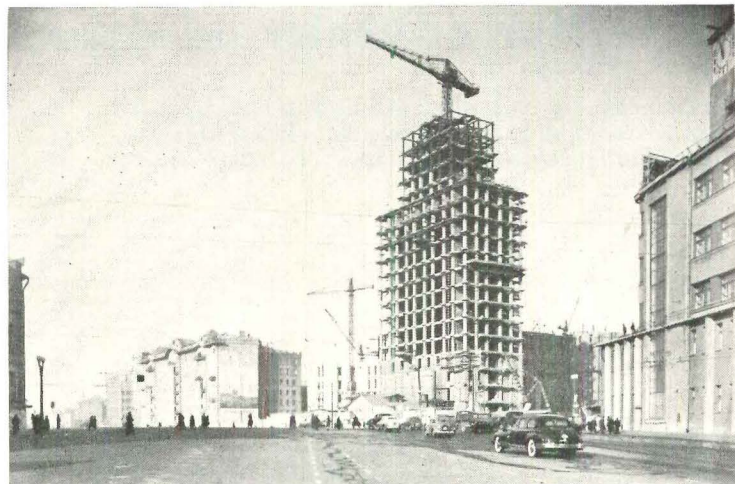

"... near Krasnye Vorota"

of defense housing. Some think it would make sense to take the wraps off Title II in designated places so that the job of relieving the housing pinch could get started immediately. Prediction is that it will take from four to six months to push the new program through Congress and get it rolling. However, Washington officialdom is lukewarm to this suggestion, contending that the Title II approach is at best a clumsy one for this purpose. Besides, the point is made that construction activity will continue to be so high for the next three or four months, while builders are completing the previous program, that they wouldn't be able to tackle any fresh ventures no matter how great the inducement.

Any hopes on the part of the industry that private and public defense housing would be added to the government's goal of 800,000 units for 1951, have been promptly squelched. This means that when allowance is made for the carry-over from 1950 estimated at 360,000 units and defense housing is deducted, there will be slim pickings as far as regular operations are concerned—few brand-new starts in non-defense areas.

INDUSTRIAL BUILDING will expand 25-50 per cent under new tax plan

One branch of building activity that increases rather than decreases during quickened mobilization is industrial construction. Last fall a business advisory group, called in to discuss production problems with the Commerce Department, estimated that to do its part industry would have to spend about \$11¼ billion for building and expansion during 1951. (The 1950 industrial volume barely topped the \$1 billion mark.) But, with the bleak Korean war news, 1951's industrial needs were advanced and government economists now believe that the volume will reach the \$1½ billion level.

Following its usual pattern of never letting one bureau do the job if two or more can be involved, Washington is moving in a variety of ways to sparkplug necessary plant construction. Two direct lending programs are available if a business has trouble raising money on its own. In addition, industries may apply for permission to accelerate the tax amortization of essential new facilities. This is by far the simplest form of assistance that can be obtained and is the one being utilized to the greatest extent.

To qualify for a faster write-off of the cost of a new building, a firm must file an application with the Business Expansion

(Continued on page 25)

Nardin & Radoczny

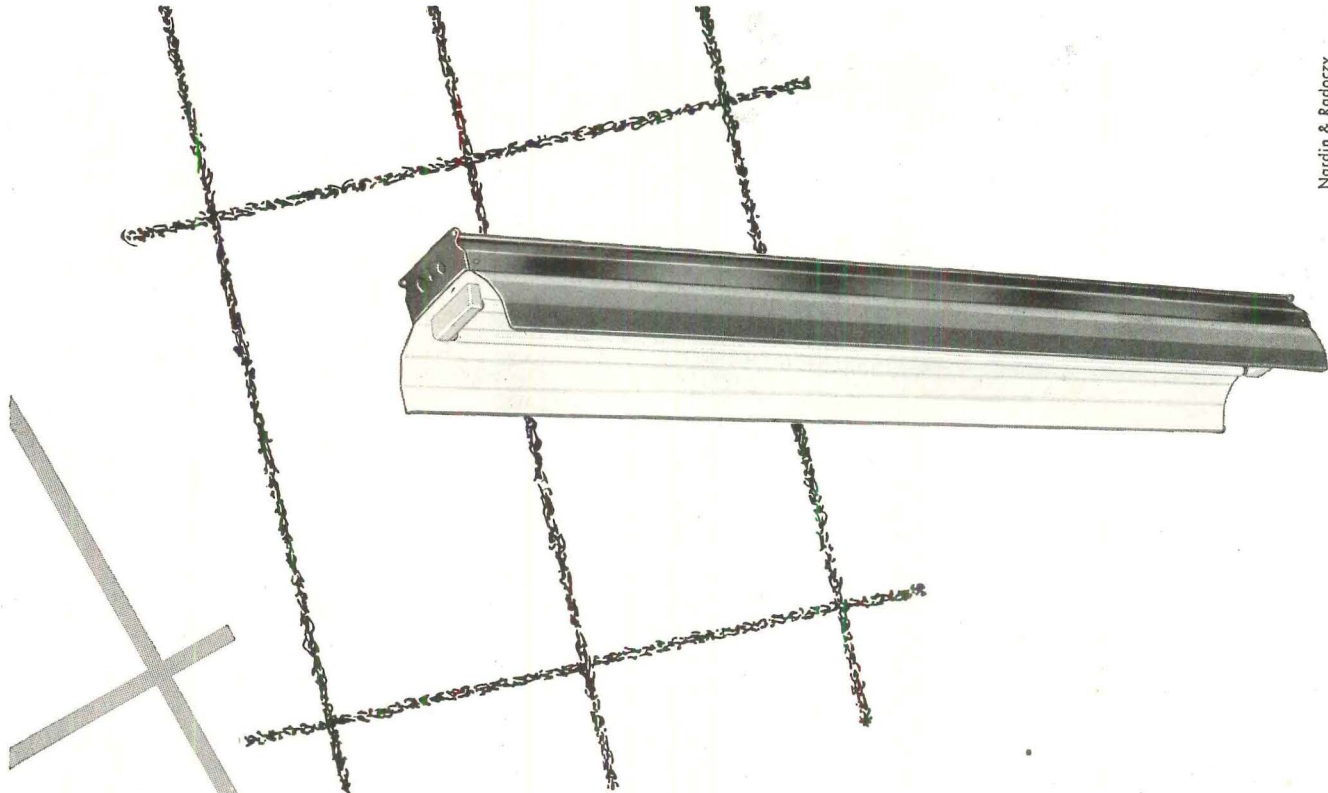

**BEFORE YOU INVEST IN LIGHTING
MAKE SURE OF ITS OVERALL COST**

First cost is only *first* cost—not total cost—of lighting. Cost of installation and maintenance should be considered, too. You must figure all three to get the **OVERALL COST** of your lighting investment.

LOW OVERALL COST is a feature of Miller lighting equipment.

It has engineering features that make for easy installation and maintenance. It is built on an 8-Point **QUALITY** standard which includes rigid "Truss" construction, Bonderite-treated steel and long-life finishes. 107 years' experience in pioneering and progress in Good Lighting is behind all Miller lighting equipment—Fluorescent, Incandescent, and Mercury-vapor—for a wide range of industrial and commercial lighting requirements.

Miller field engineers and distributors are conveniently located for nation-wide service.

THE miller COMPANY MERIDEN, CONN.
SINCE 1844

ILLUMINATING DIVISION: Fluorescent, Incandescent, Mercury Lighting Equipment
HEATING PRODUCTS DIVISION: Domestic Oil Burners and Liquid Fuel Devices
ROLLING MILL DIVISION: Phosphor Bronze and Brass in Sheets, Strips and Rolls

ONLY
Simpson
 QUALITY SINCE 1895
 HAS ALL 5!

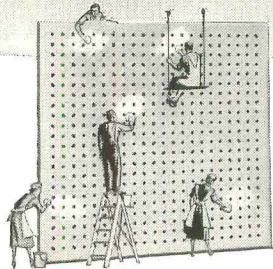
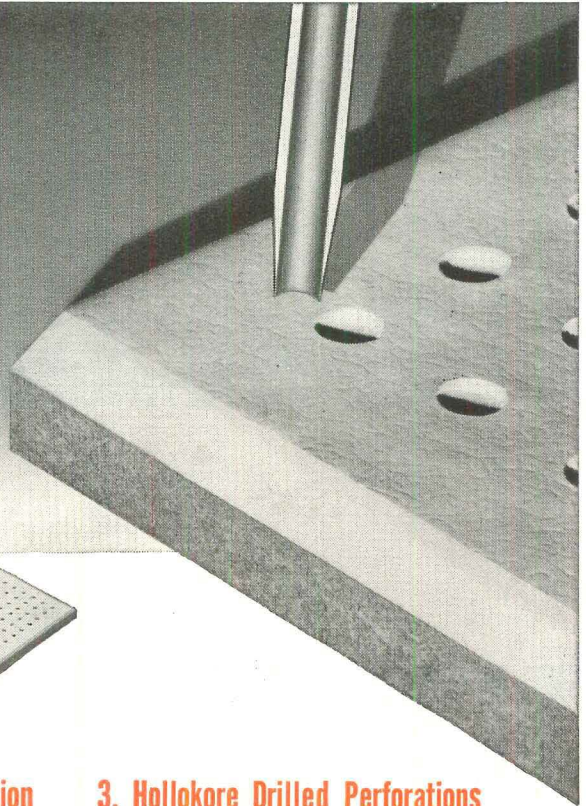

1. Washable Finish

The amazing *washable finish* of Simpson Acoustical Tile can be cleaned by simply using a damp soapy cloth, then rinsing with a cloth dampened in clean water. The sparkling new whiteness is restored!

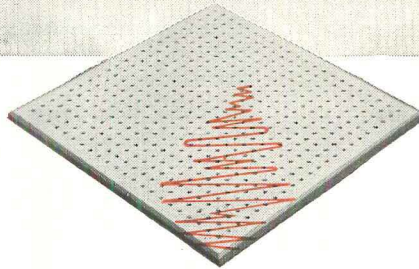

2. Highest Sound Absorption

Independent tests—now backed by the experience of thousands of users—show that Simpson Acoustical Tile has unexcelled sound absorption when compared with other perforated fiber materials thickness for thickness. Simpson Acoustical Tile provides this high efficiency at no greater cost.

3. Hollokore Drilled Perforations

The Hollokore Drill (cross section sketch shown above) developed by Simpson engineers, is responsible for the clean round perforations of Simpson Acoustical Tile. In the enlarged photograph reproduced above, notice the clean-cut holes... no fuzzy edges...no loose fibers to encourage unsightly bridging when repainting.

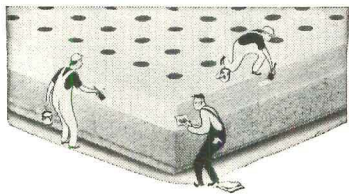

4. Finished Bevels

The same attractive washable white used on the face of Simpson Acoustical Tile is used on the *bevels* of the tiles, adding greatly to the appearance of the finished job... another big reason so many architects specify this material.



5. More Beautiful & Efficient

Wherever there is a noise-quieting problem, Simpson Acoustical Tile will do the job efficiently and will be more pleasing to the eye. It blends with any color scheme, has high light reflection without glare, and highest sound absorption.

Simpson
 QUALITY SINCE 1895
**ACOUSTICAL
 TILE**

FOR BETTER SOUND CONDITIONING

SIMPSON LOGGING COMPANY, Sales Division
 1065 Stuart Building, Seattle 1, Washington

— THESE SIMPSON ACOUSTICAL CONTRACTORS OFFER YOU A COMPLETE ACOUSTICAL SERVICE —

ALABAMA
 Stokes Interiors, Inc., Mobile

ARIZONA
 M. H. Baldwin, Tucson

CALIFORNIA
 Coast Insulating Products, Los Angeles
 Cramer Company, San Francisco and Fresno

CANADA
 Albion Lumber & Millwork Co., Ltd.,
 Vancouver, B. C.

COLORADO
 Construction Specialties Co., Denver

GEORGIA
 Dumas and Searl, Inc., Atlanta

ILLINOIS
 General Acoustics Company, Chicago
 Melvin R. Murdy, Moline

INDIANA
 The Baldus Company, Inc., Fort Wayne

KANSAS
 Kelley Asbestos Products Company, Wichita

LOUISIANA
 Pioneer Contract & Supply Company, Baton Rouge

MINNESOTA
 Dale Tile Company, Minneapolis

MISSISSIPPI
 Stokes Interiors, Inc., Jackson

MISSOURI
 Kelley Asbestos Products Company, Kansas City
 Hamilton Company, Inc., St. Louis

NEBRASKA
 Kelley Asbestos Products Company, Omaha

OKLAHOMA
 Harold C. Parker & Co., Inc., Oklahoma City and Tulsa

OHIO
 The Mid-West Acoustical & Supply Co., Cleveland,
 Akron, Columbus, Dayton, Springfield and Toledo

OREGON
 Acoustics Northwest, Portland
 R. L. Elfstrom Co., Salem

TENNESSEE
 D. E. Madden Co., Inc., Memphis

TEXAS
 Blue Diamond Company, Dallas
 Otis Massey Company, Ltd., Houston

UTAH
 Utah Pioneer Corporation, Salt Lake City

WASHINGTON
 Elliott Bay Lumber Company, Seattle

WISCONSIN
 Building Service, Inc., Milwaukee



an artist with a practical eye

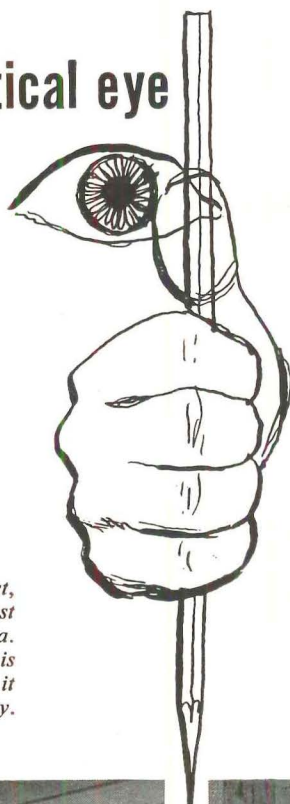

RESIDENCE of Artist Roland Rodegast, in suburban St. Louis, is protected against termites and decay by Monsanto Penta. Lumber used in the interior also is treated with Monsanto Penta to make it water-repellent while retaining paintability.

When Artist Roland Rodegast built his suburban home near St. Louis, Missouri, he combined the beauty of *modern* architecture with the practicability of *modern* wood preservation.

Monsanto Penta (pentachlorophenol, technical), applied by pressure at the rate of six pounds of five per cent penta solution per cubic foot, preserves studding, ship lap and redwood siding. The residence is permanently protected against attacks by termites and other wood-boring insects . . . against decay caused by fungi. Both the beauty and structural strength are protected.

Pecky Cypress, used in the interior, is treated with Wood-tox, a formulation including Monsanto Penta, which makes wood water-repellent and dimensionally stable as well as protecting it against insects and decay. When treated with properly formulated Monsanto Penta, wood can be painted, varnished or beautified with modern finishes.

Monsanto Penta is a permanent wood preservative. It does not leach out of lumber but penetrates deeper as time goes on. It is a chemical treatment that always is uniform, giving *dependable* results.

For suggestions on specifying penta-treated lumber and for information on sources of materials, contact the nearest Monsanto Sales Office or write MONSANTO CHEMICAL COMPANY, Organic Chemicals Division, 1700 South Second St., St. Louis 4, Missouri.

DISTRICT SALES OFFICES: Birmingham, Boston, Charlotte, Chicago, Cincinnati, Cleveland, Detroit, Houston, Los Angeles, New York, Philadelphia, Portland, Ore., San Francisco, Seattle. In Canada, Monsanto (Canada) Ltd., Montreal.

Wood-tox: Registered Trade-Mark of Wood Treating Chemicals Company, St. Louis, Mo.



SERVING INDUSTRY . . . WHICH SERVES MANKIND

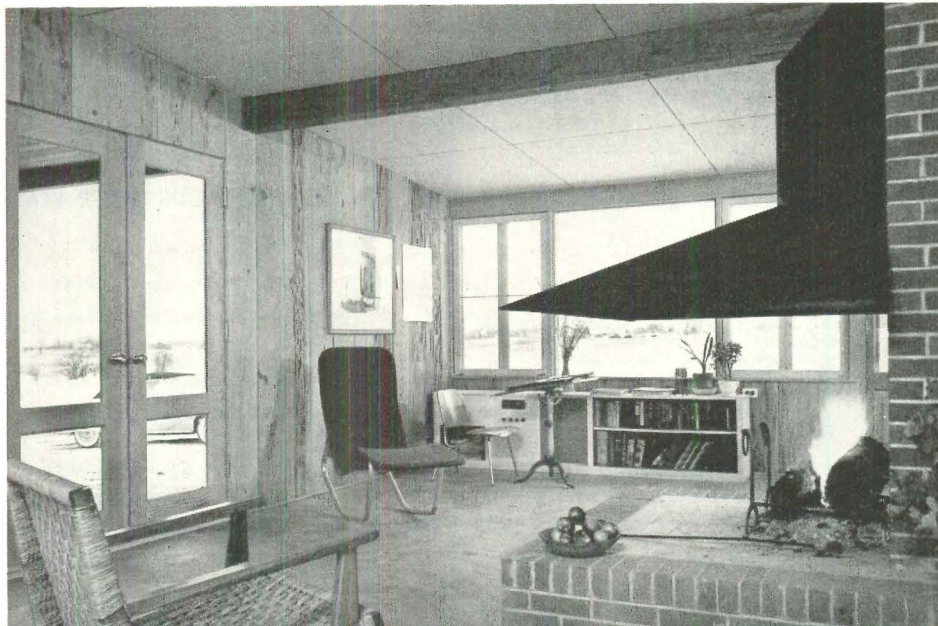

Office of the National Security Resources Board. On this form it certifies that the construction involved is necessary in the interest of national defense. If it succeeds in making its case, it obtains what is known as a certificate of necessity. This permits it to amortize the facilities in five years for tax purposes—the usual rate of depreciation required by the Bureau of Internal Revenue is from 25 to 30 years, depending on the type of building and equipment. So far NSRB has had 700 such requests from virtually every type of business that has a role to play in the defense effort. The initial batch it has approved is largely tied up with steel industry expansion. Twenty separate companies have received certificates of necessity for sums totaling almost \$1 billion. Largest single outlay will be by U. S. Steel for a new \$400 million East Coast mill near Morrisville, Pa. This project alone is believed to be the largest single steel expansion effort in history. The second largest current expenditure for steel expansion will be the \$153 million which Armco Steel Corp. will invest in plants at Ashland, Ky. and Zanesville and Middletown, Ohio. Four other steel producers will invest over \$50 million each—all of them doing it under the accelerated amortization plan.

Location and construction

In giving a plant a nod of approval for stepped up tax depreciation, NSRB has not worried too much as to whether the building would be in a reasonably safe location (not rubbing elbows with other possible targets) and of bomb-resistant construction. But it has the power to get picky in these respects. The present difficulty is that no over-all policy concerning the security factor of plant location has yet emerged.

When and if the time comes for clamping controls on building, a certificate of necessity will acquire added significance. With characteristic caution, officials in charge of the program refuse to be pinned down about a situation until it arises. But they concede that it would be unthinkable for the government to give a project a tax concession because of its bearing on defense production and then balk at allowing it to exert special claims for the allocation of scarce materials.

If a company wants a direct loan to finance a new plant, the first door it must knock at is RFC's. If it can be shown that the money is not available commercially at reasonable rates and if RFC feels disposed to help, it can extend a loan at its current rate of 5 per cent. But if it says no, the

applicant must take hat in hand and tread a truly circuitous path leading first to the NSRB and then to what are termed "designated" agencies. These are the agencies having authority over various portions of the defense production program: NPA for the general run of activity, the Department of Agriculture for foodstuffs, the Department of Interior for mining and oil applications. Under the Defense Production Act, a fund of \$600 million was provided for construction that could not be financed in any other way—including the RFC. The interest rate has been put on a parity with that of the RFC. Congress authorized an additional \$1.5 billion but has not yet appropriated it.

1.3 BILLION DWELLINGS made 1950 biggest year on record

Housing starts during 1950 were close to 1,365,000—an all-time high—according to recent figures on starts during August and November. The August figures are revised totals which move the number of starts upward from an estimated 141,000 to an actual 141,900. Preliminary November figures, however, show a sharp decline, with non-farm housing starts at 85,000, a decrease of 18,000, or 17 per cent, from the previous month. They are also 10,500 below the starts in November, 1949. This is the second 1950 month to be exceeded by the corresponding month in 1949.

However, the large decline was mainly due to bad weather throughout the nation during much of the month. The December figures are not expected to show anything like the same month-to-month decline.

HOUSEBUILDING IN 1951 will include 360,000 units financed last year

The number of houses to be started in 1951 for which financing had been arranged during 1950 is estimated at 360,000 units, according to a preliminary survey made for the HHFA by the industry's Technical Advisory Committee on Credit and Production Statistics. The figure, though somewhat below earlier estimates, is high enough to indicate a fairly strong first quarter in 1951. Approximately 260,000 of the 360,000 units will involve FHA and VA financing. It is also estimated that the same number, though not the same units, will not be subject to Regulation X. Here's how the committee's estimate looks when broken down:

1. The total carry-over of FHA cases for which applications are in process of examination or for which commitments have been issued prior to January is 210,000 dwelling units made up as follows:

One- and two-family houses under Sections 8 and 203: 70,000;

Rental housing exclusive of Title VIII 120,000;

Military housing until Title VIII 20,000. Of these 210,000 units, about 45,000 of the one- and two-family units are free from the October 12 regulations, and about 90,000 of the rental housing and the 20,000 of military housing units are not affected even by the July 18 regulations. Thus approximately three-fourths (155,000) of the FHA carry-over is of "pre-X" status.

2. The year-end carry-over of VA cases, after allowance for duplications with FHA, is estimated to comprise about 90,000 dwelling units, of which probably as many as 65,000 will be eligible for "pre-X" financing.

3. The total carry-over of FHA and VA financing will thus represent about 300,000, of which about 220,000 have "pre-X" status.

4. Commitments for conventional financing of all types of residential building are somewhat conservatively estimated at 60,000 units, at least 40,000 of which will be unaffected by Regulation X.

5. The total carry-over of private financing, therefore, may cover as many as 360,000 units.

6. In addition to the 360,000 privately financed carry-over, the PHA has about 60,000 units at a stage of negotiation sufficiently advanced to make possible their starting during 1951. No restrictions have been placed on 1951 public housing activity.

CIVIL DEFENSE ACT will help finance bomb shelters, dual purpose garages and building reinforcement

A \$3.1 billion civil defense program, operating under a new Federal Civil Defense Administration, is slated to become law as soon as Senate and House differences on the legislation are ironed out.

As now outlined, the plan calls for a vast three-year program to aid likely target areas in preparing for defense against atomic attack—largely through the construction of air raid shelters and buildings which could serve as shelters in an emergency. Two separate sources of money for the project are envisaged: a special civil defense fund, not yet appropriated, and RFC. The special fund would be used to furnish half the cost of community shelters (with the other half being furnished locally), while RFC loans would be granted to self-liquidating projects (like garages)

(Continued on page 29)

air infiltration?

Scientific Testing and Research Provide the Answer on

Auto-Lok

PATENTED
ALUMINUM AWNING WINDOWS

Here is
the report
of the

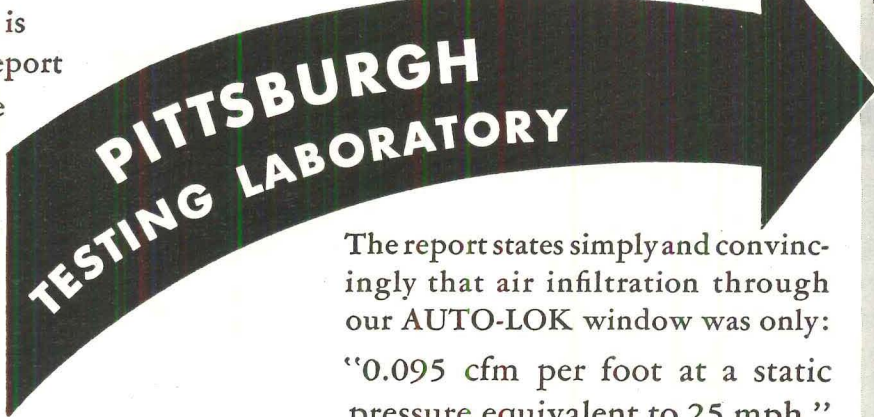

The report states simply and convincingly that air infiltration through our AUTO-LOK window was only: "0.095 cfm per foot at a static pressure equivalent to 25 mph."

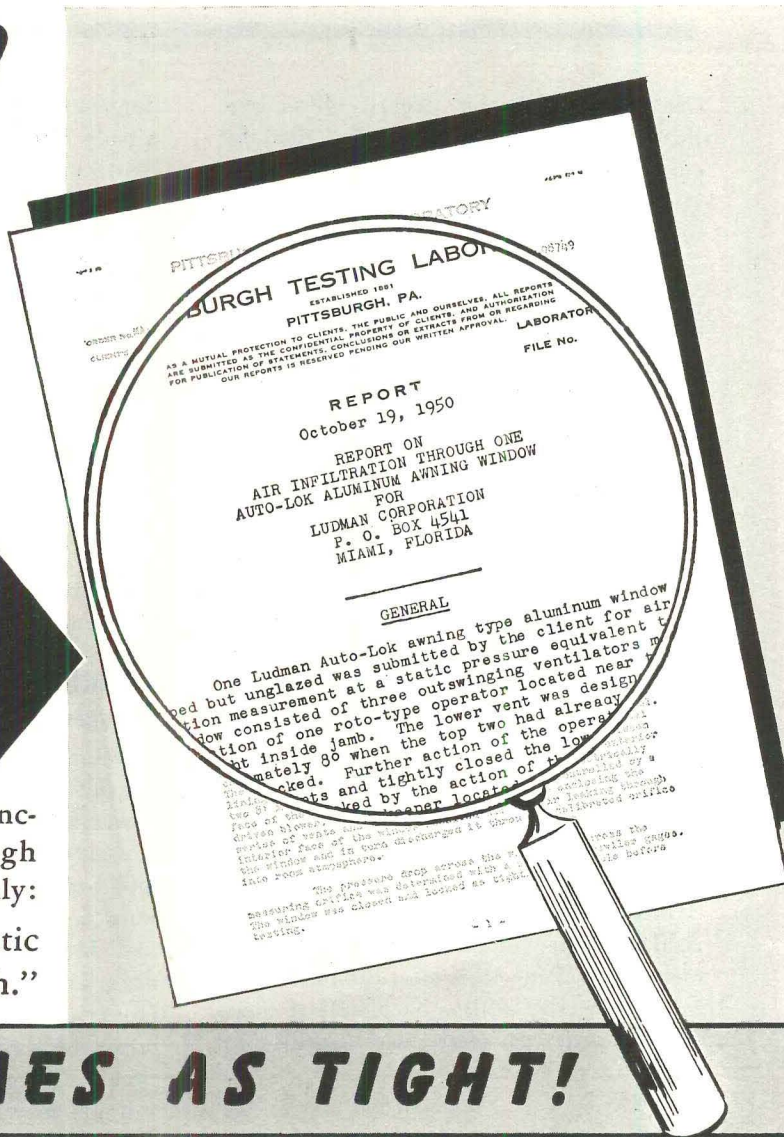

A CLOSURE TEN TIMES AS TIGHT!

Air infiltration of only 0.095 cfm is *amazingly low!* In terms of effective closure it is at least *ten times as tight* as the generally established standards for casement windows and projected sash.

WHAT AUTO-LOK'S TIGHT CLOSURE MEANS:

- reduces air infiltration to a minimum
- eliminates uncomfortable "cold-spots" around windows
- slashes fuel and air conditioning costs
- provides "sealed" protection against driving rain, snow, dust storms and hurricanes

TIGHT CLOSURE, PLUS

- 100% ventilation...even when it's raining
- Draft free ventilation -- air is scooped in and upward
- Cleaning entirely from the inside
- Interchangeable inside screens and storm sash...no tools...just "flip the clips"
- No painting or maintenance
- Precision-balanced finger-tip operation

PATENTED AUTO-LOK HARDWARE

Only patented AUTO-LOK (automatic locking) hardware pulls the vents in tight against the frame -- compressing the elastomeric vinyl weatherstripping against the entire perimeter of each vent. This positive action actually "seals" AUTO-LOK just like a refrigerator.



it's
sealed
like a
refrigerator

LUDMAN

DEPT. AF-1 • P. O. BOX 4541

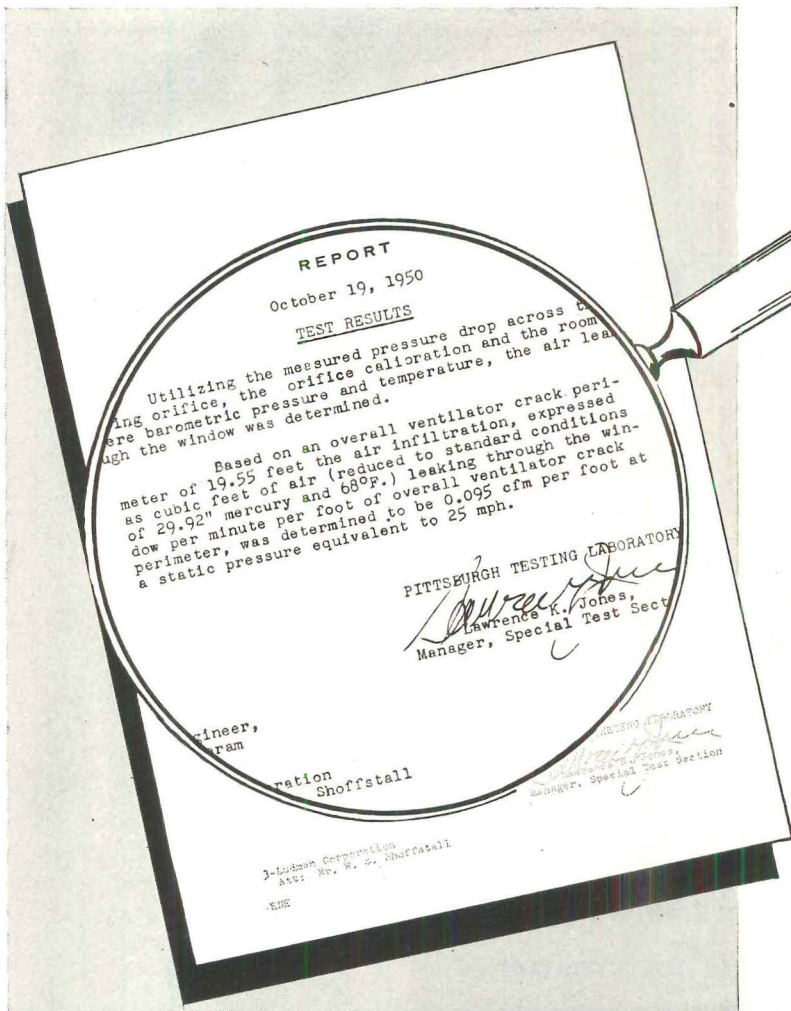

A NEW STANDARD FOR WINDOW PERFORMANCE

When you have available (as you do in AUTO-LOK) a window that closes *ten times as tight* as windows that have been considered "good" in the past, you have... a new standard of window perfection.

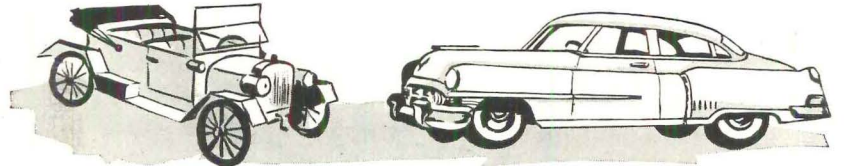

For comparison's sake AUTO-LOK windows are as far ahead of the field as a smartly designed and engineered 1951 automobile in a field of Model T Fords. The Model T was a "good" car in its day... one of the best, but windows, as well as cars, must keep pace with progress, too!

HERALDING A NEW ERA IN WINDOW PERFECTION

MAKE USE OF OUR ENGINEERING DEPARTMENT

Many architects are taking advantage of Ludman engineering service. Ludman's capable engineering staff is called upon daily to solve intricate window problems... they will be delighted to work with you any time!

Auto-Lok

PATENTED

ALUMINUM
AWNING WINDOWS

Corporation
• MIAMI, FLORIDA

SCHOOLS, HOSPITALS, CHURCHES, HOTELS, RESIDENCES

Yes, versatile AUTO-LOK aluminum awning windows fit readily into *any* architectural scheme. They are being successfully utilized in all sections of the nation. You, too, can easily benefit from this widespread, job-proven window engineering experience.

Please examine AUTO-LOK! Compare it! We believe that you'll then agree with architects everywhere that AUTO-LOK gives you *performance... not claims*, and that it is the first and only window to successfully combine the BEST features of ALL window types.

Consult SWEET'S and write for name of your nearest AUTO-LOK Distributor, if you have not received a copy of the informative folder

"WHAT IS IMPORTANT IN A WINDOW?"

Please address Dept. AF-1

LUDMAN CORPORATION

P. O. Box 4541

Miami, Florida

Waterbury

PREFERRED HEATING

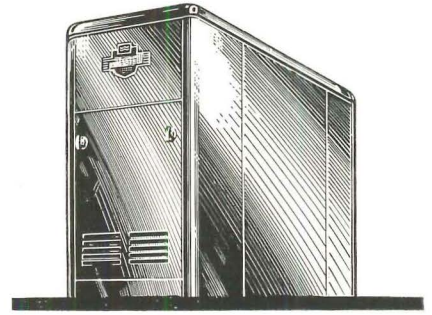

You...

who create better homes—and, we who design the heating to match those homes, have this in common. We sign our names with pride, today as we will thirty years from today. For quality, as some too seldom realize, is not a matter of cost. It is, rather, a strict adherence to that higher plane of craftsmanship and a better awareness of our own abilities. We at Waterbury find our reward in the ever-increasing enthusiasm of the buying public—whenever and wherever Waterbury home heating is mentioned.

MODERN WARM AIR SYSTEMS FOR
ALL RESIDENTIAL DWELLINGS AND
LIGHT COMMERCIAL BUILDINGS...
FOR GAS, OIL OR COAL



THE WATERMAN-WATERBURY CO.
1150 JACKSON ST. N. E. MINNEAPOLIS 13, MINNESOTA

that can serve as emergency shelters. Some of the money will also be used for strengthening existing buildings as potential shelters.

The legislation also calls on the Civil Defense Administrator to stockpile emergency supplies and medical equipment, to train personnel, set up a national air raid warning program, and to help in procurement of fire-fighting equipment.

H-BOMB PROJECTS require new towns—this time by private builders

The ubiquitous atom settled noisily in two southeastern areas last month. First of two announcements by the Atomic Energy Commission was the news that a \$260 million hydrogen-bomb project would be built in South Carolina's Aiken and Barnwell Counties on a 250,000 acre site along the Savannah River. Four small communities were to be eradicated completely, and the nearby cities of Augusta, Georgia, and Aiken, S. C., would also never be the same. A piney woods area given over to scrubby farms, hunting preserves and old estates, the site was selected for its proximity to power resources, its sparse population, and its nearness to several population centers which would supply labor, housing for personnel and local entrepreneurs to build new homes, stores, etc., for plant workers.

Of special interest to the building industry was AEC's emphatic declaration that no government-built town was envisioned. AEC had had its fill of government-controlled atom cities at Oak Ridge, Tenn., Los Alamos, N. M., and Richland, Wash., and was determined to stay out of the housing business. At Oak Ridge, the government had not only provided housing, but also an elaborate bus system, schools, churches and shopping centers—all complex undertakings. They were administered with difficulty and to the satisfaction of few residents. This time the onus was to be on private industry.

Local builders in the area expressed confidence that housing could be provided first for the 8,000 construction workers (some estimates were as high as 20,000) and then for the 7,400 permanent plant personnel. Said Contractor E. Louis Smith of Augusta, Ga.: "The only assistance we need from government is the usual mortgage insurance, help with material supplies, and a general picture of workers' incomes so that we may determine what price house will be in demand."

Since the plant would not be ready for permanent workers for a year and a half, FHA could take its time in shaping policy on mortgage insurance for the area.

Though concerned at first about the new communities' permanency which hinged on peacetime use of the H-bomb's by-products, FHA officials in Washington soon gave assurances that commitments would be forthcoming, particularly in the main centers of Aiken and Augusta where Title II could operate. For the outlying sections, they and local FHA administrators preferred to wait for the newer, more generous terms of the germinating defense housing bill (see p. 17). Since the senior Senator from South Carolina (the state most affected) was none other than Burnet Maybank, chairman of the Senate's Banking and Currency Committee and overseer of all housing legislation in the upper chamber of Congress, measures needed to expedite housing along the Savannah River could expect prompt attention.

AEC's Project No. 2 was a staggering \$500 million "uranium 235" plant to be built on a 5,000 acre site 16 miles west of Paducah, Ky. The recipient of the biggest government contract ever awarded to one construction firm, F. H. McGraw & Co. of Hartford, Conn., will handle factory construction. Here, too, AEC plans no government town for the 10,000 construction laborers and 1,600 permanent workers needed to build and run the plant.

In Aiken, Augusta and Paducah, local builders were feverishly making plans and scrambling for land (prices in Augusta had tripled) along with builders from all parts of the country. Among them, Gunnison Homes, Indiana prefabricator-subsidary of U. S. Steel, announced that its dealers were erecting 100 houses in Paducah and 10 in Aiken to sell from \$7,000 to \$9,400, including lot.

Despite local optimism, however, HHFA feared that local builders were too small to meet the new housing need in both places, suspected also that community services (sewage lines, schools, stores, etc.) would be taxed to the breaking point by the rapid expansion. The single, integrated community that was neither government town nor privately-built hodge-podge was already under active consideration by several big outside builders. To protect them from speculators, Congressmen were wondering if the defense housing bill should not empower AEC to acquire land near the projects for sale or lease to the builders.

WAR DAMAGE INSURANCE will aid building owners and mortgage lenders

None too soon for the jittery fringe of mortgage lenders and property owners, Congress decided last month to face the issue of writing a new war damage insur-

ance bill. There were reports from New York—no doubt a trifle exaggerated—that financing for new skyscrapers had virtually dried up because lenders balked at the risk of having the collateral blown to smithereens without some assurance of indemnity. West Coast builders and lenders were known to be apprehensives. But while the "lame duck" session made a valiant effort to plod through with the legislation it could not quite make the grade. The new 82nd Congress will have to start again from scratch.

What was proposed was a relatively simple bill reactivating the War Damage Insurance Corporation, set up in the RFC during the last war. The bill authorized the RFC to use up to \$1 billion of its funds to underwrite the new program with the provision that Congress would appropriate additional money when it was needed. The premium rate was left to the RFC. It was stipulated, however, that the coverage cost should be uniform for the same type of building regardless of location. Beyond these broad terms no attempt was made to spell out the procedure except that it was made clear that the insurance would also cover damage inflicted by our own forces in repelling an attack.

Private enterprise help

Presumably the RFC would shop out the work to the regular insurance companies as it did last time. But all realized that, except for the bookkeeping operations, there would be little similarity between the two programs. With only negligible losses, the old War Damage Insurance Corporation plowed back into the treasury a \$210,000,000 profit. It only charged a piddling premium—10 cents a \$100 on real and personal property. The new program will be a different kind of an animal altogether. Not only is there greater chance of an enemy getting through but the damage that he could inflict will be incalculably greater. In fact, insurance company executives conceded in testimony before the House Banking Committee that there is no actuarial basis for figuring the risk. One guess is that the RFC will at least double the premium rate.

The assumption is that lenders generally will follow the same practice they did during the last war—insist that borrowers take out war damage insurance as a prerequisite to getting a new mortgage. Some of them actually went a step further. Where mortgage agreements already in force gave the lender the right to insist on "adequate" insurance protection they interpreted the language broadly enough to include war damage coverage.

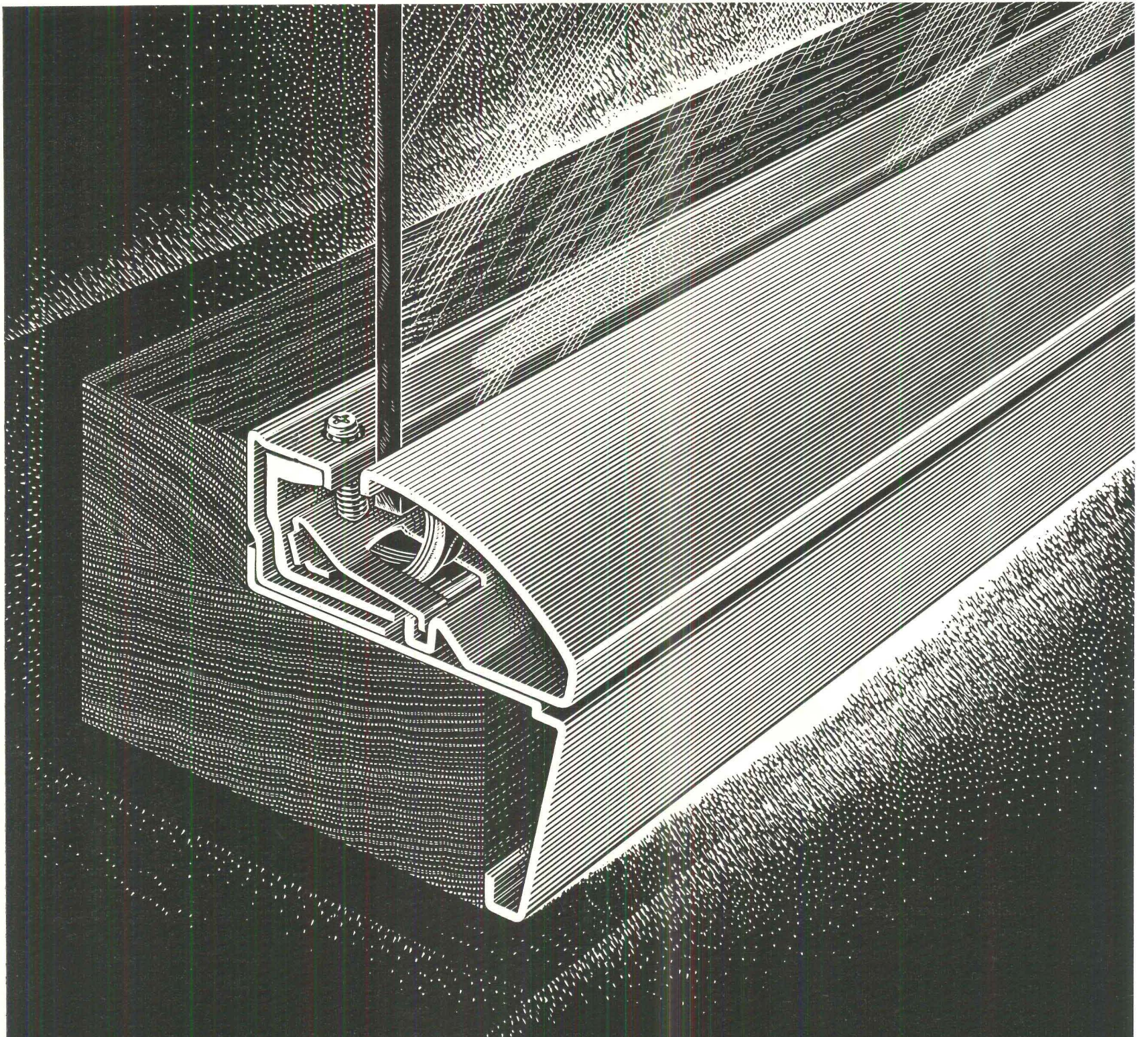

NEW KAWNEER STOCK SASH
CUSTOM-STYLED FOR
MODERN ARCHITECTURE



UNEQUALED IN PRECISION ENGINEERING AND WORKMANSHIP

Striking simplicity in styling and sound construction make this Kawneer Assembly one of today's truly outstanding architectural metals.

The graceful curve of the sash, the dramatic shadow-line, and the clean plane of the sill create a visual unit which meets the highest standards of contemporary design.

Like all other Kawneer Glazing Assemblies, this Sash incorporates the famous Kawneer resilient-grip principle which insures maximum safety and reliability. The resilient steel spring-clip

minimizes breakage due to sudden blows, strong winds, and normal structural settling.

For further information and details, write The Kawneer Company, Department MB-60, 1105 North Front Street, Niles, Mich., or Department MB-60, 930 Dwight Way, Berkeley, California.

THE
Kawneer
 COMPANY
 ARCHITECTURAL METAL PRODUCTS
 Store Front Materials
 Aluminum Roll-Type Awnings • Modern Entrances
 Aluminum Facing Materials • Flush Doors

"I'm sold on
electric hot water..."

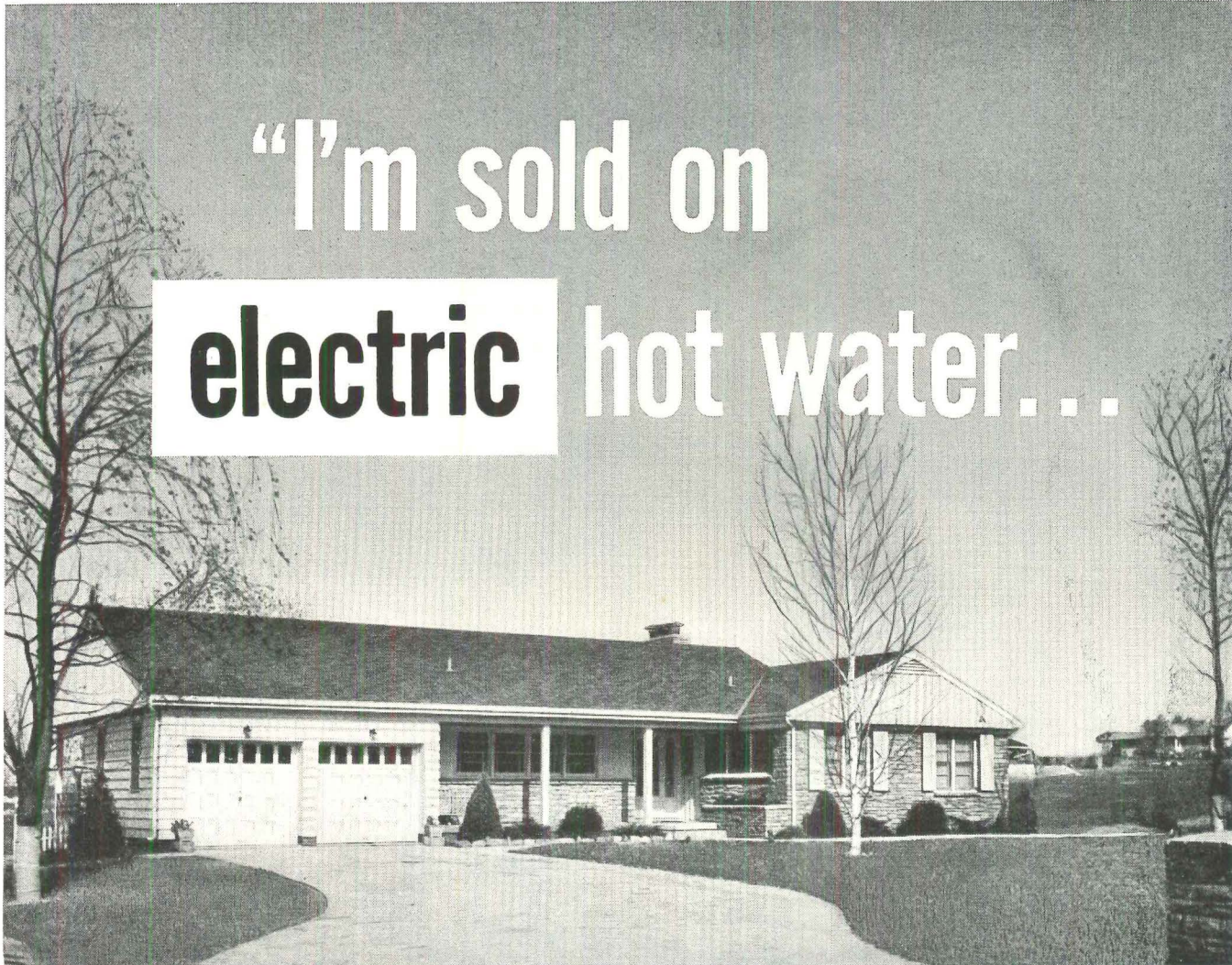

"and so are my customers," says builder
 A. S. "Tony" Battiato, of Omaha, Nebraska

"If your houses include the kind of equipment that home buyers prefer, then selling's easier. Electric Water Heaters are that kind of equipment."

Here's why Electric Water Heaters are "that kind of equipment." They're clean and trouble-free. They're built for long life. They're economical in operation. They keep water at the desired temperature in their fully insulated tanks. And their all-electric, dependable temperature control assures safety.

It pays builders to install Electric Water Heaters because this type is economical for builder and customer alike. There's no flue or vent, so installation can be made anywhere. This shortens hot water lines, cuts piping cost, prevents water waste.

Equip Your Homes with
automatic electric water heaters

They're what people want!

ELECTRIC WATER HEATER SECTION National Electrical Manufacturers Association, 155 East 44th Street, New York 17, N. Y.

ALLCRAFT • BAUER • BRADFORD • CRANE-LINE SELECTRIC • CROSLY • DEEPFREEZE • FAIRBANKS-MORSE • FOWLER • FRIGIDAIRE • GENERAL ELECTRIC
 HOTPOINT • HOTSTREAM • JOHN WOOD • KELVINATOR • LAWSON • MERTLAND • MONARCH • NORGE • PEMCO • REX • RHEEM • SEPCO
 A. O. SMITH • THERMOGRAY • TOASTMASTER • UNIVERSAL • WESIX • WESTINGHOUSE

▲ Mr. Battiato installs Electric Water Heaters as standard equipment in all his houses. As proof of resulting consumer appeal, his last group of \$12,000 homes—eighteen in all—were sold before they were finished. Why not have this selling help in the houses *you* build?

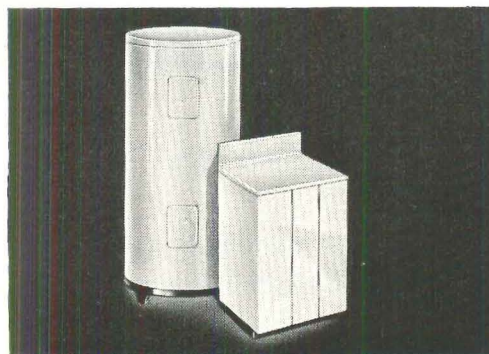

VIRGINIA METAL PRODUCTS...



*Keep pace with VMP
... and progress*

You will want to have these completely new and up-to-date Catalogs on your desk, for they give you the very latest developments in:

- Library Bookstack Equipment—Catalog A
- Hollow Metal Doors and Frames—Catalog B
- Mobilwalls, Movable Steel Partitions—Catalog C

These descriptive Catalogs on VMP products show you how to get the maximum effectiveness from VMP quality products. Send for your personal Catalog today.

VIRGINIA METAL PRODUCTS CORP.

Product Information Dept.

60 HUDSON STREET, NEW YORK 13, N. Y.

Please send me a personal copy of your Catalog

A

B

C

Name _____

Firm _____

Address _____

City _____ State _____

COMPLETE CATALOGS FILED
IN SWEETS' BUILDERS' AND
ARCHITECTS' FILES

MOBILWALLS • BOOKSTACK EQUIPMENT • MOBILSCREENS • CONVEYORS • MOBILRAILS • DOORS AND FRAMES

A city within a city...

HEATED BY 15 GAS FIRED

KEWANEE STEEL BOILERS

● "Stonestown," in San Francisco's famous Lake Merced section, is actually a City within a City. This \$20,000,000 development with its fourteen apartment buildings provides homes for 700 families, plus a 40 acre business and shopping area with parking space for 2500 cars.

Heat, plus ample hot water for kitchens, bathrooms and laundries, is provided by 15 Kewanee Steel Boilers equipped with Kewanee Submerged Tankless Hot Water Coils... another typical example of an outstanding modern project where Kewanee was selected for dependable, economical heat.

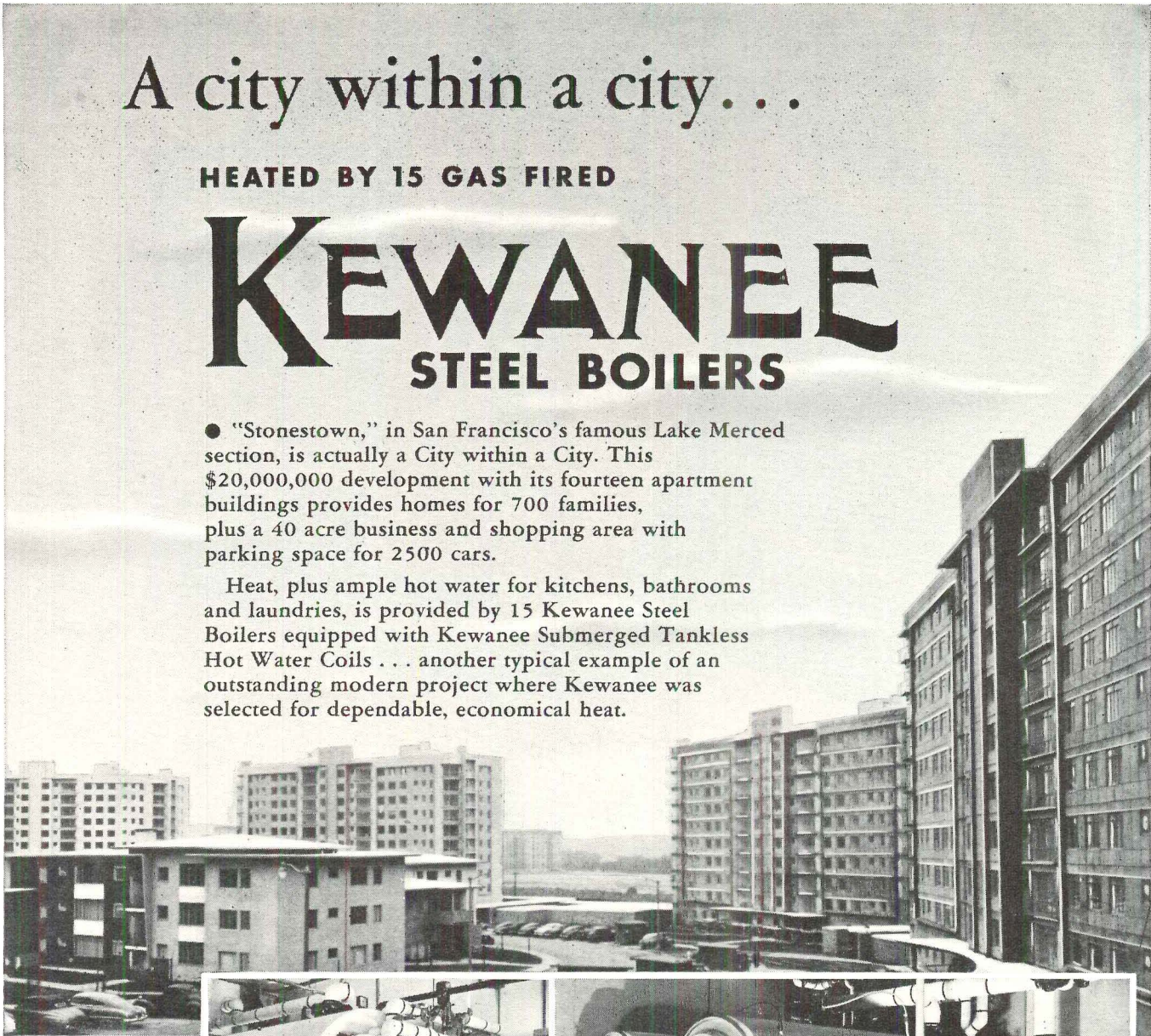

"STONESTOWN"
Apartment Project
San Francisco, Calif.

Architect:
ANGUS McSWEENEY
Burlingame, Calif.

Engineer:
C. H. BAZILLE
San Francisco, Calif.

Heating Contractor:
L. J. KRUSE CO.
Oakland, Calif.

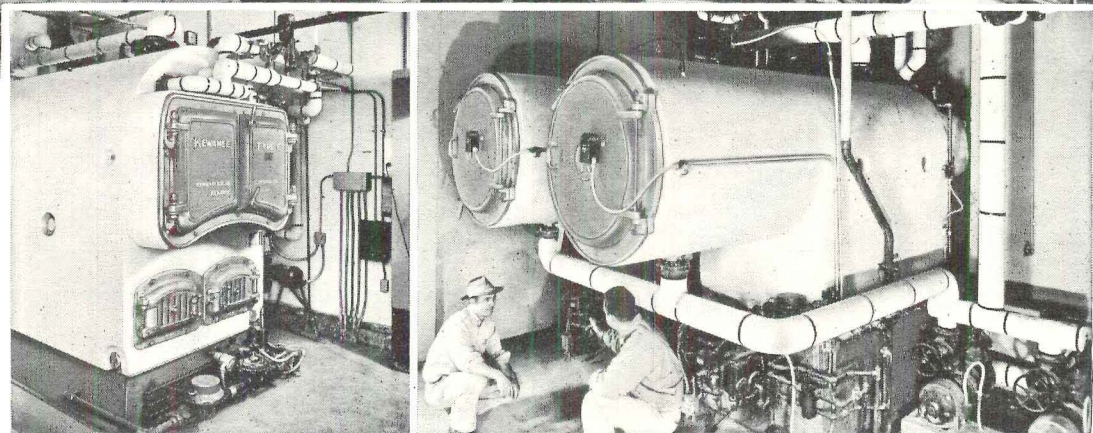

See Our Exhibit . . . Space A
10th International Heating & Ventilating Exposition
January 22-26 — Philadelphia

● A view of two boiler rooms showing three of the 15 Kewanee Steel Boilers installed in the Stonestown Project. With a total output of more than 24 million Btu, these boilers provide both heat and domestic hot water for the entire project.

KEWANEE BOILER CORPORATION

BOILERMAKERS 80 YEARS KEWANEE, ILLINOIS

Branches in 60 Cities — Eastern District Office: 40 West 40th Street, New York City 18

Division of AMERICAN RADIATOR & Standard Sanitary CORPORATION

Serving home and industry

AMERICAN-STANDARD • AMERICAN BLOWER • CHURCH SEATS • DETROIT LUBRICATOR • KEWANEE BOILERS • ROSS HEATER • TONAWANDA IRON

PUPILS DON'T HAVE TO CATCH COLD



This room without DRAFT|STOP presents a problem of uneven temperatures

LET **DRAFT STOP** CATCH IT!

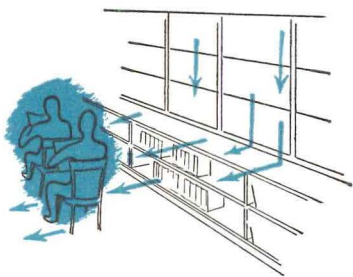

DRAFT HAZARDS are ever present in this classroom. Above you see how cold air travels unbindered, presents a cold front problem of discomfort and possible illness.

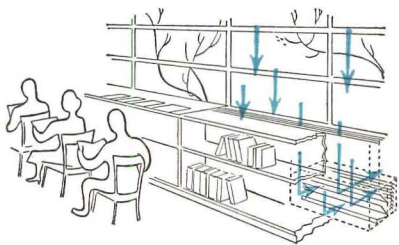

MODERN VENTILATION with the new DRAFT|STOP System ends this threat. See how drafts and cold air are controlled. DRAFT|STOP will stop the draft before it can start trouble.

CHILDREN in schoolrooms don't have to withstand chilling down-drafts when new DRAFT|STOP is in service. The new DRAFT|STOP System, developed by Herman Nelson, traps drafts to protect the health and comfort of pupils in classrooms. By introducing the proper amount of fresh air automatically, stuffy air and overheating are eliminated; students are alert and more receptive.

This new concept of better ventilation, new as the year 1951, is necessary for assured comfort and welfare of children. Whatever your connection with the equipment installed in schools, make certain DRAFT|STOP is specified.



**TODAY'S BEST
BUY IS BETTER AIR**

WRITE TODAY for this new booklet explaining the vast difference—advantages obtainable only with the new DRAFT|STOP System. Write Dept. B-1.



HERMAN NELSON

Division of **AMERICAN AIR FILTER COMPANY, INC.**
PLANTS IN MOLINE, ILLINOIS AND LOUISVILLE, KENTUCKY



SCHOOL BOARD SUPERINTENDENT

How to build the schools we need on our budget?



SCHOOL PRINCIPAL
How to handle an increasing enrollment without additional space?



SCHOOL ARCHITECT
What features to incorporate that will make the building completely efficient?

Multiple-Use-of-Space Answers All Three Problems

With *In-wall* equipment an activities room can be converted to a lunchroom for 200 in eight minutes. Lunchroom space and table and chair storage space are eliminated. Now in satisfactory use from coast to coast.

WRITE FOR CATALOG



In-wall

**FOLDING TABLES
AND BENCHES**

ALREADY SPECIFIED BY 85% OF ALL
LEADING SCHOOL ARCHITECTS IN NEW
BUILDING AND REMODELING PROJECTS.

★
SCHIEBER MANUFACTURING CO.

12,738 BURT ROAD
DETROIT 23, MICHIGAN

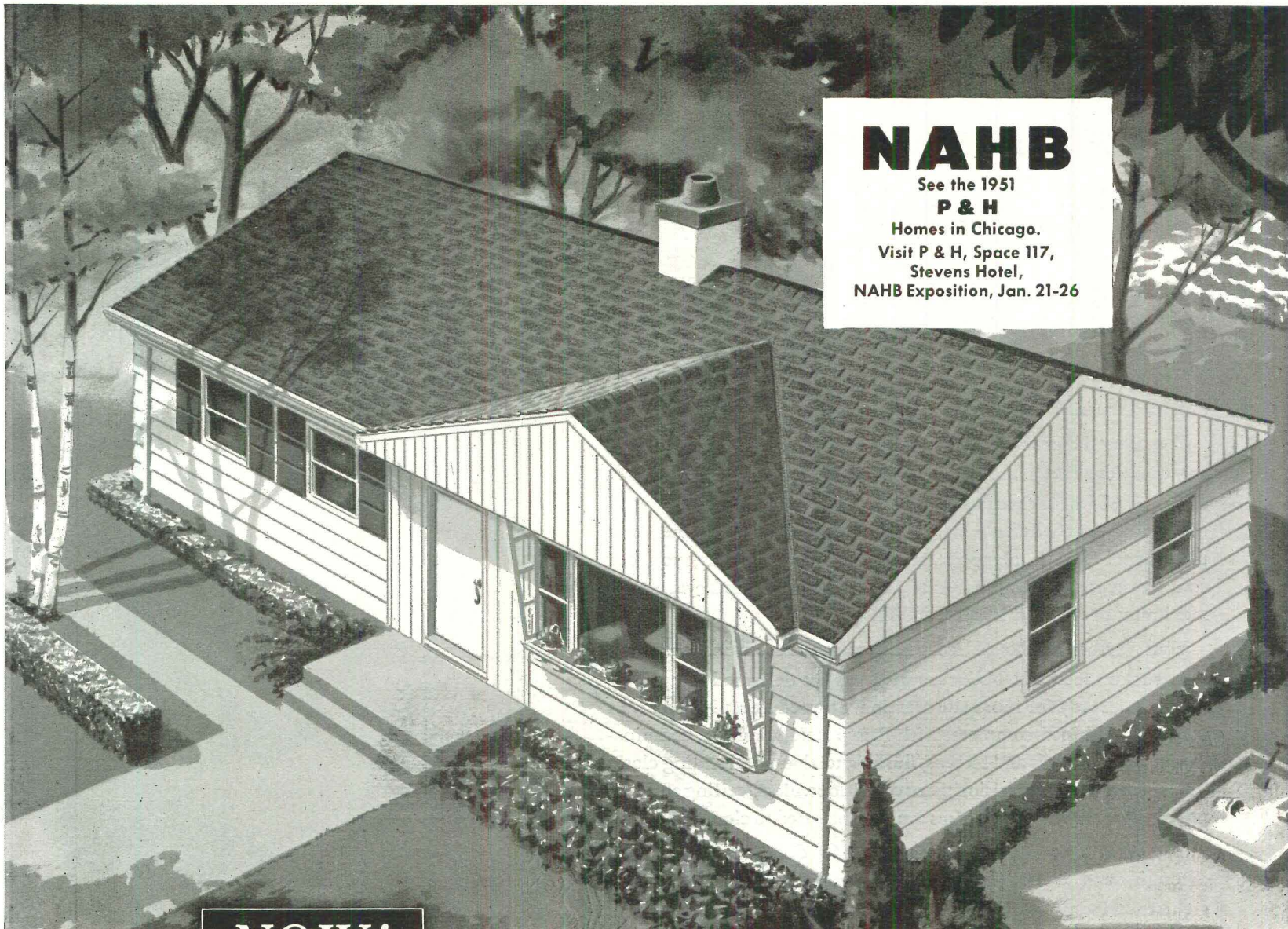

NAHB

See the 1951

P & H

Homes in Chicago.

Visit P & H, Space 117,

Stevens Hotel,

NAHB Exposition, Jan. 21-26

NOW!

P & H

*shows you how to win
on the 1951 Home Front*

You can fill your community's emergency housing needs with permanent homes designed for a lifetime of living, when you choose P&H factory-engineered homes. Your projects gain the infinite individuality possible only with the 60 P&H elevations and five basic sizes. Yet you share the "across the board" savings of prefabrication, and meet all current government regulations.

BUILDERS—Know your costs. Be sure of profits, even in today's uncertain market. Enjoy volume sales with minimum risk. Get maximum turnover on your money. End your supply problems. Build on schedule. Save at every point.

MANAGEMENT—Get attractive, permanent employe housing in a hurry. Select P&H homes for rental or worker ownership, without incurring "company housing" liabilities.

FINANCIAL AGENCIES—P&H home projects offer you a continuing source of sound mortgages on new, permanent homes, priced to meet current government loan curbs.

TURN THE PAGE FOR THE 1951 P & H "HOME FRONT" WINNERS ➤

NOW!

P & H offers you
*unlimited variations,
for 5 homes or 500*

Never before could home builders and project developers of every size enjoy *big project* advantages. Now P&H offers you a sure source of low cost homes, with proven sales appeal. Builders everywhere are turning to the first truly adaptable prefabricated home—designed for individuality and variety in projects of 5 homes or 500.

You can sell homes priced for every volume market—selected from the complete P&H line of five basic models, with floor areas of 672, 768, 864 or 960 square feet. You can offer two bedrooms or three, full basement or none, left hand plans or right, and "end placement" models planned for narrow lots. In short, you can convert the maximum number of prospects into home buyers, with maximum profits and minimum risk.

Your "across the board" cost savings result from modern P&H construction methods. Major components are delivered completely assembled, ready for rapid site erection. Stressed skin plywood wall panels are shipped complete, with Rusco steel windows, combination storm windows and screens, flush panel doors and sliding closet doors—fitted under precision plant conditions. Floor, ceiling and roof panels, roof trusses, floor beams are all fabricated to close tolerances.

You gain maximum individuality — 60 different elevations — through such P&H special features as gable and hip porches, trellises, window boxes, extra-wide eaves, classic panels, shutters and door designs. Whole blocks gain variety in texture and color when you apply horizontal and vertical sidings, clapboards, or brick or stone veneer. No other prefabricator offers such design flexibility.

Loan agencies and building officials recognize the lifetime value and solid durability of P&H construction—backed by Harnischfeger Corporation's 67 years' experience in building quality products. And — if local funds are limited — you can get construction loans or long term financing through Harnischfeger's subsidiary, the Builders Acceptance Company. Write today for details of the P&H Builder Profit Plan.

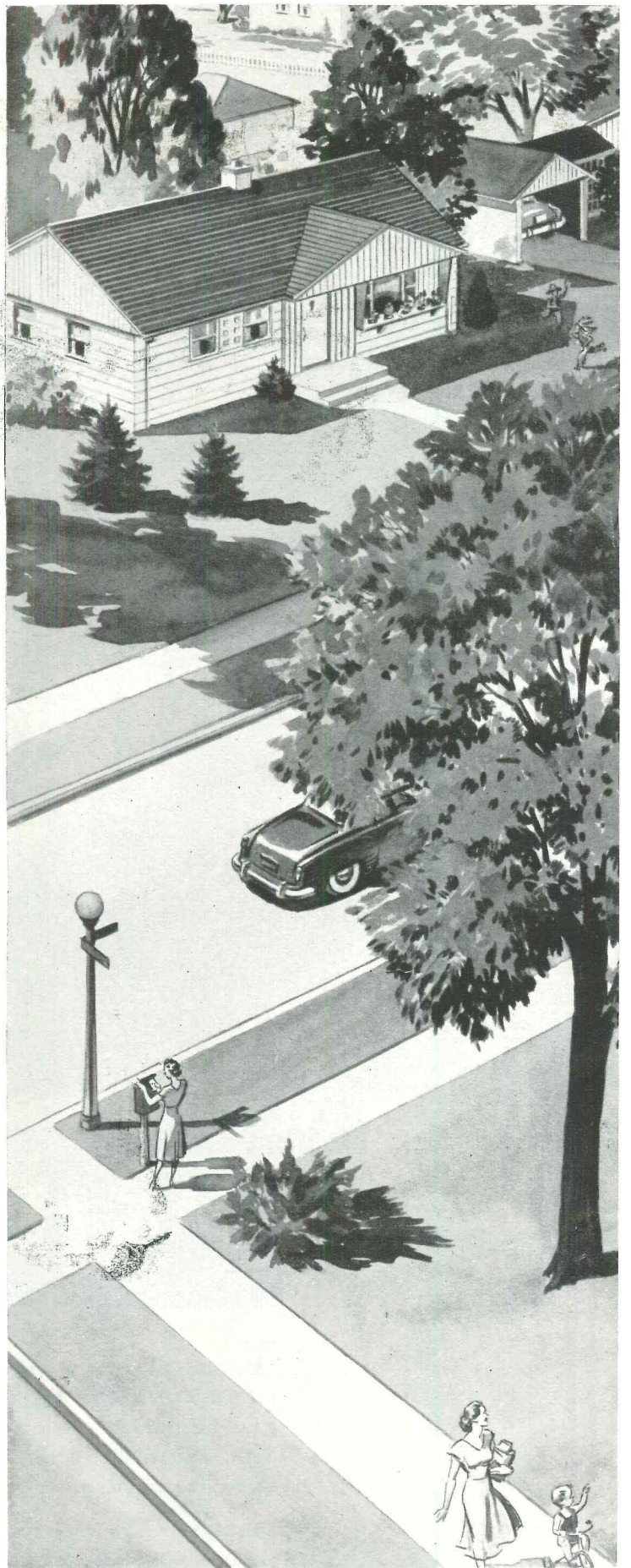

P & H Harnischfeger Corporation

HOUSES DIVISION

61 Spring Street • Port Washington, Wisconsin

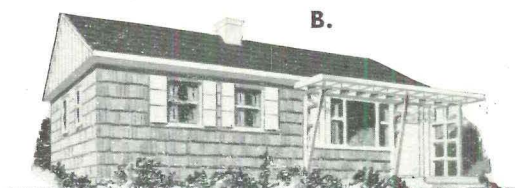
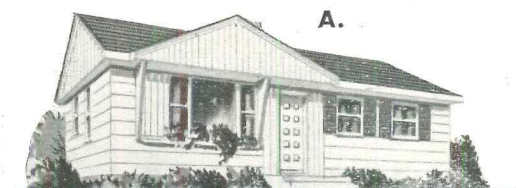

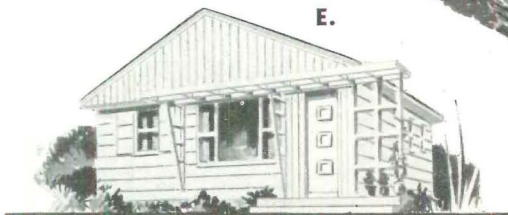
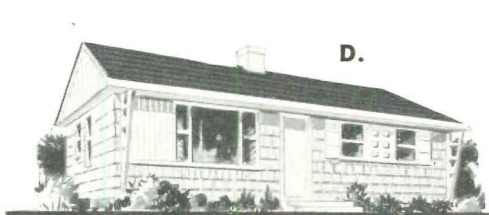

SPECIAL FEATURES

- A. Gable, Jib, Window Box
- B. Trellis, Clapboards
- C. Hip Perch, Classic Panels
- D. Full 33 1/2" Overhang
- E. Narrow Lot Placement.

THE ONLY FORM FOR STEEL JOIST CONCRETE FLOORS AND ROOFS Corruform

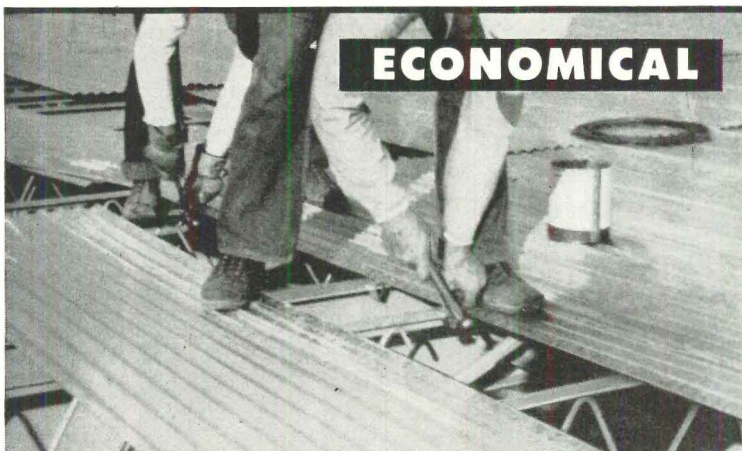

ECONOMICAL

CORRUFORM sheets are easily placed. Fasteners are positive for all common joists and beams. Lapping is automatic. No sag or material waste. Concrete is placed and finished by common practice.



SAFE

CORRUFORM is nearly twice as strong as ordinary steel of equal weight. Tough tempered to spring back under abuse. Provides a secure form for trades and concrete—no side pull on joists, beams, or walls.



CLEAN

CORRUFORM is true and level. No cleanup necessary on floors below, no unsightly leakage. Bright, decorative corrugated pattern for exposed ceilings. Corruform is available plain, galvanized or vinylprimed for painting.

SPECIFICATIONS

Standard weight Corruform with 2 3/16 inch wide, 1/2 inch deep corrugations. Weight .72 lbs. per sq. foot. Guaranteed average strength of 100,000 psi.—single test minimum strength 95,000 psi.

GRANCO STEEL PRODUCTS

(Subsidiary of GRANITE CITY STEEL CO.)

Granite City, Illinois

SEND
FOR
FREE
AIA FILE
TODAY

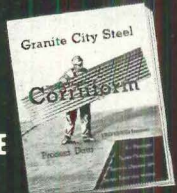

LETTERS

UN BUILDINGS

BUILDING:

Percival Goodman thinks very little of the UN Secretariat (*BUILDING*, Nov. '50, p. 103), particularly on the basis of "function, psychological and physical." As one who has worked in the old League of Nations buildings and who now works in a UN Specialized Agency whose headquarters are, in many respects, a junior-sized copy of the Secretariat building, let me examine Mr. Goodman's proposed alternatives to a building whose 600 ft. height makes it "not functional except in terms of land speculation."

Goodman alternatives 1 and 2 involve either a 12-story, six-block-long building or a gigantic two-story rectangle with "three or five slender prisms." If Mr. Goodman, in his quest for functionalism, had examined the function of the UN Secretariat, he would have realized that the inter-play of UN work involves constant meeting and discussion among Secretariat members in different divisions and sections. My average day, for example, involves my seeing many people, either in my office or theirs; will Mr. Goodman provide me with a motorcycle for communication along his six-block-long corridors, or a helicopter to transfer me from prism to prism? Personally, I believe Mr. Harrison's banks of high-speed elevators—assuming that they are sufficient—will be much easier on my shoe soles and my patience.

Suggestion 3 involves the use of duplication of the old League of Nations building in Geneva. Architecturally, the story of the Geneva buildings is unfortunate enough; certainly the rabbit-warren of corridors and offices whose inhabitants may be able to speak to one another out of their windows, but may have to travel around corners for three or four blocks to reach one another physically, could hardly be considered functional.

Personally, I like the UN building: personally, Mr. Goodman is entitled to dislike it. But if he were sentenced to spend one month in Geneva, I think he might then agree that a new architecture can—and does—create new ideas.

SYDNEY G. COOPER
Montreal, Canada

BUILDING:

None of your critics has mentioned the most important aspect of the UN building.

It is wonderful to know that a group of architects from many nations can, as a group, design *any* building, and that that building should be a great building is nothing short of miraculous. Nevertheless, I should like to suggest that the greatest significance of this building is its expression of a new approach to architectural design.

The men who designed the UN building see cities like New York as crowded patches of
(Continued on page 47)

Every Plastic advantage at a moderate cost!



design
function

■ **Vinylite Colors:** FLOR-EVER features the clean, lucid colors typical of plastics—whiter whites; blacker blacks; luscious reds, greens, blues and yellows, with marbelized mixtures. There are, today, 21 FLOR-EVER colors. A set of samples is freely available to every accredited architect, designer or builder.

■ **Tiles and rolls (plus feature strips):** FLOR-EVER is available by the YARD (in six widths: standard 6-foot, plus 42", 36", 30", 24" and 9") AND in 9" x 9" TILES, AND in 1" feature STRIPS. Thus your designing scope is unlimited. Furthermore, FLOR-EVER is also an ideal sink or counter top and is made in the right widths for such use. You can now design with all major horizontals matching perfectly.

■ **Non-Porous—cuts cleaning care:** FLOR-EVER is NON-POROUS—which means that soil cannot grip *into* the surface and therefore is removed with far less effort.

■ **Grease-proof, alkali-proof, water-proof.** No animal, vegetable or mineral oil, grease or fat can ever stain, soften or in any other way damage FLOR-EVER. The harshest soaps, cleaners and detergents will not affect it.

■ **Stain-and-spot-resistant.** FLOR-EVER is almost completely inert and stable chemically—cannot be stained, discolored nor in any other way affected by household acids, chlorides, bleaches and other attacking agents normally encountered.

■ **Outwears most other floor coverings.** FLOR-EVER is amazingly resistant to abrasion. For instance, it will outwear floor coverings 150% as thick and the colors cannot be worn off because they are IN the Vinylite clear through to the Permo-Seal back.

■ **Priced for popular budgets.** Though luxurious in appearance and performance, FLOR-EVER is not a premium floor. Its installed cost is comparable to that of most popular high quality floor coverings. Investigate.

send for your sample set

If you are a practicing architect or designer, an active builder, or otherwise concerned with specifying floor coverings, we shall gladly have delivered to you full descriptive and technical material plus a complete set of samples, *without obligating you in any way*—and we know this material will help you do your job more efficiently and profitably. Mail the coupon.

Manufactured by one of America's leading floor covering manufacturers:
DELAWARE FLOOR PRODUCTS, INC., Established 1930
Plants: Wilmington, Del. Manufacturers of FLOR-EVER, Kolorflor, Duralin.



DELAWARE FLOOR PRODUCTS, INC. MBI-51
Architects Service Dept.

295 5th Ave., New York 16, N. Y.

Without obligation, please have your representative deliver a set of FLOR-EVER color samples, usable as a guide in specifying or ordering.

Name _____

Company _____

Address _____

City _____ State _____



TRANE

ANNOUNCING THE **CenTraVac**

A Great Trane Development in Centrifugal Refrigeration

Trane's Revolutionary New Water Chilling Unit!

Now, a Centrifugal to furnish chilled water for installations as low as 45 tons! A new kind of Centrifugal—with hermetically sealed direct drive, with automatic power reduction that parallels capacity reduction over wide operating ranges, with stable operation from 100% down to 10% of rated capacity.

The new compact CenTraVac operates quietly without vibration, can be located conveniently in buildings without special foundations. Impellers are mounted directly on the shaft of the water cooled, hermetically enclosed motor within the machine. No gear boxes or shaft seals, only two main bearings in the entire unit! Improved lubrication designed for long, trouble-free life.

One installation, one wiring job, one set of controls . . . the new Trane CenTraVac is the only centrifugal unit designed to supply chilled water economically for the smaller jobs as well as the big ones! Five models to choose from between 45- and 190-tons.

Not one, but 3 New Trane Air Conditioning Products!

With the announcement of the products shown on these pages . . . the new CenTraVac, the new Reciprocating Compressor, the new Self-Contained Air Conditioner . . . it's more logical, more advantageous than ever to build entire systems around a selection of Trane components.

See these and other new products on display in the giant Trane booth at the 10th International Air Conditioning Exposition in Philadelphia, January 22-26. Find out for yourself how the complete Trane line can make your job easier.

Now, with the addition of these great new products to the extensive Trane line, you may turn to one completely reliable source to provide you with:

1. Undivided responsibility for performance of your entire system.
2. Essential parts designed, manufactured, and tested together for use together.
3. Selection from one set of catalogs, using uniform ratings.
4. Convenience: Basic products are ordered together and shipped together.

Rear view of new centrifugal compressor showing clean cut design.

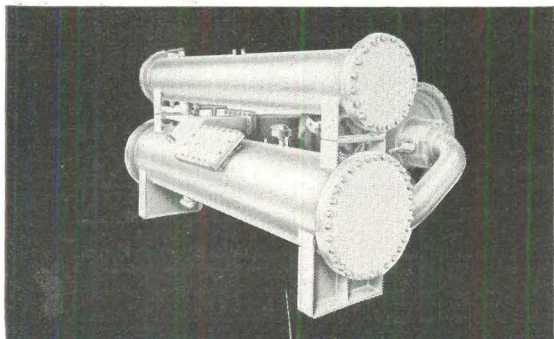

Radial blade cast impeller for high efficiency.

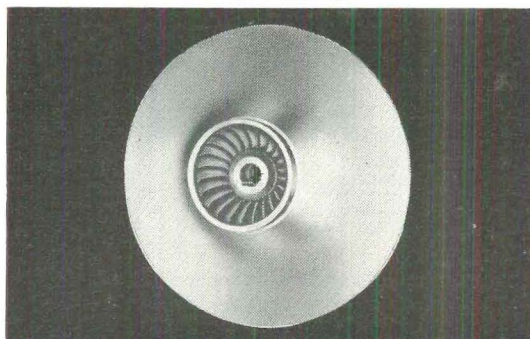

Variable inlet vane assembly provides the ultimate in capacity control.

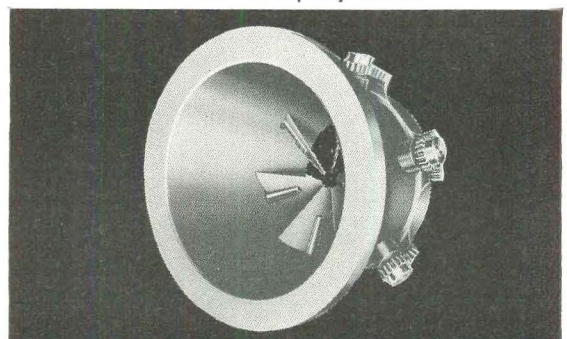

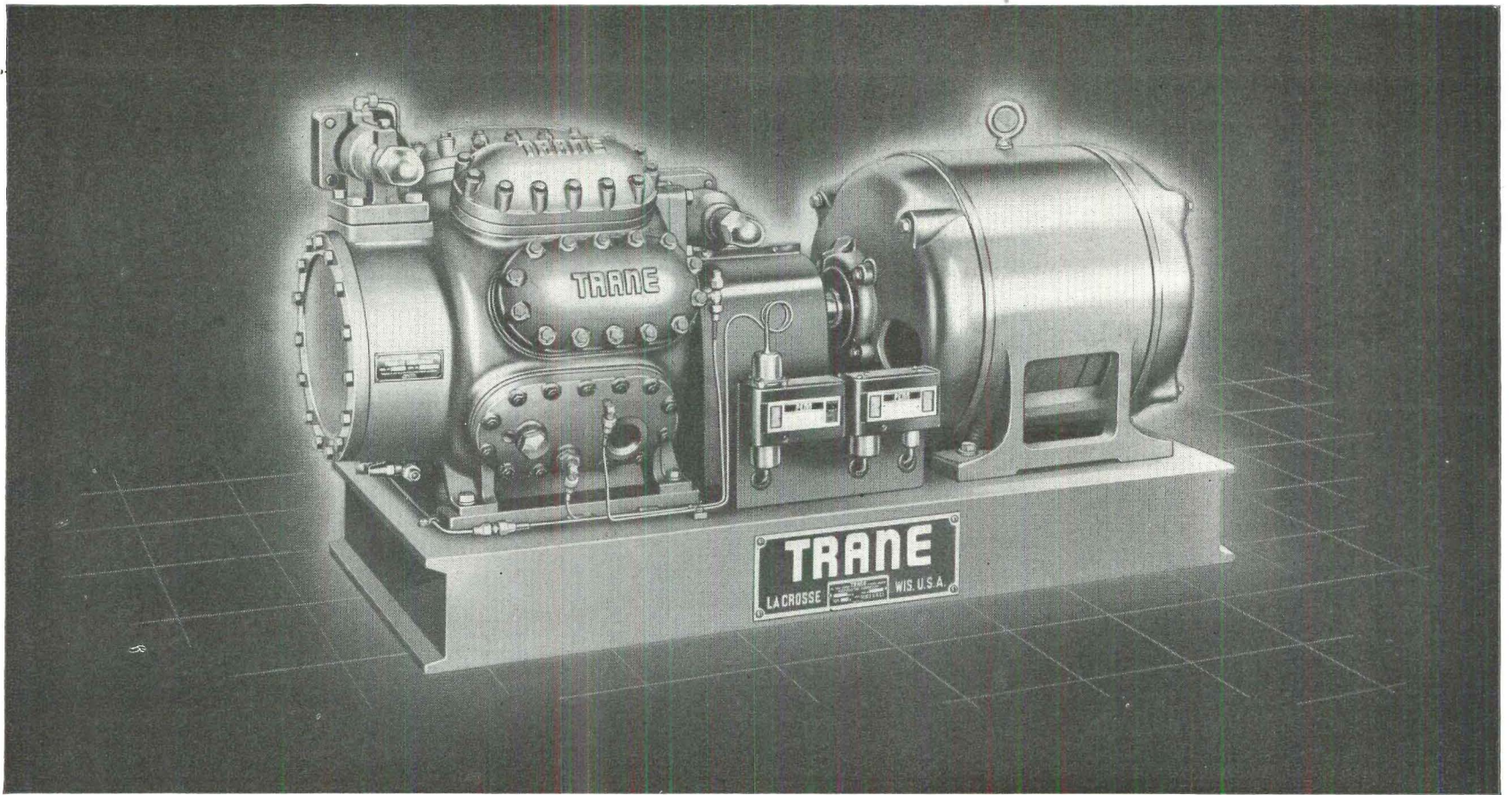

and also introducing a brand-new, all-new
TRANE RECIPROCATING COMPRESSOR

More Cooling Per Kilowatt . . . Less HP Per Ton!

Higher efficiency . . . smoother running . . . longer lasting . . . that's the brand new, all-new Trane Reciprocating Compressor!

This clean-cut and compact new Trane compressor unit features a completely internal, multi-step capacity control system with power consumption automatically reduced under reduced cooling demands. New Trane method makes possible big power savings with favorable tonnage-to-horsepower efficiency even under greatly reduced loads.

Constant-speed, direct-drive construction and carefully counterbalanced lightweight rotating parts within the machine account for its smooth running, vibration-free operating characteristics. A penny will stand on its edge on the body of the compressor throughout all phases of operation.

New type, long lasting valves were developed by Trane engineers for extra years of trouble-free performance. New forced-feed oil system employs exclusive Trane method, is designed to supply all moving parts with a positive flow of clean, grit-free,

Cutaway front and side view 8-cylinder Trane Reciprocating Compressor, showing essential parts in a minimum space.

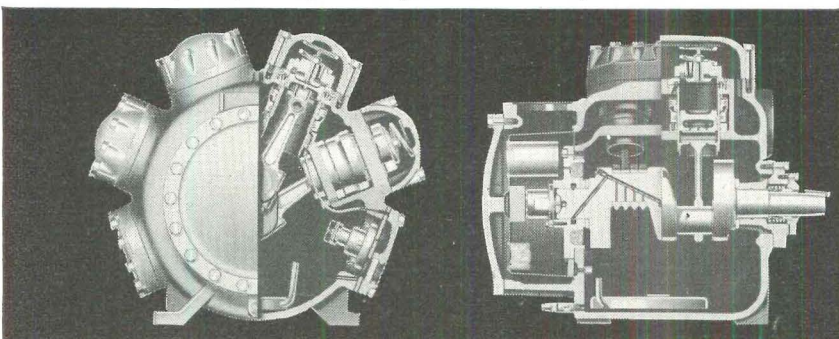

refrigerant-free lubrication. Actual laboratory tests show that Trane valves last as much as 900% longer; other critical parts still within original manufacturing tolerances after constant operation equivalent to at least 7 seasons of normal compressor service!

Completely Trane-designed and Trane-built, this new reciprocating compressor line consists of six models, each featuring the same exclusive advantages . . . each engineered to provide a new high in dependable, low-cost refrigeration for air conditioning applications within the 10- to 50-ton range.

Call your Trane representative for full performance data and capacity range of these new Trane products.

THE TRANE COMPANY . . . LA CROSSE, WIS.
 EASTERN MANUFACTURING DIVISION, SCRANTON, PA.

Manufacturing Engineers of Heating, Ventilating and Air Conditioning Equipment—Unit Heaters, Convactor-radiators, Heating and Cooling Coils, Fans, Compressors, Air Conditioners, Unit Ventilators, Special Heat Exchange Equipment, Steam and Hot Water Heating Specialties . . .
 . . . IN CANADA, TRANE COMPANY OF CANADA, LTD., TORONTO

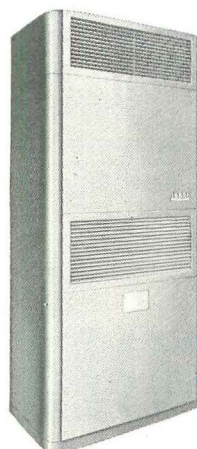

◀ **NEW, TOO! THE S-C UNIT**

Here's another new product of Trane engineering, a neater, more compact Self-Contained Air Conditioner! A sturdier machine that occupies a minimum of floor space and is available in sizes of 3-ton capacity and up . . . all giving extra quality at competitive prices.

Units feature an accessible hermetic compressor, the famous Trane Cooling Coil, thorough vibration elimination, panels insulated with fireproof fiber glass, two-directional outlet grills, quiet operation. Cam locked front panels are easily removed for easy servicing and maintenance. Optional discharge chamber with heating coil, if desired.

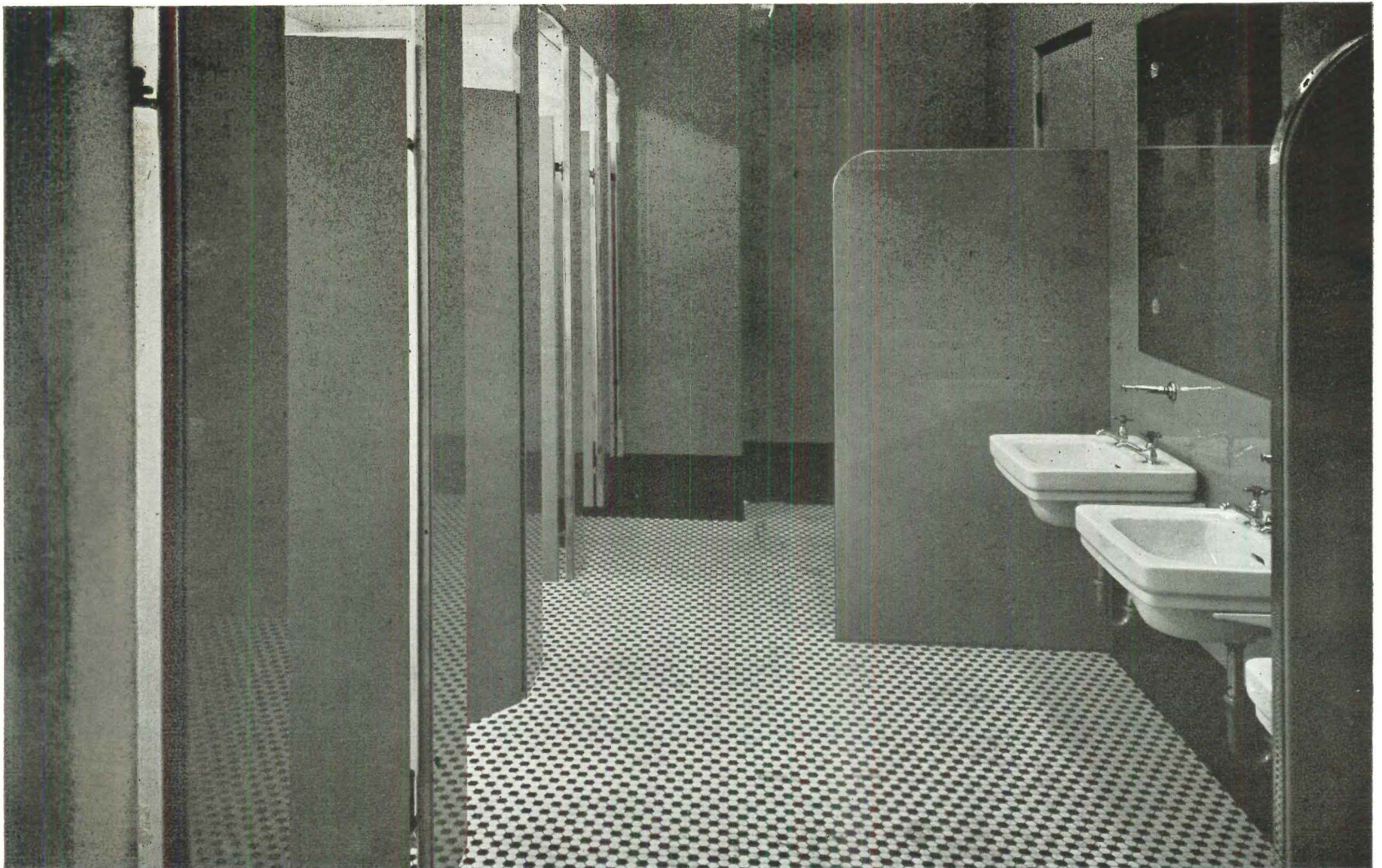

Crowley-Milner Department Store, Detroit.



CLEAN!...and it says so!

No one can miss the clean look of *Vitrolite** glass paneling. Building patrons can see it in a glance.

Owners find they can keep these modern-looking walls sparkling clean with remarkably little maintenance. Glass is so smooth, so impervious, that it discourages scribbling and "art work". Glass cleans easily, quickly and inexpensively.

Of course, cleanliness is not the whole story. There's deep-toned luster in walls of *Vitrolite*—in smart colors that not only have a distinctive look, but *keep* it. Fading, crazing and warping just don't happen. *Vitrolite* never needs refinishing. The swish of a damp cloth and it looks new. *Vitrolite* doesn't absorb odors, germs or moisture. It's a natural choice for rooms that should make a good impression... and for rooms that must face up to a careless public—washrooms, lobbies, corridors, cafeterias.

Vitrolite's colors are correlated to blend or contrast for a wide variety of decorative effects. For complete data, see your L·O·F Glass Distributor, or write for our architect's file book on *Vitrolite*. *©

10 Correlated Colors Suggest Distinctive Decorative Ideas

- Sky Blue
- Light Gray
- Jade
- Peach
- Red
- Cadet Blue
- Dark Gray
- Cactus Green
- Alamo Tan
- Mahogany

Plus Black and White



VITROLITE

MADE BY
LIBBEY·OWENS·FORD GLASS COMPANY
4711 Nicholas Building, Toledo 3, Ohio

Two Types of Marbleization

Now Available

in Armstrong's Asphalt Tile

Architects now have the choice of two distinctive marble-type grainings in Armstrong's Standard Asphalt Tile. The regular sharply defined marbleization with contrasting colors—and a new decorator-type pattern in soft, muted grainings of monochromatic colors.

This new series in Armstrong's Standard Asphalt Tile is known as "Designer's Palette," Series E. Each tile color is obtained from close value tones of the same color. The beauty of the monochromatic coloring is further enhanced by Armstrong's exclusive non-directional graining. The colors are in harmony with one another and can be used in combination with the A, B, C, and D colors for pleasing effects. They offer the architect the same eleven monochromatic colors that proved so popular in Armstrong's Arlon Tile which has been withdrawn because of raw material restrictions.

In the B, C, and D Series, the sharply defined non-directional graining which characterizes Armstrong's Asphalt Tile gives them unusual beauty. They are widely used in all types of interiors.

Designer's Palette, Series E, colors in Armstrong's Asphalt Tile offer a new concept in low-cost floor beauty for residences, offices, stores, schools, hospitals, and all types of basementless buildings. The colors are not affected by alkaline moisture and are highly resistant to the harmful action of harsh alkaline cleaning solutions.

Designer's Palette, Series E, colors are available in 9" x 9" tiles in 1/8" and 3/16" gauge. Full color descriptions may be seen in the 1951 edition of Sweet's Architectural Files or Armstrong's Pattern Book.

For samples, installation specifications, and other information on Designer's Palette Series, as well as any of Armstrong's Resilient Floorings, architects are invited to contact the nearest Armstrong District Office or write directly to the Armstrong Cork Company, Floor Division, 2601 State Street, Lancaster, Pennsylvania.

The soft, muted graining of the Designer's Palette, Series E, monochromatic colors make this flooring an ideal choice for areas where a rich and highly decorative yet informal appearance is desired.



ARMSTRONG'S RESILIENT FLOORS

LINOLEUM • LINOTILE® • ASPHALT TILE



RUBBER TILE • CORK TILE • LINOLEUM TILE

...AND FOR HELP
WITH THE
HEATING CONTROL,
WE'LL TALK TO
HONEYWELL!

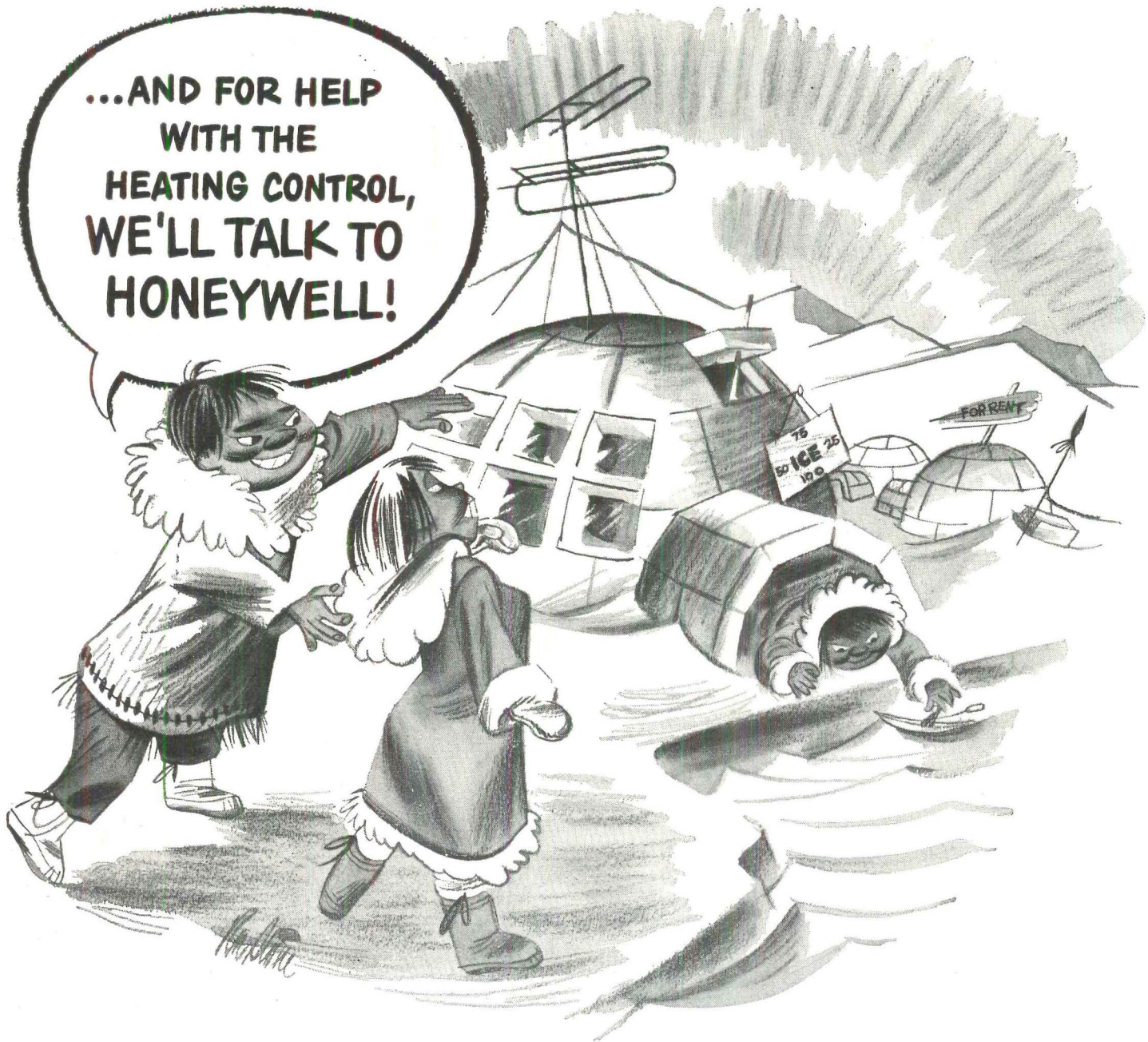

We doubt that you've worked on many igloos lately. We haven't helped heat any, either.

But we *can* help architects and their heating engineers provide the proper thermal environment for any client—anywhere—in any kind of structure.

We have a lot of literature on the automatic control of all phases of heating, ventilating and air conditioning. Information you should have in your files. And we have a lot of very well informed control

engineers—in our 87 different offices—who have a lot *more* information right at their finger-tips.

We sincerely believe we can help you on any project that poses problems of control of any kind—for *control* is Honeywell's business.

So, why not *talk to Honeywell?* Why not *write to Honeywell* for complete information on the equipment discussed in the column across the page? And why not do it *now?*

MINNEAPOLIS
Honeywell

First in Controls

LETTERS

completely unrelated buildings designed by architects who not only failed to relate their works to their neighbors, but have generally tried to out-do them. The result is architectural chaos, as some of the visiting architects may see more clearly than we.

The Secretariat, as a piece of architectural "sculpture" is, above all, *simple*; it is beautifully proportioned, but hardly a great work of art in itself. The art of the UN building is achieved in the magnificent composition of the Secretariat and the General Assembly, one with the other and both together with the land, the highway and the river. Here is architecture in a new and broader sense, suggested at Rockefeller Center, but developed only now. Here is a design complete in itself, but which because of its simplicity, will always complement and thereby enhance adjacent constructions.

The UN buildings recognize a new field in architecture: there has always been the detail, the room layout, the floor plan, the plot plan; now the *area* plan.

NATHANIEL W. SAMPLE, III, *Architect*
Madison, Wis.

BUILDING:

... And the "architects" leave us that abortion of architecture, the UN building.

"International Style" indeed—my wish is that this building serve as the monumental "tombstone" to all "stylized" architecture and that we will now go on to the architecture of a true democracy.

Architecture that speaks truth with nature is the architecture of peace.

ARTHUR A. SERCHIA
Los Angeles, Calif.

BUILDING:

Your November issue containing the stimulating article on the UN Secretariat has moved me to commendation.

The inclusive and finely presented review of the UN buildings was made especially interesting by being joined to a debate on its merits and demerits by some of our leading architects.

Two matters come to mind in perusing this article: First, the very wide and divergent opinions held by the debate participants on all issues. Could this divergence be more elaborately expounded to the extent of disclosing the apparently widely divided philosophical bases it rests upon? And, second, the inclusion of some debaters who are in other professions (such as philosophers) would have broadened the field of commentary and the range of ideas and response. It is, perhaps, *most* important for us to know what reaction these buildings will have on the "man in the street."

ROBERT C. GAEDE, *Architect*
Cleveland, Ohio
(Continued on page 52)

They won't help you heat igloos, but they will help you on many other problems of control—so write us now for these



Facts you need—FREE!

Just check space opposite equipment you're interested in, fill in your name and address and mail this column to us. We'll get your facts to you promptly.

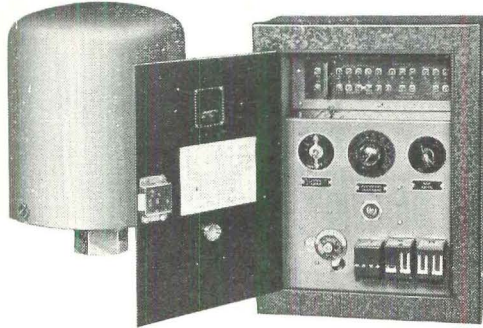

Weatherstat systems tend to eliminate underheating and overheating. Mounted outside, these sensitive instruments compensate for such variable factors as sun, wind, air temperature, etc. Thus, they meter heat in direct proportion to need—provide uniform comfort at lowest possible fuel cost. Available in on-off, or modulating systems. Check here for 16-page booklet.

Pin-point temperature control in pneumatic systems is now possible—thanks to this new Automatic-Reset Pneumatic Relay. Virtually eliminates offset, hunting and cycling in pneumatic systems. In comfort applications, it guarantees maintenance of temperatures at thermostat setting, even in severest or mildest weather. Check here for free folder.

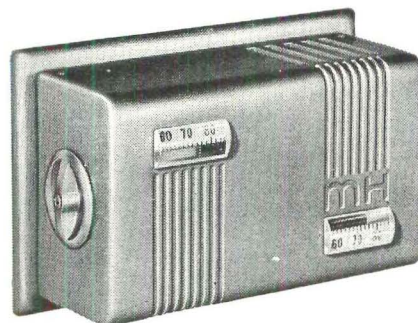
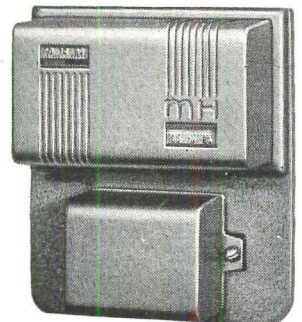

Hospital Thermostat with "Nite-Glowing Dials"—first thermostat ever designed specifically for hospital needs. Luminous dials glow in the dark and are easy to read without lights. No electrical connections required. Magnified indicators. New speed-set control knob, camouflaged against tampering. Simplified design eliminates frequent adjustment. Check here for 12-page booklet on hospital temperature control.

MINNEAPOLIS-HONEYWELL REGULATOR CO.
Minneapolis 8, Minnesota, Dept. MB-1-07

Name _____

Firm Name _____

Address _____

City _____ Zone _____ State _____

extra whiteness

for mass or contrast in architecture



"The little red schoolhouse" of song and story is, today, quite apt to be an imposing structure of gleaming white. In schools—as in hospitals, apartment, office, public and industrial buildings—whiteness gives smartness to current designs. Trinity White—the *whitest* white cement is a true portland cement and meets Federal and ASTM Specifications. Use it in architectural concrete units and in a variety of other forms including terrazzo, stucco and cement paint.

as white  as snow

plain or waterproofed

TRINITY WHITE portland cement

Trinity Division, General Portland Cement Co., 111 W. Monroe St., Chicago; Republic Bank Bldg., Dallas;
816 W. 5th St., Los Angeles; 305 Morgan St., Tampa; Volunteer Building, Chattanooga.



In Electric Exhaust Ventilators **THIS ISN'T ALL** →

...The Blade's the thing!

Blo-Fan*
HAS THIS BLADE EXCLUSIVELY!

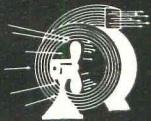

Efficiency

The patented Blo-Fan blade combines the volume of a breeze fan with the power of a blower to move air quickly, quietly and efficiently. No other electric exhaust ventilator has this blade!



Adjustability

Only Blo-Fan Model 210 has this NINE-position control switch that makes it as easy to control the rate of ventilation as it is to regulate the thermostat on a kitchen range.

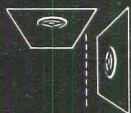

Adaptability

Blo-Fan installs over the point of air pollution—in the ceiling or any wall (inside or outside). Requires only 3 1/2 inches behind plaster; uses standard 3/4" x 10" furnace duct.

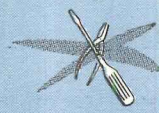

Simplicity

Blo-Fan is easier to clean—no tools are ever required—NOT EVEN A SCREW DRIVER. All you do is unscrew the large center cap and remove the grille and motor assembly.



Experience

For over 25 years Pryne and Company has made home owners happy by manufacturing superior electric ventilators especially designed for home use in the kitchen, bath, game room and laundry.

Blo-Fan AMERICA'S MOST IMITATED HOME VENTILATOR
Stocked by more than 650 wholesalers in over 350 cities
Manufacturers of Pry-Lites... the original recessed lighting fixture with snap-on fronts
PRYNE & CO., INC. BOX A-1, POMONA, CALIF.
Warehouses: Los Angeles, San Francisco, Chicago, Atlanta
Eastern Factory: Newark, New Jersey

*Trade Mark Reg.

Everything



PASSERS-BY stop, look and enter when they see an open-vision front like this women's wear store at Medford, Massachusetts. Here Pittsburgh Polished Plate Glass, Herculite Doors and Pittco Store Front Metal have been enlisted to help create the kind of front that modern retailers want to spur the movement of their merchandise. Pittsburgh has a complete line of quality products to assist in achieving distinctive, attention-compelling, sales-winning store fronts. Architects: Herman L. Feer and William E. Nast, Boston, Mass.

PITTCO De Luxe Store Front Metal includes a complete line of bars and sashes for use with Twindow—Pittsburgh's window with built-in insulation. These members are extruded and assure rugged strength, clear, sharp profiles and a smooth finish, rich in tone and gloss. They can be used with all Pittco De Luxe standard frame mouldings, thus offering latitude of design for top quality store front installations requiring insulated windows. The most commonly used of the Pittco members for Twindow installations—two sashes and a division bar—are themselves insulated, thus reducing heat loss through them.

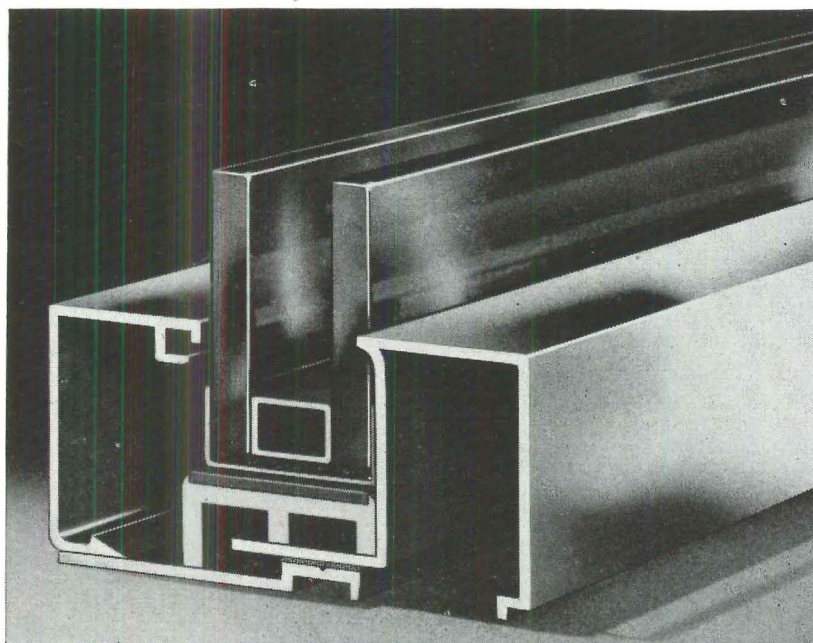

for the modern store
under one reliable name



FACTORY-ASSEMBLED, completely "packaged" Pittsburgh Doorways are precision-fabricated to cut costs on the job. No time-consuming calculations, laborious assembly work or irksome details of setting and fitting are involved. The handsome, extra-heavy extruded aluminum frame, reinforced with steel, is simply bolted into the building opening. Then the Herculite Doors, for whose rugged strength the frame has been especially engineered, are hung and the installation is complete. Inset shows the Pittco Checking Floor Hinge—a compact unit, only $6\frac{1}{4}'' \times 6\frac{1}{4}''$, and a marvel of modern engineering. This hinge is permanently located in its own reinforced box in all Pittsburgh Doorways. It has positive door-speed control, separate checking control, built-in hold-open feature. It is sealed in oil for life.

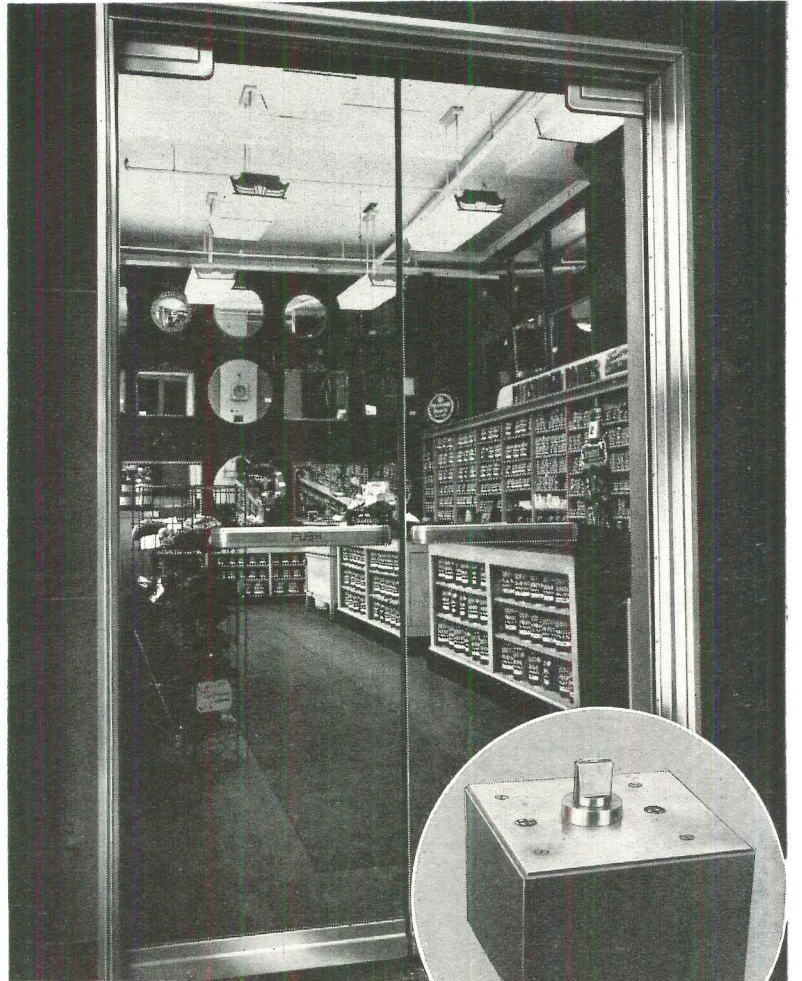

CARRARA Structural Glass is a finely-machined product, rich, flawless and brilliant of surface. It has a closely-knit structure. Its joints are true and even, so there is no lippage. And there is no warpage. Carrara will not check, craze, fade, stain or discolor with age. It is impervious to weather, water, acids, chemicals, grease and pencil marks. It is equally suitable for a front of classic simplicity or for one marked by an unusual design. It is ideal also for decorating interiors and for the walls, stiles and partitions of washrooms and lavatories. Carrara Glass is available in ten attractive colors and in a wide range of thicknesses.

Design it better with **Pittsburgh Glass**



Your Sweet's Catalog File contains a complete listing and descriptions of Pittsburgh Plate Glass Company products.

PAINTS · GLASS · CHEMICALS · BRUSHES · PLASTICS

PITTSBURGH PLATE GLASS COMPANY

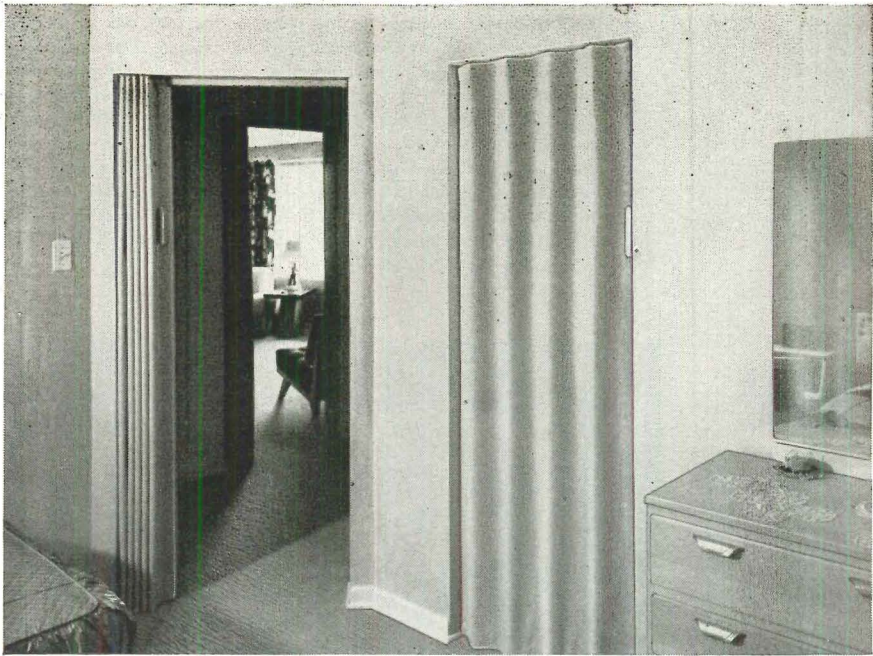

W. A. CARSON, Builder, says

"MODERNFOLD" DOORS

cost less per opening — create more interest

Fifteen houses already completed and sold! Starts made on thirty more! "Modernfold" doors used throughout in all openings—by Carson Construction Company, Helena, Montana.

"And," says W. A. Carson, "the 'Modernfold' doors caused more comment than any other feature of our house. We selected 'Modernfold' doors because we felt our customers would appreciate the space-saving features as well as the decorative value."

Mr. Carson further reveals that cost of "Modernfold" doors per opening was less than using conventional wood doors. No wonder he plans on *always using "Modernfold" doors wherever possible!*

Cost saving! Space saving! Sales appeal! Yes, that's why builders and architects have insisted on "Modernfold" doors since 1936... for both residential and commercial installations. Get the full *profit* story today. Look up our installing distributor under "doors" in your classified phone book... or mail coupon.

See our exhibit at the Home Builders Show, Booths 89 and 90

NEW CASTLE PRODUCTS, New Castle, Indiana
In Canada: Modernfold Door Company of Canada, Limited, Montreal

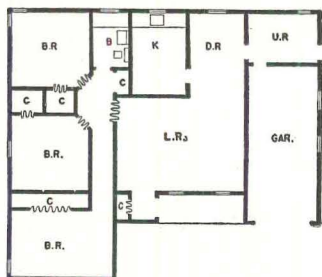

Rooms are actually bigger in this house because "Modernfold" doors' accordion-like action saves 20% space which ordinary doors would have wasted.

Architects and builders specify "Modernfold" doors for offices, stores and institutions... to assure more use from space by dividing it for greater convenience and privacy.



Sold and Serviced Nationally

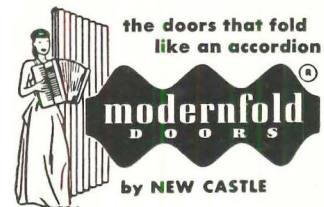

COPYRIGHTED NEWCASTLE PRODUCTS, 1951

New Castle Products
P. O. Box 806
New Castle, Indiana
Gentlemen:
Please send me full details on "Modernfold" doors.
Name.....
Address.....
City.....County.....State.....

LETTERS

CLIENTS' LAMENT

BUILDING:

For the sake of architects and their clients would you please start educating architects on the psychology of gaining the confidence of people, especially by virtue of ability.

There is a big field for psychology in the business of building. . . . The psychology of color, effect of sound, blending of social and artistic ideas of homeowners by an objective personality, psychology of child growth and development, psychology of gaining the client's confidence . . . Architects' education should include "How to design a house so the wife can get the work done and still be an individual and have sparkle and humor and good meals. . . ."

MARJORIE NEWHALL
Santa Cruz, Calif.

BUILDING:

Structural Hips

Since kitchens always art too small,
I view apartments with appall.
Such cubicles cannot eclipse
The fact that lots of gals have hips.
Yet, "in the groove," twixt stove and shelf
I bake and broil and fry—myself.
(And, irate from the fiery glow,
I mutter words I shouldn't know!)
The meal—and I, done to a turn,
My vengeance does a slow burn,
And with my disposition wrecked,
I yearn to fry the architect!

LYDIA LICHTY
Lichty Engineering Co.
Birmingham, Ala.

BUILDING:

We are writing neither as architects nor as builders, but as those poor suckers, the clients. One year ago we went to a team of architects who have won innumerable prizes and honorable mentions, many of whose houses we liked. They were about our age, and therefore, we hoped, able to speak our language.

Without going into any of the rather painful details, we finally received plans which were absolutely beyond our means to execute. . . . Not only did they know what we were prepared to spend on the house, but they had been asked whether they could give us a reasonable facsimile of what we wanted for that price. They were told that if they couldn't, we would pay a quittance fee on the time already spent. The designed house was handsome, but the lowest estimate from any builder of reputation in the area ran 40 per cent higher than the amount we could spend. Since we had set a figure of \$20,000, an additional \$8,000 seemed somewhat too much. And that, of course, did not allow for the extras which will creep in.

We have filed these handsome plans at the very bottom of a bureau drawer and have

(Continued on page 56)

Duty-Designed

BY **TIMKEN** *Silent Automatic*

To Help You Build Better Homes
Within Your Construction Budget!

KITCHEN-TYPE OIL BOILERS
—the most revolutionary development in modern small-home heating—automatically heat the home, also supply ample domestic hot water.

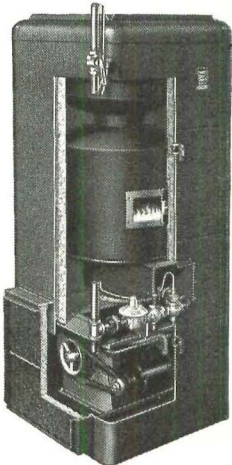
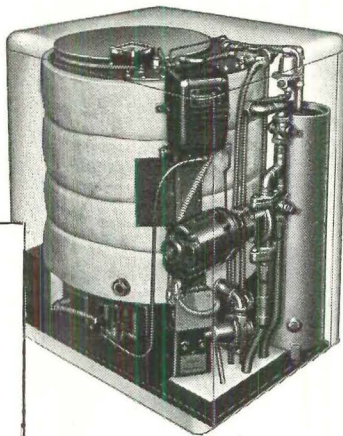
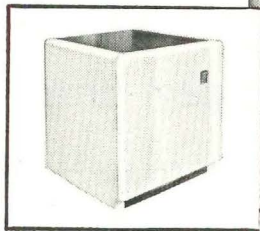

"DUTY-DESIGNED" OIL HI-BOILERS are built to give small homes all the comforts of modern oil heat—plus automatic domestic hot water. Unusually quiet and compact.

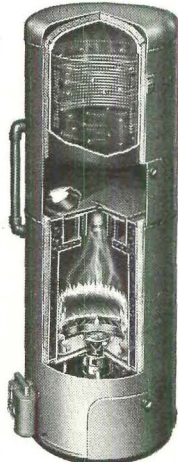

COMPACT OIL AND GAS HI-FURNACES, specifically designed for small homes, bring to every owner the full benefits of winter air conditioning without a cost premium.

More and more alert architects and builders are gaining important design advantages—and making major construction savings, too—thanks to the matchless heating experience of Timken Silent Automatic. For some of the results of 25 years devoted to the development of fine heating equipment at realistic prices, look below.

COMPACT DESIGN—Close attention to every detail of design engineering has held required floor area to a minimum. All the finest modern features are combined in a complete line of ultra-compact units ideal for small homes.

QUIET OPERATION—The truly exceptional quietness of the famous Wall-Flame Burner—a sound level so low it can scarcely be heard—has proved its value in hundreds of thousands of installations, especially next to living quarters.

EFFICIENT PERFORMANCE—For many years Timken Silent Automatic oil-fired equipment has produced fuel oil savings of 25% or more. Now modern design has also made Timken Silent Automatic gas-fired equipment outstanding for economy in its field.

COMPETITIVE PRICE—Timken Silent Automatic heating equipment is priced to compete with other makes of comparable quality—or even less than comparable quality. Best proof is its widespread installation in the most strictly budgeted housing projects.

FACTORY ASSEMBLY—Every feasible assembly operation, including all essential wiring and plumbing, is completed before each Timken Silent Automatic unit is shipped from the factory. Installation is greatly simplified and speeded by truly *utilized* construction.

Write today for full details and performance data!

93 MODELS OF FINE
HEATING EQUIPMENT
FOR OIL, GAS AND COAL



PLANTS AT: DETROIT AND JACKSON, MICH. • OSHKOSH, WIS. • UTICA, N. Y. • ASHTABULA AND KENTON, OHIO • NEW CASTLE, PA.

why take 5.....

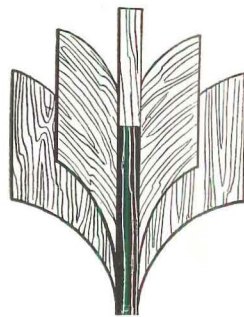

when you can get 7.....

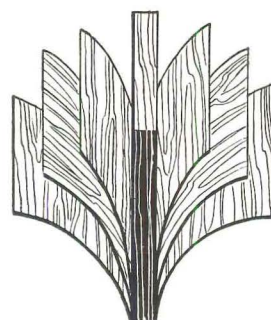

Roddiscraft Housemart Doors feature 7-ply construction

Seven ply construction gives Roddiscraft Housemart Hollow Core Doors greater strength, greater resistance to distortion and prevents core pattern showing through face veneers after finish has been applied.

Three ply face panels are bonded under heat and pressure with water-resistant Urea Resin glue. Face panels are then bonded in electronic presses to both sides of the core assembly to form a rigid 7-ply unit.

The Roddiscraft Housemart Door is generously made throughout. Extra wide top and bottom rails allow for trimming—ample edge strips provide a firm foundation for hardware—lock blocks both sides with inner edge 5 inches from door's outer edge.

Designed and priced for residences and multiple dwelling units, the Roddiscraft Housemart Door has proved itself a beauty with brawn in all types of installations.

See *SWEET'S ARCHITECTURAL FILE*, No. $\frac{16c}{R0}$ for the complete Roddiscraft Door line.

NATIONWIDE Roddiscraft WAREHOUSE SERVICE

Cambridge, Mass. • Charlotte, N. C. • Chicago, Ill. • Cincinnati, Ohio • Dallas, Texas • Detroit, Michigan • Houston, Texas • Kansas City, Kan. • New Hyde Park, L. I., N. Y. • Los Angeles, Calif. • Louisville, Ky. • Marshfield, Wis. • Milwaukee, Wis. • New York, N. Y. • Port Newark, N. J. • Philadelphia, Pa. • St. Louis, Mo. • San Antonio, Texas • San Francisco, Calif.

Roddiscraft

RODDIS PLYWOOD CORPORATION
MARSHFIELD, WISCONSIN

*There is
no substitute
for experience*



ACCREDITED SOURCES indicate that only about 2% of our Manufacturing Corporations have been in business continuously for 65 years. Fitzgibbons is proud to be among those select few.

The experience gained by our sixty-five years in building quality steel boilers is your assurance of top design, top construction, top performance.

The story of how Fitzgibbons has maintained its position and enhanced its reputation during sixty-five years of changing conditions and fuels, is of interest to all boiler users. We invite you to read this story in a new booklet, entitled "Straight Ahead Since 1886." A complimentary copy will be mailed you on request.

Visit our booth at the A. S. H. & V. E. Show, January 22-26, Philadelphia, Pa.



Fitzgibbons Boiler Company, Inc.

GENERAL OFFICES: 101 PARK AVENUE, NEW YORK 17, N. Y.

BRANCHES AND REPRESENTATIVES IN PRINCIPAL CITIES

Manufactured at OSWEGO, N. Y.





**WHEN YOU ARE READY TO SELECT
SPACE-SAVING DOORS...**
Check these important features



THAT "FINISHED LOOK"—FOLDOOR comes in a wide choice of beautiful, colored, highly durable plastic-coated fabrics to harmonize with any color scheme. Topped with an attractive cornice, FOLDOOR installations have that *finished look*.



"EASY GLIDE" OPERATION—Built with a sturdy frame of rust-resistant steel, FOLDOOR travels on a rugged, single piece, two-rail steel track. The double-truck trolley, with large-diameter wheels, insures smooth, *easy-glide* operation.



"DOOR-KNOB HEIGHT" HARDWARE—Handles at normal, *door-knob height* is a FOLDOOR feature especially desirable in homes with small children. FOLDOOR'S simple yet positive latching mechanism is easily operated with one hand. No fussing, no fumbling with FOLDOOR.



"WALL-FIT" THICKNESS—FOLDOOR occupies the least amount of "stack" space of any extensible door. When pushed back onto itself, FOLDOOR'S maximum thickness is only 5½ inches. This means FOLDOOR fits inside the measurements of most walls—does not stick out into the room.

You get them all with new, improved

HOLCOMB & HOKE

FOLDOOR

HOLCOMB & HOKE MFG. CO., INC. • INDIANAPOLIS, INDIANA

Profitable Installing Distributorships Still Open

LETTERS

searched until we found a suitable plan in *House Beautiful*. That plan has been altered in close collaboration with our builder and our heating man, also with the engineers from Chase Copper & Brass and other very courteous corporation representatives, and we have succeeded in building a house which answers our needs. . . Even in this period of skyrocketing costs, the house will be completed for approximately \$21,000, starting from a \$19,000 estimate and including all the extras which have crept in as expected.

Our questions: First, what good does it do an architect to design a house which the client has to file in the waste basket? Second, doesn't the architect find it rather expensive to collect that one fee when the client is making sure his experience is passably well known? Third, must the architect work his own ideas out on the client, rather than the client's out in an acceptable form? Fourth, may the client have very little to say about the house in which he intends to live? Fifth, who is the employer—the client or the architect?

We have our contemporary house, thanks to an architect who has never heard of us, and to the builder and other technical men who have been patient and cooperative. We will hesitate a long time before again risking 10 per cent or better of our investment on the services of an architect.

ELIZABETH AND HARRISON KIMBALL
Peterborough, N. H.

ENDLESS HOUSE'S BEGINNING

BUILDING:

Regarding Frederic Kiesler's Endless House (BUILDING, Nov. '50) and its obvious fetal, in fact, embryonic origin: the origin, to use a cliché, is the beginning. Why end with it?

What is "more economical with regard to materials, fuel consumption . . . management, maintenance" than the embryonic animal?

Accepting this hypothesis, why did any of us bother to progress beyond the third or fourth pre-natal month? Unless, perhaps, BUILDING and Mr. Kiesler are having their little Freudian witticism.

GURNEY CONYERS
Phoenix, Ariz.

• Building was.—Ed.

A LENDER ON REGULATION X

BUILDING:

I am somewhat disturbed to note that BUILDING seems to be lending support to those who would liberalize, if not remove, Regulation X. Instead of liberalizing Regulation X, it seems to me quite obvious that this restraint on mortgage credit should have been instituted earlier in the year. If it had been, both buyers of residences and lenders on their security would have benefitted.

Is it not obvious that the Government made

(Continued on page 62)

**You get better
masonry walls
with
Pittsburgh
Steeltex**

When you specify *Pittsburgh Steeltex* for masonry veneer, you get a better wall for two very basic reasons. First, the veneer and frame are more completely bonded together, thus providing greater mutual assistance against later settling and distortion. Second, you'll never have the trouble of wet sheathing. For further good reasons to specify *Steeltex* see our catalog in Sweet's or write for your copy of our catalog D. S. 132, Dept. AF, Pittsburgh Steel Products Company, Grant Bldg., Pittsburgh 30, Pa.

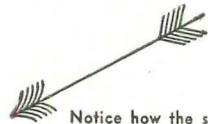
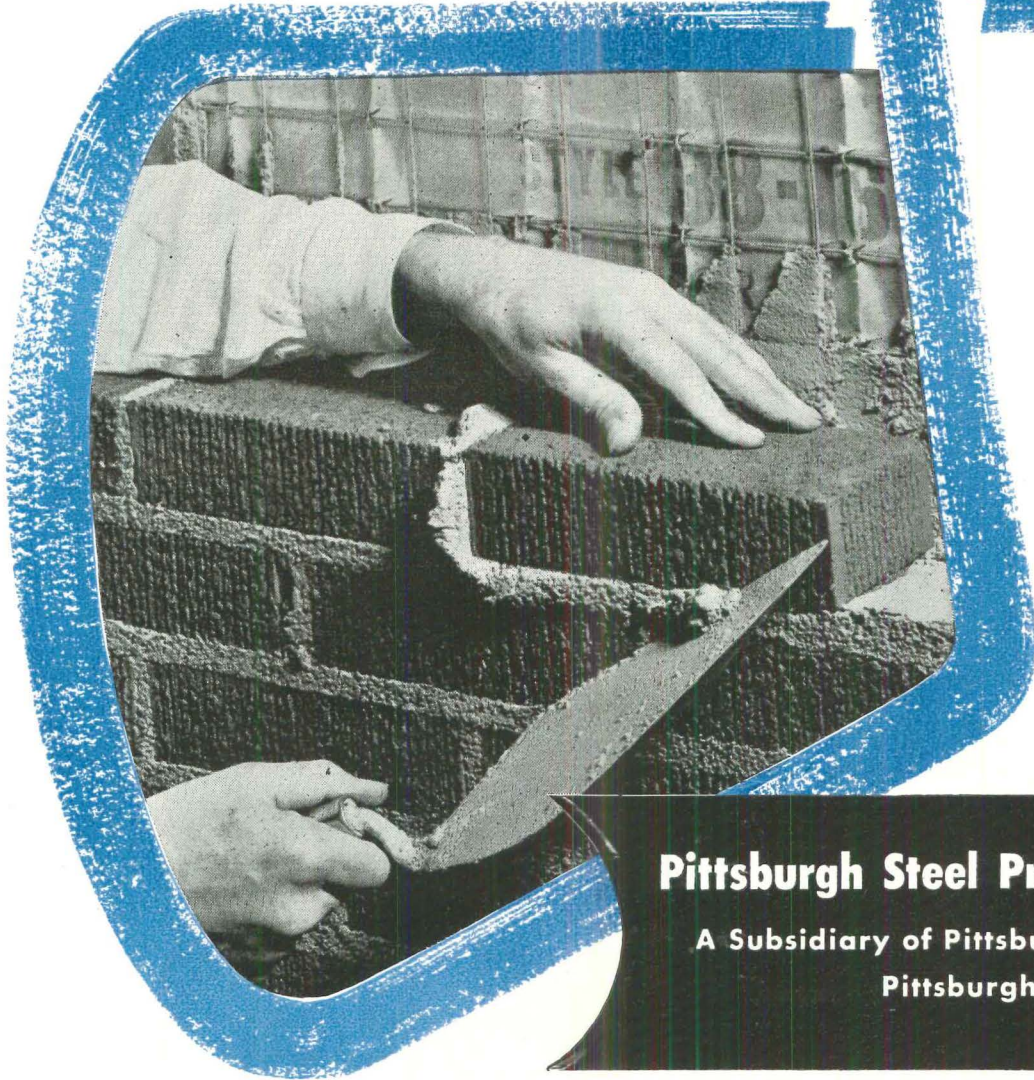

Notice how the strong, welded, galvanized steel mesh bites into the continuous mortar bond.

Pittsburgh Steel Products Company

A Subsidiary of Pittsburgh Steel Company
Pittsburgh 30, Pa.



Here's Complete Information on the

New NUMBERING SYSTEM

FOR A305 REINFORCING BARS

A new method of identifying reinforcing bars for size has recently been adopted by the steel industry. In this new system, bars are designated by numbers from 2 to 11. However, the new bars will have the same cross-sectional area as the old bars, so design tables, etc., will not need to be changed. The bar chart below explains the new designations.

CONCRETE REINFORCING STEEL INSTITUTE
38 SOUTH DEARBORN STREET, CHICAGO 3, ILLINOIS

STANDARD A305 REINFORCING BARS

BAR SIZES		WEIGHT POUNDS PER FOOT	NOMINAL DIMENSIONS — ROUND SECTIONS		
OLD (INCHES)	NEW (NUMBERS)		DIAMETER INCHES	CROSS SECTIONAL AREA - SQ. INCHES	PERIMETER INCHES
1/4	2	.167	.250	.05	.786
3/8	3	.376	.375	.11	1.178
1/2	4	.668	.500	.20	1.571
5/8	5	1.043	.625	.31	1.963
3/4	6	1.502	.750	.44	2.356
7/8	7	2.044	.875	.60	2.749
1	8	2.670	1.000	.79	3.142
1	9	3.400	1.128	1.00	3.544
1 1/8	10	4.303	1.270	1.27	3.990
1 1/4	11	5.313	1.410	1.56	4.430

The new bar numbers are based on the number of 1/8 inches included in the nominal diameter of the bar.
Bar number 2 is in plain rounds only. Bars numbered 9, 10 and 11 are round bars and equivalent in weight and nominal cross-sectional area to the old type 1", 1 1/8" and 1 1/4" square bars.

The above weights are adopted as standards by the Institute in 1934 and supersede former practice. These weights have been approved through the U.S. Department of Commerce Simplified Practice Recommendation R 26-50.

NEW BAR NUMBERS

These denote the nominal diameter of the bar in eighths of an inch. Thus, a #3 bar (nominal diameter 3/8") has the same weight per foot as a 3/8" plain round bar. Bars #9, 10, and 11 are an exception to this rule. See details below.

NO MORE SQUARE BARS

Bars #9, 10, and 11 are round bars equivalent in weight and nominal cross-sectional area to the former 1", 1 1/8", and 1 1/4" square bars.

Write for Your FREE Copy of this New Bar Card

CONCRETE REINFORCING STEEL INSTITUTE • 38 S. Dearborn St., Chicago 3

the **3** most important factors to consider when choosing **woodwork** —

"BILT-WELL" Products have all 3

- 1 **FINE WORKMANSHIP**—carefully and sturdily constructed by experienced, skilled woodworkers.
- 2 **HIGH GRADE MATERIAL**—clear, kiln-dried Ponderosa Pine scientifically treated with NWMA approved toxic water-repellent preservative solution.
- 3 **ARCHITECTURALLY CORRECT DESIGNS**—appropriate adaptations for popular homes. These are the extra value points that mean added years of comfort, convenience and economy. They are important because they insure your investment. Insist on Bilt-Well Products.

NU-STYLE UNIT WOOD KITCHEN CABINETS

there are units to fit any size or shape of kitchen



CEILING UNITS
UPPER UNITS
SINK UNITS
LOWER UNITS
STORAGE UNITS

SMOOTH STYLING
DOVETAILED DRAWERS
EXTRA DEEP DRAWERS
CAN BE FINISHED IN ANY COLOR
SIMPLE TO REDECORATE
TAKES NATURAL FINISH
EASY TO INSTALL



EASY TO ASSEMBLE
Nu-Style Cabinets are so easy to assemble. Homeowners, Hobbyists and Handymen find them simple to set-up. A hammer and a screw driver are the only tools needed to assemble Nu-Style Cabinets.

SUPERIOR UNIT WOOD WINDOWS





The durable ever-sliding Ponderosa Pine window unit with the built-in exclusive Superior Weatherstrip.



ALL BILT-WELL PRODUCTS ARE PACKAGED OR BUNDLED UNITS completely machined, ready to set up and paint.



The Willayne Terrace Apartments, Lafayette, Indiana. Mr. L. A. Thise, Contractor, installed Superior Unit Wood Windows, Nu-Style Cabinets and other Bilt-Well Products throughout.



CARR, ADAMS & COLLIER CO. Dubuque, Iowa

Manufacturers of the Famous Bilt-Well Line • Mantels & Telephone Cabinets • Multiple-Use & Linen Cabinets • Stair Parts • Nu-Style Cabinets • Superior Unit Wood Windows • Exterior & Interior Doors • Entrances • Shutters • Clos-tite Casements • Carr-dor Garage Doors • Basement Unit Windows • Louvers & Gable Sash • Breakfast Nooks • Combination Doors • Screens & Storm Sash • Corner (China) Cabinets • Gli-dor Cabinets • Ironing Board Cabinets

heating costs go down...
stay down...with

"METRO"

SINGLE-RISER HEATING

Single-riser provides an uninterrupted path for flow of steam from top to bottom of building. A continuous pipe passes down through overlying rooms . . . is offset in each room into a convector or baseboard.

Here's why "Metro" piping is used in large scale housing projects financed by the Metropolitan, Equitable and New York Life Insurance Companies.

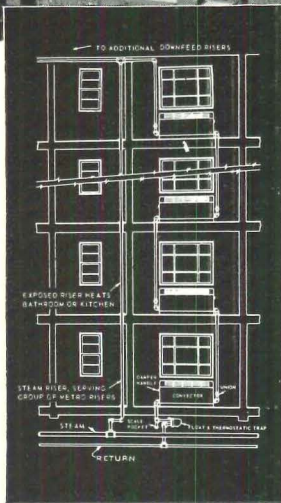

"METRO" costs less to install.

No expensive radiator branches and expansion joints needed. No costly furring of walls or ceilings. Risers can be pre-cut, all one size, in shop.

"METRO" costs less to operate.

Heat supply and demand are always in perfect balance because "Metro" uses a continuous flow of steam at variable sub-atmospheric pressures and temperatures that vary automatically with outside weather. No need for tenants to turn radiator valves on and off . . . their rooms are automatically maintained at peak comfort.

"METRO" costs less to maintain.

No radiator traps and valves in occupied spaces. Single trap at bottom of riser in basement can be serviced without disturbing tenants. No small radiator fittings to break down.

**Variable Vacuum.*

CONVECTOR RADIATION, BASEBOARD RADIATION

UNIT HEATERS

DUNHAM
HEATING SYSTEMS AND EQUIPMENT

FIN-VECTOR RADIATION

PUMPS, TRAPS, VALVES

Living room in Stuyvesant Town Housing Project showing attractive "Metro" convector. "Metro" piping is concealed behind draperies.

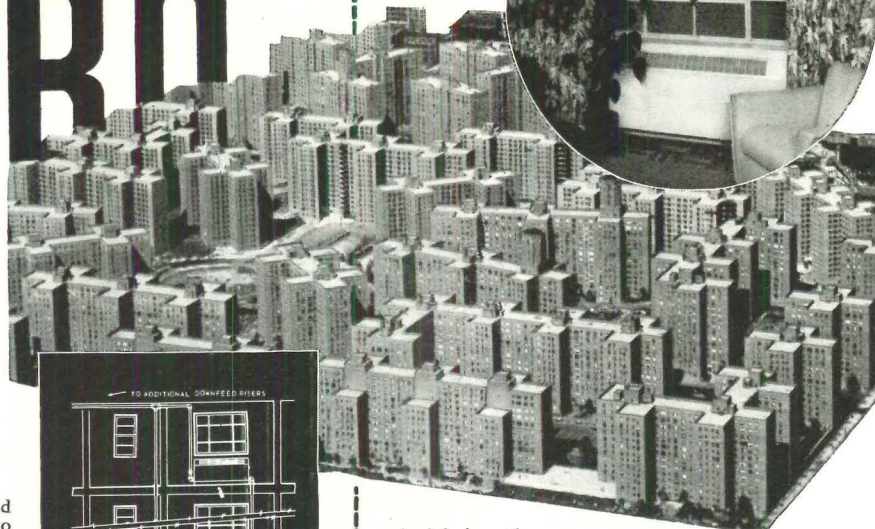
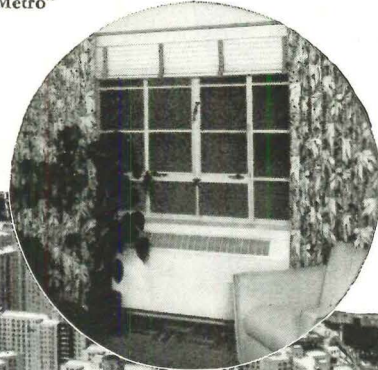

Aerial view of Stuyvesant Town (foreground) and adjacent Peter Cooper Village, New York.

Dunham Vari-Vac Differential Heating . . . the system that controls "Metro" . . . cuts fuel costs up to 40%. Vari-Vac* is adaptable to any size or type of building . . . any climate. A Dunham Sales Engineer can help you specify the particular type of system — capacity-wise — that will meet your requirements.

SEND FOR FREE BULLETIN

For complete information about economical "Metro" single-riser heating, write today for your copy of Bulletin 643-5. C. A. Dunham Co., 400 W. Madison St., Chicago 6, Ill. In Canada: C. A. Dunham Co. Ltd., Toronto. In England: C. A. Dunham Co. Ltd., London.

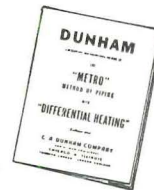

YOU CAN BE **SURE**... IF IT'S
Westinghouse

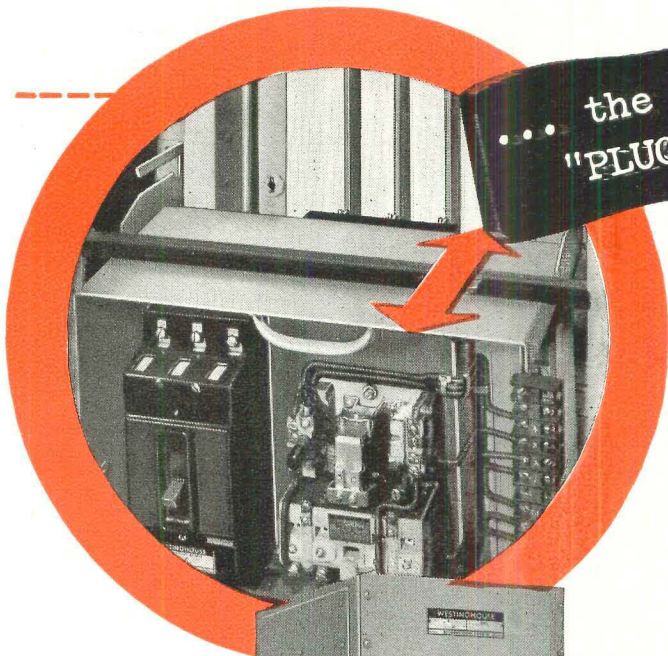

... the greatest advancement in
"PLUG IN" control center design

"TILT POSITION" DISCONNECT

for unmatched safety

With the new Westinghouse Control Center you can be *sure* about safety... because it's *the safest control center ever built!*

This important advantage results largely from these two remarkable features:

"Tilt position" disconnect: Starter units may be withdrawn to a self-supporting "tilt position" which completely disconnects them from the power bus. It is physically impossible to reach the bus when the starter is in this position.

Safety interlocking handles prevent opening of the starter doors unless the circuit breaker is in the "Off" position. Starter doors may be "locked safe" with from one to three padlocks to prevent entrance by unauthorized personnel.

Consider all the advantages of this new control center!

New Magna-Grip "plug-in" connectors contribute to greater safety... and new operating convenience; standardized, modular dimensions for unmatched flexibility; a large vertical wiring trough for easier wiring and maintenance. These are random examples. The complete story is in Booklet B-4213. For your copy, write to Westinghouse Electric Corporation, P. O. Box 868, Pittsburgh 30, Pa. J-21544

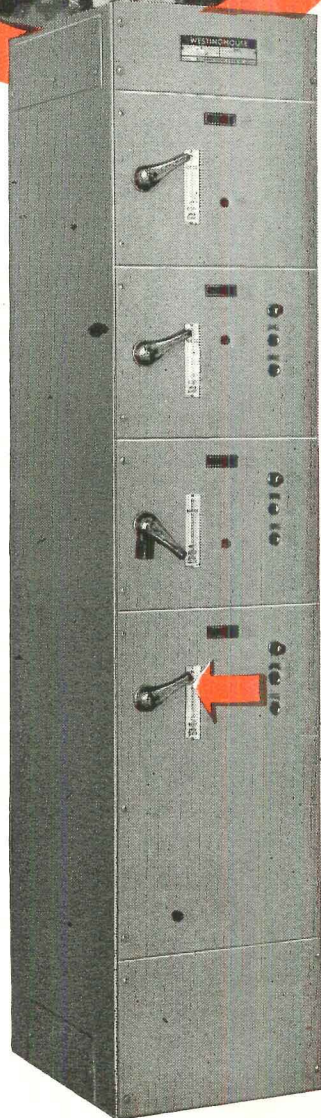

Westinghouse 

**CONTROL
CENTERS**

HIDE the hardware... says

FRANK LLOYD WRIGHT

"My efforts since I've been practicing for myself, is to get rid of it. The less hardware that is in evidence, the better. The more you get the hardware out of sight, and make less of it, the more you are going to be modern and in line with modern architecture."

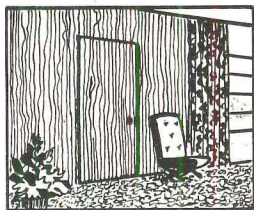

IDEAL FOR FLUSH DOORS

"The less hardware that is in evidence the better."
The Soss Invisible Hinge is also known as "the hinge that hides itself."

"Hardware is still too ornamental—it isn't sufficiently simple."

What could be less ornamental or more simple than something you can't see—like the Soss Invisible Hinge?

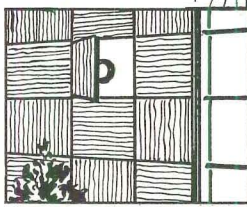

PERFECT FOR WALL PANELS

"Hardware should be something that really works and should be out of sight—"

Soss Hinges "really work" smoothly and quietly on hardened steel roller bearings.

★ All quotes taken from Mr. Wright's address before the Pacific Coast members of the American Society of Architectural Hardware Consultants and the National Contract Hardware Association at the Arizona Biltmore in Phoenix, Arizona.

SOSS Invisible HINGE

Write for FREE CATALOG that gives complete details, blueprint templates, and the many uses of this modern hinge to...

SOSS MANUFACTURING COMPANY
21779 HOOVER ROAD • DETROIT 13, MICHIGAN

A.I.A. File No. 27-B-1

LETTERS

mortgage credit so easy during the past year that it was primarily responsible for causing more building to be undertaken than there were materials to build the houses and labor to erect them? The inevitable result was an inflationary boom in the prices of building materials and in building labor.

Did this benefit veterans or anyone else for that matter except those who may have reaped an undue profit from the rising prices?

Although Regulation X, if kept in force long enough, would certainly cause a decline in new house building, I can find no available statistics as yet to show what the actual effects of this regulation have been to date. Real estate loans of commercial banks are still continuing their uninterrupted rise. In the four weeks ending November 8, real estate loans of banks in 93 principal cities outside New York rose \$56,000,000, approximately twice the increase recorded in the comparable period a year ago.

At a time like this when a severe manpower shortage is going to be inevitable by next Spring and when the demand for houses is going to contract because of the doubling up which will inevitably result from married men going into the armed services, what could be more ill-advised than to have the Government continue to foster an unnecessary building boom? I am sorry to see Building even inadvertently give support to those who for selfish reasons are trying to undermine Regulation X.

CLAUDE L. BENNER, *President*
Continental American Life Insurance Co.
Wilmington, Del.

• BUILDING agrees with Reader Benner that the curb on mortgage finance was necessary, but believes that it was tighter than necessary. However, the argument now seems academic for, in the light of recent developments, it appears that prospective material shortages may have a greater braking effect on house building than Regulation X.—ED.

BRICKS AND A-BOMBS

BUILDING:

I compliment BUILDING on the timely November article dealing with building design for A-Bomb blast resistance. It is too bad that data of this sort could not have been made generally available earlier so that many of the essential structures built in the past five years would be more durable in the event of atomic warfare.

In the interests of technical accuracy, I believe it should be pointed out that there is no apparent evidence in the AEC Report that reinforced brick masonry would not be a satisfactory construction for blast resistance. This type of construction is approved by the building codes for the severe earthquake areas in California and has been very widely employed. Lateral resistance and load-bearing characteristics are fully equivalent to the properties of the reinforced concrete construc-

(Continued on page 66)

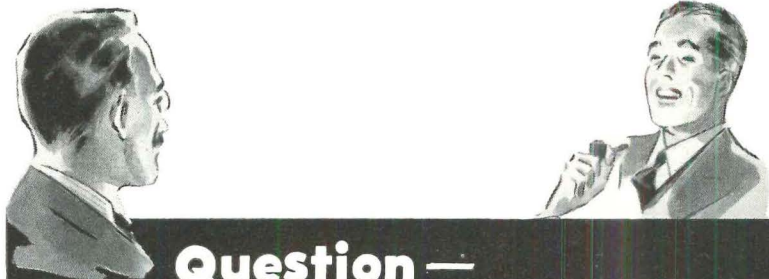

Question —
Why is PAINE REZO
T. M. REGISTERED
the door that it is

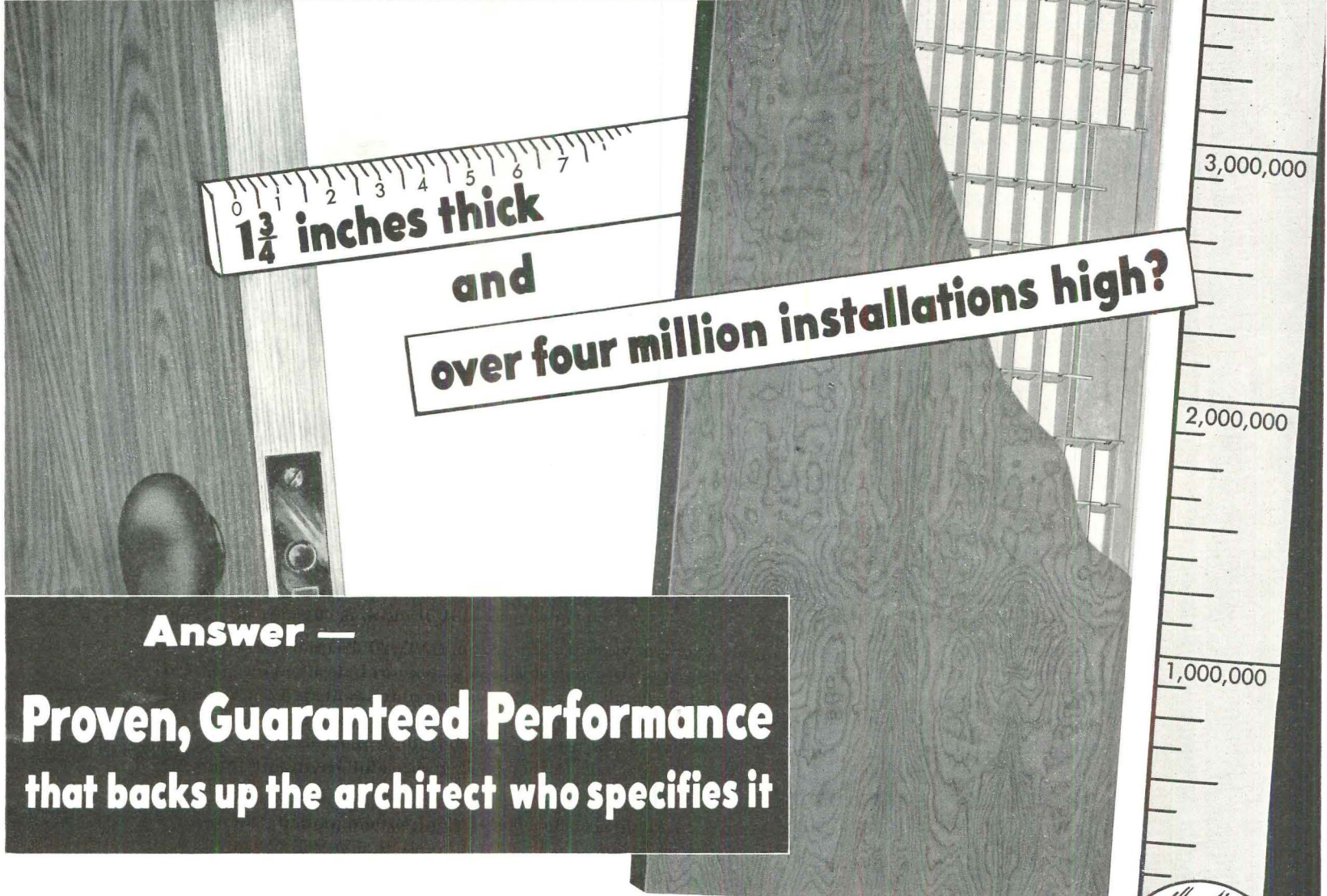

1 3/4 inches thick

and
over four million installations high?

Answer —
Proven, Guaranteed Performance
that backs up the architect who specifies it

In all of the construction industry, there is no door like the Paine Rezo . . . no door that combines the great strength of the interlocking wood Rezo core with lightness in weight, no door that is the equal of the Rezo in dimensional stability, no door that performs so well anywhere and everywhere that it carries an unconditional guarantee of satisfactory service.

A 1 3/4-inch thickness is the minimum required to provide this structural strength that responsible builders have wanted more than four million times — a demand that has made Paine the world's largest exclusive manufacturer of flush air cell doors. Write today for full information.

Manufactured by the
PAINE LUMBER CO., LTD. *Oshkosh Wisconsin*
ESTABLISHED 1853

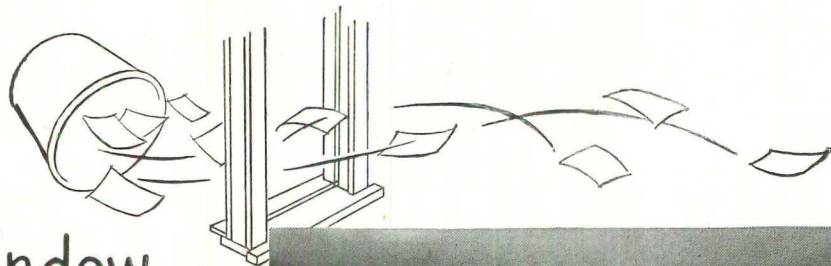

Out the window went all existing ideas!

"Throw away all existing ideas about casements. Start from scratch and develop a unit that is better than anything else on the market."

That was the order we gave our engineers and research men. The result: the Curtis Silentite Casement. Here's why we believe no other casement can match it:

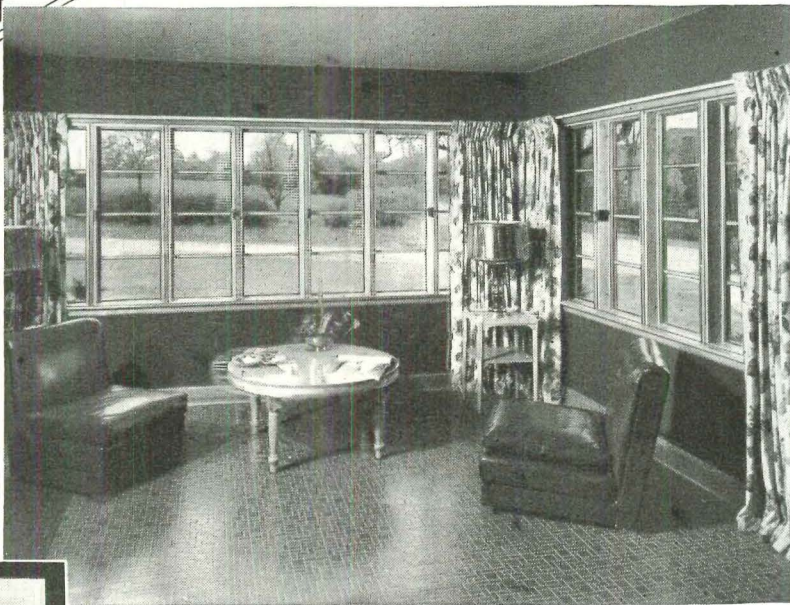

● **A COMPLETE UNIT**—with all parts pre-fitted—consisting of frame, sash, all operating hardware, insulating glass, screen and Miterite trim. The illustration shows small unit with part of trim cut away to show how operating mechanism holds sash firmly in any position without rattling, swinging or vibrating.

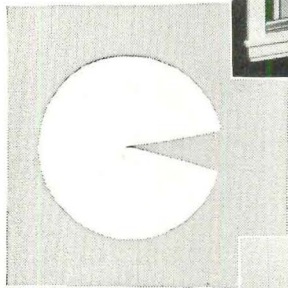

● **MORE WEATHERTIGHT**—repeated tests show that Silentite wood casements cut total heating costs in a house about 16%—thanks to scientific weatherstripping and insulating glass, which serve as storm sash.

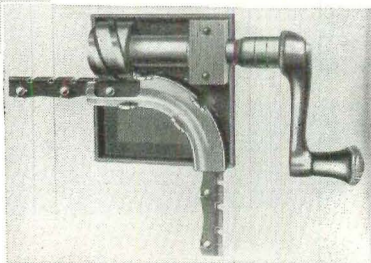

● **EASY OPERATION**—this special Curtis hardware provides 15 times the operating force available with the ordinary lever-type casement sash adjuster. There is no hardware on outside of frame or sash when casement is closed and the minimum of exposed hardware inside. Adjuster is removable.

● **PLUS**—Toxic water repellent treatment of all wood parts—reduced condensation—no sticking, binding or warping—quick, easy installation.

*Curtis makes a complete line of
woodwork for homes of all types and
sizes. Make your next house "all Curtis."*



Mail the coupon for full information

Curtis Companies Service Bureau
MB-1S Curtis Building
Clinton, Iowa

Gentlemen: I want to know more about Curtis Silentite casements, basement units and Silentite double hung windows.

Name.....

Address.....

City.....State.....

QUALITY CONTROLLED

MA-TI-CO
TILE FLOORING

REPLACEMENT OR REFUND OF MONEY
Guaranteed by
Good Housekeeping
IF NOT AS ADVERTISED THEREIN

PROVED IN IMPORTANT PROJECTS THE COUNTRY OVER!

Now MATICO delivers outstanding performance in famous Oak Ridge

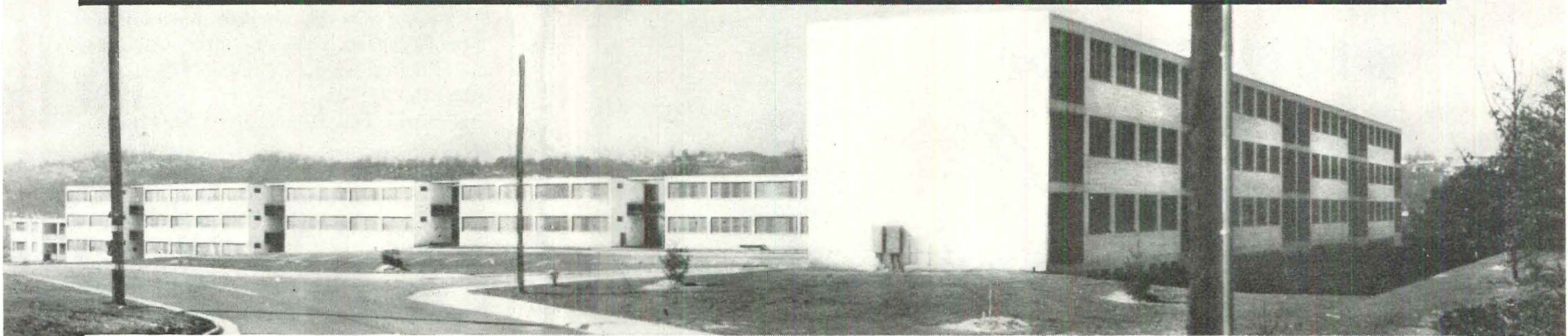

Finest quality . . . long-lasting wear . . . greater economy . . . resilience underfoot . . . easier, faster installation . . . enduring beauty . . . these are the outstanding advantages that make MATICO Asphalt Tile ideal for every type of installation. And in important projects throughout the country MATICO is proving its superior quality by on-the-job performance. Included in this list of projects are such well-known names as Bond Clothing Co., Philco Radio Corp., General Electric Co., Metropolitan Life Insurance Co., and Fort Hamilton Veterans Administration Hospital (where MATICO was used throughout).

There is no stronger proof of MATICO quality than the selection of MATICO Asphalt Tile—time after time—for use in America's foremost industrial plants, institutions, government buildings, apartment developments and housing projects.

Be sure to specify MATICO when next you order asphalt tile flooring . . . it's the most economical, serviceable type of luxury flooring you can choose.

GET TO KNOW MATICO

Consult our insert in Sweet's file Architectural Section 13g. For free samples write on your business stationery.

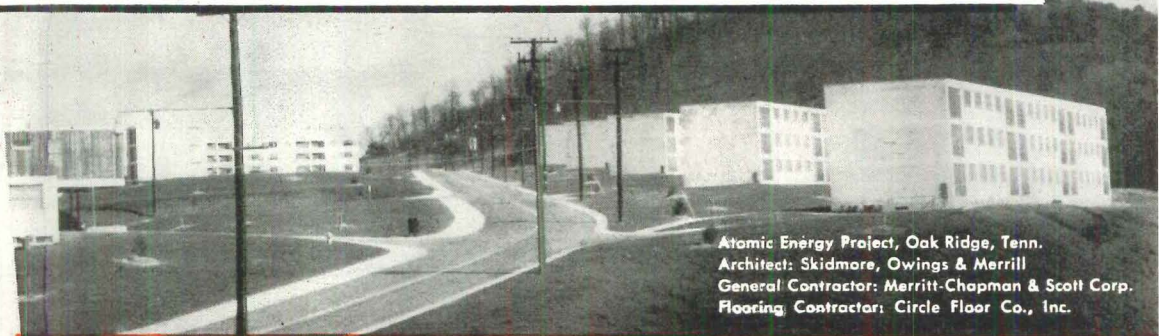
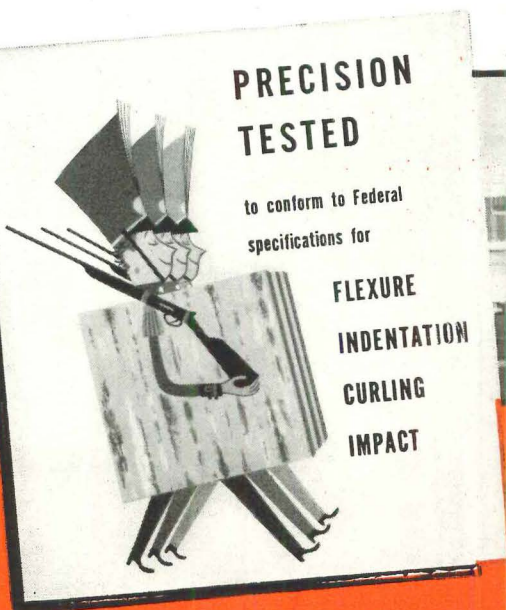

Atomic Energy Project, Oak Ridge, Tenn.
Architect: Skidmore, Owings & Merrill
General Contractor: Merritt-Chapman & Scott Corp.
Flooring Contractor: Circle Floor Co., Inc.

DEPT. 61

MASTIC TILE CORPORATION OF AMERICA

Member: Asphalt Tile Institute

Factories: Newburgh, N. Y.

Long Beach, Calif.



**BE SURE
TO SEE . . .**

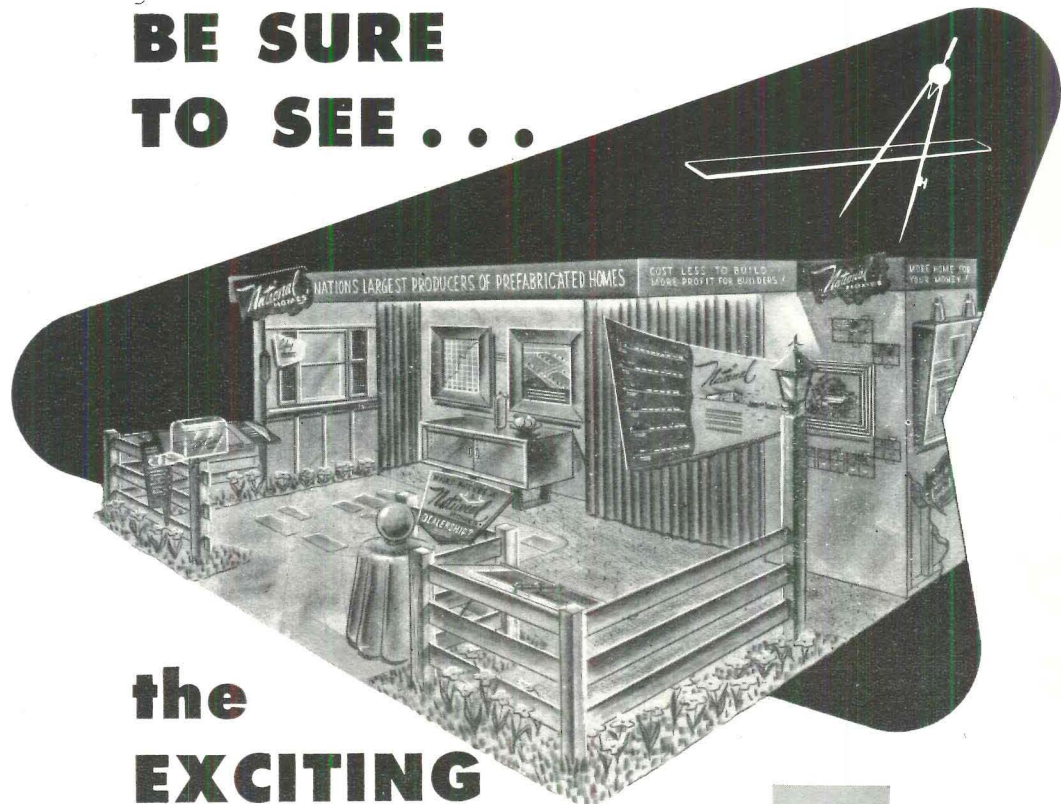

**the
EXCITING
DISPLAY for**

National
HOMES

at the NAHB Convention!

Remember last year's Home Builders Show? The magnet was the National Homes booth, jammed constantly with people eager to get the facts about the nation's largest producers of prefabricated homes. This year's display will be even more interesting. Don't miss it. See why National Homes are the leaders in sales, in satisfied customers, in enthusiastic dealers!

*Nation's Largest Producers
of Prefabricated Homes . . .*

SPACES 94-95
at the STEVENS

NATIONAL HOMES Corporation • Lafayette, Ind.
EASTERN PLANT . . . HORSEHEADS, NEW YORK

LETTERS

tion recommended by the AEC as the only suitable type of design. . . .

ROBERT B. TAYLOR
*Director of Research
Structural Clay Products
Research Foundation
Chicago, Ill.*

KUDOS

BUILDING:

I thought so much of the October article which dealt with the replacement and remodeling problems of hospitals that I have made it available to members of our Board of Managers and key people in the hospital because of the pertinence of the observations to our problems. . . .

LLOYD GASTON, M.D.
*Executive Director
St. Luke's Hospital
New York, N. Y.*

BUILDING:

We appreciate the excellent *News* coverage in the November issue of the general situation and of the conferences with the NPA in particular (p. 9); also of Fritz Gutheim's discussion with Jack Egan at the NAHO meeting (p. 16).

NED PURVES
*Executive Director
American Institute of Architects
Washington, D. C.*

BUILDING:

Your articles on the architecture of the Mediterranean by Kidder Smith have been of great interest to me and I greatly admire the work that he is doing.

I hope you are thinking of publishing this group of articles in book form. . . .

NILS F. LARSON
Ithaca, N. Y.

• Smith's architectural reports from the Mediterranean will probably be the basis for a book on this subject by the author.—Ed.

BUILDING:

We congratulate you on your new name, also on the excellent quality of the editorial contents.

But we take a very small exception to a figure on page 131 of your October issue . . . architectural porcelain does not weight 10 to 15 lbs. per sq. ft. as indicated. It weighs between 3 to 4 lbs. per sq. ft., unless the material is backed up with a heavy aggregate. . . .

HUGH V. PENTON
*California Metal Enameling Co.
Los Angeles, Calif.*

• The panels described by BUILDING were so backed up.—Ed.

ERRATA

The house presented on page 119 of the November issue was built by Albert (not Walter) Lowery of San Antonio.—Ed.

Distinguished Design by **MR. FRANK LLOYD WRIGHT**

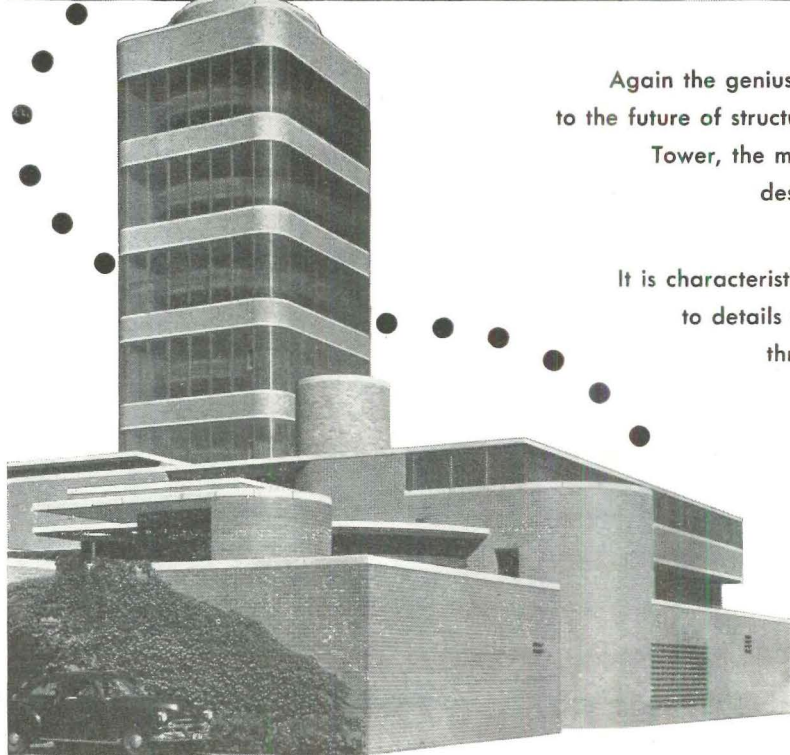

2TB51

Again the genius of Mr. Frank Lloyd Wright is responsible for a major contribution to the future of structural design...the unique and dramatic Research and Development Tower, the most recent addition to the group of interesting buildings previously designed by Mr. Wright for S. C. Johnson & Son, Inc., world-famous manufacturers of wax products at Racine, Wisconsin.

It is characteristic of Mr. Wright's approach that his influence carries through even to details of equipment. This was the case with the ceiling diffusers installed throughout the Tower... and we are proud that we were selected to manufacture to the specifications of Mr. Wright, special Type H Aerofuse Diffusers combined with light fixtures.

TUTTLE & BAILEY inc

NEW BRITAIN, CONNECTICUT

Manufacturers of Aerofuse Diffusers,
Tri-Flex and Aerovane Grilles and Registers



MALARKEY PLYWOODS AND DOORS

**Showing your customers
how to . . .**

Modernize
with this handy
wardrobe closet

This Malarkey advertisement will be seen in the *Saturday Evening Post*, January 27, 1951, *Better Homes and Gardens*, March 1951 and Summer-Fall edition of *Small Homes Guide*.

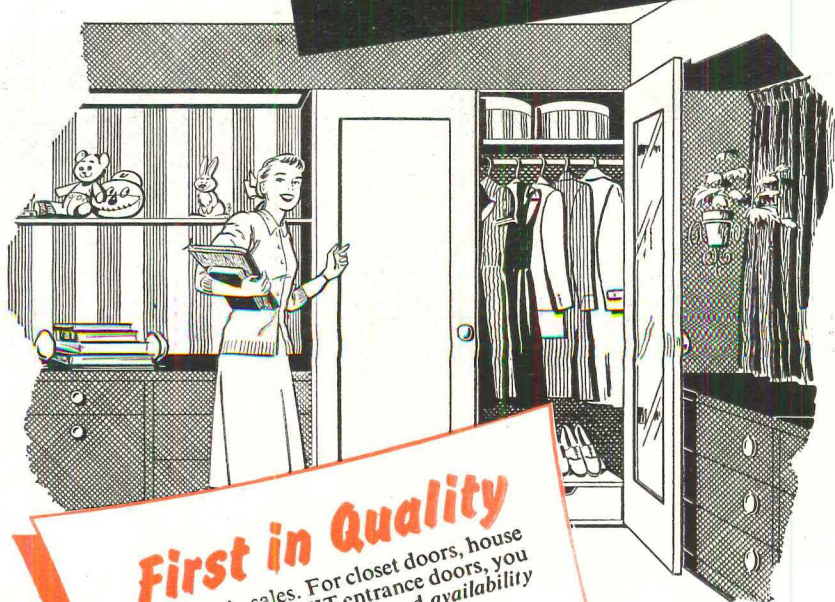

First in Quality

and first in sales. For closet doors, house doors and TRUFIT entrance doors, you can be certain of *quality and availability* when you *specify Malarkey doors*.

SAVE \$\$\$ For a small additional charge Malarkey doors can be ordered factory prefit and resin-sealed. On large projects doors can be prepared for hardware and hinges, reducing your on-the-job costs.

Malarkey doors are sold by building supply dealers throughout the United States. Send for catalog "Malarkey Doors" and name of distributor in your area.

Modernize! That's what many American families are going to do this year. Maybe credit and building restrictions have halted their new home plans, but they can still remodel their present home, add a wing, or fix over an unused attic.

We are urging American families to do just that and are providing them, through the Malarkey House advertising, with up-to-the-minute ideas to make their homes more comfortable, convenient and attractive.

THEY WILL COME TO YOU for advice and assistance in planning, building or financing. In these times of critical supply of building materials you will undoubtedly recommend those quality materials that are available, such as economical Malarkey panel or flush doors which add the finishing touch to the new wardrobe closet.

Send today for a list of Malarkey door distributors in your area and the catalog of Malarkey doors.

Detail plans and specifications for *Kitchen, Bedroom, Living Room, Play Area and Wardrobe Closet* will be sent for 10¢ each.



**Look for the MALARKEY
RED DIAMOND TRADEMARK**

Malarkey doors are easily identified by protective metal gliders on the bottom of the doors. They bear the familiar Malarkey Red Diamond trademark which is your assurance that you get what you specify . . . Malarkey doors.

M and M Wood Working Company

2331 N. COLUMBIA BOULEVARD • PORTLAND 17, OREGON



George Cooper Rudolph, A.I.A.

a Girl's Bedroom

MALARKEY HOUSE

Even though your new home may be delayed by credit and building restrictions, you can still *modernize your present home*. Why not remodel a room, add a wing, or finish an unused attic? For example, your growing daughter would like a room as shown above. Feminine, yet functional, this room can grow up with the girl, thanks to foresighted design made possible by use of Malarkey doors and plywoods. It can be adapted to the needs of any girl from 6 to 26.

Plenty of convenient built-ins and closets inspire neatness and encourage pride in taking care of clothing and possessions. Behind the wardrobe closet doors, for instance, are various size drawers and clothes rod that can be raised as the girl grows. The Malarkey one panel door was selected so that a full length mirror could be mounted on the inside. This door is one of Malarkey's wide variety of beautiful detail fir doors at economical stock door prices.

In correct styles for every type of architecture, and in sizes to fit every opening.

Malarkey doors and plywoods are the perfect materials for creating individual rooms, allowing you to have the full enjoyment of your home. They can be finished to your liking. You can modernize without upsetting the household. There's no fuss . . . no mess with Malarkey plywood and doors. A home carpenter can often do the work.

Your architect, interior decorator, builder or lumber dealer will help you select the Malarkey doors and plywoods for your remodeling or building job.

Send 10c for plans of wardrobe closet shown in Girl's Bedroom above. Includes detailed drawings, specifications and complete bill of materials. Easy for you or your builder to follow. M and M Wood Working Company, 2311 N. Columbia Boulevard, Portland 17, Oregon.



Modernize present rooms or add new ones. With Malarkey plywoods and doors you can "tailor" your rooms to fit your needs. In this girl's bedroom a regulation-size dressing table is provided to encourage good grooming.

Handy Wardrobe Closet

Drawers of wardrobe are graduated to store various foldables. Toy chest can be used as hope chest later, doll collection shelf for books. Attractive plywood valances give soft indirect lighting over the bed and dressing table. The built-in radio-phonograph provides entertainment for girls of all ages. Convenient built-ins go clear to the floor, reduce cleaning and maintenance chores.

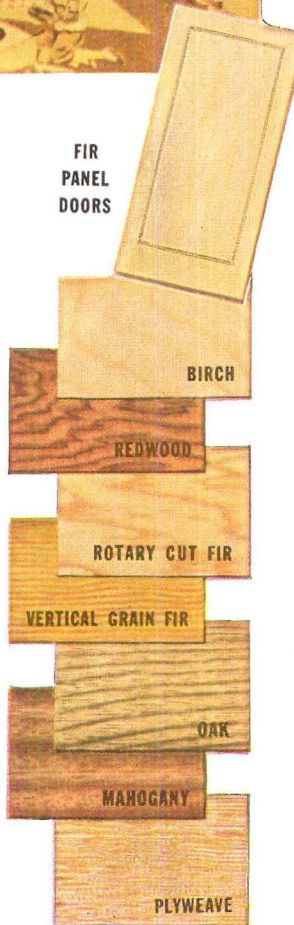

Malarkey plywoods and doors

Look for the Malarkey red diamond trademark

1818 HOPE'S 1951

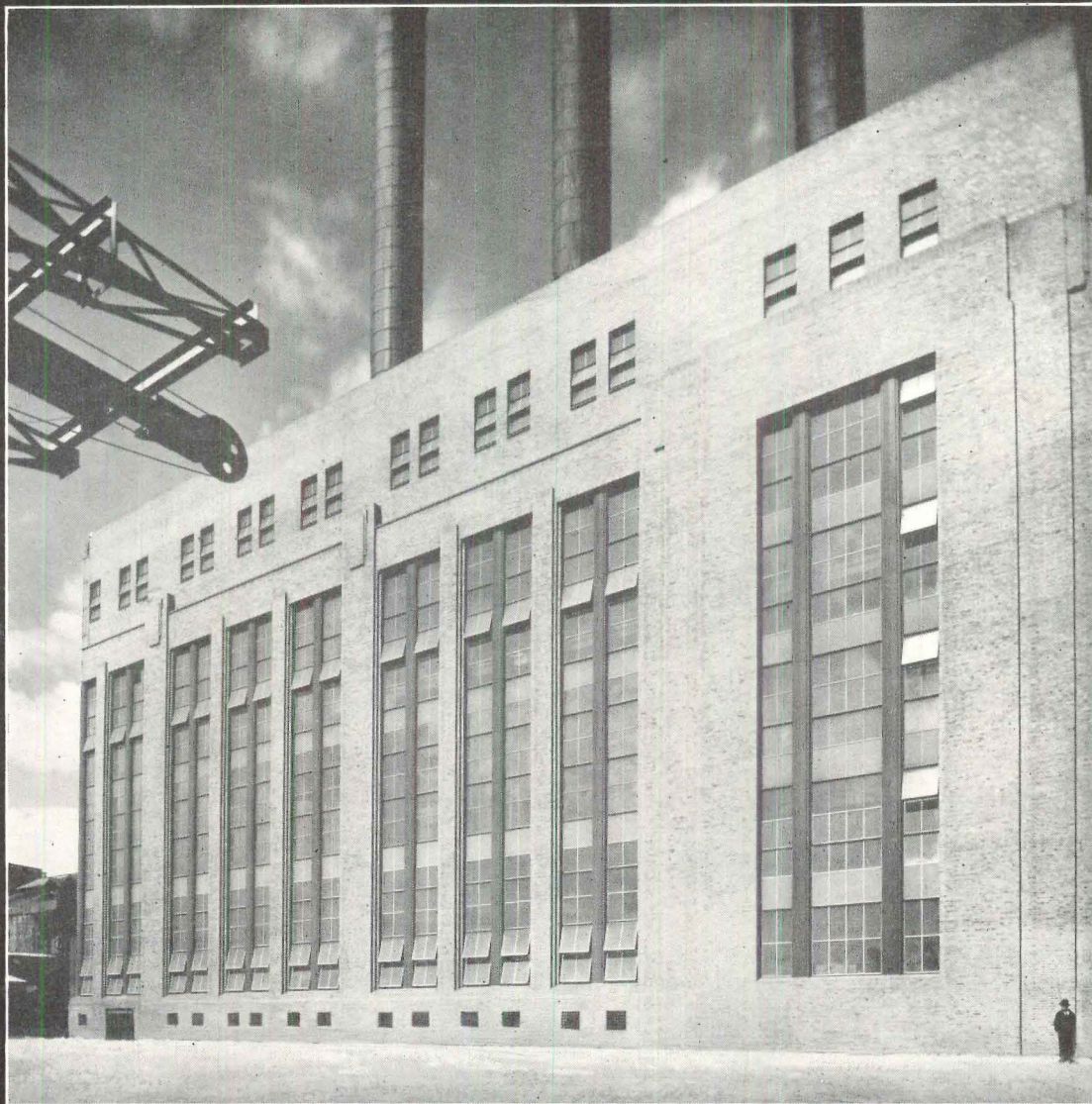

Ocker Hill Power Station

THE HOPE'S *LOK'D BAR* FACTORY SASH recently installed in this Power Station building are made to special size and layout. Their height, 63', 0", is indicated by the size of the figure in the lower right foreground. The mullions are 10 gauge pressed steel reinforced by structural members. Hope's *LOK'D BAR* Catalog describes, with full-scale drawings, the exclusive principle of their design, and Hope's Engineering Department will be glad to submit details for similar installations on request.

HOPE'S WINDOWS, INC., *Jamestown, N. Y.*

THE FINEST BUILDINGS THROUGHOUT THE WORLD ARE FITTED WITH HOPE'S WINDOWS

TOILET ROOM ENVIRONMENTS THAT STAY NEW ALWAYS!

Sanymetal CENTURY Type Ceiling Hung Toilet Compartments offer the utmost in sanitation and provide modern, distinctive toilet room environments for schools, institutions, terminals and other public buildings.

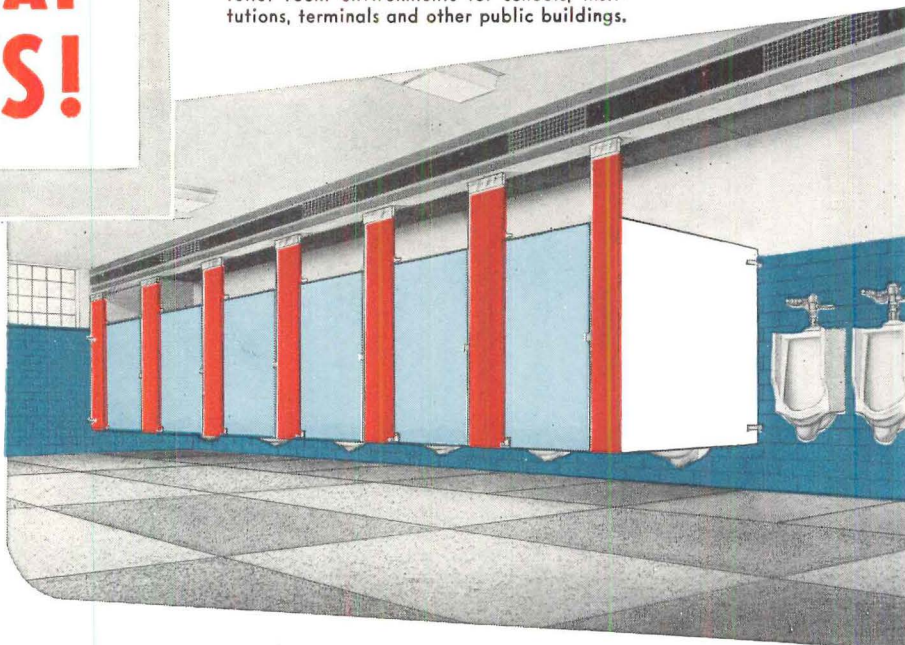

● The toilet room environment that stays new is the toilet room in which the most suitable type of toilet compartment available has been installed. Toilet compartments usually dominate a toilet room, influence the toilet room environment and emphasize the utility of fixtures and appointments. The bare functional type of toilet room is inadequate according to today's standards.

Sanymetal offers several different types of toilet compartments for creating the most suitable toilet room environment for every type of building. Sanymetal also offers and recommends Two Full Purpose Metal Base Materials which combine colorful attractiveness with long years of service life and effect important, day after day, savings in cleaning and maintenance cost. These Two Full Purpose Metal Base Materials—Sanymetal "Tenac" (galvanized, Bonderized* steel), a highly corrosion-resistant material; and Sanymetal "Porcena" (porcelain on steel), the ageless and fadeless, rust proof material—represent years of engineering research and skillful adaptation by Sanymetal engineers of corrosion-resistant steels to the fabrication of new and different types of toilet compartments.

THE SANYMETAL PRODUCTS CO., INC.
1687 Urbana Road • Cleveland 12, Ohio

Over 150,000 Sanymetal installations have been made in all types of buildings. Ask the Sanymetal representative in your vicinity for information about planning suitable toilet room environments that will always stay new. Refer to Sanymetal Catalog 22b in Sweet's Architectural File for 1950.

5

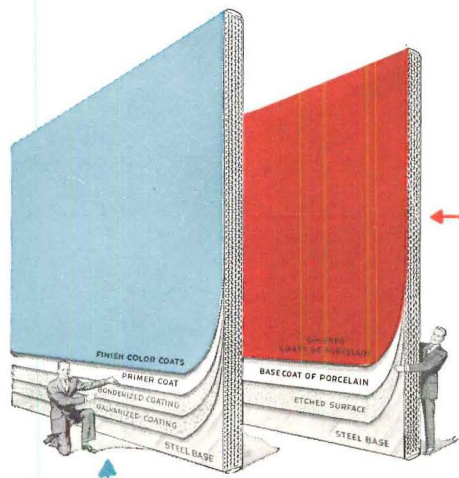
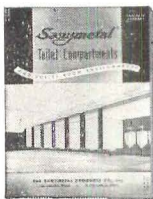

This is Sanymetal **"PORCENA"**
(Porcelain on Steel)

A metal base material that is impervious to moisture, odors, cleaning and uric acids, oils and grease. It is rust proof. Available in 21 glistening colors.

This is Sanymetal **"TENAC"**

(Baked-On Paint Enamel over Galvanized, Bonderized* Steel)

A metal base material that is notable for the positive adhesion of the baked-on paint enamel to the metal and its resistance to corrosion. Its lustrous, protective finish assures long-lasting newness. Available in 21 gleaming colors.

Sanymetal

*Trade Mark Reg. U. S. Pat. Off.

*Treated with "Bonderite", a product of Parker Rust Proof Co.

TOILET COMPARTMENTS, SHOWER STALLS AND DRESSING ROOMS

Sanymetal ACADEMY Type Shower Stalls and Dressing Room Compartments provide the utmost in sanitation for gymnasiums, stadium dressing rooms, Y.M.C.A.'s, clubs, trailer camps and tourist motels, etc.

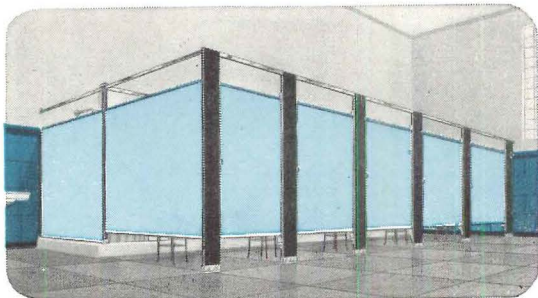

Sanymetal NORMANDIE Type Toilet Compartments endow a toilet room environment with dignity and good taste.

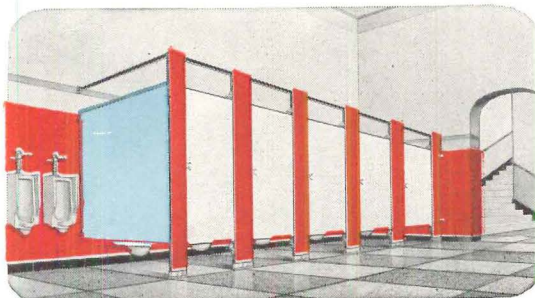
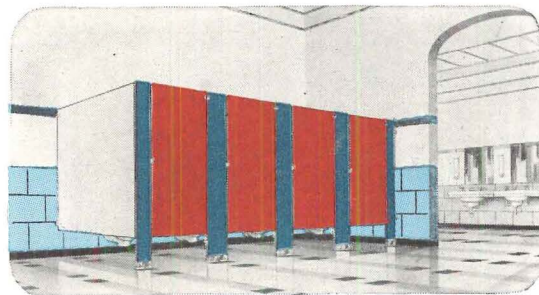

Sanymetal ACADEMY Type Toilet Compartments are suitable for conservative but modern toilet room environments.



Trifari Jewels—Showroom—New York City, Satinwood Flexwood, Architect—Kahn & Jacobs.

How **FLEXWOOD SOLVES**

“WALL DECORATING” *problems . . .*

PROBLEM. How to have “style” and “sparkle” in a jewelry showroom—along with a rich, warm, comfortable atmosphere.

SOLUTION. Curved walls provide smartness and grace, enriched with exquisitely matched Satinwood Flexwood—resulting in a perfect background of beauty.

Many problems with columns, flat walls, broken surfaces—are solved magnificently with Flexwood.

SEND COUPON BELOW. See exactly how Flexwood* helped solve specific problems.

flexwood
CHOICE WOOD IN FLEXIBLE SHEETS

United States Plywood Corporation
55 West 44th Street, N. Y. 18, N. Y.
In Canada: Paul Collet & Co., Ltd., Montreal
Flexwood is manufactured and
marketed jointly by United States
Plywood Corporation and
The Mengel Company.

*Reg. U. S. Pat. Off.

United States Plywood Corporation, Dept. W-4
55 West 44th Street, New York 18, N. Y.

Please send me, without obligation, Flexwood's Case-History Book; shows how Flexwood helped solve 17 actual architectural problems.

NAME _____

ADDRESS _____

← *Prima Vera Flexwood.*

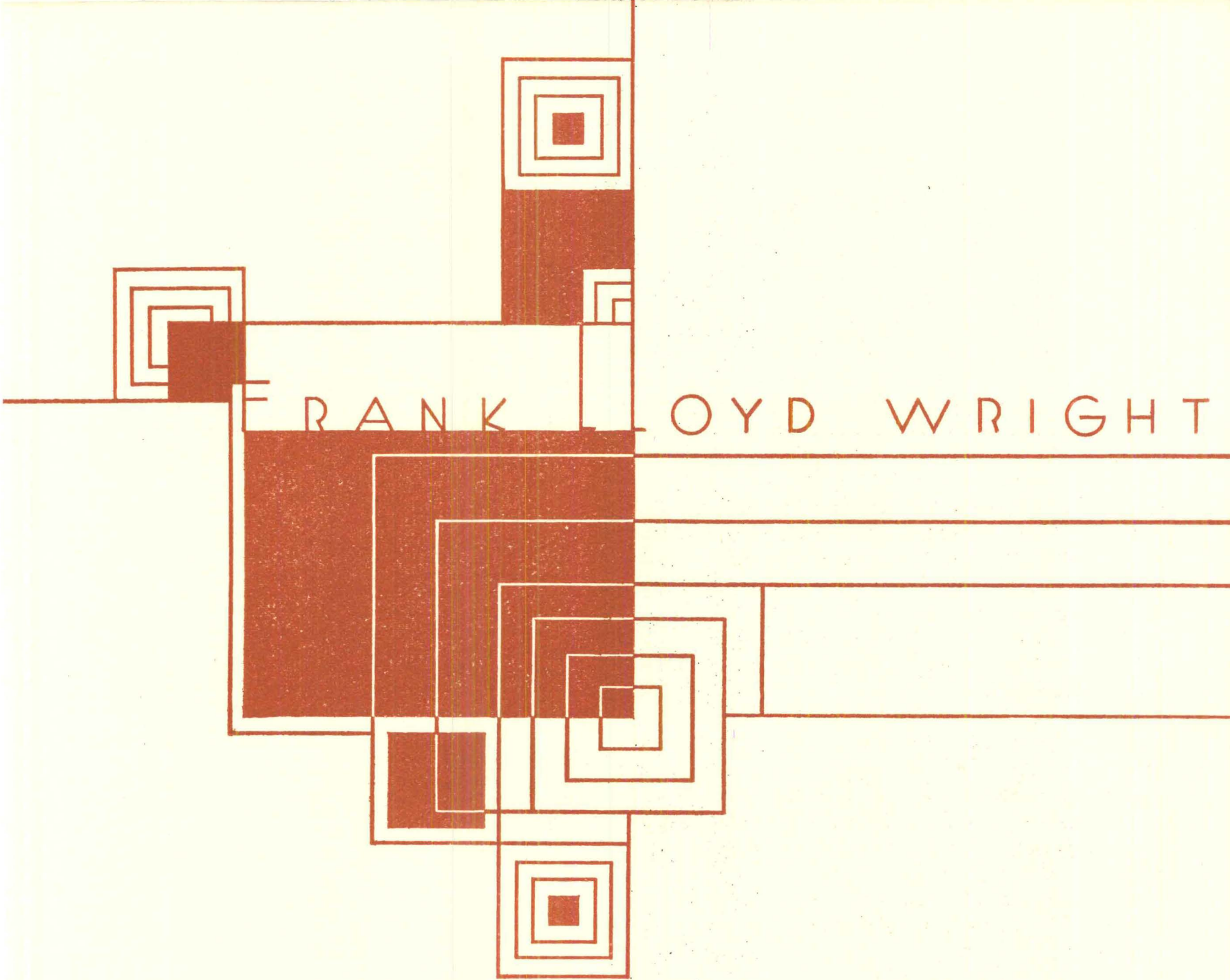

F R A N K L O Y D W R I G H T

WHATEVER HIS AGE . . . TO THE YOUNG MAN IN ARCHITECTURE

I hope by this continued, concentrated publication in Architectural Forum, the Magazine of BUILDING to rekindle enthusiasm for creative indigenous Architecture as against any cliché whatsoever. I am convinced, notwithstanding widespread imitation of effects only, that these works will eventually prove of lasting value to the younger architects of our modern times because of their integrity.

Like earlier publications of my work in this magazine in 1938 and again in 1948, I hope the buildings shown on the following pages, and selected from among many as worthy, will serve again to illustrate basic principles which give to them all such vitality, integrity and magic as they have. I still hope to see these basic principles more comprehended, therefore the effects imitated less. No man's work need resemble mine. If he understands the working of the principles behind the effects he sees here, with similar integrity he will have his own way of building.

Meantime preserve us from all istics, all ites, and any ism, especially naturalism. By way of style, preserve us above all, from a Style. Democracy deserves a free Architecture — at least Architecture free.

TALIESIN WEST DECEMBER 15, 1950
FRANK LLOYD WRIGHT

These pages of The Magazine of BUILDING will be reprinted and distributed in connection with a comprehensive exhibition of Frank Lloyd Wright's work assembled by Architect Oscar Stonorov and made available for showing both in this country and abroad through the generosity of Arthur C. Kaufmann, Executive Head of Gimbel Brothers, Philadelphia. The exhibition will include several hundred original FLLW drawings never before shown: drawings which constitute a remarkable record of the origin and development of modern architecture. First showing will be at the Gimbel Philadelphia store for one month beginning January 25. In response to a request from the Studio Italiano della Storia del'Arte, Palazzo Strozzi, the City of Florence and from Italian architects, the exhibition will then go to Florence, Italy. Later showings are scheduled for Zurich, Paris, London and Munich. For this reason, captions are translated into Italian, French, German and Russian on the last page.



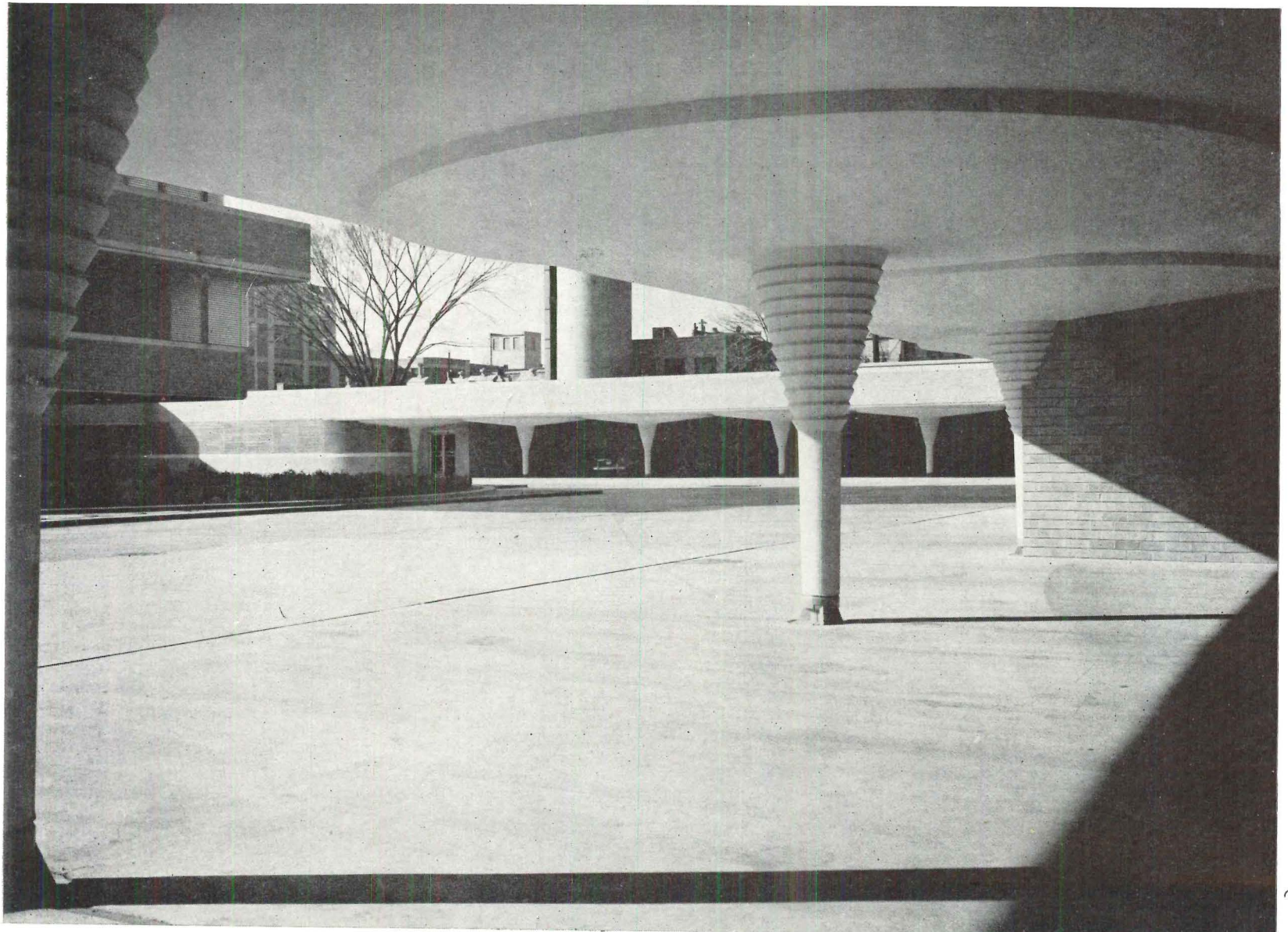

WHEN the matter of a new research laboratory came up at the S. C. Johnson Wax Co., Herbert Johnson said, "Why not go up in the air, Frank?"

"That's just it," I said. I had seen several of the meandering flat piles called laboratories, ducts running here, there and everywhere and a walkaround for everybody.

So we went up in the air around a giant central stack with floors branching from it having clear light and space all around each floor. All laboratory space was then net and in direct connection with a horizontal duct-system cast in the hollow, reinforced concrete floors, all connected to the vertical hollow of the stack itself.

This seemed to me to be a natural solution and this sun-centered laboratory we now call the Helio-lab came alive doing its own breathing and affording all kinds of delightful sun-lit, directly united, work space. Cantilevered from the giant stack, the floor slabs spread out like tree branches, providing sufficient segregation of departments vertically. Elevator and stairway channels up the central

stack link all these departments to each other. Like the cellular pattern of the tree trunk, all utilities and the many laboratory intake and exhaust pipes run up and down in their own central utility grooves.

From each alternate floor slab an outer glass shell hangs firm. This glass shell, like that of the original administration building is formed of glass tubes laid up like brickwork outside, here held in place by small vertical cast aluminum stanchions and sealed horizontally by a new plastic. Inside this outer screen for temperature insurance a plate glass screen was clipped to the aluminum stanchions of the tube walls and made movable for cleaning purposes.

I had made a few casual researches and comparisons, but I had seen pretty clearly the relative value of this Helio-type structure as against the rangy ground-floor type. I knew we would get twice the sunlight and twice the net working area in the Helio.

Well, Herbert Johnson threw his whole strength behind the scheme. We went to work in earnest. "Hib" was game. We

were both fortunate to find in the person of Benjamin Wiltscheck (educated at Penn as an architect) that rarity in the contracting business: a gentleman of the character and temperament to be faithful to the architect where an idea of this sort was at stake.

Reams of paper were covered with drawings. All these were needed to get a flower instead of a weed out of this rampant industrial system of ours. Gradually these drawings reached the full sizing of the complete anatomy of the entire structure all the way down to the wiring in place of the last rod laid as fiber in the 12,000 lb. concrete of the cantilevered floors. So after all here is the "flower" now to show what concentrated and coordinated effort (if subordinated to Architecture as a great Art) can mean even in a civilization such as ours. The sagacity of Herbert F. Johnson has given to the world this instance of an architect's creation in a field hitherto not invaded by (let us not hesitate to use the word) the great Art of Architecture.

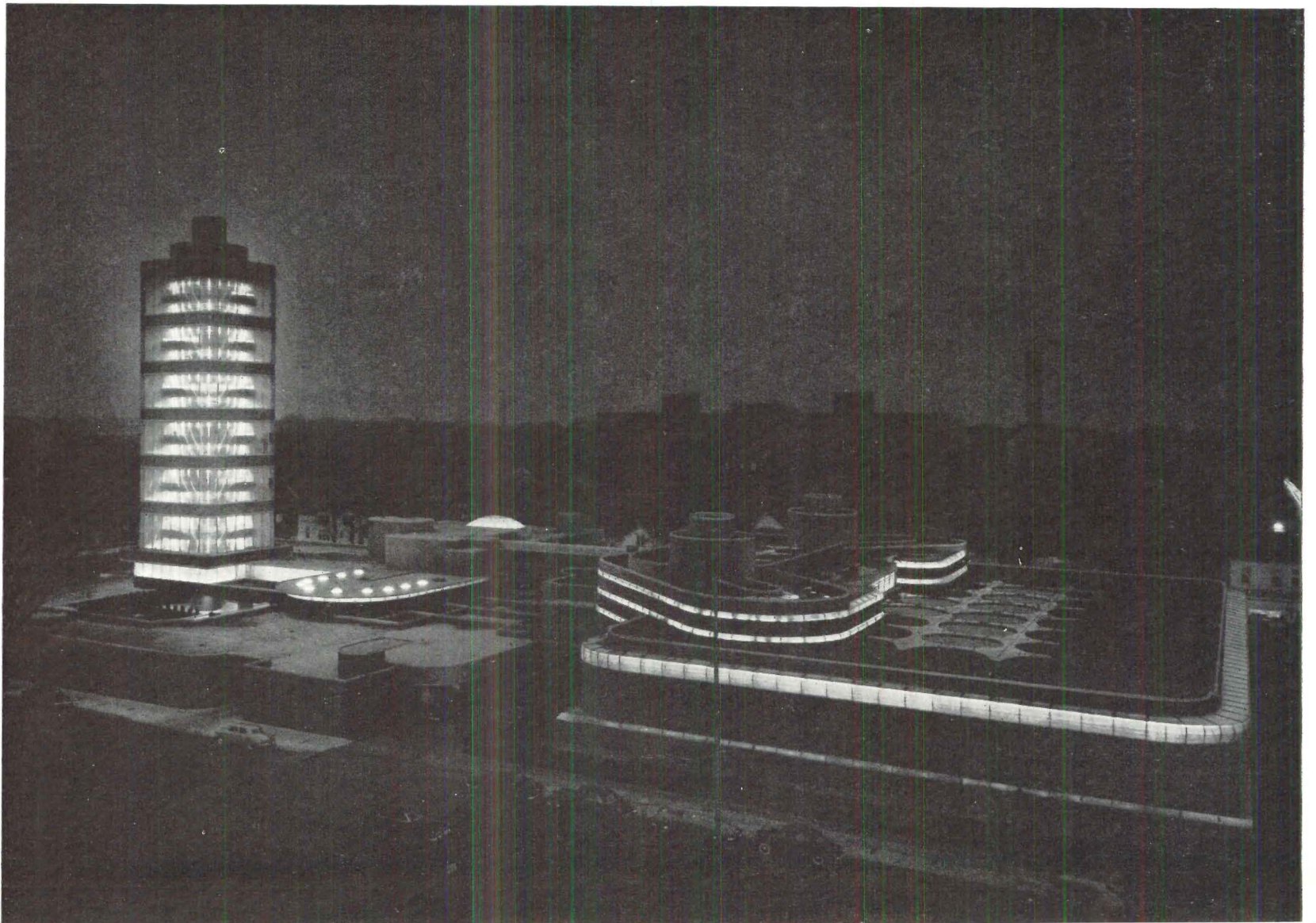

WITH NO SUPPORTS UNDER OUTER WALLS, CONCRETE ROOTED GLASS TOWER SEEMS ALMOST TO FLOAT IN AIR. ADJOINING OFFICES LINK



View of advertising reception room in new office building connecting research tower with administration building designed by FLLW in 1936. Glass dome spanning a 25 ft. diameter is made of concentric rings of glass tubing under a plastic shell. Curved doors set in glass tubing walls lead to private offices.



View of laboratory working space on square floor showing circular mezzanine floor above. Alternate mezzanine floors provide for easy installation of tall laboratory equipment. With access to all departments from central elevator and stair, all hall space is eliminated. Horizontal glass tubing admits diffused light to all working space.

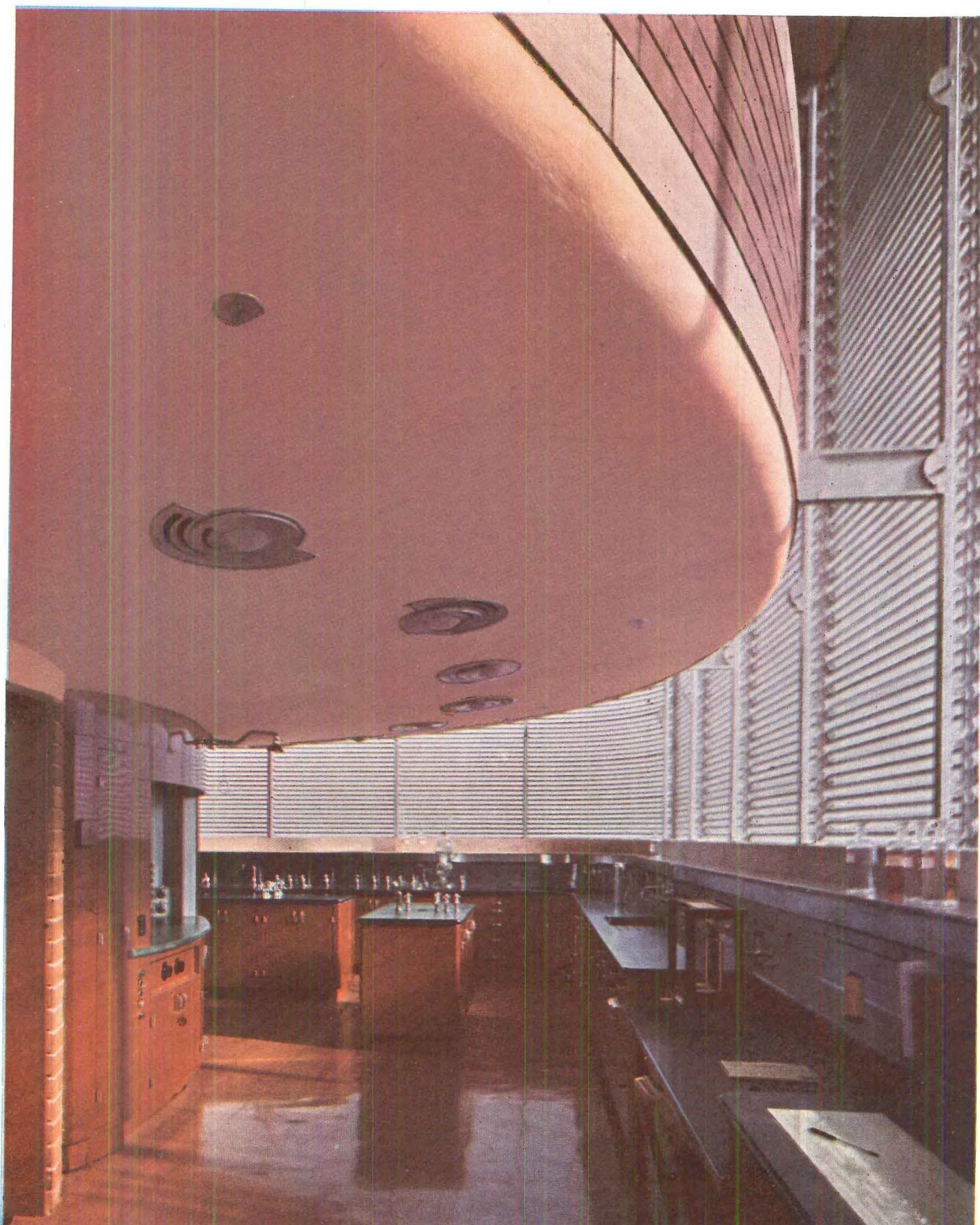

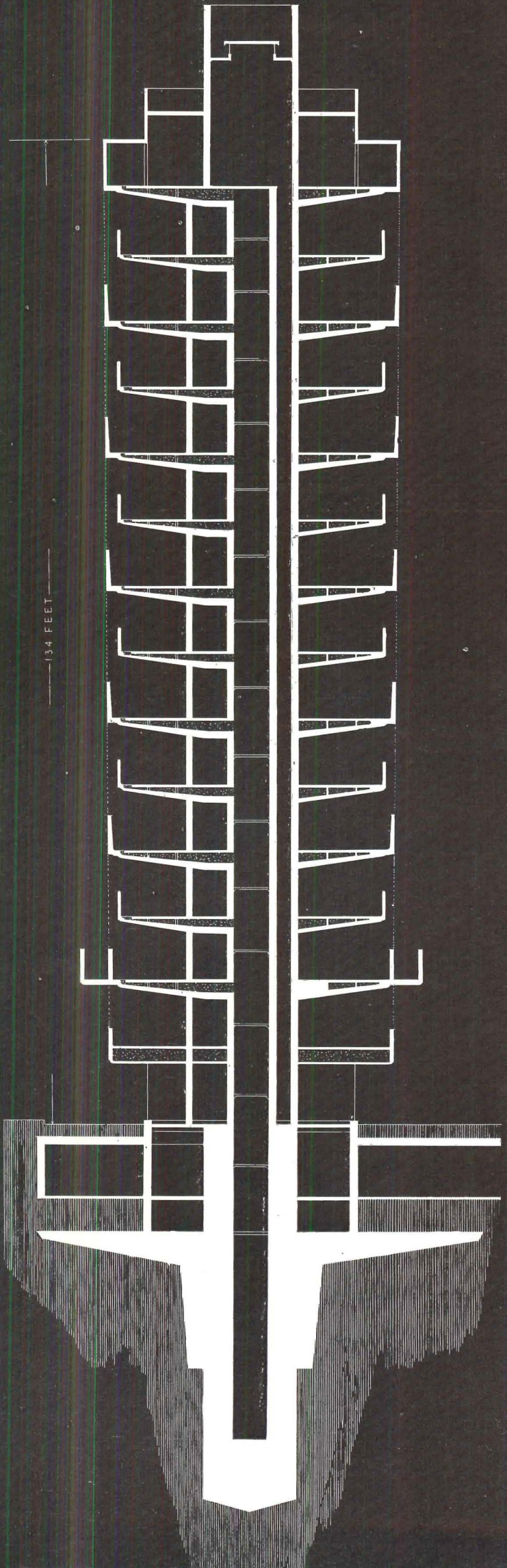
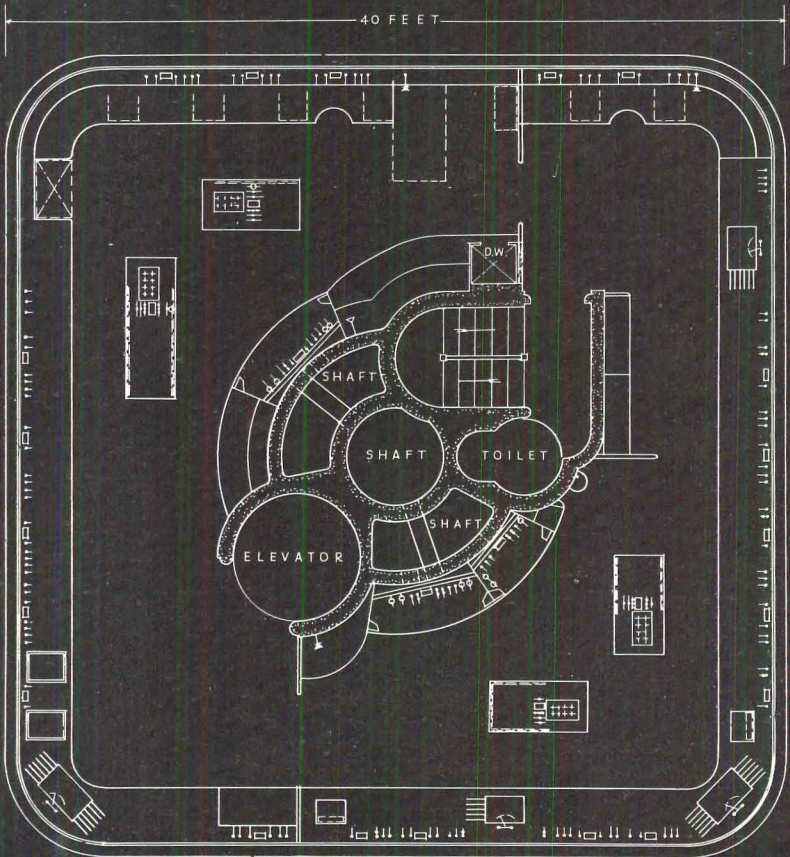
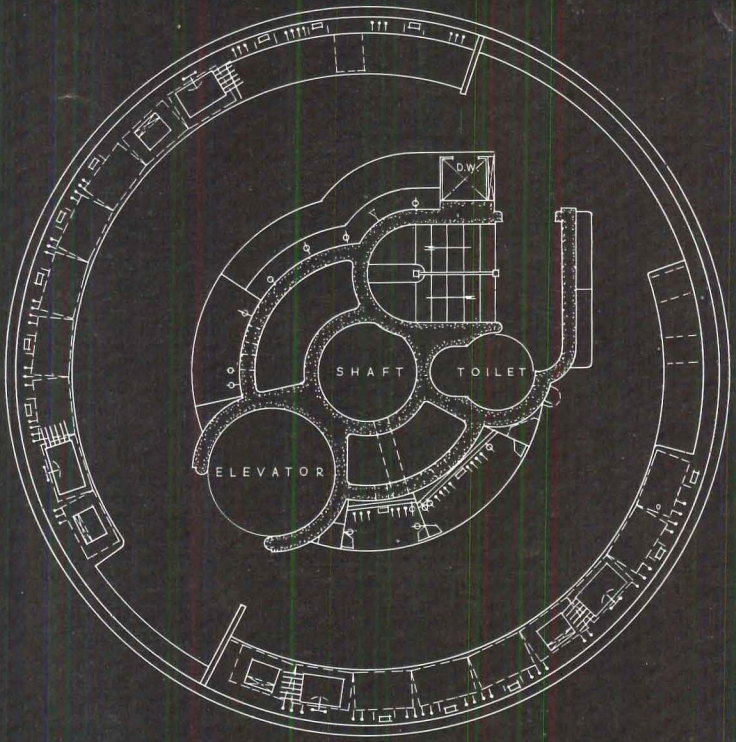

SCIENCE alone beyond furnishing tools in the toolbox can never lead us to a culture of our own. Without the practice of Architecture as the great art of environment — the basic art of Architecture is still sadly lacking in our midst. Architecture in this sense is still our national blind-spot. Not until we understand this will we ever arrive at sanity in building not to say the culture of Beauty. It is no exaggeration to say that we have had little or no organic character in our Democracy.

Without this way of building how can a true culture grow among us? We've, so far, cheated ourselves in Architecture. We came over in buckled shoes, knee breeches, lace around our wrists and around our necks, Colonials with a nostalgia for things left behind. So Democracy has remained largely our empty boast. There is striking resemblance between

our own situation and that of the people we fear most: the Russians. Although not in the same way, they are making the same mistakes we made.

Well, we have become famous as the nation of the Substitute. A nation wherein individual creation is good but only if it is good for any number of substitutes. Already we are more comfortable with mediocrity than any form of true originality. So our educational system now champions mediocrity. Only mediocrity is safe for the mediocre.

I often wonder why a true original has become so dangerous a thing? An idea is a sword. Any sword taken by the blade can destroy the one who thus mistakes it. Only when taken by the hilt and wielded as intended can it be used to achieve what culture alone can give — a great realization of the beauty of Life itself.

Here again by way of the author of the

Helio house (the hemicycle) comes the Helio laboratory. Both are sun-worshippers. Here in the laboratory is at least one industrial building we have salvaged from the vast industrial scrap heap — a structure proudly deficient in any fear at all. We know (we architects) that there is nothing on this earth so timid as a million dollars . . . unless it is more millions. There will not be many such voluntary contributions to our national culture for some time. Our big industrial boys come and they go and our lack of culture seems to go on forever.

Nevertheless in spite of such waste there remains the inner glimmer of light that will thrust by way of the individual true to himself and his light upon the daily life of frightened, war-threatened human beings. There is something deeper than we know in this dangerous, beautiful thing we so carelessly call Democracy.

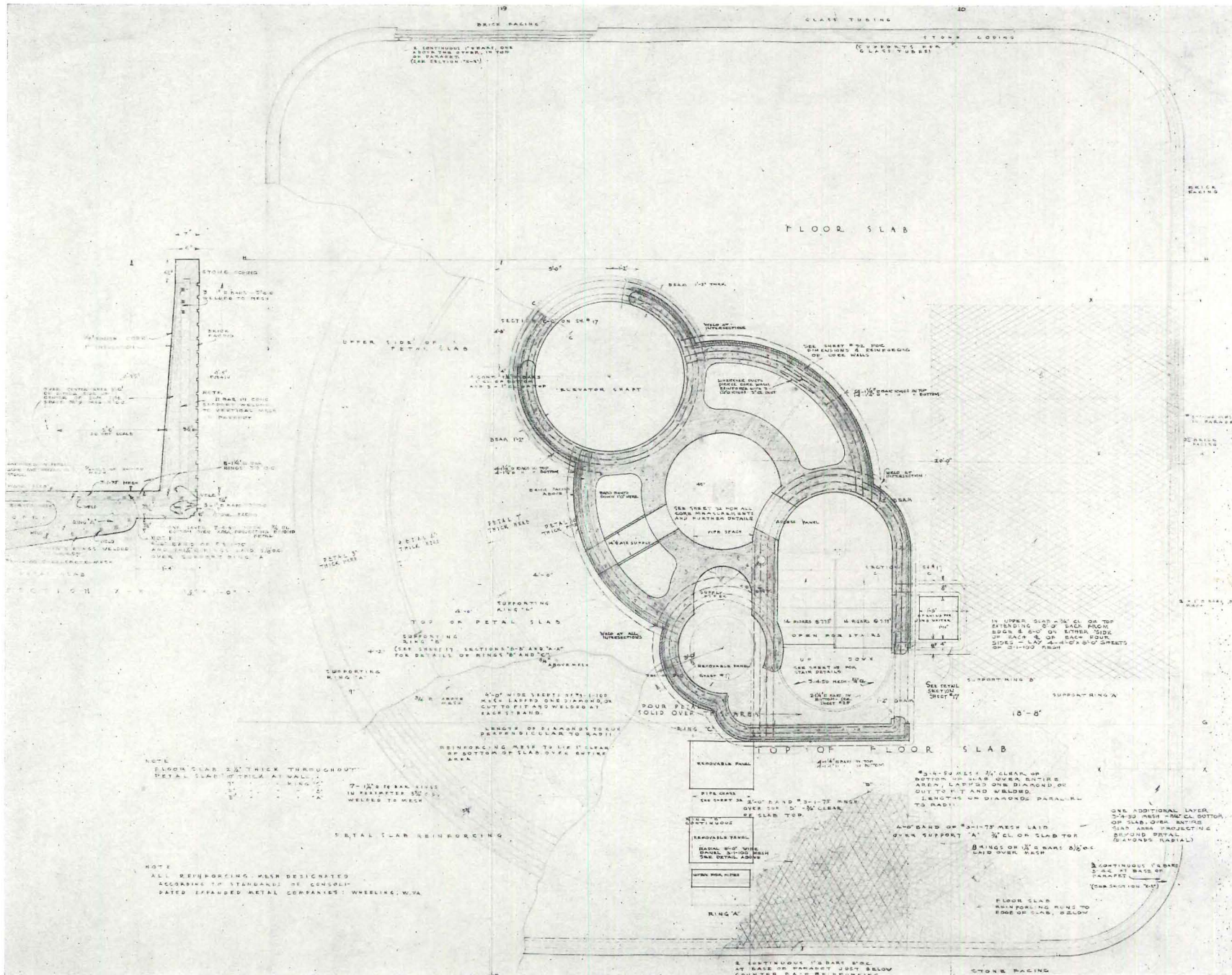

HOUSE FOR MR. AND MRS. LOWELL WALTER NEAR QUASQUETON, IOWA WIDELY OPENS MAIN LIVING AREA OR GARDEN ROOM

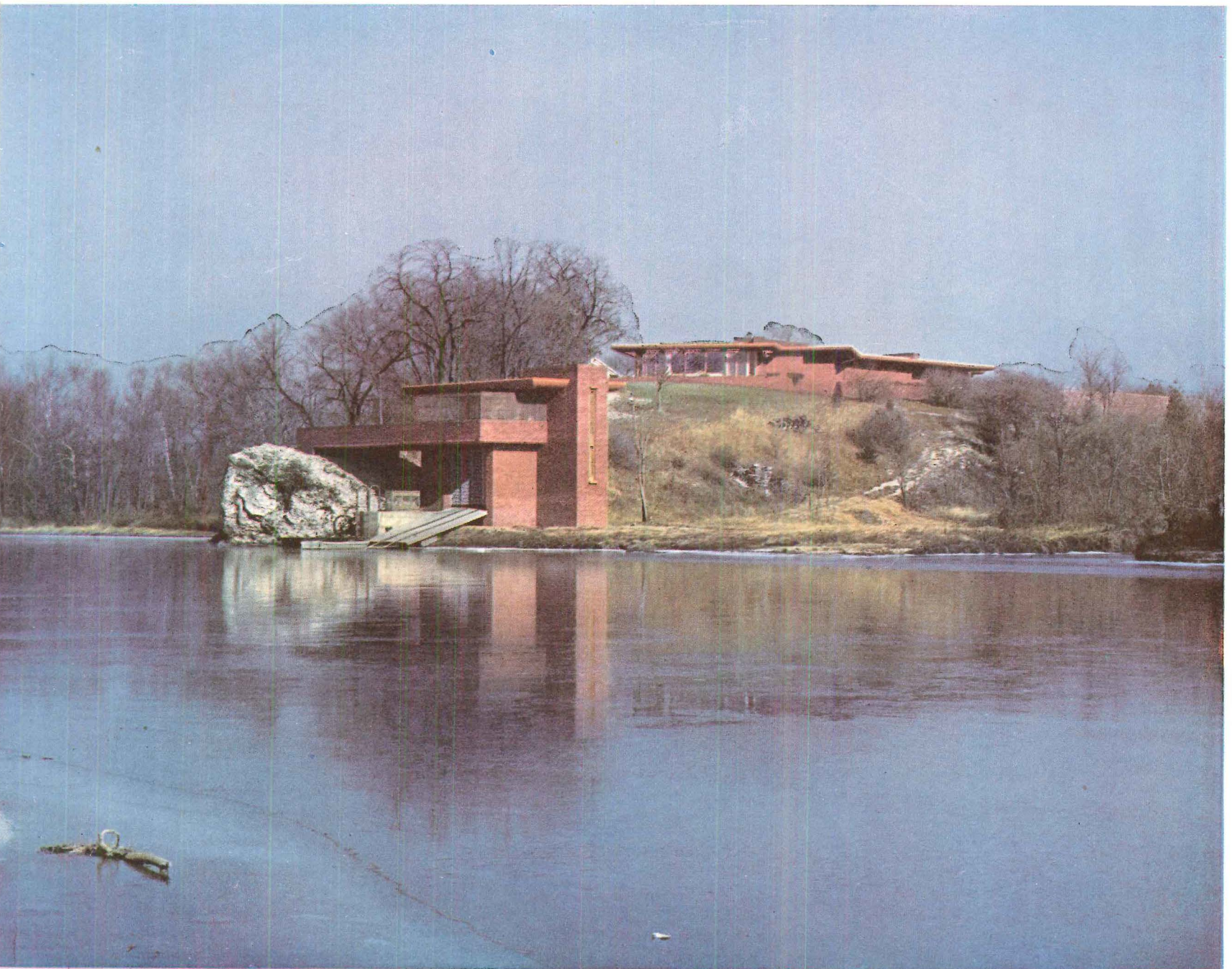
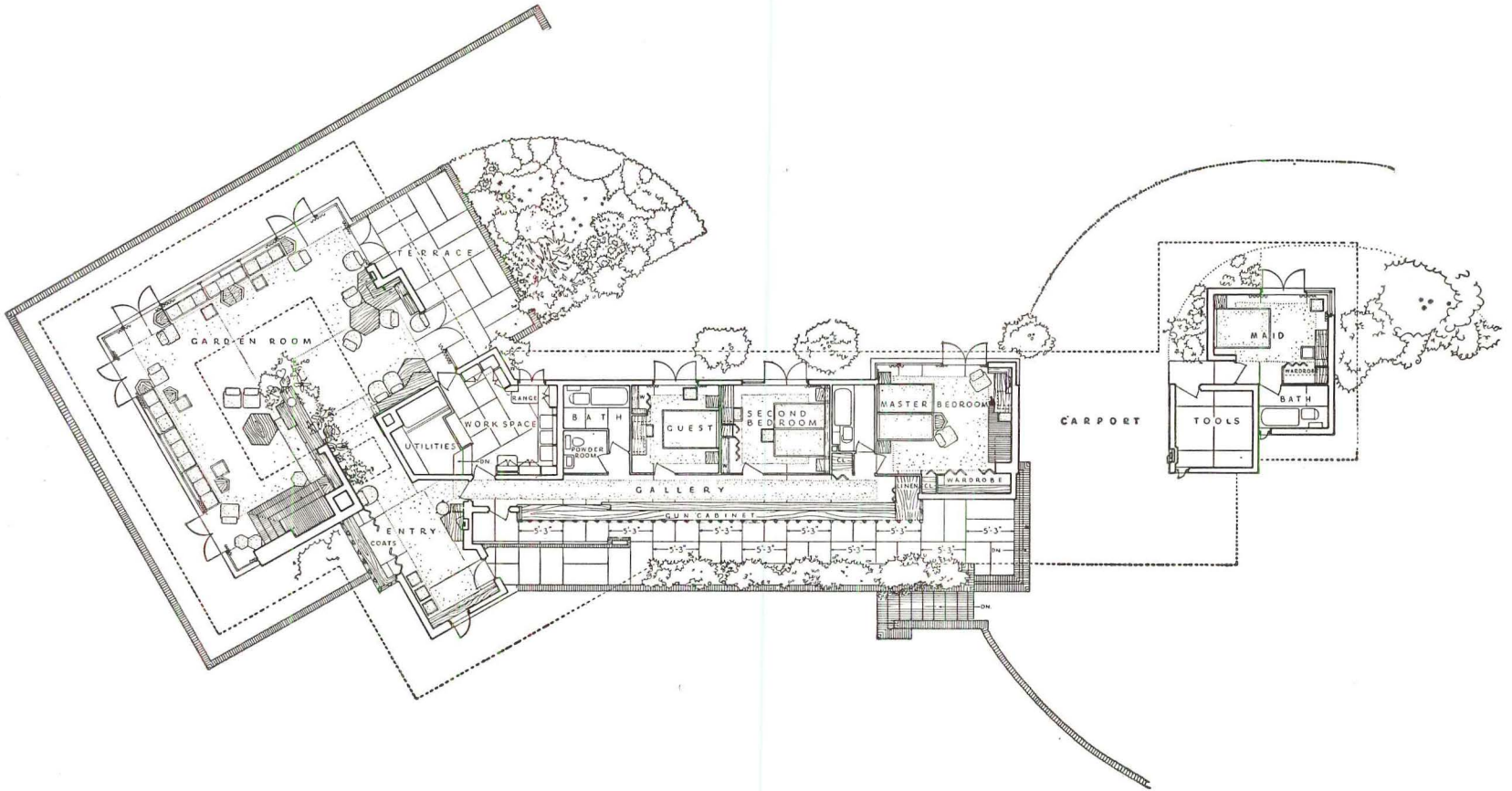

THE design of this house for Lowell Walter is built near the old Iowa town of Quasqueton. The design first appeared in the LADIES' HOME JOURNAL, somewhere about 1942. Mr. and Mrs. Walter saw it, liked it and it was expanded to meet their needs. Having this most beautiful of river front sites called "Cedar Rock," a great rocky promontory on the river, Mr. Walter wanted the river view tied into the scheme of the home. To build this highly specialized fabric far away from manifest civilization cost us all more than considerable labor pains and cost Mr. Walter considerable money. He doesn't regret the money nor do we regret the effort.

The house is situated on a gentle slope where the view to the river reveals both sides of a bend where the rapids beat against the big rock. The house is built of red brick, finely selected and well executed. Where wood the interior is native

walnut. Copper-corniced clerestories light the main living area of the garden room and bedrooms. The turned-up concrete slab roof is carried on slender steel supports. The entire roof is to be covered with peat moss and black earth. Grass and ground cover will be grown there, a pleasant grass terrace when seen from the hill above. The house itself is set in a frame of Portulaca blooming around the glass.

NOTE: In this river-sited house, Wright uses more glass than is usual in his residential work. It is almost as if he had taken the proposition of the glass house about which we have heard so much lately and turned in one more example of his lifelong endeavor to show how the sense of space can be introduced without loss of the sense of shelter—an example made very plain for those who may have missed the point before.

Basis of the house is the square glass garden room, with abundant planting used on the inside. Three walls of this room are open in an indefinite extension of space to the hills and the river, but with the fourth, space is limited, held in by the sheltering sense of the brick hearth. But Wright is not content merely to demolish his walls; yet another means in his lifelong assault on the limiting effect of the structural shell makes an appearance. Here the concrete roof slab itself is broken by double clerestories and by square skylights, and this latter cutting of the slab is repeated on the deep roof overhangs. The turned-up slab roof which helps to marry this house to its ground must surely be one of the most beautiful Wright has done; yet its grace must also remind us that long ago Wright pointed out that another effect of such overhangs is to provide the interior with softened light.



TURNED UP CONCRETE SLAB ROOF OVER STEEL SUPPORTS. VIEW OF ENTRY SIDE SHOWS SERVANTS QUARTERS, CARPORT RIGHT

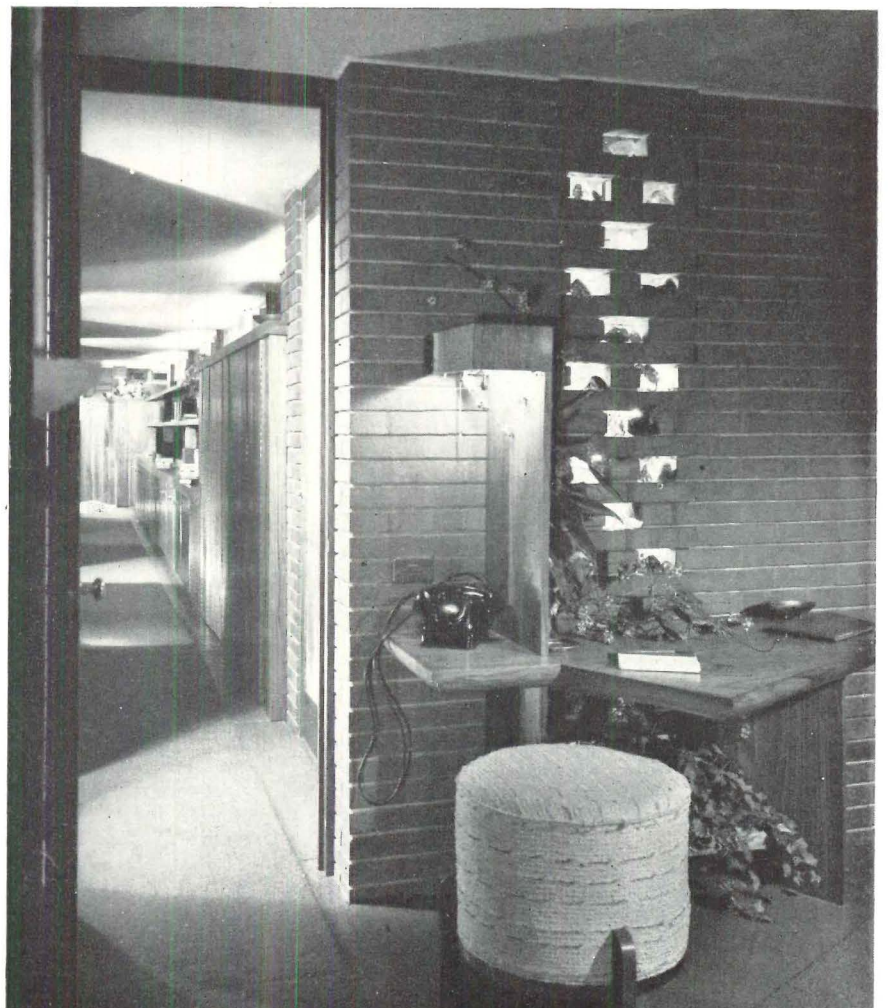
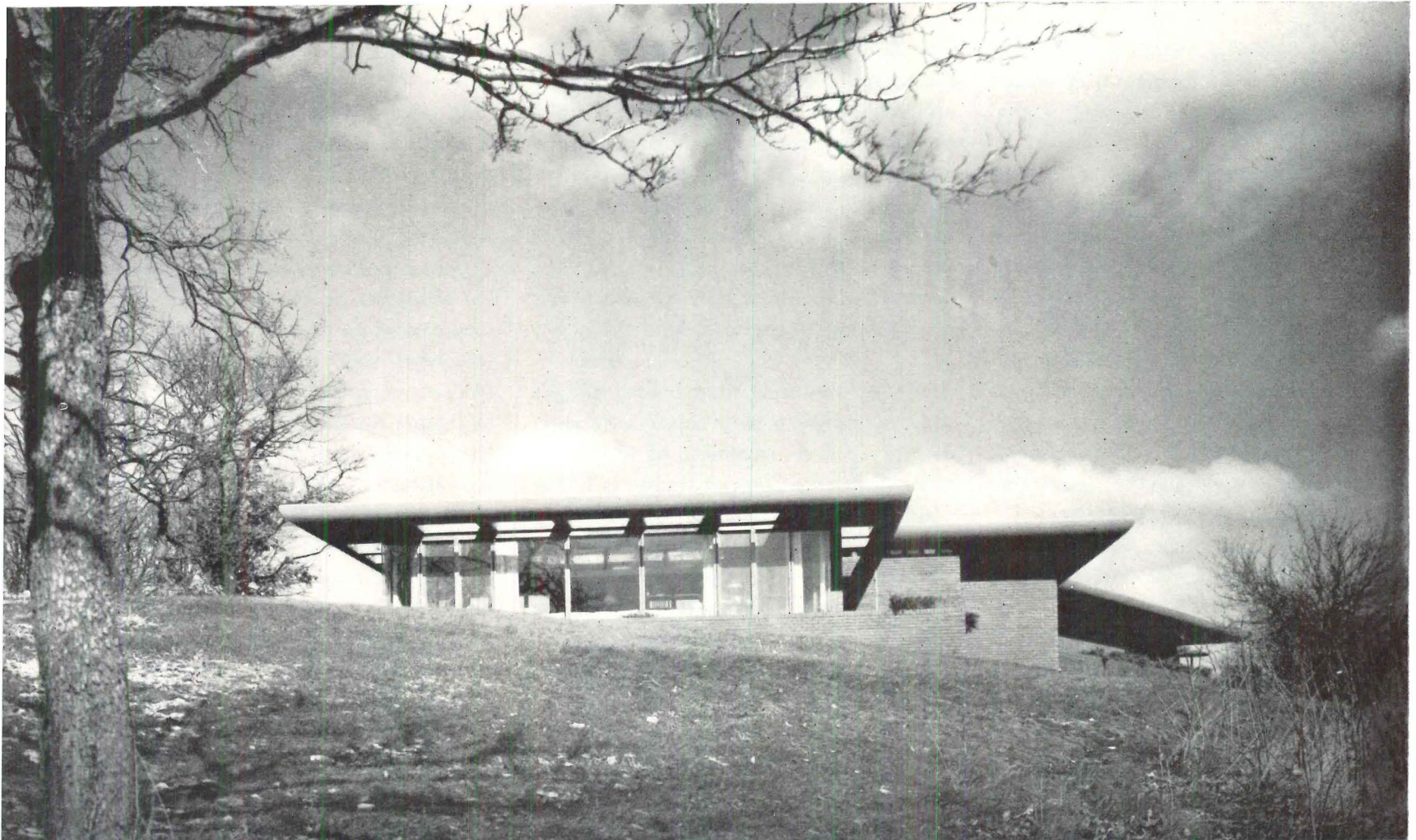

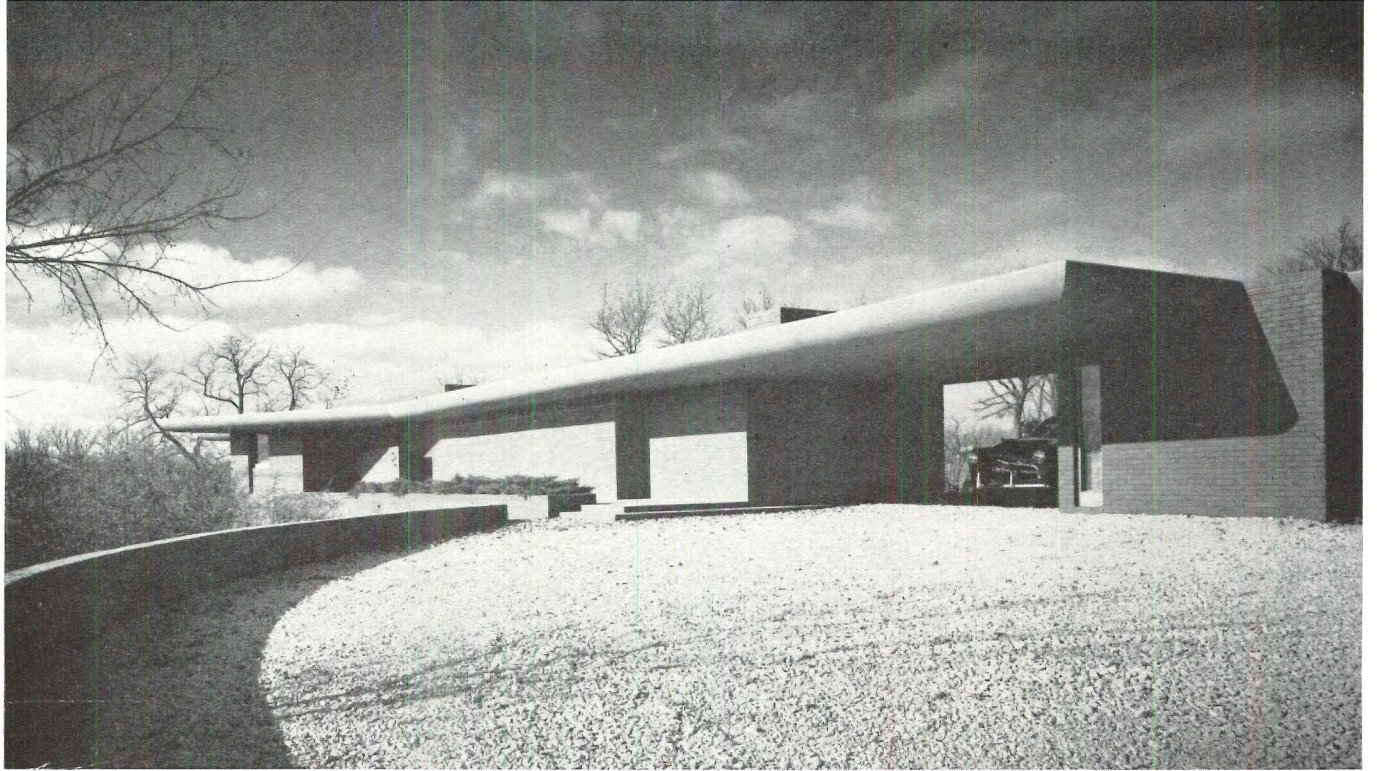

BENJAMIN ADELMAN HOUSE IN MILWAUKEE SHOWS WHAT SKILLFUL HANDLING CAN MAKE OF STANDARD CONCRETE BLOCK. LONG

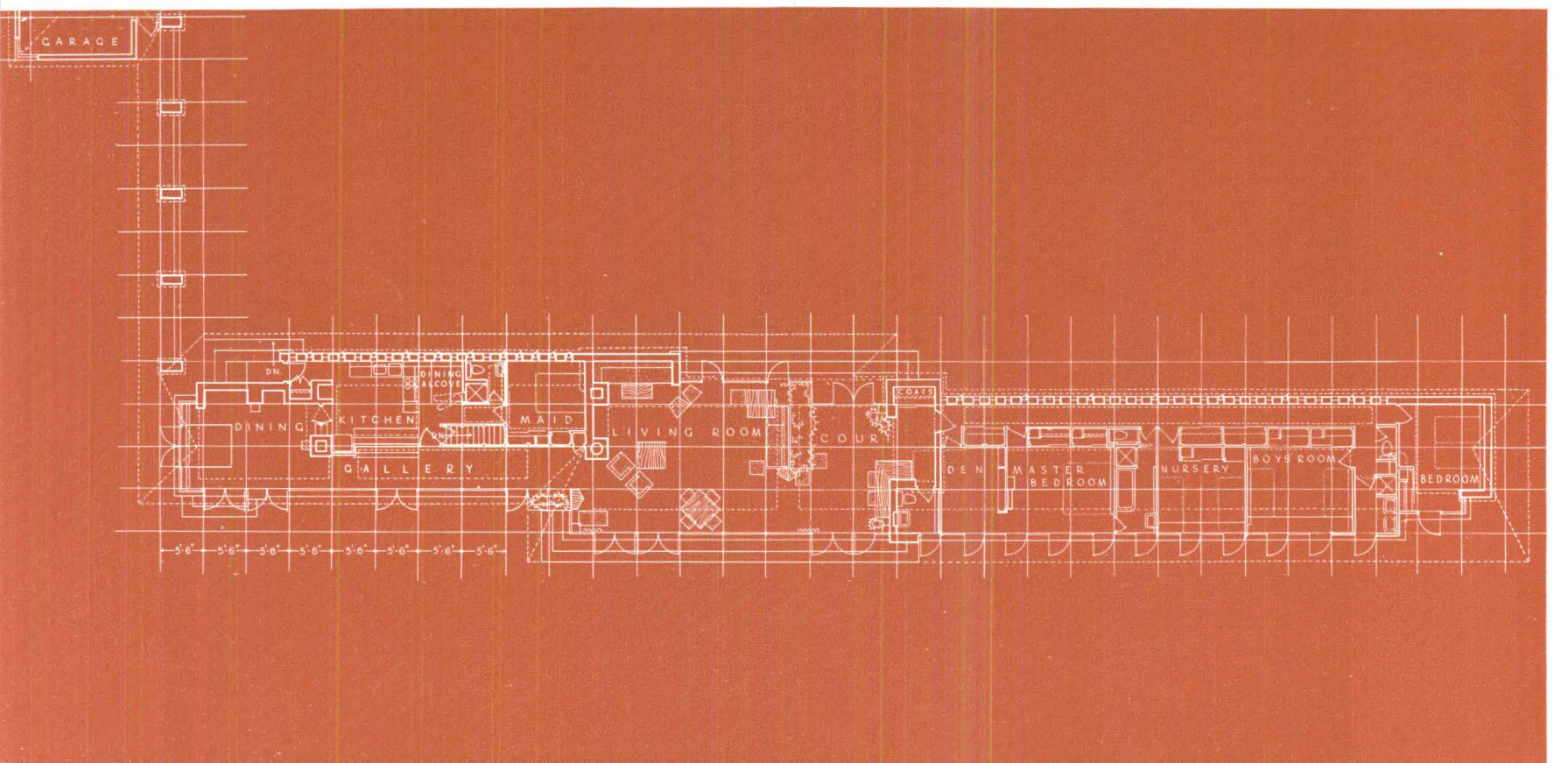

THIS house exploits its narrow plot of land. Planned for a long, narrow lot (800 x 138 ft.), this building is a simple L-shape block mass, roofed with cedar shakes. All rooms are in line along the length of the building. A car park and pergola form the flange of the L. The dwelling is so set at an angle that views from the central living room are as generous as if the narrow lot were an estate. The complete woodwork interior is beautifully done and the effect of the whole house is one of dignity outside, elegance within and repose for the young couple who own it.

NOTE: Here is evidence that the hand which developed the "nature of materials" at the beginning of the century has gained rather than lost its skill. Here also is evidence that sensitivity to form and texture

need not be confined to such "natural" materials as wood and stone, but can bring exceeding grace to a synthetic material often crudely used.

Buff color is integral in these rough textured concrete blocks. Blocks were stepped out $\frac{3}{4}$ in. every two courses (16 in.), providing not only a protected horizontal joint but a delicately tapering line on both exterior and interior. Vertical joints were drawn flush by filling with a waterproof material of the same color and texture as the blocks.

Students of the FLLW detailing will note his familiar board-and-batten joint (rationalists might point out that a joint like this allows for the shrinkage inherent in wood; estheticians might remark that it is like a celebration of the fact that boards are boards and must be joined). This beautiful wood joinery is carried from the out-

side (as seen in the soffit, L) to the interior woodwork. Note also how rafters are only partly exposed, giving a sense of structure without the heaviness of the full rafter and also providing for roof insulation.

While the usual ceiling is removed to lift the vertical space dimension to the rafter line, here the architect nevertheless uses his familiar decking around the perimeter to hold his interior to human scale and exploits the decking to provide built-in up-and-down lighting. Glass introduced above normal partition heights between work and living areas is another means by which space and light are emphasized and used to demolish the box.

Horizontal unit from which this plan was developed is a 5 ft. 6 in. square. Vertically the module is the ordinary 8 in. concrete block.



VIEW FROM MAIN LIVING AREA THROUGH GLASS WALLED GALLERY LEADING TO DINING ROOM. WORK CENTER BACK OF FIREPLACE



YOU HAVE BEEN CALLED A "ROMANTICIST" IN ARCHITECTURE. SINCE YOU WERE THE FIRST (1903) TO POINT OUT SOME OF THE REALITIES OF OUR MACHINE CIVILIZATION, HOW DO YOU ACCOUNT FOR THIS CHARGE?

Well—there stands Romeo and Juliet, the wooden windmill triumphant over steel. A structure built like a barrel, there it's been standing on top of its hill for 46 years. All the doubting Thomases who came regularly to their doors after every big storm to see if the windmill was wrecked have themselves all disappeared beneath the sod. Romantic?

But the name ("Romeo and Juliet") must have introduced me to the architectural world as a Romanticist. I am a Romanticist, but not of the favorite variety. I've been the kind of romanticist in search of Reality—Reality being new in Architecture and in Being—for me the fascinating quest of all quests. Eventually it will become the greatest of all paths of human discovery.

No, you cannot see the Machine in Romeo and Juliet but it is there. The Machine can be nowhere a Creator except as it may be a good tool in the creative artist's tool box. It is only when you try to make a living thing of the Machine itself that you begin to betray your human birthright. The Machine can do great work—yes—but only when well in hand of one who does not overestimate its resources, one who knows how to put it to suitable work for the human being.

The proper use of the Machine should be to make life more beautiful, more livable. No, not necessarily easier and quicker just to feed this American voracity which we call speed. If speed and destruction plus sanitation are to be the function of machinery among us, the machine will destroy us and its present idolatry will eventually defeat our attempt at a culture.

These buildings, this Architecture I

myself have created, is simply a lifelong, fully conscious, unremitting effort to render the Machine—this tool of modern times—so useful that a great indigenous culture we could honestly call American might occur. A living expression of the greatness of the human spirit of our nation might be ours. So what quality you perceive in these buildings must be the reflection of a truly religious endeavor to make Beauty of environment come alive again for our own people; to make them aware of the richness of a life they now almost wholly miss. This innate richness of life can be theirs only when they learn how to command, restrain and use the machine properly, that is to say as a mere tool instead of falling into the worship of it as a money maker. The Machine has yet nowhere given to America the flower of indigenous Culture. The Machine has so far produced for us only the weeds of a Civilization.

SLOT WINDOWS ON ENTRANCE SIDE OF HOUSE LIGHT LONG CORRIDOR. RHYTHM OF FRAMING BREAKS TUNNEL OF HALL

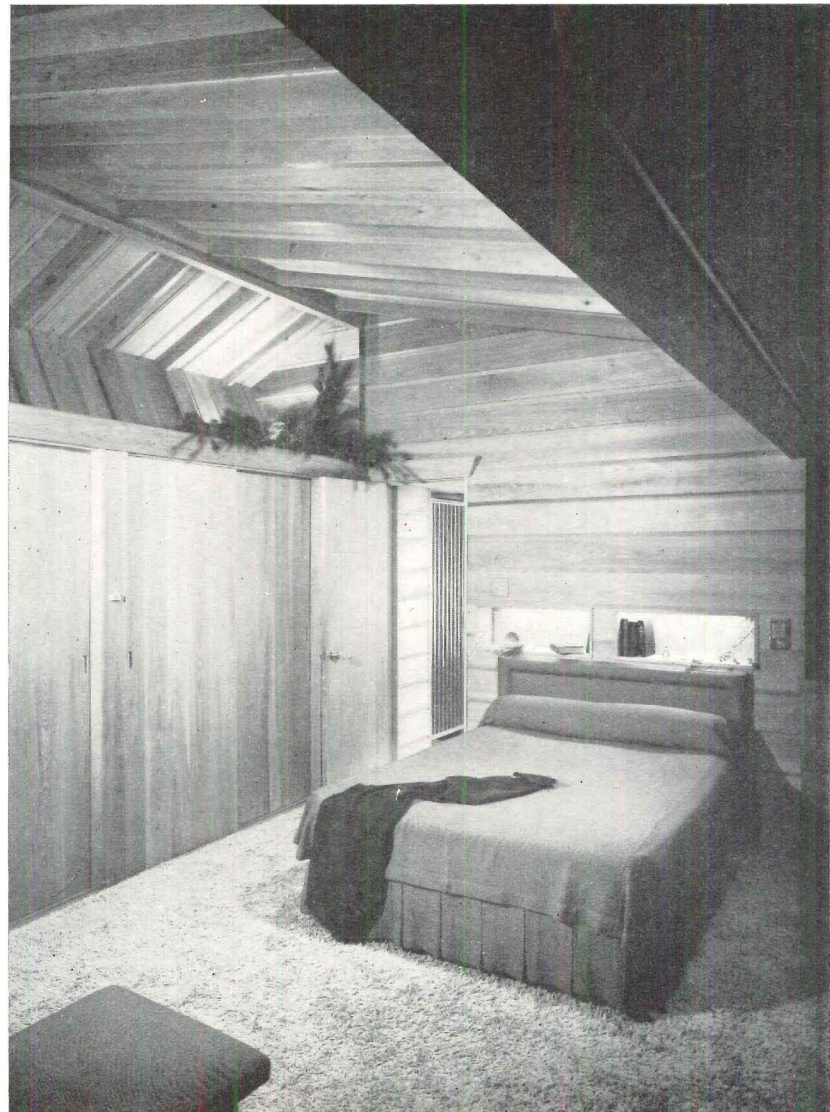
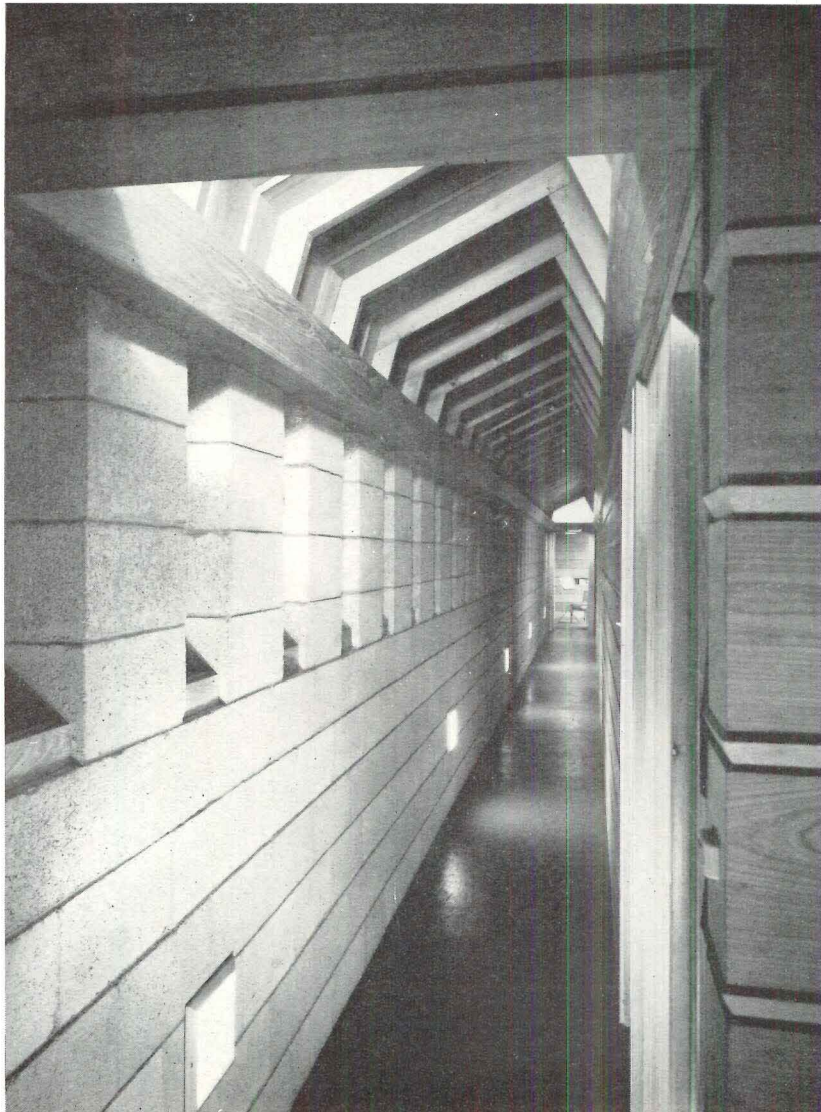

HERBERT JACOBS HOUSE II IN COUNTRYSIDE NEAR MADISON, WIS. TWO-STORY SOLAR HEMICYCLE BANKED AGAINST WIND.

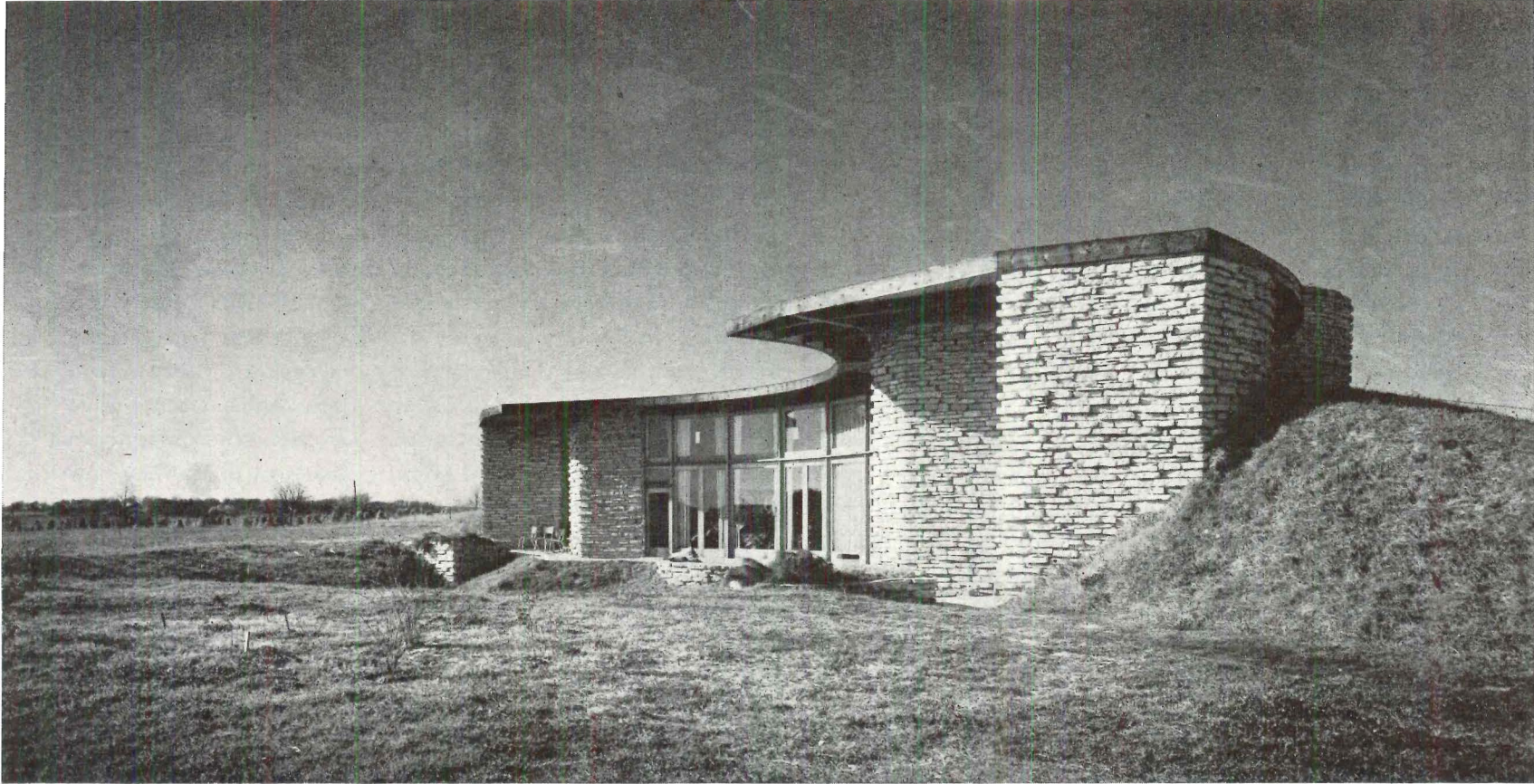

THIS solar hemicycle is one of a growing family of houses now known as Usonian. They are growing up all over the country—overlooking hill crowns or banked against hill slopes.

A sun-receiving, wind-checking form of earth-protected building, here is a house getting comfort and protection out of the circumstances of its location. Sun-heat is

incorporate; protection from severe cold is a natural feature of the first floor area by way of the berm type earth banks around behind it.

The surrounding planting is yet to be done. It will include a polychromatic ground cover for the banks of the sunken garden and a large mass of evergreens standing to the left of the hemicycle.

The sunken garden in front of the hemicycle partly protects exposed glass surfaces from winds and affords a sheltered space in which children will play.

The effect of the whole house is unitary — a one-room affair — the interior space subdivided as may be desired. Here in one room is the whole affair of good living — the warmth and invitation of a true home.

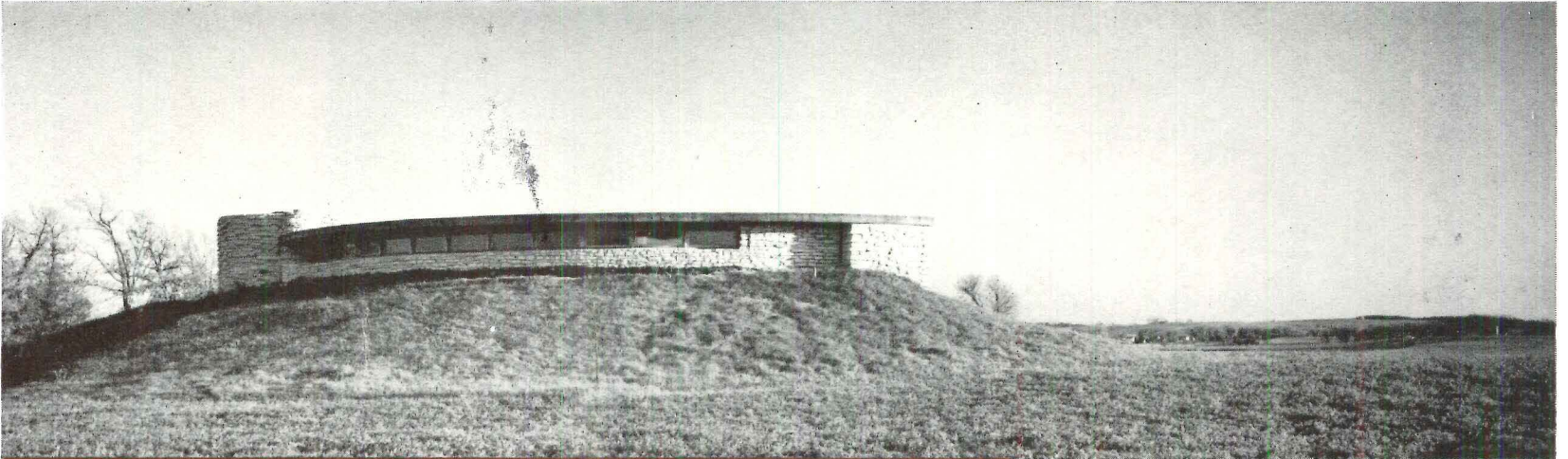

NOTE: Here Wright demolishes the box which the "solar house" has come to mean in contemporary building by curving his basic form as a hemicycle. The hemicycle form can also, of course, be said to represent the complete logic of building to trap the sun; by curving the two sides of his building, Wright takes full advantage of the elliptical solar path.

Note how simply this mature plan handles basic principles apparent in Wright's earliest houses: demolition of interior partitions; grouping of utilitarian features so as to allow space to be uninterrupted so far as possible (circular stair, plumbing and heating channel). Here the basic horizontal unit from which the building plan is developed is a 6° sector. Non-architectural readers may want to study the plan to see how this basic unit or module is used to dimension all parts of the building (two units equal width of window, two units equal diameter of the circular fireplace, four units are allotted to utility core, etc.). It is interesting to reflect that the architect who has wrested the greatest amount of freedom from the basic limitations of structure (from the building as a box) should nevertheless hold, with such gentle care, to his self-imposed discipline of space: the unit system (square, rectangle, honeycomb hexagon, circle) as a basic measure insuring the harmonious relation of each part to the whole.



BEDROOMS OFF MEZZANINE.

WHY HAS IT BEEN SO HARD FOR OTHER ARCHITECTS TO UNDERSTAND THE INNER NATURE OF YOUR METHODS OF BUILDING?

When the structure of an idea has once been frozen into an "effect" it can be too easily transferred. Now there can be nothing frozen or static about either the methods or effects of Organic-architecture. All must be the spontaneous reaction of the creative mind to a specific problem in the nature of materials. A new esthetic is looking for its principles in Nature with a capital N.

You see, by way of concentrated thought, the idea is likely to spring into life all at once and be completed eventually with the unity of a living organism. In architecture each new plan will have its own grammar and law of growth. An inner module of space measured by a unit system in plan as well as elevation makes

each detail proportionate in any plan we make, each part an inevitable and well-proportioned portion of the whole. Thus we arrive at entity and "atmosphere". Only entity lives.

This inner thing is what disciples (or imitators) have not fully grasped. How could they? Here is no secret of an "American Style" — in which any architect might find a "safe" grammar to carry from one job to the next. What most of the now world-wide followers of the organic effects fail to understand is that there is no possible transfer of the same grammar from one genuine building to the other. The law of growth for the Johnson Helio-lab, for instance, is as different from that of Taliesin West, say, as the oak tree differs from the cactus. But both are alike in their inner concept and con-

sistency of grammar. Each is true to itself.

What then can I tell contemporary architects except to seek that inner freedom — a sense of being — which will enable each to grasp for himself the freedom of his own idea? He will then find that the inner nature of his problem always carries right there, within itself, its own solution.

Because of this inner sureness of "ways and means" in architecture as a part of myself I am often termed "arrogant." Now I submit that what seems "arrogance" is only a surface irritation caused by the hypocritical humility of a profession now become no higher than a labor union, by self-seeking "publicity" and by the natural enemies of all integrity bent on tearing our culture down. I would be glad to drop it, and do so occasionally.

VIEW LOOKING FROM SUNKEN GARDEN IN TOWARD THE HOUSE AT EVENING SHOWS THE RANGE OF OCCUPATION OF THE LONG ROOM



JOHN PEW HOUSE IN MADISON, WIS. SHOWS WRIGHT CAN ACHIEVE FREEDOM FROM THE BOX WITHIN LIMITS OF RELATIVELY SMALL



THIS is probably the only house in Madison, Wis., that recognizes beautiful Lake Mendota: my boyhood lake. See here a house actually built by the Taliesin Fellowship. The Frank Lloyd Wright Foundation took the contract for this building (virtually because no one else would) and promptly built it. We are more and more builders as well as architects and intend to be builders more and more. The Pews have found happy sanctuary in their home and use it in the home like way intended.

This two-story wood and stone house is built of lapped cypress boards inside and out. Local stone is laid up the Taliesin way now seen all over these parts and now pretty much all over the United States of America.

NOTE: This relatively small house shows that Wright's great gift for plastic handling of space and structure is by no means confined to costly buildings like the famed Falling Water House. See here

how simply FLLW has exploded the box-like limits of building: the two floors of the dwelling are pulled apart to permit light and space to enter freely; with the house lifted by massive stonework at one end of its hilly site, space literally flows uninterrupted beneath the whole structure. Because of its economy in space and cost, this house may show more clearly than any published in this issue the fundamental simplicity underlying this great architect's residential work. This simplifi-

cation is now so widely established in contemporary design that it is easy to forget what the American house was like when the young architect in Oak Park began his practice. This great simplicity developed as FLLW gradually discarded every building encumbrance: the basement, the attic, radiators, light fixtures, paint, interior trim, gutters, downspouts, garage — everything that stood between the householder and the fullest sense of space, light and freedom.

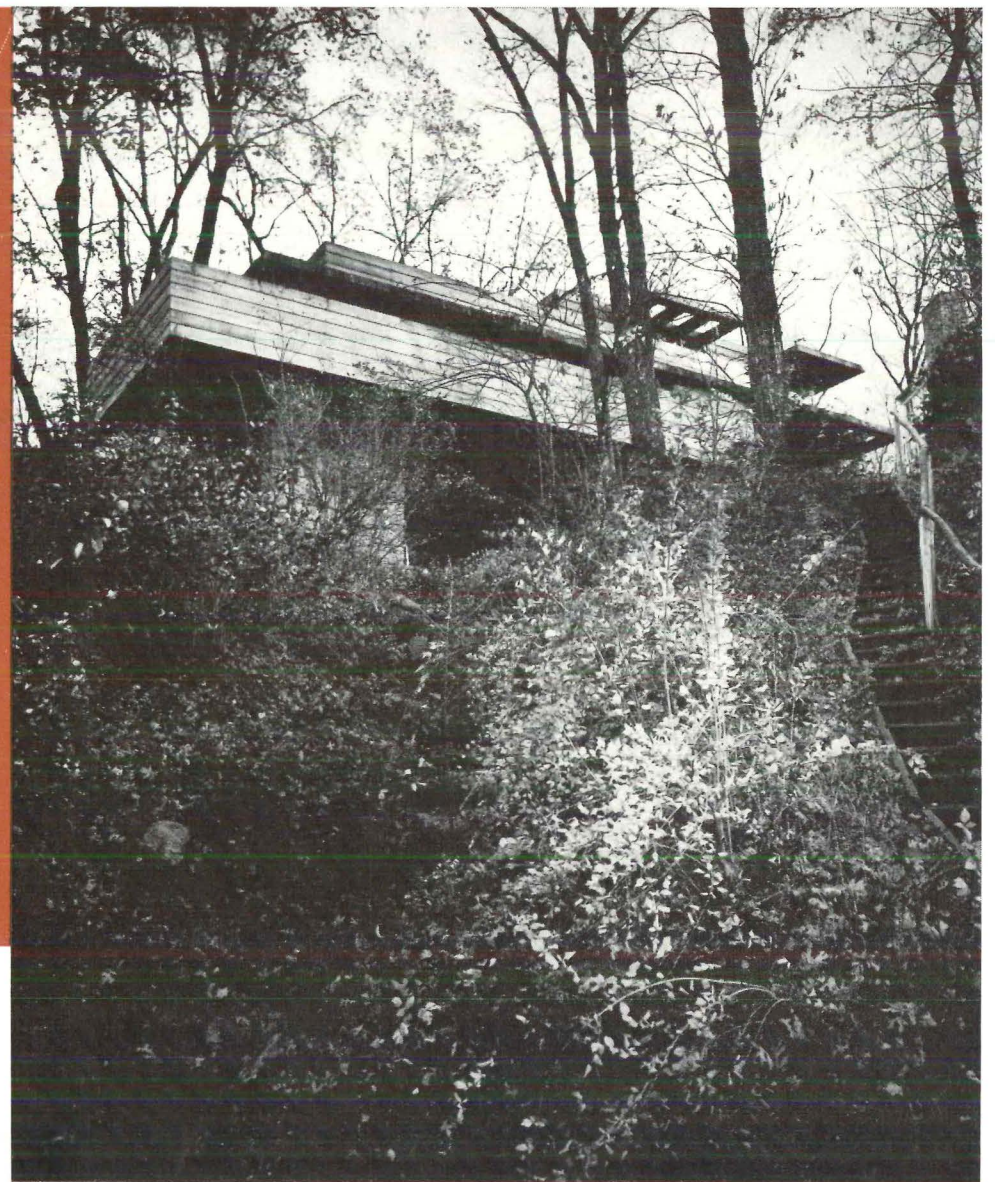
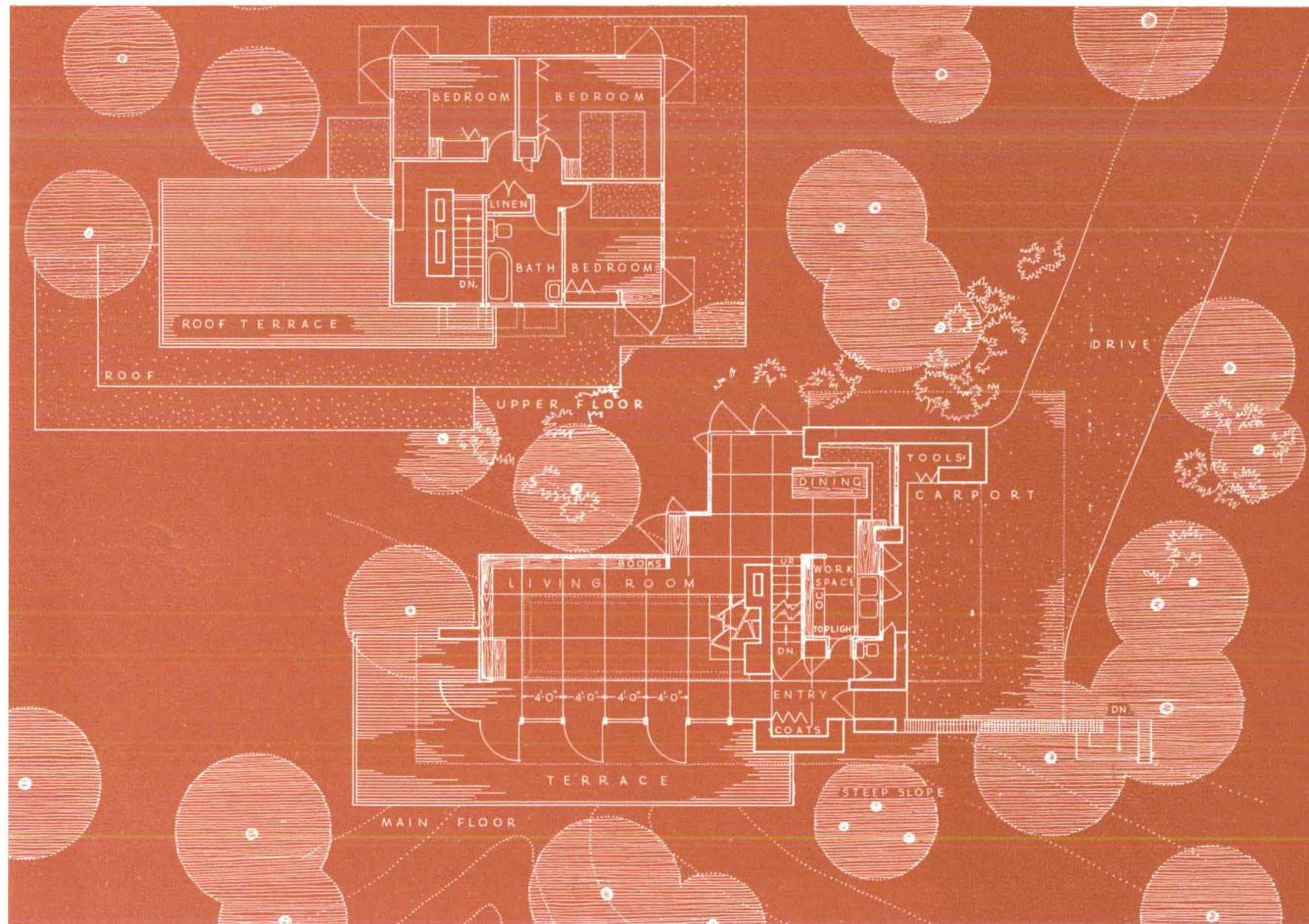

HOUSE: SPACE FLOWS UNINTERRUPTED BELOW WITH TWO-STORY HOUSE LIFTED BY STONE COLUMN AT ONE END OF HILLY SITE



BUILT OF CYPRESS

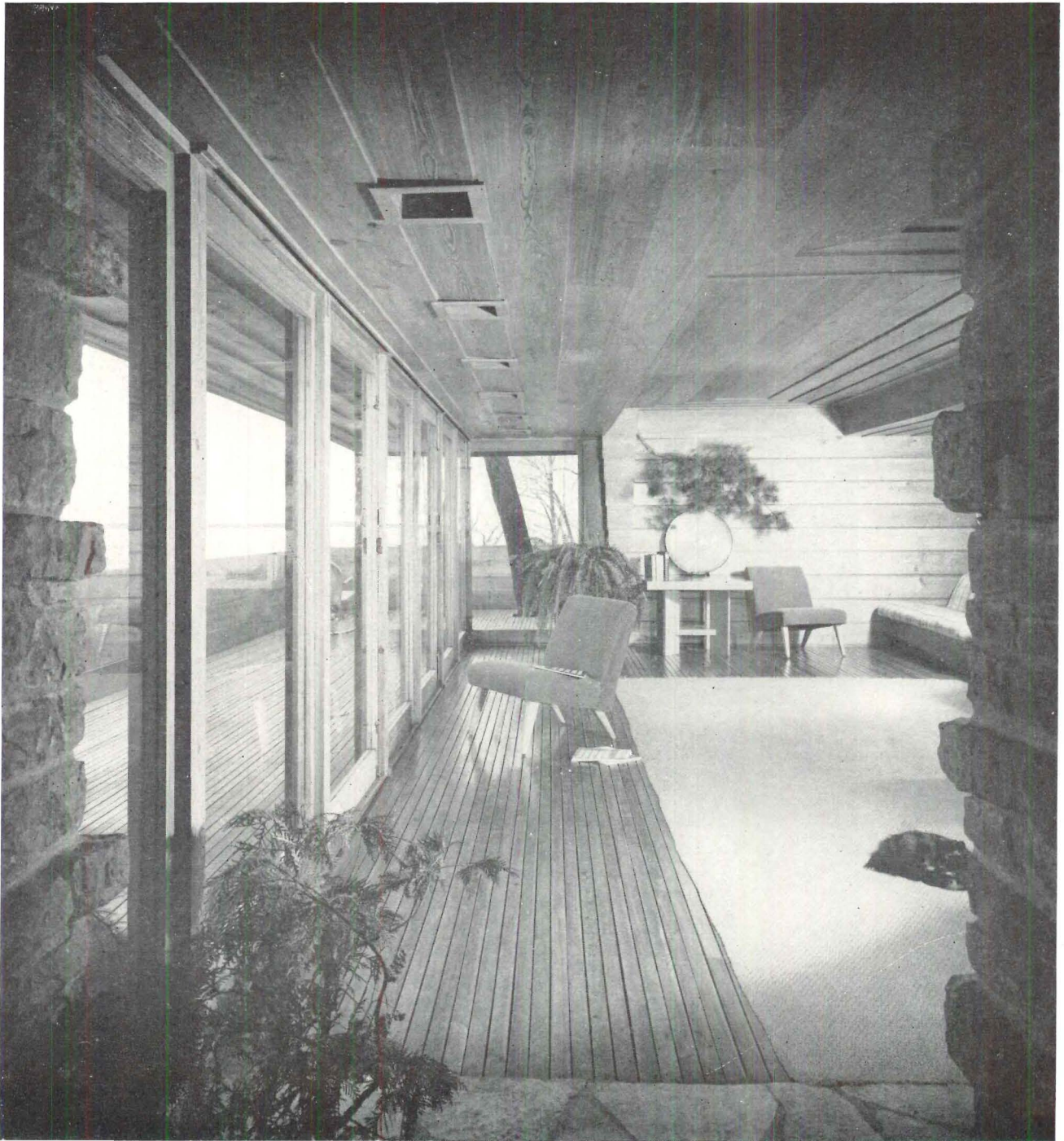

WHAT EFFECT DO YOU THINK THE "INTERNATIONAL STYLE" HAS HAD ON AMERICAN ARCHITECTURE?

The internationalists say that they have an architecture of "restraint." What have they to restrain? All they have done seems to me just "strained."

If the motive of their work is examined for truth, it will seem to mean elimination of the individual — per se — as such. His God-given qualities as a creative being are left out in order to mass produce something fit only for mass consumption.

The great Art of Architecture is thus

made a mere cliché; a pattern that could be cut from cardboard with a pair of scissors by the novice. Again they have robbed Organic-architecture, the natural architecture of a Democracy, of all that it could give to an indigenous culture. The Internationalist (so called) seems to care little about freedom, freedom not for personality merely but for the individuality without which Democracy dies. Our little provincials in Architecture are quite eager to give our own American heritage

away. So it seems. They do not know even now that they would give our American heritage away if they could. The philosophy of an Organic-architecture is new to them. A grammar they are unable to read as the center line of our Democratic faith which really it is. This philosophy is old but is a new thing under the sun in this era. Organic architecture is the center line of Democratic philosophy not only where buildings are concerned but in the politics of government as well.

BOARD INSIDE AND OUT AND OF LOCAL STONE, HOUSE HAS WIDE TERRACES ON BOTH FLOORS WIDELY OPENED TO LAKE VIEW

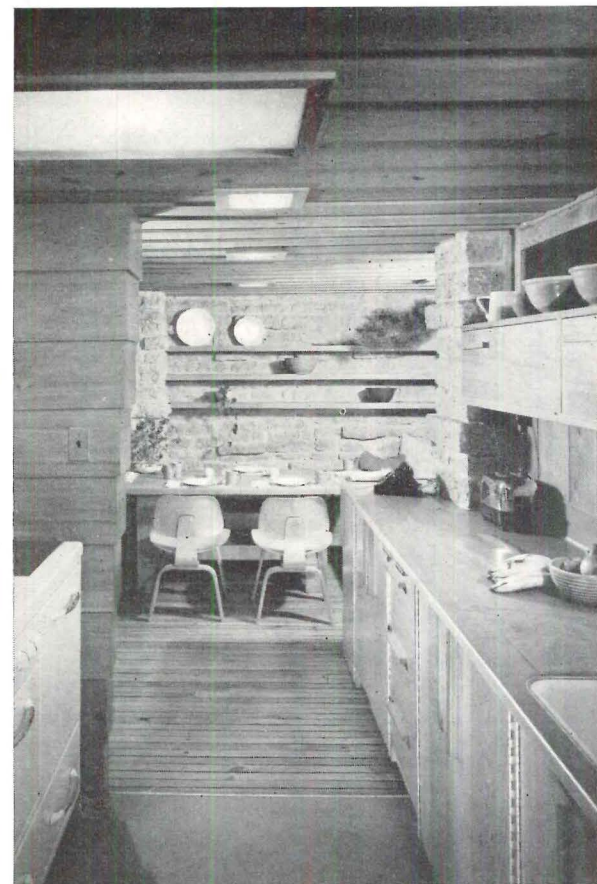
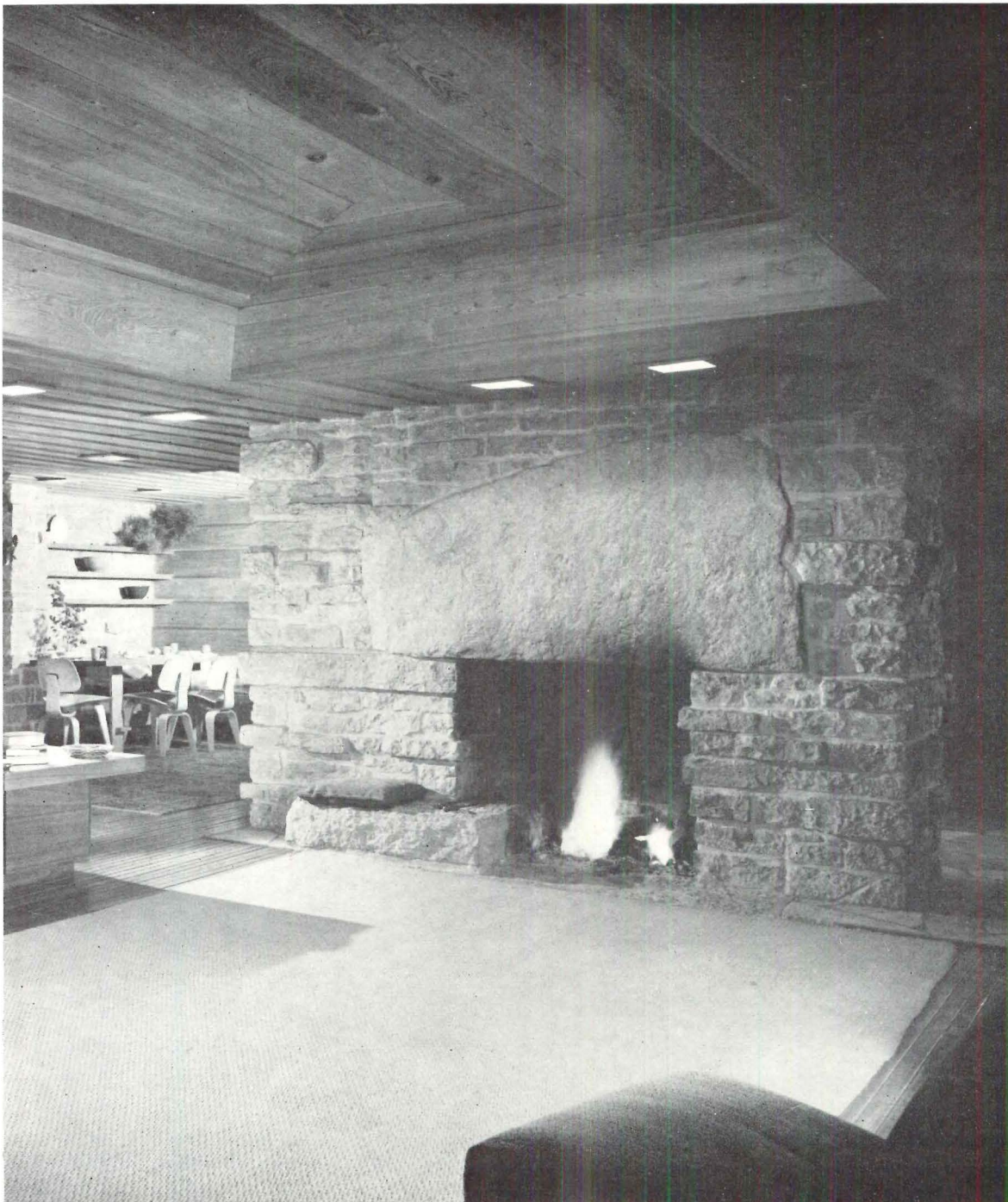

HOUSE FOR MR. AND MRS. SOL FRIEDMAN IN WESTCHESTER SUBURBS OF NEW YORK RAISES TWO BUILT-UP STONE CYLINDERS FROM A



TOY Hill is the dwelling of the Sol Friedmans and their little brood of Friedmans at Usonia Homes, Pleasantville, N. Y. The Friedmans wrote, "We want a happy house above all, Mr. Wright."

Friedman is a toy maker. Here is the toy-maker's "happy house" crowning its little toy hill. The little Friedmans all over the world would love this house.

It is unique in that it is the only house by myself yet built in the cooperative called Usonia Homes. There will probably never be another Friedman house nor any

closely resembling it. It is of the hill not on it and I believe the Friedmans are loving it more and more.

The house rises from a plan based upon two intersecting circles, one holding the main living area, the other on the first floor level holding the work center and guest room. On a second floor level come the bedrooms and a children's play area, opening into the two-story living room as a balcony section.

The building cylinders, laid up in native stone, are capped by hat-shaped roofs,

with turned-up brims (a reinforced concrete collar holding in place the rafters of the inner wooden cone) for a good look into the surrounding forest.

Above the long central living room glass strip the roof is carried on thin T-supports which do not interrupt the view (using the tilt of the building cylinder) and reflect the clouds and sky. Thin steel movable sash is used at the sides of the central casement windows emphasizing and strengthening the sweeping horizontal lines of the conical piles of the building.

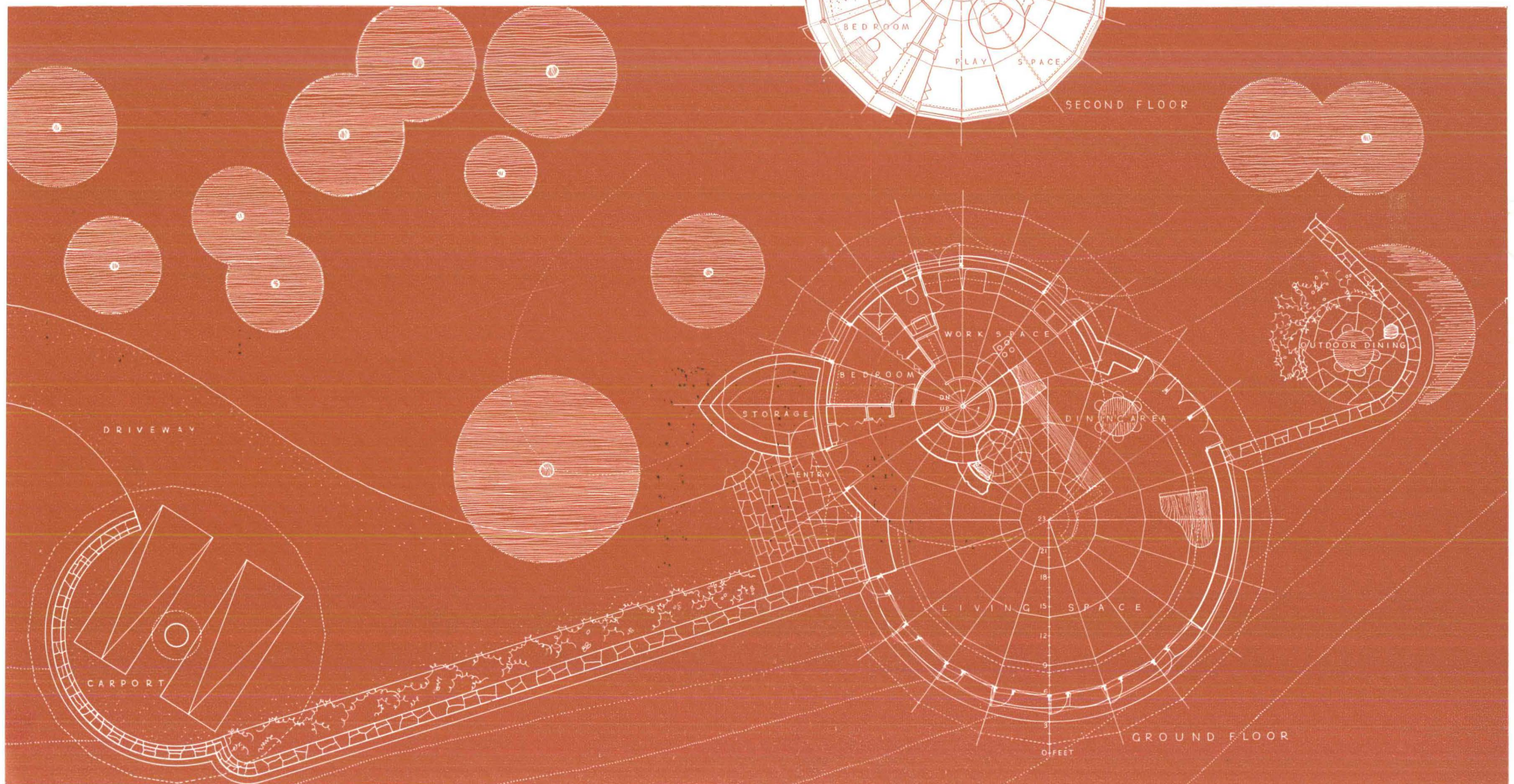



CAN YOU GIVE US SOME INSIGHT AS TO THE ORIGIN AND DEVELOPMENT OF YOUR OWN WAY OF WORK?

I can only tell you that lifelong endeavor of mine began as an early — probably the first — effort to demolish the box seen as Architecture. I began as a young architect-engineer. When I looked at the hideous efflorescent boxing in of humanity upon the Chicago prairies of the '90's, I soon realized that the corners of the box were not the economical or vital bearing points of structure. The main load of the usual building I saw was on the walls and so best supported at points some distance back from the corner. The spans were then reduced by cantileverage. So I took the corners out, put in glass instead: the corner window. I gave here a real blow to all boxing up or boxing in. With the bearing points thus drawn in and clearly established aside from the corners an-

other result was that box walls themselves became individual screens for interior space. Space could now be handled freely for either bringing in or shutting out the out-of-doors at will. This much was for the ground plan.

Later, say when the Johnson Administration Building evolved and coming from this earlier pursuit of the demolition of architecture as a box, I came upon the elimination of the horizontal corner, the corner between walls and ceiling. Before this all building was more or less the inexorable box in both plan and elevation. Architecture (until then) was finally closed off at the upper angle by the heavy artillery called a cornice. This time (the Johnson Administration Building), I took off the cornice at the ceiling, took out the wall beneath it and so in this sacrosanct

region I put in glass. Thus light was let into the interior space where light had never been seen before.

Making away with the box both in plan and elevation now became fundamental to my work. That opened the way for feeling the space within as the Reality of all true modern building, building not merely monumental. I have sought this liberation in some form or other in almost every building I have built. Here in this simple act may be found a "reason" — answering your question. These structures now bear the message of this liberation of space to space. It might be — must be — the basis for a new world concept, not only of Architecture but as a way of life which must eventually belong to a people loving freedom above license and practicing it in the name of Democracy.

PLAYROOM IN THIS CHILD-CENTERED HOUSE IS ON BALCONY EXTENDING INTO LIVING ROOM. DINING AREA OPENS TO GARDEN

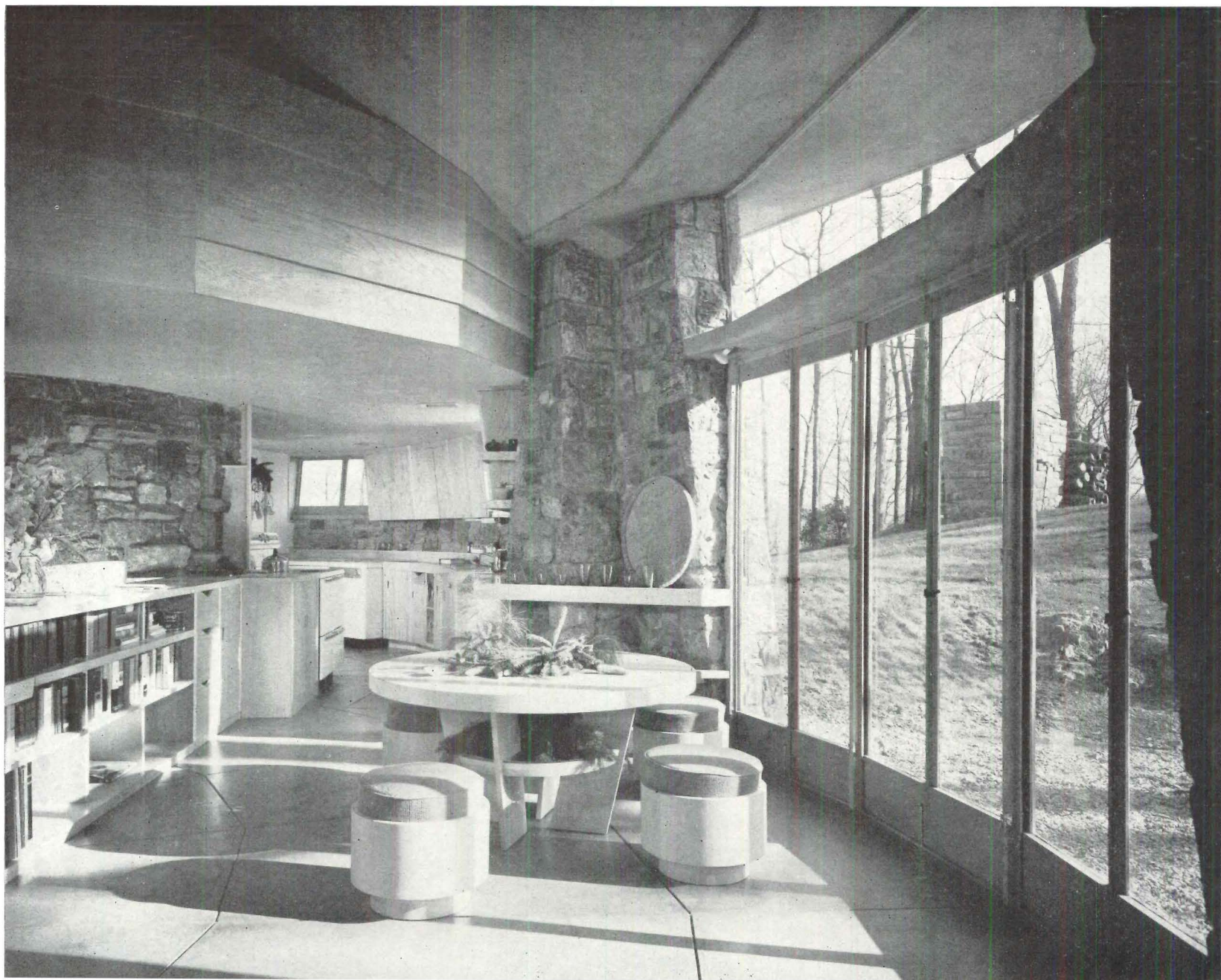



AND here again the buildings of Florida Southern College at Lakeland, this time closer to completion, although something like my own Taliesins, they will probably always be in a continuous state of growth. All construction is of steel-reinforced blocks and the entire scheme is Floridian, given this character by continuous esplanades which connect all the buildings.

Occasionally the esplanade becomes a building.

The administration building shown here with the chapel and library and seminars already completed was finished last year and work is now going ahead, under the courageous leadership of Dr. Ludd M. Spivey, upon the industrial arts building which is a further development of the

esplanade. When the Doctor flew to Taliesin with the commission for these college buildings he said he wanted me as much for my philosophy as for my architecture. I assured him they were inseparable.

Here at least is an education saga along the line of an indigenous American Architecture.

ALL PHOTOS © EZRA STOLLER, PICTOR

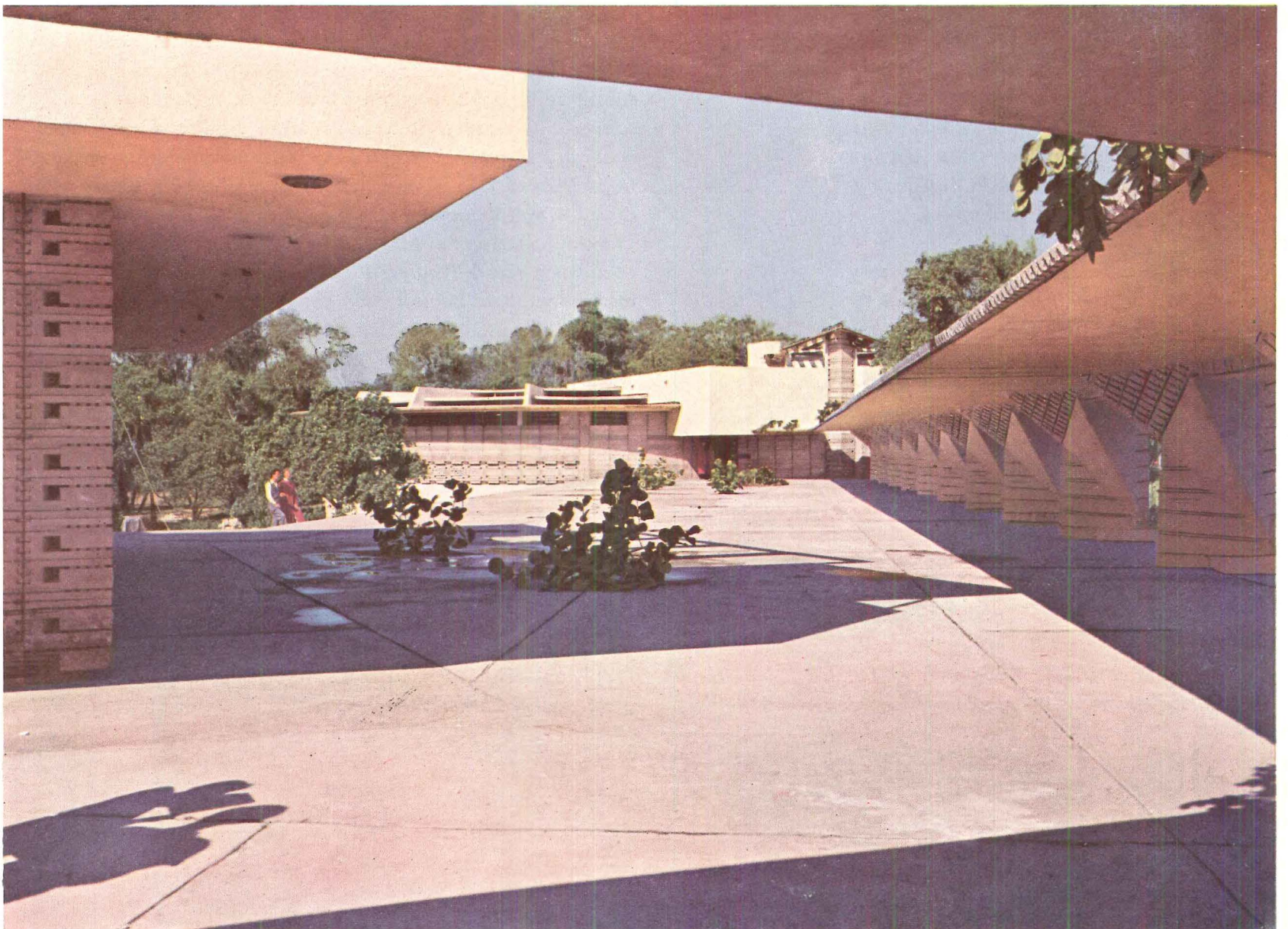



Note: Architecture, to us at Taliesin, is the great Mother Art. We feel and see Architecture not only as the basic structure of what we call our environment, now so uncultured, but also its integrity. Only our own creative ability can give us Beauty as native evidence of ourselves: a quality of peace. We mean this quality when we use the word repose.

In Oriental Art the great Buddha taught his prophets other words to use than "repose." Some of these are familiar in the drafting room at Taliesin. Some of them we do not yet understand. But the expression of this ancient cast-iron head of the Studio Buddha, changing with the sun, sometimes pervades our thought. Sometimes in his expression there seems evidence of the deep, beneficent inner quiet our Art so needs and that Taliesin covets. Complete repose (especially in action) is in man the quality of Being we see recorded in this benign countenance.

A DIALOGUE

Buddha: "Why, Son of the West, has your great nation never realized that Creative Art is implicit in faith in one's own Ideal. His Ideal is all any man will ever see of God! We Orientals believe FORCE in your nation is now becoming your substitute for Soul: substitute for the creative power of poetic science. That sense of force is false. Its vast mechanical apparatus is too busy among you raising a vast crop of weeds. Regardless of true flowers the policy of the West seems to drive this weed crop ahead to a dead end.

"Innate justice is lost to you. What you call 'technique' is a dead thing. Good 'technique' never precedes but must follow inspiration. You neglect any knowledge of your own true Nature. Because of this basic neglect you attempt to use the substitutes invented by your genius for machinery. This neglect — Son of the West — will make yours the shortest lived civilization among so many that have tried and are still trying to live as ancient Rome lived. Your civilization too will die as Rome died."

"Reverend Buddha, that prophecy does apply to our 'higher education' and the 'capitalist success-ideal' driving youth to gregarious life in our cities, and to war. To these comprehensive mistakes we owe the FEAR so imposed upon us by our 'politics'. Dishonest expediency there and where we must live is only natural to such 'success'. Nevertheless see in the little green valleys between the long ranges of wooded hills of our

country, love and reverence for Beauty. This humane growth you may find there where the hill-slopes are dotted with cattle or are alive with crops as little streams fed by flowing springs are running to the great rivers. Here and there, still native to their share of Earth you will find what, for lack of a special name of our own, we call America. Culture no longer lives in our cities. Cities now are only market places in which to sell fish. There are no fish in the streams."

• • • • •
Buddha: "If so, why do your people flock from your countryside to your big cities? Driven by some animal-instinct are they foregathering only to perish like flies crawling on a window pane? Your people will soon be victims of their own slaughter-machines. No. Son of the West . . . our ancient wisdom cannot respect such division of Will and Conscience in Man. We see in your ramping cities no vision. We see there only the trampling of self-seeking merciless herds. Your premiums are placed upon Mediocrity. The authority of the average is imposing and imposed upon until a fiction — 'the common man' — has become a national fetish. Does that not surely make of your pretended Democracy a failure? Seldom does authority among your millions know the difference between Freedom, a sacred inner thing, and the license that is only of animal-origin and dies like any animal."

• • • • •
"You speak Truth, great Buddha, for my people do yet realize

no other or better choice. From creatures-of-habit they came. How can you expect much more from them than the habitual raised to extremes by machinery? Artificially powered they now are by their own Machines and are becoming themselves more and more like machines.

"But in this little green valley, as in others elsewhere, a message is being prepared: a message you have helped make clear to us. We aim to reach our people with the living message we call Architecture. One day we may look back and see Truth we can touch and feel because we live in it. Our nation will some day realize the great source of true power is Spirit and find Truth coming to them from a source where they have looked for it least and last: the buildings they build to live in. You have the right to speak of Spirit as more Oriental than Western. But the Occident has known it too. Some day East and West as one will waken to the honest practice of what we call a natural or organic Architecture. Today — on Earth everywhere youth is waking and working, loving this old, yet new, integrity."

Buddha: "Then you may not die as all civilizations preceding yours have died! Sharing our ancient Wisdom, you may live . . . not forever, no Forever, too, is finite. We will know eternal Life together. This meeting of East and West in thought will become a mighty feeling only when this vicarious Force you call the Machine becomes, instead of your master, your expedient servant. Then only will you know Freedom."

FRANK LLOYD WRIGHT
TALIESIN DECEMBER 15th, 1950

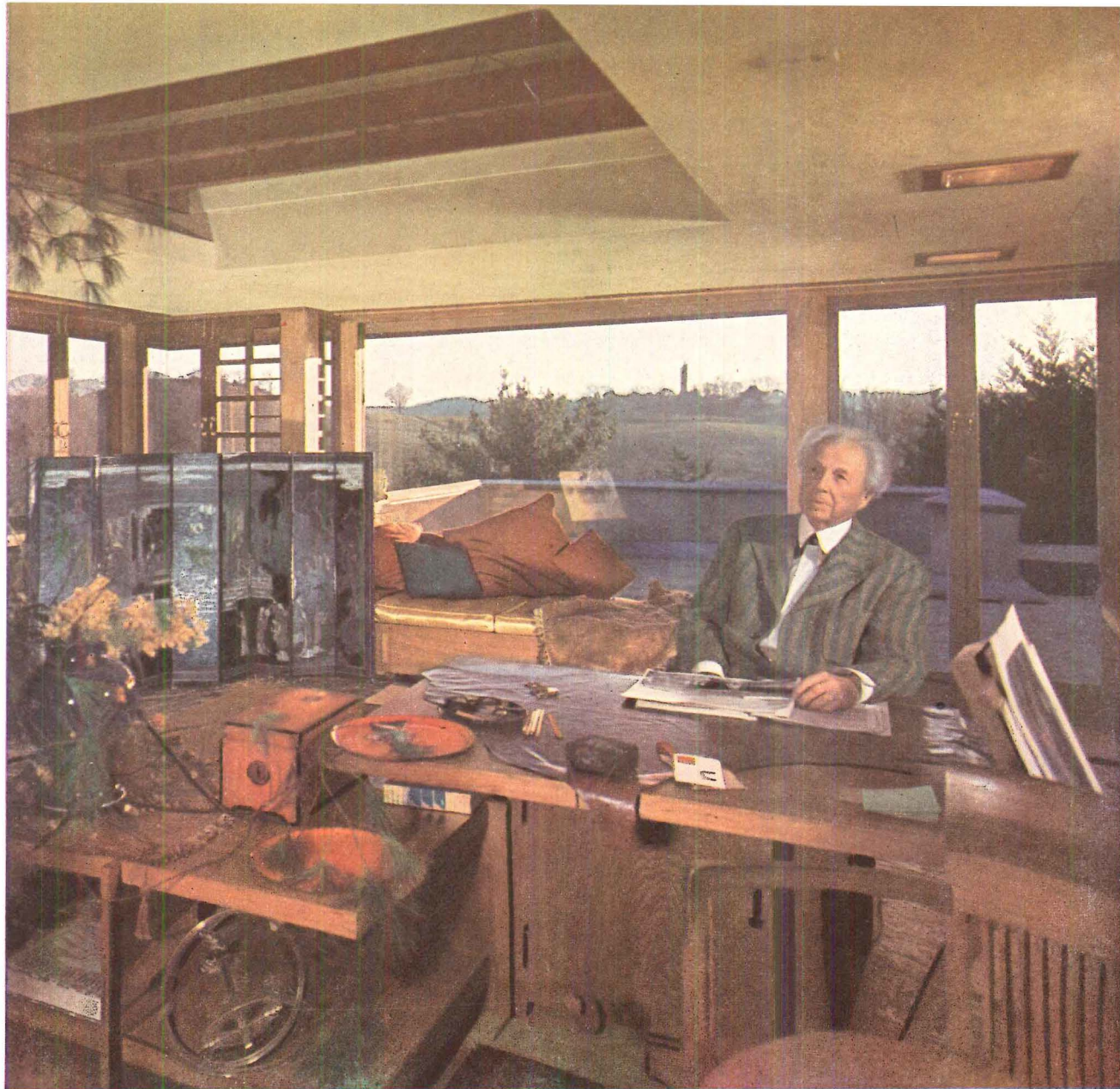

FRANK LLOYD WRIGHT, 81, is now in the 56th year of an architectural practice which has changed the shape of building throughout the western world. One of the many remarkable facts about this remarkable man is amply documented on the preceding pages. This is that after more than a half-century of work there has been no diminution in his overflowing creative energies, his unshatterable vitality.

This enormous vitality—perhaps more than anything else the essential element of genius—has in his case an enormous range. It extends from an ability to sit quietly and continuously at a drafting board until some great plan like the Pittsburgh Point Development grows into complete life under his hands—to an ability to take a lively interest in just how the lamb is to be roasted for dinner. Those who have seen FLLW at work at one of the two Taliesins are likely to come away with some sharp impressions. One is that no concern is ever too small (the details of our own publishing project, for example) to merit his full and precise attention. On the other hand, no design problem is ever so big or so challenging as to break the even rhythm of the way this man works. To see Wright at work at his drafting board, under the “abstract forest” of the great oak trusses that span the Taliesin drafting room, is to understand what he means when he speaks, as he does elsewhere in these pages, of that “complete repose known only in action.”

Ezra Stoller’s photograph here gives something of the unity between this great architect’s life and his work. It shows Wright in his studio-bedroom at Taliesin (a Welsh word meaning Shining Brow), a room looking out over the gentle Wisconsin hills where his Welsh grandfather so long ago taught him to “add tired to tired and work again.” The wooden windmill, “Romeo & Juliet,” which confounded the neighbors some 40 years ago, shows in the background. This beautiful room, where Wright works surrounded by the serene art of the East he loves, was not there six months ago. Like the oaks and pines around it, Taliesin itself is continually pushing out new growth; the young apprentices who compose the Taliesin Fellowship are forever building. Into this room, in a minute, will come dark-eyed Olgivanna, the wife whose serene grace guards the pattern of Wright’s day, with a reminder that it is time to stop for a walk before lunch.

TRANSLATIONS

(Pagina 75) L'Elio-laboratorio per la Johnson Wax Company, Racine, Wisconsin con piani a sbalzo dal corpo centrale in cemento armato contenente tutti i servizi e gli impianti del laboratorio. (Pagina 77) La costruzione della torre è simile a quella dell'edificio dell'Amministrazione del 1936: cemento armato, pareti in mattoni rivestiti da tubi di vetro. (Pagina 78) La centralizzazione degli impianti e l'incanalatura degli ascensori raddoppiano l'area netta di lavoro. Le tubolature orizzontali di vetro ammettono luce diffusa su tutta l'area. (Pagina 81) Piani a pianta quadrata si alternano a piani circolari intermedi. La torre poggia su una fondazione in cemento armato di mt. 17.

(Pagina 82) La casa per Mr. e Mrs. Lowell Walter presso Quasqueton, Iowa apre l'area principale del soggiorno ed il giardino coperto alla vista di ambedue i lati del fiume in curva. Il padiglione delle imbarcazioni alla punta del promontorio. Mattoni rossi selezionati, interno in noce. (Pagina 84) Tetto in lastre di cemento rivolte su supporti metallici. Vista dell'ingresso con l'area della servitù e l'autorimessa a destra.

(Pagina 86) L'abitazione di Benjamin Adelman nel Milwaukee dimostra un geniale adattamento di blocchi standard di cemento. La casa lineare è coperta da tetto asimmetrico con lucernari lungo il colmo. (Pagina 88) Vista del pranzo dall'area principale del soggiorno attraverso le vetrate della galleria. Il centro di lavoro dietro il camino. Sfinestrate al lato di ingresso dell'abitazione danno luce al lungo corridoio che porta alle camere da letto. Il ritmo delle intelaiature interrompe la

profondità del vestibolo.

(Pagina 90) La House II di Herbert Jacobs nelle campagne presso Madison, Wisconsin. Emiciclo solare piazzato contro il vento. Il giardino sottostante affaccia a Sud. Il terreno di scavo è stato usato per la protezione della scarpata intorno il lato nord del cerchio di pietra. (Pagina 93) Le camere da letto aprono sul mezzanino. La vista notturna dal giardino presenta la suddivisione delle attività nel lungo ambiente.

(Pagina 94) L'abitazione di John Pew in Madison, Wis. dimostra come Wright possa liberarsi dallo "iscitolamento" pur nei limiti di una piccola casa. Lo spazio corre ininterrotto al di sotto della casa sostenuta da una colonna di pietra ad un estremo della collina. (Pagina 97) Costruita in tavolati di cipresso sovrapposti e pietra locale all'interno ed all'esterno, la casa gode di ampi terrazzi ad ambedue i piani largamente aperti alla vista del lago. (Pagina 98) L'abitazione per Mr. e Mrs. Sol Friedman in Westchester nei sobborghi di New York, è composta di due cilindri di pietra che si elevano dalla piccola collina. Un muro di pietra connette i due cilindri intersecanti della casa al tetto in cemento dell'autorimessa a sinistra. (Pagina 101) In questa casa, il cui nucleo centrale è dedicato al bambino, la camera da gioco è sistemata sulla balconata che si estende nel soggiorno alto due piani. L'area del pranzo apre sul giardino.

(Pagina 103) Florida Southern College. La torre della cappella introduce completa luce diurna nell'interno. (Pagina 104) Vista della biblioteca circolare dalla spianata.

(Seite 75) Sonnenlicht-Laboratorium für Johnson Wax Co., Racine, Wisconsin. Stockwerke auskragend von einem Eisenbeton-Kern, der alle Rohrleitungen und Frischluft Kanäle des Laboratoriums enthält. (Seite 77) Turmkonstruktion ist ähnlich wie die des angrenzenden Administrationsgebäudes aus dem Jahre 1936: Eisenbeton, Backstein-verkleidung und Glasröhren für Tagesbeleuchtung. (Seite 78) Zentralisierung der Rohrleitungen und des Fahrstuhlschachtes bedeutet Verdopplung der nutzbaren Arbeitsfläche. Fenster aus horizontalen Glasröhren lassen überall gestreutes Licht ein. (Seite 81) Rechteckige Stockwerke wechseln sich mit runden Zwischengeschossen ab. Der Turm ruht auf einem 17-Meter Eisenbeton-Fundament.

(Seite 82) Haus für Herrn und Frau Lowell Walter in der Nähe von Quasqueton, Iowa, öffnet Hauptwohnraum oder Gartenzimmer weit zur Aussicht auf beide Seiten des Flusses. Boothaus auf der Landzunge. Ausgewählter roter Backstein, Innenausführung in Nussbaumholz. (Seite 84) Abgerundetes Eisenbetondach auf Stahlstützen. Ansicht der Eingangsseite zeigt Dienerschaftswohnung, Kraftwagenunterstand zur Rechten.

(Seite 86) Benjamin Adelman Haus in Milwaukee zeigt, was geschickte Behandlung von Zementhohlsteinen erreichen kann. Das langgestreckte Haus ist überdacht mit einem unsymmetrischen Giebeldach, mit Oberlichtern an verschiedenen Stellen längs des Firstes. (Seite 88) Durchblick vom Hauptwohnraum durch glasumschlossene, zum Esszimmer führende Gallerie. Küche hinter dem Kamin. Schlitzförmige Fenster an der Eingangsfront beleuchten langen Korridor zu den Schlafzimmern. Rythmus der Holzkonstruktion unterbricht die tunnelartige Halle.

(Seite 90) Herbert Jacobs Haus II in der Nähe von Madison, Wisconsin. Windgeschützter, der Sonne zugekehrter Halbkreis. Vertiefter Garten gegen Süden gerichtet. Erdaushub liefert Aufschüttmaterial für Schutzwall um Nordseite des steinernen Halbkreises. (Seite 93) Schlafzimmer sind auf dem Halbgewölb angeordnet. Ansicht, gegen Abend, vom Garten auf das Haus zeigt die vielfältige Benützbarkeit des langen Raumes.

(Seite 94) John Pew Haus in Madison, Wisconsin, zeigt wie Wright auch innerhalb der Grenzen eines verhältnismässig kleinen Hauses Freiheit von der Schachtelform erreichen kann. Das Land streckt sich ununterbrochen unter dem Hause entlang; an einem Ende des hügeligen Terrains ruht das Haus auf einer Steinsäule. (Seite 97) Das Haus, sowohl aussen als innen aus waagerechten Zypressenbrettern und Stein, hat in beiden Stockwerken breite Terrassen weit offen zur Aussicht auf den See.

(Seite 98) Haus für Herrn und Frau Sol Friedman in Westchester bei New York. Zwei Steinzyylinder auf einem kleinen Hügel. Eine Steinmauer verbindet die zwei einander überschneidende Zylinder des Hauses mit dem Wagenunterstand zur Linken der von einem aufwärts gewandten Betondach geschützt wird. (Seite 101) Das Spielzimmer in diesem besonders auf Kinder abgestimmten Haus befindet sich auf einem Balkon, der in den zweigeschossigen Wohnraum hineinragt. Der Essplatz öffnet sich gegen den Garten.

(Seite 103) Florida Southern College. Das Tageslicht fällt in den Innenraum durch die Mitte des Turmes. (Seite 104) Ansicht der kreisförmigen Bibliothek von den Pergolen aus.

Laboratoire-Solaire pour la Johnson Wax Co. de Racine, Wisconsin, avec planchers à porte-à-faux reposant sur un пиллер в виде бетона, опирающийся на центр, всевозможные трубы и каналы, необходимые для функционирования лаборатории.

Page 77 — La construction de la tour est la même que celle du Bâtiment Administratif terminé en 1936; c'est à dire: structure en béton armé et murs en brique recouverts avec tubes de verre.

Page 78 — Conduits de conditionnement et groupes d'ascenseurs centralisés doublent, pour ainsi dire, l'espace destiné au travail. Les tubes de verre horizontaux diffusent la lumière d'une façon uniforme, à tous les coins de l'espace disponible.

Page 81 — Les plans carrés des étages principaux alternent avec les plans circulaires des étages intermédiaires (Mezzanines). La tour repose sur une fondation carrée en béton armé de seize mètres de côté.

Page 82 — Maison de Mr. et Mme. Lowell Walter près de Quasqueton, Iowa. Le "living space" ou chambre-jardin s'ouvre hardiment à la vue des deux rives de la courbe du fleuve; avec la remise-à-bâteaux située à la pointe du promontoire. Brique rouge de choix, Intérieurs en noyé poli.

Page 84 — Toit en dalle renversée de béton reposant sur des supports en acier. La vue de l'entrée montre le quartier des servants; le garage-en-plein-air (Carport) est à la droite.

Page 86 — La maison appartenant à Mr. Benjamin Adelman à Milwaukee est un bel exemple des résultats qui peuvent être obtenus par un usage adroit des blocs de béton ordinaires. La maison, de développement essentiellement rectiligne, est couverte avec un toit asymétrique à plans inclinés avec admission de lumière naturelle aux points appropriés du faite.

Page 88 — Vue de la pièce principale et de la galerie à pans de verre qui mène à la salle-à-manger. Centre de travail, derrière la cheminée. La bande de fenêtres étroites à ruban, située du côté de l'entrée, illumine le long corridor des chambres-à-coucher. Le rythme des membres verticaux de la structure détruit l'effet de tunnel qui

serait autrement créé par la perspective du corridor.

Page 90 — Maison de Campagne appartenant à Mr. Herbert Jacobs II près de Madison, Wisconsin. Plan semi-circulaire permettant pleine utilisation de la lumière solaire et fournissant en même temps une protection efficace contre le vent dominant. Le jardin, à un niveau inférieur, est orienté au sud. Le produit des excavations nécessitées par ce jardin est utilisé pour former un talus protectif autour de l'hémicycle en pierre.

Page 93 — Les chambres-à-coucher donnent sur le mezzanine. Vue, regardant du côté du jardin vers la maison, montre clairement la diversité d'utilisation de l'espace en longueur de la pièce principale.

Page 94 — Maison appartenant à Mr. John Pew à Madison, Wisconsin, montre comment Wright est capable de se libérer avec aisance des restrictions imposées par la simple géométrie d'une maison relativement modeste. L'espace se déploie sans interruption au dessous, avec la maison supportée par une colonne en pierre à une des extrémités du terrain ondulant.

Page 97 — Construite en maçonnerie de pierre locale et en bois de cyprès à l'intérieur aussi bien qu'à l'extérieur, cette maison est flanquée de larges terrasses donnant franchement sur le lac à tous les deux étages.

Page 98 — Maison de Mr. et Mme. Sol Friedman à Westchester, un faubourg de New York, est constituée par deux volumes cylindriques en pierre, bâtis sur une colline miniature. Le mur de pierre unit les deux volumes cylindriques secants de la maison au toit recourbé en béton couvrant le garage-en-plein-air que l'on aperçoit à la gauche.

Page 101 — Dans cette maison, dont le plan est conçu avec l'idée de satisfaire les besoins de l'enfant avant tout, la chambre-de-jeux donne directement sur le balcon qui se termine sous la forme d'une "living room" à deux étages. L'espace-à-manger donne sur le jardin.

Page 103 — College Florida Southern. Le clocher de la Chapelle assure l'éclairage naturel uniforme de l'intérieur. Bibliothèque vue de l'esplanade.

(Стр. 75) Омываемая солнцем лаборатория для фирмы Джонсон и Ко в г. Расин, (Висконсин). Этажи консольной конструкции вокруг центральной основы, внутри которой скрыты все коммуникационные устройства и трубы обслуживания. (Стр. 77) Материал постройки башни тот же, что и в здании Правления (1936 г.), т. е., железобетон с легким заполнением, наружные стены из стеклянных трубок. (Стр. 78) Благодаря централизации всех каналов и шахт, выигрывается рабочее пространство почти в два раза. Применением прокладок между стеклянными трубками наружного заполнения достигается равномерное, рассеянное освещение. (Стр. 81) Квадратные этажи чередуются с круглыми галереями. Башня покоится на фундаменте, заглубленном на 17 метров.

(Стр. 82) Особняк семьи Ловела Волтера вблизи Коскетона (Айова). Из основного внутреннего пространства, запроектированного как зимний сад, открывается вид на обе стороны речной излучины, внутри которой расположено строение. На острове мыса находится ангар для лодок. Внутренняя отделка — красный кирпич и ореховое дерево. (Стр. 84) Закругленная кровля из бетонных пластин на стальных стропилах. Со стороны подъезда видны помещения обслуживающего персонала и навес для автомобиля.

(Стр. 86) Дом Беннамина Адельмана в Милwaukee может служить примером мастерского использования стандартных бетонных блоков. Здание вытянутой в плане формы с высокой ассиметричной кровлей, параллельно коньку которой расположены витражи верхнего света.

(88 стр.) Вид из большой гостиной сквозь остекленную галерею, ведущую в столовую. За стеной с каминным сосредоточены хозяйственные комнаты. Узкие окна переднего фасада освещают корридор,

ведущий в спальню. Ритм рам сглаживает монотонность корридора.

(стр. 90) Второй жилой дом Герберта Якобса в сельской местности близ Мадисона (Висконсин). Обращенный к солнцу полукруг является защитой от ветров. Сад расположен в обращенной на юг выемке, грунт из которой использован для образования защитной насыпи северной стороны. (стр. 93) — Спальни отнесены в мезонин. При вечернем освещении из сада видно все многообразие использования этого длинного помещения.

(стр. 94) На примере свободного решения этого небольшого особняка, принадлежащего Джону Пью в Мадисоне (Висконсин) Райт показывает возможность преодоления обычных коробочных форм.

Пространство свободно растекается внизу, а само здание приподнято на каменной опоре с одной из сторон небольшой возвышенности.

(стр. 97) Сооруженный из кипарисового дерева (внутренняя и наружная обшивка в нахлестку), а также из местного камня, дом имеет в обоих этажах широкие террасы, выходящие на озеро.

(стр. 98) Дом семьи Соломона Фридмана в Вестчестерских окрестностях Нью-Йорка представляет собою два каменных цилиндра, возведенных на искусственном холмике. Слева каменная стена объединяет эти пересекающиеся цилиндры с изогнутой бетонной кровлей навеса для автомобилей.

(стр. 101) Комната для игр в доме для семьи, где дети занимают основное место, представляет собой антресоли, выходящую в двухэтажную гостиную. Столовая выходит в сад.

(стр. 103) Южно-Флоридский колледж. Башни часовни, где предусмотрено полное дневное освещение внутреннего пространства.

(стр. 104) Вид из променада на круглую библиотеку.

Architect and Builder (cont'd)

1950 was not alone a year of amazing home-building volume. It is still more memorable as a critical year of decision for the home builders—a critical year when, thanks to wise leadership, the right decision was made and translated quickly into action.

For 1950 was the year when the volume builders, having solved most of the problems of low cost quantity construction that lie within their power to solve (the rest must await general adoption of modular coordination and the dynamiting of various inefficiencies now profitably entrenched in local codes, FHA requirements, and union rules), lifted up their eyes to face a perhaps still greater problem they had too long avoided—the *problem of making the design and livability of their homes as good as their production and economy.*

This, of course, was impossible without first setting up partnership with the architects. Twelve months ago such a working partnership seemed many years away. Today it lies within the easy reach of any builder—or architect—smart enough to help himself. And that almost unbelievable advance, we believe, is the great building milestone of 1950.

There are still some who misunderstand the year's progress and regret the October decision of the AIA-NAHB committee against working out a cut and dried national formula for just how the architect must be paid for doing what. But such a formula was as impossible as it was unnecessary, and the whole unsolvable problem simply disappeared as soon as the committee recognized that no ethical question was involved to require a ruling.

Specifically, the architects first agreed that their services to volume builders should be compensated as product design rather than by a conventional architect's fee. Then both parties agreed that a national standard of product design compensation should not be set up. The positive effect of this negative decision is to set the architects and builders of every community free to work out their own arrangements for mutually profitable teamwork.

The problem now is to make more builders realize how much the architect can add to the livability and sales appeal of their homes, so a good fee for a good architect should add to their own profits instead of coming out of them. Builders should be not only willing but eager to make it well worthwhile for the smartest architects to devote their talents to housing developments. They should realize it could be to their own advantage to raise the royalty on every added house to around \$100.

A second pressing problem is to make more top-flight architects realize what a tremendous, profitable and socially significant market is suddenly being opened to them—sometimes a million houses a year, on which their product design fees might run over \$100,000,000.

The architect and builder committees are now focusing their efforts close to these two problems, figuring out ways in which the architects can serve the builders better and thus earn more substantial compensation.

* * *

Meanwhile, there is almost sensational news of the progress already made towards these final objectives. This news is the tremendous success of the small house design competition sponsored by the National Association of Home Builders and this magazine.

The very fact that any sort of architectural competition should be planned by the Home Builders (so long indifferent to architecture) was news and a major sign of the times. The fact that the Home Builders are making this the biggest architectural competition ever held is doubly significant.

The response of the architectural profession is equally exciting. More than 11,000 applications for entry blanks poured in. Some 3,000 finished plans were submitted, many of them from top-flight architectural offices and of very high quality. Never before has any architectural competition aroused anything like such interest.

What better evidence could we seek that architects and builders alike are moving eagerly towards a partnership that will be richly profitable to both and still more profitable to every home buyer?

WANTED: SUBSTITUTES THE BUILDER CAN USE

when critical supplies
are diverted for war production

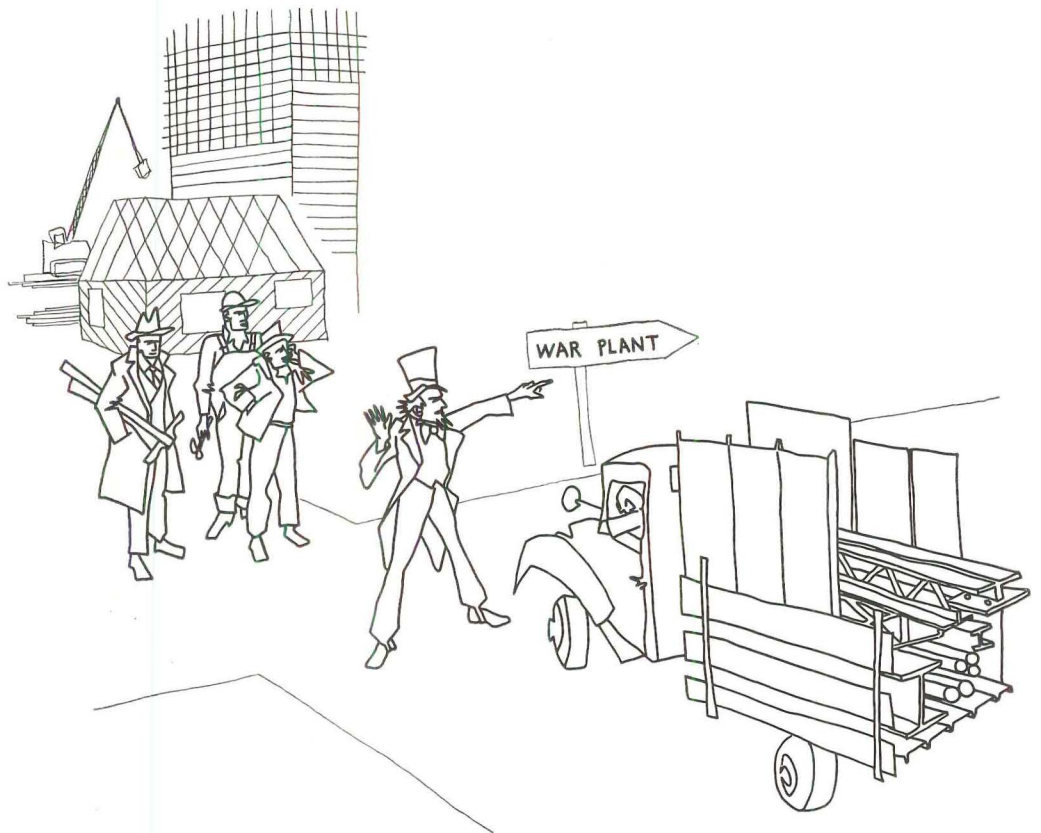

As the new year began, Joe McLannon, owner of the McLannon Construction Co. and a typical builder, realized that to stay in business through 1951 he would have to fight for materials as he had never done before.

The government could well say it hoped 850,000 housing units would be built in 1951. But he knew thousands of builders would be competing mightily aggressively with him for materials for their share of the business.

Joe had proved before that he was a versatile, resourceful builder. He had done defense houses in the last war and knew what a headache it was to get material even with priorities. His war experience came in handy because nearly every day since 1945 he had scrambled and connived for almost everything he had put into his houses. But as he read the papers and talked with suppliers it was as clear as a 3 in. knot in a pine board that this year he would have to connive and scramble as never before in peacetime.

So Joe did what most other builders were doing: on the assumption that Washington would let him build houses for perhaps a year if he could get along with a minimum of critical materials, he tried to anticipate what shortages might develop.

This was a spot where he needed all the help of his architect, so with him and his key men around him, they went down the list of critical items. Where could they substitute things they could get for critical items?

"This way of cutting out metals, cement and other things doesn't make sense to me" said Joe's foreman. "Here the people need houses and the government wants us to build them. But suppose we got bombed and they asked us to build houses—you know, emergency stuff but still good construction. Any builder knows he could save all kinds of metal in his plumbing system, a lot of cement and other stuff if two things were different."

"Meaning what?" said Joe.

"Meaning if local building codes were changed and if the building trades unions weren't so hidebound . . ."

"Listen to the dreamer" sneered the engineer.

"If you really want to dream" said Joe, "dream that FHA and the rest of 'em in Washington want to save materials. We could do a lot of simplifying in our houses if the government got serious about it. But let's stop butting our heads against that wall. Now how can we cut out some metal?"

Framing and structural members

On one group of houses they had used prefabricated steel trusses and it was simple to use wood instead. On occasions they used steel or iron posts in the basement and these could be replaced with wood or masonry piers. On custom-order houses they used steel I-beams over long stretches of windows for which wood beams could be used as substitutes. There was a variety of nonmetallic alternatives for metal insulation. In their slab-on-ground houses they used steel reinforcing wire that could be eliminated if they thickened the slab.

Windows and hardware

Wood windows were an easy replacement for aluminum and steel, including the basement. In using double-hung wood windows they guessed they might eventually run into shortages of metal for counter balancing them and that they would have to find substitutes. Window hardware might eventually be a problem and when that day came they could consider using horizontal sliding windows that required almost no hardware.

They knew of no substitutes for metal in door locks, but knew that glass, wood or plastic knobs would be satisfactory. For hardware in their overhead garage doors they were aware of no substitutes except going to the old type hinged doors. On interior doors they could omit locks. In some instances they could use sliding doors that did not require metal tracks.

Hardware for fireplaces could be eliminated with some study. The flues could be redesigned to omit the damper if metal became short enough. The clean-out door in the basement could be replaced with a temporary brick plug that could eventually be modified to permit a door to be installed.

Heating system

McLannon and his staff made a rough estimate of the amount of metal in one of their typical small houses and concluded they were using about 2,700 lbs. of steel and about 210 lbs. of copper. A good share of this was in their heating system, and they knew they would have to make savings here.

"When we use the last of our copper tubing," Joe told his people, "we'll go to steel or iron pipe for radiant heating. When that becomes too short, we'll switch from radiant warm water in the slab to warm air through clay or concrete ducts."

What the builder can learn from the manufacturer about the supply of materials

At the end of the year few manufacturers were able to predict accurately how much of their output in 1951 might be available for nongovernment building. Until the government announced a decision on priorities and end-uses of materials, producers could only guess what might happen. Following are their best estimates:

Copper: "Copper is very short," said a copper and brass firm spokesman. "Some orders are not filled for six months and it looks to us like copper will soon be cut out altogether for houses. The National Production Authority order banning end use of copper in 300 products on March 1 will stop manufacture of copper hardware, sash, screens, gutters and dozens of other products. Copper products are first on the list for which builders must find substitutes."

Aluminum: there will be some aluminum for building materials until airplane production gets going. Some aluminum window firms hope they can fill their contracts up to June 1 but other producers believe that a stop-order is now being written to end production on April 1. Aluminum screen fabricators are pessimistic over their chances for remaining in business. Other aluminum products are certain to be drastically curtailed except for high priority buildings.

Steel: Steel production is at an all-time high but demand is so great there are serious shortages. Some relief may come if automobile production is cut. Builders now wait several months for steel and it is sure to be very tight in 1951.

Other metals: iron, tin, lead, zinc, chromium plated articles and most of the light alloys like magnesium are already tight and almost sure to become tighter.

Lumber: if lumber production stays at its 1950 level and if one-third fewer houses are built it would appear that there would be no shortages in 1951. If the government builds great new projects there may be shortages in some areas.

Plywood: the Douglas Fir Plywood Assn. reports there is plenty of plywood. Production in 1950 was 20 per cent higher than in 1949. Half goes to industrial uses, one-quarter to new housing, one-quarter to other construction.

Brick and tile: there is no shortage of brick and none is expected. There may be temporary shortages in some colors such as buff and gray in some areas. In the tile field only glazed tiles have been short and some firms have delays of five months in filling such orders. There is plenty of clay for brick and tile; the only problem may be manpower and fuel.

Cement: the supply was tight last year because everyone wanted it between May 1 and Nov. 1. There was a shipping problem rather than a production problem. Producers anticipate demands this year will be slightly less than last and that they can fill orders. Government orders for defense projects however might upset the present balance.

Plastics: there is no great untapped source of plastics for building products. Nearly all plastics for building use are already critical because of new demands from other industries. Great amounts of plastics will be used in military production when it gets rolling. Plastics could provide building substitutes but the industry predicts no new products that are not on the market now will be made.

Asbestos: the supply depends on the attitude of the French-Canadian miners who actually control the amount of asbestos produced. If they approve of the U.S. war effort there will be no asbestos shortage. The immediate outlook for asbestos products is that the supply will continue to be about what it was last year.

Rubber products: the supply of raw rubber is likely to become more critical and the price trend is upward. However a number of so-called rubber products such as radiant panels, rubber and plastic waterproofing materials and rubber for wire insulation actually use more synthetics than rubber. Manufacturers of such products are not alarmed over shortages in the near future.

The little things: "What will make life miserable for us," said an operative builder "will probably not be shortages in the big things. We'll know about them before we start building. What will drive us crazy will be the little things: hardware and nails and the little odd items which hold you up. You can't anticipate that kind of trouble and it's the worst of all."

We won't talk about that until we come to it, but we can make it work." They had heard of at least one form of plastic pipe that would take warm water and that could be used for radiant heating. But the manufacturer didn't recommend it for that purpose. If a valve stuck and water became too hot the pipe would deteriorate.

There are already more than 500 houses in the country that are using warm air heating through the slab. (See BUILDING, Aug. '50 for one system.) Usually metal ducts carry the heat to floor or sidewall registers, but clay tile, asbestos cement board, or prefabricated asbestos ducts could be used. Experiments have shown that ducts can be formed in the cement slab without a lining of any kind. Concrete is poured around a cylindrical form that is removed when the slab is hard.

Some builders they knew were considering using the crawl space under basementless houses as a warm air plenum. A ductless, warm-air furnace could blow air into the plenum from which it would flow up to the rooms through floor registers.

When sheet metal ducts become scarce for standard, warm-

air heating systems, asbestos cement ducts, either rectangular or round, can serve instead.

In fact they can be used in large air conditioning systems. More than 20 miles of asbestos ducts were used by engineer Charles S. Leopold in the Pentagon Building and they have given excellent service. Cost is about the same as metal ducts that are insulated. Maximum size is 23½ x 23½ in. and this is a limiting factor, although two ducts can be put side by side.

Manufacturers of ductless furnaces might ask: why bother with ducts at all? And for larger houses where one such furnace isn't enough, put in two, they say, and let the house buyer get zonal control with heat when and where he needs it.

Then there are the various forms of electric heat which manufacturers claim Washington is in sympathy with because so little metal is used. There are no furnaces, boilers, ducts, water pipes, radiators or grilles. True, some copper wire is necessary and in one case some aluminum backing, but the amount of metal is less than 1 per cent of that required in a standard heating system.

(Continued on page 148)

TWELVE ARCHITECT SUGGESTIONS FOR THE MERCHANT BUILDER

1. **The glass gable end**
2. **Holes in the ceiling**
3. **The mirror trick**
4. **Interior bathroom**
5. **The vanishing dining room**
6. **The eating bar**
7. **Open kitchens**
8. **Folding kitchens**
9. **Outdoor rooms**
10. **Reflecting pools**
11. **Chimneyless fireplaces**
12. **Raised fireplaces**

In their designs for custom-built houses, architects have for years been working out and testing new ideas which, a few years later, have been picked up and put into general use in hundreds of thousands of development houses. Among the ideas the architects started and the builders now have brought into general use are the window wall, the open plan, the strip window for bedrooms, the storage wall, the wide overhang and the roof ceiling.

On the next 15 pages is a roundup of 12 other architect ideas which can easily be applied to builder houses. The editors are confident that the ideas presented here—as well as the many ideas contained in the houses published in *BUILDING* each month—can be adapted to the mass-volume house. Such adaptation will be most successful where architect and builder collaborate in the design from scratch, working as a team, each profiting from the other's special knowledge and each convinced that, together, they can enormously improve our design for living.

Wide roof overhang, standard builder practice now, saves the cost of gutters and downspouts. Architect: Paul Beidler.

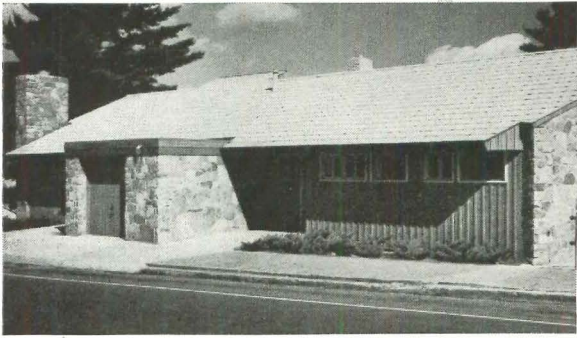

High strip windows, provide more wall space for better furniture placement in small bedrooms. Architect: J. L. Sert.

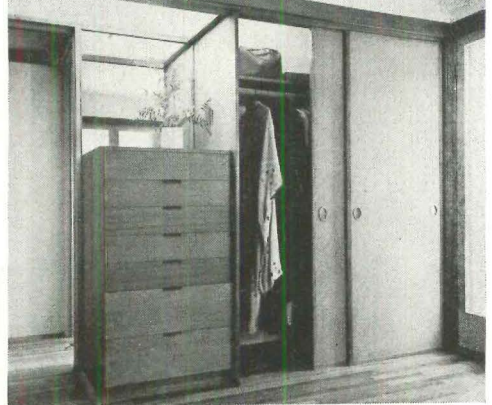

Built-in furniture and storage walls, pioneered by architects, have become prime merchandising features in subdivision houses. Designer: Harwell H. Harris.



Builder's house, above, was built by Levitt & Sons of Long Island. Its design incorporates a number of ideas demonstrated earlier in architect-designed, contract-built houses. They have made it a top merchandising attraction in the \$20,000 bracket.

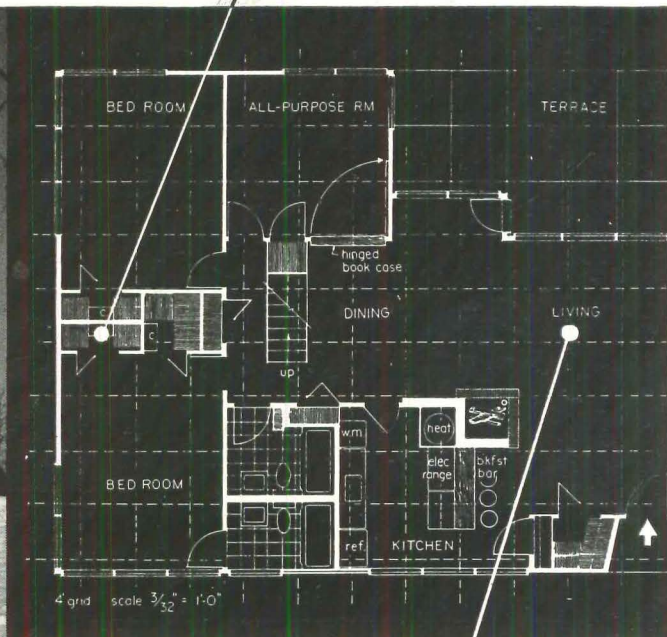

Open planning (below) is the architect's prime weapon in achieving a sense of interior spaciousness. Builders have begun to learn of its value for their houses. Architect: Marcel Breuer.



Glass walls—the hallmark of contemporary design for most people—have begun to make their appearance in builder's houses. Architect: Lawrence Perkins.

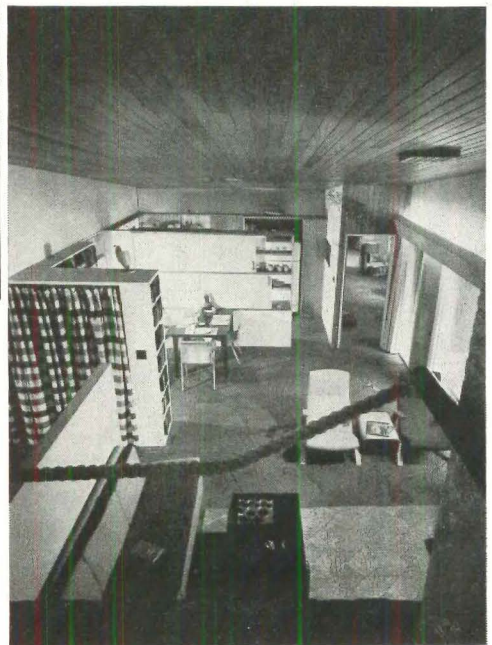



Remodeled Westchester farmhouse has glass gable ends by architect Henry Hebbeln, designed to light and ventilate 1½-story living room and attic bedroom (above).

1. Glass gable end

Builder's problem: to find a cheaper way to provide more light and air for an attic room.

Architect's suggestion: Why not frame the gable end in so much glass that there will be no need for dormers, which are expensive and inefficient for both lighting and airing, and sure to cause leaks. Constructionwise, the glass gable ends need be little more than double-glazing between load-bearing mullions, with enough panes hinged to provide good ventilation. Even for custom-built houses, this structurally simple idea still needs further working out.

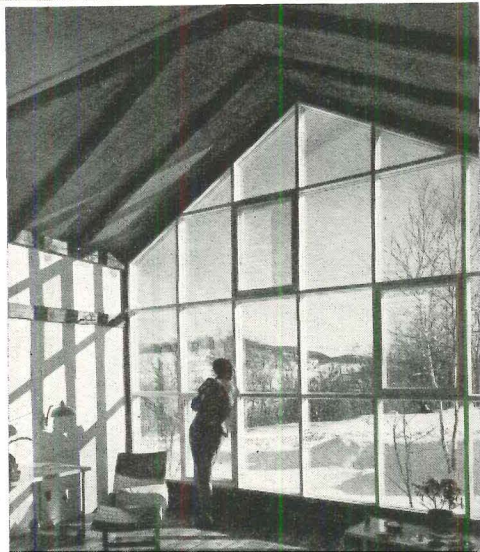

Living room has several opening sash units in glass gable end, might have had many more if necessary.

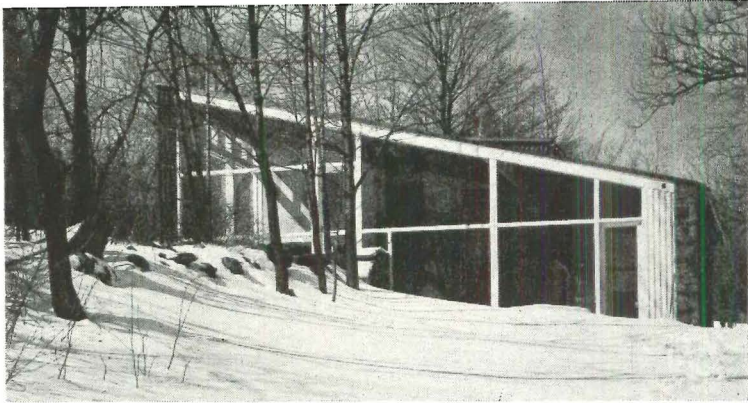

Rudolph E. Lippert, Jr.

Shed-roof house in Central Valley, N.Y., by Jackson & Callender, architects, has glass fill-in for irregular end wall.

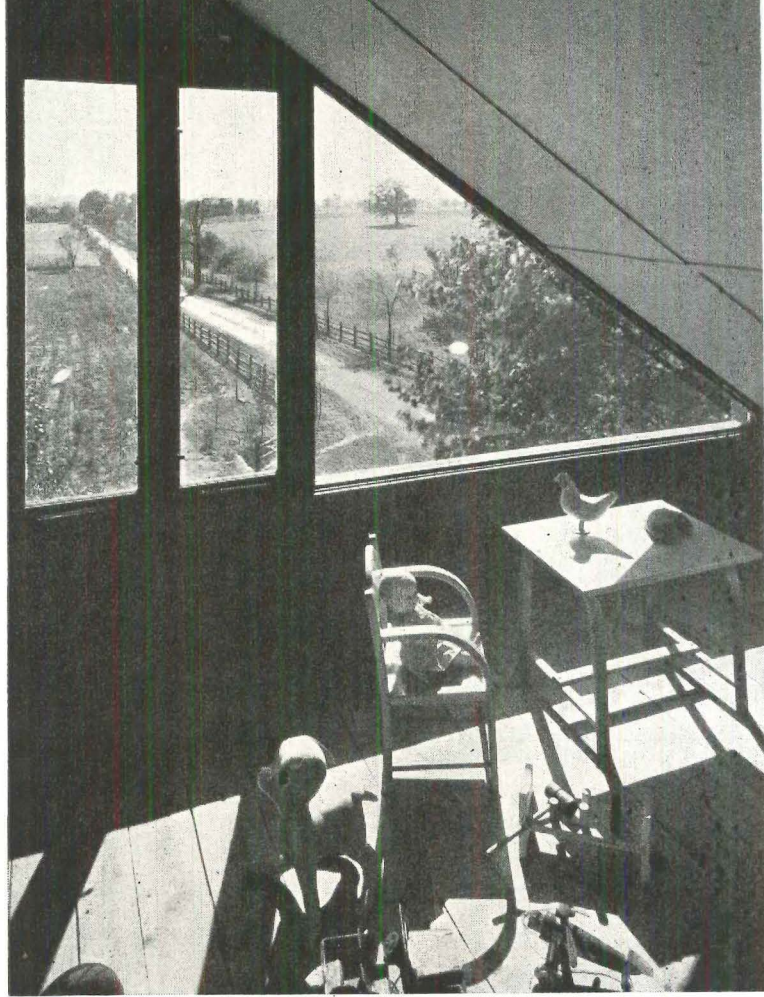

Remodeled Pennsylvania house by Hugh Moore, Jr., (right and below) has attic playroom lighted and ventilated with glass gable end.

Photos (below): Charles R. Pearson

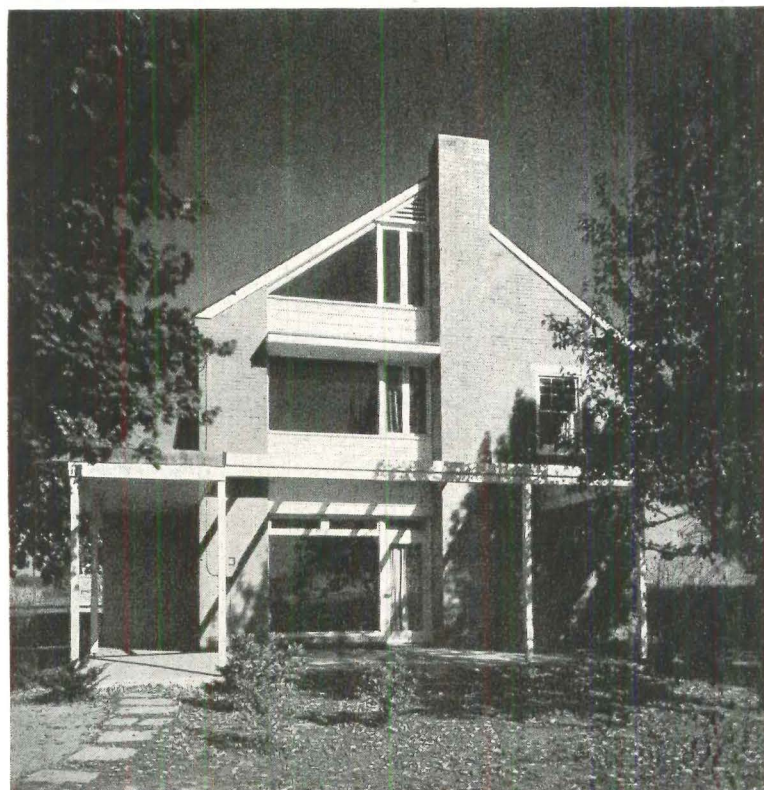

Photos (above): Ben Schnall



In Seattle, architects Young & Richardson incorporated ventilating louvers in their glass gable end (left and above). Still a problem in this design idea: How to pull curtains across the entire glass wall.

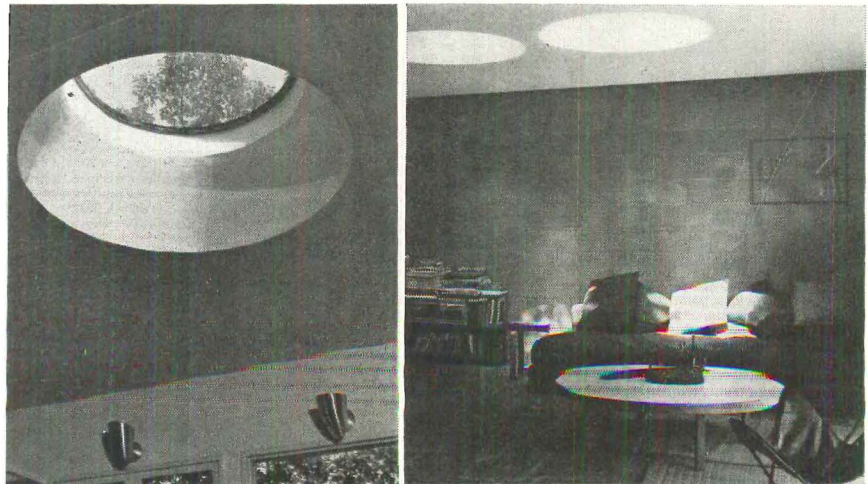

Three plastic bubbles provide daylighting for the interior of the living room in house designed by The Architects Collaborative.



North end of Architect William Hempel house gets benefit of sunlight through skylight set between roof joists.

2. Holes in the ceiling

Builder's problem: How to light the dark center of a generally square house, and how to make that center area really count?

Architect's suggestion: To lighten dark corners, architects are coming up with some new variations of the old-fashioned skylight. Complete plastic dome units—originally designed by The Architects Collaborative for their Six Moon Hill Houses—can now be bought by builders. The domes are set into metal frames designed to fit into standard joist spacing. A lower cost method, used in a house designed recently by Architect William Hempel (picture, above), is to set sheets of plate or wire glass directly into the spaces between roof joists. This is an on-the-spot operation especially well adapted to low-pitched or shed roof lines.

Mirrors add to sense of spaciousness in houses by Hugh Stubbins (right) and Richard Neutra (below).

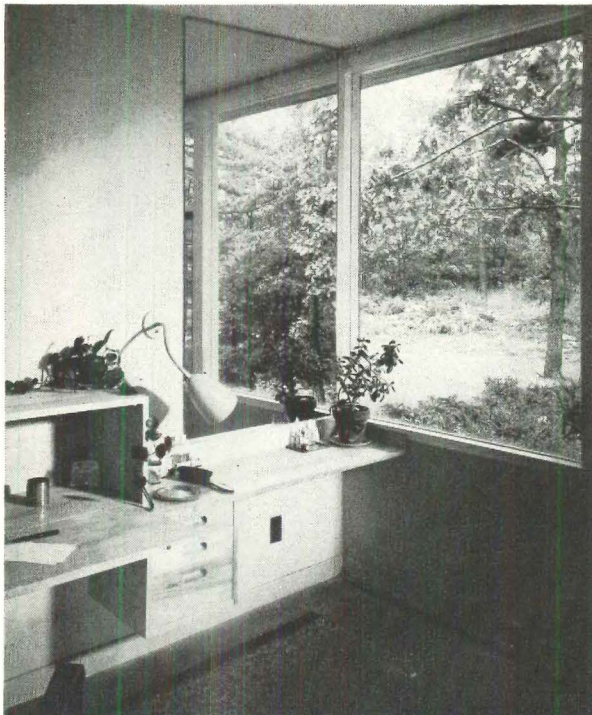

3. The mirror trick

Builder's problem: to provide an illusion of greater spaciousness in the small rooms of today's house.

Architect's suggestion: Top-flight architects have taken an old space-illusion trick—the use of mirrors—and added a new wrinkle. They are placing the mirror at right angles to and flush with the windows of their small rooms. In so doing, they achieve the dramatic, and practical, effect of bringing the outdoors inside. The two examples shown here, designed by Architects Hugh Stubbins and Richard Neutra, are located in bedrooms where the mirrors serve also as part of a vanity table. There is no reason, however, why this low cost variation on the old mirror trick cannot be applied to other rooms.

Photos: Roy McCann; Roger Sturtevant; Ezra Stoller Pictor; Julius Shulman

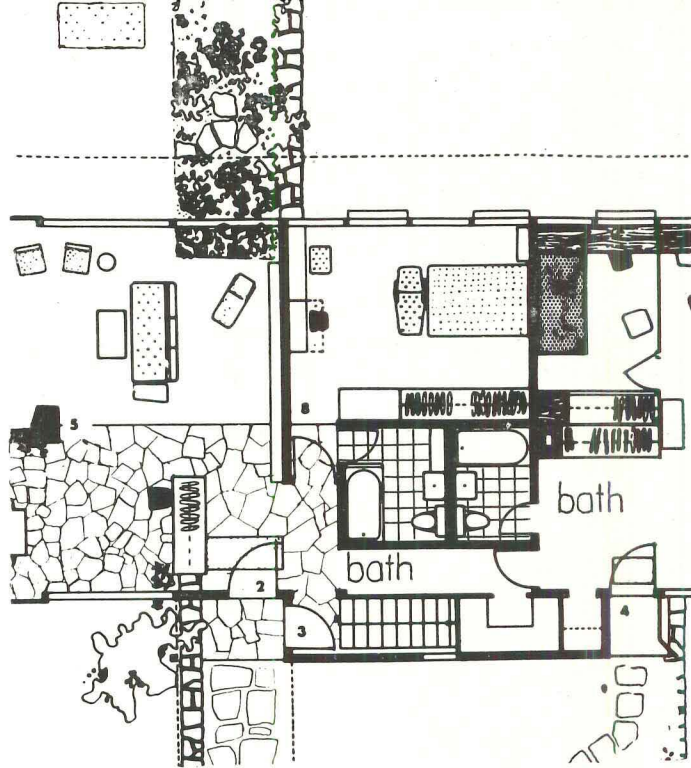

Architect Hugh Stubbins' own house in Lexington, Mass. (above, left and below) has two interior bathrooms with sky-lights, wastes no valuable house perimeter where privacy is desired.

4. Interior bathrooms

Builder's problem: How to make the best use of the perimeter window areas of a small house and how to make the best use of the windowless space in the center.

Architect's suggestion: The bath is one room where privacy is more important than a view, so instead of building a perimeter bath with high or frosted windows, why not put the bath in the center of the plan? In a one-story house, it can easily be ventilated and lighted through a skylight. That will leave all the perimeter free for more windows in the living room, kitchen and bedrooms.

Builders have been too slow in picking up this idea, excellent examples of which are found in Architect Edward Stone's 900 sq. ft. LIFE model house (below).

Twelve years ago architect Edward D. Stone designed square builder's house (below) with interior bath for LIFE Magazine. Skylight provides excellent light and fresh air.

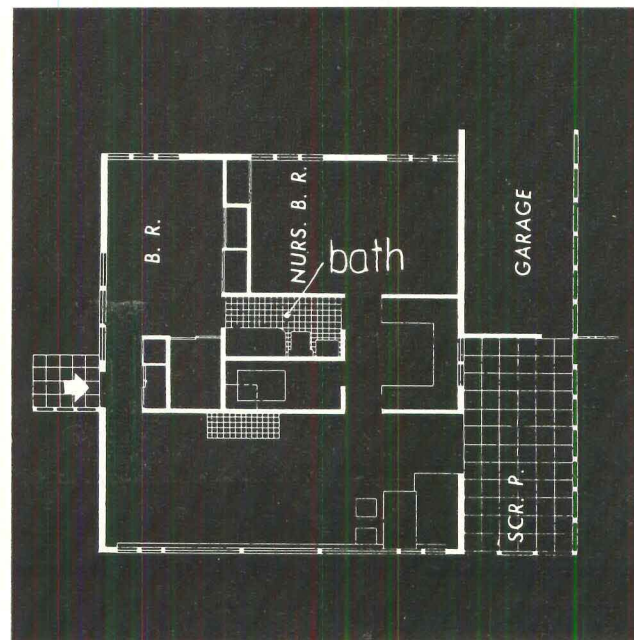
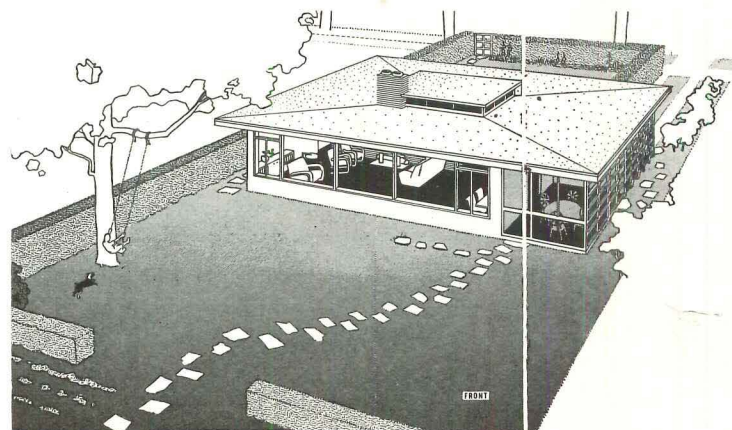

THE DINING AREA PROBLEM

In today's tiny houses, there is no room left for a special room just for eating. The dining room, as such, has become an expensive luxury. Sometimes the dining area has been absorbed into a slightly larger kitchen. Sometimes it has shrunk to an alcove at one end of the living room. In the typical small builder's house (800 sq. ft. or less) there is now hardly room for even one of these compromises. Recently, however, architects have come up with some interesting answers to each of them. Four of the best are shown on these pages.

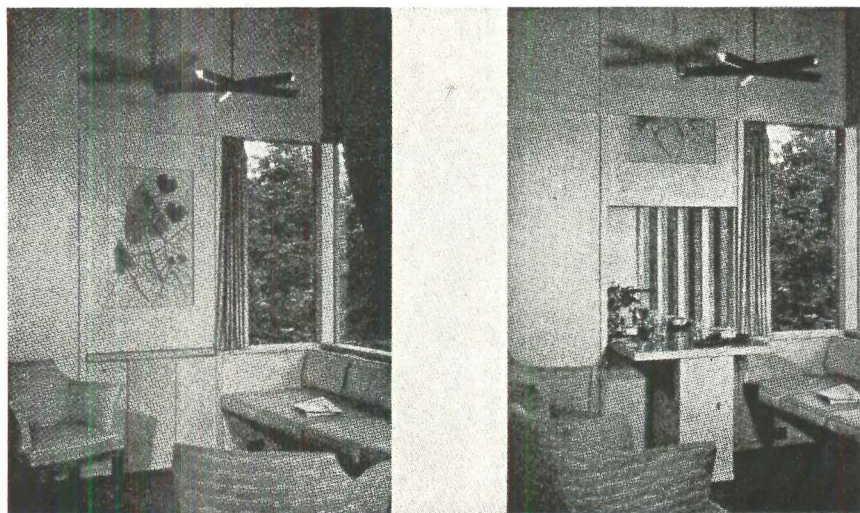

"Vanishing dining table," designed by John Yeon for his own house is flush to kitchen-dining partition when not in use, slides out along window seat for meals.



5. The vanishing dining room

Builder's problem: If the family is to eat in the living room, must one-third of this area always look like a dining alcove?

Architect's suggestion: John Yeon of Portland provides a beautifully thought-out answer with a sliding table that can be pulled back into the kitchen, dishes and all, when the meal is over, leaving no trace of the eating function when it disappears through the wall. (See pictures, above.) Note how in the kitchen the table fits out of the way, flush under the window, while in the living room a bay window provides a seat for the diners.

Architect Carl Koch has made somewhat different use of the same idea in a larger house where his sliding table can serve as an added work area in the kitchen.

6. The eating bar

Builder's problem: Since breakfast and lunch are informal (especially where there are children), what arrangement can be made for making these meals easier to serve?

Architect's suggestion: Make the pass-through from the kitchen serve double-duty as an eating bar. Shown here are some handsome applications of the principle by architects in designing custom-built houses. This idea has been picked up by a few pace-setting builders, should prove a good sales help for many others.

Sliding table between kitchen and living area designed by Architect Carl Koch is more adaptable for larger kitchens, where there is room for a free-standing table.

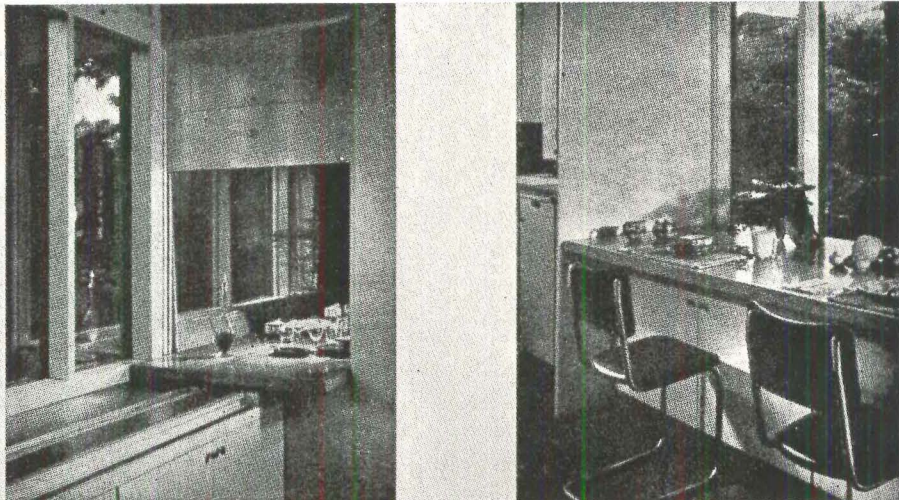

Additional kitchen work surface is provided when dining table is rolled back after meals. It also doubles as snack bar for informal meals.

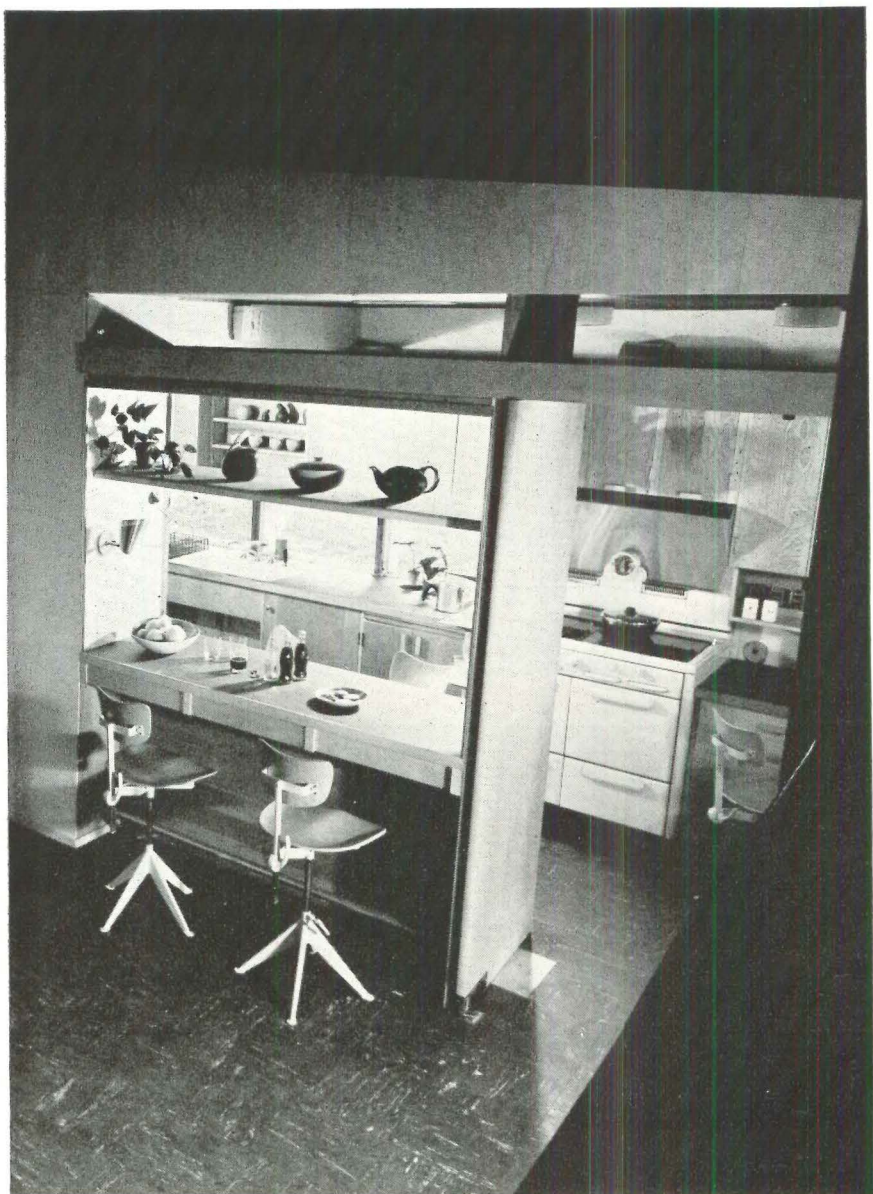

Eating bars by Walker Art Center architects in Minneapolis (left), Edward D. Stone in New York (above), and Gordon Drake near San Francisco (right) show variations on the same theme.

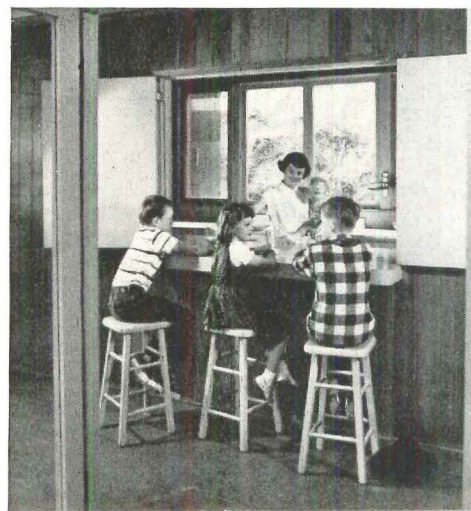

7. The open kitchen

Builder's problem: In small houses, the squeezing process has gone so far that there is hardly room for an adequate living room *and* an adequate kitchen.

Architect's suggestion: Why not revive the old-fashioned living-kitchen of earlier days? Fifteen years ago, when living room decorations meant wallpaper and all kitchens were judged by their percentage of white enamel, the two rooms could hardly mix. Today, the decorator trend in both rooms is the use of color and natural woods. Thus, the decorative schism is less serious. Shown here are some architect-designed houses where the cooking is done right in the living room. The separation between living room and kitchen has been reduced, in most cases, to a partition just high enough to hide the dirty dishes and other meal-time clutter.

The solution is a natural one for opening up the tight living areas in small houses. In an 800 sq. ft. house, the living room is usually no bigger than 180 sq. ft. The kitchen will average 80 sq. ft. By combining the two rooms, a large 20 x 26 ft. kitchen-living area can be achieved.

Chest-high storage partition blocks view of kitchen clutter in California house by Fred Langhorst. Other side of partition shown in picture, bottom right.

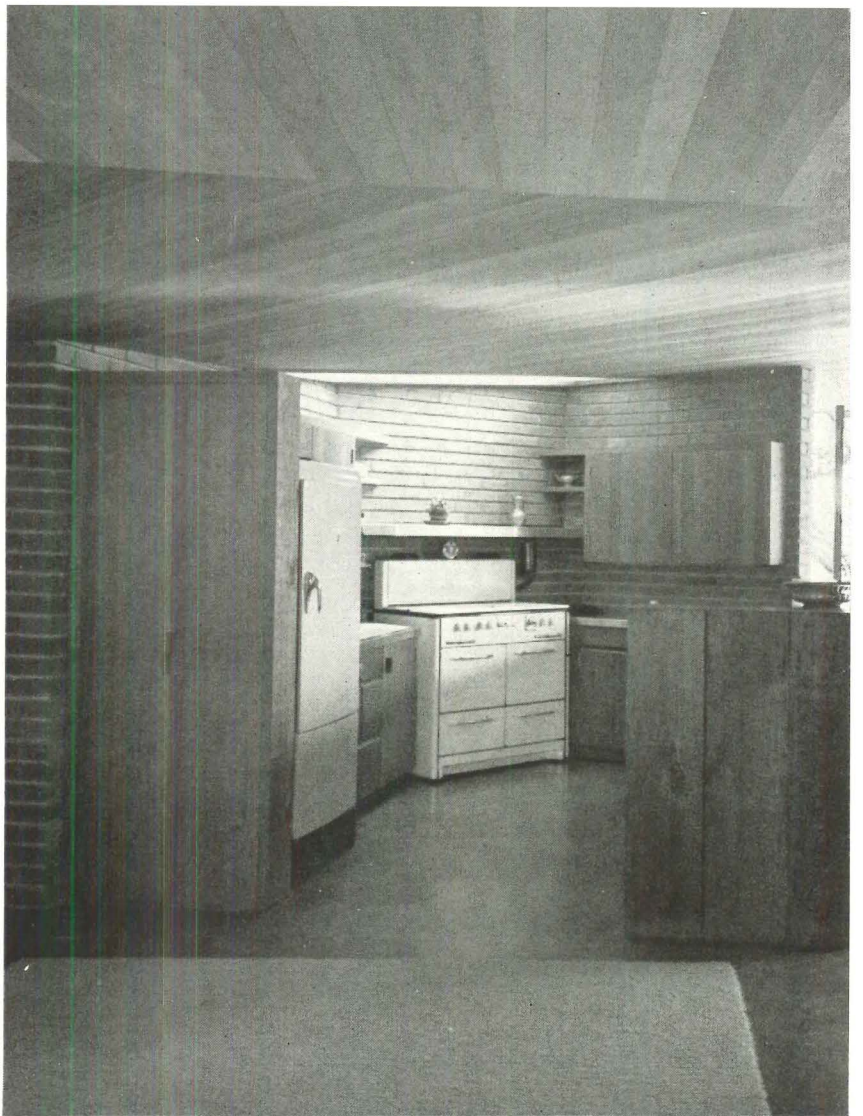

Above, interior kitchen designed by Architects Hillmer & Callister provides added living area around house periphery. Below, living-kitchen room designed by Wurster, Bernardi & Emmons.

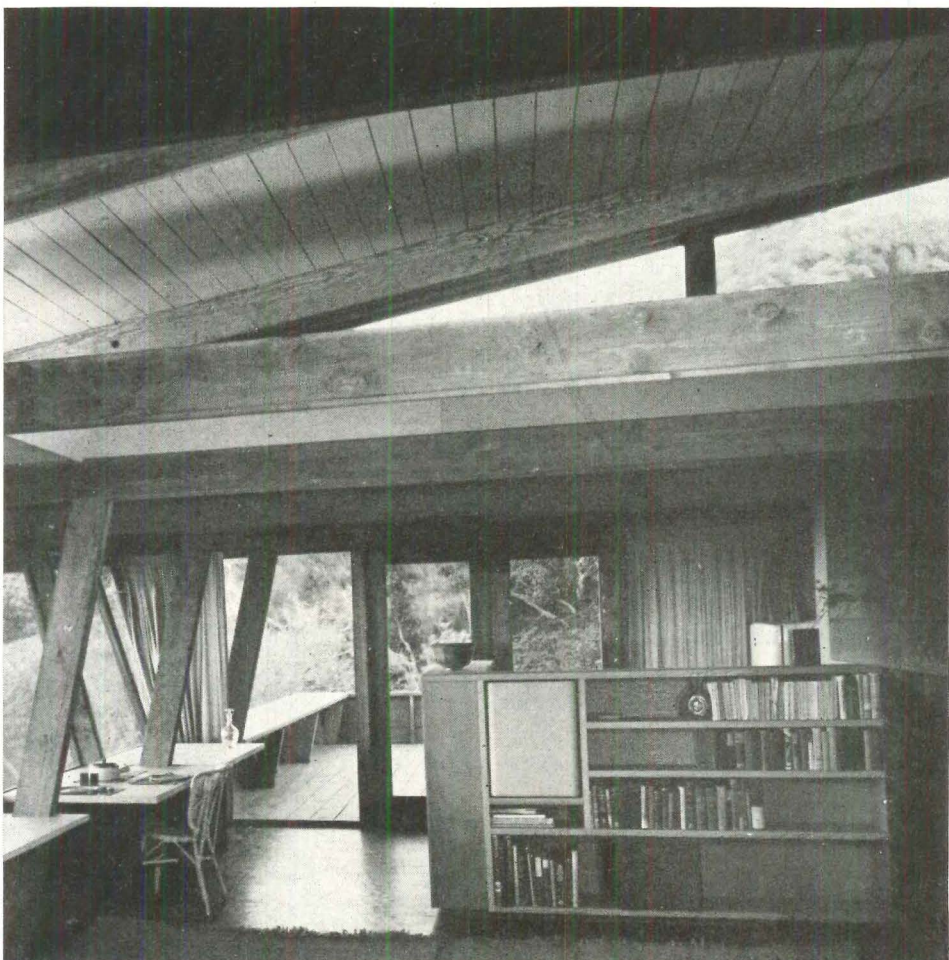

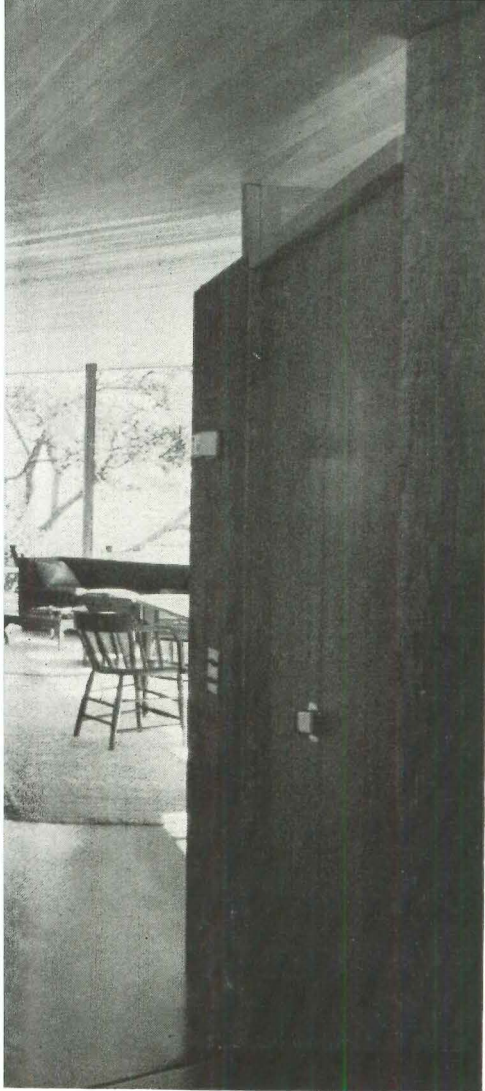

8. The folding kitchen

A second solution to this problem is suggested by Architect Harry Weese who has put the storage wall of his kitchen on rollers. During the housework hours, the wall is kept open as a partition between the kitchen and living area. At night, after the dishes are done, it is rolled back against the wall (see picture, right) so that most of the kitchen floor area becomes part of the living room.

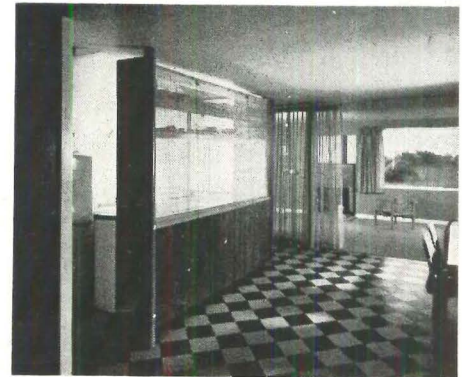

Folding kitchen by Architect Harry Weese (right and below) opens up most of kitchen to living area when cabinet wall is swung shut. Note that refrigerator is not blocked by closed cabinet wall.



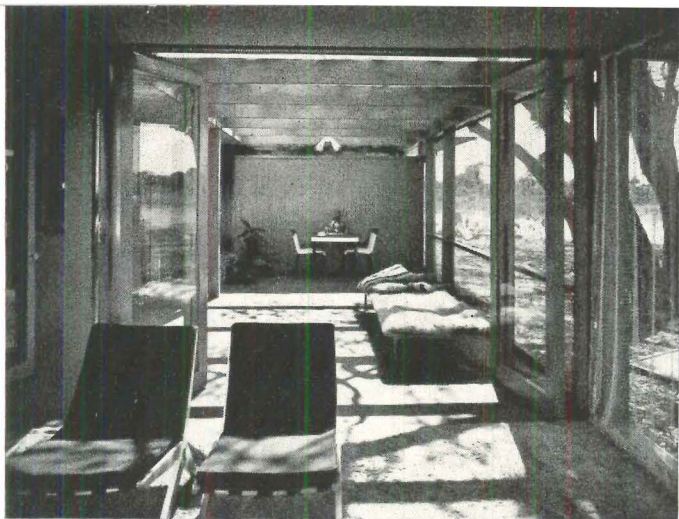

Florida House by Architects Twitchell & Rudolph (above, right and below) has completely screened outdoor living room for almost year-round use.

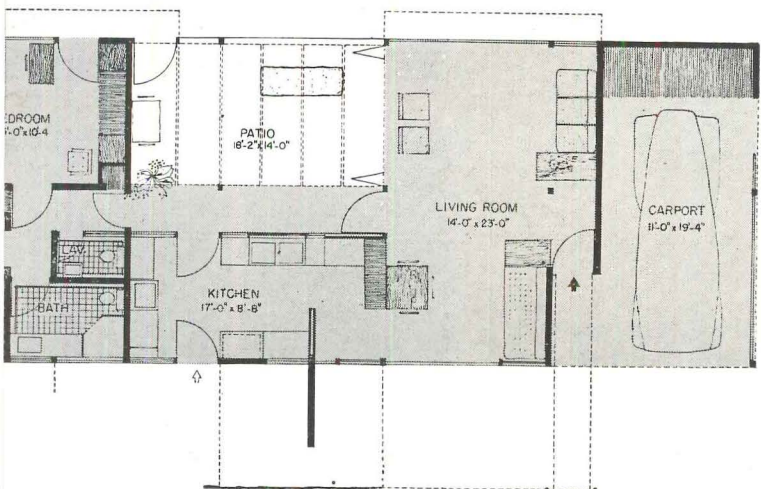

9. The outdoor room

Builder's problem: how can the living area of a house be extended at low cost?

Architect's suggestion: Why not build the house around an "outdoor room"? In a one-story house with a flat or low-pitched roof, this will add less to the overall cost than it will add to the seeming size of the flanking rooms—usually (as the plans on this page show) the living room and the kitchen or bedroom. Other benefits: it will provide a sheltered outdoor space which, with proper orientation, can be used in many months when an open terrace would be too cold; it provides a natural play area for children where they can easily be watched and it gives the outdoor living area almost complete privacy.

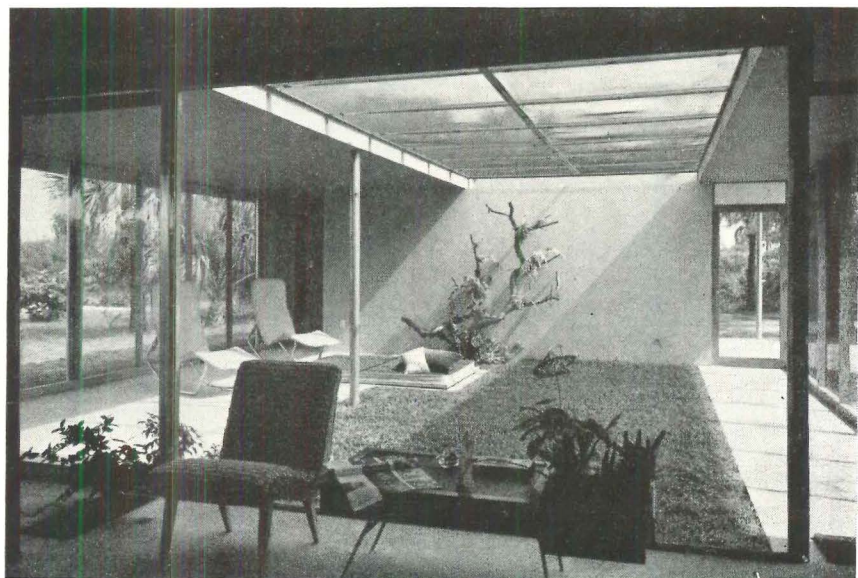
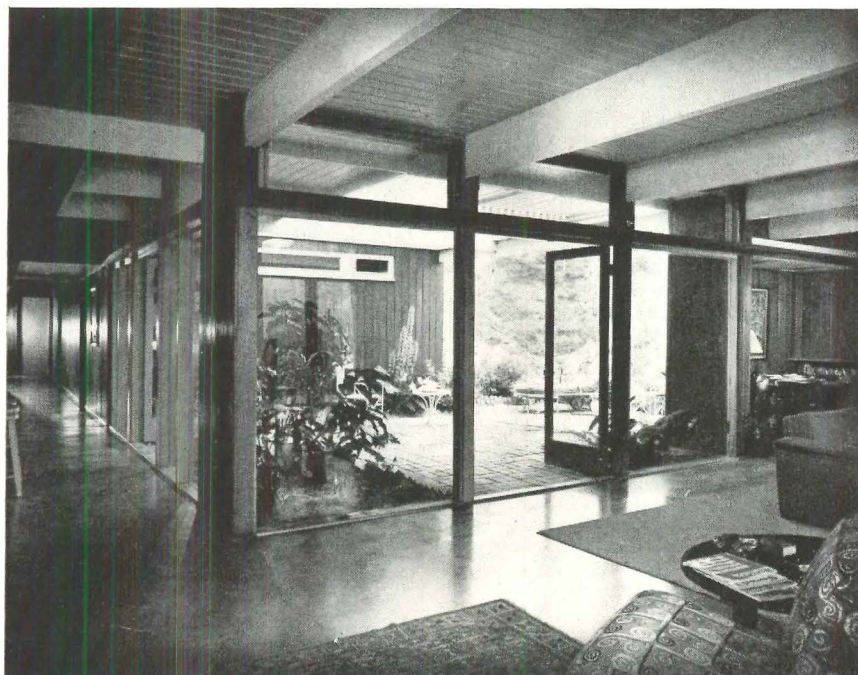

Twitchell & Rudolph's Revere House—also for Florida—has a patio-extension of living room in its center (right). Picture above shows San Francisco house by Architect Gordon Drake with partially covered outdoor living area.

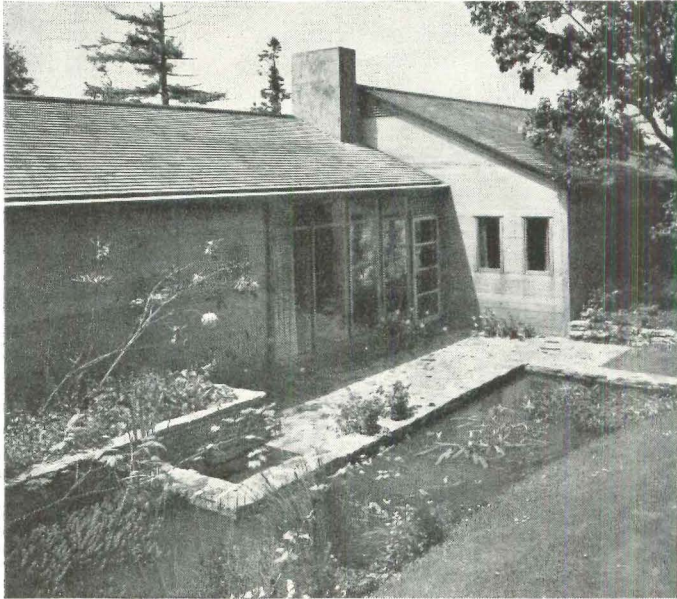

House in Northern California (left) was designed by John Yeon about 10 years ago, uses pools in a terraced setting with fine effect.

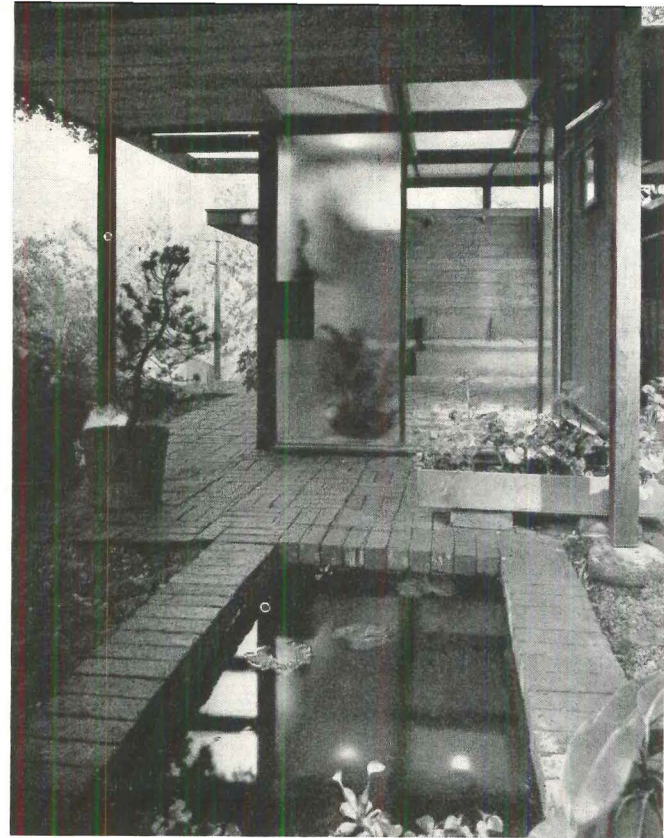

Architect Gordon Drake built a small reflecting pool (above) into the terrace of his own house near Los Angeles.

10. Reflecting pools

Builder's problem: Is there a low cost way to increase sales appeal of a house?

Architect's suggestion: Why not cash in on the tremendous appeal of water? Rich people have always loved reflecting pools around their mansions. Now pools can be built so inexpensively that anyone can afford one. They reflect light, they cool the surrounding area, they can be used to plant lilies or they can serve as a splash pond for children during the summer months.

Here are some examples of the interest some of the country's leading architects are showing in small pools. Realizing that a shallow concrete tub can be poured cheaply and quickly with the foundations, these architects have added immeasurably to the outdoor-living possibilities of their custom-built houses. There is no reason why builder's houses should not have the same advantage.

Important things to remember are: 1) if the pool is to take lilies, it should be 12 in. deep at least. If it is to serve only as a reflecting pool, 2 in. is enough. 2) it must be located where it will catch the sunlight—pools in the shade look dead; and 3) it doesn't need an elaborate drain. An outdoor hose connection—which should be near it—will be sufficient to fill the pool.



Nesbitt House by Richard Neutra has indoor-outdoor pool for planting and reflection. It stands in Brentwood, Calif.

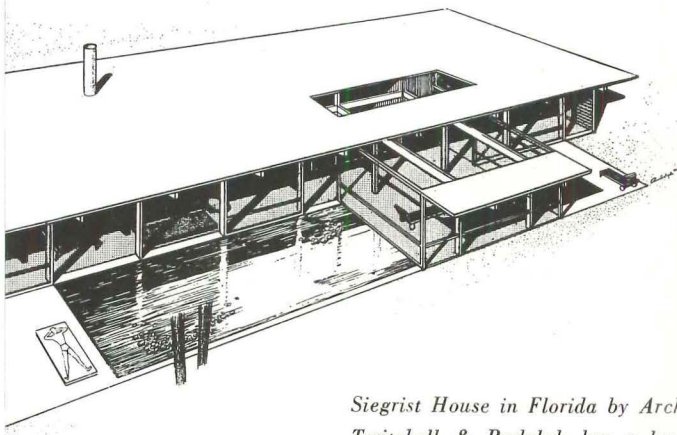

Siegrist House in Florida by Architects Twitchell & Rudolph has a large reflecting pool along one facade (above and right), uses water to cool adjacent porch and for dramatic visual effects.

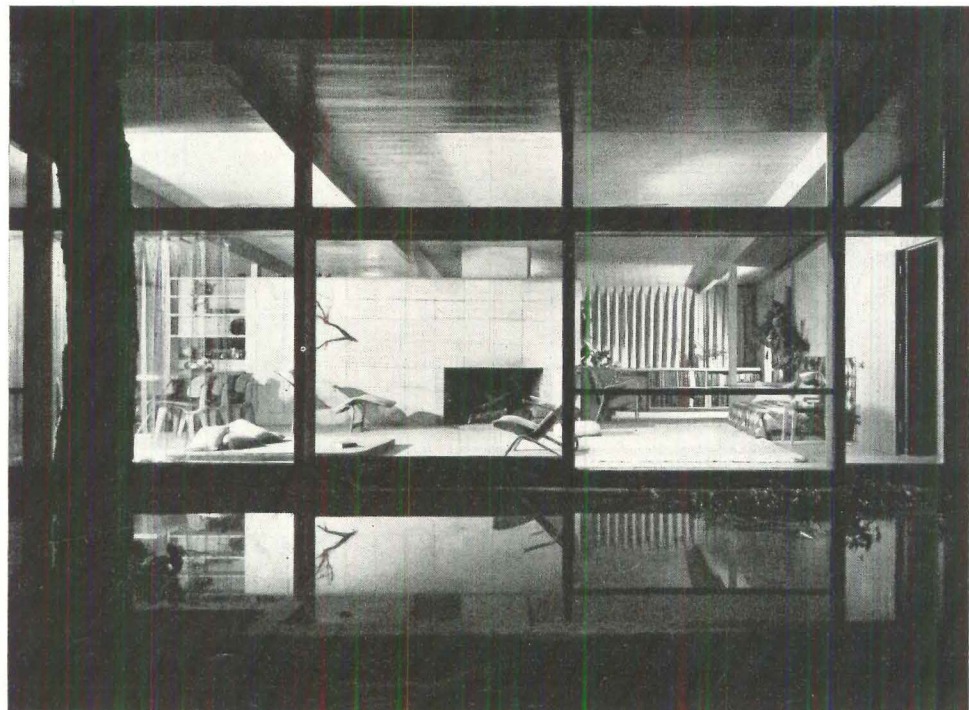

11. The chimneyless fireplace

Builder's problem: To gain the sales appeal of a fireplace without the expense of a big masonry chimney and all the framing, waterproofing and planning difficulties it usually creates.

Architect's suggestion: A chimneyless fireplace. Must a small fireplace flue be encased in tons of brick and mortar? The answer, as demonstrated in these six architect-designed fireplaces, is no. Each unit has a flue but it is such a simple stack that it is completely independent of the house structure itself. One result is that the fireplace can be located wherever it will best fit the living room plan—even tucked under a window or in the middle of the floor—instead of being anchored in some location dictated by the exterior design, the framing, or the second-story layout. Because of their structural simplicity, all the fireplaces shown here can be readily adapted to a mass-volume building operation.

Aside from quick-and-easy installation, these fireplaces are themselves quite inexpensive. Except for the architect-designed prefab unit (below), they were custom-built.

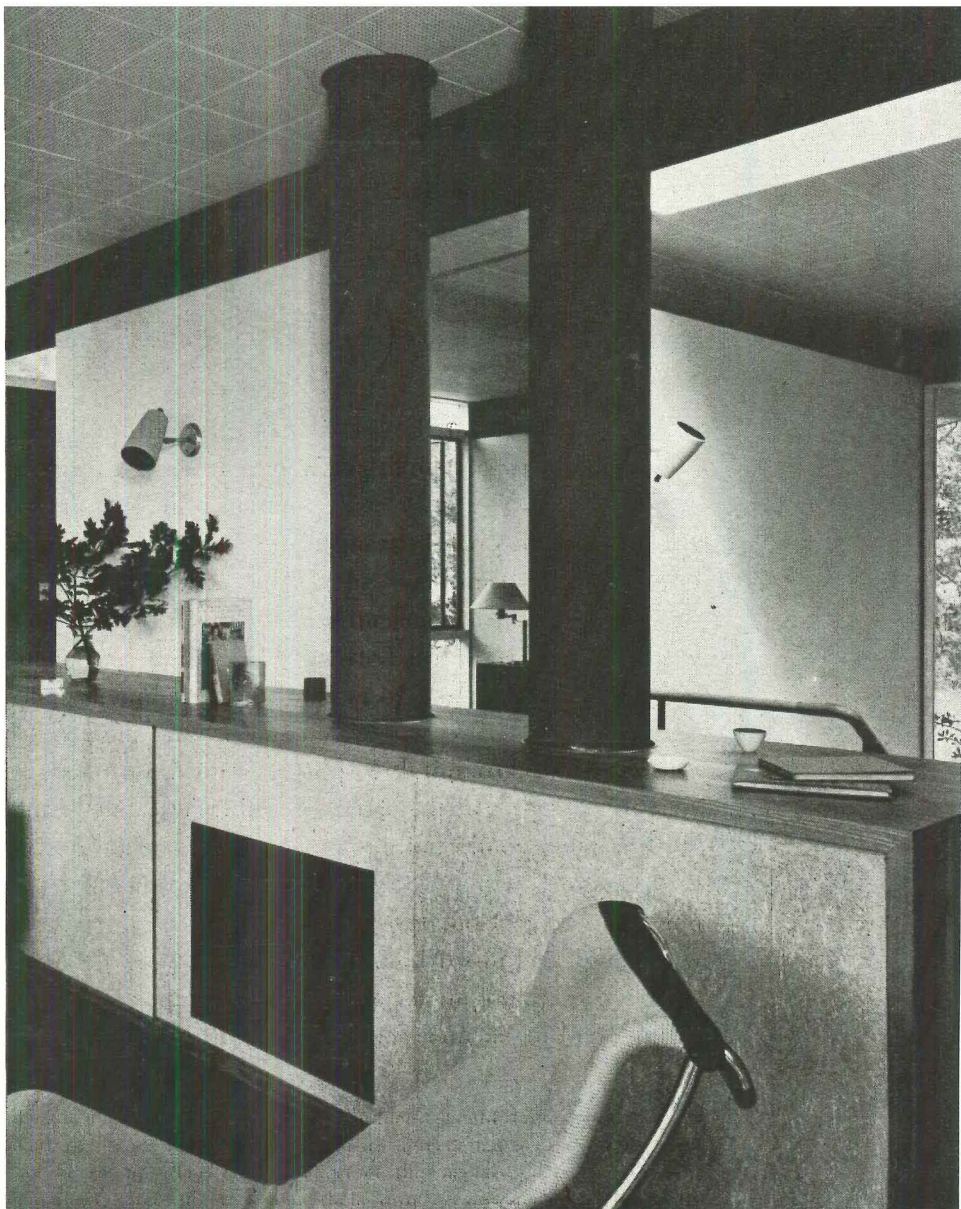

Fireplace in Architect John Johansen's own house is set in low cabinets, has free-standing flue painted bright red. Second flue serves downstairs furnace.

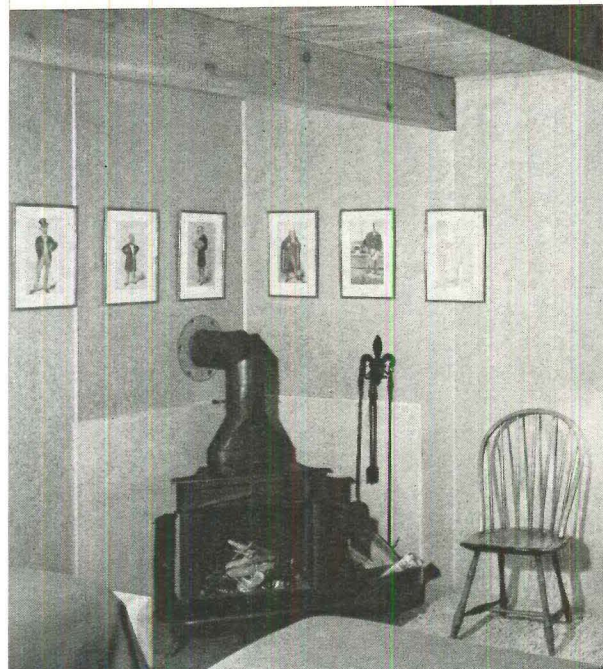

Architects Wurster, Bernardi & Emmons specified old-fashioned Franklin stove for this bedroom.

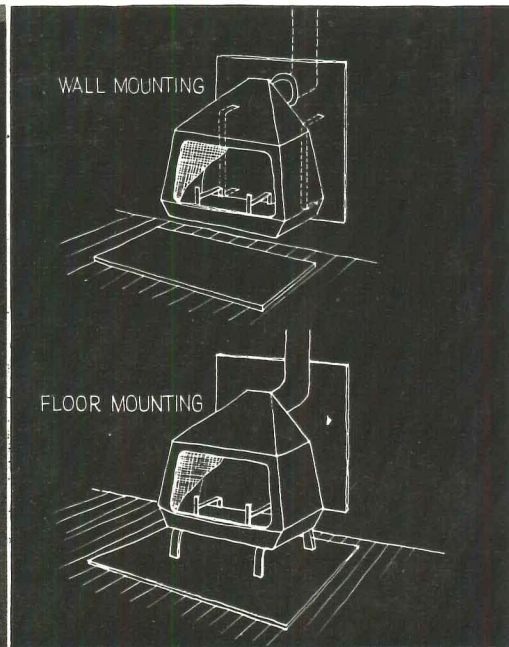

Architect Carl Koch's prefab fireplace is neat, low cost variation on Franklin stove.

Photos: Damora; Roger Sturtevant; Ezra Stoller—Pictor

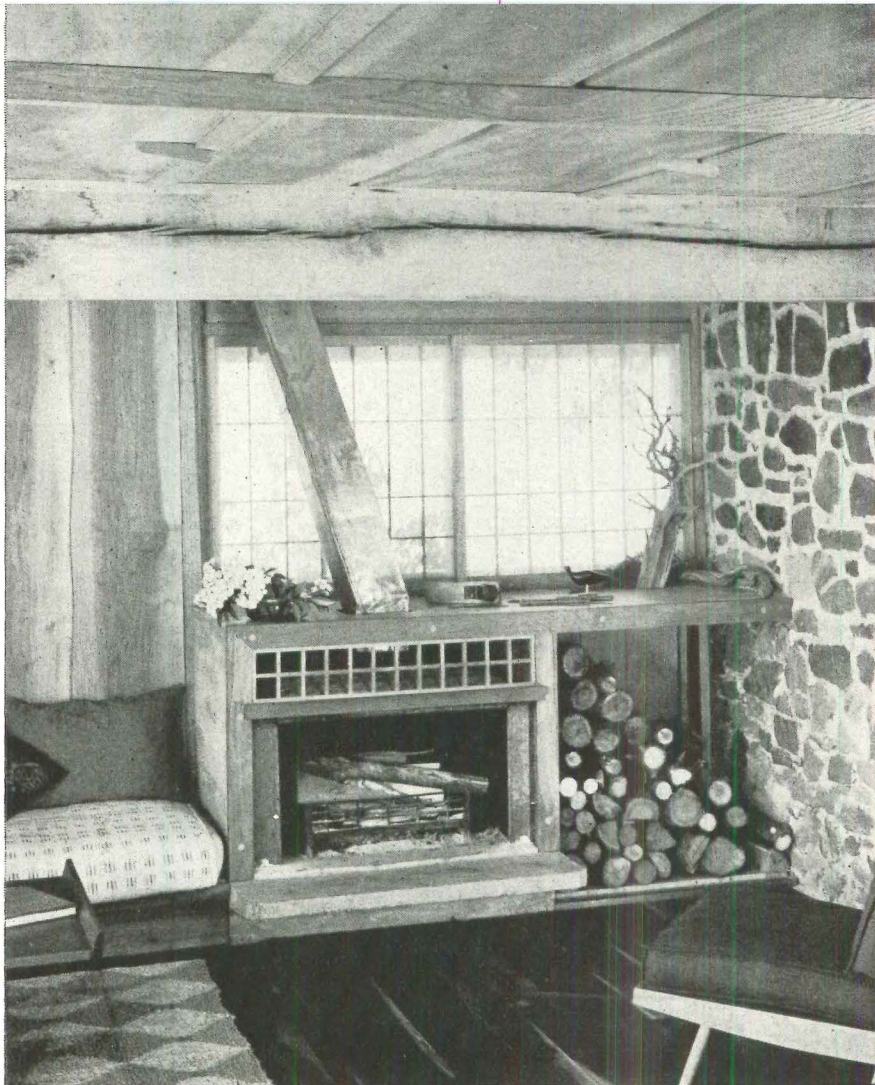

Fireplace under a window was designed by George Nakashima for his own house in Pennsylvania. Flue is made of sheet metal, is tilted slightly to get better updraft.

Photos: Pictorial Services, Inc.; Julius Shulman and Roger Sturtevant

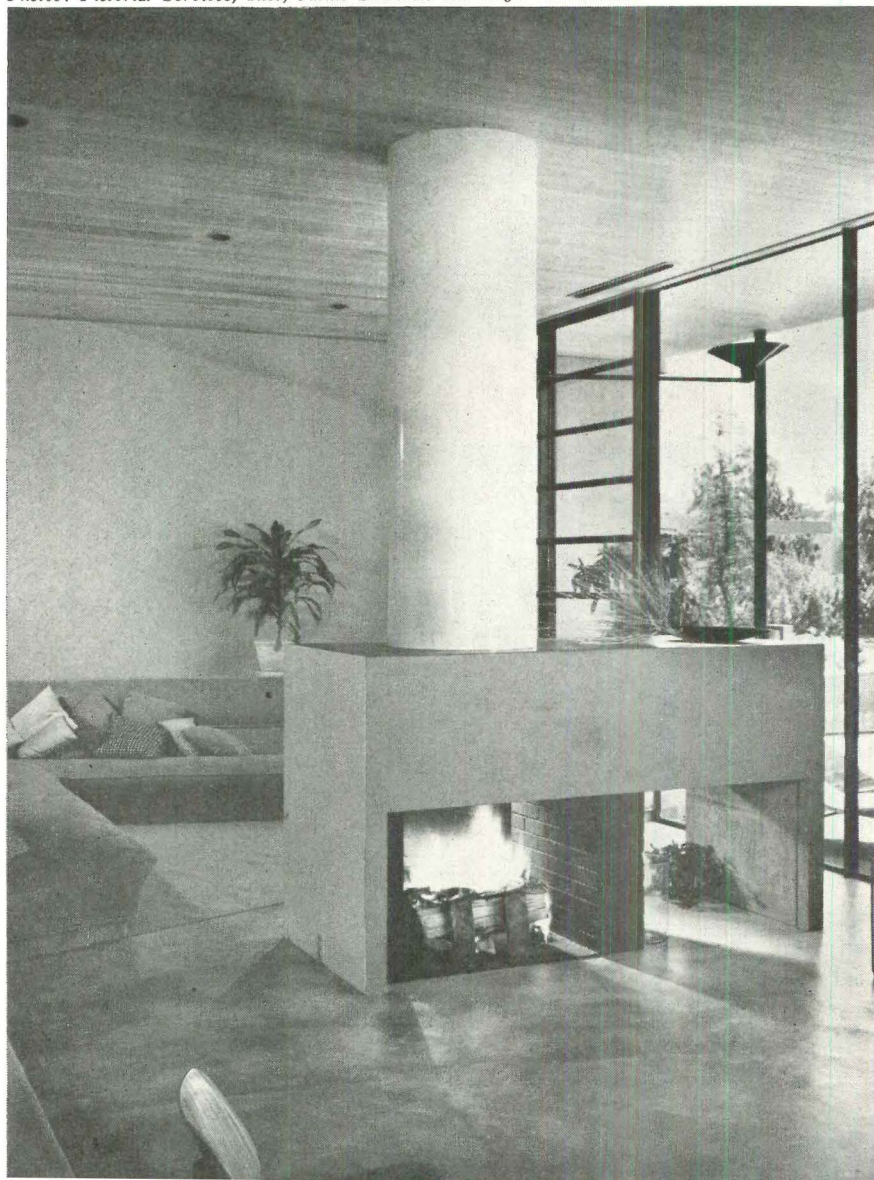

Middle-of-the-room fireplace, designed by Architects Eero Saarinen and Charles Eames, demonstrates clean, open effect that can be achieved with non-masonry fireplace construction. Flue is asbestos board.



Copper cone flue in Architect Albert Frey's own house is also an effective radiator to counteract night-time chill.

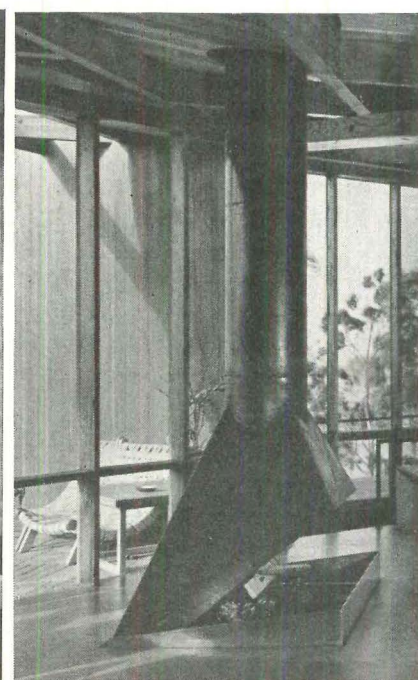

Iron hood and flue in this house by Architect Mario Corbett, is another example of free-standing fireplace construction.

12. Raised fireplaces

Builders' problem: To give added sales appeal to a masonry fireplace by making it at once more dramatic and more functional.

Architects' suggestion: Why not raise the hearth some 15 in. off the floor, making the fire easier to see, easier to lay and tend, easier to clean up after and easier to use for an indoor barbecue?

This is an old idea newly imported from Europe. It can be particularly effective if the fireplace base is continued along the wall as a shelf, as Gregory Ain did in the example below. Architect Alfred Levitt sold his brother Bill on this idea a year ago, and it has proved very popular in their big Levittown, L. I. subdivision.

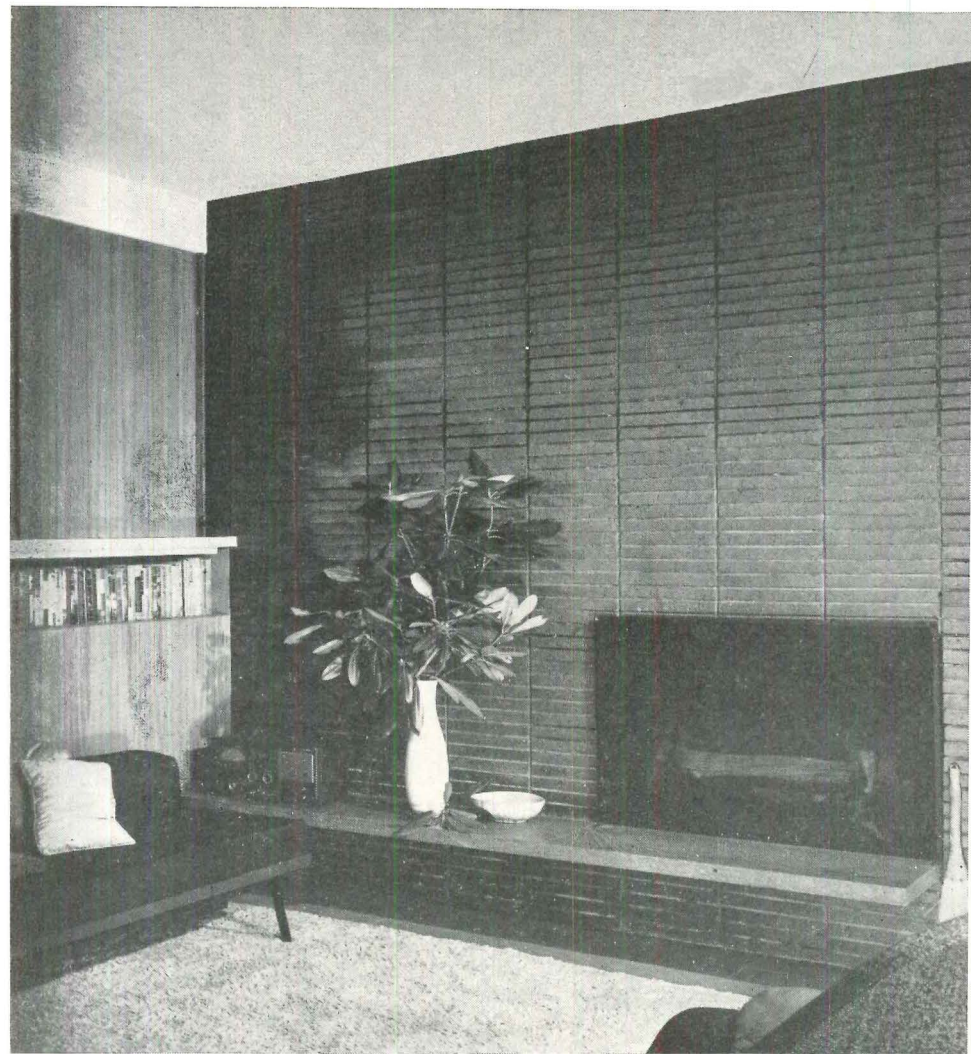
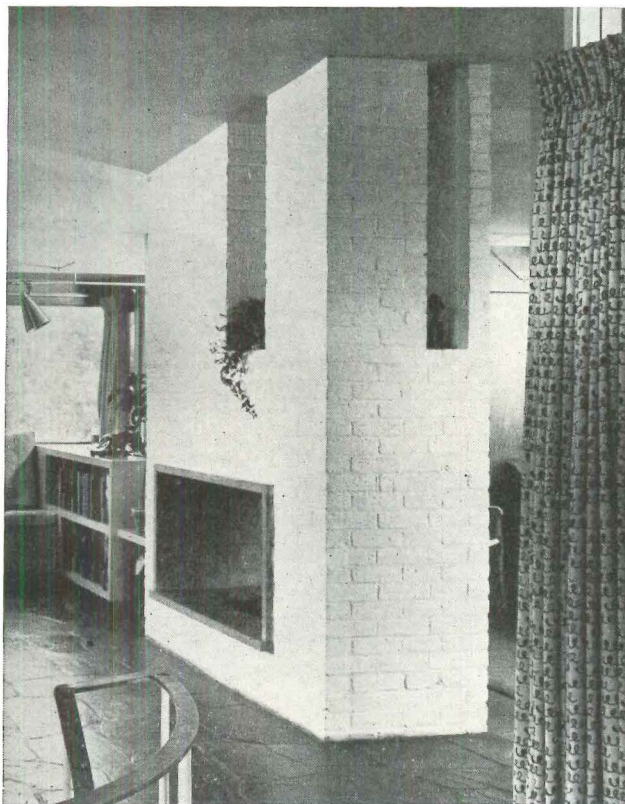
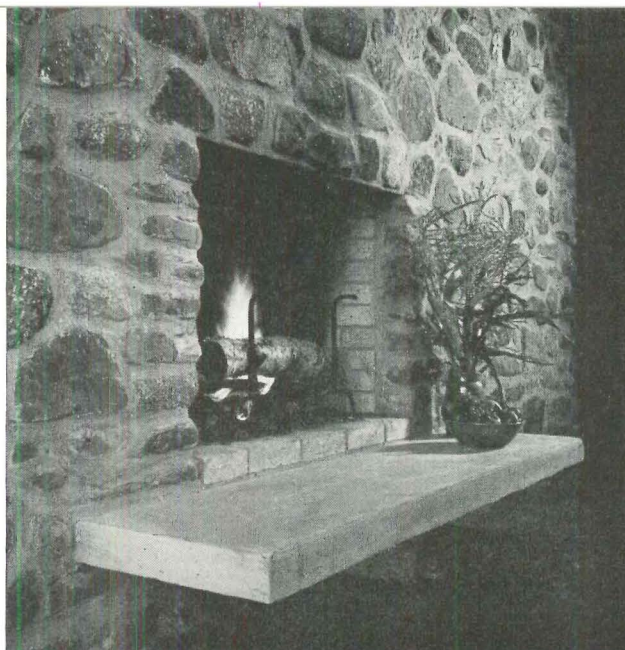

Raised fireplace, above, was designed by Architect Gregory Ain for Museum of Modern Art. Fireplace at right is by Paul Beidler, one above it by The Architects Collaborative and the top one by Eaton W. Tarbell.

Housebuilder BILL ATKINSON

A profile of the man who is slated to receive his industry's top honor and top responsibility—the presidency of NAHB

William P. Atkinson is a lean, lank, twang-voiced builder from Oklahoma City who will probably be elected the 1951 president of the National Association of Home Builders at its annual convention this month in Chicago. It hardly does justice to Bill Atkinson, however, to describe him simply as a housebuilder. More correctly, he is a townbuilder. His first town (there may be others later on) is Midwest City, located ten miles east of Oklahoma City. Since 1943, Atkinson has spent most of his time planting hundreds of flat, wheatfield acres with houses, factories, schools, stores, churches and a jail. His town currently has a population of over 11,000 and new houses are continually popping up around its outskirts like gophers after a windstorm.

Atkinson is, in short, a graduate *cum laude* of the make-no-little-plans school. And Midwest City is only a symbol, albeit a spectacular one, of the extraordinary qualifications which he will bring to his new NAHB job. Item: he is the ablest politician in the housebuilding field—so able that he is a good bet to be Oklahoma's next governor. Item: he is a first-class organizer and executive, directing 43 of his own corporations with deceptive ease. Item: he has pioneered many of the ideas which are just now being grasped by the rest of the industry. He has been prefabbing for years. He was one of the first builders to use the services of a top-flight community planner. He promoted architect-builder cooperation in Oklahoma City a full four years before NAHB and the American Institute of Architects took up the idea.

Thus NAHB's 1951 president is a prime example of the new type of businessman-builder who has changed house construction from a craft to an industry in the past decade.* Only a few years ago, the average U. S. house was built by a carpenter-foreman who had a good year when he turned out five units.

* As are several of his predecessors in the NAHB presidency: Miami's Tom Coogan (the outgoing president), Los Angeles' Fritz Burns, San Francisco's Dave N. Bohannon, Chicago's Nate Manilow and Joe Merrion.



Photos (except p. 170): A. Y. Owen

Last year's 1.3 million unit production was handled largely by merchant builders who often counted their production in the hundreds. Atkinson and the other new builders are essentially administrators. Their emphasis is on production efficiency and smart merchandising. Their goal is to stabilize housebuilding at a steadier, higher level during the Fifties than ever before—international conditions permitting.

The Carthaginian's Oath

It was the unsteadiness of the housebuilding business that prompted Atkinson at the age of nine to take an oath against ever having anything to do with it. His father was a house carpenter in the east Texas town of Carthage. Business was irregular—so much so that the Atkinson family often missed meals. Says Bill: "I decided that any business at the mercy of so many bad breaks was not for me." However, he stayed in Carthage, working for his father and also as a printer's devil, until he was 18. Then, like many another cowtown boy, he packed off to see the world—or at least Texas.

His first stop was Ft. Worth where he wanted to attend Texas Christian University. "I rode my first street car, used an inside toilet for the first time, and registered for college all in the same week," he recalls. Atkinson was graduated from TCU in 1924 not only with honors but also with a considerable bankroll. The money was his reward for four years' work as business manager of the college newspaper. At the time, the paper was being run by a dedicated group of English Lit majors who had let the business end of the paper shift for itself. When Freshman Atkinson arrived, the shift was perilously in the direction of bankruptcy. Within a year, he had the paper riding so high financially that he made a deal with the dean-in-charge for a more direct cut in the profits. The dean, who understood a mutually beneficial deal when he saw one, promptly agreed. Atkinson cleared \$4,000 for himself in his sophomore year alone. One example of his resourcefulness



is still remembered. When he found it hard to sell ads on rainy days (because the merchants' business was bad), Atkinson bought a yellow slicker and embellished it all over with the names and slogans of the stores whose ads he wanted. Then he made his rounds, making sure that the manager at each store saw his name before he had a chance to say no to Atkinson. This meant, of course, that occasionally he had to back into the store—an awkward approach but one which produced sales.

After his college successes, Atkinson decided to stick to promotion and got a job as business manager for a string of church newspapers. Most church papers, then as now, suffered under the delusion that editorial piety and good business management could not go hand-in-hand. Atkinson soon changed the minds of a considerable number of Methodist and Baptist editors on this point but eventually even he was grounded by the Depression. Like many another salesman who had basked in the Golden Glow of the Twenties, he found that high-binding sales techniques had their limits when no one had any money—a condition he shared at the time with the majority of his fellow-Americans. He rode out the Depression as head of the journalism department at Oklahoma City University.

Five-house builder

Strictly by accident, Atkinson got into the building business in 1936. He and his wife had wanted to build a home for themselves. When they started talking to builders Atkinson was appalled by their merchandising methods, promptly decided that he could do a lot better and made an arrangement with the builder of his house to sell other houses for him. Within a few months, he was selling two houses a week—all the firm could handle. Later, when the builder was taken ill, his hustling young salesman got the chance to take over the business.

"In those days, it was a job to sell a house," he recalls. "I issued payroll checks on Friday night, then spent the weekend trying to sell the houses and collect a big enough down-payment so that I could cover my hot checks on Monday morning. Sometimes I had to sweat out some long Sunday nights convincing a reluctant buyer to write out a check for my second house." However, he managed successfully to get over each Sunday night crisis and soon he was building five houses a week.

From the beginning, Atkinson was noisily promotion-minded about his houses. He spent months trying to think up a good,

catchy slogan. "Finally I realized that the only thing I wanted people to say about me was that I built a good house. So my slogan was: Bill Atkinson builds good homes." He spread it through newspapers, on billboards and in neon letters across his sales office which was conspicuously located on the most heavily traveled street in Oklahoma City. In 1940, the city building records showed that he was the biggest builder in town. Atkinson advertised his new status for weeks. Next year, the records showed that he was the biggest builder in the state and he changed his ads accordingly.

Birth of a town

Atkinson's biggest break in building came in the Spring of 1942 when the Air Corps announced that it was planning a large permanent depot near Oklahoma City. Atkinson, and every other builder in town, realized that a housing development near the new base could be a gold mine and he was frantic to find out where the depot would be located. The Air Corps said that it needed a plot with the following specifications: within 15 miles of the city, on a railroad, near a main highway and at least three miles from any oil wells. It also announced that it already had an option on the site it considered most desirable.

Atkinson was the first to realize the importance of that second announcement. After marking out on a real estate map all the farms that met the first four requirements, he set out in his car to find a farmer who would not sell his land. That, of course, would be the tipoff that the land was optioned by the Army. For two weeks Atkinson traveled up and down the roads without luck. Every farmer he met was all too eager to sell. Finally, he headed out to the southeast end of town which, by common consensus in Oklahoma City, was the least likely place for an air depot. But Atkinson found someone who wouldn't sell. "Come back in six months and maybe we can do business," said the farmer. "He couldn't have made it any plainer," Atkinson points out, "if he had come right out and told me the Army had optioned his land." He had discovered his promised land across the road at \$100 an acre. Mentally, he started carving up the wheatfields into 60 ft. lots.

The next problem was to buy the land without raising suspicions. Fortunately most of it was owned by one man—a grizzled old veteran of the Oklahoma land rush named Frank Trosper. Atkinson rushed downtown to Trosper's office and, with a great show of nonchalance, asked if he could buy ten



Shopping center dominates main entrance to Midwest City



Handsome offices for himself and his organization are part of the big shopping center. Above, Atkinson strikes an executive pose in his own office.

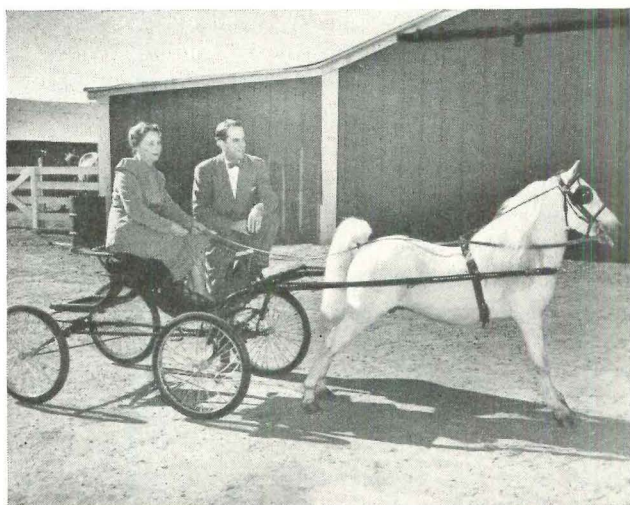

Shetland ponies are Atkinson's chief hobby. (He has 173 of them.) Above, he and his wife Ruby show off a prize stallion, Romeo White Cloud.

acres of farmland out on Route 29 near the county line. Trospser seemed agreeable and, in a few minutes, Atkinson had raised his bid to include most of the 160 acre tract Trospser owned. A contract was typed out and both men signed. Atkinson turned to leave the office ("before I burst") when Trospser called him back: "Young man, you think you slicked me but I'm the one who slicked you. You think that the new Army base is going to be built out there and you're wrong." At this, Atkinson's composure left him. Both men laughed, then sat down to discuss the pros and cons of the location of the new depot. Atkinson left, still convinced he was right. A few days later, the Army announced that the depot would be located across from his new property.

Atkinson wanted to start building immediately. Because he was operating in an important defense area, he applied for 400 housing priorities. By a fluke, he was given 700—the entire allotment for the Oklahoma City area. The air was soon heavy with the howls of other builders. Before they could organize against him, Atkinson invited every builder in town to join in the building of his project. With only two exceptions, they agreed. The 700 priorities were split up according to the relative size of each builder, including Atkinson. And what was originally intended to be a temporary arrangement has since become permanent. Atkinson is, then as now, the only developer in Midwest City but the housebuilding continues to be a cooperative operation. During the past year, Atkinson's organization built less than half the 600 houses constructed there. The rest were built by a dozen builders.

Most of the local builders regarded Midwest City as a defense-housing project that would peter out as soon as the war was over. Not so Bill Atkinson: he announced early that he intended to build a town. He called in Land Planner Seward Mott, asked him to lay out a complete city plan. Says Atkinson, "It was the smartest thing I did because it gave me the pattern for a whole city, which is what I wanted." (Last month, NAHB announced that the project had won its 1950 development planning award.)

Non-stop operation

Midwest City is probably the only major World War II defense housing project which is still under construction. When Tinker Field was cut down to a minimal operation after the war, Atkinson kept right on building houses, despite the warnings of other builders that people wouldn't move ten miles out of town. He was sure they would, especially with the added come-on of shopping centers and other community facilities which he was integrating into the project. Midwest City's biggest merchandising argument is that every house is "within walking distance of a store." The stores in most cases, are small groceries which have been spotted among the houses. They supplement a large, 43-store shopping center which Atkinson has been developing for the past three years at the entrance to his town.

Besides stores, Midwest City has four grammar schools, 10 churches, and six factories which are located in an industrial belt along a feeder-line railroad which bisects the town. The factories are all small, light manufacturing plants, employing very few Midwest City residents. About half of the town's breadwinners commute into Oklahoma City, the rest work at Tinker Field across the highway. Atkinson hopes to change these proportions by making his industrial area a significant job source for his housebuyers. (If he does, he will have accomplished what the planners of satellite towns have been attempting, unsuccessfully, to prove for 40 years, namely to

(Continued on page 164)

PACE-SETTING 1951 SUBDIVISION

Builder's team of architects, engineers and land planners produces model 250-family community of custom-quality \$16,600 houses by using cost-cutting contemporary techniques

LOCATION: Morristown, N. J.

GEORGE NEMENY and A. W. GELLER, Architects

EDWARD S. KLAUSNER, Engineer-Builder

BRYAN J. LYNCH and DONALD L. KLINE, Site Planners

PETER W. BRUDER, Consulting Engineer

Hot war, cold war or garrison state, this development is a fine example of how teamwork between architect, engineer and builder can add to livability and subtract from costs. Here a smart combination of builder's know-how, professional planning, mass production methods and good contemporary design has achieved such outstanding features as:

1) *An imaginative site plan that follows the contours of the lot, preserves existing trees and streams, provides ideal traffic circulation, and gives each house proper orientation, a different look, and a good view. (Opposite.)*

2) *Half-acre lots whose cost is offset by eliminating unnecessary sidewalks and curbs and reducing street widths. (Opposite)*

3) *A wide-open floor plan which combines living, dining and kitchen areas in an economical, sensible relationship and uses big windows and sloping ceilings to add spaciousness and reduce cost. (Pages 132-134)*

4) *A simple construction system featuring an above-grade concrete slab, a modular post-and-beam frame, and on-site shop-fabrication of wall panels and storage partitions. (Page 135)*

Located an hour out of New York in tradition-conscious Morristown, N. J., this 250-family project is the biggest venture in advanced contemporary design yet undertaken by any Eastern merchant builder. Behind it are two years' research and planning by a well-balanced team, assembled by Engineer-Builder Edward S. Klausner. A veteran of 20 years in traditional residential work and steel tower construction, Klausner acted on the conviction that 1) the technical skills employed for larger structures can profitably be applied to the small house, 2) discriminating home buyers are turning more and more to contemporary design as the answer to their need for better living space at moderate cost. The sell out of the first 23-house section within a month and the seal of approval awarded by the Southwest Research Institute have assured Klausner that he is on the right track.

Biggest reason for this sales record is a \$16,600 house which offers amenities usually found only in \$30,000 contract jobs. Designed by architects Nemeny & Geller, this 1,200 sq. ft. house has two good-sized bedrooms, a smaller bedroom-study, two bathrooms, a 12 x 35 ft. basement, a flexible, glass-walled living-

dining-kitchen area, a brick fireplace, a big covered porch and ample ground floor storage space precisely planned for family needs. The purchase price includes a half-acre plot, asphalt walks and driveway, and a garage with storage room. Though only two basic plans were used throughout the development, some 32 simple variations of garage and porch treatment give each house an individual look. Cost: \$12 a sq. ft.

Land planners Lynch and Kline have laid out streets and lots to preserve the wooded, rolling character of the site and provide good orientation for individual houses. A system of curved streets circulates traffic smoothly but safely, with a minimum number of intersections. The plan for the first 75-acre section of the 164-acre tract (opposite page) allocates 5 acres for a shopping center, 12 for streets, 5 for a park around an existing pond, some 54 acres for 105 half-acre building sites.

Preliminary layout of individual houses for best sunlight, view and privacy was made from a study of aerial photographs accurately showing existing trees and other main features of the terrain. Before foundations are laid each house is staked out on the lot according to this preliminary plan and final adjustments are then made by the site planners to preserve trees and improve orientation. The combination of curved streets and squarish plots gives maximum leeway in relating houses properly to their sites and to each other. Most houses will have an unbroken vista of some 400 ft. from their glass-walled living areas. To help owners make the most of their carefully planned property, Lynch and Kline will design landscaping of individual lots for a nominal fee.

Though engineer Klausner's original plan called for one-third acre plots, he is now convinced that the local planning board's requirement of a half-acre minimum make economic as well as esthetic sense. (The board had originally zoned the property for one-acre plots to keep out all speculative building, but changed its ruling when presented with evidence of the Klausner team's painstaking professional approach.) Half-acre plots made it possible to eliminate the sidewalks and curbs required in more crowded subdivisions, saving \$4 per lin. ft. of street frontage. With land costing only \$400 per acre, 140 ft. frontages were cheaper without walks and curbs than 80 ft. frontages with these features. Because of the larger lot sizes, the board also approved reduction of street widths from 50 to 30 ft.: saving: about \$5.50 per lin. ft.

Convinced that the setting and quality of this development make it as good a risk as any conventional type subdivision in the Morristown area, New York's Ninth Federal Savings & Loan Assn. is willing to write 4½ per cent 20-year conventional mortgages covering \$12,000 or 73 per cent of the property's sales price. Since the project was financed before Regulation X restrictions, veterans can buy the houses for \$2,000 down and \$92 monthly.

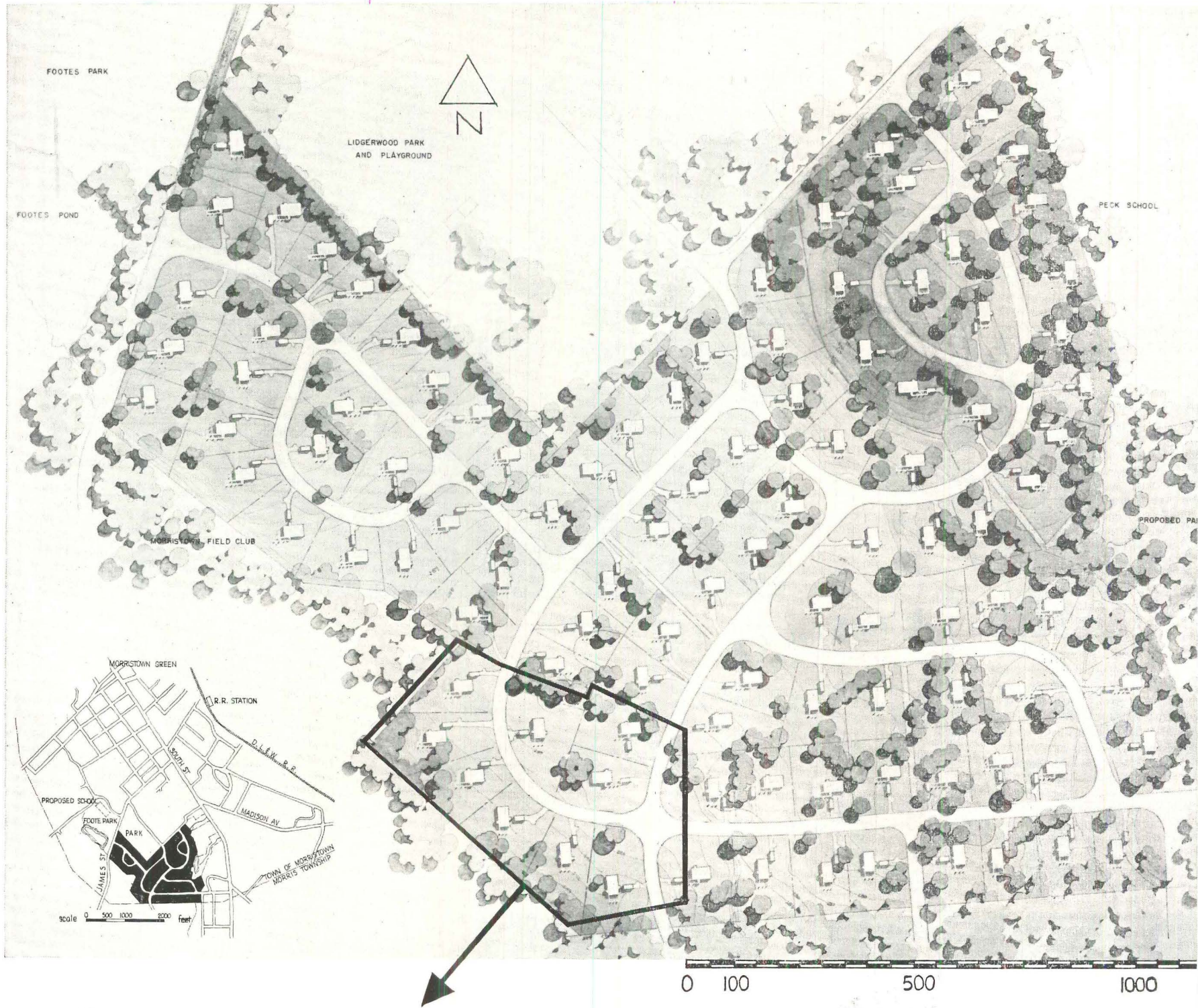

Preliminary site plan (above) was based on aerial photo, established orientation of houses for best sunlight, privacy and use of existing trees and contours. All glass-walled living areas face in a southerly direction. Final plan (left) shows adjustments made on the ground and scheme for landscaping by owners.

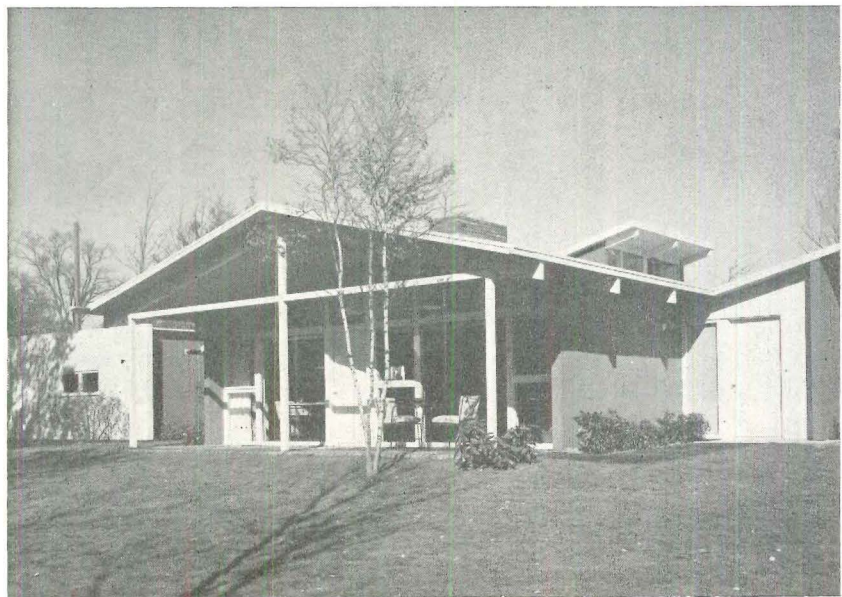
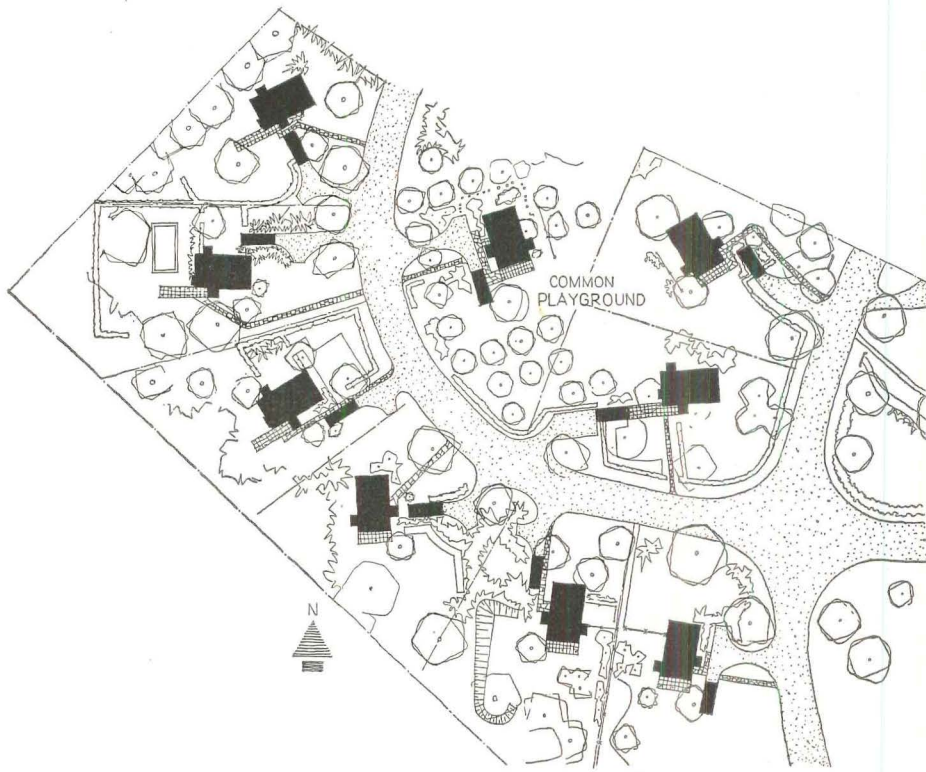

John E. Joyce, Courtesy Woman's Home Companion

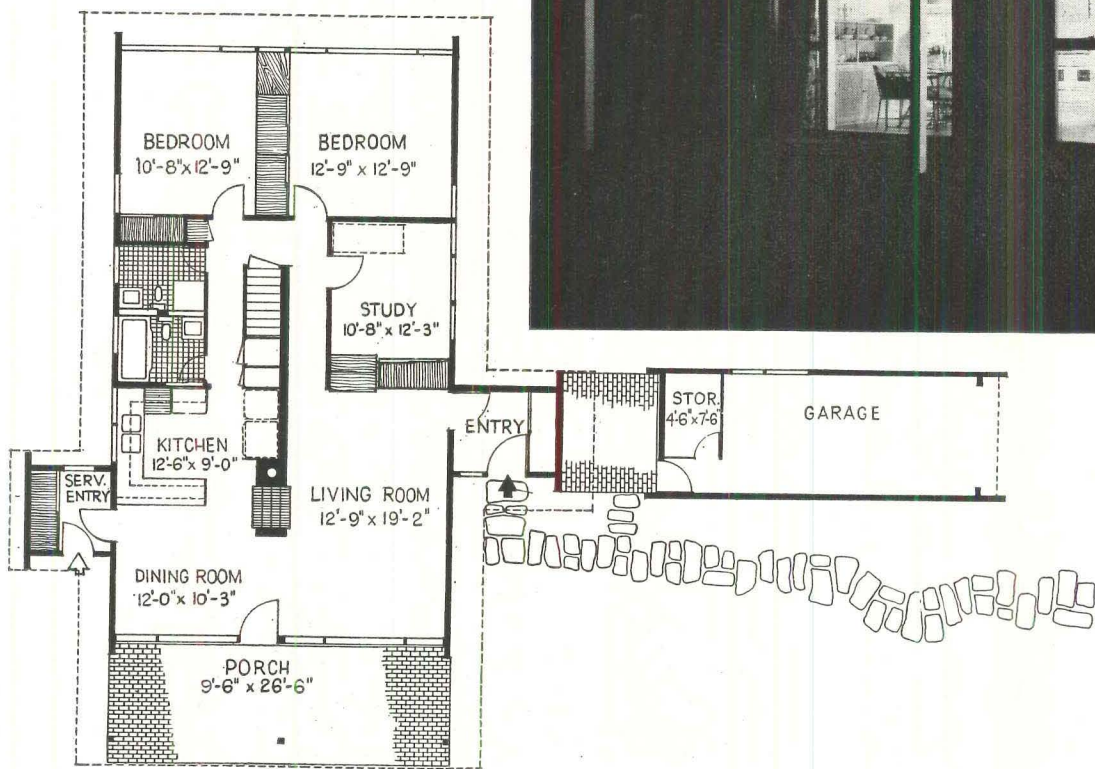
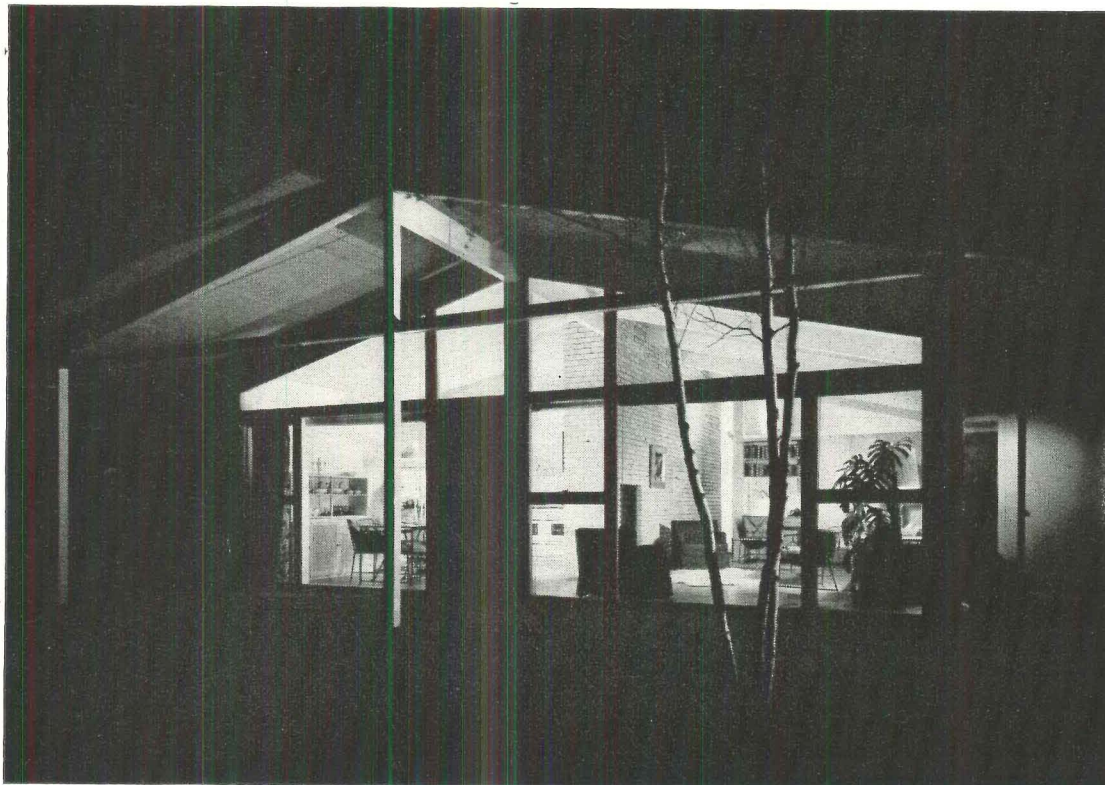

Basic plan swings living, dining and kitchen areas around a central brick bearing wall pierced by a raised two-way fireplace. Full wall of glass merges living end of house with outdoor terrace 10 ft. wide x 26 ft. long. Roof projection permits solar heating in winter, provides shade and shelter in New Jersey's hot summer.

Southern orientation, hot air grilles along sill prevent condensation and minimize heat loss through roof-high wall of 3/16 in. demi-plate glass. Glazing cost for house totals \$320.

Alternative plan puts fireplace in the almost-blank end wall, provides floor-to-ceiling windows on either side of living-dining area and extends covered entry porch 40 ft. to garage. Exterior walls are 4 in. cedar siding stained red, yellow, green, gray, blue, or brown, with end walls and trim painted white for contrast. Built-up roofs are topped with crushed limestone.

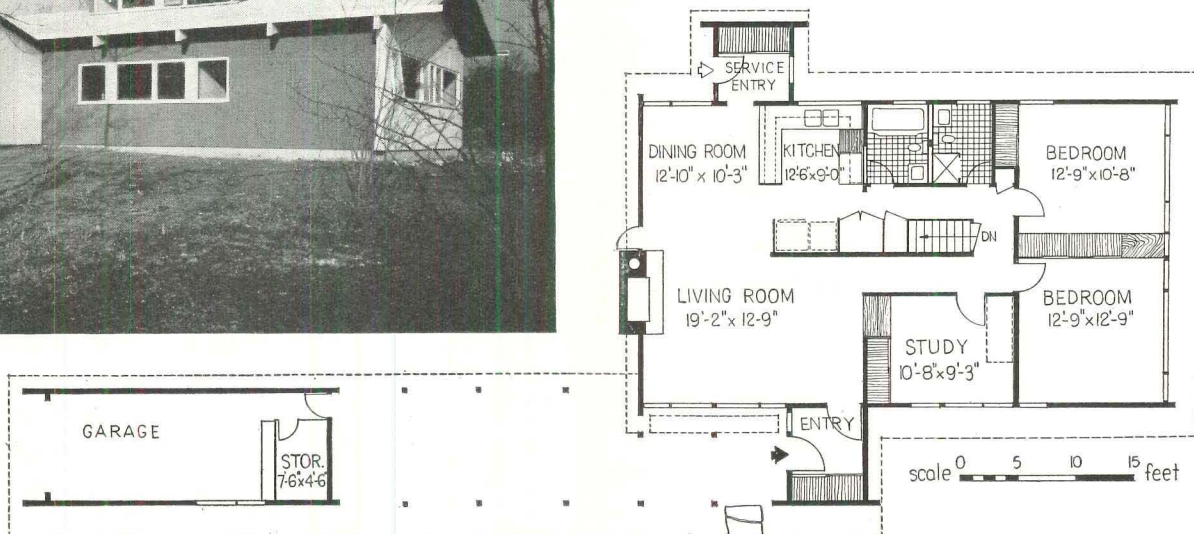
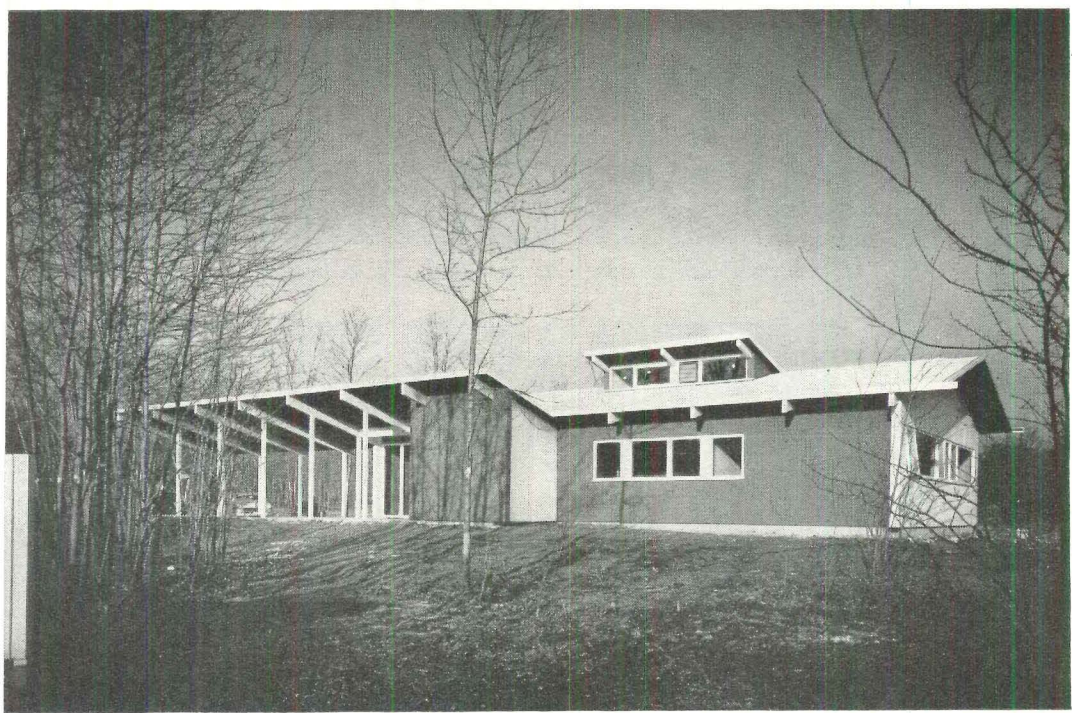



Alternate plans provide good living space, ample storage, proper siting

To take advantage of the magnificent site and meet the requirements of comfortable family living, Architects Nemeny & Geller used a type of plan and structure well-known in the West, but revolutionary for an Eastern subdivision—a ground-hugging house with a low-pitched gable roof, sloping plank-and-beam ceilings, an open plan and big window walls in the living area.

For economy and spaciousness, kitchen, dining and living areas are merged in a single big room which flows around a central core formed by storage units, kitchen equipment and cellar stairs. A clerestory lights the bedroom hall and provides natural and fan ventilation. To permit flexibility of window orientation and a variety of exterior treatment for each house, two versions of this big room and its adjacent covered porch are used. (Plans, opposite.) Otherwise, the plan of each house is economically standardized. Bedrooms are compactly grouped for privacy and ease of circulation; bathrooms placed back-to-back next to the U-shaped kitchen save plumbing costs with little sacrifice in accessibility. Projecting vestibules on either side of the house help to keep out dirt and drafts, provide generous closets and make it easier to vary orientation of the plan—either vestibule can serve as the main entry.

Ground floor storage space and built-in furniture are abundant and unusually well-planned. By concentrating a

maximum number of storage walls directly under the peak of the roof and carrying them clear up to the 12 ft. ceiling, the architects provided about 200 cu. ft. of space above conventional-height closets. Between living room and bedroom-study is a lightly-anchored storage unit that can be easily moved to another wall to merge the two areas when privacy for the smaller room is not required. Built-in equipment includes a desk and bookcase section which serves both study and living room, a dressing table in the master bedroom and a 7 ft. serving counter, a maple chopping block, broom closet, big pantry and ample storage cabinets in the kitchen. Additional storage space is provided in the garage and the 12 x 35 ft. basement.

All storage units are of natural-finish birch plywood mass-cut and assembled in a shop on the site. Their erected cost is only \$800 per house—less than the cost of an equivalent number of conventional plastered closets without the added overhead space which the wooden units provide.

In its first major appearance in the East, this type of house challenges the expansion attic models popular with many New York builders. Within the same cube, it provides more usable finished space and better storage than most attic types, and the plank-and-beam gable roof not only speeds construction but provides higher ceilings and a dramatic frame for big windows.



Compact open plan permits easy serving of meals in window-walled dining area, on roof-shaded terrace or at kitchen pass-through counter. Designed by the architects, fixture over dining table hangs from counter-weighted cord, is adjustable for height.

Photos: Pictor—Lionel Freedman



Kitchen is a handsome extension of living-dining space, with natural birch case work, light blue ceiling, white rafters and raised two-way fireplace handy for charcoal broiling. Fan draws off cooking odors, but without acoustical treatment, noise may be a problem.

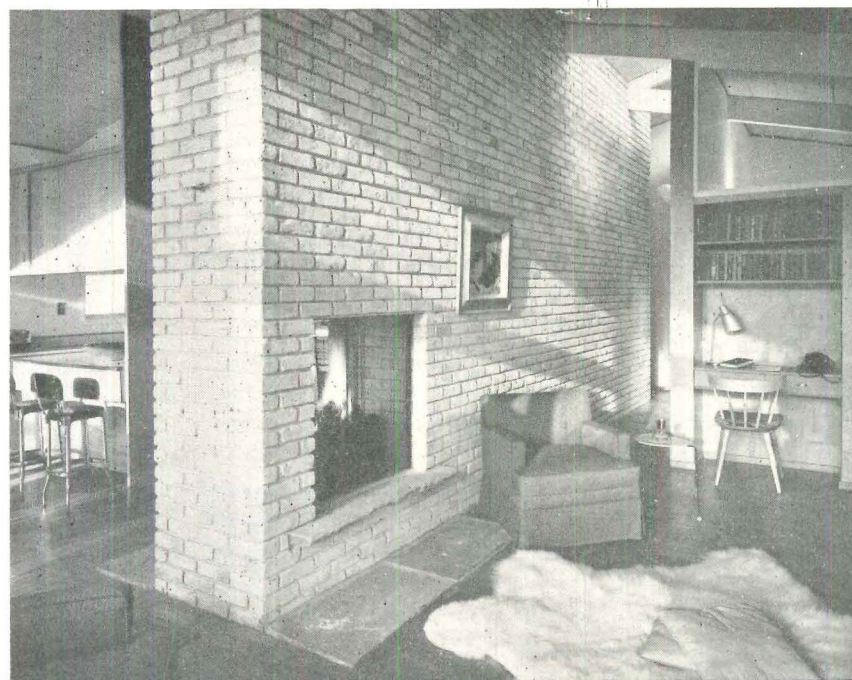

Clerestory lighting in bedroom hall and glass transom above desk-storage unit in living area add to sense of spaciousness. Brick bearing wall and fireplace cost \$700. Master bedroom (right) has dressing table built into 12 ft. high storage wall.

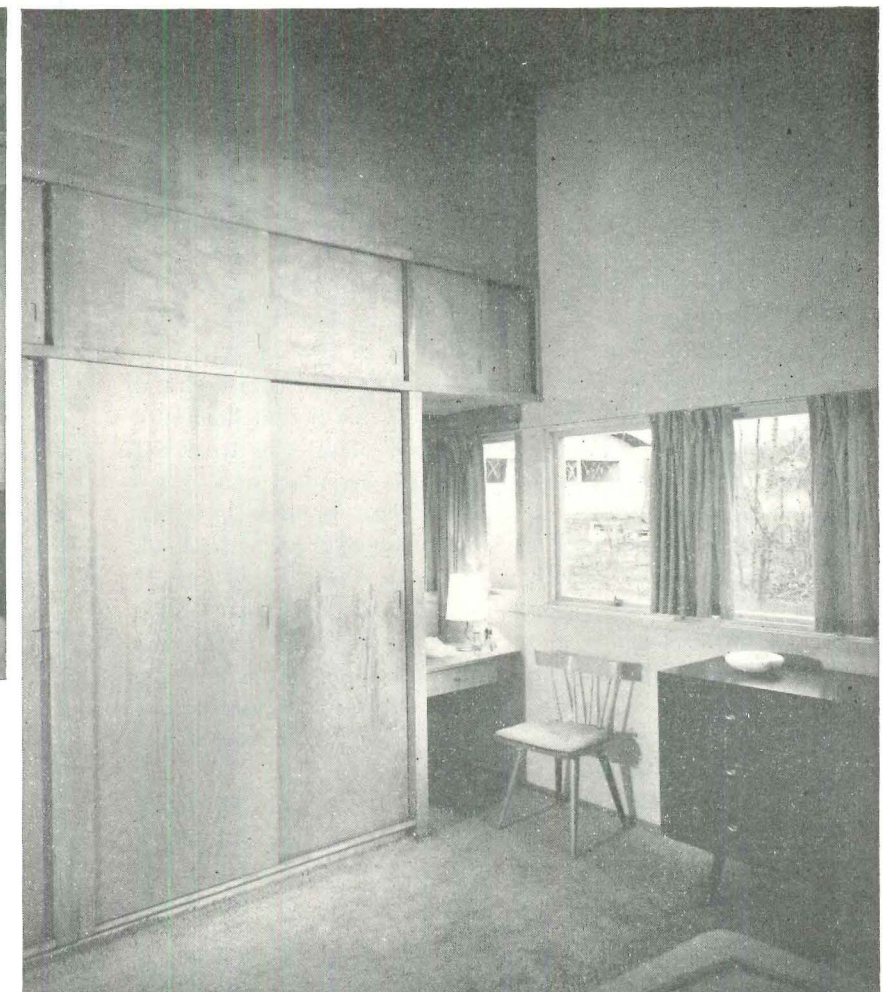

Industrial methods speed building, cut costs

The custom features shown on the opposite page were possible largely because Engineer-builder Klausner and his team of architects and engineers spent two years devising a structural system and construction methods which cut building time and minimize costly errors by workmen. Houses have a simple load-bearing skeleton of 4 x 10 in. rafters and 4 x 4 in. posts set on a 6 ft.-6 in. module and anchored into

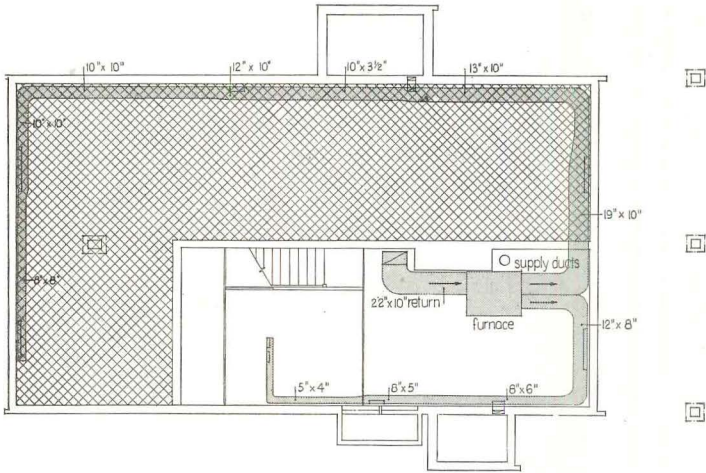

a reinforced concrete floor. Ceiling and roof are formed in one operation with 2 x 10 in. tongue and groove planks topped by insulation, waterproofing and crushed limestone. Exterior walls consist of prefabricated panels (2 x 4 in. framing and insulating board) faced outside with vertical cedar siding and inside with lightweight aggregate plaster.

The heart of Klausner's operation is the shop on the site where carpenters power-cut all framing members to exact dimensions and assemble wall panels in accurate jigs. With on-the-site framing operations reduced mainly to assembly of precision-made parts, a house can be completely closed-in under good weather conditions in a day. Klausner estimates that this system saves \$300-\$400 a house, not only by cutting construction time but by eliminating lumber wastage and carpenter errors. ("Every time a carpenter picks up a hand-saw, it costs you 20 cents.") Furthermore, sawing and fabrication under cover insures steady work, attracts good labor.

Another labor-saving feature is a floor slab of reinforced concrete supported on light steel joists above crawl space and cellar. Normally found only in higher-priced contract jobs, this fire-safe, rigid floor comes as a bonus with these houses because Klausner buys steel direct from the mill and can lay two floors a day with a crew of seven men. With lumber prices at a high level, the slab costs only about \$100 more than a conventional wood floor. As war demands for steel mount, Klausner will use heavier reinforcing rods as a substitute for I-beams, eventually may shift to wood flooring.

Engineer Peter W. Bruder's gas-fired, forced hot air system (plan, above) provides for alternate use of the crawl space beneath two-thirds of the house as plenum. If duct-work becomes unobtainable, the crawl space can be sealed off with building paper at the foundation line and 2 in. foam glass insulation applied to the walls to form a pressure chamber for heat distribution without ducts. Bruder estimates that heat loss from this space would be about the same as that from an ordinary room. Owner's heating cost with present system averages \$18 a month including hot water.

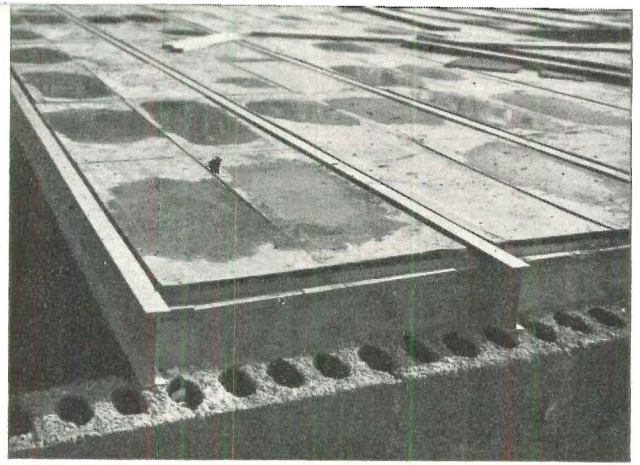

Reinforced concrete slab, 2 in. thick, is poured on steel-faced plywood forms fitted between steel joists set 2 ft. on centers.

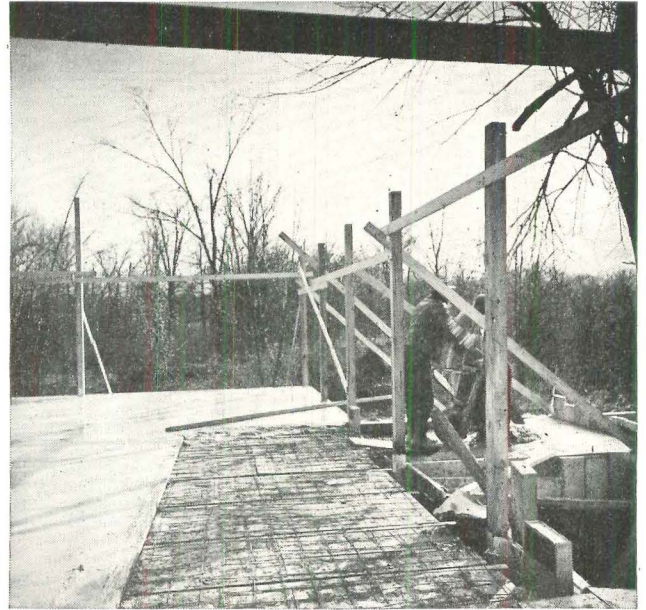

Heating outlets and pre-cut posts are set before slab is poured. Hedgehog of half-driven 30 d. spikes anchor posts to slabs.



Prefabricated wall panels, with window openings framed-in and insulation attached, are spiked to posts (above). Panels, pre-cut rafters and roof planking go up in a day (below).

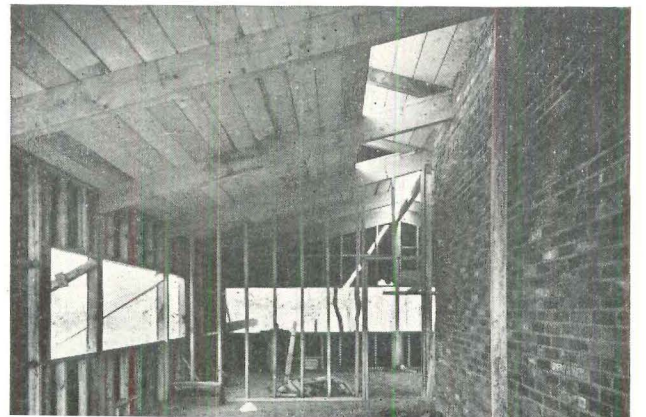



Arthur Lavine

TEXTURED MANSION

On a Mexican hillside, a colorful paradise

ANSHEN & ALLEN, Architects

At first sight this amazing house looks like a cross between a Mayan temple and the things Miss Carmen Miranda wears on her head.

Neither comparison is entirely inaccurate: The workmen who built this semi-tropical fantasy worked with ancient tools and ancient materials that belong to their land; and the result of their labors that now, after three years, stands on a mountainside near Taxco has all the glamor and color of a Latin American jungle.

To the modern builders of an industrialized nation, this house can only spell escape. Its architecture is almost surrealist and almost prehistoric; its textures are the product of handicrafts; its charm,

in great part, stems from such unaffected building as is done by men to whom blueprints mean little, and to whom speed and time mean even less.

This does not mean that the only lesson this house can teach is to throw away blueprints and to return to ancient handicrafts. Translated into modern idiom, its lessons are to let structure speak for itself clearly and repeatedly, to exploit the decorative patterns of local materials, to show more daring with color, and to restudy the many ways in which natural light—from above, or through perforated walls—can turn a simple house into a poetic Shangri-la.

Charles Kassler



Dining terrace is screened by a grille of tile. Retort-shaped concrete girders cover entire length of main wing, rhythmically articulate the unorthodox structure
Maynard Parker





Spectacular living room (above) has wine-red seating pads on rosewood platforms. Floor is clay-colored. Skylight runs along roof ridge for entire length of house. Dining terrace (left) overlooks deep pool to the west.



Photos: Charles Kassler and Maynard Parker

A way of building, a way of life

To get to their mountain site, architects Anshen and Allen had to run a four mile road out from the nearest highway. What they struck at the end of their road was a cascading stream, a cave, a cluster of wildly sprawling trees (including banana trees), and a setting that could become a part of just about the most glamorous architecture they could devise.

To tame the waterfalls, they built a series of dams, formed swimming pools at different levels. To tame the mountainside, they cut ascending terraces into the slope, paved them with flagstone and retained them against the water with heavy limestone walls. Upon these terraces the architects then built their house.

Closest to the pools and the waterfalls beyond them is the main wing, facing east. It consists of four major spaces strung out along a covered porch, and spanned by two rows of sculptured concrete girders that are cantilevered rather like a chemist's retort; the tips of these "retorts" are joined by a skylight that is continuous over the whole length of the main wing, and forms the ridge of its pitched tile roof. Most of the owner's day is spent in this wing: It has alternating indoor and outdoor living areas, a handsome kitchen with an extravagantly curved hearth, bedrooms and a study in a balcony above.

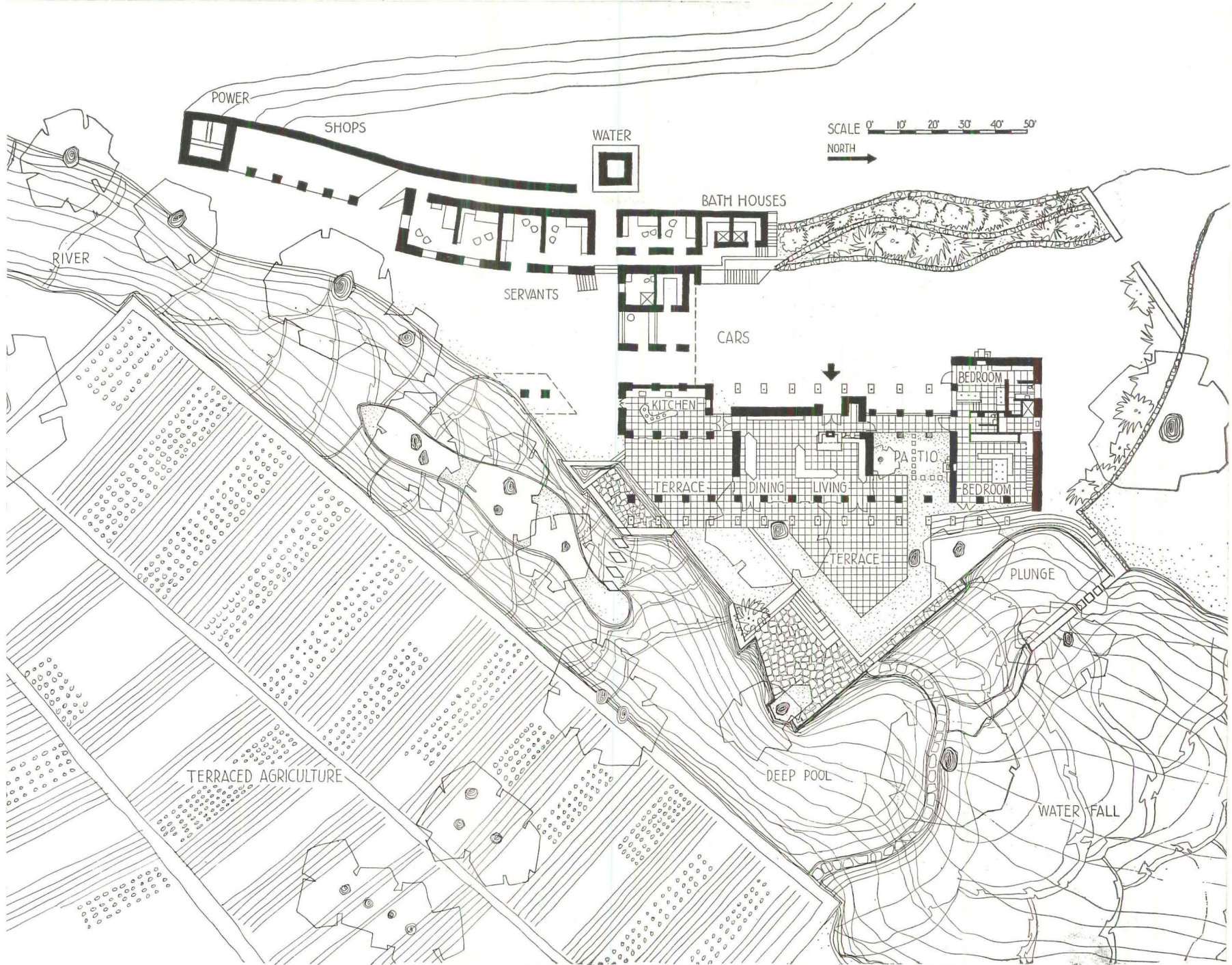

View of living room (left) looking south. All furniture, pottery and fabrics were made locally. Passage to kitchen (above) is in rear. Free-shaped concrete hearth has the brutal simplicity of a prehistoric implement.

Photos: Charles Kassler

Photos: Maynard Parker and Charles Kassler

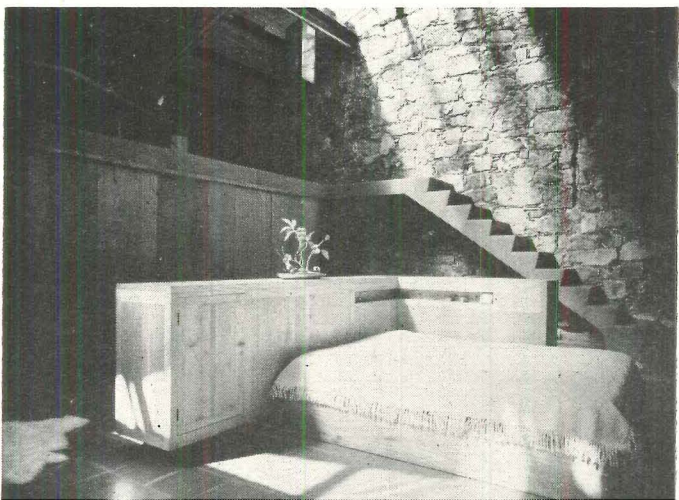
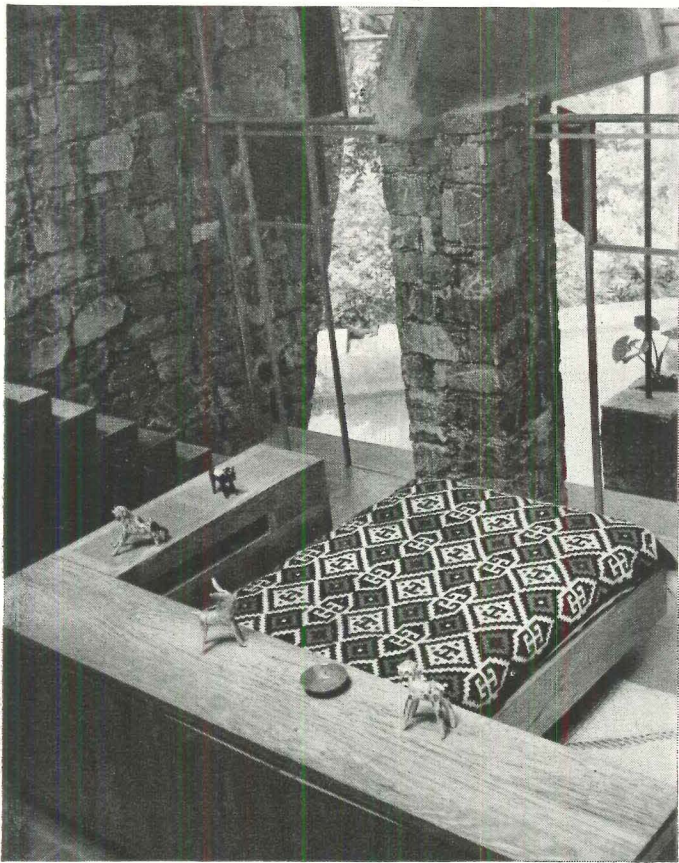

Uphill from the owner's quarters, to the west, there is the inevitable servants' wing with workshops and bath houses adjoining it. This portion of the house is handled more traditionally, without the plastic excitement of the main wing. And protecting the whole building complex is a series of rubble stone retaining walls that hold back the mountains above.

Under the direction of Don Antonio Pineda, a local bigwig, the workmen performed their three-year task with such loving care that, in the end, they hated to finish the job. The unglazed roof tiles they brought from nearby villages. The cedar of Guerrero, supposedly the best in Mexico, was right there, too. The cantilevered concrete "re-torts" were cast in place under the architects' supervision—and the

Amnon Rubinstein

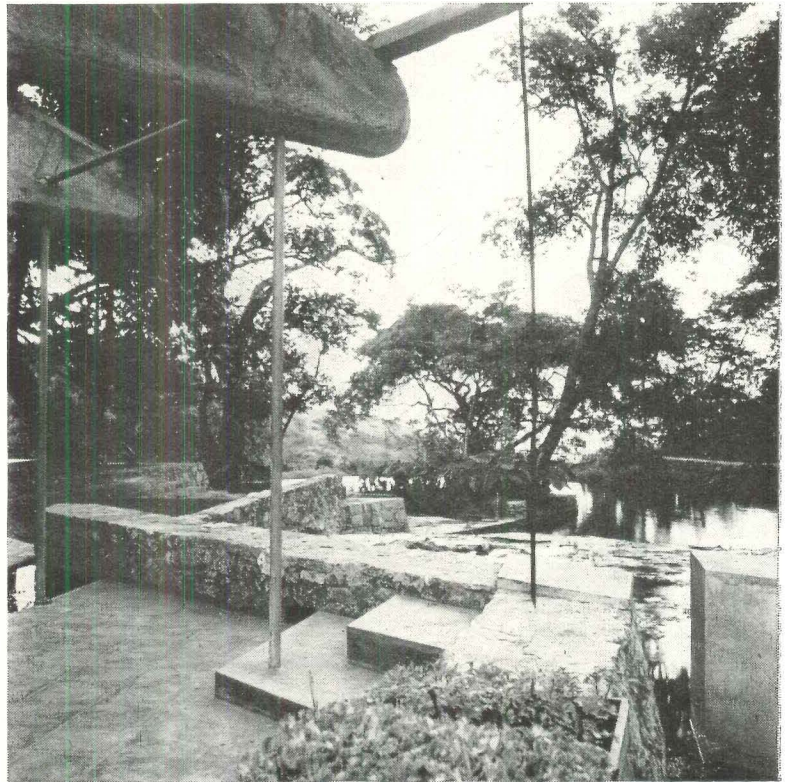

job took four long months. When it was done, the striking motif of these girders in constant repetition gave the house considerable unity. Compinseran (rosewood) bolted down to a stone base formed the furniture in the living room. Red plaster finished off the abstractly composed fireplaces. And all the fabrics were woven locally, and the pottery turned on local wheels. For the client had long been an ardent promoter of native arts and crafts in the Taxco area; and the long and devoted process of building this house seemed eminently fitting in a land that still found pleasure in manual workmanship.

To those who believe in a more austere and disciplined architecture, the explosive flamboyance of Anshen & Allen's poetry may seem a trifle extrovert. Yet, the poetry that this house unquestionably possesses is something for which people of a more sober civilization have often yearned; and the primitive means by which it was achieved here can be a challenge to us to bring back some of these qualities into our own more prosaic way of living.

(Left, top to bottom:) Semi-enclosed patio is part of main wing, adjoins bedroom to the north. Steps on side of bedroom lead up to study area in open balcony. (Opposite:) Wide steps lead from bedrooms in main wing down to specially protected swimming pool for early morning plunge.

Photo: Charles Kassler



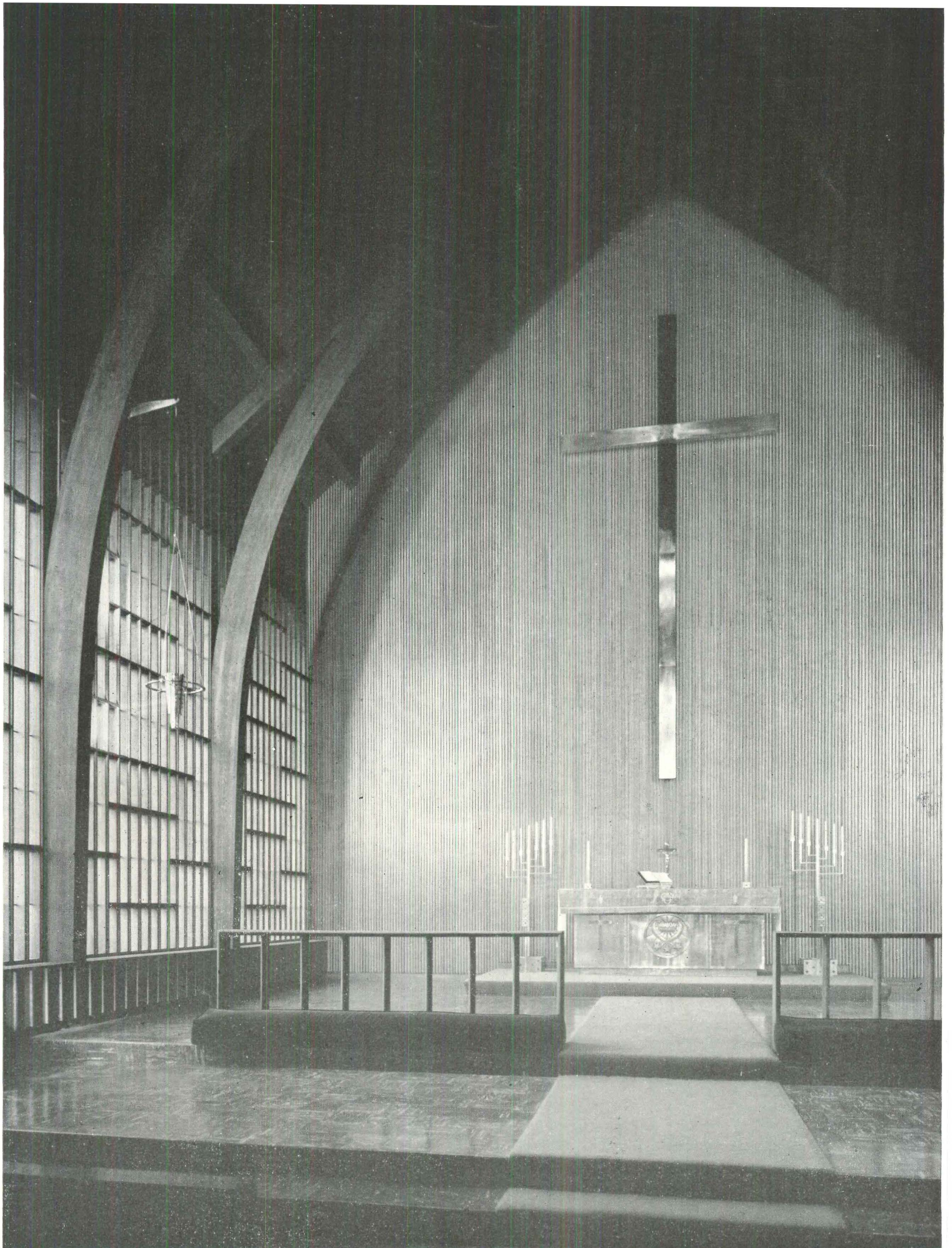

CHURCH

by Architect Belluschi shows how new techniques and materials can update an old tradition

LOCATION: Portland, Ore.
PIETRO BELLUSCHI, Architect
C. M. CORKUM CO., Contractor
FREDERIC LITTMAN, Sculptor

In Zion Lutheran Church Pietro Belluschi has taught a fine lesson in how beautifully and how very economically the new techniques and materials of our generation can be used to create a structure rich in all the warmth and vitality of the Christian tradition.

With only the simplest contemporary materials—nothing but grooved fir boards, redwood battens, rose and amber glass set in wooden studs, laminated wood arches, and glass block patterned into otherwise windowless brick curtain walls—he has contrived from his unadorned construction a place of worship so rich and colorful that hardly a penny was spent for added decoration.

Construction cost of this 300-seat church was only \$100,000, but it would be hard to overvalue the pains and the originality the architect had to pour into his work to

achieve at so low a dollar price such a creative answer to the great problem of religious architecture today—a church that will preserve a strong emotional appeal without retrogressing to the means and devices of another age.

One reason for Belluschi's success in a field where so many practitioners have failed is that instead of imitating the means by which great church builders of the past gained their effects, he has kept his mind on the basic needs from which all these sprang:

- ▶ A chancel on which all attention is focused;
- ▶ A nave, comfortable but unassuming.
- ▶ Entrances, inviting and well-placed.

The village character of Zion church is rather startling in its urban neighborhood. Its main entrance is set back from the corner and shielded from the elements by a broad eaved porch.

Photos: Roger Sturtevant



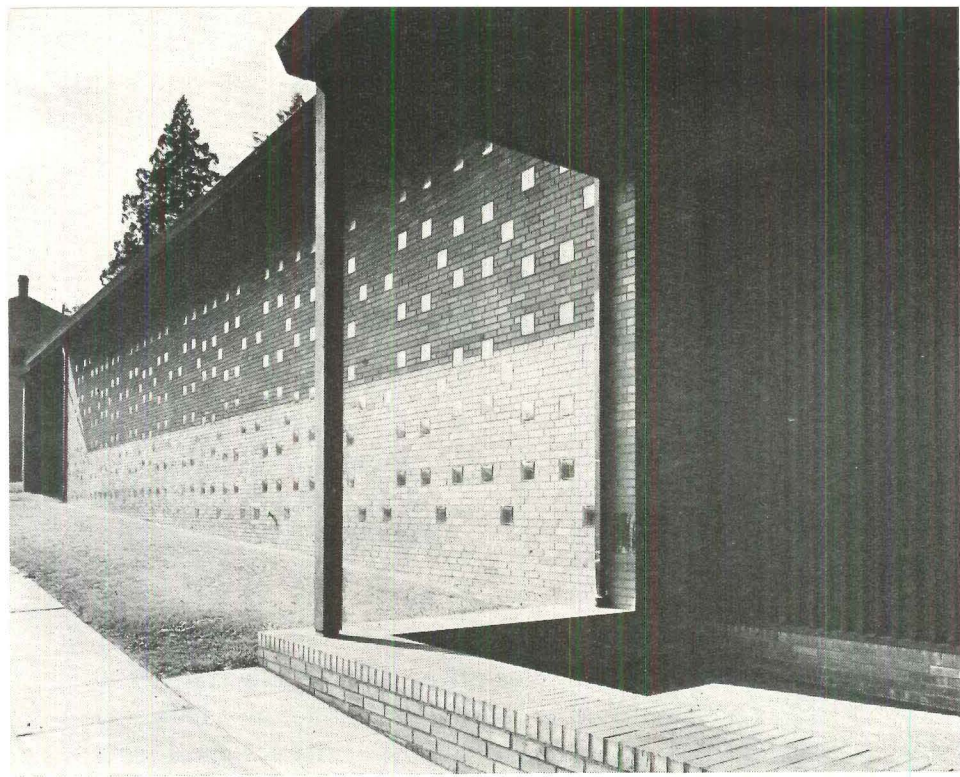

Glass block is set flush with the exterior face of the brick walls (above). The small narthex (below) provides a coat-room, has walls of birch plywood.

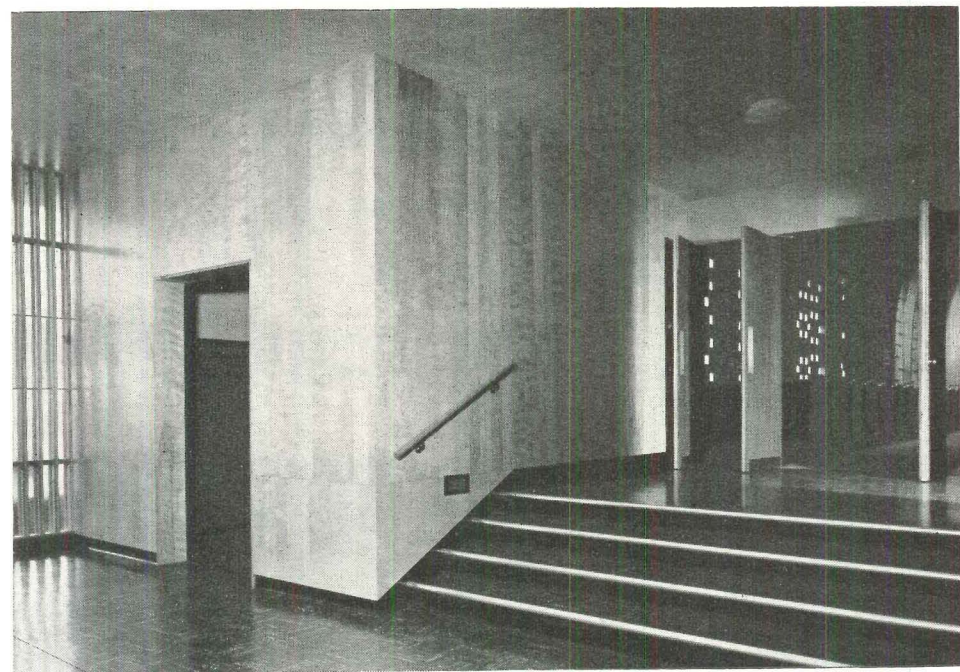

Inner cavities formed by the glass blocks (see below) are lined with copper sheeting which amplifies and warms the light, echoes the finish of the entrance door.

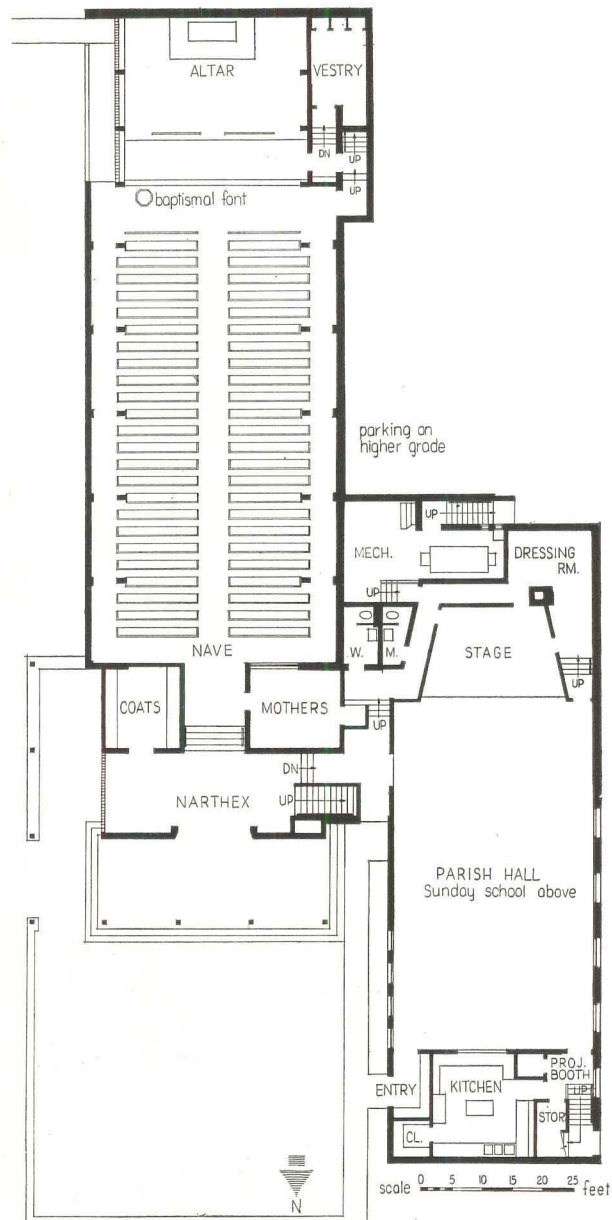
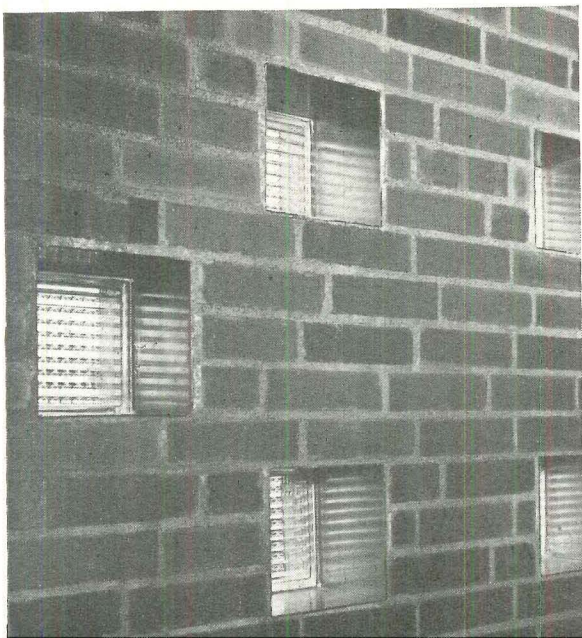

Plan of church and lower level of parish hall (above) reveals thoughtful design. Note break in the wall-line of the chancel to bring windows in closer; secondary entrance to chancel from the parking lot.

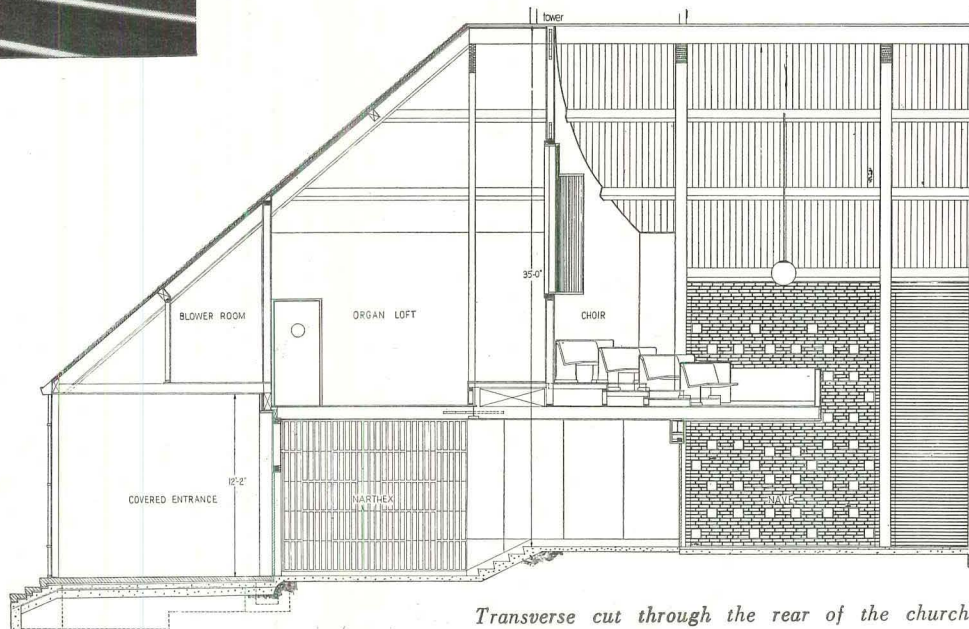

Transverse cut through the rear of the church brings out coordination of details: grooved ceiling boards; pattern of glass block and brick wall; glazed paneling in the narthex.

The windowless nave—perhaps the first windowless nave in this country—represents a unique combination of luminescence and economy. Belluschi has jewelled it with glass block with as much imagination and care as if it were imported crystal—and with as handsome effect. The spacing of 10 in. blocks was worked out to provide a soft over-all glow, bright enough for visibility, subdued enough to avoid attention on its own account. The blocks admit just enough light so that the almost hidden electric lights are not needed on clear mornings. Blocks are set flush with the outer face of the wall; the inner cavity of each is lined with gleaming copper.

Brilliant chancel

To achieve the dramatic light contrast between chancel and nave the east wall of the latter is all glass, with the window line set a good 3 ft. in from the main wall of the church. A pattern of amber and rose rectangular panes give a warm glow to the whole area. The simple metal surfaces of the large brass cross and candlesticks, of the copper baptism font and altar front, focus the sun's rays (both artistically and theologically) on the principal objects in the sanctuary. The rich brown and red of brick walls and arches are complemented by the warm green floor.

Free-standing arches

For perhaps the first time in a church the laminated arch has been used with a full sense of its power. The eight slender arches form a rigid frame structure which supports the entire roof load. (The extensive use of glass block in the walls is possible because these serve merely as screens.) This separation of the wall and column loads is dramatized by bringing the arches down free and clear of the walls along the inner lane of the side aisles. The resultant narrower span permits the arches to follow a more vertical and delicate trajectory and eliminates any triangular "haunch" above their curve. Total cost of the arches was less than \$2,500.

Delicate details

Redwood battens, used like a reredos, present a striking visual harmony with the upward swing of the arches. They also provide an acoustically absorbent surface to counterbalance the reflective masonry walls on the sides. The fir boards which surface the ceiling and back of the nave, are grooved with cuts about 1/2 in. apart to repeat this and carry further this visual motif and acoustical device.

Windowless nave has a soft, over-all glow. The chancel is lighted dramatically by a glazed screen of warm rose and amber, is accented by simple brass and copper fittings.

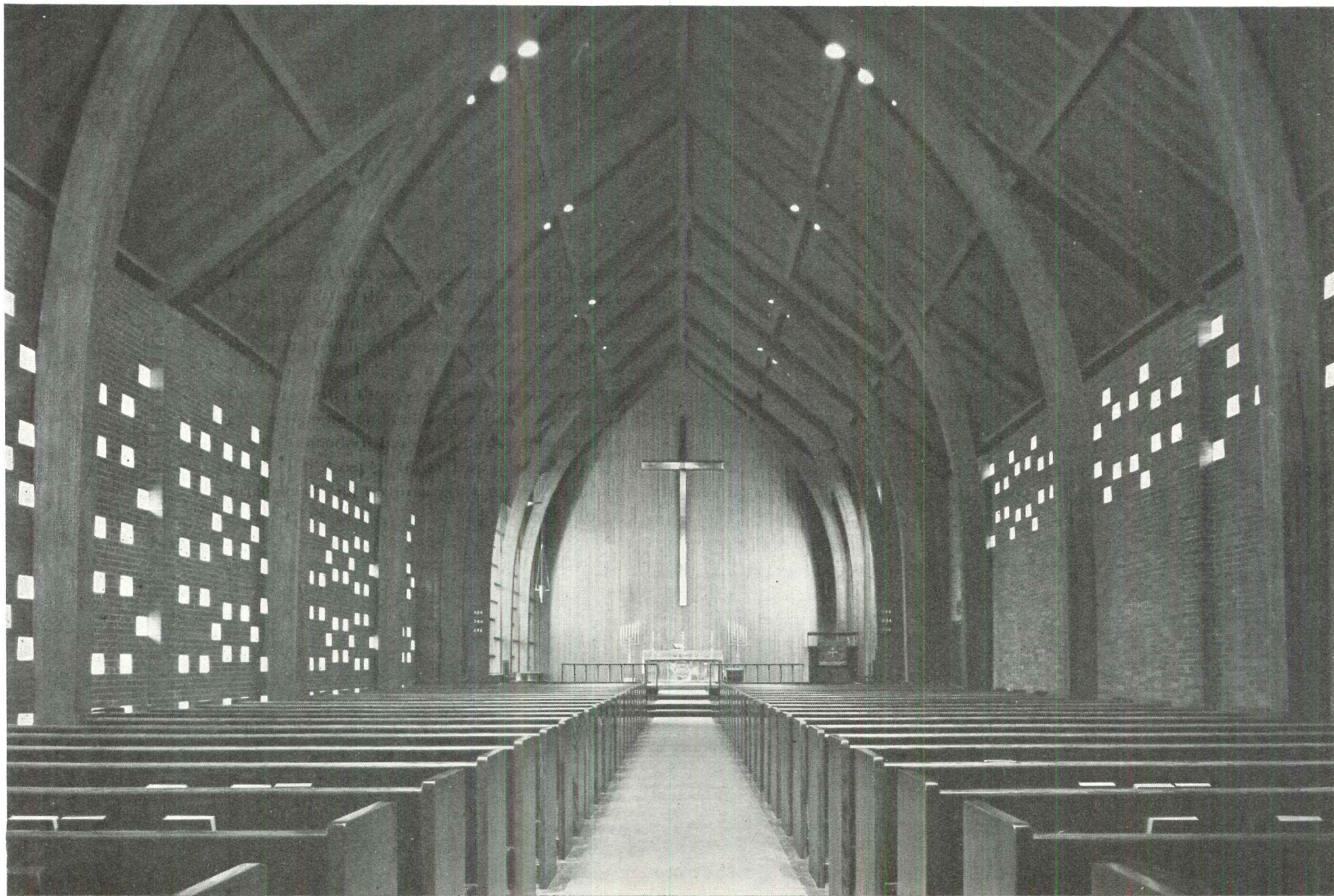



The trim spire emphasizes Zion's presence on its corner site. The entrance door—of copper sheeting decorated with a repoussé design of angels by sculptor Frederic Littman—is inviting behind the broad porch.



The church exterior preserves the same warmth and richness as the interior. Rough-sawn, brown-stained boards with batten strips complement the long walls of brick and glass block. The roof of redwood shingles broadens to a deep-eaved porch over the entrance—a satisfactory and economical protection from Oregon's mild rainy climate which makes possible a small narthex. As for the spire, Belluschi says: "There was some question about that. We were unable to argue ourselves or our clients out of it. It serves no purpose but is a symbol, and as such we believe it worth preserving . . . The very essence of organized religion is one of dogmatic and symbolic thinking."

Heating and ventilation

Simple as is the shell of this small parish church, its design would have been impossible in any age less mechanically adept than our own. The enclosed windowless nave would be unbearable without the mechanical ventilating system which operates in both nave and narthex, without the even heat provided by the radiant panels in the concrete floor slab. Forced warm air (the heating system used for the parish hall) further implements the heating of the nave. A central mechanical room holds equipment for the entire plant.

Candlesticks of brass, (right) together with the large cross and altar front focus attention on the chancel; form the church's only decoration.

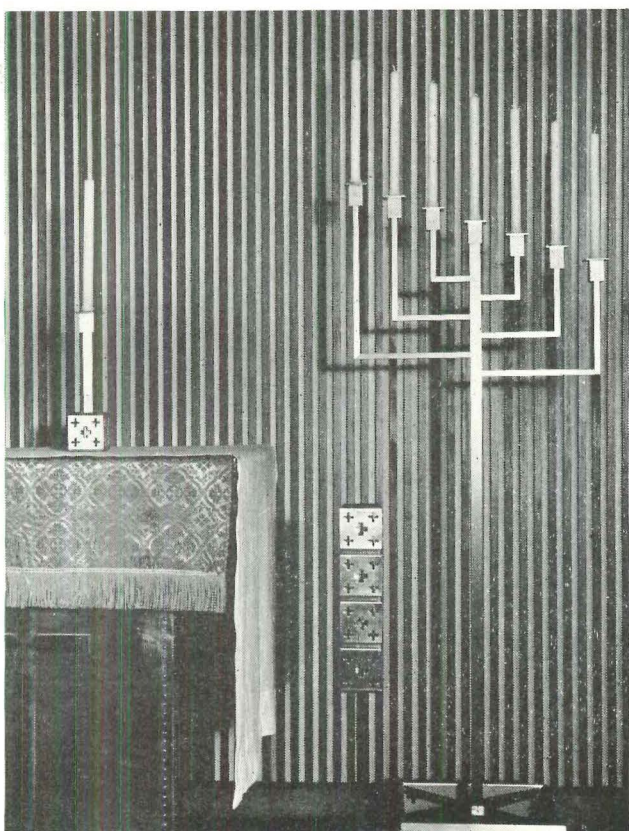



SNOW or BLOW—

it's always fair weather for

Rō-Way OVERHEAD TYPE DOORS

Let it snow, let it blow—it makes no difference in the smooth, easy operation of Ro-Way Overhead Type Doors!

Even with heavy snow drifts against them, Ro-Way Doors can't freeze shut. They glide up easily, and inside, where they're fully protected from the weather when open. They won't jam or bind, even with moisture-swollen jambs or frost-raised floors.

That's why you'll find Ro-Way Overhead Type Doors completely dependable—come snow or blow. So specify Ro-Way for *all* of your installations—residential, commercial, industrial.

ROWE MANUFACTURING COMPANY

976 Holton Street • Galesburg, Illinois

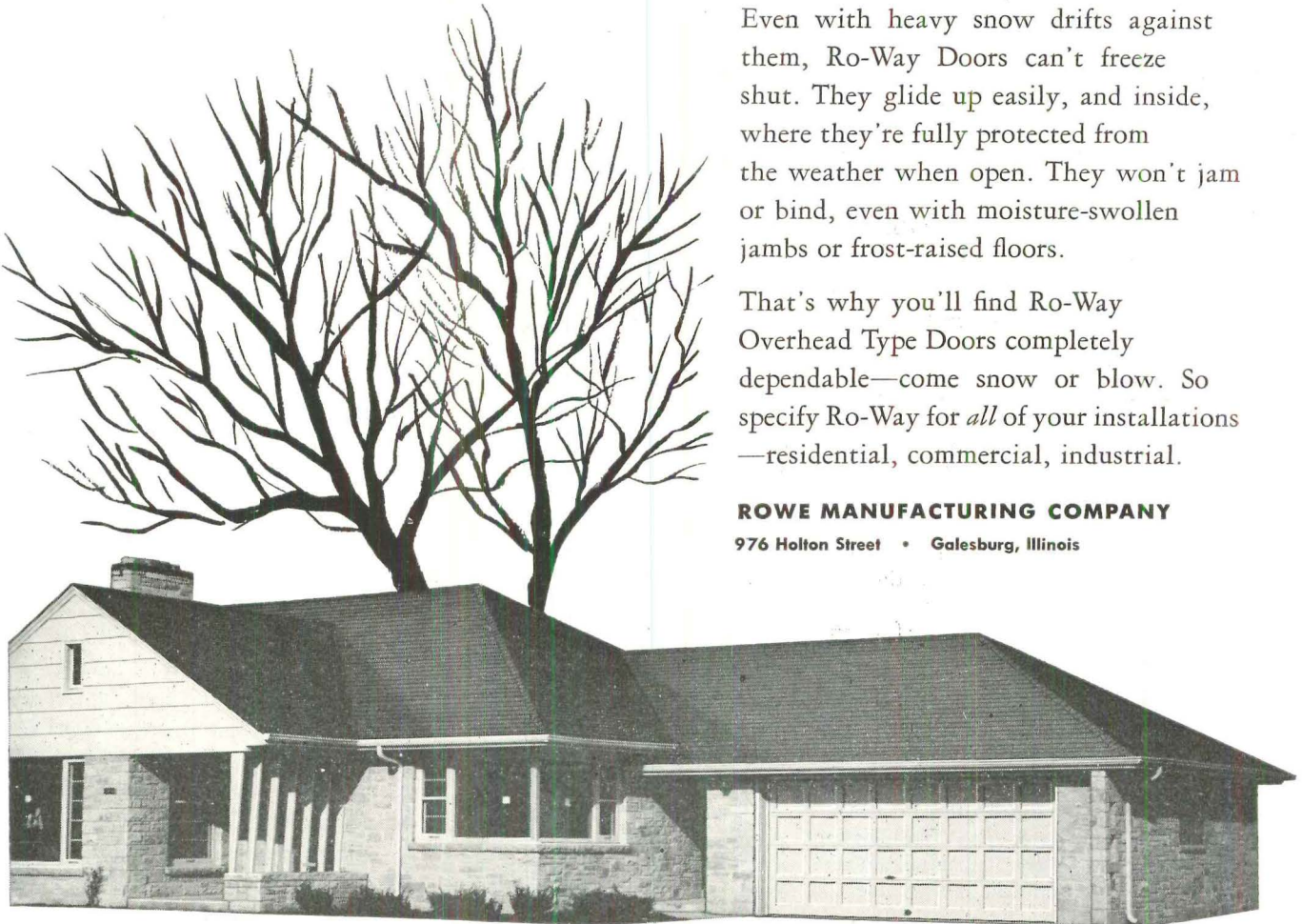

There's a RoWay for every Doorway!

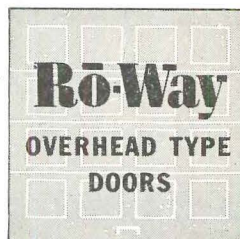

Nationwide sales and installation service. See your classified telephone directory for names and addresses of Ro-Way Distributors.



FIAT GLASS SHOWER DOORS

... dress up
the bathroom

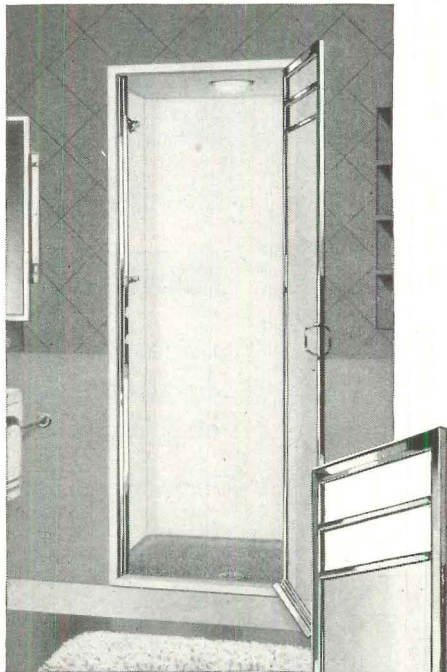

Dolphin door installed on Fiat Cadet built-in shower cabinet.

A Fiat glass door greatly improves any shower. Tile, marble, structural glass, or metal showers are enhanced in appearance and practical usability when equipped with a Fiat door. Perhaps at no other place in a house can so little cost mean so much in desirability.

☞ The solid extruded metal used in all Fiat doors is a much superior type of construction that permits a fine elite styled frame combined with strength.

☞ The Fiat Dolphin shower door is constructed of extruded solid brass, heavily chromium plated with continuous piano hinge forming a smooth-working, rigid door. Double friction bullet catches, offset handles and water channel to prevent dripping on floor are features that mark the Dolphin as the finest in shower bath doors.

☞ The Zephyr is a medium priced door, styled same as the Dolphin but made of extruded aluminum with satin aluminum finish.

Standard size of both the Dolphin and Zephyr shower doors is 72" high for opening 24" wide.

☞ The Neptune is the lowest priced Fiat glass door. Made of one piece heavy extruded aluminum with satin finish. Size 24" x 64" and is reversible for left or right hinging.

☞ All Fiat doors are simple and easy to install on Fiat shower cabinets, tile, marble or structural glass showers.

Fiat shower doors have neat, modern styling combined with maximum strength.



FIAT METAL MANUFACTURING COMPANY

Three Manufacturing Plants

9301 W. Belmont Ave., Franklin Park, Ill.

Long Island City 1, N. Y.

Los Angeles 33, Calif.

In Canada—Fiat showers are made by the Porcelain and Metal Products, Ltd., Orillia, Ontario

WANTED: Substitute materials

The common criticism of electric heat is that it is expensive unless electric rates are low. Rubber radiant panels are reported to have operating costs higher than warm air unless electric rates are around one cent per KW, although some installations have been made where rates are higher than that. There is not much rubber in these panels and the manufacturer believes this product will not be considered a critical item. This appears to be an article that can serve as an alternative for conventional heating systems in low-rate areas.

Another form of heating that uses almost no metal is radiant glass panels. Standard panel size is 21 x 30 in. and two panels for the average room are sufficient, usually installed beneath windows. The installed cost is less than any conventional system. Even though monthly electrical bills might be higher than for gas or oil heat, makers of glass panels say they can demonstrate that their system has many advantages: far cheaper original price, no annual cleaning or maintenance bills, less depreciation charges, considerable space savings, and a cleaner type of heat. A New York firm which is the largest maker of radiant glass panels believes it will not be held up by material shortages. Its products are approved by FHA and the Underwriters Laboratory. Glass heat, as with other electric radiant heat, is economically feasible only if houses are well insulated.

Electric wiring

When a builder begins itemizing all the places he uses copper he is apt to shake his head over ways to reduce electric wiring. For years Americans have been taught not to be satisfied with less than "adequate wiring"—with lots of convenience outlets and switches, to say nothing of ample lines for electric stoves, freezers, appliances, attic fans. But that takes an average of over 26 lbs. of copper wire and 177 lbs. of steel. What happened during the last war could happen again: restriction on the number of outlets and permission for only the simplest kind of electric systems. A partial answer to the copper problem is in a low voltage wiring system. By using a special, small-sized wire this system is reported to save a total of 42 per cent of the copper that is ordinarily installed in the Adequate Wiring Bureau's 1949 "Average Certified House." It would also save 86 per cent of the steel used in conventional wall switches in the average home. If local codes require steel-armored cable for conventional 115-volt systems, there can be substantial savings in steel, because the new system uses wire that is designed for 24 volts

(Continued on page 152)



GOLD BOND Again!

**THE NEW METROPOLITAN LIFE INSURANCE
BUILDING, MADISON AVE. AND 24TH ST.,
NEW YORK CITY**

Architect: (Third unit)

Arthur O. Angilly, New York City

General Contractor:

Starrett Bros. & Eken, Inc., New York City

Plastering Contractor:

James Kane & Company, New York City

**550 tons of Gold Bond Plaster
were used in this building.**

GOLD BOND Products are designed to work together, and when they are used together, responsibility for results is centered in one reputable manufacturer—National Gypsum Company. The more than 150 Gold Bond products are fully described in Sweet's.

● *Lath, Plaster, Lime, Sheathing, Wall Paint, Rock Wool Insulation, Metal Lath, Sound Control Products, Fireproof Wallboards and Decorative Insulation Boards.*

**You'll build or
remodel better with
Gold Bond**

NATIONAL GYPSUM COMPANY • BUFFALO 2, NEW YORK



Architect Norman Johnson specified this WINDOWWALL of Andersen Casement Units and Picture Windows

ANDERSEN
*Windowalls**
COMPLETE WOOD WINDOW UNITS



TRULY A WINTER WONDERLAND!—when an Andersen WINDOWALL captures a picture of sub-zero beauty, keeps the cold *outside*, yet admits a flood of winter sunshine that both brightens and warms.

Such beauty was assured when the architect opened the entire 28-foot wall of this livingroom with Andersen Casement and Picture Window Units. Comfort was assured, too ... for this is a WINDOWALL. Both window and wall, its

precise manufacture from beautiful, *insulating* wood enables it to handle extremes of weather with ease.

See Detail Catalog in Sweet's Architectural and Builders' Files, or write us for further information. The complete WINDOWALLS Tracing Detail File will be sent on request to architects and designers at no charge. Andersen WINDOWALLS are sold by lumber and millwork dealers.

*TRADEMARK OF ANDERSEN CORPORATION

Andersen Corporation

BAYPORT • MINNESOTA

House with Removable walls has MAINTENANCE-FREE SCREENING!

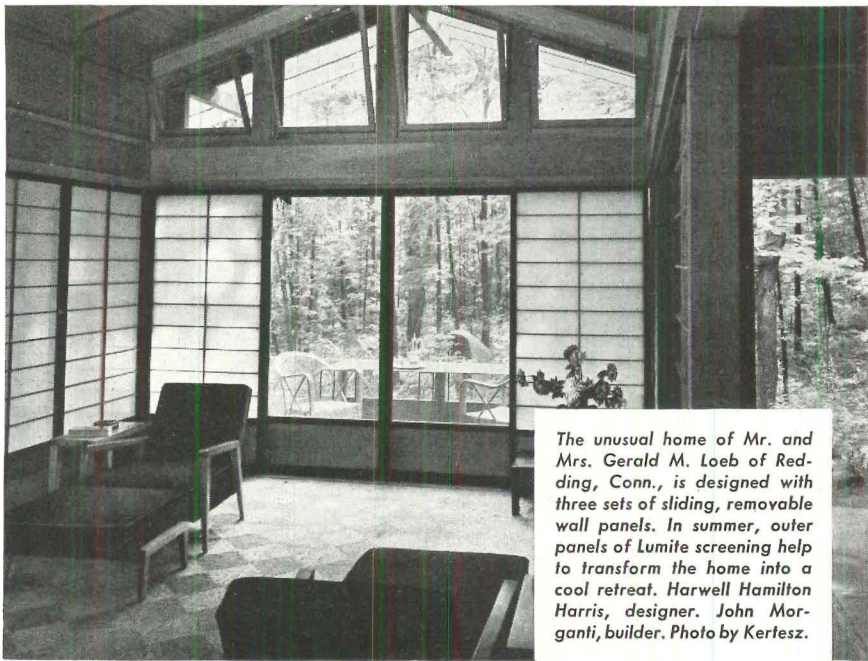

The unusual home of Mr. and Mrs. Gerald M. Loeb of Redding, Conn., is designed with three sets of sliding, removable wall panels. In summer, outer panels of Lumite screening help to transform the home into a cool retreat. Harwell Hamilton Harris, designer. John Morganti, builder. Photo by Kertesz.

It's Rustproof Lumite Saran Screening THE IDEAL SCREEN CLOTH FOR EVERY EXTERIOR USE!

★ **STAINPROOF!** Lumite Screening can't cause unsightly, costly stains on the house.

★ **LONG-LASTING!** An independently conducted accelerated weathering test proves Lumite Screening superior to all other types of screen-

ing. Replacement and repairs are minimized with Lumite Screening!

★ **NEVER NEEDS PROTECTIVE PAINTING!** Lumite Screening can't rust, rot or mildew. And—it's non-inflammable . . . easy to handle . . . low in cost.

Sold through hardware, lumber, building supply dealers and screen manufacturers.

*Registered Trade-mark



SEND FOR FREE
SAMPLE AND ADDITIONAL
INFORMATION TODAY!

LUMITE DIVISION, Chicopee Mfg. Corp. of Ga. MB-1
40 Worth Street, New York 13, New York
GENTLEMEN: I am interested in the rustproof, stainproof, long-lasting qualities of LUMITE Saran Screen Cloth. Please send me FREE sample and further information.
NAME.....
COMPANY.....
ADDRESS.....
CITY.....ZONE.....STATE.....

WANTED: Substitute materials

rather than 115 and has a thermoplastic insulation that requires no additional protection.

When the "remote-control" feature of this system is used parts or all of the lighting can be turned on or off from one or more central points. Secret is a small relay with split-coil, dual-action solenoid for off-on switching controlled by a minute flow of an independent electric current at low voltage through small flexible wires. The manufacturer is so confident of the advantages of this system that it predicts in 10 years all new houses will be using it.

Where local codes permit, BX cable can be eliminated and non-metallic tubing and conduits used instead, or non-metallic sheathed wires or cables. Wire can be saved by eliminating 3-way and 4-way switches, by cutting out signalling systems including door bells, substituting porcelain or other non-metal materials for outlet boxes and by installing as few metal fixtures as possible.

Plumbing

Plumbing supplies, as every builder knows, are likely to be among the most critical items. When Washington officials begin blue penciling construction uses of copper, brass and steel they are sure to eliminate part of the average plumbing system. Small builders have seldom been able to design plumbing layouts so there is as little waste as in the Levitt houses, for example, where not a foot of pipe is used unnecessarily. But most are aware that if they are forced to they could install an austerity system that used less pipe. When it becomes necessary, one bathroom can always be built instead of two.

When copper and brass pipe becomes impossible to get builders can go to steel, and when that becomes too short they can go to galvanized iron. For plumbing fixtures such as bath tubs, sinks and washbasins they will have to depend on the manufacturers and take what they can get. Kitchen counters and sinks can be made of tile. Tile can be of great help to a builder for dressing up the bath and kitchen.

Metal for gutters and leaders can be saved by wood replacements. Some builders use wide overhangs and eliminate gutters.

How about plastics?

The question of plastics as substitutes has echoed through the construction industry. Plastics have been accepted for so many items that builders forget they are made of plastic. If FHA and the Fire Underwriters approved a plastic item, builders often accepted it on face value.

(Continued on page 156)

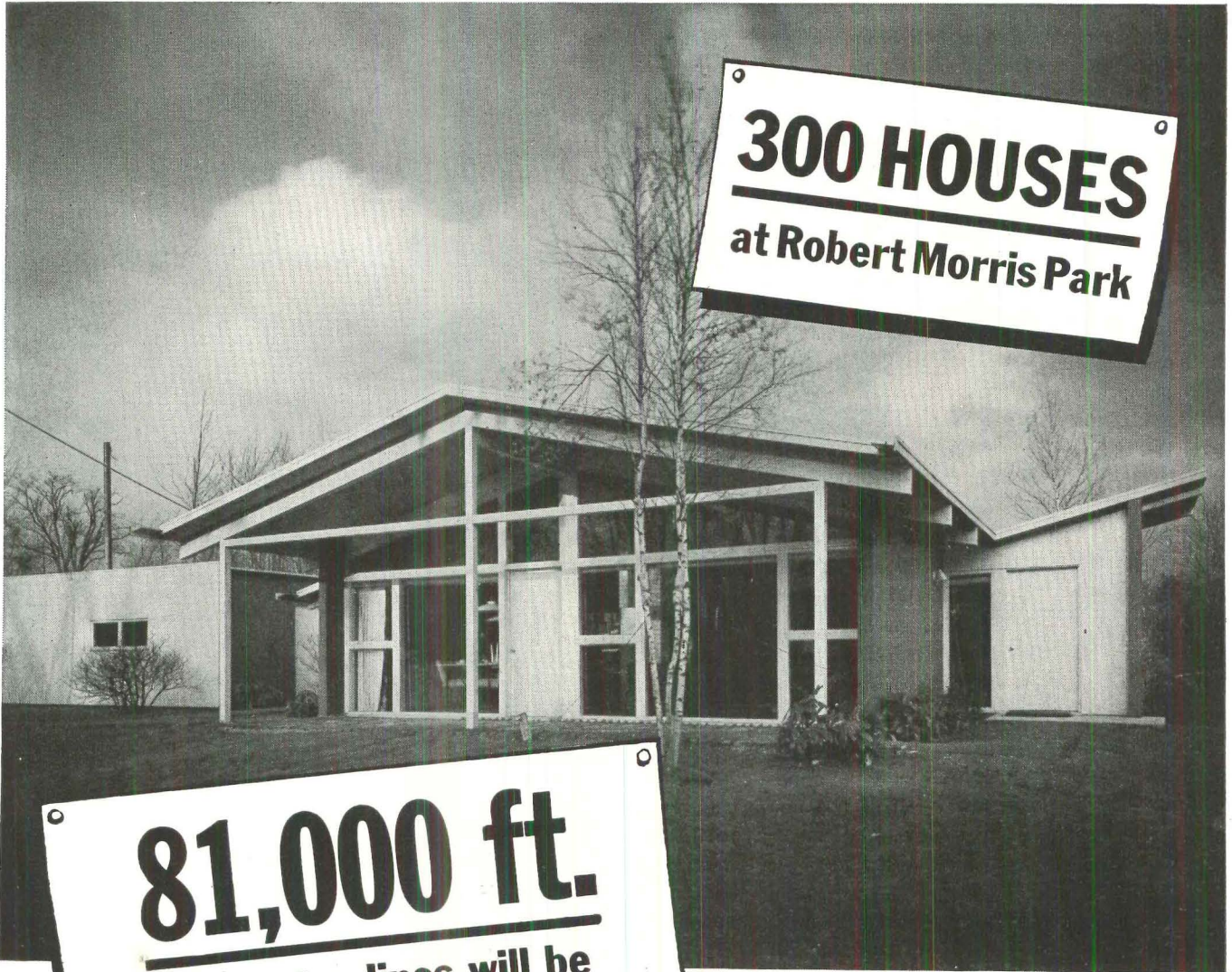

300 HOUSES
at Robert Morris Park

81,000 ft.
of water lines will be
of enduring, non-rusting
REVERE COPPER

One of the 300 homes being erected at Robert Morris Park, Morristown, N. J. by Standard Holding Co., Builders, New York, N. Y. Architects are George Nemeny, New York, N. Y. and A. W. Geller, New York, N. Y. Plumbing Contractor, A. O. Timmins, Sparta, N. J.

A GAIN, it's "Copper where it Counts". In these 300 homes at Robert Morris Park there will be 33,000 feet of 3/4" Revere Copper Pipe, used for service and hot water lines, and 48,000 feet of 1/2" Revere Copper Water Tube for cold water lines. In addition, all chimneys will be flashed with Revere Copper.

Whether it be in residential or skyscraper building, more and more architects, builders, engineers and contractors are pinning their faith on Revere Copper Water Tube, Revere Copper Pipe, and Revere Copper for flashing gutters and downspouts. For copper endures through the years, is non-rusting, and thus costs less in the long run.

In addition to its other advantages, Revere Copper Water Tube also provides many economies during installation. This tube is stamped at regular intervals with the Revere name and type, so that you can immediately identify it as a top-quality tube of full wall thickness and

close dimensional tolerances. It is ideal for radiant panel heating.

Other Revere building materials include Revere-Keystone Interlocking Thru-Wall Flashing,* Revere-Simplex Reglet Flashing,* and Red Brass Pipe. All are available through leading distributors in all parts of the country. For Revere Technical Advisory Service call the distributor nearest you. *Patented

SEE OUR CATALOG IN SWEET'S

REVERE *150th YEAR OF SERVICE TO AMERICA*
COPPER AND BRASS INCORPORATED

Founded by Paul Revere in 1801
230 Park Avenue, New York 17, N. Y.

Mills: Baltimore, Md.; Chicago and Clinton, Ill.; Detroit, Mich.; Los Angeles and Riverside, Calif.; New Bedford, Mass.; Rome, N. Y. — Sales Offices in Principal Cities, Distributors Everywhere

SEE "MEET THE PRESS" ON NBC TELEVISION EVERY SUNDAY

An example of the use of
THE Wakefield CEILING

integrating Over-ALL glare-free light with acoustical control

Executive Office
C. F. DENZER CO.
Sandusky, Ohio

Installed by
FRANK TRAUT
ELECTRIC COMPANY
Sandusky, Ohio



A study of this recent installation shows the very definite advantages of the Wakefield Luminous-Acoustical Ceiling for offices, drafting rooms, classrooms and other areas devoted to critical visual tasks.

1. Evenly distributed, glare-free light with exceptionally low brightness contrasts.
2. Architecturally discreet concealment of pipes and ducts with ready accessibility to them.
3. Efficient sound control integrated with the light source (acoustical baffles suspended below luminous ceiling).
4. A complete package, shipped direct to the job, and installed completely by an electrical contractor.

An Illumination Survey by a registered professional electrical engineer shows brightness ratios well below those of I.E.S. Recommended Practice of Office Lighting. For example: from 1.4 to 1 to 1.1 to 1 between task and wall; 2.2 to 1 maximum between luminous ceiling and wall.

For a copy of this survey, and for complete information on all phases of the Wakefield Ceiling, write to The F. W. Wakefield Brass Company, Vermilion, Ohio.

HOW DISTRIBUTED

The Wakefield Ceiling will be distributed through licensed agents and installed by factory-trained licensed installers. Planning will be done through electrical engineers and architects. Drawings submitted to Wakefield will be interpreted by job engineers into drawings, bills of material and quotations.

BRIEF DESCRIPTION OF THE WAKEFIELD CEILING

Fluorescent sources are suspended from structural members above. Diffusion is provided by translucent corrugated acrylic plastic sheets. Suspended below these sheets, at 36" intervals, are perforated acoustical baffles, wedge-shaped in cross section and filled with sound absorbing material.

A simple baffle rail or fusion strip and hanger constitute "the method" of installation, which involves the fewest possible supports and brings economy of structural and electrical material as well as of labor. Acoustical baffles are optional.

THE F. W. WAKEFIELD BRASS COMPANY, VERMILION, OHIO



How important is traffic flow

in modern washroom planning?

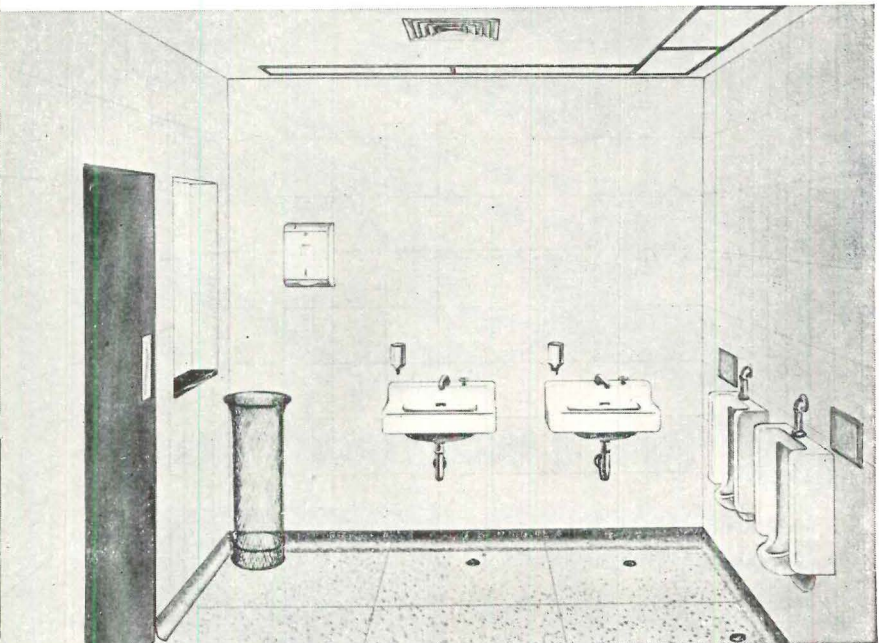
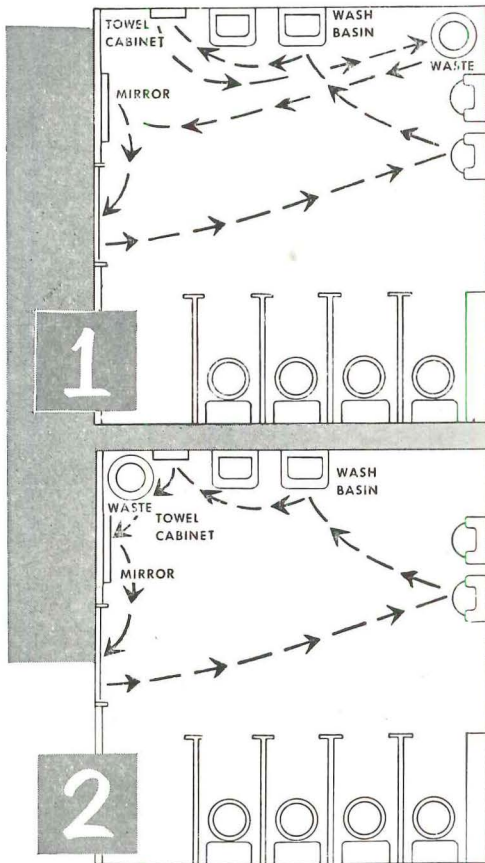

(1) One misplaced piece of washroom equipment, like a waste receptacle on the wrong side of the wash basins, will waste many man-hours a year in washroom traffic jams . . . and use up excess paper towels.

(2) A simple rearrangement lets washroom traffic flow in and out easily, quickly. Recessed vents and lighting, and off-the-floor fixtures, make this small washroom modern in every way.

Traffic flow is one of several factors that distinguish a truly modern washroom from one merely equipped with up-to-date fixtures.

This small washroom is modern in both design and function. Its users move progressively from urinals to wash basin, paper towel cabinet, waste receptacle and mirror, then out the door. The plan eliminates congestion—actually reduces man-hours spent in the washroom. It reduces your client's

paper towel costs, too. The staggered towel cabinet and waste receptacle arrangement keeps users moving, gives them little chance to use more towels than actually needed.

At no cost or obligation, you can call in the Scott Washroom Advisory Service to make use of the know-how of trained consultants who have serviced well over 300,000 washrooms. Your Scott Washroom Advisory Service man is equipped to give you

the latest answers on all-around modern washrooms as an integral part of new and old buildings. You'll save your clients countless employee man-hours, help them build good personnel relations by installing the newest sanitary improvements.

Contact Washroom Advisory Service, Scott Paper Company, Chester, Pa.



Send for **FREE Leaflet . . .**
"Plant Washroom Designing"

Washroom Advisory Service, Dept. V
Scott Paper Company
Chester, Pennsylvania

At no cost or obligation, please send me your study of personnel, traffic and maintenance problems, "Plant Washroom Designing."

Name _____

Company _____ Title _____

Address _____

City _____ Zone _____ State _____



SCOTT
Symbol of
Modern Washrooms

Trade Marks "ScotTissue," "Washroom Advisory Service" Reg. U. S. Pat. Off.

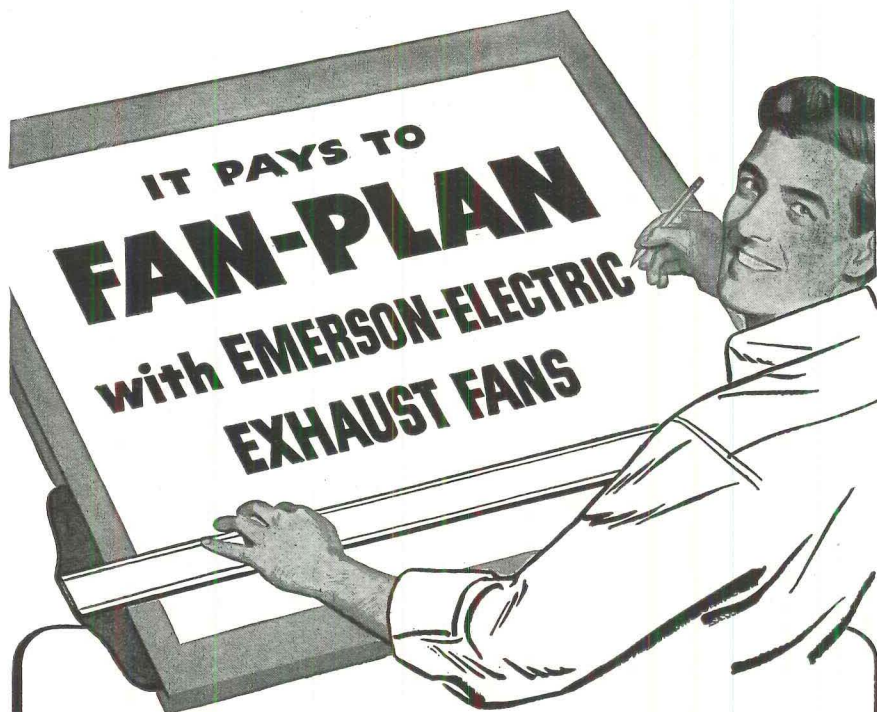

NEW! POPULAR-PRICED EXHAUST FAN LINE

... complete with automatic shutters!

Here's a brand-new direct-drive exhaust fan line . . . built for easy installation and rugged service! Available in 12-, 16-, and 18-inch blade sizes, with capacities of 1350, 2050 and 3100 CFM, equipped with special fan-duty sleeve-bearing motors and automatic outside shutters mounted integral with fan! Write for prices and specifications today!

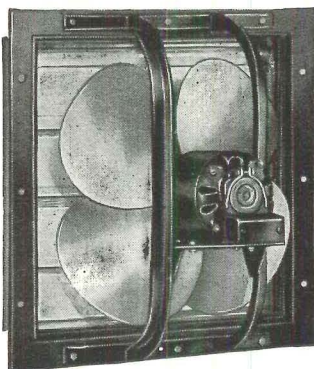

You give your clients *three* distinct advantages when you specify Emerson-Electric ventilating equipment for commercial and industrial projects. First, you assure the right fan for every air-moving job, from America's most complete fan line. Emerson-Electric's famous guaranteed *quality* assures unmatched dependability and service. And finally, you make available Emerson-Electric's free *fan-planning service*, bringing 60 years of fan experience to your individual problems. For complete data, write for Bulletin No. 415.

THE EMERSON ELECTRIC MFG. CO., St. Louis 21, Mo.

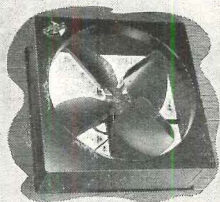

◀ **BELT-DRIVE EXHAUST FANS** — long-life, slow-speed ball-bearing models in 24-, 30-, 36-, 42-, and 48-inch sizes, exhausting up to 19,350 CFM.

▶ **DIRECT-DRIVE EXHAUST FANS** — five top-quality models; blade sizes 12 to 30 inches. Fully-enclosed ball-bearing motors; quiet overlapping blade assemblies.

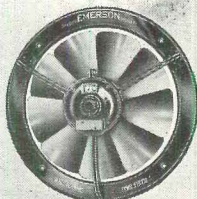

EMERSON
MOTORS • FANS



ELECTRIC
APPLIANCES

WANTED: Substitute materials

Take plastic pipe as an example. Several firms make plastic pipe up to 6 in. in diameter. Most of it goes for industrial purposes where flexible or semi-rigid pipe is needed for handling corrosive materials, in mines, oil wells, on farms for carrying cold water or other liquids, petroleum products or other special purposes. Some types can be laid underground without deteriorating or freezing. Some plastic pipe could be used for cold water lines in houses or commercial buildings.

Plastic pipe is being used too many ways in industry to be considered experimental. But it must be used as manufacturers specify. Some will take hot water and some won't. Rodents enjoy the taste of one type, but turn up their noses at others. The use of asphalt fiber pipes that are already giving satisfactory service for waste lines outside the house could be extended inside the house if codes permitted, thereby saving whatever metal sewer pipes are being used. Plastic pipes could be used more extensively for waste and cold water lines. Plastic screen is a possible substitute for metal screen.

But the chief problem with plastic piping or plastic for other purposes is not how to use it but how to get it. Because plastics are being used for everything from radio cabinets to squeezable bottles, the supply of raw materials has been extremely tight. There will be even less when airplane and other military programs get into full production. Industrial users in the chemical, mining and petroleum industries are sure to want more. If the government should divert plastics from children's toys, radio and TV cabinets and other civilian uses to building materials there might be some additional material for a few construction uses. But almost no one believes this will happen.

The blunt truth is that neither plastics manufacturers nor the plastics trade association believe that their material offers possibilities or substitutes for critical items in building. There isn't enough material to go around now, and few manufacturers will take a chance on new products for such an uncertain market.

Many builders who have been providing refrigerators, stoves and other appliances believe these items will be such a headache they may have to be eliminated.

When shortages get really tough, a builder's best assurance will probably be putting up his houses in an industrial area where homes are needed for war workers. That would appear to be one of the few certainties in the whole uncertain picture.

(Continued on page 162)

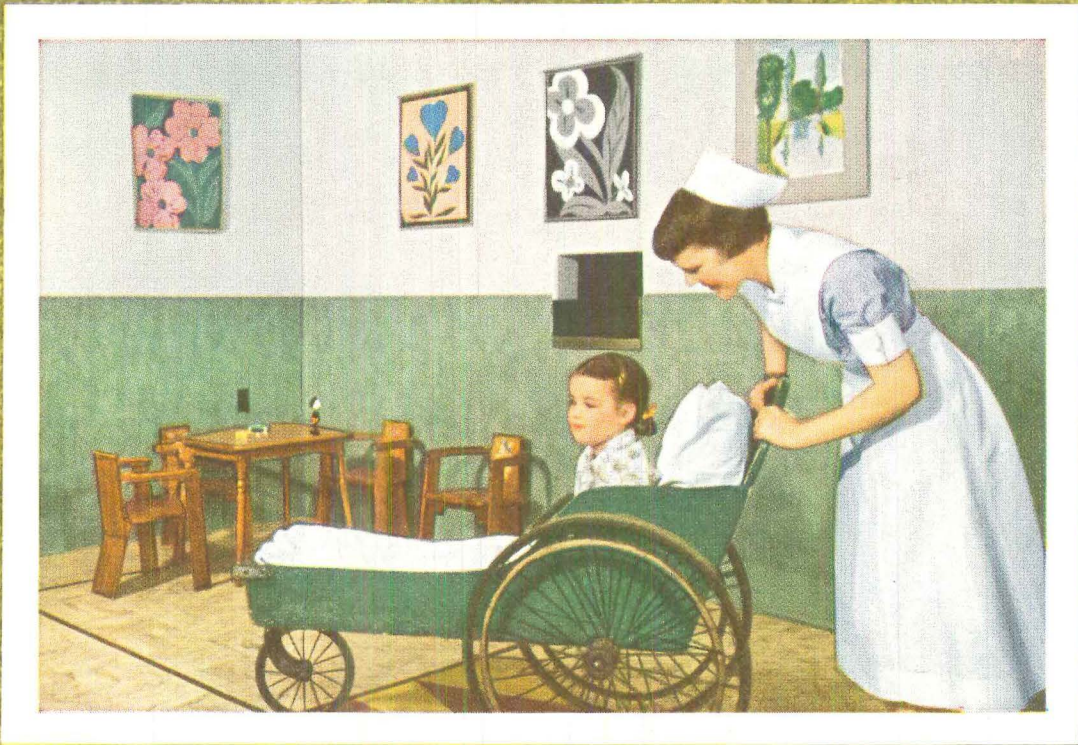

Nursery of the Children's Hospital, Pittsburgh. Wainscoting of Pastel Green Kalistron. Architect—Percy Stevens. Contractor—F. Hoffman Co. Installation—General Interiors Corp., Pittsburgh.

WHY THESE COLORFUL WALLS will **STAY** colorful . . .

Because these beautiful nursery walls are covered with Kalistron, they'll resist damage from spilled foods or liquids, from contact of rolling chairs or tables . . . *retain* their original glowing richness year after year. For exclusive Blanchardizing process fuses Kalistron color to *underside* of clear, extra-strength vinyl sheeting—thus color *can never show wear!* Suede-like backing adds further protection, permits easy bonding to wall surfaces.

Resistant to scratches, scuffs and spots, Kalistron won't chip, crack or peel.

Waterproof, yet easily cleaned with a damp cloth. *Winner of Modern Plastics Award for furniture and interior decorating materials.*

Coupon below will bring sample of Kalistron plus top-quality nail-file . . . free. See if you can injure Kalistron even with this file.

Kalistron
PAT. APPLIED FOR
← COLOR FUSED TO UNDERSIDE
PLASTIC COVERING MATERIAL

U. S. Plywood Corp., Dept. F-43
55 West 44th St., New York 18

Please send me FREE Nail-File Test (swatch of Kalistron plus actual nail-file).

NAME _____

ADDRESS _____

Distributed by: U. S. PLYWOOD CORPORATION, N. Y. C. and
by: DECO SALES, 408 Freylinghuysen Ave., Newark, N. J.
In Canada: PAUL COLLET & CO., LTD., MONTREAL

Color fused to
underside of
transparent vinyl
sheet . . . backed
by flocking

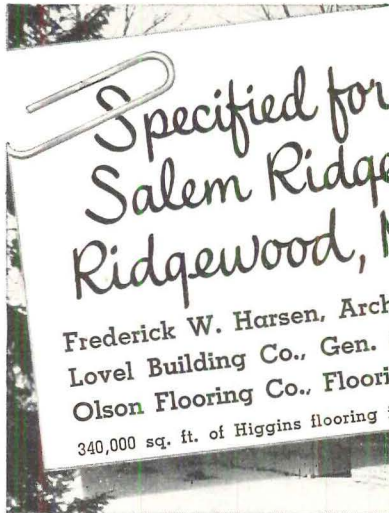

*Specified for
Salem Ridge,
Ridgewood, N.J.*

Frederick W. Harsen, Architect
Lovel Building Co., Gen. Contr.
Olson Flooring Co., Flooring Contr.
340,000 sq. ft. of Higgins flooring in 440 homes

HARDWOOD FLOORING

by *Higgins* WORLD-FAMOUS
BOAT BUILDERS

with Lifetime Beauty and Service

Higgins Bonded Hardwood Block Flooring will not warp, buckle, cup, or crack. It is rot proof, termite proof, water repellent, abrasion resistant, climate proof—especially quiet and comfortable to walk on.

Higgins Flooring is ideal over radiant heating. Grooves in the back of each block act as a heat conductor, assuring uniform heat with practically no increase in water temperature.

Higgins Flooring can be installed over any type of slab or any other subflooring. It can be blind nailed or laid in adhesive.

Keeps its luxurious beauty indefinitely with only routine housekeeping attention. You can always specify Higgins with confidence wherever distinction and permanence are desired.

Costs less laid down
Sells homes faster
Increases valuation

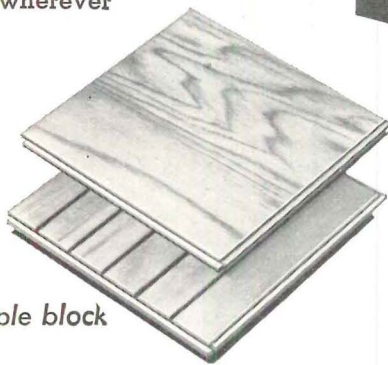

Write for literature and sample block

Higgins BONDED HARDWOOD
BLOCK FLOORING
INCORPORATED NEW ORLEANS

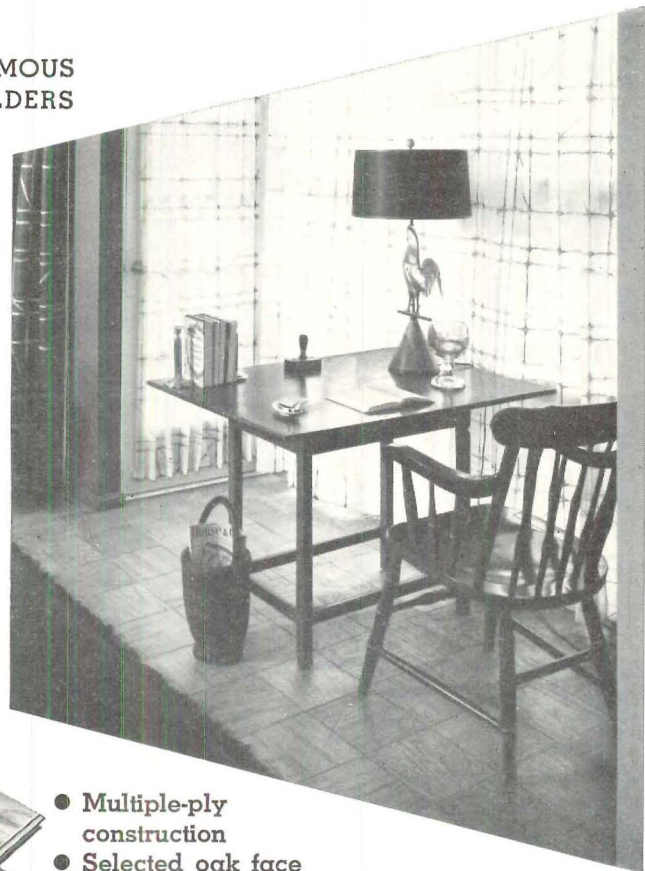

- Multiple-ply construction
- Selected oak face
- Pressure bonded with marine-type glue
- Integral tongues
- 9" x 9" net face
- Toxic impregnated—comes with final finish
- Grooved back molds to surface, anchoring into adhesive



Raymond conquers chubascos...in THE WORLD'S MOST UNUSUAL SOIL BORING JOB

FOR VENEZUELAN OIL CONCESSIONS, LTD.,

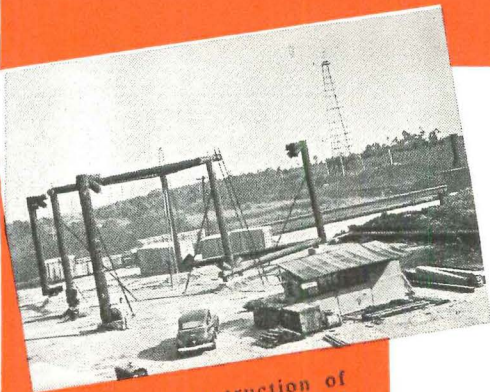

1. Construction of pipe frame float 30' high, 80' long on each side of the triangle.

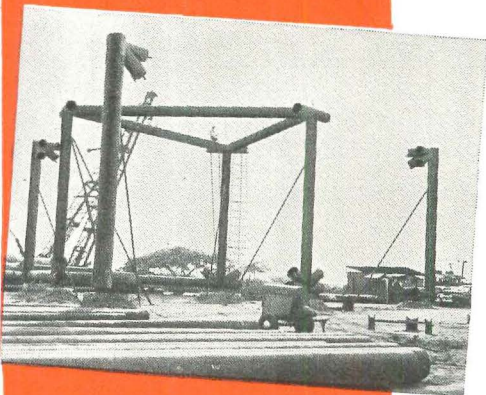

2. Closer view of the starting framework, showing 22" diameter steel pipe being used.

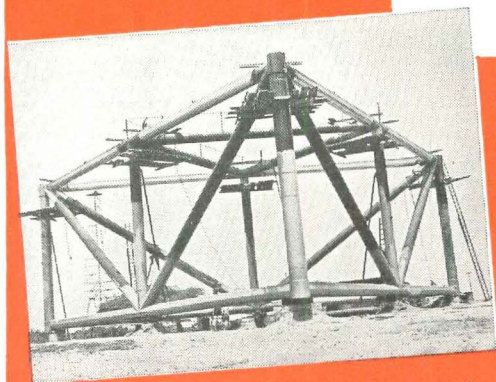

3. Completed framework, welded and watertight except for the corner verticals, which will accommodate anchor spuds.

The Problem: 250-foot Gow soil borings, accurately spotted five to ten miles offshore in the deep waters of Lake Maracaibo, Venezuela. The Project: pile foundations for future oil-well derricks. Special Hazard: 70-mile-an-hour "chubascos," violent squalls that would wreck temporary platforms.

The Solution: Raymond engineers designed a triangular floating platform of 22" steel pipe, welded and watertight. The three corner members were left open for 120-foot-long anchor spuds. Assembled on shore from steelwork fabricated in New York, the 60-ton float was skidded onto two barges and towed 32 miles to the first boring location where floating derricks launched it. Spuds and deck equipment were placed later, including winch-controlled anchors at each corner to help in spotting the float and holding it steady during boring operations.

The Moral: When the problem is tough, the answer must still be right. That's when it pays to have a resourceful, experienced organization on the job... like Raymond!

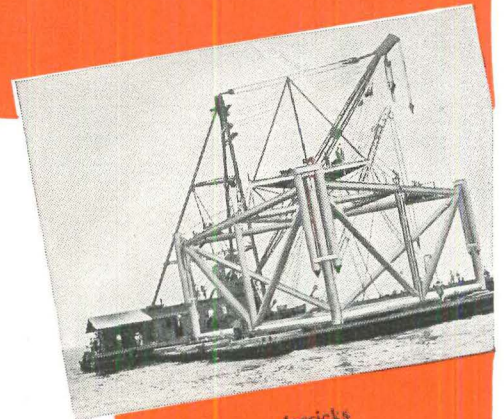

4. Floating derricks preparing to lift the float from barges and place it in the water.

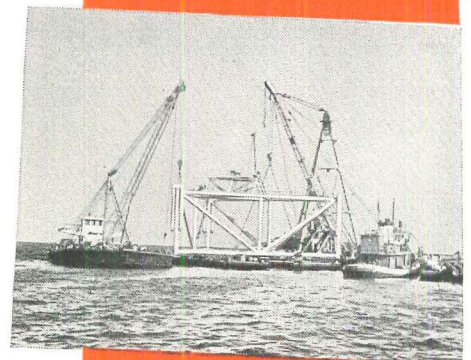

5. Launching the 60-ton float. Note work platform erected 10 feet above framework.

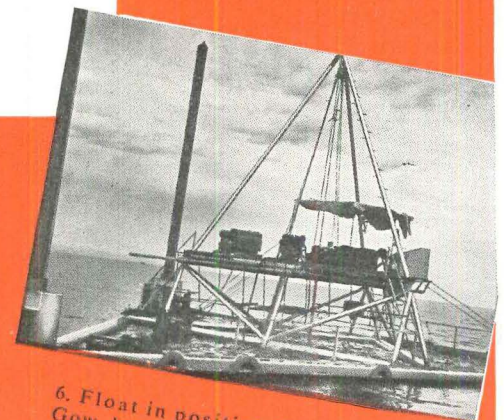

6. Float in position for Gow boring operations, anchored by the 120' spuds and cables at each corner.

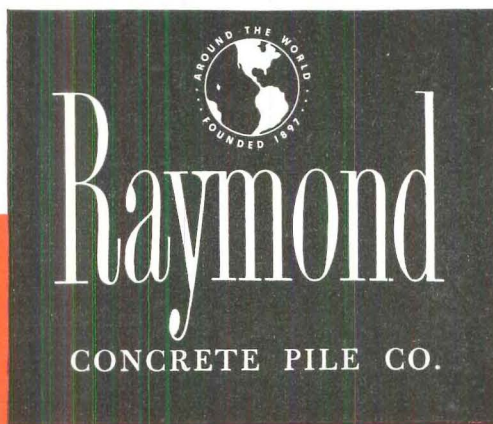

140 CEDAR STREET • NEW YORK 6, N. Y.

BRANCH OFFICES

Boston • Syracuse • Philadelphia • Baltimore
Washington • Pittsburgh • Atlanta • Miami
Houston • Kansas City • St. Louis • Cleveland
Chicago • Detroit • Salt Lake City • Portland
San Francisco • Oakland • Los Angeles
and principal cities in Latin America

THE SCOPE OF RAYMOND'S ACTIVITIES... includes every recognized type of foundation construction—concrete, composite, precast, steel, pipe and wood piles. Also caissons; underpinning; construction involving shore protection, shipbuilding facilities, and harbor and river improvements; borings for soil investigation; and cement mortar lining of oil and water pipe lines 4" to 144" in diameter by the Centrline Corporation, a Raymond subsidiary.

USF

MAKES STEEL DOOR HISTORY!

FIRST

TO DESIGN a 1 3/8" Hollow Steel Door that meets the ASTM-1 1/2 hour FIRETEST requirements and receive approval of the New York Board of Standards and Appeals.

FIRST

TO RECEIVE approval by the Underwriters' Laboratories, Inc. of a 1 3/8" Hollow Steel Door for "B" Label requirements.

FIRST

TO OFFER architects and builders a complete line of matching interior and apartment entrance doors;

It's the

USF

"Wooster Door"

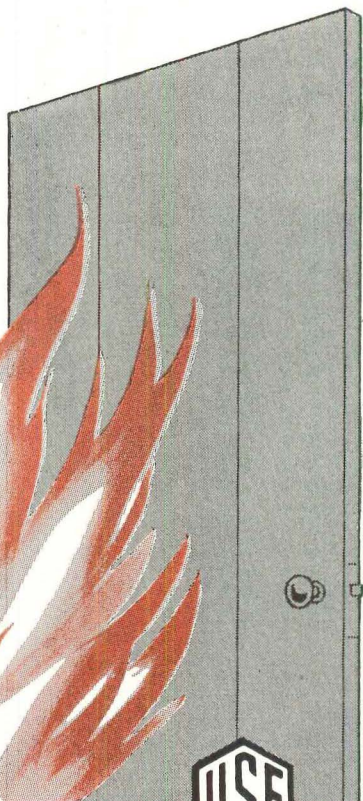

UNITED STEEL FABRICATORS, INC.

WOOSTER, OHIO

Manufacturers of HOLLOW STEEL DOORS, PORTABLE STEEL BUILDINGS, AND OTHER BUILDING SPECIALTIES . . .

WANTED: Substitute materials

(Continued from page 156)

How to save metal in air conditioning systems

Because air conditioning systems are almost entirely made of metal it would seem highly probably that builders would run into shortages of such equipment. The government might restrict the end-uses of air-conditioning equipment and forbid new installations in homes, stores, amusement places, non-critical offices and business establishments.

There is little doubt that regardless of how scarce metal becomes producers will be given priorities for air conditioning equipment for war plants in the South, shelters and other buildings that are all or partially underground. In areas where summer temperatures reach the 90's it has been proved that air conditioning keeps factory production rates high.

In a conventional air conditioning system metal in the central equipment (such as compressors, water chillers, and fans) is pretty well fixed and cannot be reduced. But a large proportion of all metal is in the ductwork and there are ways to reduce the amount.

Small ducts can be used, or fewer linear feet of ducts, or metal ducts can be eliminated altogether by substituting the pre-fabricated asbestos ducts mentioned earlier.

The use of smaller duct sizes was reported in two articles, in this magazine last year (July and September, 1950). Smaller ducts are satisfactory only if conventional air volumes are increased by stepping up velocities. This introduces other engineering problems of fans, reducing duct noises and of specially designed grilles that can handle high-speed without drafts. But solutions to these problems have been found.

Use of asbestos ducts

Since non-metal ducts were used during the last war with success in such conspicuous buildings as the Pentagon, it may be that the government will encourage this practice again. These ducts are of smooth, natural white asbestos and come in either rectangular or round shapes. The leading manufacturer of this product has solved the two knottiest problems: the way the ducts are assembled, and the construction of a wide variety of elbows, take-off members, other fittings and grilles.

Others are trying to save metal by using plywood or plaster rather than metal for furring in units installed under windows. Producers are now experimenting with reducing weight and thickness of all metals and are trying out plastic coatings for corrosion prevention rather than using the galvanized processes. Systems that do not use window units might possibly get preferential treatment from the government.

Metal can be saved in some air conditioning systems where air purification is a special problem by using activated carbon air recovery methods. The higher proportion of recirculated air that can be reused, the less fresh air has to be introduced and conditioned. In a sense, activated carbon filters help to manufacture fresh air. This is of greatest importance where odors are bad, or where there is very little air leakage, as in a windowless factory or an underground installation. It is conceivable that adequate air could be provided to an underground shelter for a large number of people with a much smaller air conditioning system if activated carbon were used than if it were not used. If this were done there would be a metal saving in fans, compressors and other such equipment.

Completely Installed
in
5 minutes!

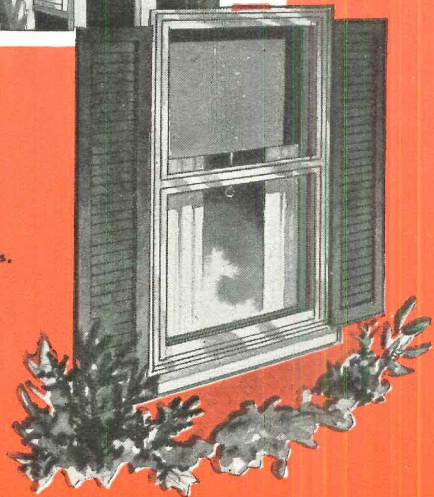
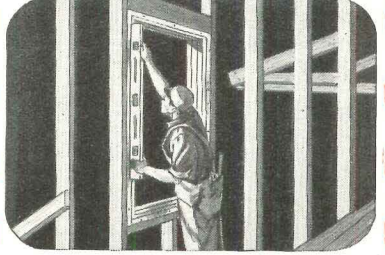
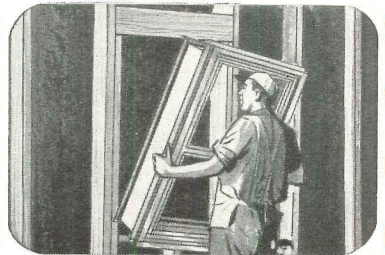
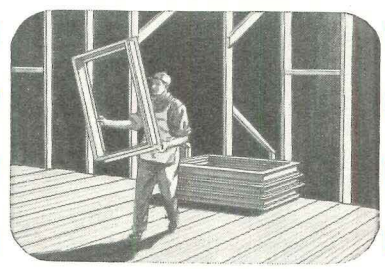

- Complete rainproof ventilation control.
- Automatic positive locking.
- Pay for themselves through fuel savings.
- Sturdy tubular construction.

No other window ever gave
you so much for so little

RUSCO



HOT-DIPPED GALVANIZED

PRIME WINDOW

(VERTICAL SLIDE)

FACTORY-PAINTED, COMPLETELY ASSEMBLED
... READY TO INSTALL

COMES COMPLETE WITH METAL OR WOOD
CASING (SURROUND)

DOUBLE GLASS, SCREEN & WEATHERSTRIPPING
IN ONE UNIT. (INSULATING SASH OPTIONAL)

A QUALITY PRODUCT COMPETITIVE WITH
LOWEST-PRICED UNITS

The Rusco Prime Window is the answer to each of the basic problems you face constantly. It gives you *unsurpassed quality at low cost*. It is made of *Hot-Dipped Galvanized Armco Ingot Iron Zincgrip*, Bonderized and finished with baked-on enamel. It *reduces installation cost and maintenance*. Rusco Prime Windows can be *installed in far less time* than ordinary window units. No field painting, no glazing, no hardware to attach, no on-the-job refitting. It's *complete . . . ready to install*. Get the full facts today. Call your local Rusco Prime Window distributor or mail the coupon below.

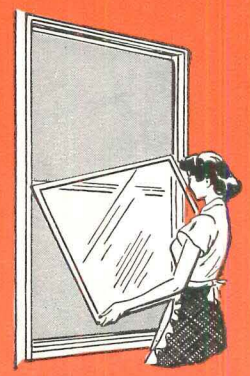

Panels easily removed from inside

The F. C. RUSSELL Co.

CLEVELAND 1, OHIO

Manufacturer of famous Rusco Armco-metal Combination Windows, Combination Doors, Porch Enclosures, Awnings and Jalousies



THE F. C. RUSSELL COMPANY

Department 7-MB11, Cleveland 1, Ohio

Gentlemen: Please send me catalog of informative data and specifications on Rusco Prime Windows.

Name Title

Company

Address

City Zone State

HOUSEBUILDER ATKINSON

(Continued on page 129)

demonstrate how much of the economic and social waste involved in big-city congestion can be offset by self-sufficient satellites.)

Since V-J Day, Midwest City has been expanding at the rate of 500 houses a year. Most of the tract's 3,600 houses have two bedrooms and a garage on a 60 ft. lot, sell currently for \$8,000. Each house differs from its neighbors mainly in the variety of porches, false gables and other tacked-on facade "treatments."

It is hardly Bill Atkinson's fault if the house designs at Midwest are no better than they are for he was one of the first big builders to realize the importance of better planning and design. In 1946, long before NAHB and the American Institute of Architects began their talks on improving builder-house design, Atkinson tried to interest Oklahoma City architects in bettering the design for local subdivision houses. After studying the problem, the city's architects and builders finally reached an agreement under which the architects offered to furnish sets of basic plans at 1 per cent of construction cost with a flat fee for each variations. The prospect for better builder's houses looked promising for a time, according to Leonard Bailey, the AIA local secretary, but it dimmed when architects' offices began getting more commercial and industrial jobs which offered bigger profits. Probably

the builders should have given more than 1 per cent. But perhaps the architects made a mistake in dropping the builders so quickly. If an Oklahoma City architect had developed a good basic house for Midwest City, for instance, he would have grossed between \$25,000 and \$30,000 on last year's production alone.

Atkinson himself still has not lost hope that he and other builders can do more business with local architects but he feels that they must change their attitudes first. Meanwhile, his design needs are handled by a staff architect.

Since 1946, most of the houses built at Midwest City have been partly prefabricated by the Atkinson organization in its own factory. Other builders operating in the tract are not required by Atkinson to use his prefab service but most of them do for the simple reason that it is cheaper, more efficient. The plant can produce panels for five houses a day, currently offers a choice of five basic floor plans and over 50 exterior variations.

New horizons for professors

The prefab operation and a half-dozen other Atkinson enterprises are run with clockwork smoothness by a remarkably flexible organization. Atkinson himself is seldom bothered with the details of any of the 43 corporations he has

set up to carry out the operation. "I simply put someone I trust in charge of each operation, then let them alone as long as the monthly financial statements are all right." Besides his housebuilding operation, Atkinson operates a lumber yard, an electrical company, a plumbing concern, and a hardware store—all of which do a big retail business. (Strangely enough, they do very little business with the housebuilding section of his own organization. Thus, Atkinson the hardware man seldom sells Atkinson the housebuilder any fixtures because Atkinson the foxy buyer can often beat his own prices.) In addition, he has a commercial building division and a shopping-center development company.

For a builder, Atkinson has made some highly unorthodox choices in selecting the men who run his various operations. His construction superintendent, Howard Thornton, was a teacher at Oklahoma City University. "Howard didn't know much about how a house goes together but he knows how to organize." Like other key personnel in the organization, Thornton is given a direct share of his operation's profits. (In his case, 10 per cent.)

Cokes and Dr. Pepper

For all his promotional and executive flair, Atkinson
(Continued on page 166)



Obvious Beauty

Proven Economy

Certified Quality



STEEL WALL TILE

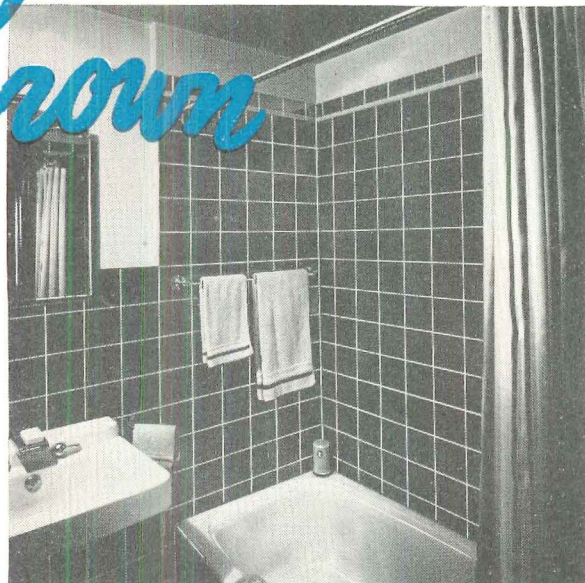

Many thousands of Crown Steel Tile installations across the nation are eloquent evidence of the warm reception given Crown Tile by scores of hard-headed builders.

Their "brass tacks" investigations showed them that there is no more beautiful tile than Crown Tile; that for original cost and long-term utility, Crown Tile has no rival; that for black-and-white proof of quality, no other tile can match Crown Tile's guarantee, bonded by National Surety Corporation.

Crown Tile welcomes your most critical investigation, too. You're sure to see why it's the successor to, not a substitute for, ordinary wall tile.

guarantee
bonded by



THE OHIO CAN & CROWN CO.
MASSILLON, OHIO

★ FOR MORE INFORMATION SEE
OUR CATALOG IN SWEET'S
1951 ARCHITECTURAL FILE

HALL-MACK QUALITY ACCESSORIES

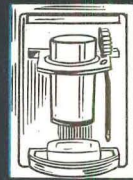
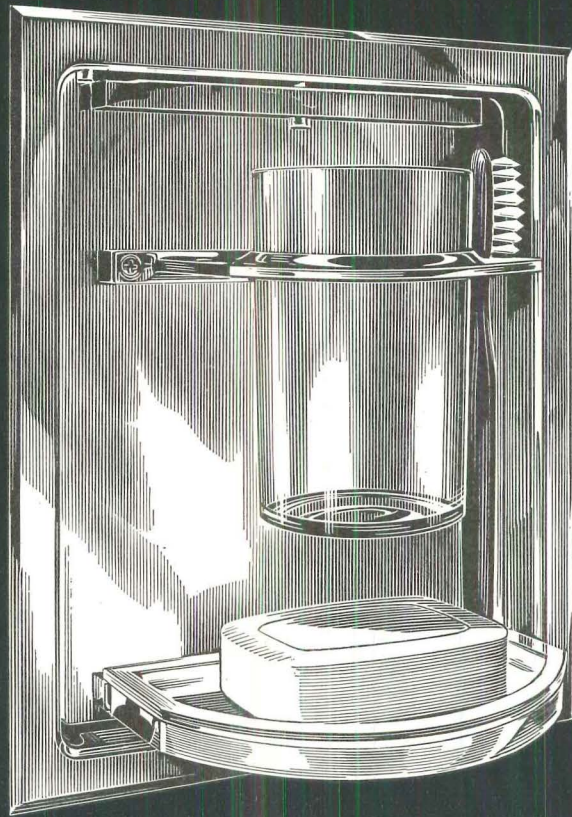

...for every bathroom style and budget

Line for line, piece for piece, Hall-Mack Bathroom Accessories give you extra style and construction. This Concealed Lavatory Unit, for example, is an exclusive Hall-Mack Accessory that combines distinctive modern style, utmost convenience, and finest construction throughout. And you will find similar

quality carried through in every bathroom accessory made by Hall-Mack.

Regardless of your bathroom budget, Hall-Mack Quality is never out of reach.

HALL-MACK®

HALL-MACK COMPANY

1344 W. Washington Blvd., Los Angeles 7, Calif.
7455 Exchange Avenue, Chicago 49, Illinois

Bathroom Accessories Are Important

Since you build a bathroom for a lifetime of use—
make sure you get Hall-Mack's lasting style and quality.

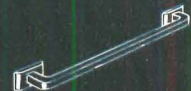

New "Controlled Humidity" Method Gives a Better Solution to Air Conditioning Problems

"Hygrol" Absorbent Liquid Dehumidifies Fresh Air Without Refrigeration

NIAGARA Air Conditioners or Dehumidifiers using "Hygrol" liquid absorbent give precise control of air temperature and humidity... at lower operating cost, with large savings in space and with smaller and less expensive equipment, in many applications.

This method dehumidifies the air by passing it through a chamber in which "Hygrol" spray removes its moisture and produces a low dew point. The "Hygrol" solution resulting is continuously and automatically re-concentrated, providing always full capacity in

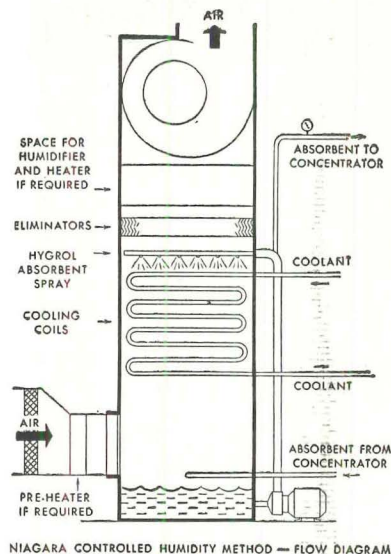
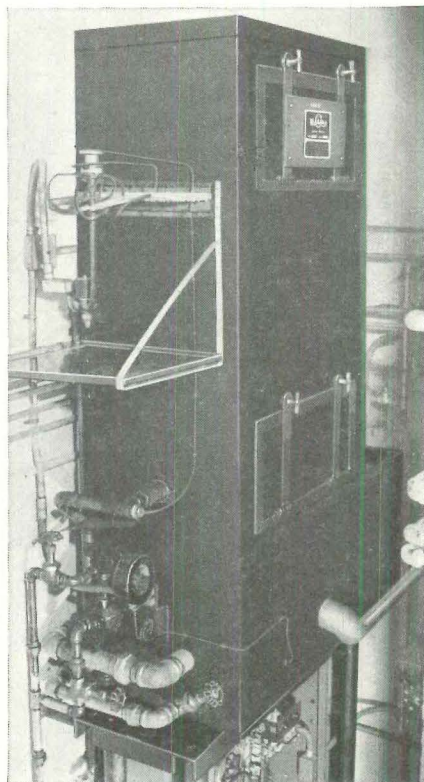

Write for Bulletin 112

NIAGARA BLOWER COMPANY

Over 35 Years Service in Industrial Air Engineering

Dept. AF, 405 Lexington Ave.

New York 17, N. Y.

Experienced District Engineers in all Principal Cities

air conditioning and assuring always a constant dehumidifying capacity and a trustworthy, constant condition for your material, apparatus, process or room to be conditioned.

"Hygrol" is a liquid, not a salt solution; it stays pure and non-corrosive; it does not cause maintenance or operating troubles in food plants or in chemical processes.

Investigate this new Niagara Method for "comfort" air conditioning as well as to protect quality in hygroscopic material, or processes or instruments, or to prevent condensation damage to metals, parts or products.

HOUSEBUILDER ATKINSON

kinson himself is a remarkably unassuming person. He lives quietly in the small house downtown—the one that got him into the building business during the depression—with his wife Ruby and two daughters, Eugenia Ann, 16 and Jeanette, 14. A 21-year-old son, William Joseph, is married. Atkinson is a non-smoker, a self-consciously mild swearer and a teetotaler. (Standard crack: "Bill's office has the only built-in bar in Oklahoma that serves Coke and Dr. Pepper exclusively.") After the war, he bought a 160-acre farm adjoining Midwest City which he has renovated as a retreat for his family and a place to entertain guests.

Unlike many newly-rich Oklahomans, Atkinson did not turn to cattle raising—a business he knows nothing about. His specialty is Shetland ponies—an unashamed throwback to Billy Atkinson, aged nine, back in Carthage, Texas, who didn't get the pony he wanted for Christmas. He has about 175 ponies on his farm, including two prize stallions reportedly worth about \$5,000. A pet Atkinson project is the use of his ponies to counteract any trace of juvenile delinquency at Midwest City. He is setting up a "Midwest City Pony Club" as an honor society for the town's teenagers. Membership is limited to 50 and each member will be assigned one of the ponies. Atkinson is confident that every kid in town will want to get into the club, and thereby observe its prerequisite of staying out of trouble.

Some political symptoms

Atkinson is deeply interested in Oklahoma politics. He is a big enough power in the State Democratic Party to be considered an active candidate in the 1952 gubernatorial campaign. For his own part, he has shown an Eisenhower-like adeptness at dodging the question. Most local political pundits agree on two points, however: first, that he stands a fairly good chance to get the nomination and, secondly, that he is showing definite symptoms of being a man who wants it. Atkinson's political astuteness may be measured by the fact that, in his 20 years' active service to the party, he has never backed a losing candidate. This record is almost unique for Oklahoma where Democratic Party primaries—usually the only elections that count—tend to be highly factionalized at times. His latest success was in supporting, during both the primaries and general election last year, his great-and-good friend, Mike Monroney, for U. S. Senator. Atkinson was co-chairman of the State finance committee—a key post in a state where campaign financing is done with large checks rather than the nickels and dimes of the party faithful.

Atkinson first came to national prominence in NAHB as chairman of its legislative committee during 1949. This was the year in which the Homebuilders and other real-estate organizations lost their fight against the public housing bill. In the battle of the lobbies which preceded the bill's passage, Atkinson had the job of mobilizing the builders throughout the country for local

(Continued on page 170)

Scranton, Pa., Builds for the Future
with **LIGHT-WEIGHT**
EASY TO INSTALL
J & L JUNIOR BEAMS

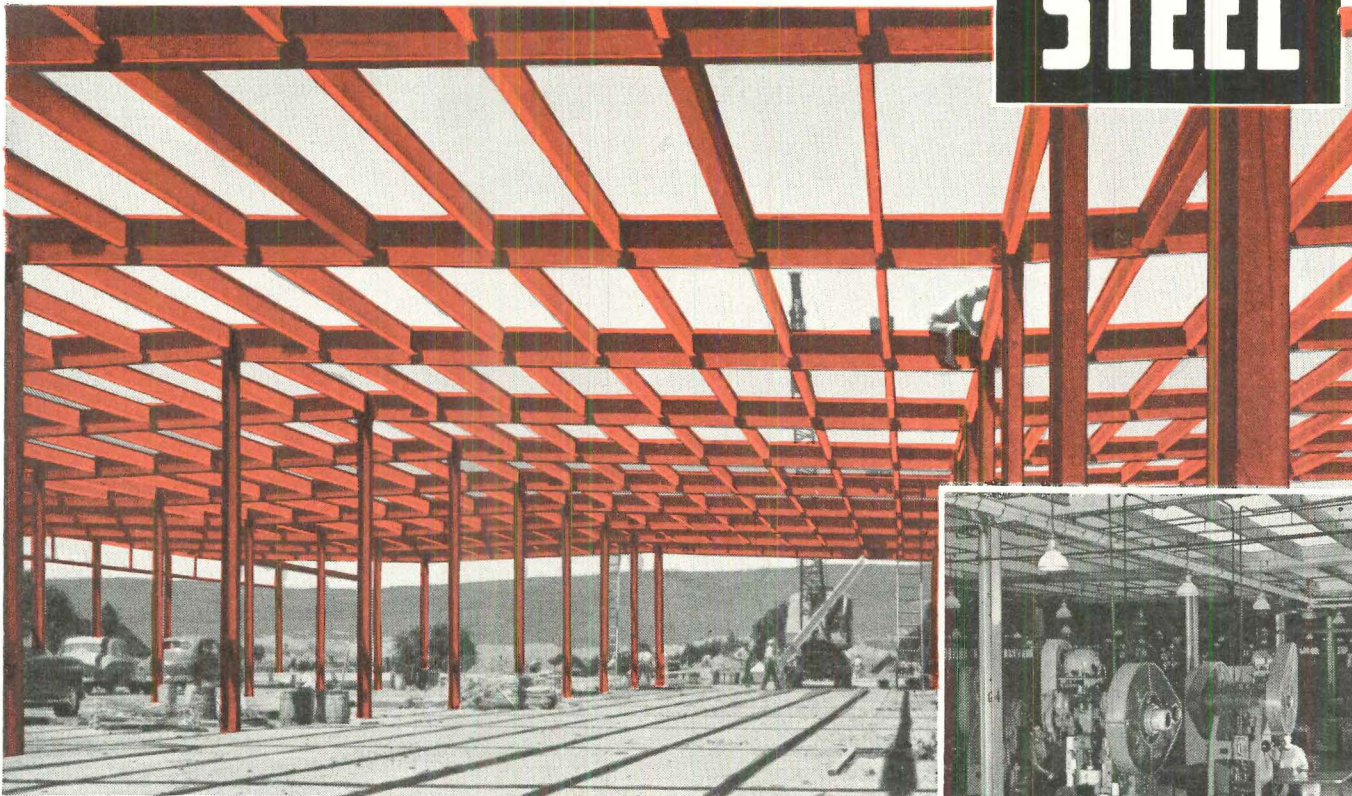
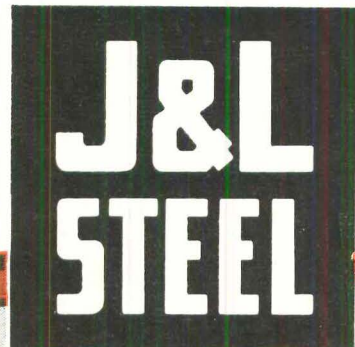

A typical example of steel framework in one of the LIFE plant buildings. Junior Beams contribute vitally to the ease and speed of construction.

**JUNIOR BEAM ROOF PURLINS SAVE TIME AND MONEY
IN CITY'S PLANT CONSTRUCTION PROGRAM**

The citizens in the area of Scranton, Pa., have embarked on a farsighted program of industrial plant construction. They call it Lackawanna (County) Industrial Fund Enterprise—LIFE. Its aim is to attract new industries which will provide the district's unemployed with sorely-needed jobs.

Early in the program, the Anthracite Bridge Company, Scranton, worked out an economical building system which has been used in almost every new plant erected.

J&L Junior Beams play an important role in making this low-cost, speedy construction possible.

For example, in Building No. 1 of LIFE's program light-weight Junior

Beams were installed as roof purlins. A five-man crew with a light truck-crane plus another five-man "bolt-ing-up" crew erected the entire steel framework of the 180' x 460' building *in less than 10 days!*

The uniformity of Junior Beams made them readily adaptable to variations in design, and their ease of handling further speeded construction—two factors that *saved time and money on the job.*

Junior Beams, produced exclusively by Jones & Laughlin Steel Corporation, are easy to install, require no fabrication other than end connections and bolt holes. They are rigid, vibration resistant, shrink proof, and have a lower de-

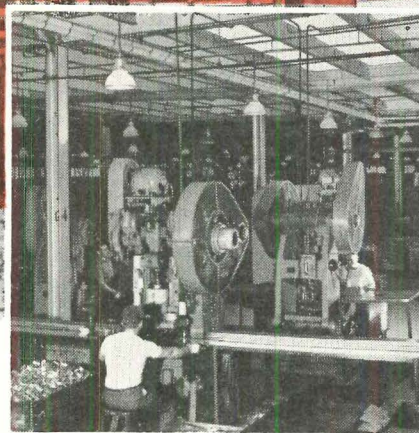

Interior view of completed plant occupied by the Eastern Mfg. Div., The Trane Co., showing Junior Beam roof purlins in the economical ceiling construction.

flection factor than other structural sections of equivalent weight.

Why not write today for our new booklet: "Skyscraper Construction for Every Building?" It shows how Junior Beams are used as floor joists, and roof purlins with erection details, specifications, loading and spacing tables.

Jones & Laughlin Steel Corporation
401 Jones & Laughlin Building
Pittsburgh 30, Pa.

Please send me a copy of the booklet entitled, "Skyscraper Construction for Every Building."

NAME _____

COMPANY _____

ADDRESS _____

JONES & LAUGHLIN STEEL CORPORATION

From its own raw materials, J&L manufactures a full line of carbon steel products, as well as certain products in OTISCOLOY and JALLOY (hi-tensile steels).

PRINCIPAL PRODUCTS: HOT ROLLED AND COLD FINISHED BARS AND SHAPES • STRUCTURAL SHAPES • HOT AND COLD ROLLED STRIP AND SHEETS • TUBULAR, WIRE AND TIN MILL PRODUCTS • "PRECISIONBILT" WIRE ROPE • COAL CHEMICALS

CRANE

the preferred plumbing

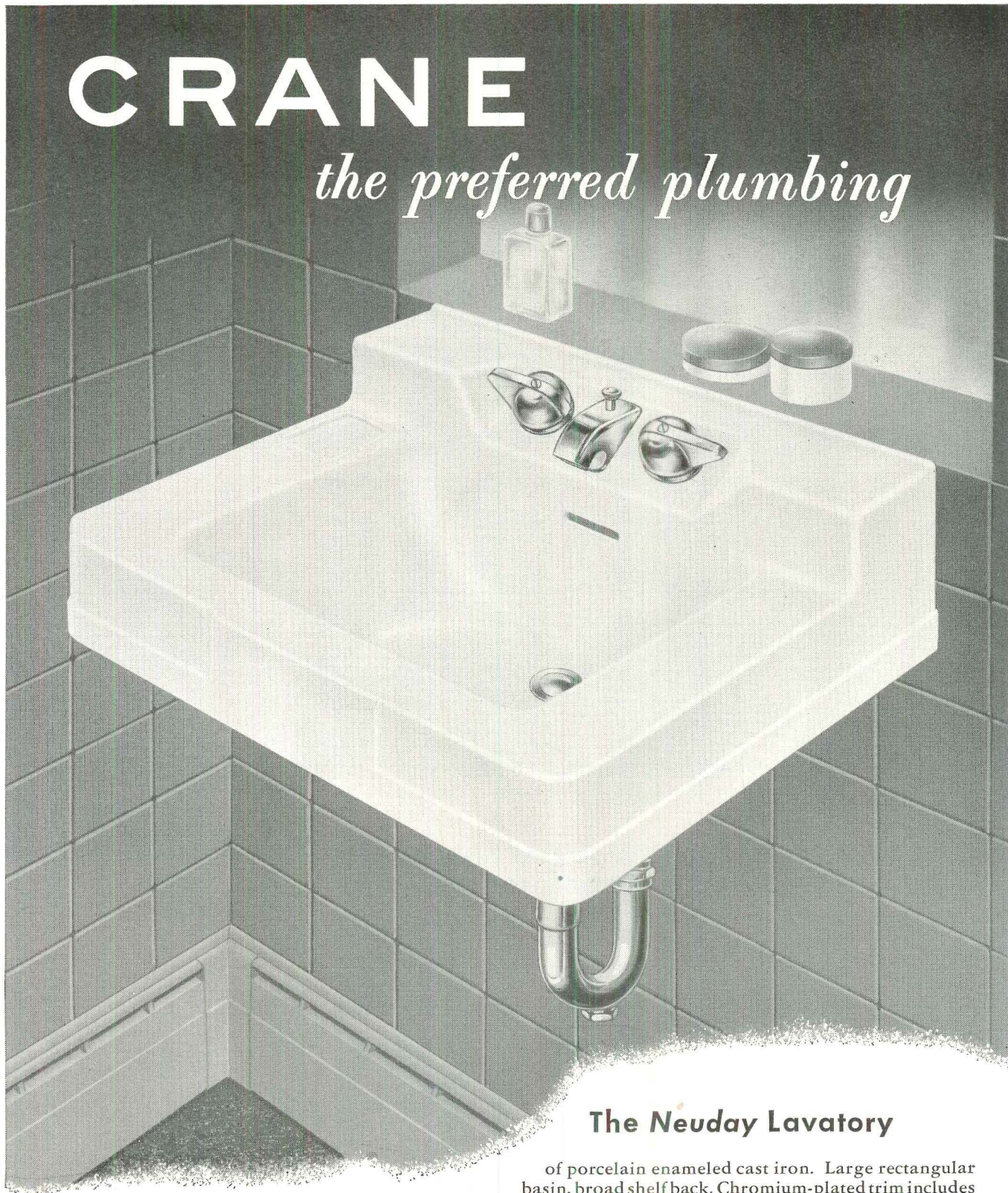

CONSULT YOUR CRANE BRANCH OR
CRANE WHOLESALER FOR INFORMA-
TION ON THE COMPLETE CRANE LINE.

The Neuday Lavatory

of porcelain enameled cast iron. Large rectangular basin, broad shelf back. Chromium-plated trim includes Crane *Dial-ese* controls, conveniently located on beveled panel. Twin towel bars and legs available if desired. Sizes: 19 x 17 and 24 x 18. Made in regular white enamel, acid-resisting white enamel and 8 colors.

CRANE

CRANE CO., GENERAL OFFICES:
836 S. MICHIGAN AVE., CHICAGO 5

PLUMBING AND HEATING
VALVES • FITTINGS • PIPE

Your clients want the CONVENIENCE of

Nepcoduct-

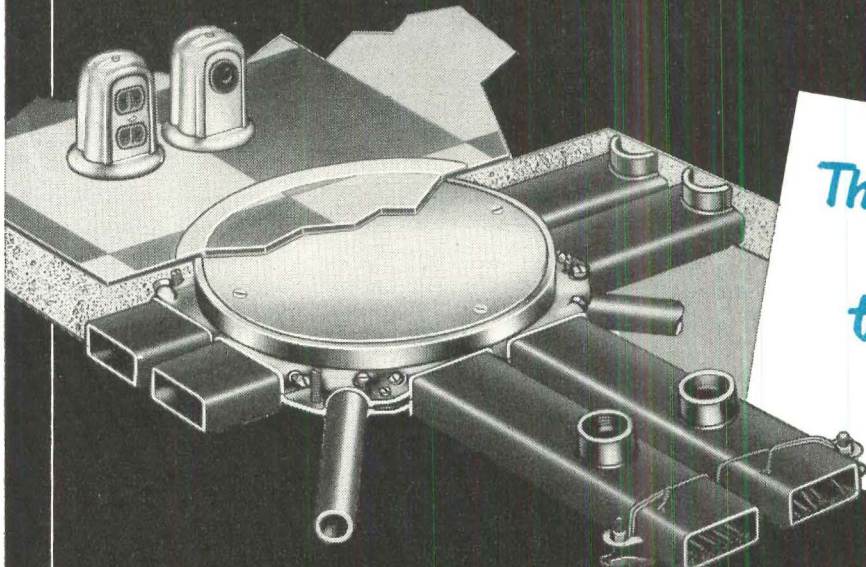
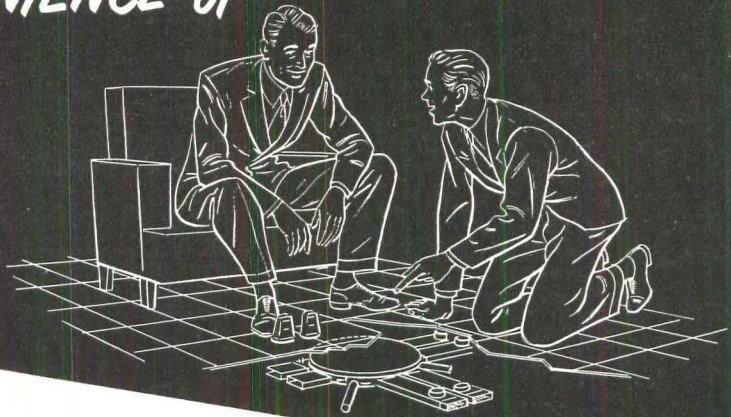

The STANDARD underfloor wiring system that fits any type of floor construction

7904-HL

Nepcoduct is a simplified steel raceway system—the most efficient and economical method of providing convenience outlets, wherever needed, at the floor surface. It may be used as a single, double or triple duct system, providing separate wiring facilities for light and power, signal circuits, communication and telephone.

Nepcoduct eliminates unsightly and dangerous extension cords . . . keeps walls and ceilings free of outlets . . . permits flexible office layouts.

BUILDING OWNERS want Nepcoduct because it provides tenants with all the electrical service they will ever need, without cutting building structure or routing concrete. TENANTS want Nepcoduct because outlets are quickly, easily installed anywhere without interrupting office routine. ARCHITECTS and ENGINEERS want Nepcoduct because it fits any floor construction, reduces cost of electrical extensions and maintenance.

Steel for Permanence . . . Grounded for Safety.

EVERYTHING IN WIRING POINTS TO

National Electric
PRODUCTS CORPORATION
PITTSBURGH, PA.

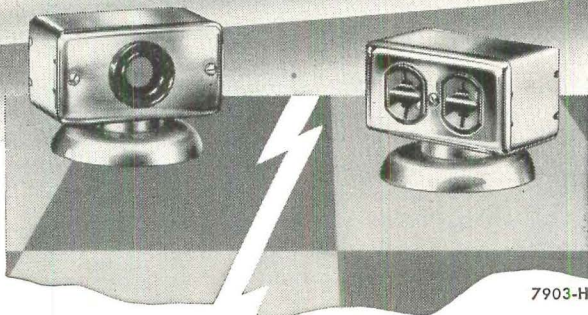
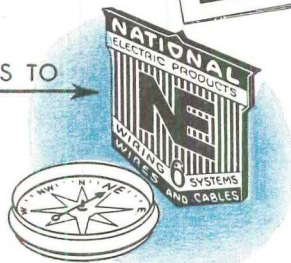

New
STREAMLINED SERVICE FITTINGS

Two new chrome plated service fittings designed to add dignity and beauty to the modern office. 7903-H for high potential light and power. Will take any type of standard duplex receptacle. 7904-HL for low potential telephone and communication wiring.

Free

Write today for the new Nepcoduct catalog. This coupon will bring you a copy.

National Electric Products Corporation
1334 Chamber of Commerce Building
Pittsburgh 19, Pennsylvania

Please send me the illustrated Nepcoduct catalog.

Name.....

Title.....

Company.....

Address.....

Speed and Simplify BUILDING

with "Safety-Sealed" Saf-Aire
Gas Heating Units

Gain Valuable floor space!

Free your designs from chimney limitations!
Avoid expensive central heating installation!

When you specify "Safety-Sealed" Saf-Aire units you combine safety and dependability with real economy. These attractive, space-saving Saf-Aire units require no chimney, no ducts, no electricity. Bring important installation savings.

Quickly, easily installed in any exterior wall, Saf-Aire provides healthful, even, "zone-controlled" heat with either natural, manufactured or LP gas. Assures positive safety, too, for no room air is used for combustion.



Chooses SAF-AIRE For 1500-Home Project

Mr. Barney Katzman, President of Detroit's Prudential Investment Company, says: "Important savings of space and simplification of individual home design are the two main reasons we picked Saf-Aire. We also count on their positive safety and convenient zone-heating control to be big assets in the sale and rental of these homes."

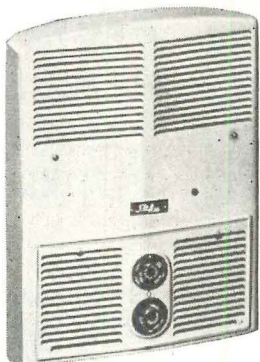

SAF-AIRE wastes no floor or closet space. The all-aluminum interior panel extends only 4 inches from wall surface. Connects directly to the small Lundstrum Vent on the exterior wall. Simple, modern design suits any interior. Both 14,000 and 20,000 BTU capacity models are available in 3 attractive finishes.

Model 991-14
18" x 24"

Model 992-20
18" x 38½"

ONLY SAF-AIRE . . . has the patented exterior wall vent that draws all combustion air from outdoors, then vents all combustion products outside for dissipation.

Approved by American Gas Association. Also listed by Underwriters' Laboratories and accepted for Veterans' Housing and F. H. A. financing.

WRITE NOW for complete free information and specifications on this latest development in modern gas heating. Mail coupon below today!

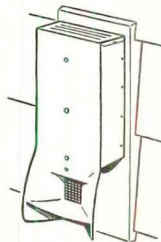

Exhibitor



Home Builders and Allied Interests—Visit Our Display, Booth 40

STEWART Warner
DOMESTIC HEATING

Stewart-Warner Corporation, South Wind Division
Dept. MB-11, 1514 Drover Street, Indianapolis 7, Indiana

Please send me specifications and complete details on "Safety-Sealed" Saf-Aire Gas Heating Units.

Name _____

Address _____

City _____ Zone _____ State _____

**MAIL
COUPON
TODAY!**

HOUSEBUILDER ATKINSON

political action. In the last days of the fight, he reportedly had over 1,000 builders probing around Capitol Hill for Congressmen who still weren't sure whether it was good politics to vote for or against the bill. (By contrast, the public housers are said to have mobilized only 600 of their people.)

The bill passed by three votes. The public housing groups have since declared that the vote was so close that they would have been glad to compromise on a milder measure if the opposition had been willing. Atkinson still believes that NAHB was correct in refusing even a feeble public housing bill. Says he: "The whole history of subsidized housing is that when you give the government planners an inch, they'll take a mile."

However, public housing will be a relatively minor problem compared to the war-spawned situations which face Atkinson if he heads NAHB during the coming year. Atkinson recalls that some of the greatest difficulties he and other builders had back in the early defense-housing period of World War II came from their lack of an agency of their own through which they could tell the government what they had to offer or to find out what the government needed. He hopes that NAHB, which was set up in 1943, will be able to clear out this underbrush of confusion between the builders and the government planners of the new war economy. "Nothing is more important, of course, than that our industry be ready at all times to deliver whatever housing the government needs where it is needed."

If, by some wonderful coalition of events, the war crisis should end during his NAHB presidency, Atkinson may be able to devote more time to a pet peacetime project he is planning for the 1,200 undeveloped acres on the outskirts of his town. Briefly, it is a ranch house to end all ranch houses. It has always pained his Oklahoma soul to put houses on little lots when there is so much space available. His new idea is a house on a half-acre tract with room for a chicken coop, a garden patch and maybe even a place for a pony. He has yet to figure out how he can market such a house at a price an average family can afford but he's working on it. It would be typical of Bill Atkinson to develop the first community whose house mortgage covered chickens and a pony as well as the kitchen range.

C. E. Redman



One of the perils of being a trade-association officer—induction into the local Indian tribe. Above, Atkinson at a homebuilders banquet in Albuquerque last year when he was NAHB's first vice president.

Easier Painting With Removable Sash



All R·O·W sash can be quickly removed from their frames, stacked, and prime coated at one time.

Shortens priming, exterior and interior painting time, cuts painting costs. Then sash may be covered and stored until danger of breakage is past.

See R·O·W at Booth No. 81, N.A.H.B. Show, Chicago, January 21-25.

LOCALLY MANUFACTURED TO MEET LOCAL REQUIREMENTS



R·O·W windows are manufactured in 27 and distributed in 48 territories throughout the U.S. Each of these local manufacture-distributors produce windows specially designed to meet the requirements of your locality.

For the name of your nearest distributor and your free copy of R·O·W's "Window Washing Time Study" —fill out the coupon at right.



R·O·W SALES COMPANY

1326 ACADEMY • FERNDALE 20, MICHIGAN



PLEASE Send more information on R·O·W—the window with sales appeal.

Name _____ I am Architect
 Company _____ Builder
 Address _____ Dealer
 City _____ Zone _____ Carpenter-Contractor
 State _____

SOLD



1. Wall Cabinets
2. Range Pantries
3. Refrigerator Pantries
4. Utility Cabinets
5. Kitchen Radios
6. Base Cabinets
7. Electric Ranges
8. Shelvador® Refrigerators
9. Home & Farm Freezers
10. Sinks and Garbage Disposers

SOLD

SEE WHAT CROSLY-EQUIPPED KITCHENS CAN DO FOR YOU... **FAST!**

You can sell prospects quicker when more kitchen equipment is included in the package mortgage... and rentals with modern, worksaving kitchens never lack tenants.

A Crosley-equipped kitchen provides

better, easier living from the prospect's point of view. From *your* point of view, Crosley products installed in the kitchen mean easier selling or renting—today, tomorrow and ten years from now.

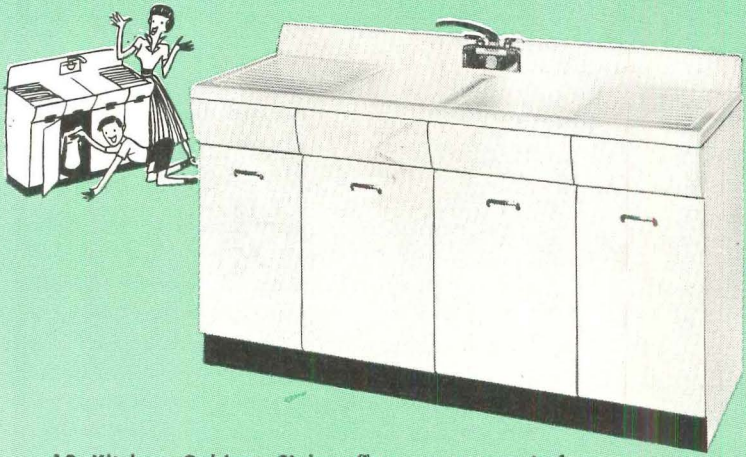

10 Kitchen Cabinet Sinks offer you a practical selection: Right- or left-hand drainboard . . . one drainboard or two . . . double or single bowl . . . Custom or De Luxe Models.

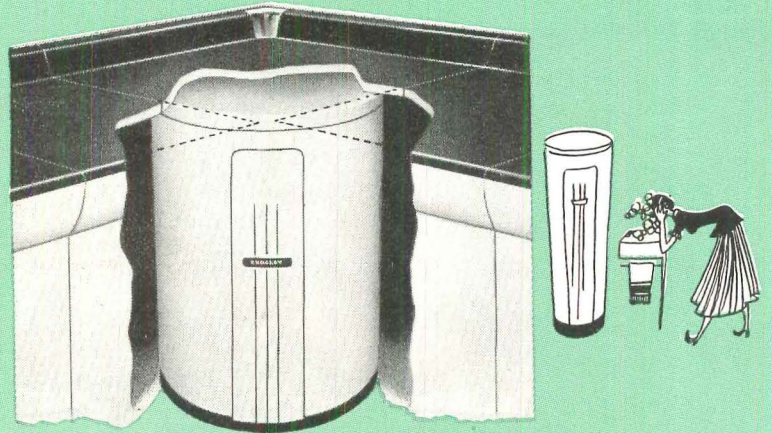

Today's building costs demand modern water heaters! Crosley Corner and Table-top Water Heaters save dollars because they save space. Round Models also available to offer you a complete line.

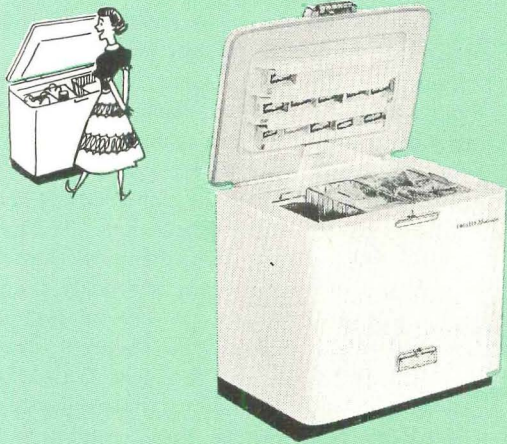

Freezers are becoming more and more indispensable to modern housewives. That's why progressive architects and builders are incorporating freezers in the houses they plan and build.

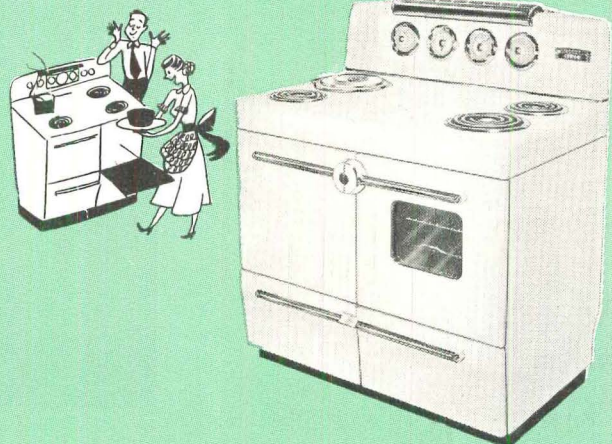

Crosley's Electric Ranges increase home value with smart innovations in automatic cooking. Double or single ovens . . . "cluster" or "divided" tops. 9 models including two apartment types are available.

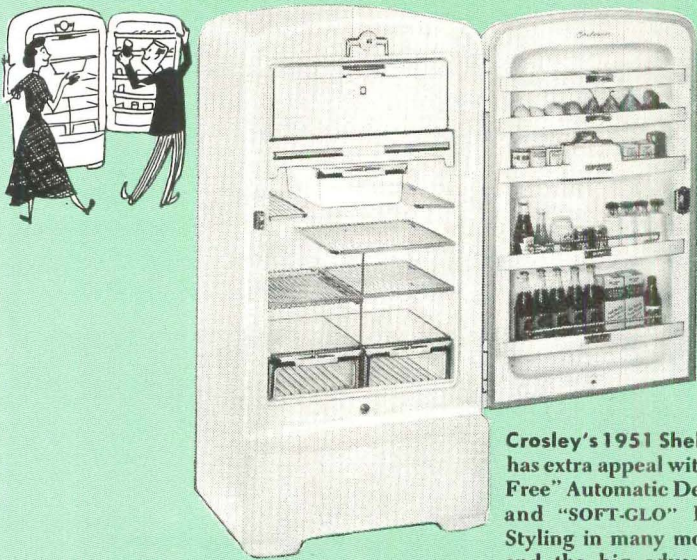

Crosley's 1951 Shelvador® has extra appeal with "Care-Free" Automatic Defrosting and "SOFT-GLO" Interior Styling in many models . . . and the big advantage of twice as much "front-row" space. 11 models, including apartment types.

Free booklet available to architects and builders. For information or booklet, write: Builder Sales, Crosley Division, Avco Manufacturing Corporation, 1329 Arlington Street, Cincinnati 25, Ohio.



Electric Garbage Disposers with Crosley's patented mechanism won't clog or jam . . . will fit practically any sink with a 3½" to 4" drain opening.



Matching Base Cabinets are available in many sizes and styles making it easy for you to plan kitchens exactly the way you want them.

Steel Wall Cabinets, available in a complete variety of sizes, have handsome, long-lasting baked enamel finish to match Crosley appliances.

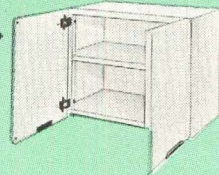

Crosley Division



CROSLEY
Better Products for
Happier Living

REVIEWS

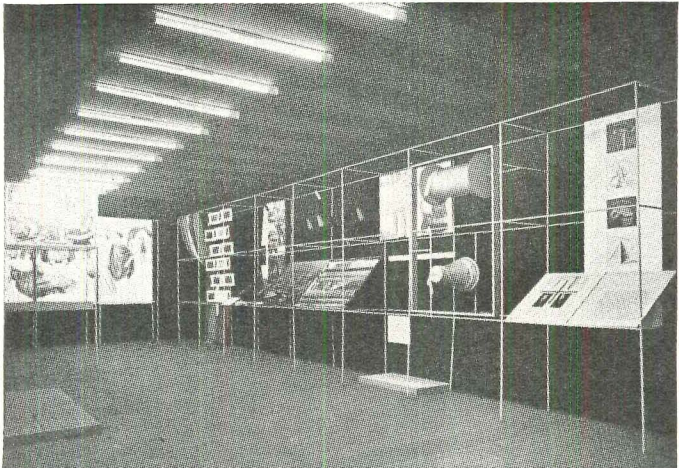

A rectangular aluminum skeleton allows the viewer to examine stages in the development of wool cloth. (By Eric Brown & Stefan Buzas.)

Globe, wall maps and three-dimensional chemical symbols dramatize nitrogen research at the 1949 Milan Fair.

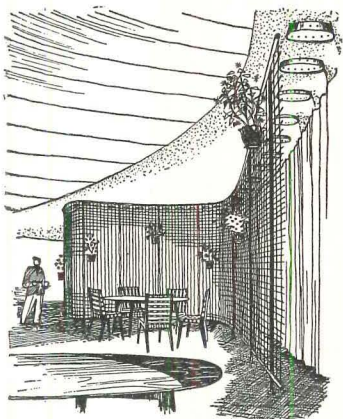
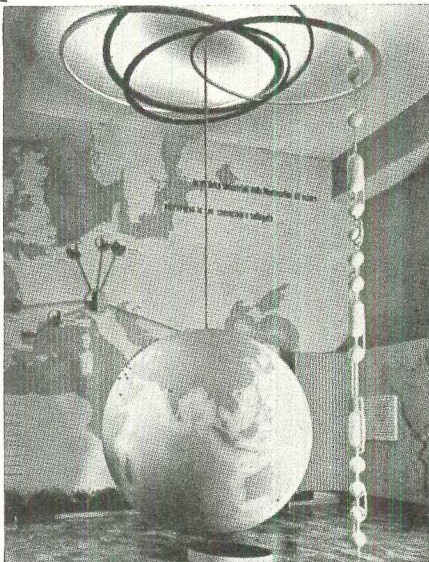

Steel mesh, scaffold tubes and flower pots created this restaurant wall at Enterprise Scotland in 1947. (By Basil Spence.)

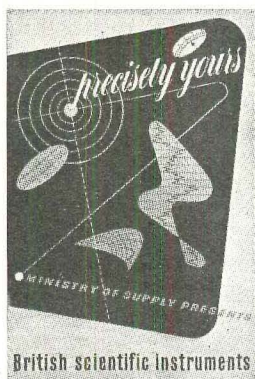

Poster by Robin Day (left) is an expert combination of design and typography—essentials of any propaganda show.

Jet Exhibition (below) blends two- and three-dimensional effects. Center of the stylized jet is an 'impellor' motor in operation.



The outdoor stand (below) was designed for dismantling and re-erecting at fairs in various parts of the country. Its framework of steel tube and rods is covered by a roof of corrugated steel, and a canvas front. (By Alexander Gibson and Mischa Black.)

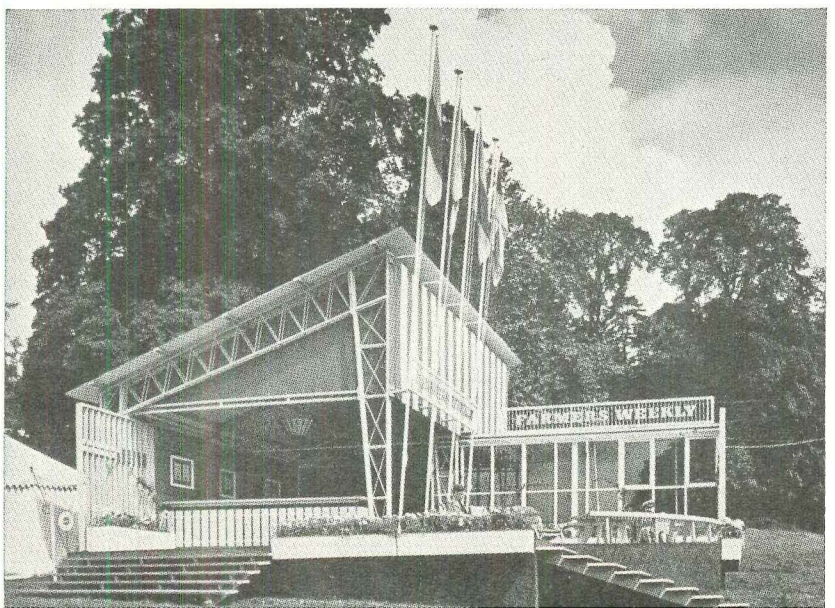

EXHIBITION DESIGN edited by Misha Black. The Architectural Press, 13, Queen Anne's Gate, SW1., London, England. 186 pp. 7¼ x 9¾. Illus. 25 shillings.

"The task of every exhibition is to sell something, whether it is a new line of tea-pots or a plan for the regeneration of Western civilization." The English, who in the last ten years have developed exhibit design to a fine art, present here the theories and methods which underlie their very skillful practice. Contributions by ten prominent exhibit designers combine to form the best and most practical summary of the craft yet published. Its success is due to a high degree of cooperation in all aspects of the field—design, techniques, finance. Included in its scope are trade fairs, public exhibits, propaganda exhibits, traveling shows, national and international exhibits.

Editor Black and his associates consider the purposes for which exhibits are best used, and those for which they are not suitable. Expense is a deciding factor here. Exhibits, as the most expensive means of propaganda—"are only the most satisfactory means for sales, education or propaganda when they are concerned with actual physical objects or demonstrations . . . The medium is only properly used when physical objects can point the moral more effectively than the spoken or written word . . . The interest of the subject should preferably be captured by three-dimensional objects and then lead to two dimensional material. A simple poignant object placed in a bare room can be better exhibition technique than the most brilliantly designed architectural and display confection."

Simplicity of idea is their keynote to a successful show: "The section of the public who can remember facts and a reasoned argument is too small to consider when planning an exhibition addressed to very general audiences . . . If the cost is to be justified, 90 per cent of the visitors must leave with a general idea firmly implanted in their minds, preferably having retained one or two visual images, or slogans, (Continued on page 176)

it's the nation's largest **COPPER**
roof

Specially designed rubber-tired carts moved with lines and pulleys hold workmen on steep slope of main roof. John A. Johnson, Supt. of Building; Long & Thorshov, Inc., Architects; Carl Johnson, Contractor.

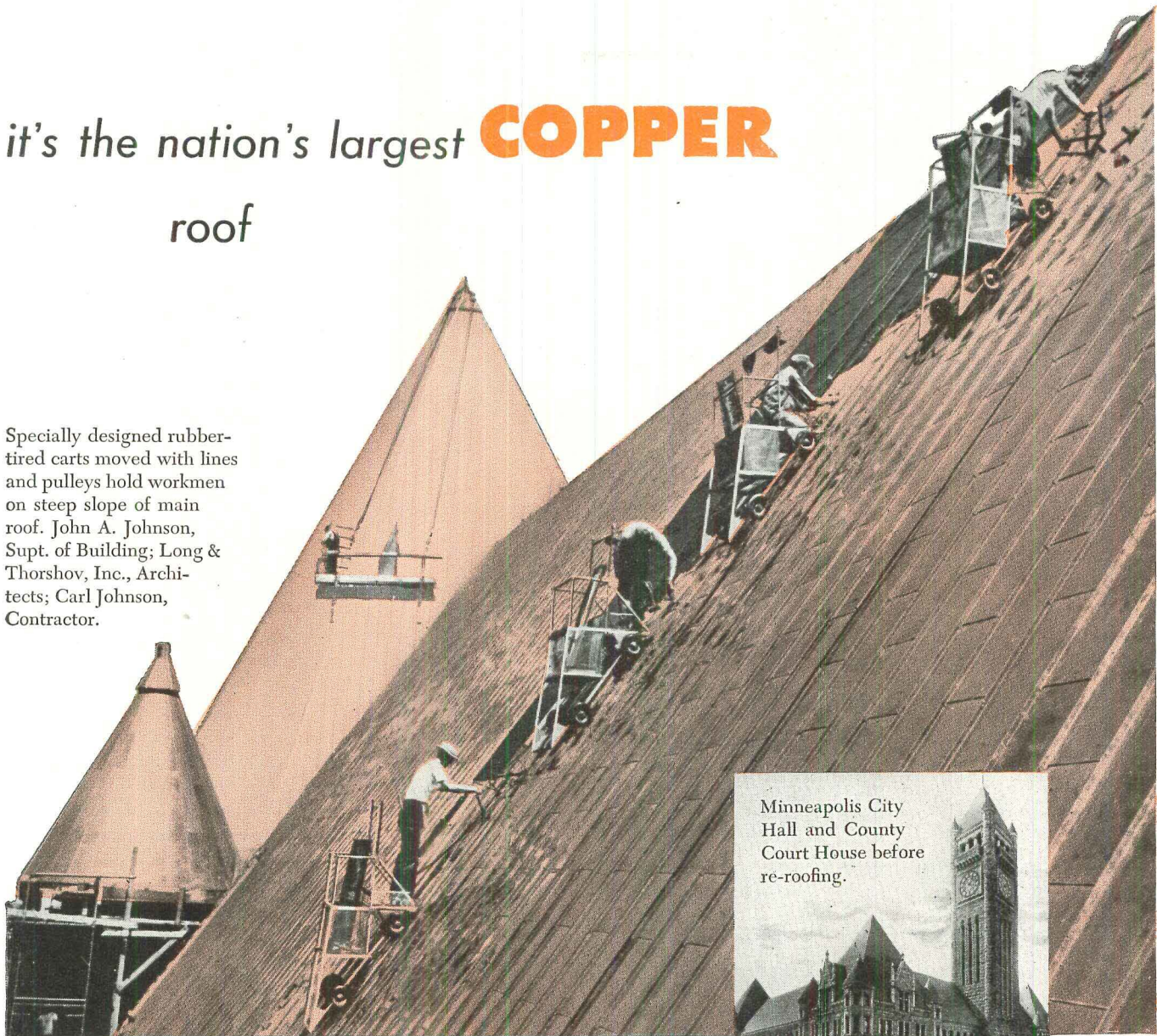

Minneapolis City Hall and County Court House before re-roofing.

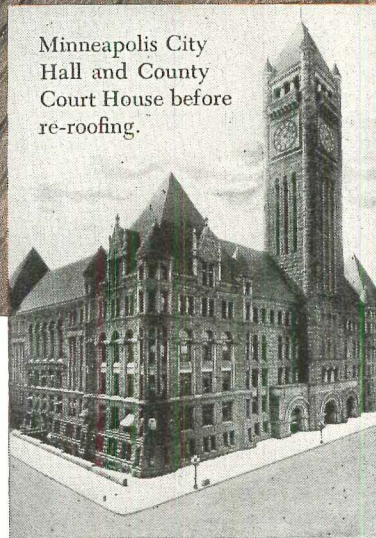

When the officials in charge of Minneapolis' block-square City Hall and County Court House were faced with replacing its vast roof, they decided that only a copper roof could economically match the durability of this monumental building.

This huge new roof — using 180,000 pounds of copper — is an outstanding example of the ideal combination of sound design, use of correct copper gages and tempers and intelligent workmanship that makes a copper roof unequalled for long life, low maintenance and ultimate economy.

ANACONDA 20-oz. cornice temper Sheet Copper was used throughout for the standing seam roofing; 24-oz. cold-rolled, lead-coated Copper for the gutters; and 32-oz. cornice temper Copper for a deep fascia at the junction of roof and side walls at cornice level. Full provision has been made throughout for expansion and contraction.

Anaconda Technical Department specialists were privileged to consult with the various officials and groups charged with the design and construction of this important roofing job. Their counsel is equally available to you in all problems involving sheet copper design and construction. The American Brass Company, Waterbury 20, Connecticut. In Canada: Anaconda American Brass Ltd., New Toronto, Ontario.

5005

you can build it better with—

ANACONDA[®]
COPPER

COLORFUL

Inexpensive Luxury!



Coronet
PLASTIC WALL TILE

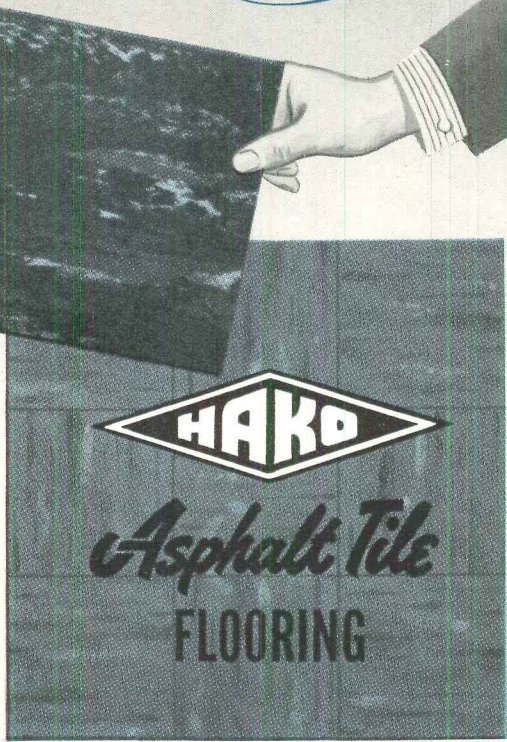

HAKO
Asphalt Tile
FLOORING

**for every
floor . . .
for every
tile wall**

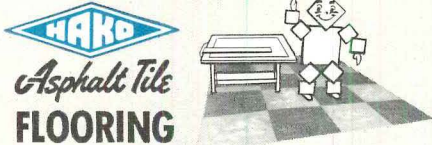

STYLE MATCHED WALLS AND FLOORS

Design this colorful inexpensive luxury into your clients plans whether it is a new project or a remodeling. It has a place in all homes, commercial and retail establishments, no matter what the price or style. Look at these advantages: negligible load bearing factor, lasts the life of the wall, 16 beautiful fade resistant colors in pastels and marbled tones, resistant to ordinary home acids, alkalis, and grease. It is waterproof, will not crack, chip or craze.

A leader in asphalt floor tiles with installations in leading commercial and retail establishments nation-wide. It is impervious to alkaline moisture present in the below or on-grade concrete slabs and gives long life with easy maintenance in heavy traffic areas. There are clear light pastels and rich warm colors in plain and marbled designs . . . shock absorbent resiliency. It is resistant to fire, cigarette burn, stain, indentation and moisture. Precision cut square edges save hours of labor on installation.



PARQUETRY

The newest floor tile where a hardwood floor effect is desired.

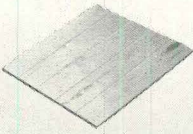

"Hachmeister Products of Merit"

HACHMEISTER, INC.
Dept. AF
Pittsburgh 13, Pa.

Yes, send me complete literature about colorful, inexpensive luxury for every floor, for every tile wall.

Firm _____
Address _____
City _____ Zone _____ State _____
By _____

Check here for complete literature on Parquetry, the flooring for every room.

HACHMEISTER-INC.
PITTSBURGH 13, PA.
Plants at Long Beach, California
and Pittsburgh, Pa.

REVIEWS

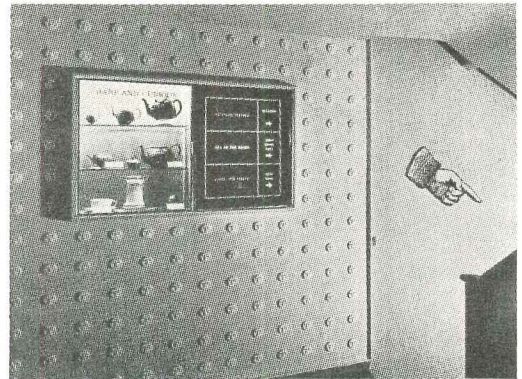

which sustain the general impression." Sequence is a major problem in large shows and some pointers are listed on how to preserve it:

1. At the entrance sufficient excitement to carry a sustained wave of attention;
2. A constant change of visual interest. Rooms in larger exhibitions should change in height and size and from dark to light;
3. Circulation must never be impeded — in booths over 1,000 sq. ft. this becomes a particular problem. Allow visitors to bypass or linger at particular parts. ("The designer should really work with his drawing board covered with ants.")

Everyday building rules of both design and construction are relaxed: "We have entered the realm when the designer may assume the cloak of the advertising man, the film director or the professional illusionist. The designer may wish to overwhelm the visitor making him lose his sense of self-importance so that, duly humbled, he can absorb facts which he would normally find unpalatable: alternatively, he may decide to build up the visitor's self-esteem . . . The appearance of the stand to the limited view of the visitor is the only really important aspect to consider."

Everyday building rules of both design and construction are relaxed: "We have entered the realm when the designer may assume the cloak of the advertising man, the film director or the professional illusionist. The designer may wish to overwhelm the visitor making him lose his sense of self-importance so that, duly humbled, he can absorb facts which he would normally find unpalatable: alternatively, he may decide to build up the visitor's self-esteem . . . The appearance of the stand to the limited view of the visitor is the only really important aspect to consider."

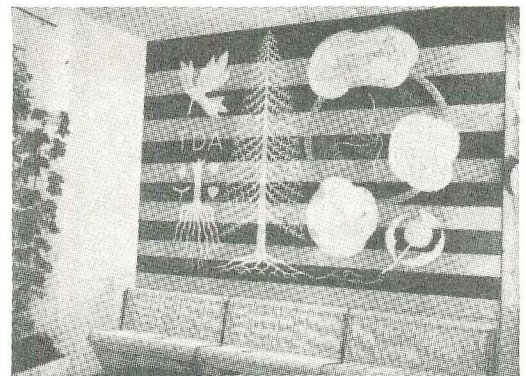

Construction methods are "almost a caricature of sound building methods. It is possible to fine down a ceiling to almost a wafer, and vertical supporting members can be extremely light and slender . . . Part of the adventure is the apparent lack of support, which can often be obtained by judiciously hanging the structure from the roof."

Practical chapters outline the place of lighting, sound, planting, scripts, models and display devices, as well as murals and typography, in creating the exhibit for maximum effect. Two of the excellent details which illustrate the book are shown on this page.—S.K.

(Continued on page 180)

NOW AT LAST!
**CLEAN,
UNCLUTTERED
ROOF-LINES**

PATENT
PENDING

WASCOLITE

Plexiglas

DOME SKYLIGHT UNITS

pre-fabricated, ready to drop in place!

- Simple to specify
- Strong, shatterproof, easy to clean
- Absolutely water-tight
- Easy to install

Good design brought to the roof-tops at last with WASCOLITES, the new sparkling, clear skylight units. Neat and attractive in appearance, WASCOLITES stay that way for they are shatterproof and practically self-cleaning. Their smooth surface is easily wiped clean with a damp cloth.

WASCOLITES flood interiors with unobstructed light. Inside nothing but the sky is visible. And WASCOLITES are completely pre-fabricated . . . installed in a matter of minutes simply by turning a few screws.

Send for our A.I.A. folder for the full story. And ask the name of our nearest WASCO representative. He has a WASCOLITE unit to show you.

WASCO FLASHING COMPANY · CAMBRIDGE · MASS.

CECO

An Invitation

CECO invites members of the Building Industry to write for help on construction problems. Send for any one or all of the bulletins listed below. Check those you want and mail coupon today.

R.S.V.P.

CECO STEEL PRODUCTS CORP.—Dept. AF-1
5601 W. 26TH ST., CHICAGO 50, ILL.

- Concrete Joist Construction
- Steel Windows and Doors
- Steel Joists
- Screens and Storm Windows

NAME _____
TYPE OF BUSINESS _____
FIRM _____
ADDRESS _____
CITY _____ ZONE _____ STATE _____



**CECO
STEEL**

In construction products **CECO ENGINEERING**

covers the construction field

**One source, one order fills
your metal building needs . . .**

With metal products for every building purpose, Ceko indeed covers the field. And whatever your building need, one order takes care of it all. Ceko can supply you with the finest in engineered steel products for monumental buildings, for institutional buildings, for commercial buildings. Ceko metal products also fit economically into the small home—cut fire hazards—increase building strength—reduce installation costs. For Ceko builds small with the same engineering precision they build big. Years of pioneering . . . years of on-the-job experience in the construction field have given Ceko engineers a sure grasp of all building problems. Ceko's plants, too, are strategically located to give fast coast-to-coast service. For detailed information, accept Ceko's invitation. Write for FREE Bulletins on Ceko Products today.



Ceko literature is full of installation tips and product data. It is FREE to all building men. Fill out coupon and mail today. Also see Ceko literature in Sweet's Architectural and Builders Files.

CECO STEEL PRODUCTS CORPORATION

General Offices: 5601 West 26th Street, Chicago 50, Illinois

Offices, warehouses and fabricating plants in principal cities

makes the big difference

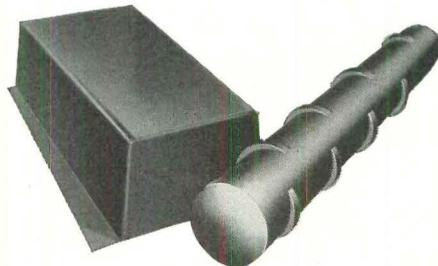

CONCRETE JOIST CONSTRUCTION

Building costs are cut with Concrete Joist Construction. Concrete is kept to a minimum for any span or live load. Removable Meyer Steelforms permit using the forms again and again. Above is pictured a Meyer Steelform and Reinforcing Bar.



STEEL WINDOWS

Full line—monumental, industrial and residential. Steel windows are economical. They cannot stick, warp or swell. They afford ample view, admit more daylight . . . are fire-resistant, provide means of escape in emergency.



STEEL JOISTS

Ceko Open-Web Steel Joists offer the most economical method of building. They assure fire and sound resistive structures. They're light, easy to install and self-centering. Ducts, wiring and piping can be concealed.

Partial List of Ceko Products

- METAL RESIDENCE CASEMENTS • INDUSTRIAL WINDOWS AND DOORS
- METAL FRAME SCREENS • ALUMINUM FRAME STORM WINDOWS •
- ALUMINUM COMBINATION STORM WINDOW AND SCREEN UNITS
- METAL LATH AND ACCESSORIES • STEELFORMS • REINFORCING BARS •
- STEEL JOISTS AND ROOF DECK • HIGHWAY PRODUCTS •
- CORRUGATED ROOFING • ATTIC AND ROOF VENTILATORS

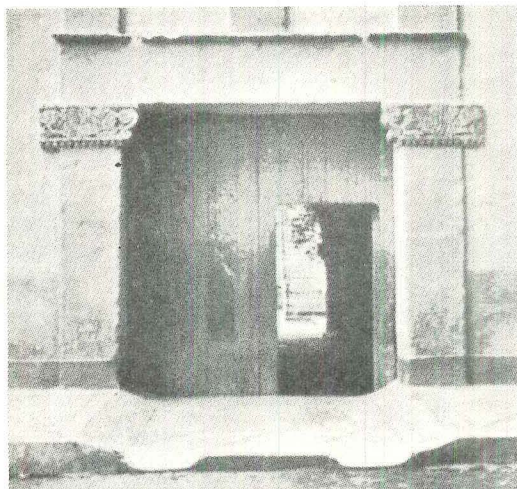

The symbol of Montezuma's Eagle Knights (each with a bearded European head in its beak) adorns this unsuspecting Spanish doorway—a parable of persistent native designs and techniques in Mexican art.

REVIEWS

MEXICO IN SCULPTURE, 1521-1821. By Elizabeth Wilder Weismann. Harvard University Press, Cambridge 38, Mass. 224 pp. 7½ x 10¼. Illus. \$7.50.

“A clash of cultures which had never known or dreamed of each other” produced the original and powerful Mexican sculpture on this page. Most histories have assumed that the Spanish conquerors overwhelmed the Indian artistic tradition as thoroughly as they did its military status and that art declined into a subservient ‘folk’ status. This new pictorial study shows that not only did native “habits of conception, design and technique” continue, but they vitally changed Spanish architecture to produce a type sometimes wondered at by historians but never hitherto understood.

Preconquest Mayan sculpture possessed many of the qualities most admired in stonework today: “The value of the material is never lost; form must be compact, folding in on itself in order not to break the surface of the mass or to impair the sense of bulk and weight.” The carvings are superbly decorative, characterized by a “uniformly spaced pattern covering the total surface.” Their firm dramatic forms express religious traditions that the native carvers had seen only through the medium of fluid Spanish baroque. Here, disciplined to only two levels of relief, the sculpture often surpasses its European models, creating new and admirable patterns.



The sculptured cross in Atzacolco (shown above) is one of the most successful examples of this fusion—all the forms are traditional European ones but they are assembled in a characteristically Indian manner. “The symbols of the Passion are woven into the texture of the Cross around the mask of Christ. It does not actually describe but symbolizes” the crucifix.

In the architecture of Mexican churches the more subtle imprint of the Indian tradition has been overlooked. From the very beginning native skill in stonework introduced itself to the new churches. Miss Weismann's photos reveal the freshness of their decoration which are able to enliven classic fronds and garlands with local fruits and animals. Later on, when the two cultures had been fused, the “strange encrusted flatness” which was basic in Indian design reshaped the architecture itself.

(Continued on page 184)

Get Better Storage WITH MENGEL WALL CLOSETS!

- Prefabricated Closets — Replace Costly Conventional Closet Construction!
- Sliding Doors Save Living Space — Float on Ball-Bearing Hangers!
- Interiors 100% Usable — Adjustable Shelves, Rods and Sliding Drawers!
- Separate Top Compartments — Ideal for Semi-Permanent Storage!
- Birch for Lovely Natural Finishes, or Prime-Coated for Finish Painting!

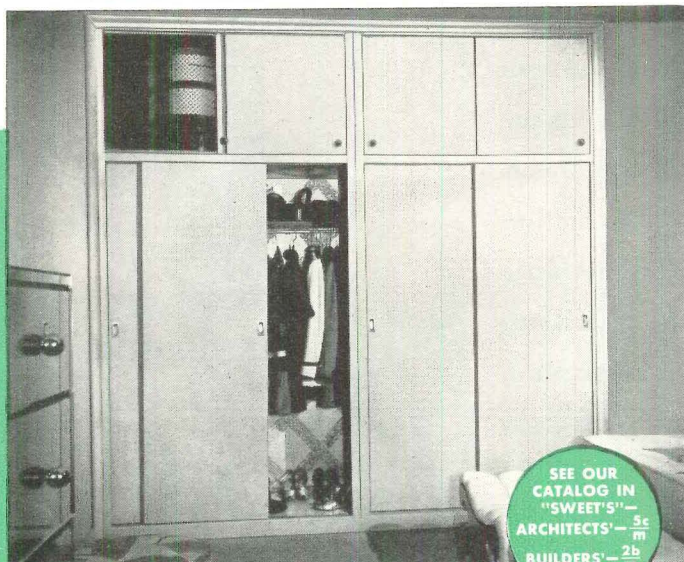

SEE OUR CATALOG IN
“SWEET’S” — 3c
ARCHITECTS’ — 3c
BUILDERS’ — 2b

Mengel Wood Wall Closets are complete “packaged” units, ready for quick installation. Their prefabricated design eliminates costly wood-stud closet construction—thus provides more storage for the *same* costs, or equal storage for *less* cost, than conventional closets!

In addition to space and money-saving advantages, Mengel Wall Closets add real *sales* features to a house by providing better storage and greater beauty than ordinary closets. Movable shelves, rods and sliding drawers (optional) can be quickly rearranged to meet changing needs. Easy-rolling sliding doors make any part of the interior readily accessible and provide a handsome flush-wall appearance!



Mengel Wall Closets are available in a variety of sizes and models. Shipped KD with all hardware included. Meet FHA requirements. If complete closets are not needed, use Mengel Closet-Fronts-with-Frames or Mengel Topflight Sliding Doors. *Mail the coupon for complete information!*

Cabinet Division—Dept. AF-12
THE MENGEL COMPANY
1122 Dumesnil St., Louisville 1, Ky.

Gentlemen: Please send me complete information about Mengel Wall Closets, Closet Fronts, and Topflight Doors.

Name _____
Firm _____
Street _____
City _____ State _____

NOW 12 good names

to know

when you want
Facing Tile
at its best

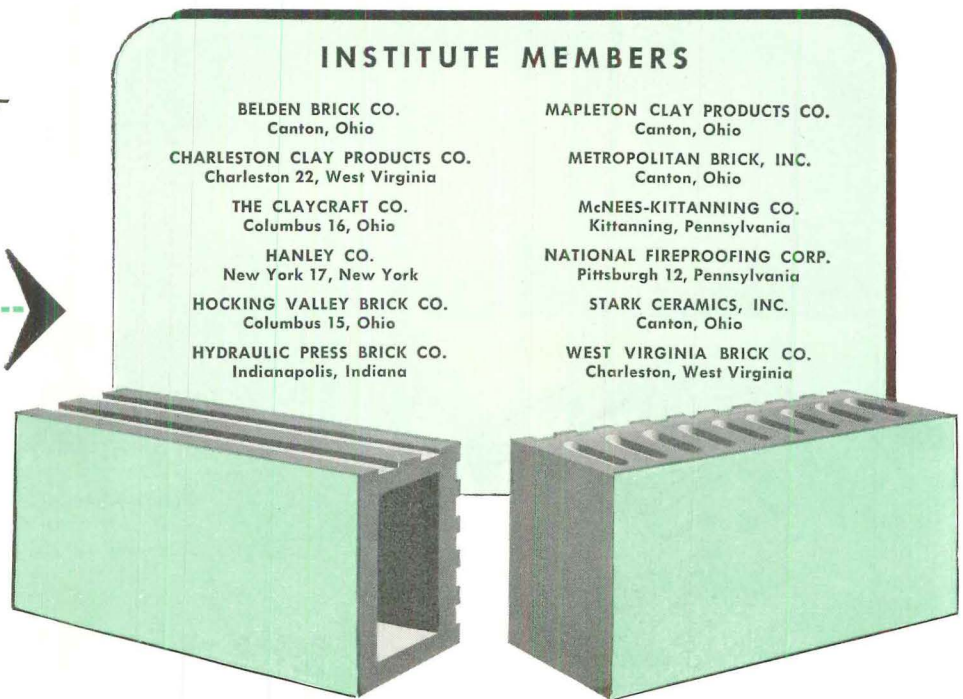

"Can I be sure the Structural Facing Tile I choose is a quality product?"

"Can I be sure it comes in dimensions most suitable for easy, economical use?"

There are other questions you could ask, but these two simple ones spring naturally to your mind when you're choosing Structural Clay Facing Tile—the "wall and finish in one."

They're more easily and satisfactorily answered, when you ask them of any one of the companies named above.

These companies are all members of the Facing Tile Institute. *And the aim of the Institute, and of the members who maintain it, is to furnish you with fine quality, easy-*

to-use Structural Facing Tile, glazed and unglazed.

The Institute, in fact, was formed for this purpose. Through the years, members have devoted continuous research toward improving quality, simplifying and standardizing shapes and sizes, and obtaining a full range of colors and finishes.

Each member of the Institute guarantees that any product manufactured by him will conform to the quality standards, tolerances and grading rules established and maintained by the Institute.

For more information about the "12 good names to know" and technical data about Facing Tile, write to the Institute, Desk AF-1, for the new catalog 51-C.

FACING TILE INSTITUTE

1520 18th Street, N. W., Washington 6, D. C.

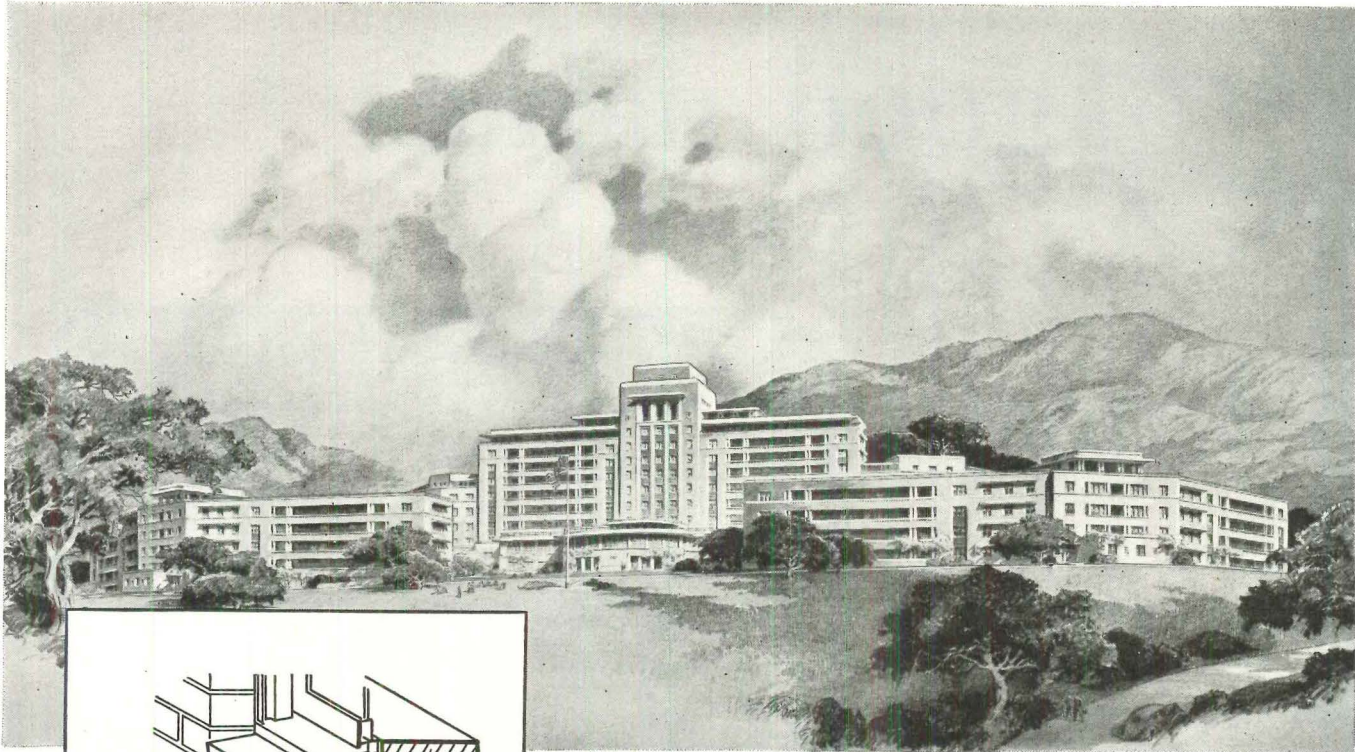

*Tripler General Hospital, U. S. Army Medical Dept., Hawaii
— Architects: York and Sawyer, New York City. 1½"
Alberene slip sills.*

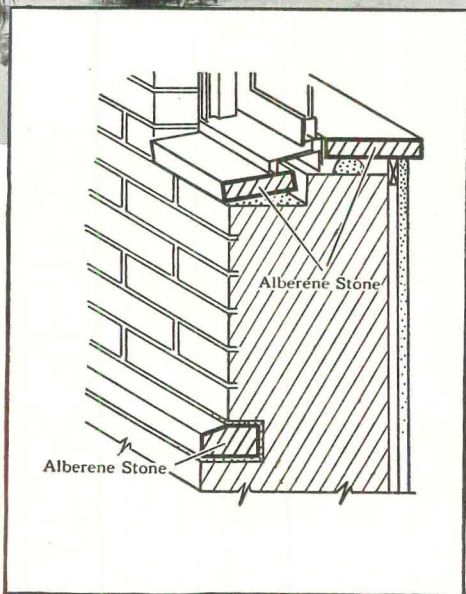

Detail showing 1½" thick slip sill with 1¼" stool and 2¼" belt course.

sills, stools, and trim
of **ALBERENE** stone are
DURABLE and ECONOMICAL

Regular Grade Alberene Stone is an ideal material for exterior trim because it can be cut into thin sections, permitting substantial economies. It offers freedom to the designer—by making possible greater reveal, to give just one example.

The stone has no cleavage planes, is dense, non-absorbent, and chemically-resistant. It is free of maintenance cost. Its color—silver gray in rubbed finish and a pleasing blue gray when honed—harmonizes well with almost any color scheme.

Where a darker color is desired, we suggest

Alberene Serpentine. It is a darker gray in rubbed finish, black when honed, and black with a slight greenish cast when polished.

The high chemical resistance of both stones, which has made them favorites for use in laboratory equipment, also makes them ideal for window stools in laboratory buildings.

Since there is a decided difference in price between Alberene *Regular Grade* and *Serpentine*, architects' specifications should be carefully worded so as to clearly call for the type desired. Ample supplies of both materials are available.

ALBERENE STONE CORPORATION

419 Fourth Avenue, New York 16, N. Y.

Branches in Principal Cities

GOOD FOR THE *Building*

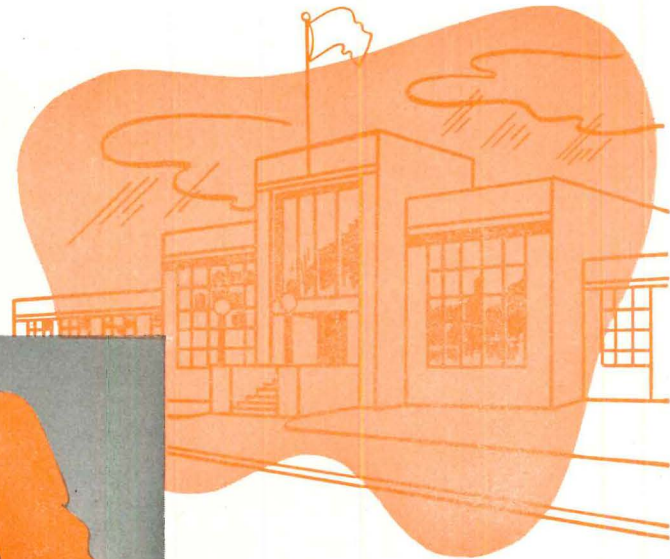
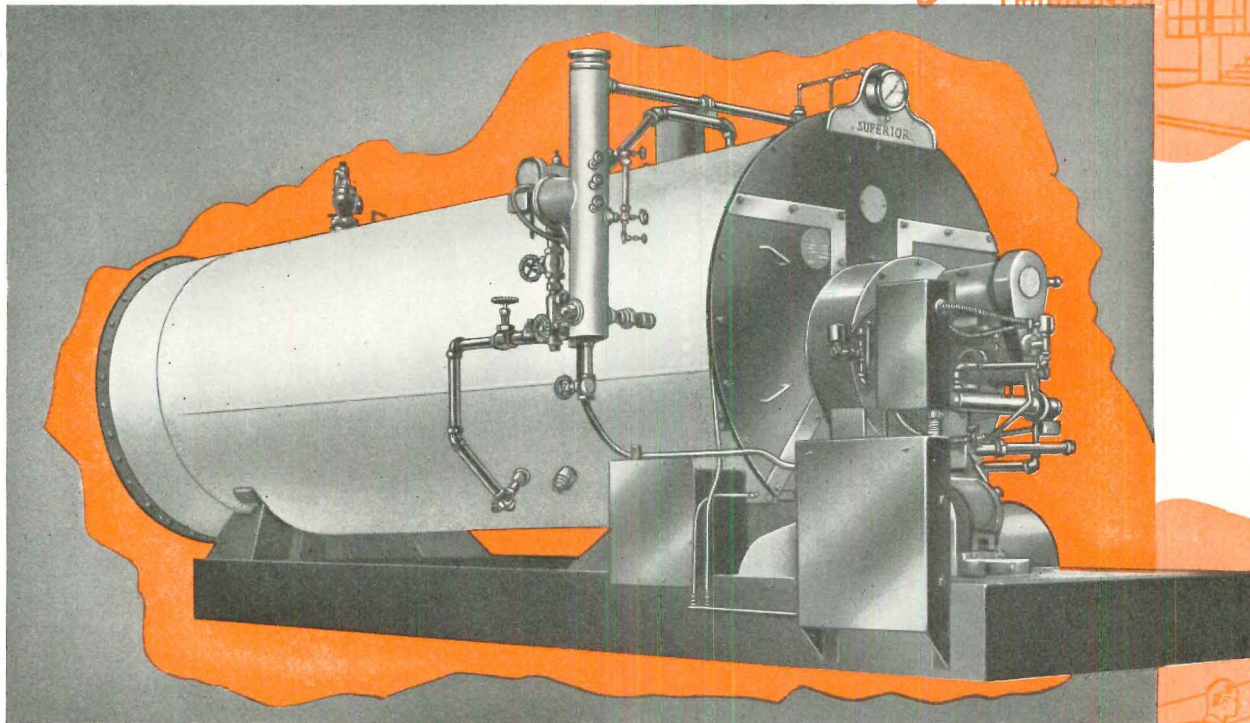

GOOD FOR THE *Budget*

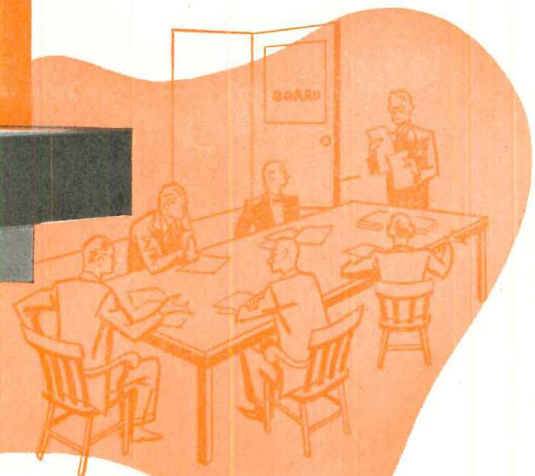

Superior Steam Generators are an ideal solution to the generation of heat and power. Shipped completely assembled after factory test, they are backed by the undivided responsibility of the maker. Installation is simple and inexpensive. No special foundation is required. Rugged and compact, they fit into small space.

Superior's built-in induced draft eliminates the need of an expensive chimney, and the possibility of forcing the products of combustion out into the boiler room.

Built for years of dependable low cost operation, Superior Steam Generators reduce maintenance to a minimum and earn their cost many times over through long-lived efficiency. They are guaranteed to generate maximum capacities at thermal efficiencies in excess of 80% and will burn the heaviest and cheapest grades of oil (or gas) fully automatically.

Clean, quiet, safe reliable operation, plus a saving of 20% or more over conventional boiler installations, make Superior Steam Generators the ideal steam plant.

A full range of sizes from 20 to 600 b.h.p. for pressures from 15 to 250 p.s.i. or in the hot water type, provides units of proper capacity for every plant.

For complete details, write for Catalog 312.



Superior Combustion Industries, inc.

Factory: Emmaus, Pa.

Executive Offices: Times Building, Times Square, New York 18, N. Y.

NOW!...

PITTSBURGH
INTERLOCK
PLASTIC WALL TILE

with the newest
BEVEL EDGE

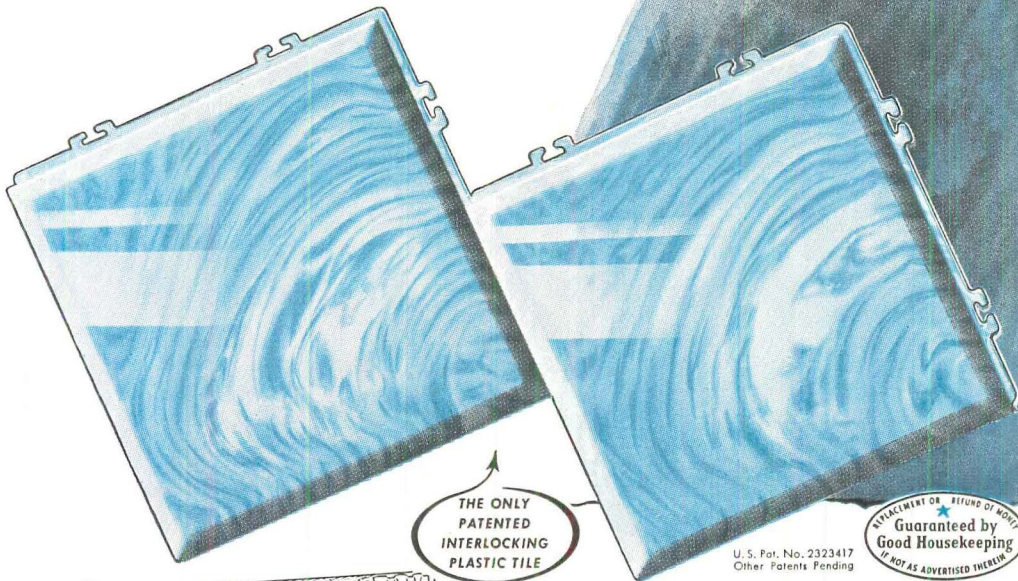

THE ONLY
PATENTED
INTERLOCKING
PLASTIC TILE

U. S. Pat. No. 2,323,417
Other Patents Pending

REPLACEMENT OR REFUND OF MONEY
Guaranteed by
Good Housekeeping
IF NOT AS ADVERTISED THEREIN

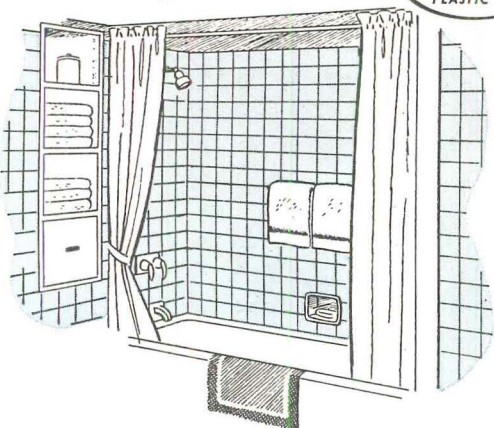

- Fits all building requirements
- Newest 1951 decorators' colors
- Will not chip, crack or craze
- Quick, easy installation
- Requires less mastic
- No time-wasting grouting

From the smallest tile installation to the largest of housing projects, "Interlock" fits perfectly in low-cost budgets of builders, contractors and architects. And this new "Interlock" styling will give any wall the aristocratic tile beauty demanded by decorators from coast to coast.

Patented interlocking feature permits quicker installation and permanency of the finished job. Made of Styron, "Interlock" comes in hundreds of different color combinations . . . all molded through and through!

As the leader in the plastic wall tile market, "Interlock" has proven its worth in new home building and in remodernization work!

Tile specialists on our staff are always ready to help members of the trade in their planning. For instructions, samples and assistance in filling your tile requirements, write us today!

Accepted by the U.S.
Dept. of Commerce,
Bureau of Standards



MADE OF
STYRON

JONES & BROWN, Inc.
National Distributors
PITTSBURGH, PA.

JONES & BROWN, INC., Dept. A J
439 Sixth Ave., Pittsburgh 19, Pa.

Please let me have more information
about Pittsburgh "Interlock" Plastic Wall Tile.

Contractor Builder Dealer

Name.....

Street.....

City.....State.....

REVIEWS

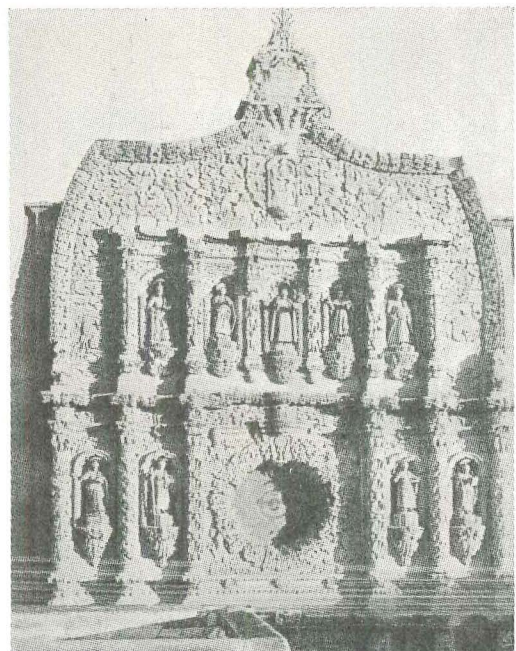

It has long been recognized that Mexican churches outdid their Spanish originals in the uninhibited splendor of their gold interiors. Their gradual development of an overall spreading pattern has been regarded as simply an extension of the Spanish baroque instead of a resurgence of the Indian sense of total design. The Cathedral at Zacatecas built between 1718 and 1752 shows this combination most strikingly. Over its undoubtedly Spanish contours the native sculpture—"bold, exaggerated, irrational". . . ties the varied elements into a forceful unified facade (above).—S.K.

HISTORY OF MODERN PAINTING in three volumes. I—Impressionism, \$12.50; II—Fauvism and Expressionism, \$12.50; III—From Cubism to Surrealism, \$15.

ITALIAN PAINTING—The Creators of the Renaissance from the Middle Ages to Leonardo da Vinci. \$15. All illustrations in color. 10 x 13. Albert Skira, 206 E. 20th St., New York, N. Y.

When something superb is accomplished in any one field of art, it is bound to have a bearing on the others. The four volumes of art history which Albert Skira is now publishing in America forms—without fear of contradiction—one of the most beautiful collections of color reproductions ever presented. Such a fine gallery of paintings (some widely acclaimed, many little-known) is a delight and challenge for anyone interested or involved in the visual arts.

The triad on modern painting brings within a portable span the great variety achieved in this too-often oversimplified field. The extraordinary brilliance of *Italian Painting*, which stresses seldom-seen murals and frescoes, cannot help but be a refresher course in the possibilities of that building element, the wall surface. The craftsmanship of these books (for which the price is amazingly low) deserves a salute from fine craftsmen everywhere.—S.K.

(Continued on page 188)

Another builder gets on the **BANDWAGON**

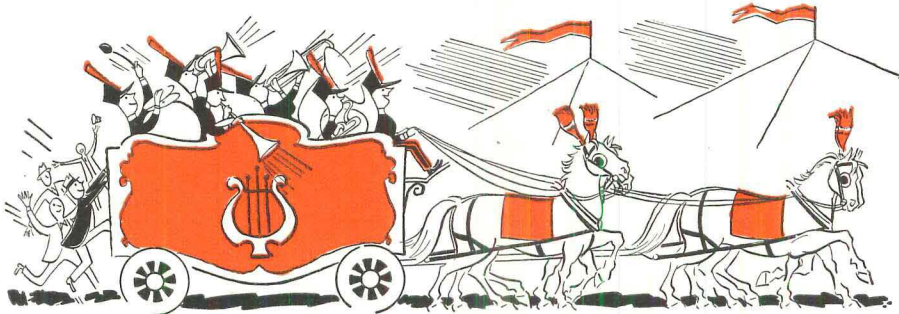

Builder
**William
A. Zeh,**
*of Los Angeles,
equips his homes
with
Electric Ranges
exclusively*



The all-electric kitchen of the Zeh home features not only an electric refrigerator, ventilator, food waste disposer and fully automatic laundry, but the kind of range that's truly automatic, really modern. Of course . . . it's **ELECTRIC!**

This Zeh home in Los Angeles has the kind of architectural lines that makes home seekers become home buyers. Flood lighting and weather-proof convenience outlets make electric convenience available outdoors, too!

"It takes more than looks to sell a house and keep it sold," says Mr. Zeh whose homes in Los Angeles, California, have made a national reputation. "No builder nowadays would think of installing anything but automatic heat and automatic electric refrigerators in his new houses. And just as people take those things for granted, they're looking for automatic electric cooking equipment."

Are you giving home buyers what they want in the houses you build for them—automatic modern *Electric Ranges*?

EQUIP
YOUR HOUSES WITH
ELECTRIC
RANGES



ELECTRIC RANGE SECTION
National Electrical Manufacturers Association
155 East 44th Street, New York 17, N. Y.

ADMIRAL • COOLERATOR • CROSLY • DEEPFREEZE
FRIGIDAIRE • GENERAL ELECTRIC • GIBSON • HOTPOINT
KELVINATOR • LEDO • MONARCH • NORGE • PHILCO
UNIVERSAL • WESTINGHOUSE



Getty operators

make every inch of window area available for ventilation

	<p>Operator 4715 for wood casements is an inexpensive worm and gear angle-drive operator that functions through screens on casements carrying butt or extension hinges. It is precision-built, easily installed (2 measurements, 6 screws), lubricated for life.</p>
<p>Operator 4703W for wood casements is a precision-built instrument with the <u>exclusive</u> internal gear. It operates through screens, on all <u>wooden</u> casements equipped with butt or extension hinges.</p>	

At the touch of a finger, Getty-operated casements make every inch of window area available for fresh air, or lock securely at any opening desired. Getty operators are ready to go to work in any weather, in any season—and render long, troublefree service.

That's why architects, builders, contractors, casement manufacturers, hardware wholesalers and dealers, and building material dealers specify, use and carry the Getty line. That's why *Getty operators are found on more casement windows than all other operators combined.*

Write for our descriptive brochure F. It contains complete information on our three operators (internal gear, external gear, horizontal drive) and our specialty hardware for every type of *wood* and *metal* casement.



& Co., Inc.

3348 NORTH 10th STREET

PHILADELPHIA 40, PA.

ANNOUNCING THE G-E RESIDENTIAL WIRING SERVICE

Designed to help you plan for G-E Remote-Control Wiring

FREE FOLDER DESCRIBES THIS NEW SERVICE

- Tells how to take advantage of the General Electric Residential Wiring Service.
- Explains how G-E wiring specialists will custom-plan a remote-control wiring layout to your specifications.
- Describes how you can get complete installation details for your electrical contractors.

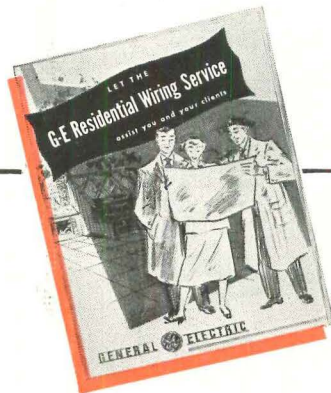

Interest in G-E remote-control wiring is increasing every day. Home planners see in this new wiring system features and advantages that they want and need.

Because G-E remote-control wiring can contribute so much to comfort . . . because it makes electricity a more useful servant in any type of home . . . you'll want to offer the advantages of this new type of wiring system to your clients.

A SERVICE TO ARCHITECTS AND ENGINEERS

To assist you in planning a remote-control wiring system, the General Electric Construction Materials Department has established the "G-E Residential Wiring Service." Through this free service, architects and engineers can obtain complete information and assistance on remote-control wiring for any residential building. You'll find the service a source of useful ideas . . . helpful in making electricity do a better job in the residences you design.

Write on your letterhead for this helpful "G-E Residential Wiring Service" folder. Address: Section D51-114, Construction Materials Department, General Electric Company, Bridgeport 2, Connecticut.

You can put your confidence in—

GENERAL  ELECTRIC



The West does nothing halfway — Architecture West illustrates how wildly (above) and how well (right) she has interpreted building forms in the past hundred years.



REVIEWS

ARCHITECTURE WEST, a 16 mm. film by Erven Jourdan. Script by Esther McCoy. Allen-Moore Productions, Inc., 213 West Seventh St., Los Angeles, Calif. 20 min. running time. Print, \$150. Daily Rental, \$10.

THE ARCHITECTURE OF THE OLD SOUTHWEST—Indian, Spanish, American. By Trent E. Sanford. W. W. Norton & Co., Inc., 101 Fifth Ave., New York, N. Y. 312 pp. Illus. 6¼ x 9¼. \$5.

The centenary of U. S. settlement of the West Coast has not been allowed to pass unnoticed. Books, exhibits and pageants have recorded and dramatized the hundred-year change which brought this rich and varied wilderness to its present state—still rich if rather more dubiously varied.

Architecture West takes a quick look at the outstanding examples of building in Washington, Oregon and California from the early camp shelter and farm to the best of the sleek open houses of the present—two extremes where straightforward design meet. Also (as indicated in the gingerbread gem of a house above) it glances at the overwrought specimens of some intermediate builders. Leading figures in western architecture are glimpsed both in person and in their works—the Greene Brothers, Maybeck, Schindler, Neutra, Yeon, Belluschi and Wurdeman & Beckett. (Frank Lloyd Wright's work in California and elsewhere was the subject of a film produced and released by the same group—see *Reviews*, September '48). Jourdan's color photography is a treat to the eye.

Architecture of the Old Southwest is a bulky, chatty literary amble which follows a course through Texas, New Mexico, Arizona and California. This path is more or less that of the Indian tribes and that of the later exploring Spaniards. The author provides scraps of history and description of the buildings and struggles of Indian, Spanish and early American settlers.

ARCHITECTURE—Five Thousand Years of Building. By Joseph Watterson. W. W. Norton & Co., Inc., 101 Fifth Ave., New York, N. Y. 399 pp. 6¼ x 9½. Illus. \$6.

This book has so many good points that it would be a great satisfaction to be able to give it an unqualified *hurray*. The old-as-the-hills subject matter is written up with verve and freshness. Focus is kept on the truly creative elements of each building civilization. Archeology and social
(Continued on page 192)

ARCHITECTS SURE MAKE A HIT—

WHEN THEY SPECIFY

AMWELD

STEEL DOORS

AND FRAMES

AND SLIDING

CLOSET DOOR UNITS

All over the country, architects are receiving the praises of homemakers on the attractiveness of AMWELD Steel Doors & Frames and Sliding Closet Door Units. Architects also know that they cut building costs, blend with all types of architecture, require less installation time, and are competitive in price with other types of both wood and steel products. Send for new 12-page catalog.

K-D UNITS, TOO!

Sliding Closet Door Units are also available in packaged, knocked-down form, complete with header, jambs, track and hardware. Suitable for new construction and particularly adaptable for remodeling.



See us at the
NATIONAL HOME BUILDER SHOW
Stevens Hotel • Chicago
JANUARY 21 TO 25
BOOTH Nos. 186 - 187

BUILDING PRODUCTS DIVISION
THE AMERICAN WELDING & MANUFACTURING CO.
330 DIETZ ROAD • • • WARREN, OHIO



GEORGIA



FLORIDA

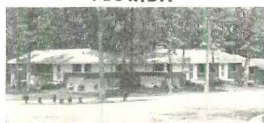

NORTH CAROLINA



MICHIGAN

Ruberoid

ROOF TOPS JOHNSON'S WAX TOWER

In this brilliantly conceived cantilevered structure "form follows function", as Frank Lloyd Wright once expressed his philosophy. Traditional elements have been retained only where their structural expressions are completely logical.

Because Ruberoid Built-Up Roofs are so logical, a Ruberoid roof was chosen for this outstanding building. A 4-ply coal tar pitch, felt and gravel roof was applied, part over cork, part over foam glass insulation.

Ruberoid specifications provide a functional, time-tested, simple solution to every roofing problem. If you don't have a new edition of Ruberoid's Roof Specification Book, a note on your letterhead will bring your free copy promptly.

S. C. Johnson & Son, Inc., Research and Development Tower, Racine, Wis.
Architect: Frank Lloyd Wright
Roofing Contractor: Badger Roofing & Siding Co.

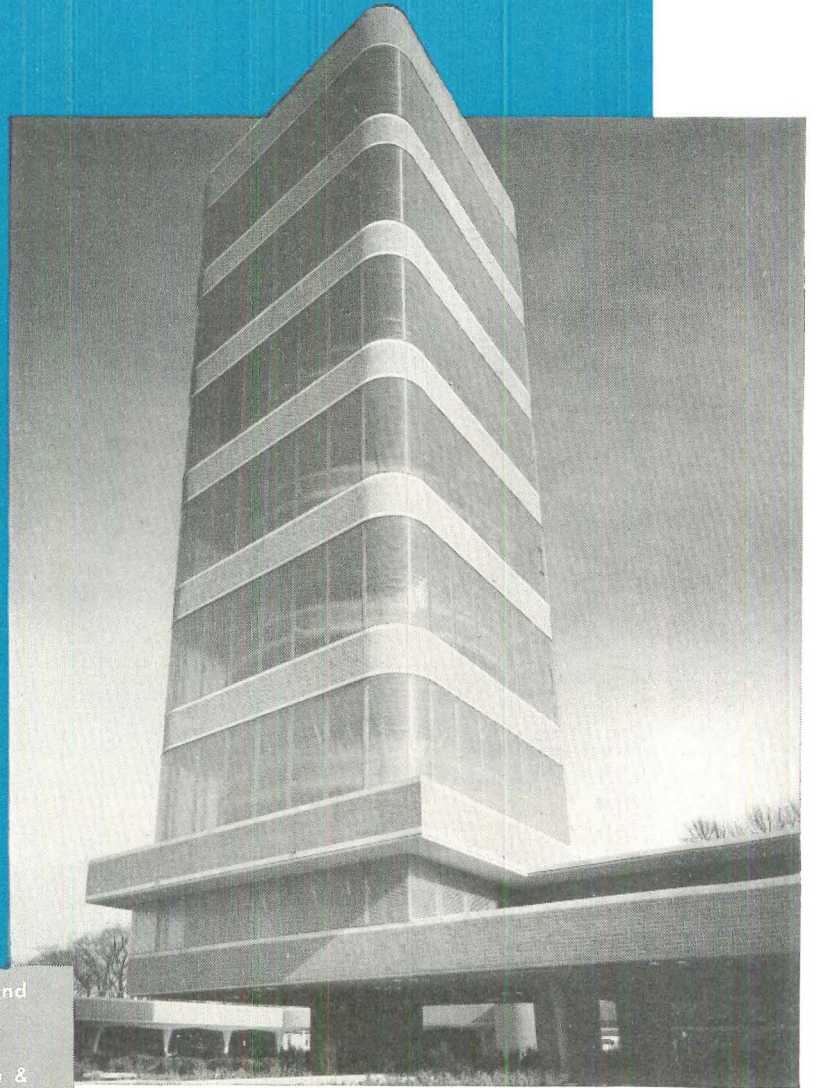

EZRA STOLLER © PICTOR

THE RIGHT ROOF FOR ANY JOB — FROM ONE SOURCE!

Ruberoid makes every type of built-up roof—Smooth Surfaced Asbestos, Coal Tar Pitch with gravel or slag surfacing, and smooth or gravel-and-slag surfaced Asphalt . . . in specifications to meet any need. Ruberoid Approved Roofers are not prejudiced in favor of any one type. You are assured of centralized responsibility, smoother operation, uniform quality with Ruberoid built-up roofings.

Sales Offices: Baltimore, Md. • Bound Brook, N.J. • Chicago, Ill. • Dallas, Tex. • Erie, Pa. • Millis, Mass. • Minneapolis, Minn. • Mobile, Ala.

The **RUBEROID** Co.

built-up roofings

500 FIFTH AVENUE, NEW YORK 18, N. Y.

MORE YEARS
FOR YOUR DOLLAR WITH
RUBEROID
BUILDING MATERIALS



Control Room: Radio Station WFDR, New York, N. Y.
Architect: Robin and Vogel, New York, N. Y.
Engineer: Fred L. Moesel Associates, New York, N. Y.
Mechanical Contractor: The J. M. Fink Co., New York, N. Y.

Twice beautiful to the engineer's eye...

kno-draft adjustable air diffusers

Beautiful to look at, of course...with an unobtrusive simplicity that is as much at ease amid the crystal chandeliers of a ballroom as in the stark severity of a broadcasting studio.

But the engineering eye sees also the functional beauty of Kno-Draft *Adjustable* Air Diffusers . . . the uncomplicated cleverness of engineering and design that assures an even distribution of air *without draft*.

Kno-Draft Air Diffusers are adjustable *after* installation. Both the volume of air and its direction can

be screw-driver controlled to balance temperature and distribution *exactly as required* throughout the entire conditioned area.

Still a third "beauty" of Kno-Draft *Adjustable* Air Diffusers is the complete satisfaction they give on the job. Types and sizes to meet every need.

KNO-DRAFT DATA BOOK: Complete specifications, engineering and installation data on Kno-Draft *Adjustable* Air Diffusers. To get your copy, simply fill in and mail the coupon. No obligation, of course.



TRADE MARK "KNO-DRAFT" REG. U. S. PAT. OFF.

W. B. CONNOR ENGINEERING CORP.
 Danbury, Connecticut
Air Diffusion • Air Purification • Air Recovery
 In Canada: Douglas Engineering Co., Ltd.,
 190 Murray Street, Montreal 3, P. Q.

W. B. CONNOR ENGINEERING CORP.
 Dept. D-11, Danbury, Connecticut

Please send me, without obligation, my copy of the Kno-Draft Air Diffuser Data Book.

Name

Position

Company

Street

City.....Zone.....State.....

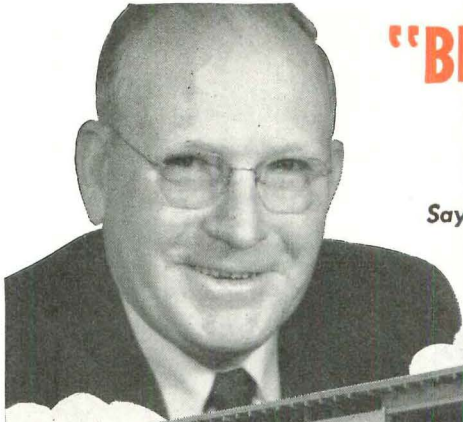

"BILDRITE* SHEATHING Saved Us \$200 on this job!"

Says E.R. Daleen, Purchasing Agent & Sec., Sauers Construction Co.



"Recently we were informed that 4 ft. Bildrite Sheathing had become the first insulating sheathing to meet the rigid requirements of FHA without use of corner bracing. We were at that time erecting Rose Vista Apartments in St. Paul, Minnesota, a \$1,500,000 project, using 2x8 ft. insulating sheathing. We immediately changed to 4x8 ft. Bildrite

Sheathing and realized a saving of \$80—\$100 per apartment building. Bildrite in the larger size cut both our labor and material costs and we also gained the greater bracing strength inherent in the 4x8 ft. sheet.

Insulating Sheathing has been used almost entirely on the 54 apartments erected during 1950 by the Sauers Construction Company in the Greater Minneapolis-St. Paul metropolitan areas. We prefer insulating sheathing because our cost studies prove that it costs \$75—\$100 less than wood sheathing on the average building. Frankly, we just can't afford to use conventional wood sheathing.

Simple addition shows that we can save up to \$200 per average building when we specify Bildrite Sheathing exclusively. Eliminating corner bracing and the lower cost of applying insulating sheathing is a worthwhile contribution that saves money during a critical period for the building industry. While it's important to us that Bildrite reduces costs, we also know that it means better wall construction. We've used Bildrite for many years and its strength, moisture resistance and over-all high quality make it definitely superior."

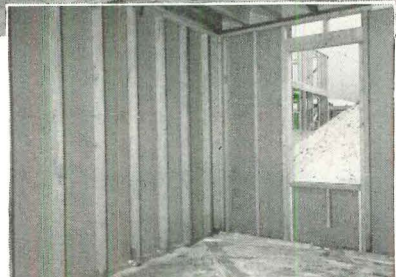

NO CORNER BRACING saved about \$100 in time and materials. BILDRITE—the first insulating sheathing to meet F.H.A. requirements without using additional corner bracing.



LOWER APPLIED COSTS of Bildrite saved another \$100. Bildrite handles easily, leaves no waste, and goes up in about half the time of wood sheathing. In addition, Bildrite offers extra resistance to moisture and extra insulating value.

INSULITE DIVISION

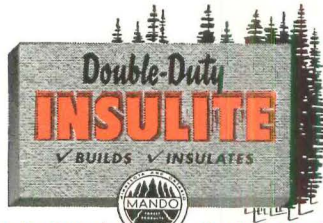

Made of Hardy Northern Wood

SPECIFY BILDRITE for better construction at lower cost.

**MINNESOTA AND ONTARIO PAPER COMPANY
MINNEAPOLIS 2, MINNESOTA**

1-51

* Reg. T.M.U.S. Pat. Off.
Refer to Sweet's File Architectural Section $\frac{10a}{1n}$.

Only

IN-SINK-ERATOR

among all Food Waste Disposers offers all these vital product advantages!

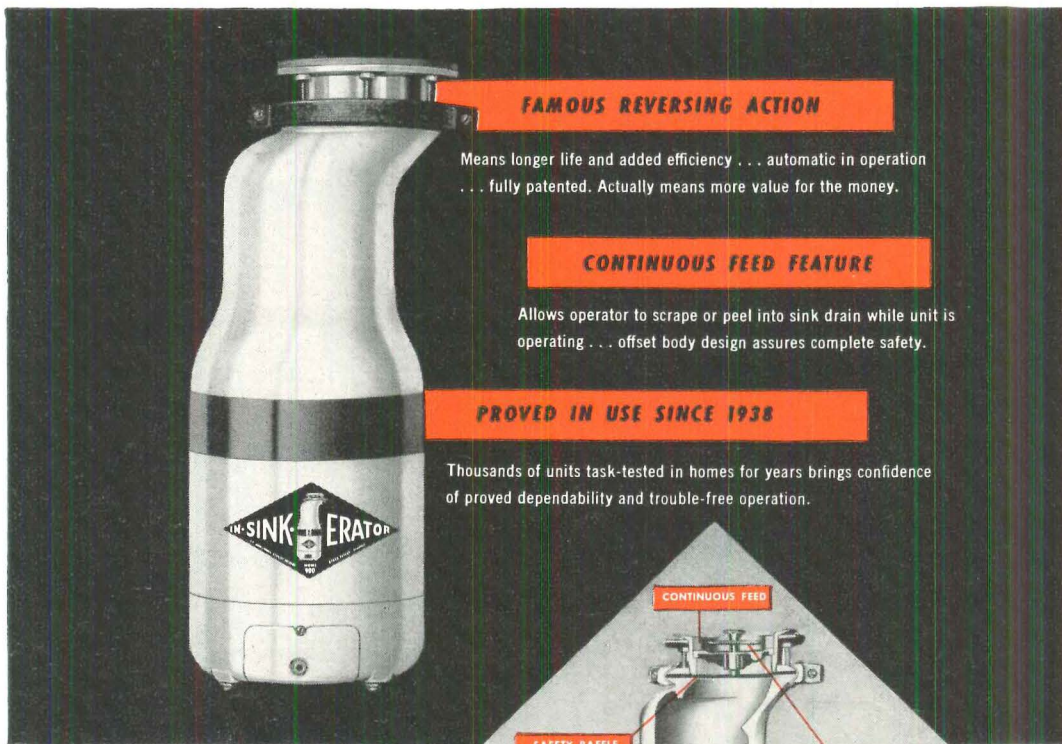

FAMOUS REVERSING ACTION

Means longer life and added efficiency . . . automatic in operation . . . fully patented. Actually means more value for the money.

CONTINUOUS FEED FEATURE

Allows operator to scrape or peel into sink drain while unit is operating . . . offset body design assures complete safety.

PROVED IN USE SINCE 1938

Thousands of units task-tested in homes for years brings confidence of proved dependability and trouble-free operation.

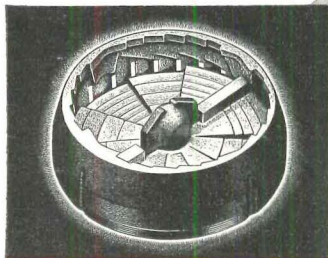

SECRET OF SUPERIORITY... this rugged rotary shredder is the only moving part . . . automatically alternates direction of rotation each time disposer is used . . . doubles life of shredding element, backs-away from jammed conditions and produces vigorous two-way self-cleaning.

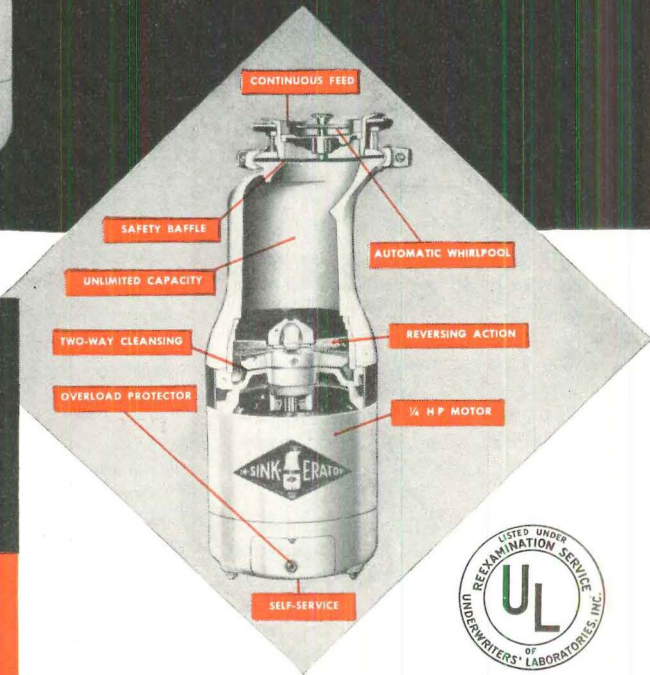

CONTINUOUS FEED

SAFETY BAFFLE

UNLIMITED CAPACITY

TWO-WAY CLEANSING

OVERLOAD PROTECTOR

AUTOMATIC WHIRLPOOL

REVERSING ACTION

1/4 H.P. MOTOR

SELF-SERVICE



EASY TO INSTALL

Simplicity of design permits easy, economical installation. No special tools or training required.

EASY TO SERVICE

Built-in features overcome minor operational difficulties and minimize need for outside service.

ONLY IN-SINK-ERATOR offers all these vital product advantages

ONLY IN-SINK-ERATOR was conceived and engineered by an Architect to meet the exacting requirements of the building profession.

SEE SWEET'S—6a/IN Builders, 24a/IN Architectural—or write for builder's data and prices

IN-SINK-ERATOR MANUFACTURING COMPANY

1213 FOURTEENTH STREET, RACINE, WISCONSIN

World's Oldest and Largest Exclusive Manufacturer of Food Waste Disposers

REVIEWS

history are kept in auxiliary roles—just enough to provide an intelligible background.

One might wish, however, that a brand-new “popular history of the most universal of the arts” might take a broader view than this well-worn ziggurat-to-temple-to-cathedral-to-skyscraper. Oriental influence on homes and landscaping, for example, should certainly be included. Watter-son’s explanation—it is “limited to architecture of those portions of the Mediterranean area, of western Europe and of North America which have had the most to do with the architecture that is our architecture today”—is only begging the question.

His greatest contribution as an architectural writer is a real enthusiasm for all brands of building. This helps him to appreciate concep-tions and methods of vastly varying minds and helps him (almost) to overcome that perennial barrier between “new” and “old.”

There is one great drawback to universal en-thusiasm—it tends to wear itself out. The sym-pathetic glow that the author enkindles with his warm descriptions of the Parthenon or a Frank Lloyd Wright house begins to flicker when one comes across such sentences as these: “Delano and Aldrich’s exquisitely studied Georgian houses are as fine architecture as has ever been done;” or “Grand Central Station (in New York) has one of the finest interiors of any age.”

However, for a single-volume introduction to architecture, here’s one that is clear, informed—and affectionate.—S.K.

BOOKS RECEIVED

A CRITICAL REVIEW OF LE CORBUSIER.

By P. M. Bardi. Museu de Arte de Sao Paulo, rua 7 de Abril, no. 216, Sao Paulo, Brazil. 6½ x 9½. 71 pp. Text in Portugese and English.

THE ENGLISH CATHEDRALS.

By Herbert Fel-ton & John Harvey. B. T. Barsford Ltd., 122 E. 55th St., New York 22, N. Y. 99 pp. Illus. 6 x 9. \$4.

PORTRAIT OF LINCOLN CATHEDRAL.

By G. H. Cook. Chanticleer Press, 41 E. 50th St., New York 22, N. Y. 65 pp. 9 x 11½. Illus. \$3.50.

PARLIAMENT HOUSE.

By Maurice Hastings. The Architectural Press, 13 Queen Anne’s Gate SW1, London, England. 200 pp. Illus. 5¾ x 8¼. 12 s. 6d.

PLANT LAYOUT AND MATERIALS HANDLING.

By James M. Apple. The Ronald Press Co., 15 E. 26th St., New York, N. Y. 367 pp. Illus. 6 x 9½. \$5.

SCENERY DESIGN FOR THE AMATEUR STAGE.

By Willard J. Friederich and John H. Fraser. Mac-millan Co. 60 Fifth Ave., New York 11, N. Y. 262 pp. Illus. 5¾ x 8¾. \$5.

A STUDY IN COMMUNITY SERVICE

(Libraries & Museums). Future Springfield Inc. 86 Hillman St., Springfield, Mass. 110 pp. 8½ x 10½. mimeo. \$1.25.

5 PEELLE MOTORIZED FREIGHT ELEVATOR DOORS

INSTALLED IN THIS MODERN PHARMACEUTICAL PLANT

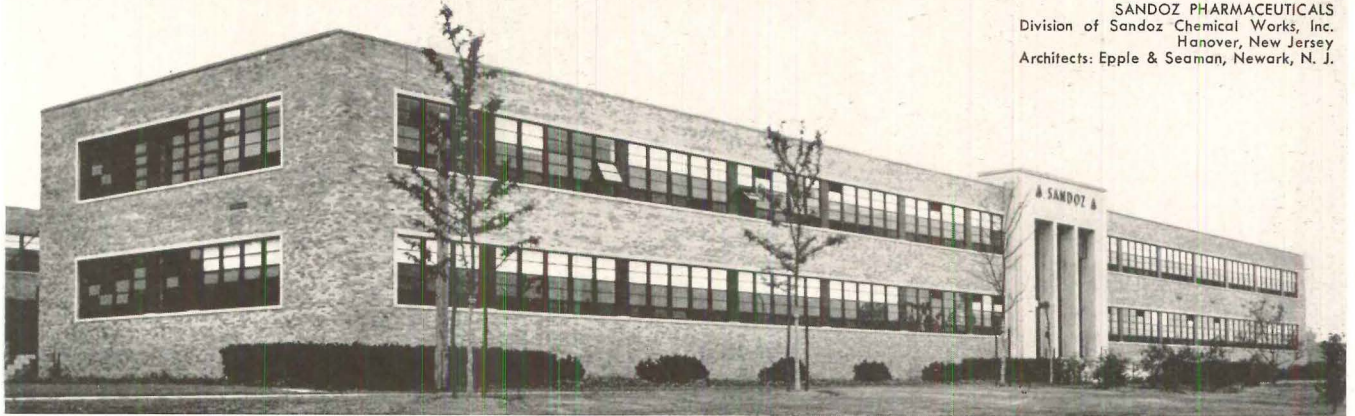

SANDOZ PHARMACEUTICALS
Division of Sandoz Chemical Works, Inc.
Hanover, New Jersey
Architects: Epple & Seaman, Newark, N. J.

because

they handle peak loads
with maximum efficiency
and minimum maintenance

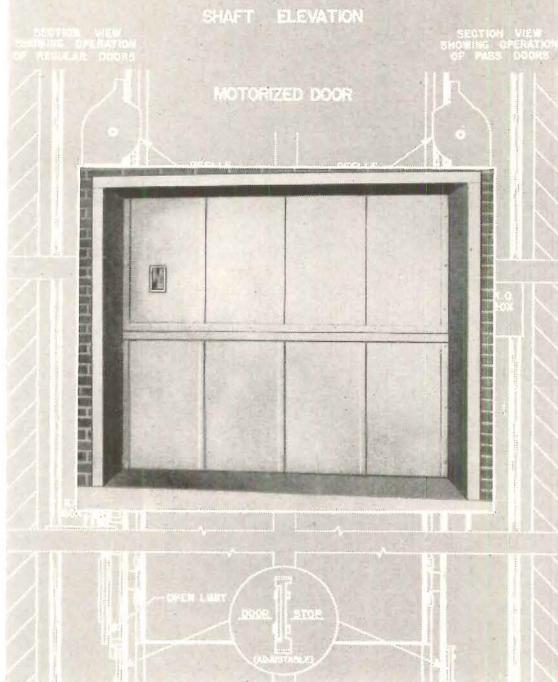

Peelle Counterbalanced Motorized Doors increase the carrying capacity of freight elevators as much as 20%. When peak load demands would tax the physical capacity of a manual operator, Peelle Motorized Doors and Peelle Vertical Sliding Car Gates open and close in one fourth the time of manually operated doors. This eliminates costly bottlenecks in busy plants, yet the cost of motorizing is but a small percentage of the total investment.

It is no mere chance that Peelle Motorized Freight Doors are being installed in so many modern plants. The Peelle Company has pioneered motorized doors for many years and has originated many major improvements which add to the safety and efficient operation of these doors.

Peelle Motorized Freight Elevator Doors assure safe, smooth operation and reliable performance. These doors are approved by the Underwriters' Laboratories and the Factory Mutual Insurance Companies. They *always* carry the U. L. Seal.

Write us about suggestions or complete specifications. Peelle Engineers will help you solve your door problems.

"it's
PEELLE
engineered"



BETTER-ENGINEERED PRODUCTS FOR MORE THAN 45 YEARS

PEELLE MOTORSTAIRS • FREIGHT ELEVATOR DOORS • DUMBWAITER DOORS • INDUSTRIAL DOORS

THE PEELLE COMPANY

47 STEWART AVENUE, BROOKLYN 6, N. Y.

Offices in principal cities

BRIGGS LAUNCHES NEWEST IDEA IN
HOME BUILDING AND HOME SELLING!

TWO COMPLETE BATHROOMS

in every home

WITH

BRIGGS

Beautyware

IN COLOR

It's the modern trend—the sales packed feature that will make your homes sell faster!

Two Bathrooms—instead of one! Here's a modern convenience that everybody wants.

Is it a sound idea? You bet! Because with new and proven installation economies, you can install two bathrooms *in any size house* at a minimum increase in over-all cost.

Your homes are automatically boosted into the deluxe class—making them sell faster at a higher margin of profit.

But the proof of any idea is in the doing. Let Alfred S. Levitt, Vice-President of Levitt & Sons, Inc., tell you what he thinks of the 2-bathroom idea.

"Our new community on Long Island, New York, to be known as 'Landia' will have 1700 beautiful new homes. Each of these homes will have three bedrooms and *two complete bathrooms in color*. They will sell for under \$14,000. I heartily endorse the Briggs '2-bathrooms in every home' idea."

Take a tip from the world's greatest builder. Find out for yourself how you can build this extra value into your homes at surprisingly low cost.

BRIGGS MANUFACTURING COMPANY
3001 Miller Ave. • Detroit 11, Michigan



BRIGGS Beautyware IS AVAILABLE IN 4 BEAUTIFUL COLORS AS WELL AS WHITE!

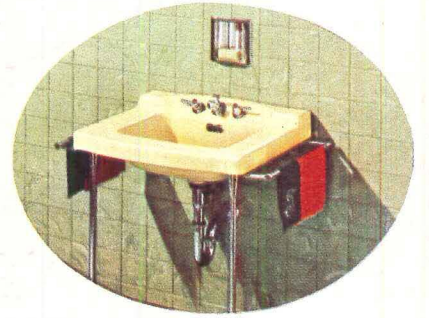

IVORY—Many decorative schemes match perfectly with Briggs Beautyware in Ivory. Walls of light yellow, aquamarine or chartreuse are suggested.



SANDSTONE—A popular shade because it harmonizes so perfectly with a wide range of decorator colors. Walls of pale green or chartreuse, ceiling in dark green, floor in yellow is a suggested combination.



SKY BLUE—Many builders have found that a decorative combination such as walls in ivory, pale lavender, dusty rose or other pastel shades lends a soft, pleasing effect.



SEA GREEN—This beautiful shade easily blends with many decorator colors. Walls of ivory, peach or light rose with ceilings in gray or pale pink is often used.

BRIGGS PASTEL COLORS were scientifically planned and developed to blend easily and harmoniously with the widest possible range of color combinations. All are basic "decorator" colors, utilized in home planning by some of the nation's most prominent interior decorators.

BACK-TO-BACK INSTALLATION OFFERS TWO BATHROOM VALUES AT UNBELIEVABLY LOW COST!

You'll be pleasantly surprised when you learn how reasonable it is to install two baths instead of one . . . how your customers will react when they learn that the addition to the monthly mortgage payments is so extremely small. In "Back-To-Back" installation where the same rough piping serves both bathrooms, greatest economies are realized . . . second best is the adjacent type of second story bath over one on the first floor utilizing the same "stack."

Don't take our word for it . . . check figures . . . check your prospects. You'll agree this is the most timely idea for by-passing competition since the inauguration of Colored Bathroom Fixtures at only 10% above White* by Briggs!

**10% extra charge for colored ware applies to complete sets including brass fittings.*



Leadership

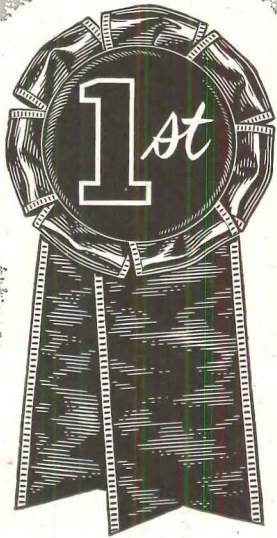

*is not the result
of luck . . .
it is won on merit*

True leadership is a challenge far greater than competition itself, for that leadership, representing the very best, challenges the capacity of a man or a business to do even better.

In October 1906 when the first SLOAN *Flush* VALVE was made, other flush valves were already on the market. Each had equal opportunity to grow—to become a contender for leadership. But none have threatened Sloan superiority.

Sloan's challenge today is in its own leadership and we are constantly striving to make our Flush Valves even better.

Our obligation is to continue to merit the preference indicated by the fact that...

more **SLOAN Flush VALVES**
are sold than all other makes combined

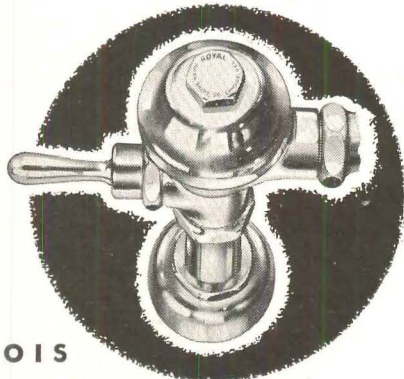

SLOAN VALVE COMPANY • CHICAGO • ILLINOIS

**FRANK
LLOYD WRIGHT**

SPECIFIES HOOD RUBBER TILE

for unique new research and development tower at
S. C. Johnson & Son, Inc.



*Interior view of tower showing use of
Hood Rubber Tile in the laboratories*



With the dedication on November 17 of the new addition to the S. C. Johnson & Son, Inc. administration building at Racine, Wisconsin, another chapter was written in the long list of architectural masterpieces designed by America's most noted architect, Frank Lloyd Wright.

To accomplish this work, many unique construction principles were incorporated . . . 20 miles of glass-tubing walls . . . 15 floors cantilevered from the central core . . . and the 40 square foot tower of laboratories and offices is supported at ground level by a base only 13 feet across at the narrowest point!

To blend with the interior decor of this modern-as-tomorrow tower, Mr. Wright needed flooring of a special color. To do this job, he specified Hood Rubber Tile, and today, and for years to come, personnel working in the fifteen floors of this historic tower will enjoy the comfort, quiet and blending beauty of this longer-lasting tile. Let Mr. Wright's choice of Hood Rubber Tile be your guide from now on and specify the flooring that has proven itself *better*, for more than 26 years.

Drop us a line today and full information will be on its way by return mail.

YEARS OF BETTER FLOORING FROM YEARS OF BETTER RESEARCH





**"Simplest Solutions
to Special Problems..."**

***again offered by plywood
concrete form panels***

THE huge spiral ramps and reinforced concrete supports of the new University of Washington stadium grandstand presented several special form problems: all concrete surfaces were curved; ramp floor-slab thicknesses varied to provide drainage; minimum form costs were required; exposed surfaces had to be smooth, uniform, fin-free.

Douglas fir plywood forms, according to Elmer Strand, partner of Strand & Son, "offered the simplest and least expensive solution. Panels can be re-used many times. They're easy to fabricate into cost-cutting built-up sections and easily bent to form curved surfaces."

Another example of this fact: large job or small . . . versatile plywood solves more form problems, more satisfactorily, more often.

Spectacular is the word for this \$1,500,000 addition to the University of Washington football stadium, Seattle. The design was prepared by George W. Stoddard and Associates, Seattle, represented by Francis E. Huggard and architect N. Torbitt. Structural engineer: Sigmund Ivarson. General Contractors: Strang & Son, Seattle; J. H. Wallstrom, superintendent. John Paul Jones was supervising architect for the University, represented by A. O. Whipple. Also representing the university was Charles C. May, superintendent of buildings and grounds.

Douglas Fir
Plywood

AMERICA'S

Plywood Gives Multiple Re-Use, Reduces Labor and Finishing

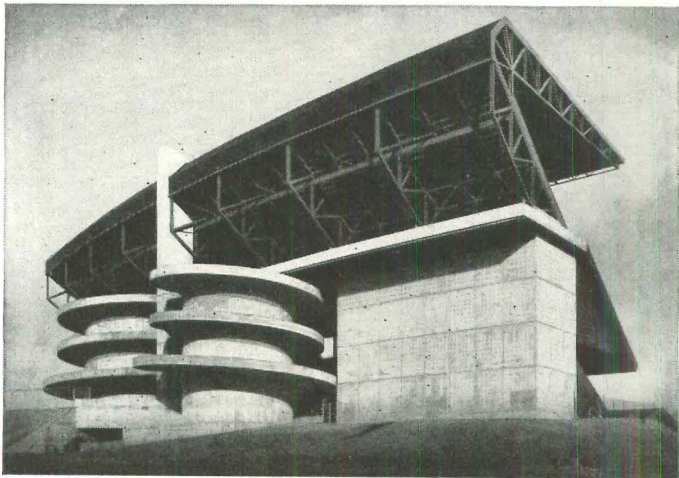

Twin spiral ramps—shaped like huge gears on 56' hollow concrete shafts—keep traffic flowing smoothly. On central shafts and the 4' guard rails, 3/4" plywood served as form liner, with lumber sheathing backed by 2x4 studs, 16" o.c. and double 2x4 wales, spaced at about two feet. The 4' wide form sections were bent to required curvature by inserting wooden shims between studs and walers. Sections were stripped, re-erected and bent to next required radius without reconstructing the basic form framework. On the 9"-thick walls of the main support, 3/4" plywood served as combined lining-sheathing. In addition to workability and re-use factors, finishing time and costs were reduced because of the smooth, fin-free surfaces so characteristic of plywood form work.

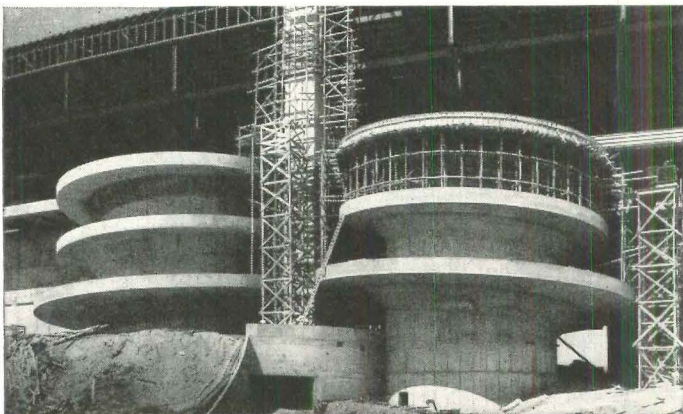

Large, Light, Strong Real Wood Panels

For additional data on Douglas fir plywood for concrete form work, write: Douglas Fir Plywood Association, Tacoma 2, Washington. Of particular interest are two booklets: "Concrete Forms of Douglas Fir Plywood" and "Handling Plyform".

BUSIEST BUILDING MATERIAL

For Smooth, Fin-Free Concrete Surfaces...

PLYFORM

Concrete Form Panels

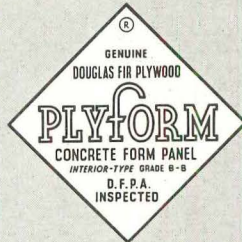

Smooth, fin-free surfaces . . . ease of handling . . . strength, rigidity, tightness . . . superior nail holding qualities . . . cost-cutting re-use factors—these are primary advantages of Plyform®. Highly moisture-resistant glues used in Plyform panels permit multiple re-use (as many as 10 to 15 are not unusual). For the greatest possible panel re-use, however, specify Exterior-type EXT-DFPA® Concrete Form grade of Douglas fir plywood—bonded with completely waterproof phenolic resin adhesive. For special architectural concrete, requiring the finest possible finish, the architect or contractor may specify Exterior-type or Interior-type Douglas fir plywood in grades having "A" face veneer—or one of the new plastic-surfaced panels.

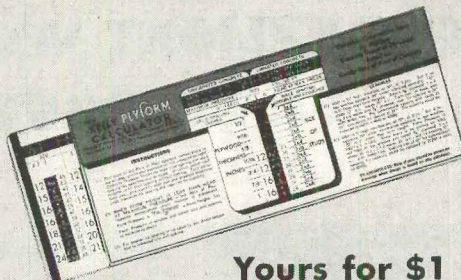

Yours for \$1

New Keely PlyForm calculator gives construction data for plywood forms, based on hourly rate of pour. Complete with leaflet, "Design Assumptions for New Keely Calculator." Send coupon now!

DOUGLAS FIR PLYWOOD ASSOCIATION
TACOMA 2, WASHINGTON (Good in USA only)

Please send me Keely Calculators. I enclose \$1.00 each to cover costs.

Name

Address

City Zone State

© PlyForm and EXT-DFPA are registered trademarks of the Douglas Fir Plywood Association



Daylight Engineered—International Business Machines Plant No. 2, Poughkeepsie, New York.
 Architect: Seelye, Stevenson & Value. Contractor: G. D. Campbell Builders Co., Inc.

HOW TO MAKE DAYLIGHT WORK OVERTIME ... THROUGH Daylight Engineering

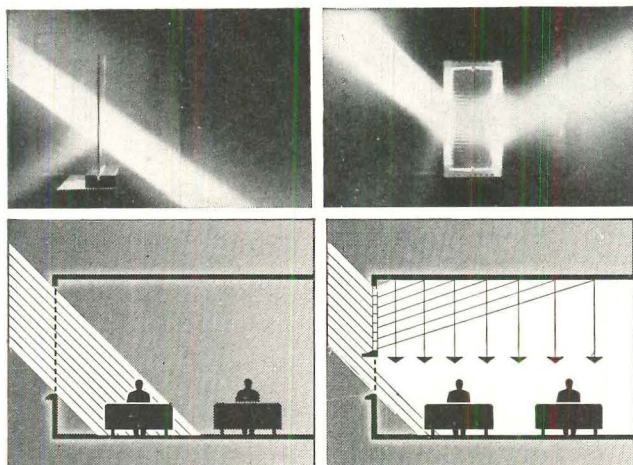

Direct sun causes uncomfortable brightness near windows, extreme contrast in other parts of room. Insulux Fenestration (glass block plus vision strip) directs and spreads daylight to ceiling, keeps brightness at comfortable levels, provides vision and ventilation.

You can make free daylight work overtime for any client for whom you are planning a building.

Daylight Engineers can help you create an Insulux Fenestration System that will practically turn your building with the sun all day. It eliminates objectionable glare—morning, noon, or afternoon.

An Insulux Fenestration System will insure privacy with light . . . provide protection against dust, dirt, and prowlers. It is permanent, low in maintenance, sanitary, sound reducing, thermal insulating, and fire resisting.

For detailed information, write: Daylight Engineering Laboratory, Dept. MB-1, Box 1035, Toledo 1, Ohio. Insulux Division, American Structural Products Company, subsidiary of Owens-Illinois Glass Company.



INSULUX FENESTRATION SYSTEMS

— by the pioneers of Daylight Engineering

Q: Why is Thermopane's Bondermetic Seal* important to you?

A:

Because this metal-to-glass seal is *airtight*—hermetically sealed. The clean, dry insulating air between the panes of *Thermopane** is not subject to changes in moisture content. No desiccant is necessary to absorb excess interior moisture. The sealed air space has a uniform ability to insulate against the loss of heat.

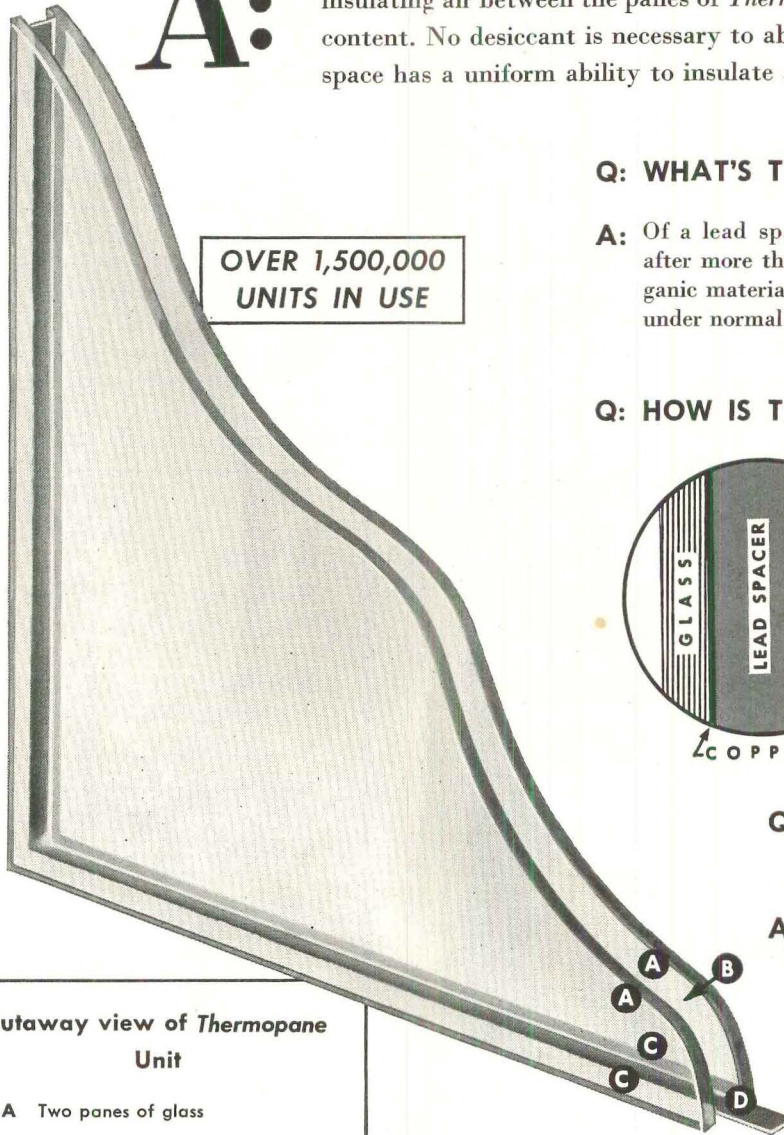

OVER 1,500,000 UNITS IN USE

Q: WHAT'S THE SEAL MADE OF?

A: Of a lead spacer and a special copper alloy we developed after more than 2,000 tests with all sorts of organic and inorganic materials. These durable metals will not corrode or rust under normal conditions. They are flexible to withstand strain.

Q: HOW IS THIS SEAL PUT ON?

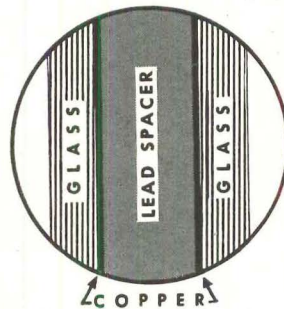

A: A continuous strip of copper is bonded to the inner surface along the edge of each pane . . . then the lead spacer is heat-bonded to the copper alloy. Glass, copper band and lead spacer are joined into one strong, solid unit.

Q: HOW DO WE GET THE AIR DRY AND ASSURE AN AIRTIGHT SEAL?

A: Following this assembly, filtered, dehydrated air is passed through the unit for a predetermined length of time to remove moisture-laden air. Each *Thermopane* unit is then tested by a scientific method so sensitive that an airtight seal and maximum performance are assured.

Cutaway view of Thermopane Unit

- AA Two panes of glass
- B Space for dry, clean air
- CC Copper alloy band } Bondermetic Seal
- D Lead spacer }

For clear vision and trouble-free performance, insulating glass is only as good as its seal. These are some of the reasons it is important for you to insist upon *Thermopane*, made in the U. S. solely by Libbey-Owens-Ford.

Get complete information on *Thermopane* insulating glass from an L-O-F Distributor listed under *Glass* in the yellow pages of your phone book. Or write Libbey-Owens-Ford Glass Company, 9511 Nicholas Building, Toledo 3, Ohio.



Thermopane

LOOK FOR THE NAME ON THE SEAL BETWEEN THE PANES

FOR BETTER VISION SPECIFY THERMOPANE MADE WITH POLISHED PLATE GLASS

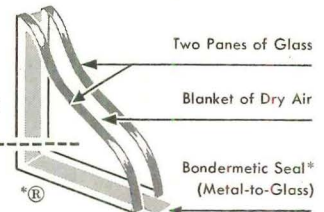

PRODUCT NEWS

SELF-CONTAINED WALL FURNACE has circulating fan for use during summer.

A complete automatic central heating system, the Delta wall furnace lends itself to the small budget-built home—in service and price. Having an hourly output of 52,000 Btu, this new oil fired unit costs about \$240. Thermostatic controls maintain desired temperatures and an automatic safety shut-off prevents overheating. No ductwork or piping is necessary; built-in registers

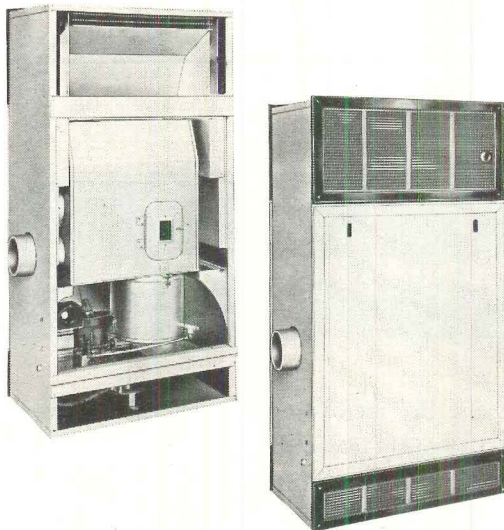

Centrally located in the typical five room plan, a Delta wall furnace will deliver heat to the entire living area.

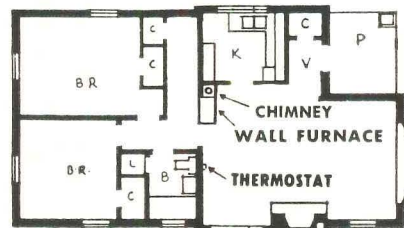

on both sides of the unit are said to assure equal distribution of warm air to all parts of the house. To regulate the volume of air in one or more rooms, vanes are directed by a simple turn of a knob. An additional feature of the model is its two-speed blower fan which may be utilized during summer months to circulate unheated air. Overall height of Model WF-100 is 5 ft., width 31 in., and depth adjustable to either 18 or 20 in. It is approved by Underwriters' Laboratories for installation directly on wood or concrete slab floor. No clearance is required between wall joists and the furnace. The unit may be connected to an adjoining chimney or a prefabricated flue.

Manufacturer: Delta Heating Corp., Jackson Heights, New York.

LOW COST UTILITY FAN KIT can be rigged together in ten minutes.

Reversing the trend to devices that save labor time, General Electric is introducing a put-it-together-yourself fan kit. G-E supplies all the parts including bolts and screws; the consumer supplies ten minutes to mount the blade and bracket to the motor—and thereby saves a few dollars. Disjoined, the package sells for only

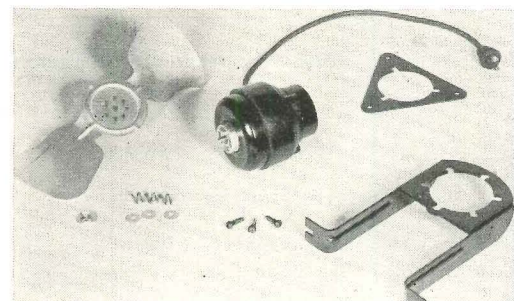

\$10.95. The fan's best feature is its adaptability. Built for use on 115 v., 60 cycle a.c. circuit it may be placed in kitchens to remove cooking odors, attics to dissipate heat, or basements and laundry rooms to relieve those areas of dampness. Its one piece cast iron housing keeps the bearing permanently aligned so that the fan will work in any position. Quiet in operation, the new fan has a 10 in. blade capable of moving 360 cu. ft. of air per minute. The 9 w. G-E unit-bearing motor, totally inclosed to keep out dirt, has a large sealed-in oil supply.

Manufacturer: General Electric, Schenectady 5, N. Y.

(Continued on page 202)

WAYLITE interior Zion Evangelical Lutheran Church, Chicago

Architect: Herbert Brand • Contractor: Crouch-Walker

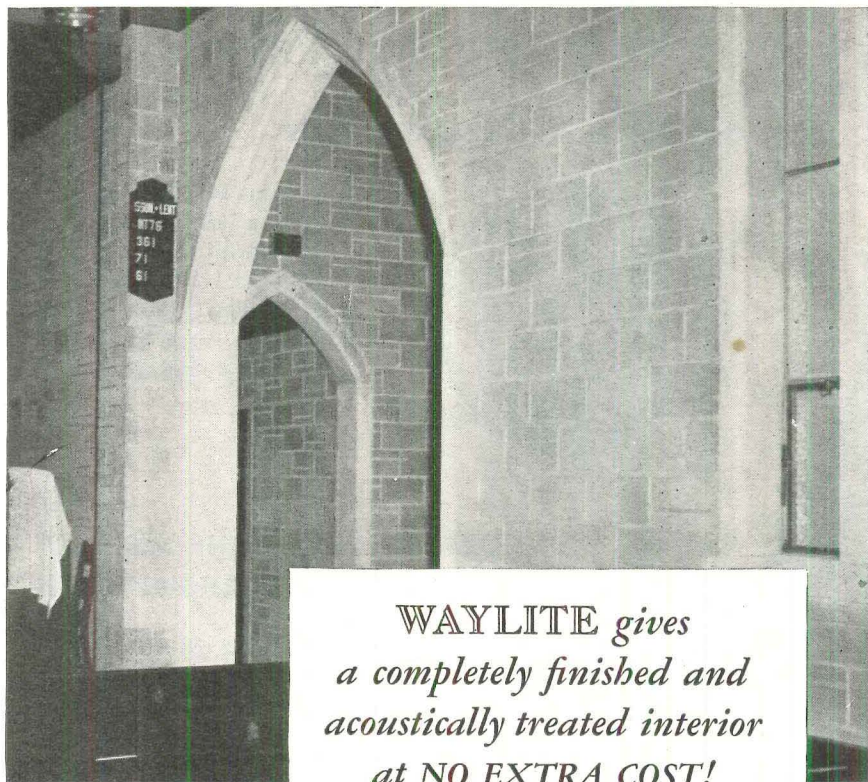

WAYLITE gives
a completely finished and
acoustically treated interior
at NO EXTRA COST!

A Waylite masonry structural wall with the interior surface left exposed provides a 3-fold advantage for many types of structures. The soft lights and shadows of the textured grey surface is attractive. Waylite masonry has a noise coefficient of up to 50% and provides adequate acoustical treatment. It is a very economical architectural treatment because plaster or other finishes are eliminated.

You'll find such walls useful in churches, theatres, schools and many other types of buildings. You pay only for a structural wall and without further cost you have an attractive interior surface—completely finished—and acoustically treated!

For further information address Waylite Company, 105 W. Madison Street, Chicago 2, or Box 30, Bethlehem, Pennsylvania.

WAYLITE
MASONRY UNITS



sleep's unaffected...his factory's protected

Worry! Fret! Loss of sleep thinking about fire cutting into production time . . . destroying valuable records . . . costing lives of employees . . . all are anxieties of the past when your factory's protected with modern, approved C-O-TWO Fire Protection Equipment.

For example, the new C-O-TWO Low Pressure Carbon Dioxide Type Fire Extinguishing Systems keynote flexibility to meet your particular fire protection needs. Flammable liquids, electrical equipment, storage and manufacturing processes can all be made firesafe from a single low pressure carbon dioxide storage tank . . . capacities range from one to fifty tons of fire killing carbon dioxide. If fire should strike the fast-acting, non-conducting carbon dioxide extinguishes the blaze

in seconds . . . no water damage, no lingering odors.

Further, when a C-O-TWO Smoke or Heat Fire Detecting System is used in combination with a C-O-TWO Low Pressure Carbon Dioxide Type Fire Extinguishing System, the first trace of smoke or spark of fire in a protected area immediately sounds an alarm . . . then the fire quenching carbon dioxide is readily released into the threatened area.

So, whatever your fire protection problem, let an expert C-O-TWO Fire Protection Engineer help you in planning complete and up-to-date fire protection facilities now. Write us today . . . tell us about your particular fire hazards, our experience is at your disposal . . . no obligation of course.



C-O-TWO FIRE EQUIPMENT COMPANY

NEWARK 1 • NEW JERSEY

Sales and Service in the Principal Cities of United States and Canada

Affiliated with Pyrene Manufacturing Company

MANUFACTURERS OF APPROVED FIRE PROTECTION EQUIPMENT

Squeez-Grip Carbon Dioxide Type Fire Extinguishers • Dry Chemical Type Fire Extinguishers • Built-In Smoke and Heat Fire Detecting Systems
Built-In High Pressure and Low Pressure Carbon Dioxide Type Fire Extinguishing Systems

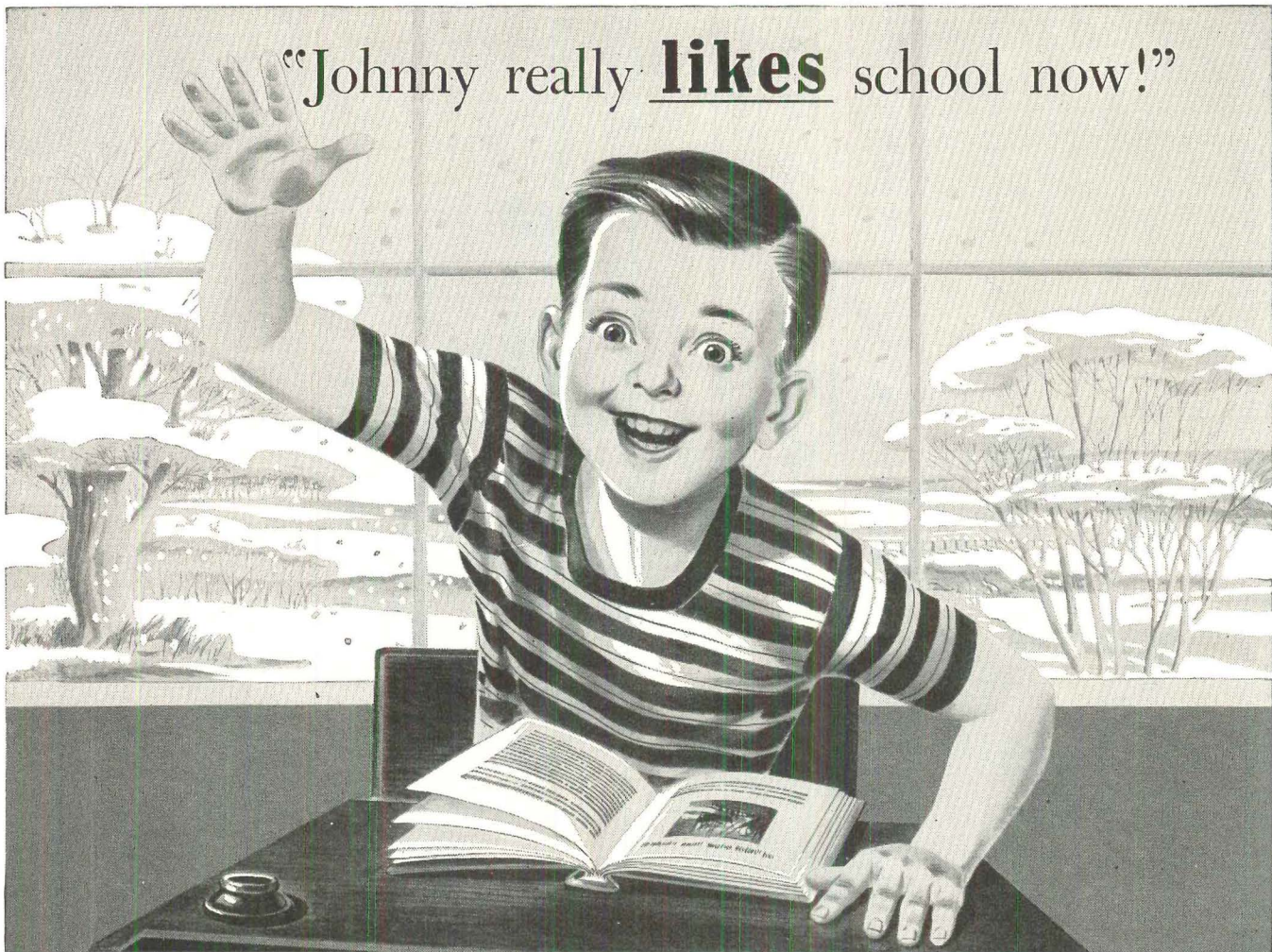

Steel pipe is first choice for radiant heated schools

It's a good thing Shakespeare didn't live in our day for he would have had to revise those familiar lines about the school boy . . . "creeping like snail, unwillingly to school!" Our millions of grand American kids really *like* school now!

And why shouldn't they? Americans believe firmly in the right of every youngster to get a good start in life! As a result our schools not only stimulate young minds but provide every comfort that science can devise and money can buy to make learning enjoyable, healthful and comfortable.

Good lighting, ventilation, and heating are "musts" in America's modern schools. In the newest ones even the advantages of *radiant* heating are included. And because "the best is none too good" steel pipe is first choice for these radiant installations.

There are many reasons why! Steel pipe has been proved in more than 60 years' service in conventional hot water heating systems and, in addition, meets the *specific* piping requirements of radiant installations in every particular . . . from economical first cost to complete mechanical adaptability!

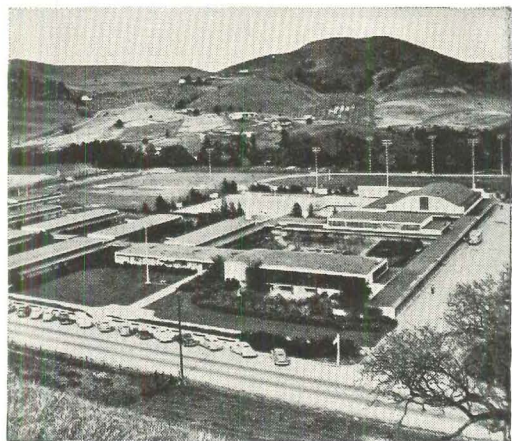

Modern schools like this new Acalanes Union High School, Lafayette, California, use steel pipe in floor panel radiant heating installations.

COMMITTEE ON STEEL PIPE RESEARCH

AMERICAN IRON AND STEEL INSTITUTE

350 Fifth Avenue, New York 1, N. Y.

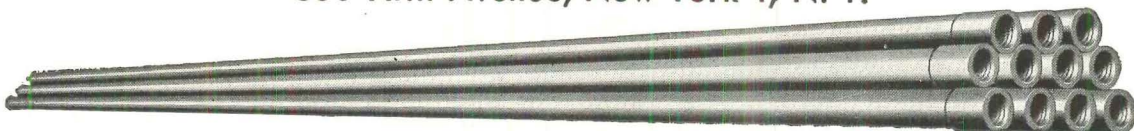



House & Garden

... for the owner-builder market

Nothing make-believe in this picture

Real houses...not dreams on paper! That's what you're interested in. And that's what interests House & Garden's owner-builders. Their biggest and most important investment is the house they build for themselves. An investment they can *afford* because 58.1% of them have incomes of \$10,000 and over; 40.8 have incomes of \$15,000 and over. Because they are the kind of people who want made-to-order houses, your quality building materials will interest them. Tell them your story in House & Garden to make sure they will *specify your product*.

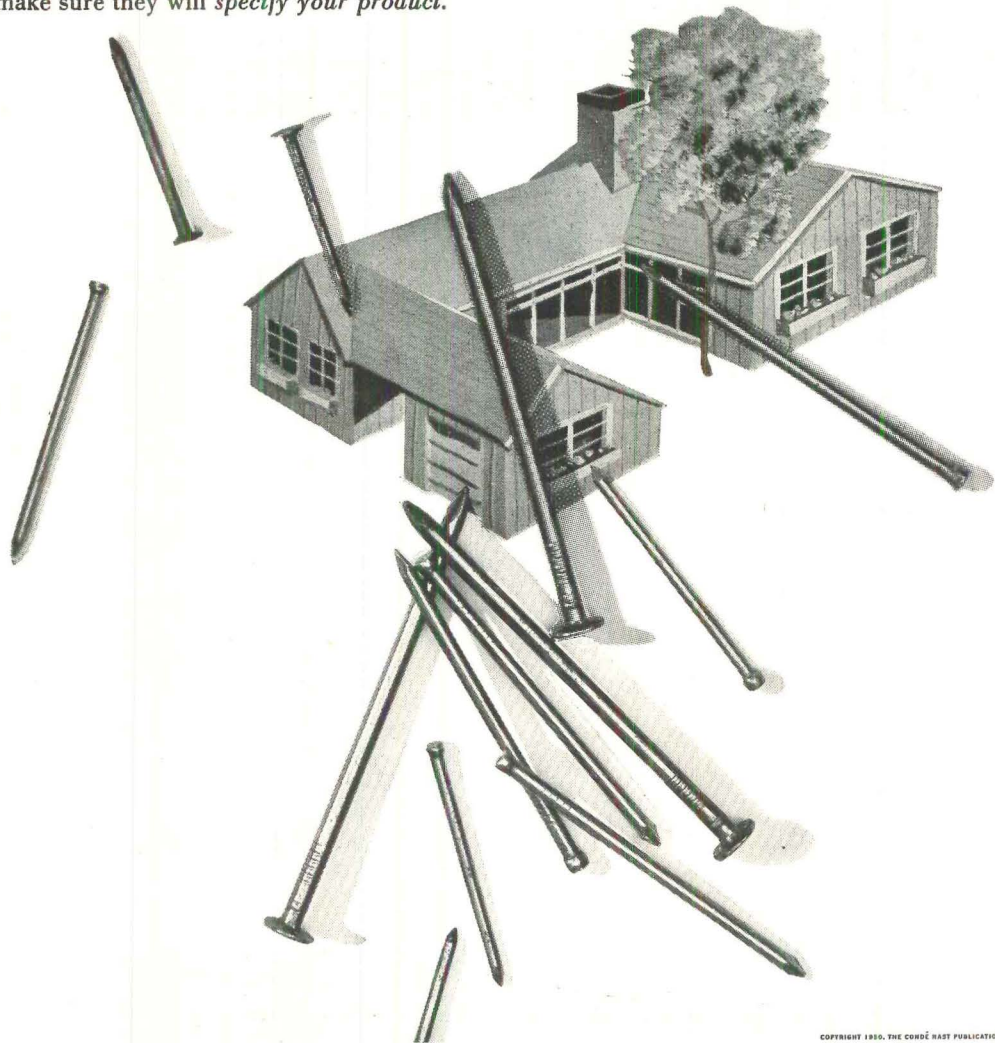

COPYRIGHT 1980, THE CORDE RAST PUBLICATIONS INC.

PRODUCT NEWS

FRAMELESS SCREEN AND STORM WINDOW kept taut by a tension device.

Columbia Mills' trim aluminum screen and plastic storm sash may be used on all types of double hung windows. Moderately priced, this convenient combination unit has no stiles or side members. Instead, an automatic tensioning device keeps the side edges of the aluminum mesh screen or clear plastic film tightly sealed against the blind stops. Both the screen and storm sash

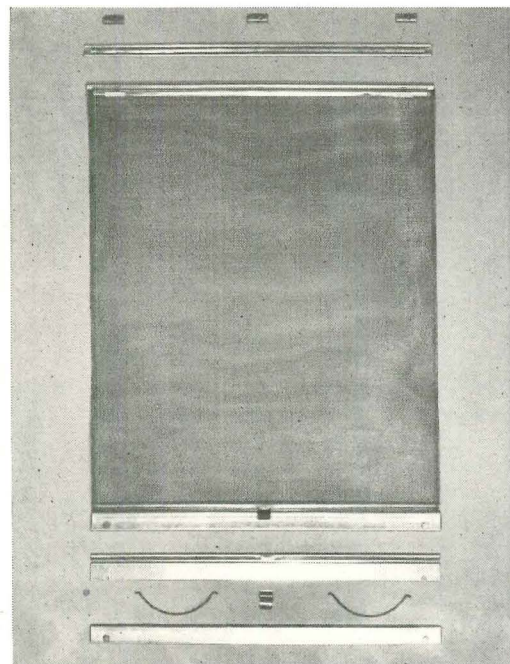
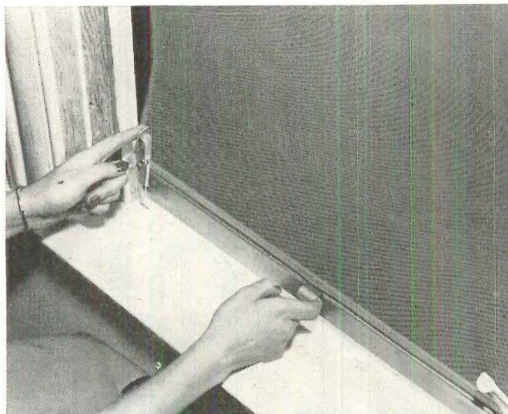

utilize the same top and bottom rails and tension locks. All permanent members, as well as the screen, are of aluminum and so will not stain the house. Also, they do not require seasonal painting. The windows may be installed from inside the house and are easy to open, close or interchange. Either sash may be rolled into a neat bundle for storage without impairing its shape or appearance. Retail price for the complete unit 2 ft. wide and 2 ft. 10 in. long is \$6.74; for the 4 ft. wide and 5 ft. 2 in. long, \$14.49.

Manufacturer: The Columbia Mills, Inc., 225 Fifth Ave., New York, N. Y.

DRAPERIES AND WINDOW SHADES are made of woven wood and bamboo strips.

Novel window treatment can be attained with two new Holland curtain and shade materials, Bambino and Wood Loom. The first (pictured at left) is made of thin bamboo strips; the sec-

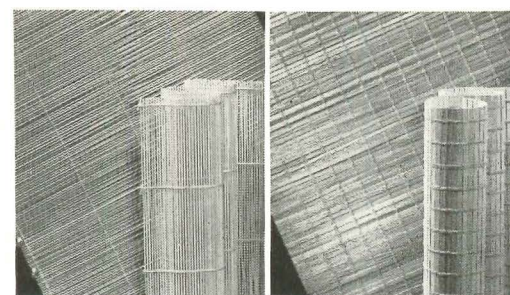

ond, of narrow staves of Swedish wood woven together with multiple ply, long staple, combed yarn. Hung as curtains, the wood fabrics glide easily on traverse tracks and used as shades, they roll up compactly on spring rollers. Both can be obtained in any length and in widths up to 10 ft. Approximate retail prices for Bambino are 90 cents per sq. ft. for natural, \$1.20 for white or any of 14 standard colors. Wood Loom is \$1.10 per sq. ft. for natural or walnut finish and \$1.40 for white and colors. For an additional fee of \$5 per order the materials are painted to match color samples.

The company also makes sliding walls and screens of plastic laminated with wood, which can be used as decorative room dividers or wardrobe closures.

Manufacturer: Holland Shade Co., 999 Third Ave., New York, N. Y.

(Continued on page 206)

BETTER Colors **WITH Premium Quality**

BETTER Wear

BETTER Floors



There are four good reasons why Azphlex grease-resistant asphalt tile offers such remarkable qualities:

- 1 **Tremolite Talc**, its mineral filler, is highly stable, and totally resistant to alkalis, acids and other chemicals. It is fine-grained and microscopically fibrous.
 - 2 **Asbestos Fiber** used in Azphlex is of the Chrysotile variety, noted for its fine texture, flexibility, strength and resistance to fire.
 - 3 **Thermoplastic Binder** is a polystyrene—a scientifically proportioned composition of low molecular weight—which is plasticized with aromatic, petroleum-derived oils and is unaffected by moisture, acids, alkalis, oxidation, etc. Uniformity and perfect blending are assured because the binder is cooked at high temperature in large batches.
- Color Pigments** used in Azphlex are permanent and alkali resistant.



When you specify grease-resistant, premium-quality Azphlex Asphalt Tile—you can know that you're giving your clients better, longer-lasting floors at lower cost. Get full information and sample tiles from your AZROCK-AZPHLEX Dealer, or write to Dept. A.

UVALDE ROCK ASPHALT CO.

Makers of AZROCK and AZPHLEX Asphalt Tile

FROST BANK BLDG. • SAN ANTONIO, TEXAS

AMERICAN-Standard

First in heating . . . first in plumbing

These modern schools rely on AMERICAN-Standard

■ In many respects these schools are vastly different. They're located in widely separated sections of the country. They're different in size. And they're different in architectural design. However, like hundreds of other fine educational institutions, they're in perfect agreement as to the best heating equipment and plumbing fixtures to use: they're all American-Standard equipped.

In schools all over the country American-Standard Heating Equipment and Plumbing Fixtures have proved to be

efficient, dependable, easy-to-maintain, even under the most rugged service conditions.

Whatever your building or remodeling plans . . . school, house, hospital, hotel or large industrial building . . . you'll find the right products for your needs in the *complete* line of American-Standard Heating Equipment and Plumbing Fixtures. Ask your heating and plumbing contractor for details. **American Radiator & Standard Sanitary Corporation**, P. O. Box 1226, Pittsburgh 30, Pennsylvania.



JULIAN CURTISS SCHOOL, Greenwich, Connecticut.
Architects: W. B. Tubby, Coffin & Coffin, & Philip N. Sunderland, Inc., Associated Architects.
Heating and Plumbing Contractor: Hauxwell & Smith, Inc.
Wholesale Distributor: Center Heating & Oil Supplies Co.

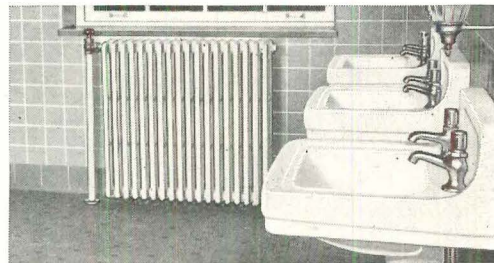

In the Julian Curtiss School this compact, slim-tubed **ARCO LEGLESS RADIATOR** provides exceptionally quick heating. The **LUCERNE LAVATORIES** feature deep, square bowls and splash backs, and are made of durable genuine vitreous china.



MONTECITO ELEMENTARY SCHOOL, Martinez, California.
Architects: Bamberger & Reid, San Francisco
Heating and Plumbing Contractor: Morrill Plumbing & Heating, Oakland

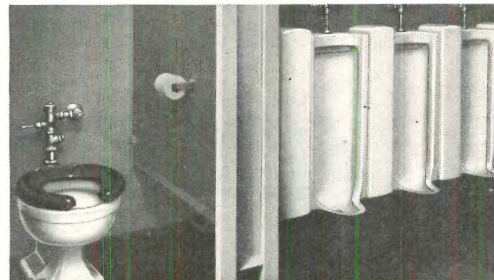

This neat rest room of the Montecito Elementary School is equipped with the **DEVORO WATER CLOSETS** and **CHINA URINALS**. Of genuine vitreous china these fixtures are non-absorbent, easy to clean. Flushing action is fast and thorough.



ROSEDALE SCHOOL, Denver, Colorado
Architects: Raymond Harry Ervin and Associates
Mechanical Engineers: Marshall & Johnson
General Contractor: E. L. Hobbs Construction Company
Plumbing Contractor: Grabb Plumbing & Heating Company



Steady and adequate heat is automatically supplied the Rosedale School by this **STANDARD GAS BOILER**. Heating surfaces, burners and controls are all coordinated to give maximum heat output with minimum operating and maintenance costs.

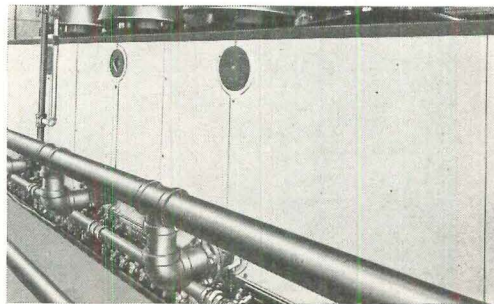

Serving home and industry

AMERICAN-STANDARD • AMERICAN BLOWER • CHURCH SEATS • DETROIT LUBRICATOR • KEWANEE BOILERS • ROSS HEATER • TONAWANDA IRON



LICHTY —
OF "GRIN AND BEAR IT"

*"Comrade Agent send valuable
U. S. Industrial Secret ... in America,*

EVERYTHING HINGES ON IT!"

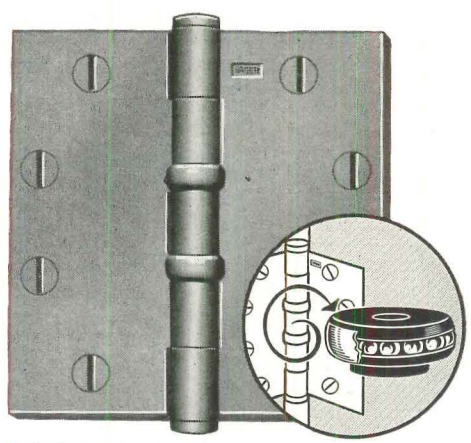

HAGER BB 1193 FBT
BRASS BUTTON TIP BALL BEARING BUTT
For added beauty and permanent trim appearance,
specify all-weather non-corrosive solid brass butts.

The WEIGHT Swings on HARDENED STEEL... Not BRASS!

Knuckle weight is functionally engineered on Hager Ball Bearing Butts to lie against special hardened steel top races. The brass cup, which contains the races and the ball bearings, supports no weight... is subject to no erosive friction that may later wear out or impair performance.

Highest quality chrome steel balls allow the knuckle to glide smoothly and evenly over tempered steel races. Leaves are beveled at the joint. Trim, square outer edges are finely milled sharp and clean.

Specify Hager "BB" Butts on jobs calling for average frequency door service. Hager Frictionless ball bearing gliding action permits even the heaviest doors to silently float back and forth.

C. Hager & Sons Hinge Mfg. Co. • St. Louis, Mo.
Founded 1849—Every Hager Hinge Swings on 100 Years of Experience



© 1950

BUILDERS REVEAL SECRETS of New Ways to Insulate and Plaster, Get Better Results, Cut Time and Cost

RADIANT HEATING SPECIALIST FINDS INSULATING CONCRETE INCREASES EFFICIENCY!

CRYSTAL LAKE, ILL., Nov. 5, 1950 — More than 300 floor panel radiant heating installations have taught Miles Westbrook, local heating contractor, some interesting facts about insulation. As a result of his experience, he specifies that a layer of Zonolite Insulating Concrete must be laid over the levelled ground before radiant heating coils are installed. Says Mr. Westbrook, "Heat loss to the earth from a floor slab without insulating concrete is usually high. Zonolite Insulating Concrete keeps heat from going downward and, over a period of time, saves a good deal of fuel."

Mr. Westbrook adds, "Over several seasons, we have found in homes where floor coils were laid over Zonolite Insulating Concrete, that *override and lag* were much less of a problem . . . than when coils were laid over cinders or other insulation. Also . . . panels *without* a Zonolite insulating base needed much *higher* water temperatures to maintain comfort."

Veteran Contractor Tells How He Does Better Plastering with Zonolite!

CINCINNATI, OHIO, Nov. 15, 1950— C. W. Sittason, local contractor who has been in the plastering business for over 29 years, has found that he can eliminate many plastering difficulties by using Zonolite Plaster Aggregate. After using Zonolite plaster on a large Cincinnati ceiling job he said, "Zonolite plaster adhered to the base coat better . . . drop-outs and over-night laps gave no trouble . . . screeding alone produced a finish that looked like troweling!" He also found his men showed great enthusiasm in working with Zonolite.

Mr. Sittason himself enthusiastically states, "I heartily recommend Zonolite Plaster Aggregate and Zonolite Acoustical Plastic to improve the quality of *any* plastering job!"

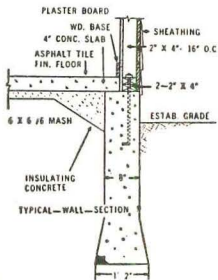

House completely insulated in 2 hours!

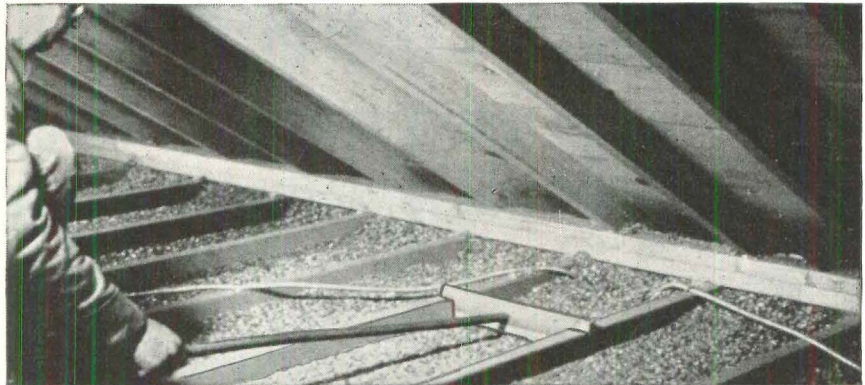

SIOUX FALLS, SOUTH DAKOTA, Oct. 10—Robert Stoneall, local building contractor, reveals his unique use of Zonolite Vermiculite Insulation to completely insulate a home in only 2 hours with just 2 men—including time spent unloading bags and cleaning up after the job is finished! His time and money-saving method enables him to complete side-wall and attic insulation in a 24' x 30' house in a fraction of the normal time. Mr. Stoneall says,

"You can't beat ZONOLITE for insulation and ease of installation."

This is Stone-

all's method: By putting the 2 x 4 plates *on top of the ceiling joists*, he leaves access in the attic so that ZONOLITE may be poured down the sidewalls from the top.

Sidewalls are poured first. The light granular nature of the material permits it to run freely between the studding, all the way to the foundation, filling the space to a uniform thickness. The wall is vibrated lightly with a rubber mallet to produce settlement. Spaces under window openings are filled as the lath is installed.

When sidewalls are full, the remaining bags of ZONOLITE are dumped in the center of the attic, then raked and leveled between the joists to a 3 $\frac{5}{8}$ in. thickness.

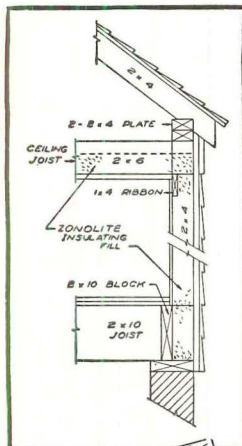

ZONOLITE COMPANY, 135 S. LaSalle St., Chicago 3, Ill., Dept. AF-01

**PUT NEW TIME AND LABOR
SAVING ZONOLITE INSULATION
TO WORK FOR YOU! GET
FULL DETAILS TODAY!**

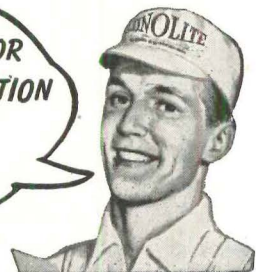

*Zonolite is a registered trade mark

Zonolite Company, 135 S. LaSalle St., Dept. AF-01
Chicago 3, Illinois

Please send me booklet G-24 on Zonolite products, including Zonolite Insulating Fill.

Name.....

Address.....

City..... Zone..... State.....



**AT YOUR
LUMBER OR BUILDING
MATERIAL DEALERS'**

PRODUCT NEWS

GYPSUM WALLBOARD with aluminum foil backing is effective insulation.

Wallboard, insulation and vapor seal go up in one fell swoop with aluminum foil-backed gypsum board. Although on the market for a few years, this timesaving construction item is just now catching on in the building trade—its increased popularity coinciding with current interest in the value of reflective insulation. Still in plentiful supply despite the curtailment of alumi-

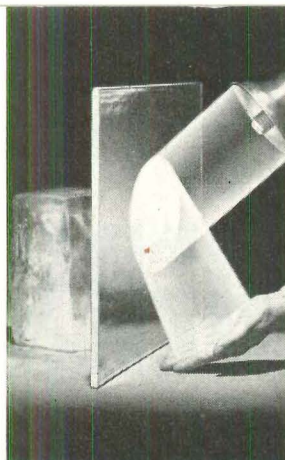

Most heat rays that hit the aluminum foil surface bounce off, as demonstrated with the heat lamp. Neither does water vapor penetrate a wall protected by a foil barrier (far right).

ONLY Skylike® LIGHTING

HAS BOTH KINDS OF APPEAL

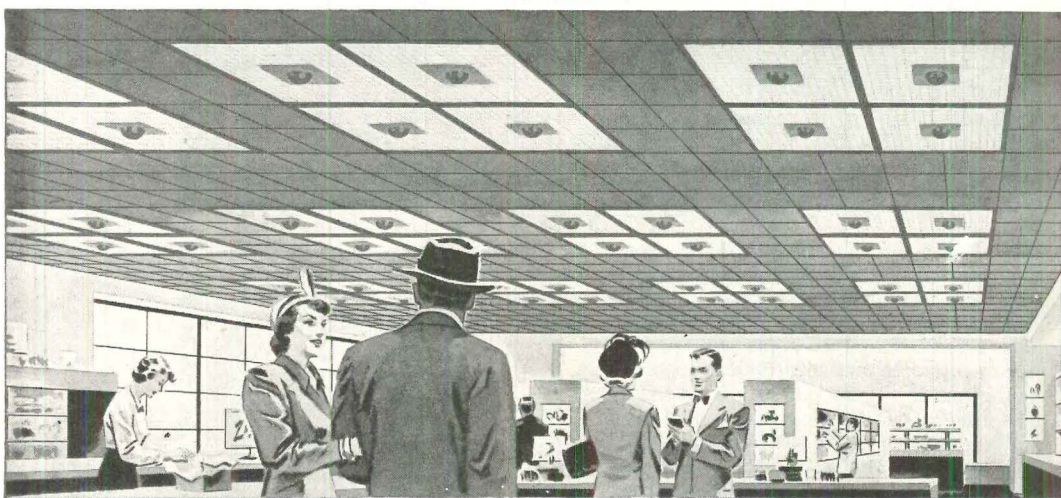

Silvered-bowl incandescent advantages

Modern fluorescent-type appearance

Naturally your clients want lighting that's up-to-date in looks (and Skylike is!). But they really get excited when they hear about Skylike's freedom from maintenance troubles—and the fact that Skylike lighting costs only $\frac{1}{2}$ to $\frac{1}{3}$ as much as other equipment delivering comparable results.

No other lighting combines all these advantages:

1. High initial and maintained light output.
2. Softly diffused shadows.
3. Low brightness and 90° shielding.
4. No flickering, blinking, or hum.
5. Warm color—most desired by merchandising experts.
6. Instant starting.
7. Variable lamp size—150- to 500-watt.
8. No light loss from darkened walls or ceilings.
9. Floor-service relamping—no ladders or scaffolds.
10. Hermetically sealed silver reflecting surface.

ARCHITECTURAL LATITUDE

Skylike units fit 24" x 24" ceiling tiles, fully or partially recessed, or may be surface mounted—in rows or patterns.



ACCENT OR DIRECTIONAL LIGHTING is readily and effectively accomplished with Skylike. A semi-silvered-bowl lamp and a simple accessory are substituted for the regular lamp.

SILVRAY
Skylike *

*Patent Pending



Send coupon for Skylike booklet

Graybar Electric Company, Inc.
Graybar Building,
420 Lexington Ave.
New York 17, New York



Please send me a copy of "Skylike Louvered Incandescent Lighting Systems".

Name _____ Title _____
Firm _____
Address _____
City _____ Zone _____ State _____
5107

num fabrication for nondefense purposes—10 manufacturers in the Gypsum Association are gluing foil to their standard size boards and gypsum plaster lath—these double-purpose products make it simple for home builders to include reflective radiant insulation in exterior walls and top floor ceilings at no additional labor cost. Unadorned, the $\frac{3}{8}$ in. gypsum wallboard sells for about \$45 to \$50 per 1,000 sq. ft., the $\frac{1}{2}$ in. from \$50 to \$57, and lath $\frac{3}{8}$ in. is about \$37 to \$40. The premium paid for the foil backing is about $1\frac{1}{2}$ cents per sq. ft. above the price of the board.

In application, the lath or wallboard is nailed to the inside of the studs of outside walls with foil side face out. Aluminum foil is said to reflect 95 per cent of the heat rays that strike its surface. Another trouble source, condensation is also met by the foil. An excellent vapor barrier, it protects building framework from moisture damage. Where there is no room for bulky or batt type insulation materials, such as in masonry walls, the gypsum lath plaster base with foil provides a very satisfactory insulation and vapor barrier. Together the gypsum and aluminum form a practical, long lived, fire resistant building material.

Information: Gypsum Association, 20 N. Wacker Dr., Chicago, Ill.

EMBOSSED ALUMINUM SHEETS can be formed easily on the job.

Adaptable for many construction uses—store fronts, partitions, signs, curtain walls—Lustrik aluminum sheets are produced in flat panels and five crisp patterns. Lightweight, the sheets handle easily and can be formed and cut on the job. They receive a chemical bath which gives them a smart Roman finish and also is said to make them highly stain and corrosion resistant. Prices, f.o.b. Philadelphia, range from about 43 cents per sq. ft. for the flat stock to \$19.75 for a 34 $\frac{1}{2}$ x 120 in. panel of the square corrugated design, pictured below left. Other patterns are rib fluted (one or both sides), round corruga-

(Continued on page 212)

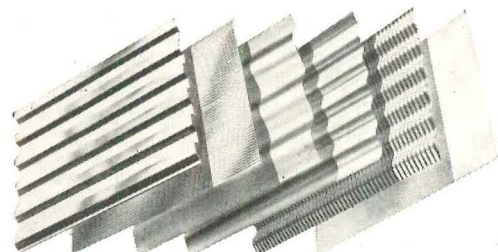

ANOTHER ADVANTAGE OF BUILDING WITH HOMASOTE . . .

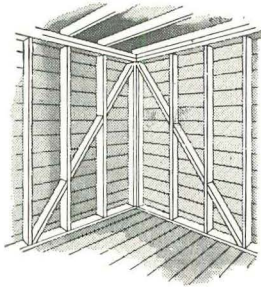

WITH
**NO
CORNER
BRACING**

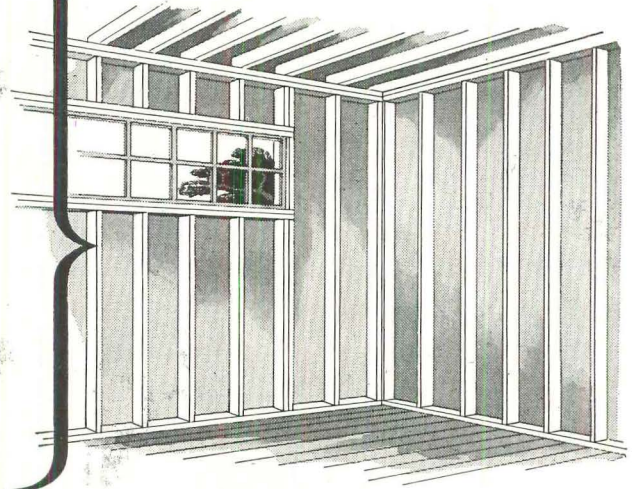

. . . Homasote greatly exceeds F.H.A. strength requirements
. . . surpasses corner-braced, horizontal wood sheathing

STANDS UP UNDER
HURRICANES,
TORNADOES, TWISTERS

SINCE 1937, Homasote has been eligible for F.H.A. Mortgage Insurance—with no corner bracing—as used in Precision-Built Construction. The F.H.A. standards require bracing strength equal to horizontal wood sheathing with corner bracing. Racking tests—by an independent laboratory—showed that Homasote, without corner bracing, has a 150% margin of safety at 1200 lbs. and a 300% margin at 2400 lbs. over these requirements. Many another test has repeatedly shown Homasote to be the strongest insulating and building board on the market.

No corner bracing is required when Homasote—in 4' widths or in greater widths up to 14'—is used on jobs under F.H.A. supervision.

Homasote is weatherproof—tested for more than 30 years under every weather condition—from the tropical to the antarctic. With its unusually low moisture absorption, low air infiltration and high resistance to water-permeability, Homasote provides the maximum in lasting insulation values and full protection against dampness.

Homasote's Big Sheets require only one third as many nails as do 4' materials. With this lower application cost and the additional savings through the elimination of corner bracing, architects and builders can safely specify Homasote sheathing for the strongest house at the lowest cost.

HOMASOTE COMPANY, Trenton 3, N. J.



. . . in Big Sheets up to 8' x 14'

. . . Oldest and strongest insulating and building board on the market

Nova Sales Co.—a wholly-owned Homasote subsidiary—distributes the Nova Roller Door, Nova-I. P. C Water-proofing Products, the Nova Shingle and Nova-Speed Shingling Clip and the Nova Loc-Nail. Write for literature.

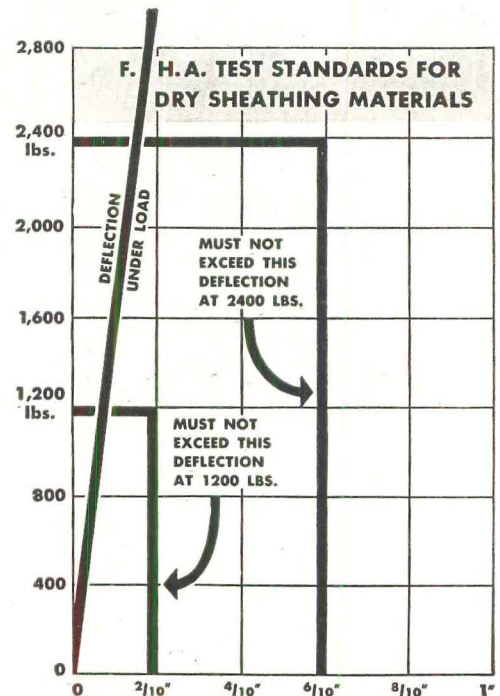

THIS CHART shows the results of racking tests made by an independent laboratory, using 8' x 8' Homasote sheathing on standard wall framing without corner bracing. At 1200 lbs. pressure, deflection could not exceed 2/10 inch; at 2400 lbs. pressure, 6/10 inch. . . The diagonal line shows that Homasote without corner bracing had a margin of safety of 150% at 1200 lbs. and 300% at 2400 lbs.

**At the 10th Air Conditioning
Exposition in Philadelphia . . .**



**. . . See these high-efficiency automatic
Anthracite heating units**

America's best fuel buy is Anthracite

With these modern Anthracite-burning units, you can offer your clients and customers the ultimate in clean heat—even heat—economical heat—trouble-free heat in abundance. See the newest models at the show, or write for descriptive literature to Anthracite Institute, 101 Park Avenue, New York City, N. Y.

ANTHRAFLO—An entirely different type of boiler-burner, with many points of design never before found in home burners. Fully automatic . . . the coal feeds direct from bin across the stationary grate. Ashes discharge into container within unit. All working parts are accessible from outside the unit. For steam, hot-water and warm-air systems. Provides year-round hot water.



ANTHRATUBE—The revolutionary design that operates at a *proved efficiency of over 80%*. The "whirling heat" principle, supported by several other field-tested innovations, give Anthratube faster response and superior performance . . . the very peak of fuel-burning efficiency! Provides year-round hot water.



MODERN ANTHRACITE STOKERS—Automatic conversion stokers are available for installation in existing boilers or furnaces—specially designed in complete boiler-burner units, such as *Motor Stoker*, *Electric-Furnaceman* and others. All offer high efficiency, small size and economical operation. All are completely automatic from bin to ash removal. Provides year-round hot water.

ANTHRACITE (HARD COAL) INSTITUTE

From one source:

**EVERYTHING
YOU WANT TO KNOW
For Electrical
Modernization**

**Get the facts,
accurate and up-to-date
via Graybar locally**

As distributor of more than 100,000 electrical items, Graybar is a logical source of the specific information you need in electrical planning of your projects.

Simply by calling the near-by Graybar office, you or your electrical contractor can get complete, accurate, *up-to-the-minute* facts about any type of electrical item—application details and any other data you need. If you want it, you can also get the help of a Graybar Specialist in any of the major electrical fields. Graybar Specialists are highly experienced and will gladly join their specialized electrical knowledge with yours in the planning of unusual or complex layouts.

Then—see that all the electrical items are ordered from Graybar. You'll be sure your specifications will be carried out to the letter; you'll stand the best chance of on-schedule deliveries, thus help to make sure everything will go according to plan on the job site.

5106

HELP ON WIRING MODERNIZATION

As a distributor of wire and cable, conduit, boxes and fittings, and thousands of other wiring materials and devices, Graybar is a convenient local source for all your project's wiring needs. Our Inside Construction Specialists are ready to help you with accurate information and reliable recommendations concerning wiring materials for any job.

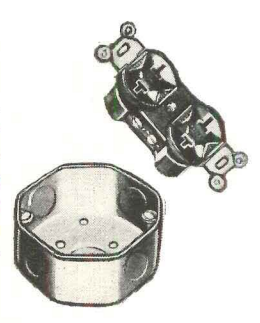

HELP ON POWER MODERNIZATION



If your project calls for motors or controls—of any type—the Graybar Power Apparatus Specialist is the man to call if you want help. We distribute a wide selection of G-E motors and controls, for general or special purposes. Graybar also supplies everything for intra-plant power distribution.

HELP ON LIGHTING MODERNIZATION

Graybar has planned and supplied lighting systems of every type—indoors and out. A Graybar Lighting Specialist can help you choose from *the most complete selection of lighting units available* from any one source. He can, and will, impartially recommend the lighting equipment that's best for each project.

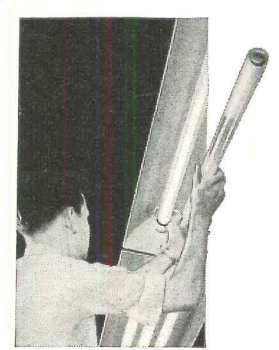

HELP ON VENTILATION MODERNIZATION

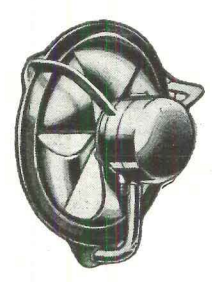

Graybar can help you determine the proper kind and amount of ventilation needed for removing excess heat, fumes, or any other purpose. Graybar distributes a full line of fans and blowers plus related accessories for the ventilation of any room or building section. They're all by ILG, first choice in the field of ventilation.

HELP ON COMMUNICATION MODERNIZATION

For any communication need, simple or complex, a Graybar Signaling Specialist can help you choose the best type of equipment and help you plan the most efficient layout. From near-by Graybar you can get detailed information on annunciator or audible paging systems, Teletalk amplified voice systems; fire alarm systems and signaling systems for special purposes.



To make sure it's Right . . . be sure to have this team work with you in your electrical planning.

Your Electrical Contractor and . . .

Graybar

IN OVER 100 PRINCIPAL CITIES



Thorsealing can be Beautiful



**WHISK
BROOM**



**STIPPLED
FINISH**



**HEAVY
BROOM**



**LINEN
FINISH**

THOROSEALING gives to the architect and builder, aside from masonry protection, distinctive textures and the opportunity to present finish coats of QUICKSEAL, in sixteen beautiful tints, without reflection or glare.

ACTUAL PHOTOGRAPHS OF THOROSEAL TEXTURES

With very little effort, many distinctive textures can be produced by the workman with THOROSEAL.



Mercy Hospital, Miami, Florida. Commencing of THOROSEAL applications. Architect—Steward and Skinner, Miami, Florida. Contractor—J. Y. Gooch Co., Miami, Florida. The finished THOROSEAL job is shown at the top of the page.

Complete Masonry Protection

Can be secured from foundation to roof with THOROSEAL. Beautiful finish coats of QUICKSEAL can be secured without hiding the THOROSEAL texture.

WATERPLUG
To Stop Leaks
THOROSEAL
To Seal Surface
QUICKSEAL
For Beautiful Finish

Write today for our new 20 page brochure 17-A and designer's wall chart.

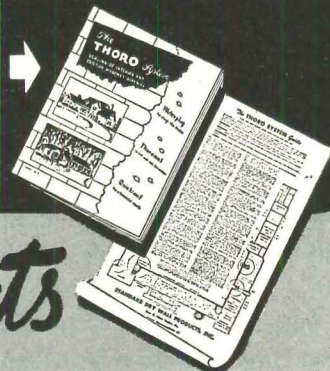

Standard DryWall Products

NEW EAGLE PENNSYLVANIA

Everybody's happy when you select **MODINE CONVECTOR RADIATION**

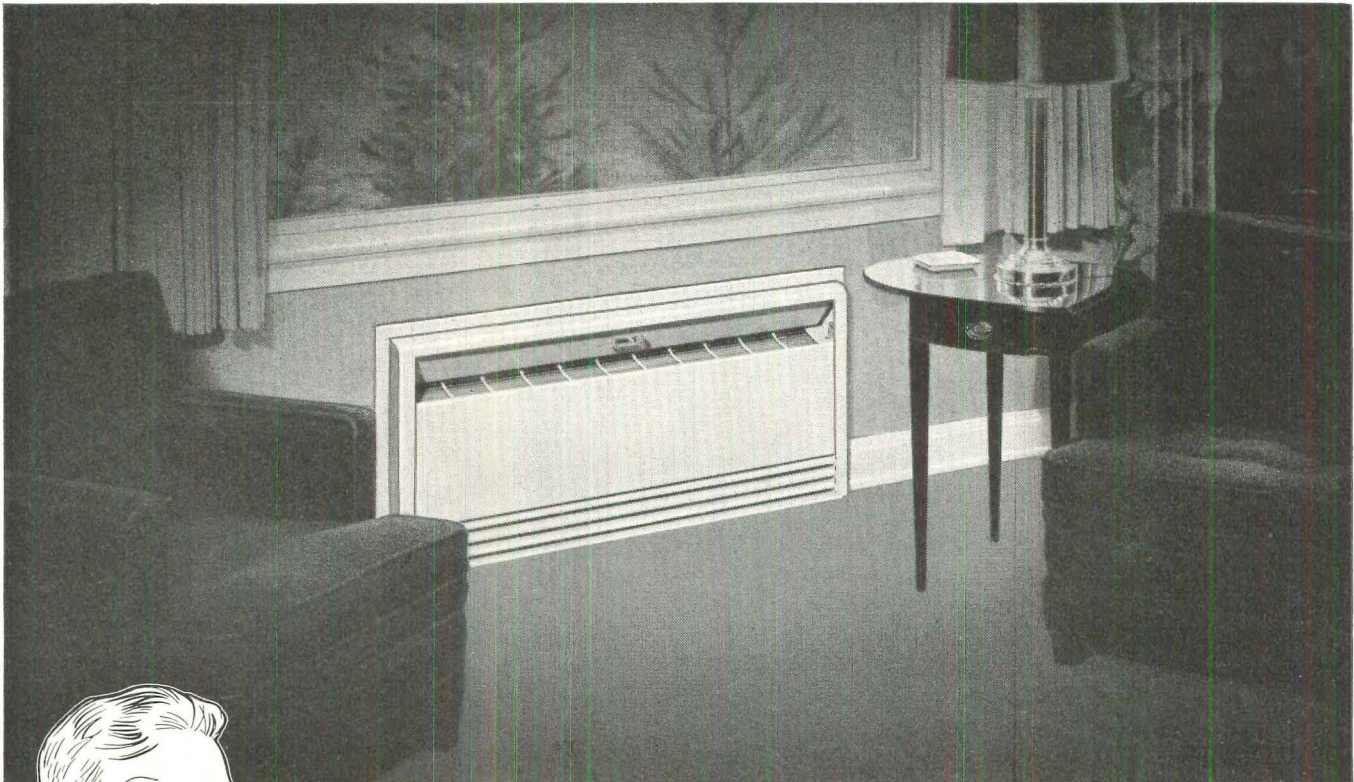

He's happy because Modine Convectors give him truly modern heating — maximum efficiency with either steam or hot water systems. He gets safe, healthful air circulation . . . uniform comfort that's based on a combination of convected and radiant heat. And he goes for the instant response to thermostatic control . . . the individual room temperature control made possible by Modine's adjustable damper.

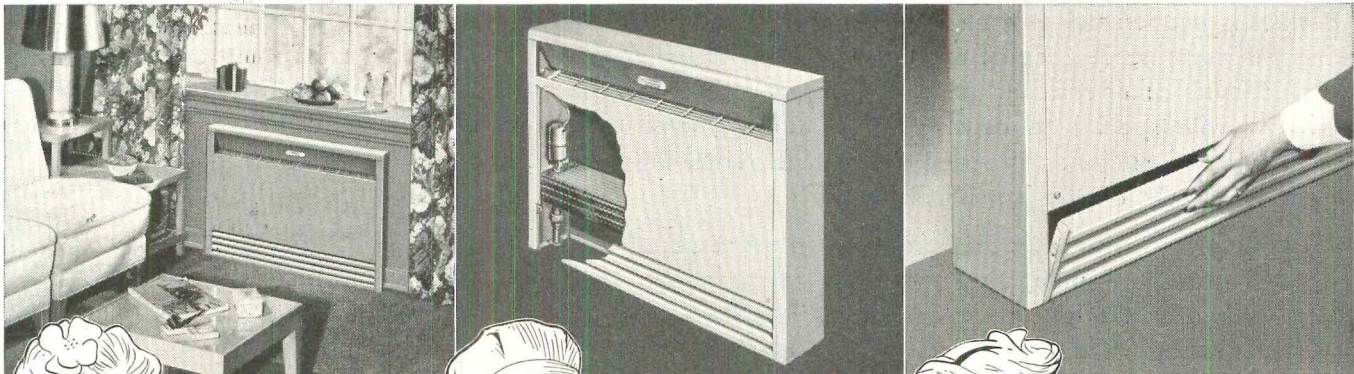

She's happy because Modine Convectors match her idea of decorative appeal. She appreciates their clean, functional lines . . . the way they can be recessed under windows for unobtrusive *beauty*, blending perfectly with any interior.



He's happy because Modine Convectors are a snap to maintain. Steel rust-protected enclosures withstand roughest treatment. High-speed, non-ferrous heating units resist corrosion . . . offer peak performance with minimum service.



She's happy because Modine Convectors are *so easy* to keep clean. Dust can't get a foothold! Snap-in lower grille instantly removable for routine cleaning. And for major sprucing up, front panel can be quickly removed.



For full information call your Modine representative — listed in your phone book classified section. Or write Modine Mfg. Co., 1507 Dekoven Ave., Racine, Wis.

Modine CONVECTOR RADIATION

**At
Home on**

PARK AVE

or

ELM STREET

**PARKAY Sets the
Pattern for Fine
Hardwood Floors
in Swank Apartments
and Modest Homes**

The luxury of Parkay ready-finished hardwood floors is not reserved for buildings of any specific type or price class. True, there are no finer hardwood floors than Parkay. Made of choice American Oak, then carefully factory finished, this flooring offers a lifetime of wear while keeping its lustre and beauty.



But Parkay is economical as well as durable and smart. While offering the wearing surface of standard flooring, its thickness permits use with other resilient materials without changing floor levels. Laid with special adhesive on any sound, smooth sub-surface, Parkay installation is fast—and, being ready-finished, it eliminates costly on-the-job finishing.

Yes, Parkay is beautiful, durable, practical — and its cost, laid and ready for traffic, is little, if any, more than conventional strip flooring finished on the job. Parkay is available in two styles — 9" x 9" Tiles and 9" wide Broadboard in random lengths. Write for free sample and complete information. Wood-Mosaic Co., Inc., Louisville 9, Ky.

PARKAY

READY-FINISHED HARDWOOD FOR FLOORS AND WALLS



PRODUCT NEWS

tions on 2½ and 1¼ in. centers, and cross crimped corrugations. Standard gauges run from .024 to .050.

Manufacturer: Philadelphia Rust Proof Co., 3225 Frankford Ave., Philadelphia 34, Pa.

MINIATURE CABLE CAR made for tired cliff dwellers.

An elevator that goes up on the bias, the Hill Climber is serving many in the plush but fatigued San Francisco set as family cable cars. Actually, the devices look very little like that city's famed slanting streetcars, but the firm's slogan is *A Private Cable Car for Every San Franciscan for \$1,500 and up.* (The "up" sometimes comes to \$5,000 for installations on long,

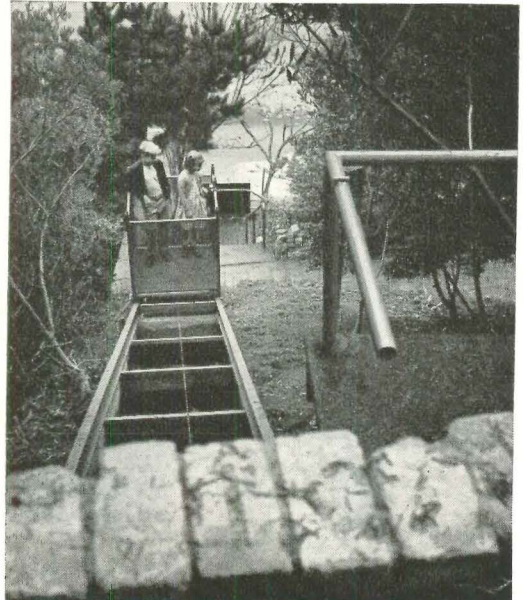

complicated runs.) Now, Hill Climbers are available throughout the country to those who have had to pay for their Olympian views by climbing countless steps with shortened breath.

Briefly, the structure consists of a lightweight carriage usually 42 in. wide, 36 in. long with perforated metal panels 36 in. high and an iron pipe railing. Framework is made of steel angles welded together in such a way that small adjustments can be made on the job to get the exact pitch. Car guides and all structural supports are steel. The ball-bearing rubber tired wheels which roll inside the guides may be adjusted without removing the car. Electric controls inside the car work through an electric cable which is played out and retrieved without being dragged over the ground during its course of travel. (A safety device prevents the cable from unraveling.) All wiring is in metal conduit and switches are weatherproof. Speed of the Hill Climber, powered by a reversible motor, is about 40 to 50 ft. per minute. Emergency devices and landing platforms are included in the job. Hill Climbers are generally painted a medium green to match surrounding foliage but can be ordered in more extravagant tones if the purchaser should so desire. *Manufacturer:* Dwan & Co., 629 Fulton St., San Francisco, Calif.

(Continued on page 216)

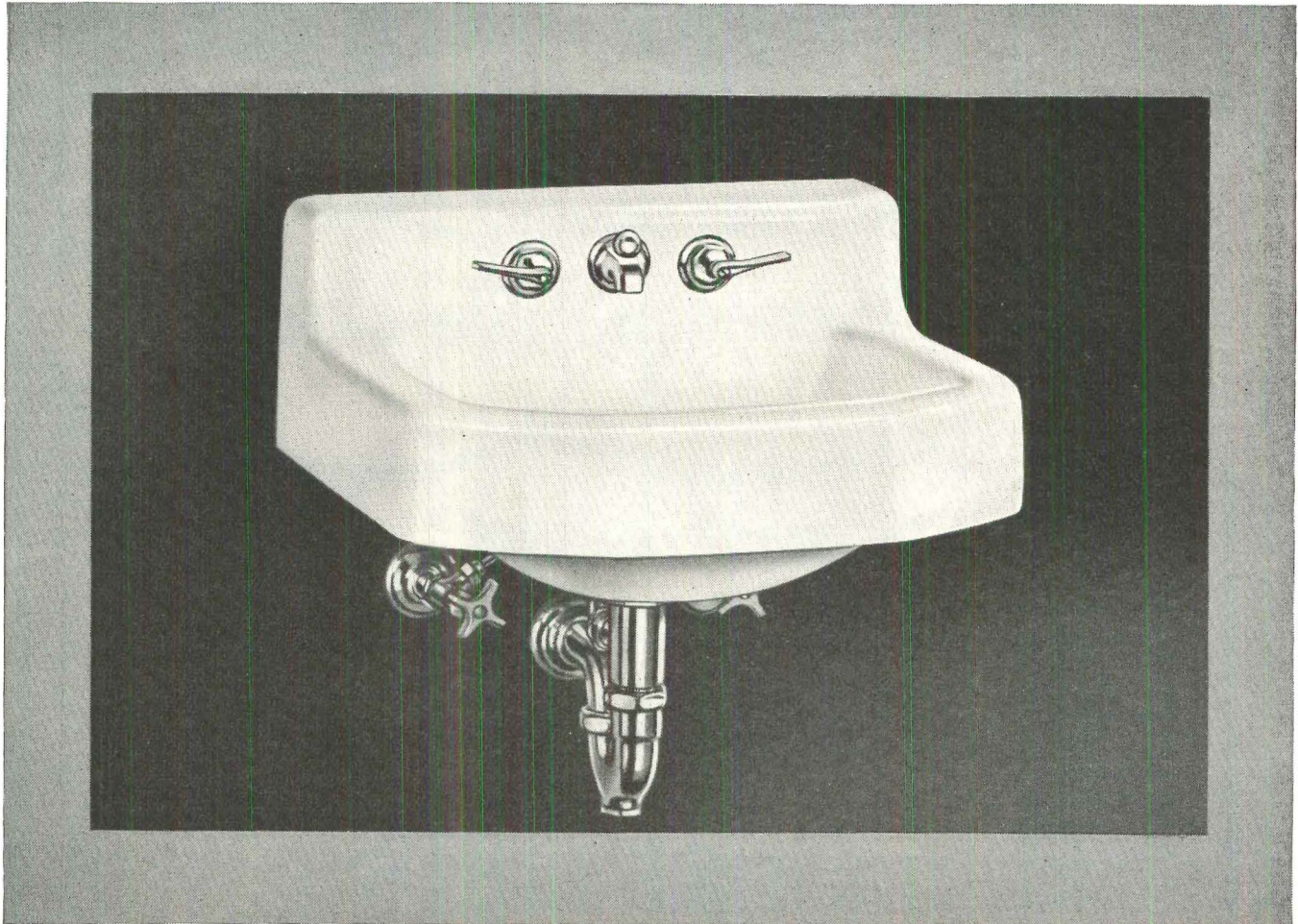

K-2700-A. 19 x 17", 22 x 19". Latter with built-in soap dishes.

HAMPTON LAVATORY

without overflow

The popular Hampton enameled iron lavatory is now available without overflow—an innovation which is receiving wide acceptance.

The Hampton is extensively used in homes and apartments. Features that appeal to home planners, architects and builders include the unobstructed shelf across the back, ample basin, compact mixer fitting with Synchro pop-up drain. The lustrous, easy-to-clean Kohler enamel is fused to non-flexing iron, cast for rigidity. Fittings are of durable brass, chromium-plated.

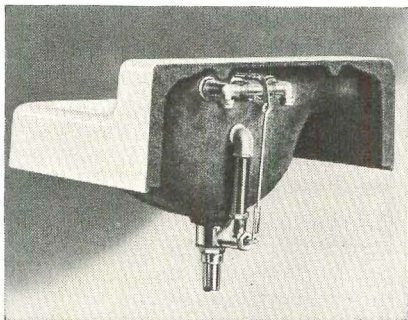

The Hampton is also offered with a brass overflow. (K-2701-A).

Kohler Co., Kohler, Wisconsin. Established 1873.

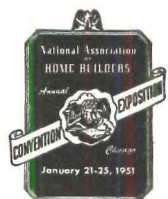

KOHLER OF KOHLER

PLUMBING FIXTURES • HEATING EQUIPMENT • ELECTRIC PLANTS • AIR-COOLED ENGINES • PRECISION PARTS

*What acoustical ceiling shall I use
for efficiency and fire-safety?*

*I'd recommend
J-M SANACOUSTIC*
a perforated metal unit*



That's the best answer to that problem.

Ideal combination of advantages makes J-M Sanacoustic
a favorite choice for institutions, offices, hospitals, schools, restaurants, etc. . . .



**J-M
SANACOUSTIC
is
NONCOMBUSTIBLE
DEMOUNTABLE
EASY-TO-CLEAN**

Baked-enamel finish is
easy to wash, easy to
maintain

THE ADVANTAGES of J-M Sanacoustic Panels include fire safety, good appearance, removability, high light-reflection, ease of maintenance, and extremely high sound-absorption qualities.

As a result, millions of square feet of Sanacoustic have been installed in institutions, offices, hospitals, schools, hotels, and other places of public assembly.

Consisting of perforated metal panels backed up with a fireproof sound-absorbing element, Sanacoustic Ceilings will not burn, rot, or disintegrate. They may be applied over new or existing construction.

An exclusive J-M patented construction system permits interchangeability of flush-type fluorescent lighting and acoustical ceiling units. Write for our brochure, "Sound Control." Johns-Manville, Box 158, Dept. MB, New York 16, N.Y.

*Reg. U. S. Pat. Off.



Johns-Manville

J-M Acoustical Materials include Sanacoustic* Units, Transite* Acoustical Panels, and drilled Fibretone*

ASBESTOS

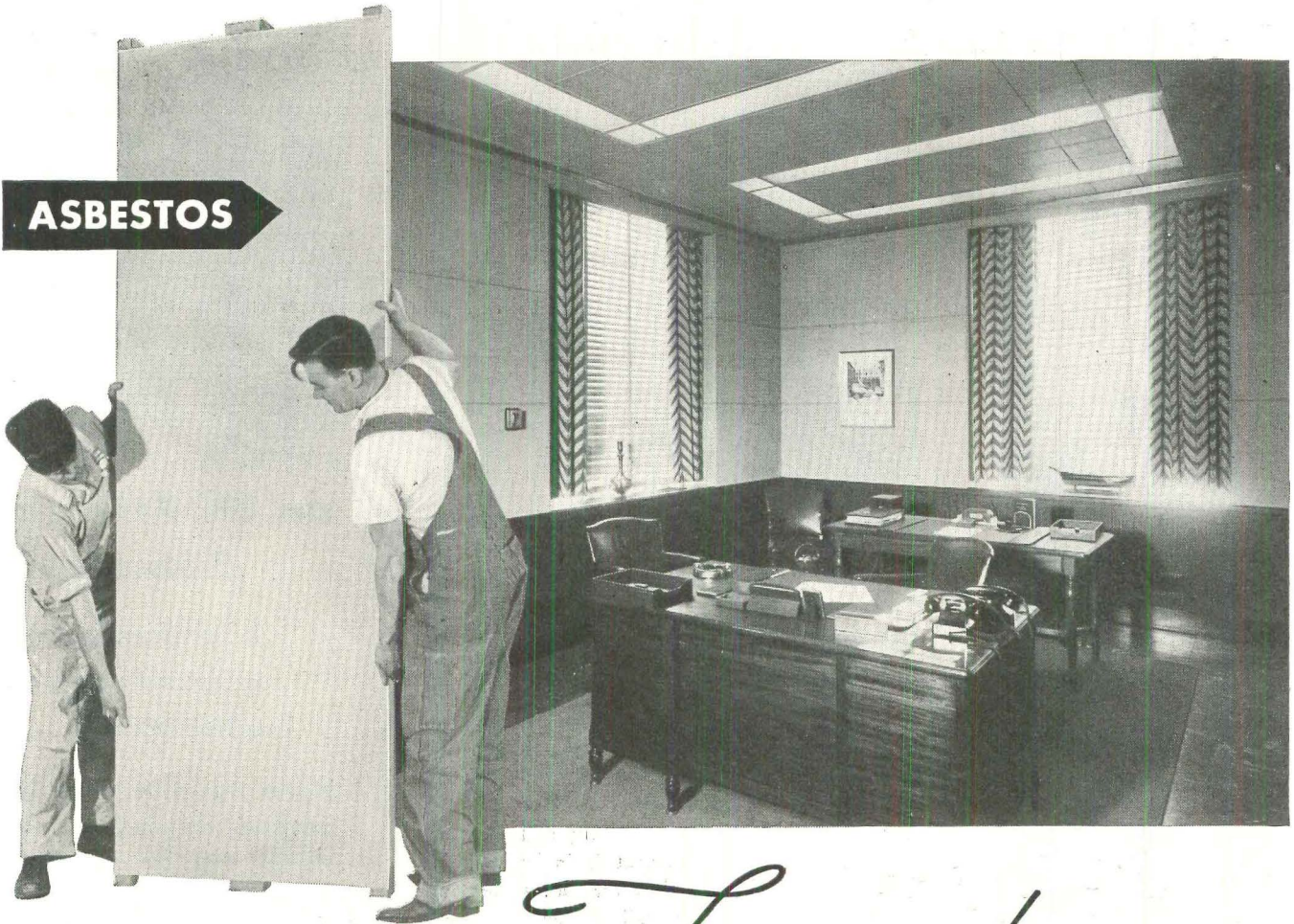

FLEXIBLE MINDS ACCLAIM THESE

Flexible Interiors

"Asbestos Movable Walls answer the problem of our changing space needs," say executives who like the idea of "rooms when and where you want them."

Today many of the most modern buildings have miles of Johns-Manville Movable Walls. Their unique appeal lies in the fact that they are made of *asbestos*: they are attractive in appearance, fire-safe, hard-to-mar, and highly resistant to shock and abuse.

J-M Asbestos Wall sections are light, easy to locate. They are erected as ceiling-high or free-standing partitions and railings, either solid or with glass. Ideal as interior finish for outside walls.

"Dry" construction insures little or no interruption to business routine. Flush asbestos walls have no dust catching projections, are easily maintained. The

complete wall, including doors and hardware, is installed by Johns-Manville construction crews—responsibility is undivided.

An estimate will convince you that the cost of J-M Asbestos Movable Walls compares favorably with that of other types of wall construction. The J-M Movable Wall line includes:

Integrally-Colored Transitone Walls—J-M Asbestos Transitone Walls eliminate the cost of periodic decorative treatment. The panels are integrally colored by blending non-fading pigments with asbestos fibre—the color goes *all the way through each panel*.

Transite® Walls—J-M Transite Walls, Imperial Type, may be left in their natural gray finish or decorated as desired. J-M Transite Walls, Universal Type, are low in cost and use no critical war materials.

• • •

For details, consult your Sweet's Architectural File, or write Johns-Manville, Box 158, Dept. MB, N. Y. 16, N. Y.

JOHNS-MANVILLE
JM
PRODUCTS

Johns-Manville Movable Walls

INSTALLED NATIONALLY BY JOHNS-MANVILLE

THE VERSATILE PENCIL OF TOMORROW

Speed Your Paper Work

WITH A WORLD-FAMED

norma

MULTIKOLOR PENCIL

4

Colors in One Quality Pencil

RED

BLACK

BLUE

GREEN

Jewelry-crafted . . . precision-engineered . . . Guaranteed for mechanical perfection . . . From \$4.50 up at all stores.

actual size

ARCHITECTS
Discover how Norma speeds your work on blue-prints, plans, sketches, etc. . . . Yellow may be substituted for any color on request . . . Write for new book, giving many professional uses for Norma Pencils; no obligation.

NORMA PENCIL CORP., AF
NORMA BUILDING
137 West 14th Street
New York 11, N. Y.

Please send me, without charge, your new attractive book showing how Norma can help speed my special daily tasks.

Name

Address

City Zone State

© Norma Pencil Corp. 1950

PRODUCT NEWS

MULTICOLOR PAINT FINISH achieved in single spray application.

No longer is polka dot paint in the sky hook class. Today, a not-so-naive painter's apprentice who is sent out for a can of multicolor paint can come back with *Plextone*. Applied by spray gun, a single coat of this lacquer forms a network of interlaced colors. Each tone retains its identity

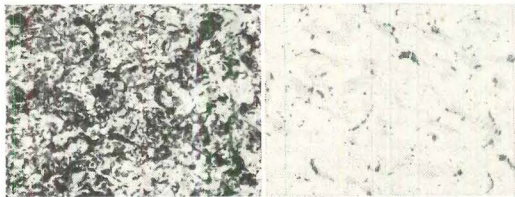

in the overall textured surface however, and the possible color combinations are unlimited. As many different shades may be used together as desired. In the can, particles of pigment remain suspended in their own globules of enamel solvent. When the particles hit the surface they flow out into a pattern (but do not run). Dominant tones and size of the pattern are regulated by the proportion of colors in the mixture and diameter of spray nozzle used. Long Island builder Alfred Levitt found that housewives living in his 1950 houses liked *Plextone's* washability and abrasion resistance. He has specified it again for his 1951 model house. The manufacturer claims *Plextone* to be very good for drywall applications since its pattern tends to conceal seams and surface imperfections. Manufactured in flat and gloss, *Plextone* can be applied over wood, metal, plaster, cement, pressed fiber board or paper. Proper primer is recommended for most surfaces. Cost to the builder ranges from \$3.75 to \$4.50 per gal., depending on quantity. A gallon covers about 100 to 175 sq. ft. Color consultant Beatrice West has coordinated 24 *Plextone* shades which may be combined in any way for interiors.

Manufacturer: Maas & Waldstein Co., 438 Riverside Ave., Newark 4, N. J.

AIR DIFFUSER is engineered for perimeter heating systems.

The neatly designed Lima Beauty floor diffuser is especially suited to perimeter heating. Measuring only 2 x 14 in., the inconspicuous grille

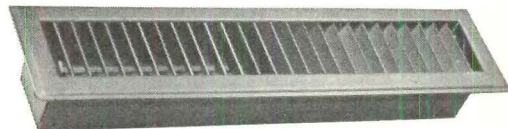

has vanes set to direct air up and out to both sides, so that warm air is sprayed over a large window area or cold wall. The homeowner can control air delivery merely by adjusting a set screw, or can shut the register completely off. The diffuser has a durable baked-on bronze finish which will blend with most floors and interior color schemes.

Manufacturer: Lima Register Co., 651 N. Baxter St., Lima, Ohio.

(Continued on page 220)



on NORTON non-slip Floors and Stairs

- Permanently non-slip
- Extremely wear-resistant
- Non-resonant

Never again need you worry about anybody slipping on floors, ramps or stairs. Positive, permanent non-slip protection—even when wet—is the guarantee you get with Norton Floors.

The extreme wear-resistance of Norton Floors to the heaviest foot traffic makes their installation an economical investment in long, trouble-free service. Also, they are quiet and comfortable to walk on.

You have four choices of Norton non-slip floor products: (1) Stair and Floor Tile, (2) Ceramic Mosaic Tile, (3) Aggregate for Terrazzo Floors and (4) Aggregate for Cement Floors.

Write for our free Catalog No. 1935 or see our Catalog in Sweet's Architectural or Engineering Files.

NORTON COMPANY

Worcester 6, Massachusetts



Making better products to make other products better

NON-SLIP FLOORS

SPENCER

The Quality Line of
HEATING BOILERS

**VERSATILE
DEPENDABLE . . .**

***Backed by more than
60 years' leadership***

There is a SPENCER for every building
... for every fuel, with capacities from
290 to 45,000 square feet, steam. Pre-
cision engineered and manufactured
to give superior, guaranteed service.

Visit our Booth No. 148

at the International Heating and
Ventilating Exposition, Commercial
Museum, Philadelphia, Pennsylvania.

JANUARY 22-26, 1951



There are two beautiful sides to this door story

Architects Ferrenz & Taylor take advantage of the great versatility of Weldwood Stay-Strate Doors

Here's one place where it pays to be two-faced.

The Weldwood® Stay-Strate Doors (with Kaylo* Core) in the Board Room of the Fitkin Memorial Hospital, in Asbury Park, New Jersey, are a beautiful example of how you can blend these versatile doors with almost any decorative scheme.

One side has the sheer, flush face that goes with the decorative motif of the entrance hall. The other, using walnut molding, has a paneled effect that blends perfectly with the traditional setting of the interior.

And... on top of decorative versatility... this modern door has many other advantages to offer.

The Weldwood Stay-Strate Door won't warp — in fact, a strong guarantee to this effect appears on every door. Here's a door that stays straight — that won't shrink or swell — not only when it's installed, but throughout its entire life!

Because it's constructed with the same incombustible mineral core material used in the famous Weldwood Fire Door... you get unusually effective fire protection. Use it in unclassified openings as the perfect complement to the Weldwood Fire Door.

In addition, the Weldwood Kaylo Core Door can be specified where you need:

- Maximum Dimensional Stability . . .
- Light Weight . . .
- Extraordinary Durability . . .
- Waterproof Bond . . .
- Suitable for both interior and exterior use . . .

Specify lights and/or louvers to your needs, and we'll cut them before shipment. Face veneers can be had in a wide variety of domestic and imported hardwoods.

United States Plywood Corporation carries the most complete line of flush doors on the market including the famous Weldwood Fire Doors, Weldwood Stay-Strate Doors, Weldwood Honeycomb Doors, Mengel Hollow-core Doors, Mengel and Algoma Lumber Core Doors, 1 3/8" and 1 3/4" with a variety of both foreign and domestic face veneers.

**T. M. Reg. U. S. Pat. Off., Owens-Illinois Glass Co.*

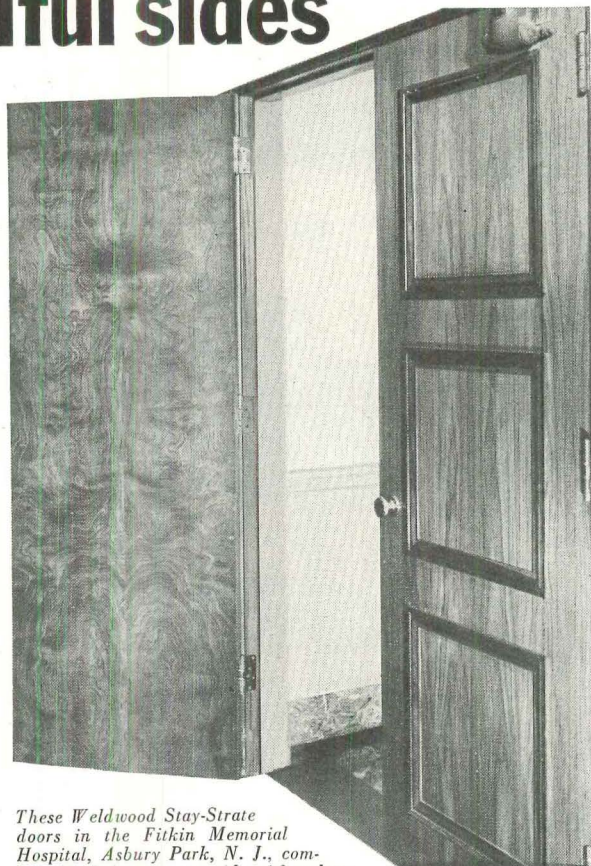

These Weldwood Stay-Strate doors in the Fitkin Memorial Hospital, Asbury Park, N. J., combine birch faces on one side with walnut faces on the other. The addition of walnut moldings was all that was necessary to give a traditional paneled effect.

ANOTHER WELDWOOD DOOR... the famous WELDWOOD FIRE DOOR with THE UNDERWRITERS' LABEL...

gives you complete fire protection at moderate cost.

Here's your opportunity to combine protection and decoration in one beautifully finished, moderately priced, wood-faced flush door.

This door carries the Underwriters' Label for Class "B" openings, and can be so used with complete assurance of approval for fire-proof construction.

Available in a wide range of sizes... up to 4 ft. wide and 7 ft. high... and in a variety of imported and domestic hardwoods... the Weldwood Fire Door has recently received Underwriters' approval to carry light openings up to 10 in. square.



WELDWOOD Flush Doors

Manufactured and distributed by

UNITED STATES PLYWOOD CORPORATION

55 West 44th Street, New York 18, N. Y.

Branches in Principal Cities • Distributing Units in Chief Trading Areas • Dealers Everywhere

it's well worth

Seeing....

The efficiency and flexibility of standard Pittsburgh Permaflector Lighting Equipment make possible made-to-order illumination at foot-candle levels required for each particular job.

There are units designed for overall fluorescent or incandescent illumination, for spotlighting and floodlighting, and for special effects and accents.

You'll be way ahead by planning your installation to utilize the full benefits of Pittsburgh Permaflector Lighting Equipment . . . and you'll see the difference!

PITTSBURGH PERMAFLECTOR LIGHTING EQUIPMENT

A PERMAFLECTOR PORTRAIT

Bettendorf's Market
Clayton, Missouri

Architect: Wischmeyer & Lorenz
Consult. Engr.: George E. Horch
Elec. Contr.: S. C. Sachs Co.

PITTSBURGH REFLECTOR COMPANY

401 OLIVER BUILDING • PITTSBURGH 22, PENNSYLVANIA

MANUFACTURERS OF FLUORESCENT & INCANDESCENT LIGHTING EQUIPMENT

Permaflector Lighting Engineers in All Principal Cities

PITTSBURGH PERMAFLECTOR LIGHTING EQUIPMENT IS DISTRIBUTED BY BETTER ELECTRICAL WHOLESALERS EVERYWHERE



WANT TO SEE MORE?

Write for the booklet "Planned Lighting For Modern Stores." It's the picture story of how to put light to work in showrooms and windows.

PRODUCT NEWS

SEPARATE GAS-BURNING COOKING UNITS allow flexibility in kitchen arrangement.

From a chef's eye view, spinach and angels' food cake have very little in common. There is no practical design reason why the surface unit used in preparing the first has to be eternally wed to the oven, incubator for the latter—except that it is usually cheaper to run in a single fuel line. The electric stove industry, alert to architects' and housewives' demands for flexible,



Chambers Corp.

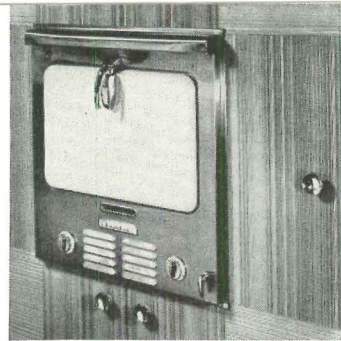

Cooking facilities may be placed to fit family needs with built-in ovens and counter top units.

Broader economic horizons are open to architects and building contractors who think of masonry in four-dimensional terms

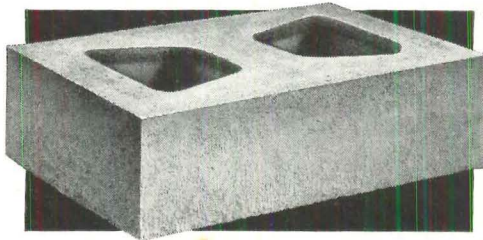

Inherent structural values . . . planned beauty . . . low cost . . . ready availability. Analyzed in these terms Brikrete qualifies as the world's most practical masonry.

In design, size, proportion, strength, weight and laying ease, Brikrete has a combination of values offered in no other masonry unit.

Modern size, symphonic proportion, true symmetry, narrower (and fewer) mortar joints, and ingrained color combine to make Brikrete externally attractive.

Brikrete is for homes or housing projects . . . for apartments or motels . . . for schools, churches and other public buildings . . . for practically all kinds of residential, commercial, and industrial construction.

Decentralized manufacturing in self-contained local plants makes it possible to convert local aggregates into attractive masonry units for local or nearby consumption.

Two of the biggest costs ordinarily present—freight and distribution—are eliminated. Savings are sufficient to effect drastic price reductions without sacrifice of basic quality.

A chain of several hundred independently owned local plants assures a ready supply of Brikrete in almost every section. Standardized equipment and manufacturing procedures aim to insure product uniformity.

We will cooperate in the short-haul procurement of Brikrete for any size of building or project . . . or for the establishing of plant equipment for job-site manufacturing. Write or telephone for factual information.

BRIKRETE ASSOCIATES, INC.
4681 Division Avenue S., Grand Rapids 8, Mich.

Brikrete Highlights

Face area (laid up) 12" x 3 1/2". Two thicknesses: 8" and 4", providing for "solid" or cavity-type construction.

"Buttressed Web" design (patents pending) put extra strength at points of greatest stress.

Half the net weight of ordinary brick.

Cellular formation giving self-contained insulation values. Voids range up to 45%.

Impregnated color and water-proofing. Range of ten standard colors and six pastel shades.

"decentralized" cooking facilities and waist-high appliances have been making built-in cooking units for many months. Two of the companies are Universal (Select-A-Range) and Thermador. Not to be outdone, gas range manufacturers are now introducing similar individual cooking units.

First to roll off an assembly line are those of the Chambers Corp. Its new line consists of a drop-in surface unit with three burners and an oven which may be built into the wall or set on top of a base cabinet—wherever convenient for the consumer. Both operate on piped or bottled gas, and are approved by the American Gas Assn. for placement next to combustible materials. Like the ovens in the firm's regular model ranges, the unit ovens will "cook with the gas turned off" on heat retained by a thick lining of insulation. A grooved pan for broiling foods inside the oven is part of the unit's standard equipment as is its cast iron door with plunger type lock. Finished in stainless steel, the oven retails for \$249.50; in stainless with a porcelain enamel door in any of seven colors (which the housewife may change for about \$7 to suit an altered decorative scheme) for \$244.50; and in porcelain enamel for \$224.50. The chrome plated steel cooking top section may be placed in a cabinet with a minimum length of 42 in. and a depth of 22 in. by cutting an opening 17 7/8 x 32 15/16 in. Pilot lights on each of the three daisy type cast iron burners produce a simmer or warming heat. Retail price for this unit is \$124.50. All vital parts are guaranteed for 25 years.

Scheduled for January production, Western Holly's built-in stainless steel range and combination oven-broiler will boast a CP (Certified Performance) tag for its deluxe features. Each of the four 12,000 Btu burners on the counter unit is covered with a flat steel disc for even heat distribution and easy cleaning. The surface unit measures 18 x 42 in. and is 9 in. deep. It will sell for about \$290. Not only are the top burners lit by automatic gas pilots but the oven and broiler have an electric ignitor to assure a con-

(Continued on page 224)

Western Stove Co.



with your help...

1 PLUS 1 COULD EQUAL 3

This year 150,000,000 Americans may not be enough for the job ahead—unless each of us can find some way to multiply his work and service.

In this national emergency, where manpower will soon be the greatest shortage of all, you planners and makers of buildings have a special opportunity to use your skills as a substitute for numbers.

Some of you can design factories that will produce more goods with half as many workers; some of you can put up warehouses that will move and store materials with the help of fewer hands. Some can plan hospitals in which one nurse does the work of two; build model towns to bring labor to dispersion areas which now have none.

And all of you can depend on us to help in every possible way . . . by reporting the new techniques that will help you save scarce materials . . . the design ideas that will help you save man-hours . . . the **better, faster, cheaper** methods for making buildings do the work of men.

We will measure every building we publish against its usefulness for this task. And we will welcome the problems you send us as our opportunity to marshal the industry's thinking in your behalf.

For it's your job to help the nation build its strength. It is our job to help you.

ARCHITECTURAL FORUM
THE MAGAZINE OF

Building



GEORGE R. PAUL, *Architect*

Plan a "disappearing act" for telephone wires

Hidden telephone wiring helps protect the beauty of carefully planned interiors. It helps, too, in selling quality-conscious prospects. For telephone raceways are a sign of thorough planning and thoughtful construction.

It's easy and inexpensive to build in telephone raceways. First, select convenient locations for telephone outlets. Then, during construction, have a few lengths of rigid or flexible conduit placed inside the walls and connected to the outlets. These provide "hidden passages" for wires when telephones are installed later on.

Your Bell Telephone Company will be glad to help you. Just call the local Business Office for assistance in planning telephone service in the homes you build.

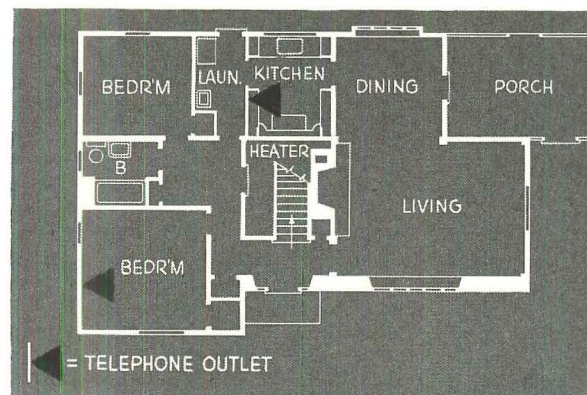

BELL TELEPHONE SYSTEM



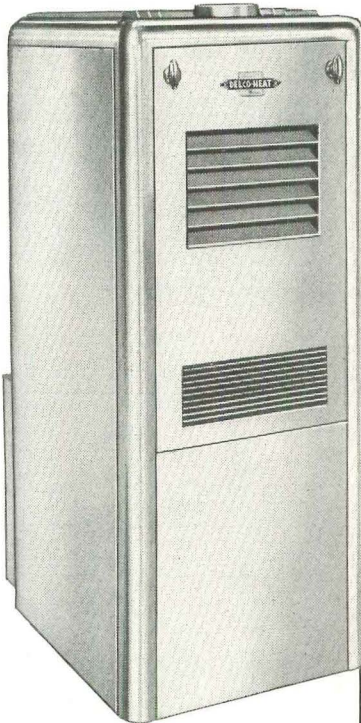

DELCO-HEAT Units

give home buyers the value, dependability and features they want

Check the specifications of these outstanding General Motors products!

"GA" series Gas-fired Conditionairs. These forced warm air furnaces feature multi-section heat transfer systems, with electrically welded *Multi-Rad* radiators that completely enclose the flames of double ribbon-type burners . . . insuring the extraction of maximum heat from the fuel. Delco *Rigidframe* motors on blowers. AGA-approved for all gases and for high altitude installations.

Model (Available with either 12 or 16 gauge heat exchangers)	Dimensions			Blower		AGA-Approved Ratings Btu per Hour (in thousands)			
	Height Inches	Width Inches	Depth Inches	RPM	CFM Max.	Nat., Mfg., Mixed or LP-Air Gas		LP-Gas	
						Input	Output	Input	Output
GA 63	55	22	26	550	550	62.5	50	60	48
GA 90	55	22	26	650	800	90	72	90	72
GA 120	55	28½	26	660	1050	120	96	120	96
GA 150	55	35	26	620	1300	150	120	150	120
GA 210	55	48	26	600	1600	210	168	210	168

"S" series Steel Oil-fired Boilers. Here are the perfect units for radiant heating systems in small homes—and for conventional steam and hot water systems, too. Have famous Delco-Heat

pressure atomizing burner, powered by *Rigidframe* motor. Provide year-round hot water for household use. Available in both de luxe and round-jacket models. Also larger capacity, cast iron boilers.

	Capacity			Oil Burner Nozzle GPH	Dimensions		
	Btu per Hour Output	E. D. R.	Net		Round Jacket	Height Inches	Width Inches
Steam Hot Water	95,200	396	300	1.0	49½	24½	37¾
	95,200	635	480	1.0	Deluxe Cabinet	49	24

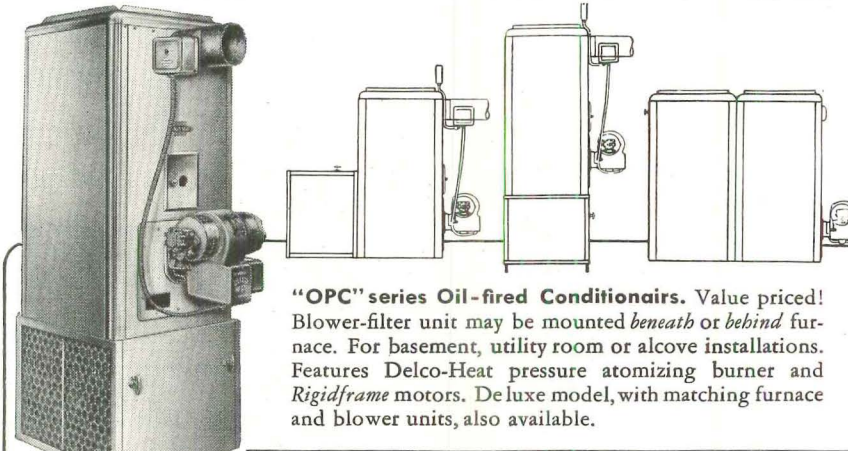
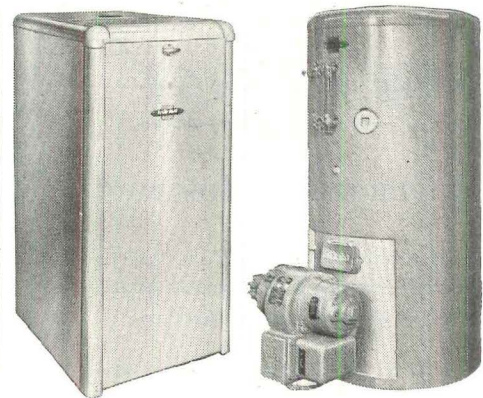

"OPC" series Oil-fired Conditionairs. Value priced! Blower-filter unit may be mounted *beneath* or *behind* furnace. For basement, utility room or alcove installations. Features Delco-Heat pressure atomizing burner and *Rigidframe* motors. De luxe model, with matching furnace and blower units, also available.

Capacity Btu per Hour Output* (Plenum)	Firing Rate GPH	Blower				Filter Size Inches
		RPM	CFM Max.	Motor		
				HP	Watts†	
75,000	¾	400-700	800	¼	385	20 x 25 x 1

*On basement installations add 15% duct loss to net heat loss—compensate for unusual conditions.
†Maximum watts allowable on motor.

New homes sell better when they're equipped with Delco-Heat!

Delco-Heat manufactures a complete line of automatic home heating products—for all fuels, all heating systems, and all sizes of homes. And our engineering and sales departments will be glad to serve you in any way possible. Also manufacturers of electric water systems for domestic water supply. For information about Delco-Heat products, write to Delco Appliance Division, Dept. MB-20 General Motors Corporation, Rochester 1, New York.



Budget Wise Housing
with a *Custom Look*

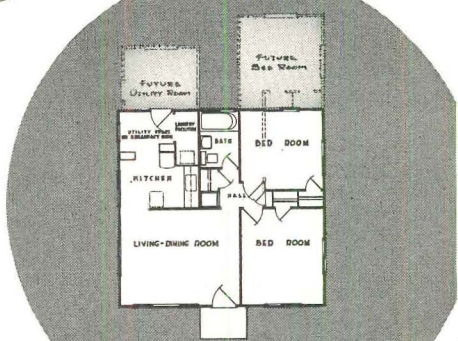

New for '51

26' 6" x 24' 6"

The Long Island

Home by General Industries

**Priced to sell under Regulation "X",
Package complete including wiring,
More profit from quick turnover.**

GENERAL INDUSTRIES HOMES are acclaimed unique for their "conventional appearance both inside and out." Dealers tell us the Storage Attic, AIRadiant heating and other exclusive features are very popular with buyers. Hundreds of homes have been built and sold over a period of years, under FHA and VA regulations with financing through the world's largest institutional lenders.

The most completely factory fabricated home on the market . . . doors, windows and storm doors are hung, woodwork is prefinished, wiring is complete with switches and plugs installed and walls are ready for the decorator. Because everything except the plumbing is delivered to the site, your supply problems are solved. The homes are erected, roofed and locked the first day.

General Industries, Inc., Builder-Dealer franchises are open to reputable organizations within 300-400 miles of Fort Wayne. Write 3031 Wayne Trace for details.

**A Complete Finance Plan
Both interim and permanent**

BUILD 'EM IN A SINGLE DAY

GENERAL INDUSTRIES, Inc.



FORT WAYNE, INDIANA

PRODUCT NEWS

stant flame. Priced at \$180, the oven has a port-hole and is porcelain enameled on the inside. It is 23½ in. from front to back, 21½ in. wide and 40 in. high. Griddle and counter units with two, six and eight burners are also planned for production.

Manufacturers: Chambers Corp., Shelbyville, Ind.; Western Stove Co., Inc., Culver City, Calif.

TRANSPARENT COATING protects building from water damage.

A clear liquid compound, Lipton All-Seal Waterproofing penetrates construction materials and seals them against erosive effects of water. The coating may be brushed or sprayed on all kinds of masonry, shingle roofs, natural woods and even canvas and sailcloth. Transparent, it leaves no stain nor will it change the colors or texture appearance of materials to which it is applied. Coverage is from 200 to 350 sq. ft. per gal. By retarding the penetration of water-borne soil, All-Seal helps keep exterior surfaces clean. It is also claimed to discourage termites, dry rot and

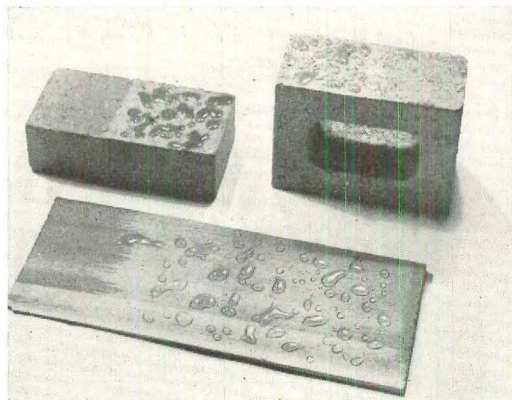

condensation. On the materials pictured above, treated sections do not absorb the water poured on them, while water has soaked into the untreated surfaces. Price for the coating is about \$5.25 per gal.

Manufacturer: Progressive Enterprises, 1001 N. Vermont Ave., Los Angeles 27, Calif.

PLASTIC STRIP prevents water seepage between bathtub edge and walls.

Household trouble spots—edges around bathtubs, sinks and showers—may be waterproofed easily with a new plastic sealing strip. Packaged in the Tub Corner Cove Kit is a 15 ft. length of high gloss white plastic tape, waterproof adhesive, a brush applicator and cleaning fluid. Approximate price is \$2.

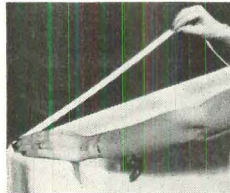

Manufacturer: Yardley Plastics Co., Columbus 15, Ohio.

LIQUID STAINLESS STEEL applied like paint.

A pale gray coating of 18/8 stainless steel now can be brushed or sprayed on almost any surface. Packed in a regular paint can, Liquid Stainless
(Continued on page 230)

REZNOR

*world's largest selling
gas unit heater*

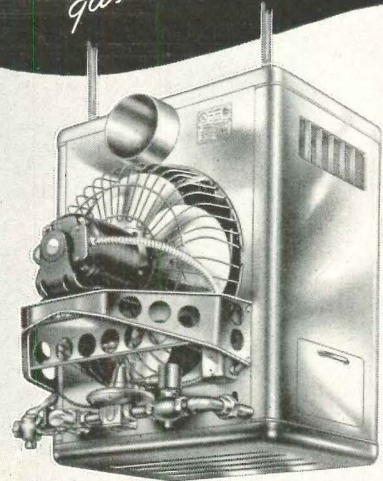

Hung from ceiling
or mounted on floor



**CLEAN,
QUICK,
AMPLE HEAT**

all winter long
... automatically delivered

Contrast central heating plants with Reznor unit heaters . . . no pipes, no heat waste through travel to point of use. No overheating of large or small areas. Heat is manufactured at point of use. We have a dealer near you.

REZNOR MANUFACTURING CO.
20 UNION ST. · MERCER, PENNA.

Send me 20-page catalog in full color

Name _____

Firm _____

Address _____

City _____ Zone _____ State _____

**STRAN
STEEL**

QUONSETS

provide valuable space, quickly and at low cost, as

FACTORIES • WAREHOUSES • MACHINE SHOPS • STORAGE BUILDINGS

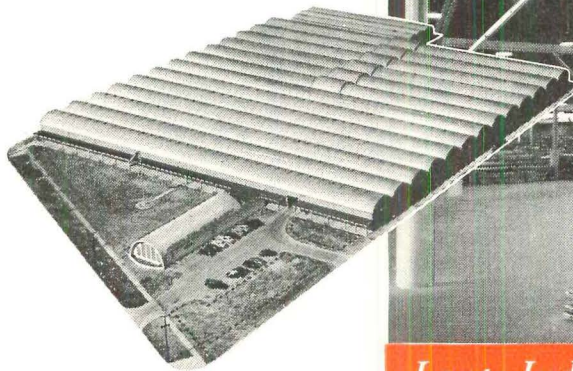

Large Industrial Warehouse ... 5 Acres for Storage

Proof of the usable floor space Quonsets provide—quickly—for industrial needs is this interior view of National Steel Products Company's new Houston warehouse. It covers five acres (see inset picture).

ALL-STEEL Quonset buildings offer the ideal solution to America's fast-growing need for quick, economical construction.

For large industrial installations or small, Quonsets give you a variety of sizes . . . in a variety of lengths . . . superior fire-protection . . . lasting durability.

The amazing versatility of Quonsets was first shown in World War II . . . after V-J Day their fast erection and economy of material helped speed the nation's quick return to peacetime prosperity.

Now, more than ever, new and improved Quonsets are your best bet for all-round speedy construction. For full details, see your nearby Quonset dealer, or write direct to—

Built in 12 Weeks...

at Half the Cost!

Archie Furr, Lincoln, Neb., wholesaler, needed a new warehouse and office *fast*, at an economical figure. His multiple Quonset was completed for half the amount bid on conventional type building.



To Supplement Existing Structures ... Quickly!

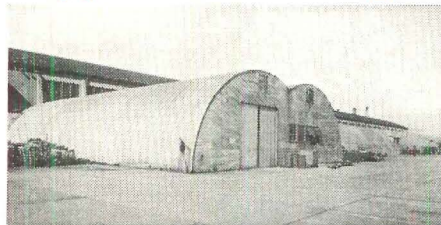

Quonset Multiple and Quonset 40 were chosen by Twin Coach Co., Buffalo, N.Y., to provide additional storage space and experimental manufacturing facilities. Flexibility of design and speedy construction make Quonsets ideal for factory additions.

GREAT LAKES STEEL CORPORATION
Stran-Steel Division • Ecorse, Detroit 29, Michigan

PRODUCER OF



NATIONAL STEEL CORPORATION



STRAN-STEEL AND QUONSET
REG. U.S. PAT. OFF.

DELFAIR
QUALITY LUMBER

OAKBLOK

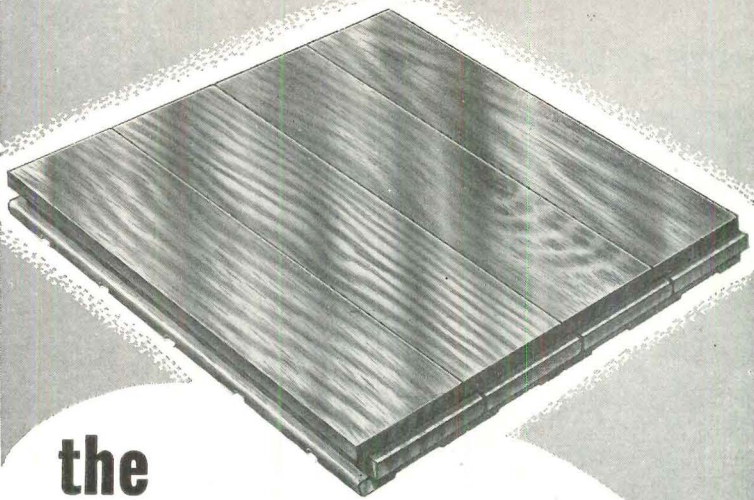

the
name to
remember in flooring

Another quality Delfair flooring product is now ready for builders everywhere—new distinctive Delfair OAKBLOK.

Available either unfinished or prefinished, Delfair OAKBLOK brings extra beauty and durability to any home or commercial building. Easy to install—either in mastic or by nailing—and surprisingly low in cost. Sizes for every job—6¾", 9" and 11¼".

Specify Delfair OAKBLOK today . . . flooring which is sure to win the praise of both homeowners and builders everywhere.

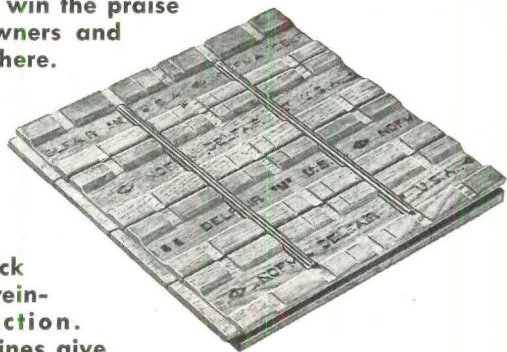

BACK VIEW of Delfair unit block shows sturdy, reinforced construction. Two built-in splines give extra ruggedness and durability. In addition to these splines, each block features five cross-wise grooves spaced to insure complete rigidity when laid in mastic. With Delfair OAKBLOK you get hardwood floors of lasting beauty and superior strength.

D. L. FAIR LUMBER CO.
LOUISVILLE, MISSISSIPPI

DELFAIR QUALITY FLOORING PRODUCTS:
Standard Strip • Prefinished • Oakblok
Plank • Square Edge Strip

MEMBER
NOFMA

**ELEVATOR
SELECTION
MADE
EASIER**

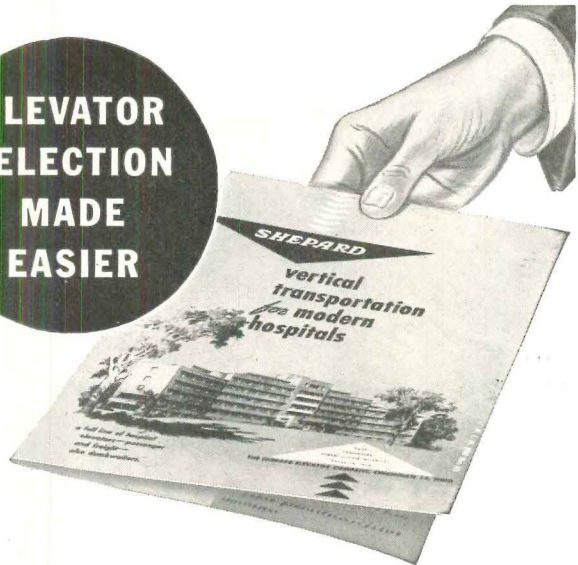

Here's "what you should look for" elevator information for all architects.

**DO
YOU
HAVE . . .**

"Elevator and Dumbwaiter Planning"—complete selection and standards information in a new 58 page booklet.

"Vertical Transportation For Modern Hospitals"—specific features which should be incorporated in hospital elevator planning.

"Shepard RAM LIFTS"—low-first cost, low operating cost oil hydraulic lifts for four floors or less.

WRITE FOR YOUR COPIES TODAY

SHEPARD ELEVATOR COMPANY
2440 A1 COLERAIN AVENUE CINCINNATI 14, OHIO

insulated comfort



BILDRITE* sheathing

Gives you more than twice the insulating value and bracing strength of horizontal wood sheathing. Specify 4' Bildrite Sheathing with confidence.



Made of Hardy

Northern Wood

*® 1

INSULITE DIVISION, MINNESOTA AND ONTARIO PAPER COMPANY

One of many full color illustrations in *The Color Book Of Tile*. See color schemes, alternate patterns, bathroom accessories, inserts, decorative tiles.

NOW
it's **EASY**
to
Specify
Tile



SEE it... in
COLOR

IN THE **NEW** COLOR BOOK OF

TILE

Here now, ready for big and little home planning, are complete bathroom, kitchen, and game room installations in American-Olean's Color Book of Tile. Here are full color illustrations in easy-to-use form. Tile selections of all kinds are conveniently arranged... offer side-by-side comparison of alternate color and pattern choices.

American-Olean's Color Book of Tile lets your clients visualize the finished installation... lets you plan it by simply copying a 42 word specification (you can choose colors later)... helps the tile contractor satisfy you and your client with exact follow-through of your specifications. Use The Color Book of Tile for every job. See how easy, how time saving, how sure, specifying tile can be.

American-Olean Tile Company
Executive Offices
900 Kenilworth Ave., Lansdale, Pennsylvania

Free TO EVERY ARCHITECT

American-Olean Color Book of Tile

The most complete, most helpful tile book ever produced. 100 pages, including 30 full color plates of typical installations, also color charts of wall and floor tile, trim, and hand-decorated inserts. Full architectural data and ready-to-use specifications. If you do not have a copy, or if you need another, write us at once.

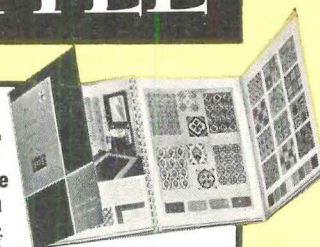

IT'S REAL CLAY TILE



make it a
**One-Piece
 Pipe Line**

with SILBRAZ* joints

Silbraz joints, made with Walseal* valves, fittings and flanges, actually make a "one-piece pipe line" of brass, copper, or copper-nickel I.P.S. pipe or tubing . . . leaky joints are completely eliminated, and maintenance costs are reduced to the minimum.

A Silbraz joint is *silver-brazed* — not soldered. This modern pipe joint will not creep or pull apart under any condition which the pipe itself can

withstand . . . vibration or corrosion will not affect it. A Silbraz joint is designed to have a tensile strength equal to about three times standard weight brass pipe, and the pipe will fail before the joint will pull apart.

For full information about Silbraz joints made with Walseal valves, fittings and flanges, see your nearby Walworth distributor, or write for Circular 84.

*Patented — Reg. U. S. Patent Office



Make it a "one-piece pipe line" with Walseal



WALWORTH
valves and fittings

60 EAST 42nd STREET

NEW YORK 17, N. Y.



Solve your space problem with flexible interiors

... this Book of Facts tells you how

● This easy-to-read booklet is full of practical facts that will show you how to make your building interiors more useful, efficient and attractive—at less cost—with Mills Movable Metal Walls.

It is based upon more than thirty years experience in the design and manufacture of flexible interiors by The Mills Company.

The exclusive construction features shown in this book have made Mills Movable Metal Walls recognized as the demonstrably superior system for flexible division of interior space in offices, factories, schools, hospitals, commercial, industrial and institutional buildings of every type.

THE MILLS COMPANY, 976 WAYSIDE ROAD, CLEVELAND 10, OHIO

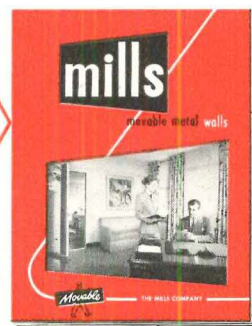

A PRACTICAL BOOK for BUILDING PROFESSIONALS

We'll be glad to send you a free copy of this 48-page book. Just ask for Mills Movable Metal Walls Catalog No. 51.



You'll also find this catalog in Sweet's File, Architectural, for 1951.



SPECIFY THE
Sedgwick
ROTO-WAITER

for { SAFE
DEPENDABLE
ECONOMICAL

**TWO-STOP ELECTRIC
DUMB WAITER SERVICE**

**Fully Automatic
Roto-Waiters . . .**

- 1 Never overtravel
- 2 Are completely factory assembled and tested
- 3 Operate automatically, safely with push-button control and doors interlocked
- 4 Require only minimum clearances
- 5 Have an overload safety device for safe operation
- 6 Cut costs with simplified motor and control equipment
- 7 Require no heavy load-bearing supports, except at bottom
- 8 Are easy to install

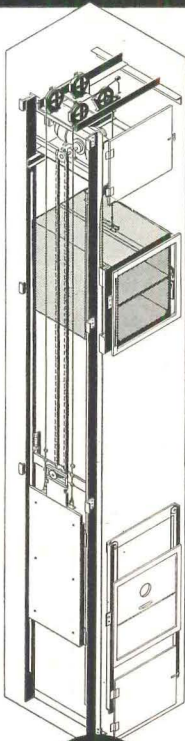

Available
in Standard
and Special
Sizes

**COMPLETE SEDGWICK LINE
MEETS EVERY REQUIREMENT**

In addition to the Sedgwick Roto-Waiter, Sedgwick also builds Multi-Stop Electric Traction Dumb Waiters for three or more landings—with a wide selection of specially engineered control equipment and signal systems to suit individual needs. Other Sedgwick Dumb Waiters—including both electrically and manually operated types—are likewise available in a wide range of sizes and capacities. Specify, too, Sedgwick Steel Dumb Waiter Doors for complete satisfaction.

Write for Illustrated Booklet AF7

Sedgwick MACHINE WORKS
88 Eighth Ave., New York 11, N. Y.

ELEVATORS · DUMB WAITERS · RESIDENCE ELEVATORS
STAIR-TRAVELERS · ROTO-WAITERS · SIDEWALK ELEVATORS
FREIGHT ELEVATORS · DUMB WAITER DOORS

**THE MAXIMUM IN SAFETY . . .
THE ULTIMATE IN ECONOMY — SINCE 1893**

PRODUCT NEWS

Steel consists of microscopic particles of stainless steel suspended in a quick drying vinyl solvent. As the coating dries (in about five minutes) the flakes overlap to form an almost continuous metallic surface which is rustproof, waterproof and extremely durable. Some applications suggested by the manufacturer are: ventilating ducts, fire escapes, water tanks, window frames, structural steel work, or any building material subjected to severe corrosive conditions. Liquid Stainless is said to adhere well to both wood and metal. Retail price is about \$12 per gal. *Manufacturer: The Lockrey Co., Plastics Div., College Point, N. Y.*

LIQUID PLASTIC seals seams on vinyl wall covering almost invisibly.

A new colorless plastic liquid permanently seals vinyl wall fabric seams. Introduced by Pantasote, manufacturers of Lifewall plastic wall material, the sealer minimizes unsightly seams and makes them waterproof. The bond created is said to be as strong as the wall covering material itself. Because water penetration at the seams is prevented, plastic wall fabrics may be used more widely in bathrooms and kitchens. The liquid is packaged in 4 oz. jars which sell for 75 cents.

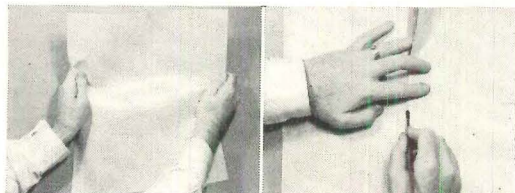

It should be applied sparingly with a fine camel's hair brush. Lifewall plastic material comes in 50 in. widths and is made in 20 colors. It has a paper backing and so can be applied according to standard paper hanging techniques. Cost to builders is about 20 cents per sq. ft.

Manufacturer: Pantasote Co., Passaic, N. J.

SLIDE RULE DEVICE simplifies estimating of metal rod and flat stock requirements.

Quantities of metal rod and flat stock needed for a construction job can be figured directly from blueprints with this new calculator. In a single setting the 2 x 11 in. slide rule device computes information needed for rod and flat stock in various metals, shapes, sizes and lengths. Estimates for rod stock with diameters of 1/8 to 3 in. may be read directly from the rule; larger rods are determined by multiplication. The instrument is priced at \$9.50. It is made of vinyl plastic, said to be oil and ink resistant and to have exceptional dimensional stability.

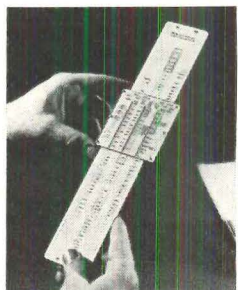

Manufacturer: H. R. Potter, Box 318, Montclair, N. J.

(Technical Literature, page 236)

**PREVENT
EXPENSIVE
WATER
DAMAGE**

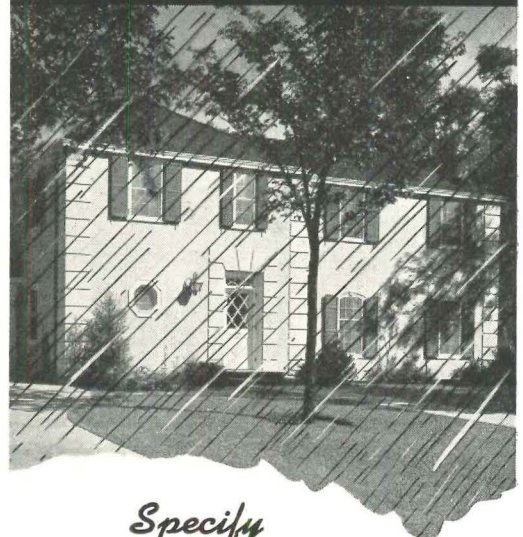

Specify

**CABOT'S
WATERPROOFINGS**

to protect exterior masonry surfaces from unsightly efflorescence and the expensive damage caused by water seepage followed by freezing and thawing. Cabot's Waterproofings penetrate deep into voids and pores of masonry walls . . . provide a long lasting moisture resistant seal. Walls treated as much as twenty years ago with Cabot's Waterproofings are still moisture-proof today.

USE CABOT'S CLEAR CEMENT WATER-PROOFING for Cement, Stucco, Cast Stone and all light colored masonry.

USE CABOT'S CLEAR BRICK WATER-PROOFING for Red Brick and Dark Colored Masonry.

Write today for samples of Cabot's Waterproofings and complete information.

Samuel Cabot, Inc.

130 OLIVER BUILDING
BOSTON 9, MASS.

Wrap your troubles in

ULTRALITE

DUCT INSULATION and DUCT LINER

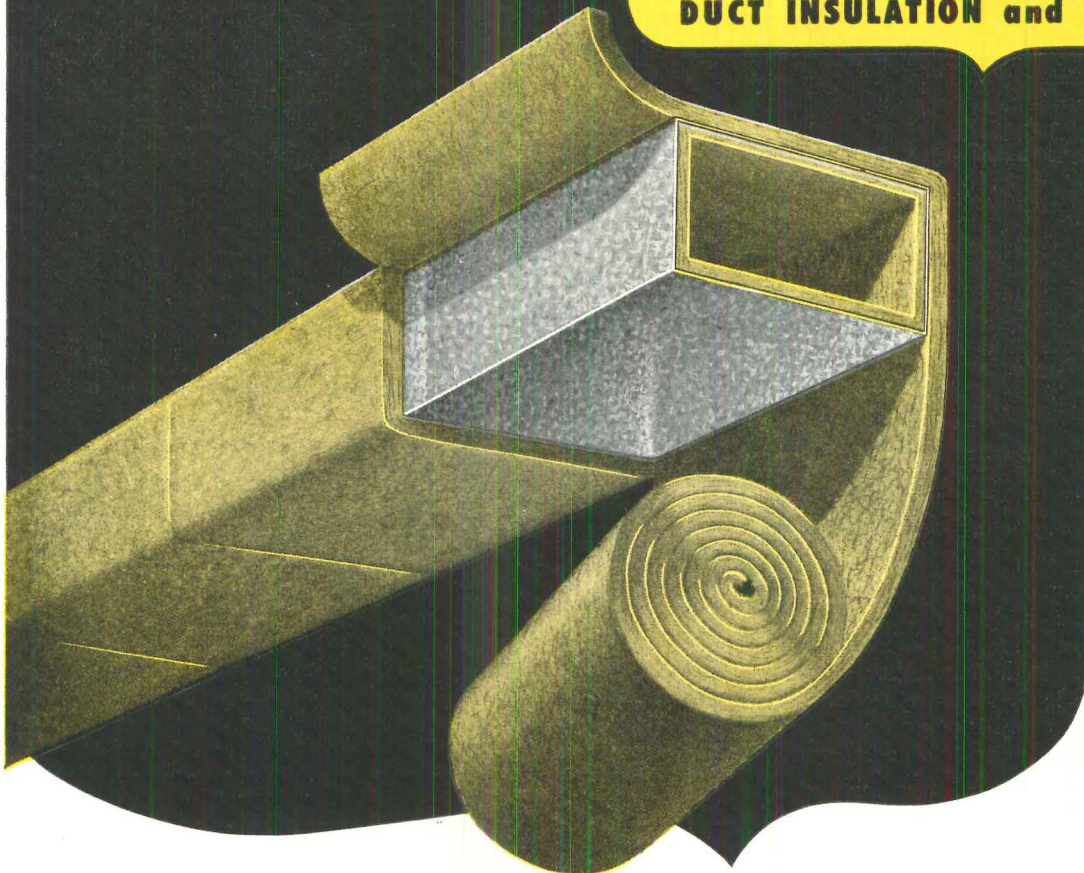

and deliver better jobs... faster... cheaper!

Just *once*, try Ultralite, the long glass fiber insulation—and you'll never use any other insulation! For Ultralite goes on *faster, easier, cheaper* . . . and it does a better job of deadening sound and keeping heat and cold where they belong.

No need to handle Ultralite with kid gloves, for it's tough, resilient — won't break, flake, chip or dent. You can cut it readily with a knife, wrap ducts as you would a package. You can run it quickly around curves and corners. You can fasten it in place with wires or metal screws and washers or cement. And Gustin-Bacon offers *six different vapor barrier facings*, one of which is tailor-made

for your particular condensation problem.

The superior thermal and acoustical properties of Ultralite in various thicknesses and densities are readily apparent from the charts in A.I.A. file No. 37-D-2. You'll like, too, the physical properties of Ultralite. The long glass fibers are fire-resistant, non-corrosive, non-irritating and as permanent as glass itself. Ultralite will not settle, shake loose, delaminate or disintegrate under air movement or vibration, nor will it pick up odors. Try Ultralite in your shop . . . soon!

For free samples and A.I.A. file No. 37-D-2, WRITE TODAY!

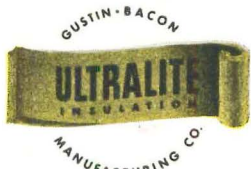

GUSTIN-BACON MFG. CO.

1412 WEST 12TH ST., KANSAS CITY, MO.

New York Chicago Philadelphia San Francisco Los Angeles
Houston Tulsa Ft. Worth

Please send me samples of Ultralite and A.I.A. file 37-D-2. Dept. AF-1

NAME _____

COMPANY _____

ADDRESS _____

CITY _____ STATE _____

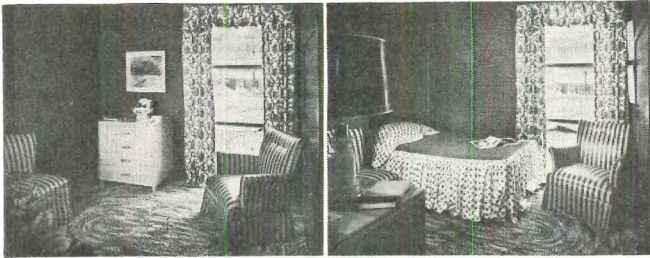

Living space by day, slumber luxury at night, feature of Norwood Home

Murphy Beds Speed Home Sales!

5 rooms become 7 in four, sensational, new small-home projects! Murphy Bed featured in all-purpose room!



The Norwood Home: Erwin Gerber, Architect; A. Sam Gittlin, Developer; Stallford Realty Co., Sales Agents; Stallford Mortgage Co., Financing.

The four New Jersey developments offering the Norwood Home will total approximately 600 units. This fast-selling, FHA, VA approved house, pictured above and subject of a feature article in the November issue of THE MAGAZINE OF BUILDING, features a recess type Murphy Bed. This particular bed is one of several Murphy Models that builders from coast to coast are finding to be the answer to the required "extra" room.

The floor plan at right illustrates the ingenuity of Norwood Home designers.

This is only one of many efficient layouts possible with Murphy Beds.

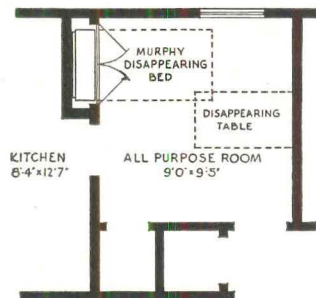

Although they require a minimum of space, all Murphy Beds are built to receive standard mattresses for maximum sleeping comfort.

Available models include new types that require as little as 13" depth and others that are ideal for building into recesses, book cases, cabinets, etc.

Send today for complete data file on all Murphy recess, pivot and roller bed models and Cabranette Kitchens.

MURPHY DOOR BED CO., INC.
19 West 44th St., New York 18, N. Y.
Please send your free data file on Murphy Beds and Cabranette Kitchens.

NAME _____
ADDRESS _____
CITY _____ STATE _____

(C-1)



For detailed information and test data, see Sweet's File, Architectural 13g—or write for Do catalog.

The high coefficient of friction of the pure vinyl surface—even when wet—assures a safe, non-slip floor. Dodge Tile is the ideal floor for hospitals, schools, churches, hotels, stores and many other public buildings.

DODGE CORK CO., INC. • LANCASTER, PA.

LEMCO Monumental

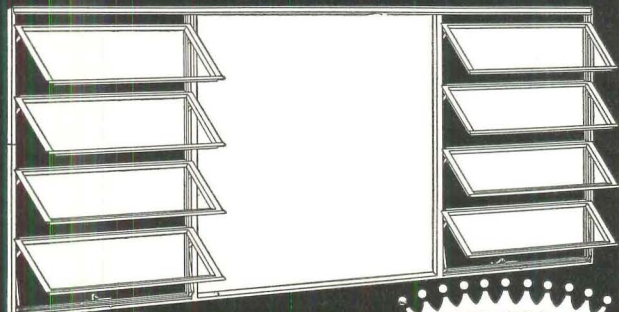

Series 62

• AWNING TYPE •
EXTRUDED ALUMINUM
WINDOWS

• Especially designed for use in
Schools, Hospitals, Public Buildings
and Fine Residences

HEAVY 2 1/8" SECTIONS

Write for descriptive literature or see our
Catalog in Sweet's Architectural File



CROFT STEEL PRODUCTS, INC.
16 MARKET STREET • JAMESTOWN, N. Y.

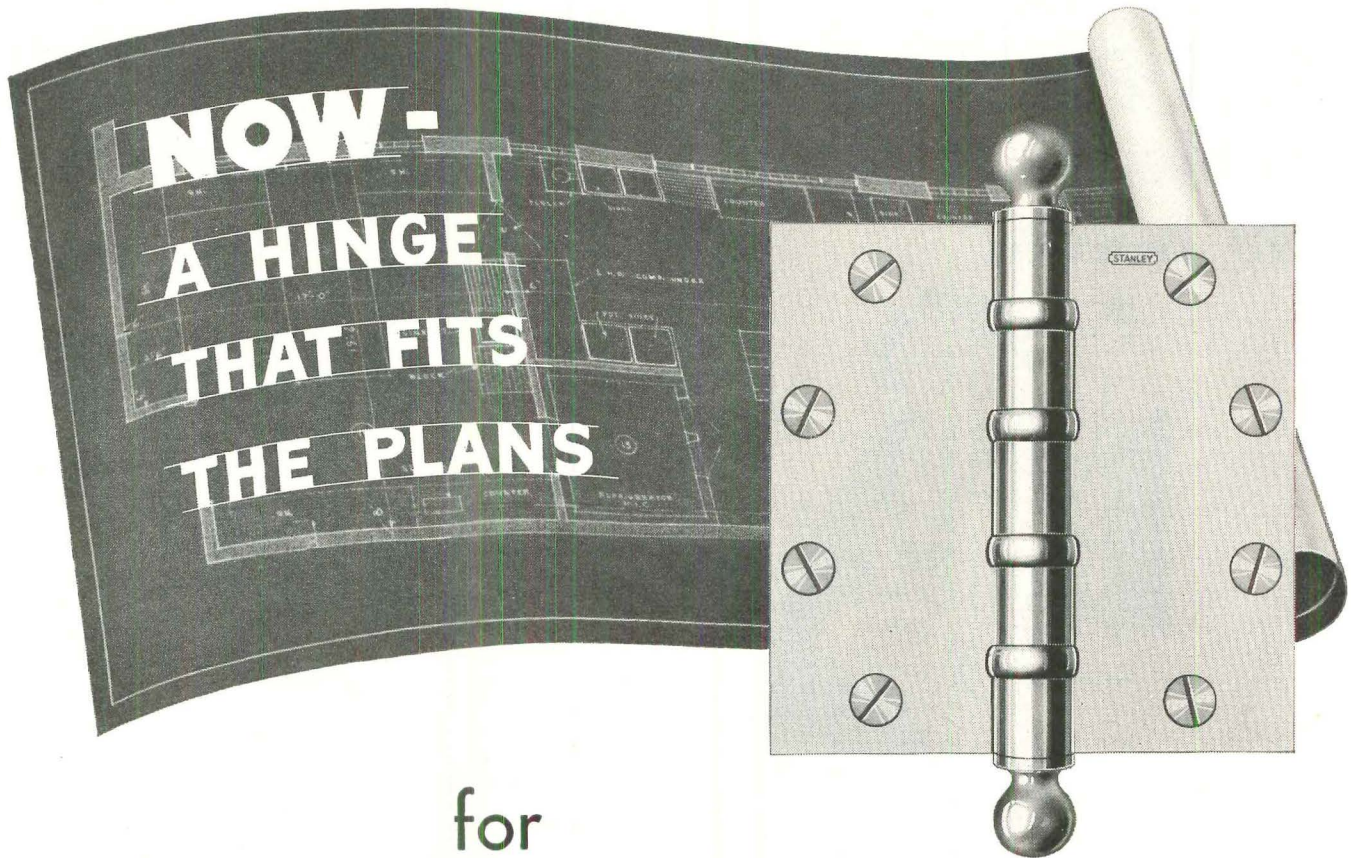

for
HEAVY DUTY SERVICE

**Full-Jeweled
 Ball Bearing Butt Hinge**

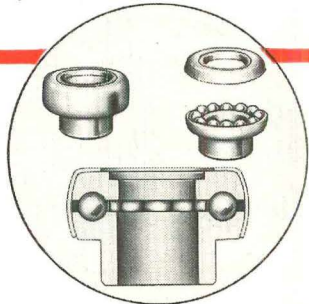

Exclusive Full-Jeweled Ball Bearing assembly consists of a movable and fixed raceway. When lateral thrust occurs, the movable raceway transmits the force directly to the bearings, which, in turn, are held firmly by the fixed raceway. Thus, the weight of the door is supported both laterally and vertically on ball bearings.

Now Stanley provides the Full-Jeweled Hinge—with new ball bearing construction for carrying *lateral* as well as *vertical* thrust. It fits the plans that require a *hinge that won't wear out*.

The Full-Jeweled Hinge is the result of exhaustive laboratory and field tests. You can specify it for heavy doors, exterior doors or for doors receiving high frequency service—with full confidence that it will last longer than any other hinge made.

Now all Stanley Extra Heavy Ball Bearing Hinges have Full-Jeweled Bearings.

REMEMBER  THREE HINGES TO A DOOR



Reg. U.S. Pat. Off.

THE STANLEY WORKS, NEW BRITAIN, CONN.
 HARDWARE • TOOLS • ELECTRIC TOOLS • STEEL STRAPPING • STEEL

"Who Says... REGULAR PHONES can handle intercom needs?"



Sure she's mad!

And you'd be too if you were trying to handle pesky (to her!) intercom messages in addition to important outside calls. Stop wasting her time and your money. Get real efficiency by installing a Couch Private Phone system . . . free outside lines . . . replace regular phones used only for intercom calls . . . reduce unnecessary calls. From 2 to 50 phones, Couch has the system right for your needs.

Write for information today.

COUCH AUTOPHONE SYSTEM

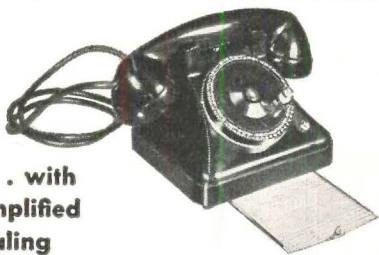

. . . with
simplified
dialing

30 or 50 line systems . . . "one shot"
dialing saves time, eliminates manually
operated switchboard . . . simple, rugged,
inexpensive.



Type 52 Four Button Model

Private Telephones
for Home and Office . . .
Hospital Signaling Systems . . .
Apartment House
Telephones and Mailboxes . . .
Fire Alarm Systems
for Industrial Plants
and Public Buildings.

S. H. COUCH co., inc.

Dept. 301

No. Quincy 71, Mass.

Hollow

Metal

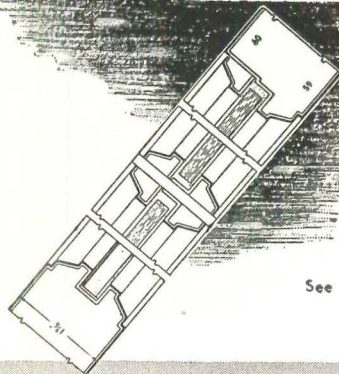

See Our Catalog in Sweet's

**JAMESTOWN METAL
CORPORATION**

104 BLACKSTONE AVENUE JAMESTOWN, N. Y.

flextures

- Eliminate costly detailing.
- Unlimited design possibilities.
- New flexibility to merchandising needs.
- Free standing and self supporting.
- An "off-the-back" effect without partitions.

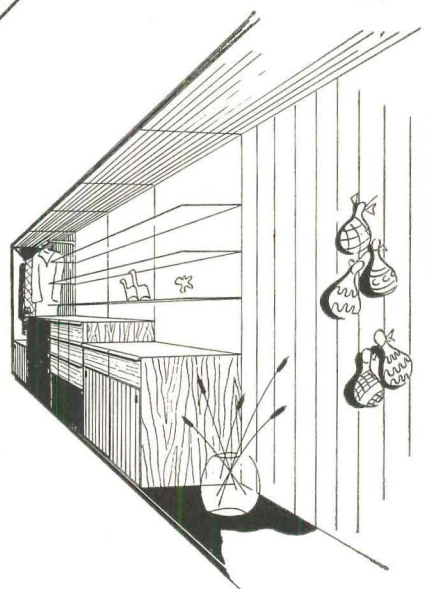

Data Sheets on Request — Dept. F-1

Grand Rapids
STORE EQUIPMENT COMPANY
GRAND RAPIDS 2, MICHIGAN

THERE'S A NEW ERA IN ELEVATOR SERVICE



How the world's smartest elevator system adds important minutes to your day

How many times have you wished somebody would develop an elevator system that would never keep you waiting . . . speed you between floors . . . and empty or fill a building in the shortest possible time?

To do just that . . . to help you save those seconds that count so much, Westinghouse developed Selectomatic—the elevator system with an “electrical brain.”

This “electrical brain” *instantly* and *automatically* matches calls to cars to floors. Result—there's always a car on its way to answer your calls quickly. Your travel time between floors is dramatically shortened by the new

Westinghouse automatic landing control, Synchro-Glide. And—this, the world's smartest elevator system, also increases the number of people handled in rush periods by as much as 30%.

All over the country new buildings and buildings being modernized are installing Selectomatic Elevators. If you're building or modernizing and are concerned with elevators—*test ride Selectomatic before you decide.*

For information on Selectomatic installations in your locality, call or write Westinghouse Electric Corp., Elevator Division, Dept. F-1, Jersey City, N. J.

Selectomatic Elevators

YOU CAN BE SURE...IF IT'S **Westinghouse**

J-98593

TECHNICAL LITERATURE

PANEL CONSTRUCTION. Cemesto Design and Construction Application Data. The Celotex Corp., 120 S. LaSalle St., Chicago 3, Ill. 40 pp. 8½ x 11 in.

Assembled to help the architect and engineer plan low cost insulated buildings, the portfolio contains drawings and design data on Cemesto board applications. These panels are described as consisting of a core of laminated cane fiber insulation material surfaced on both sides with light gray cement asbestos boards bonded with

moistureproof, vapor resistant adhesive. Uses detailed include walls, roof decks, partitions and ceilings. Simple erection and maintenance-free finish on both exterior and interior surfaces are advantages cited for the material.

ELEVATORS. Passenger Elevators. Booklet B-4572. Westinghouse Electric Corp., Elevator Div., Jersey City, N. J. 56 pp. 8½ x 11 in.

Compiled as a reference book for consulting engineers, architects and building managers, the

buyer's guide discusses vertical transportation in office buildings, hotels, department stores, apartment houses and public buildings. Detailed information presented includes: different types of elevator controls and how to select them; determining the correct number, size and capacity of elevators; dimensioned layouts; installation data; and modernization of outmoded elevator systems. Pictures, curves, tables and case examples round out the comprehensive text. Also explained is the "Protective Maintenance Agreement" whereby owners are relieved of responsibilities for proper operating condition of Westinghouse elevators.

SHEET METALS. Republic Sheets for the Building Industry, Adv 548. Republic Steel Corp., Advertising Div., 3100 E. 45th St., Cleveland 27, Ohio. 20 pp. 8½ x 11 in.

Leading off with nine cartoon-illustrated features of stainless steel, the publication discusses types, finishes, gauges, forms and properties. Detail drawings and installation photographs show how effective architectural use has been made of this versatile construction material. Although it deals essentially with applications of Enduro stainless steel, the booklet includes data on the manufacturer's other sheet metal products made of iron, zinc and copper alloys. The section on specifications should help architects who wish to order Enduro.

MORTAR. Omicron Mortarproofing for Tight Brick Walls. The Master Builders Company, 7016 Euclid Ave., Cleveland 3, Ohio. 16 pp. 8½ x 11 in.

Causes of leaky brickwork and how they can be remedied with the help of Omicron Mortarproofing are described in this illustrated booklet. Featured in the publication are laboratory test results which indicate how this water-reducing mixture improves the properties of various mortars—job-mixed cement lime, masonry cement, and prepared mixes. Among the benefits itemized are improved workability with less water, reduced shrinkage, better bond, and less water absorption.

CONCRETE BLOCK. Santomerse S in Concrete Block Manufacture. Monsanto Chemical Co., Phosphate Div., St. Louis 4, Mo. 4 pp. 8½ x 11 in.

Procedures for using the firm's liquid wetting agent *Santomerse S* in making concrete blocks are described in this technical bulletin. Denser, stronger and more uniform concrete products are said to result from the addition of small amounts of the chemical. Other advantages cited are improved plasticity, lighter color, cleaner equipment and better dispersion of cement.

GRANDSTANDS. Wayne Type "H" Grandstands. Wayne Iron Works, Wayne, Pa. 4 pp. 8½ x 11 in.

A portable steel grandstand which is said to cost only slightly more per seat than wooden bleachers is the subject of this brochure. Design and construction details of several styles are fully illustrated. (Continued on page 242)

rugged roofing for el rancho

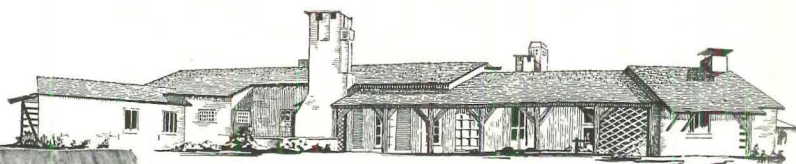

Above and below. Residence: J. W. Runyon, Dallas, Tex. Architect: Chas. S. Dilbeck



Ludowici Tile
 Reproduction of Shingle Tile showing the authentic character of the old wood shake.

OUT ON THE PLAINS of Texas and in the great Southwest, the people know the kind of roof that serves them well and has done so since long before the Alamo . . . Tile. Tile is on the missions, the cathedrals, the haciendas, and Ludowici shale tile in its many authentic styles and colors can serve you and your clients, too, because this is a roof that *does* serve anywhere. Almost imperishable, it is definitely economical. Architecturally correct, it is beautiful, and for any type of building a tile roof is wholly dependable with a minimum of installation and maintenance cost.

Inquire about Ludowici roofing tiles. We shall be glad to show you samples and send full information upon request. See our catalog in Sweet's.

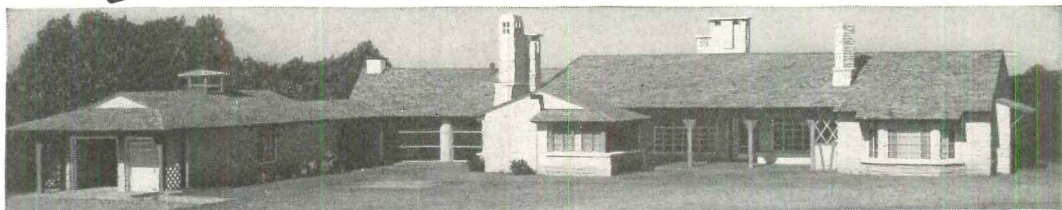

New York 17, New York
 565 Fifth Avenue
 Washington 5, D. C.
 740 15th Street, N. W.

LUDOWICI-CELADON CO.
 104 S. Michigan Avenue, Chicago 3, Illinois

Cleveland 20, Ohio
 12734 Woodland Avenue

America's Most Admired Fixture!

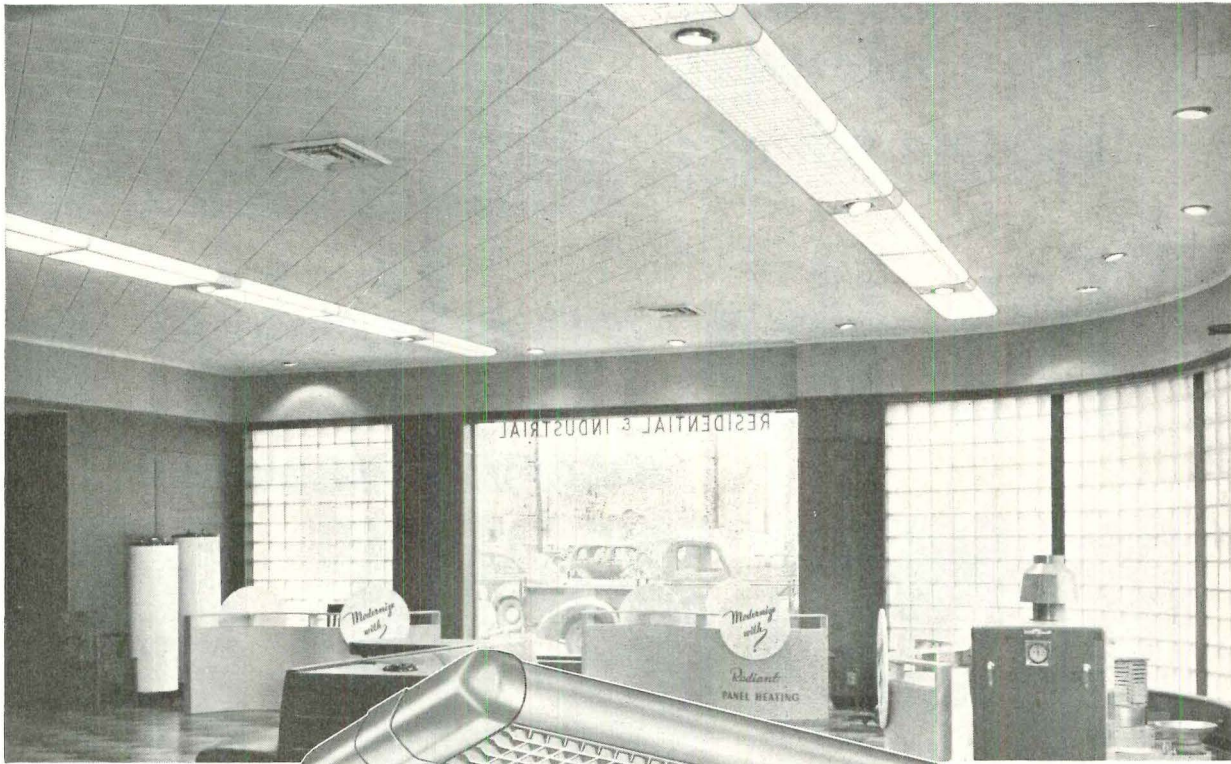

**Illumination PLUS
Point-of-Sale Merchandising
Wins New Friends for**

Leader **OFFICER**

VL and NHC Series

**LEADER VL-440
SPECIFICATIONS**

Housing, channel and deep drawn end caps of 20 gauge steel, finished in white, high-gloss baked enamel. Extruded tubular side panels and moulded one-piece louver is of glowing white plastic that is warp-proof, colorfast, and destaticized. Louver swings down for easy servicing. Choice of 31° or 45° shielding. May be used as single units or in continuous runs—suspended or ceiling mounted. VL Series uses 2, 3 or 4 40-watt 48" T-12 lamps. Wired units include UL and ETL approved sockets, type FS easily replaceable starters and two high p.f. 2-lamp ballasts. Conventional 110-125 volts, 60 cycle A.C. Other voltages on request. NHC Series available for use with Slimline tubes and for 120, 200, 300 or 425 milliamper operation in lengths from 48" to 96".

You'll find this attractive fixture installed in the most tastefully decorated offices, stores and office buildings. The "Officer" not only adds to any decorative effect, but helps sell goods and services through appealing highlighting of floors, furniture and display sales material. The LEADER "Officer" is rich in construction, too. For example, it is provided with the famous LEADER one-piece louver of destaticized plastic... a louver with a multitude of small, rigid apertures—made possible by one-piece molding—to provide excellent shielding and soft, gracious light-diffusion.

**Sold and installed only by the better
electrical wholesalers and contractors**



Leader **America's No. 1 Lighting Equipment Manufacturer**

LEADER ELECTRIC COMPANY • 3500 NORTH KEDZIE AVENUE • CHICAGO 18, ILLINOIS
LEADER ELECTRIC—WESTERN • 800 ONE HUNDRETH AVENUE • OAKLAND 3, CALIFORNIA

From Maryland to California and all stops in between, builders tell us :



"It's the realistic way



Mr. J. P. Lenny, President of J. P. Lenny Co., Runnemede, N. J., says:

"Credit restrictions will make the market more competitive . . . impose upon the builder the necessity of producing a product that will invite eager consumer acceptance."

"In planning our new 1951 'Cinderella Homes' we intend to emphasize the use of General Electric Kitchens."

"We used G-E appliances during 1950, and sold 55 of our 137 houses on opening day!"



Mr. M. T. Broyhill made his own private survey in Washington, D. C. to find out what people wanted most. He says:

"83% of the people interviewed said they wanted a General Electric Kitchen. So we built 1000 G-E equipped houses—and sold all of them within 60 days."

Mr. Broyhill also reports: "During 1951 it's more important than ever that we give house-hunters what they want."

"We wouldn't think of *not* including the G-E Kitchens."



Mr. Frank F. Sebastian, President and Director of Arden Manor Investment Co., Sacramento, Cal., says:

"All 2200 homes in the Arden Manor Community are to be completely equipped with General Electric Kitchens and Laundries."

"More than ever, this major feature gives our homes a distinct advantage over others selling in the same price field."

"We think it's the realistic way to sell houses in 1951."



Mr. H. R. Houck of Houck Realty Co., Houston, Texas, says:

"We sold 170 houses equipped with G-E Kitchens during 1950. This year we again plan on featuring G-E Kitchens because we know it gives our homes an edge over others in about the same price bracket."

Mr. Arthur Oman of Arthur Oman & Sons, Inc., Brockton, Mass., says:

"During 1950 we included G-E Kitchens in our Brook Hill Development houses. We sold 125 houses in just 10 days! Naturally, we expect to capitalize on our success with G-E Kitchens during 1951."





Mr. Thomas P. Coogan, President of the National Assn. of Home Builders, states:

"I have been particularly pleased with the General Electric appliances installed in our exclusive Bal Harbour Manor.

"We all know that considerably greater selling effort will be required during the coming year. And the builders who will profit most are those who use initiative and imagination."



to sell Houses in '51"



Mr. Michel Randal of Randal Associates is planning to include General Electric appliances in his new 350-home project at Richmond Park, Bethpage, Long Island, N. Y.

"In selling houses these next 12 months," says Mr. Randal, "the General Electric Kitchen can be a more potent selling tool than ever!

"We're looking forward to offering these excellent, *all-electric* appliances in our homes!"

WE DON'T HAVE TO TELL YOU that fewer houses will be built this year.

But the fact remains that hundreds of thousands of houses will be built and sold during 1951.

And, the houses that will sell the *fastest* in this more competitive market will be the very type that sold fastest during 1950... houses with all-electric living... houses with the efficient General Electric Kitchen-Laundry!

**MORE THAN EVER—
IT PAYS TO FEATURE
THE GENERAL ELECTRIC
KITCHEN-LAUNDRY**

1951 Planners from St. Louis, Wichita and other cities also agree . . .

Mr. N. R. Schuermann of St. Louis, Mo., says:

"Last year more than 7000 came to see our house on opening day and 109 bought. We sold over 500 houses equipped with General Electric Kitchens.

"During 1951 the home with the General Electric Kitchen will have even a greater appeal and advantage over others in a

similar price range."

Other successful builders from Wichita, Terre Haute, Chicago, and other areas also agree with Mr. Schuermann's basic views.

IMPORTANT NOTE: *Since considerably greater selling effort will be required for your houses during 1951, why not put General Electric on your selling team?*

**SEE
NEXT TWO
PAGES FOR
ADDITIONAL
DATA** 

GENERAL  ELECTRIC

Which plan will you



Why not let G-E pre-sell your houses?

General Electric offers you all this:

- Tested merchandising programs that have helped so many other builders enjoy phenomenal sales results.
- The brand of electrical appliances that people prefer to all others.
- One source of supply for matched equipment . . . a full line of cabinets and appliances.
- Assistance in designing and improving kitchen layouts for your houses.
- And most important: G-E equipment is world-famous for its *dependability!*

You can put your confidence in—

GENERAL  ELECTRIC

offer home buyers?

◀ This efficient General Electric Kitchen includes: Automatic Dishwasher-Sink and Disposall,[®] Automatic Washer, Range, Refrigerator, and all-steel cabinets.

You can offer this General Electric Kitchen to your prospects for as little as \$5.94 extra a month through a long term "Packaged Mortgage" plan. As so many other builders are planning to do, *feature* the General Electric Kitchen-Laundry in the homes *you* build.

▶ People must have a refrigerator and a range to *live* in your house. Just to buy a refrigerator and a range, under present credit regulations, would cost them about \$25.50 a month over and above their regular mortgage payments.

On the other hand, you can give them a complete General Electric Kitchen for only \$5.94 a month! Which plan will you offer home buyers?



\$25.50
EXTRA A MONTH
for these two G-E
Appliances

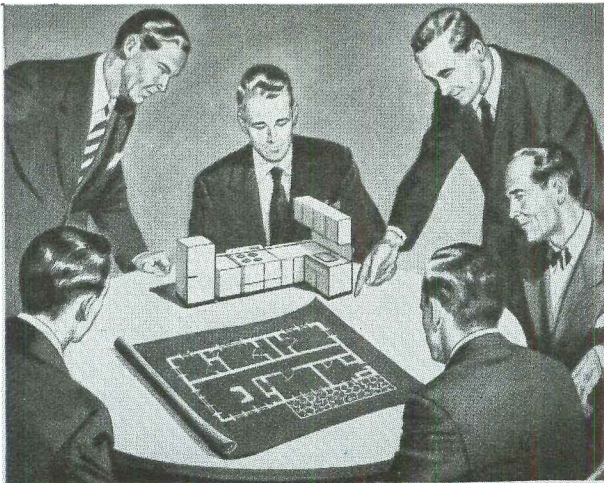

TAKE ADVANTAGE OF OUR ARCHITECTURAL CONSULTING SERVICES AT THE CONVENTION

General Electric planning experts will be glad to talk with you about your 1951 projects at the Chicago Convention.

Look for Booths 115 and 116

Our Architectural Consulting Service, we believe, can be of great assistance to you in designing and improving kitchens and layouts for your houses.

So make it a point to bring your house plans to Chicago. However, if you can't be at the Convention, contact your G-E Distributor, or address a note to us and we'll see that you receive all the facts you need. Home Bureau, General Electric Company, Bridgeport 2, Connecticut.

TECHNICAL LITERATURE

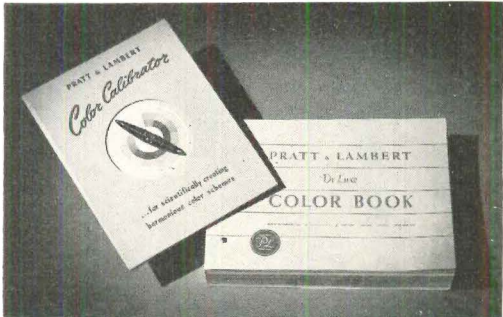

COLOR. Color Calibrator and DeLuxe Color Book. Pratt & Lambert, Inc., 75 Tonawanda St., Buffalo 7, N. Y. 200 pp. 10 x 14 in.

This new color wheel device and swatch book provide a simple yet accurate method of creating innumerable decorative color schemes. The sturdily bound calibrator has a 12 spectrum color wheel divided into pie-shaped segments or color families. Pointers, fixed at the hub of the wheel, may be manipulated very easily to assemble two

to six related tones appropriate for interior color schemes. The companion book contains two sheets each of 100 selected colors, code lettered to correspond to the families on the calibrator. The sheets are perforated into 30 swatches, and a formula for attaining the exact shade printed on the back of each swatch.

LIGHTING. Curtis Coronet Series, Bulletin #2413. Curtis Lighting, Inc., 6135 W. 65th St., Chicago 38, Ill. 16 pp. 8½ x 11 in.

A new series of fluorescent luminaires for stores, offices and schools is detailed in this publication. Practical in design, the fixtures feature louvers on a chain assembly which may be lowered for easy access to the ballast and wiring.

PLUMBING. Corrosion of Brass Pipe and Copper Tubing. Water Service Laboratories, Inc., 423 W. 126th St., New York 27, N. Y. 2 pp. 8½ x 11 in.

Preserving the efficient lifetime of piping makes good sense in this time of imminent metal shortages. Described in the bulletin are the corrosive effect of water on different kinds of brass pipe and copper tubing and its recognizable symptoms. How water supply can be treated chemically to minimize damage from corrosion is explained, and a list of references included.

VENTILATION. Residential Ventilation Guide. Propeller Fan Manufacturers' Assn., 2159 Guardian Bldg., Detroit 26, Mich. 10 pp. 8½ x 11 in.

A development of the *Attic Ventilation Code*, this nontechnical guide covers all current phases of mechanical ventilation in homes. Three types of kitchen fans are discussed as well as window fans and fans for bathrooms and basements. Good illustrative diagrams, definitions, and a table of air changes are also included.

AIR DIFFUSERS. The Anemostat Air Diffuser. Anemostat Corp. of America, 10 E. 39th St., New York, N. Y. 6 pp. 8½ x 11 in.

An interesting account of the development of aspirating air diffusers introduces a description of the manufacturer's various models. Their patterns of air distribution are clearly illustrated by diagrams, and the booklet gives engineering data and formulas for calculations used to solve particular air conditioning problems.

COLOR. Nu Hue Colors Professional Guide. Martin Senour Co., 2520 S. Quarry St., Chicago 8, Ill. 12 pp. 5 x 8½ in. \$1.

This handy color guide contains 160 different painted chips which can be mixed from 16 basic colors plus white. Chips are arranged so that color harmonies "read" easily across the chart. Slotted cards provided with the guide may be placed over various sections to reveal numerous color plans. Each chip has a key number which corresponds to a formula. All the formulas are quite simple to follow. Not more than two liquid tints (in equal amounts) are used with white in any of the 160 tones. The quantity of white in all the mixtures is standard—one gallon.

OVER HALF OF ALL REVOLVING DOORS SOLD REPLACE SWING DOOR ENTRANCES

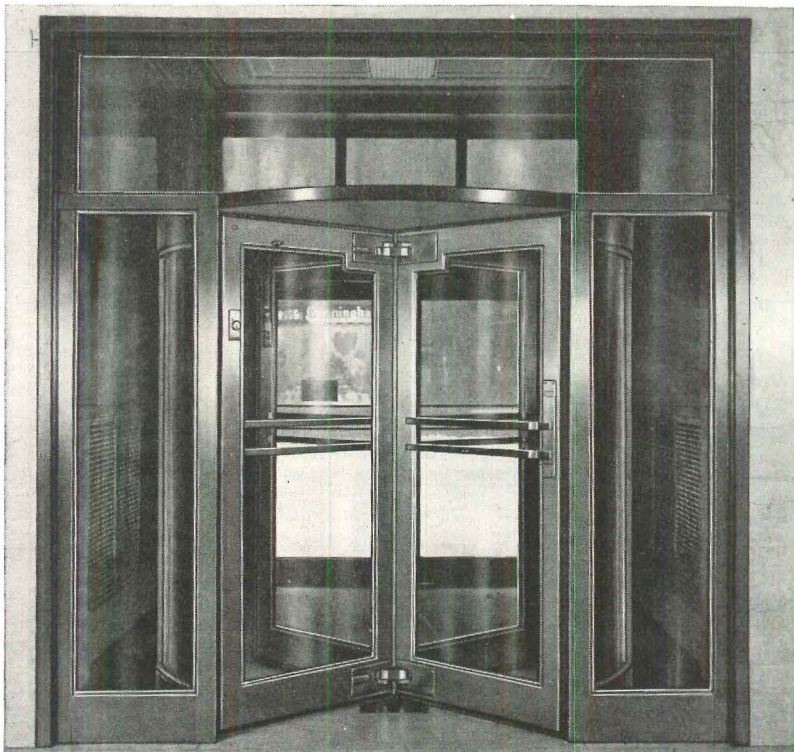

Detroit Bank, State and Griswold, Detroit, Michigan

More and more — building and store owners are finding out — all too late — that only revolving doors will handle their entrance problems. This is why more than half of all revolving doors installed are replacements for swing door entrances. Be wise — be thrifty — specify International-Van Kannel revolving doors.



FOR INFORMATION — Consult your telephone directory under Doors, Revolving, or see our catalog in Sweet's.

1812 EDGAR STREET EVANSVILLE 7, IND.

IN CANADA — International-Van Kannel revolving doors are available through Eastern Steel Products, Ltd., in Toronto and Montreal.

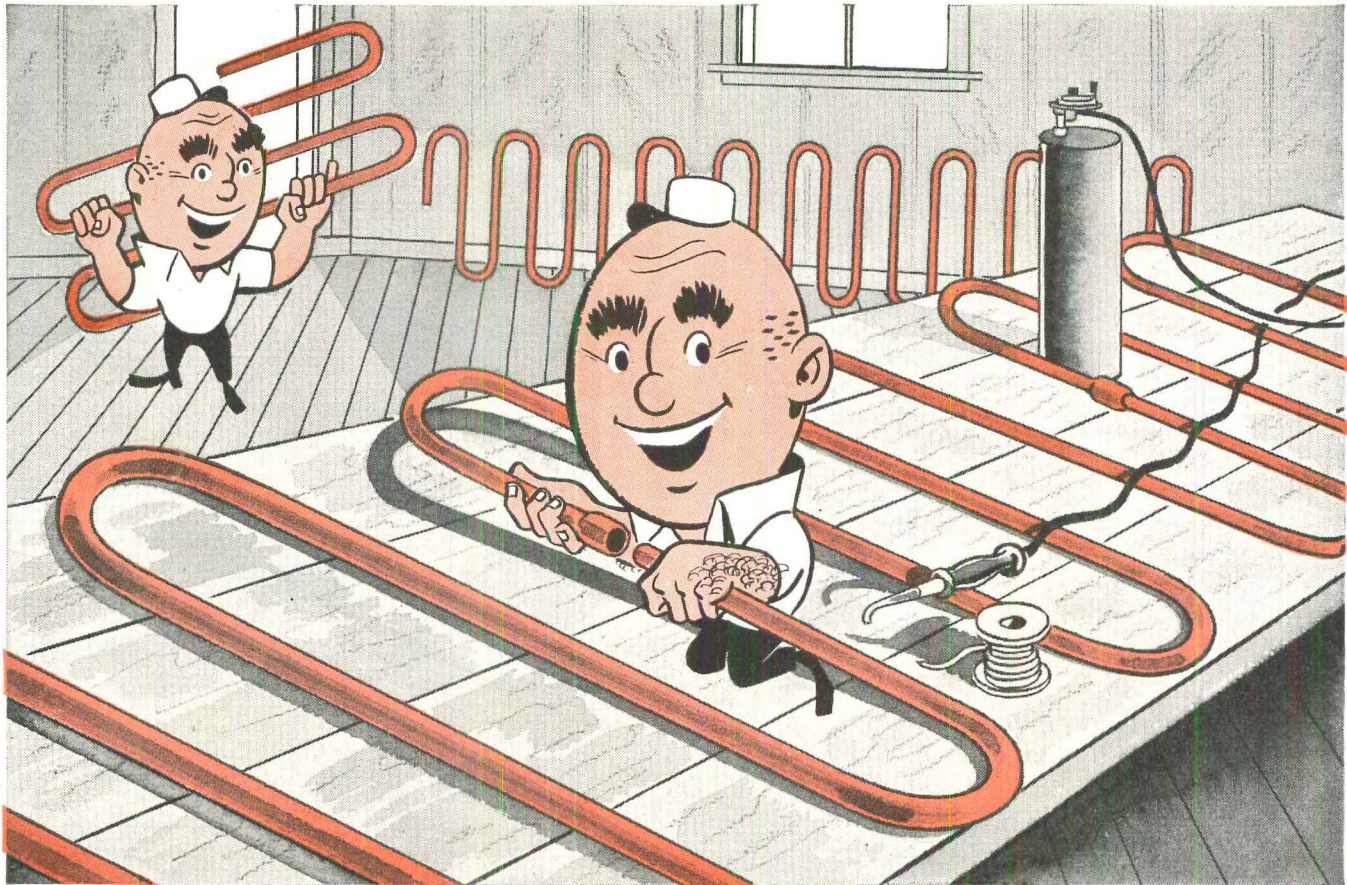

Form radiant heating grids faster, too ... with Bundyweld

NOTE that Bundyweld expanded end, above. It spells *even easier* radiant heating installation!

For twenty-foot lengths of Bundyweld Tubing can be sent to your building site with one end expanded (*if specified*). Then, one man quickly forms grid on simple fixture . . . slips unexpanded end into expanded end of the next grid, and silver brazes (or soft solders) grids into strong, permanent, leakproof union.

Two men can easily position the rigid, lightweight Bundyweld sections on ceilings or in floors. No hitches,

delays. In jig time, your Bundyweld radiant heating system is all set, to the tune of a major savings in time and costs.

Bundyweld is double-walled from a single strip, copper-bonded through 360° of wall contact. It's stronger-walled, thinner-walled; bends more readily without collapsing structurally. Uniformity, even flow, maximum heat conductivity are yours!

Write today for the complete Bundyweld radiant heating story. **Bundy Tubing Company, Detroit 14, Michigan.**

Bundyweld Tubing

DOUBLE-WALLED FROM A SINGLE STRIP

WHY BUNDYWELD IS BETTER TUBING

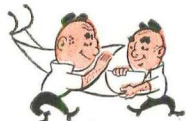

Bundyweld starts as a single strip of basic metal, coated with a bonding metal. Then it's . . .



continuously rolled twice around laterally into a tube of uniform thickness, and



passed through a furnace. Bonding metal fuses with basic metal, presto—



Bundyweld . . . double-walled and brazed through 360° of wall contact.

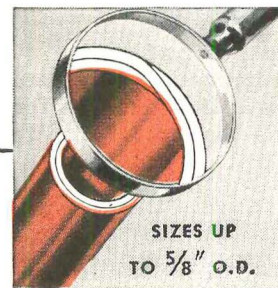

SIZES UP
TO 5/8" O.D.

NOTE the exclusive patented Bundyweld beveled edge, which affords a smoother joint, absence of bead and less chance for any leakage.

What do you want in a lock?

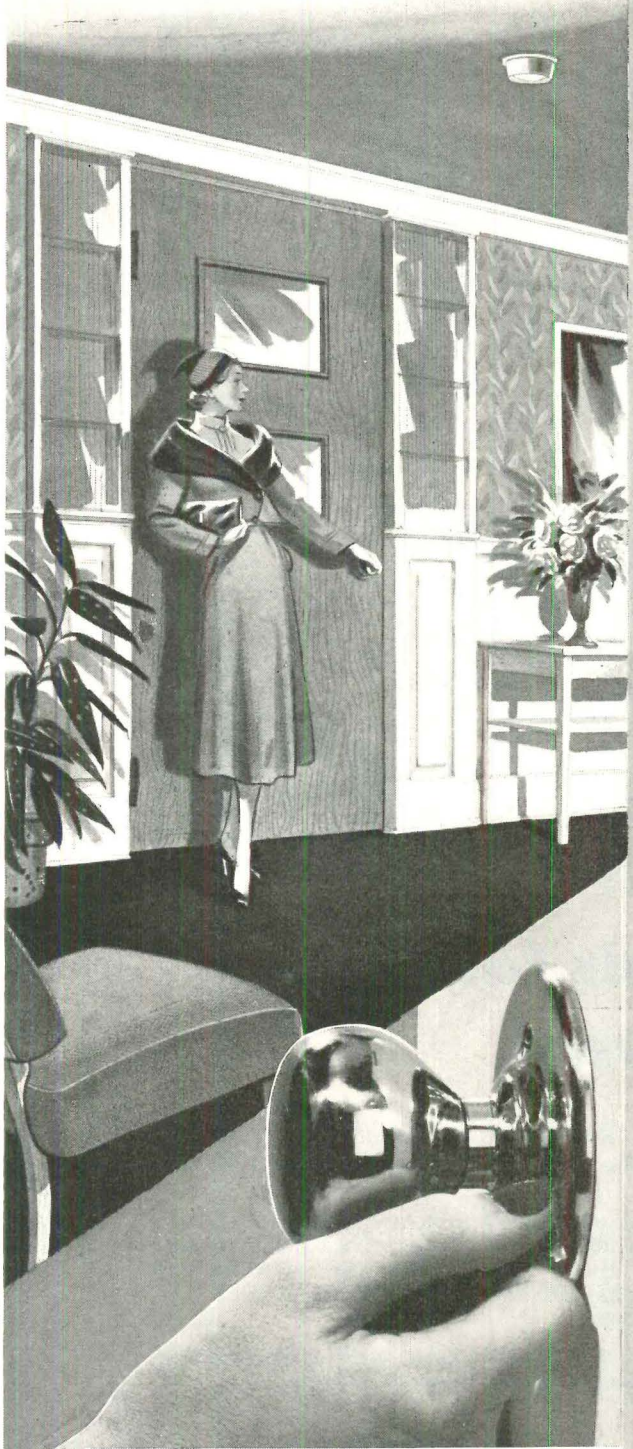

Security

Positive protection of a deadbolt, shearpin in knob prevents forcing, *secure* is the word for Sargent's Integrallock.

Write us for information about Integrallock, the superior mortise or unit lock that is styled for today.



Sargent and Company

New York **NEW HAVEN, CONN.** Chicago

Builders Hardware and Fine Tools since 1864



Wood finely fashioned

.. does so much for a kitchen!



For a friendly, livable kitchen nothing quite takes the place of hardwood cabinets — their warmth and beauty, their permanence, their adaptability to

home design and decoration. And in cabinets by Kitchen Maid you get wood at its best; selected hardwoods and wood compositions, finely fashioned and masterfully constructed by the nation's foremost wood cabinet maker. Kitchen Maid cabinets are in greater demand now than at any time in history. Their fine quality is recognized by builders everywhere. Choose them for the kitchens you plan or build. For free

catalog showing plans and details, send coupon below.

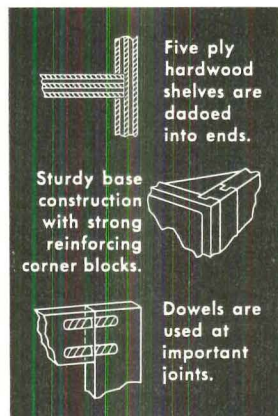

KITCHEN MAID
FIRST AND BEST IN
KITCHENS

Look for this sign



Look for this sign in your dealer's window. It signifies his skill as a member of the nation's oldest kitchen planning organization.

THE KITCHEN MAID CORPORATION
611 Snowden Street, Andrews, Indiana
Please send new booklet containing 10 practical kitchens with details. I am an Architect, Builder, Dealer.

Name _____
Address _____

PUSH... and electrical service is restored with Bulldog

Pushmatic[®]

THAT'S ALL there is to it! A simple push of the finger makes or breaks the circuit. No resetting manually when the circuit is broken by short or overload. Just PUSH—and service is restored.

Pushmatic is compact, sturdy, simple . . . the most versatile and flexible unit available today. It will meet every new or changing load condition.

And *Pushmatic* units are easy to install! There are no complicated group mountings . . . individual single-pole units make additions and changes a simple matter.

Pushmatics are available in THERMAL-MAGNETIC or THERMAL-MAGNETIC with exclusive AMBIENT COMPENSATING FEATURES. All are identical in size and contour, in ratings of 15, 20, 30, 40, and 50 amperes, 120 V., 1 pole, or 120-240 V., 2 poles, AC. All are interchangeable for rating and type.

Write today for new *Pushmatic* Bulletin. This descriptive bulletin contains complete information and prices on Bulldog Electri-Centers and the new *Pushmatic*.

PUSH

it's ON!

it's OFF!

it's ON again!

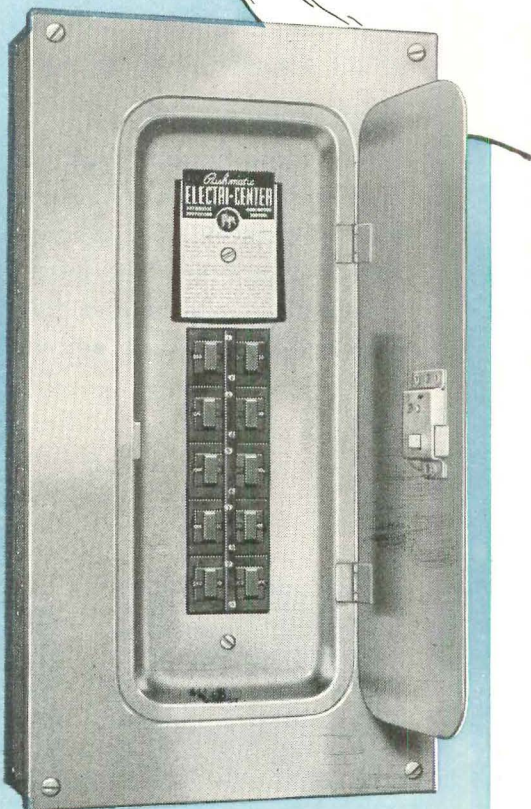

Only *Pushmatic* Electri-Centers provide push-button control, automatic protection!

REVOLUTIONARY, new *Pushmatic* ELECTRI-CENTERS provide electrical control centers that are the last word in efficiency and protection.

They are attractive, compact, simple . . . easy to wire. There's plenty of gutter room even in the smallest cabinets.

With Electri-Centers there are no fuses to buy, no complicated operations or installation techniques to remember. You get versatility and adaptability, ease of installation and operation *never before obtainable in any panelboard*.

See the new ELECTRI-CENTERS at first opportunity, or write today for new *Pushmatic* Bulletin.

BULLDOG ELECTRIC PRODUCTS COMPANY

DETROIT 32, MICHIGAN — FIELD OFFICES IN ALL PRINCIPAL CITIES

IN CANADA: BULLDOG ELECTRIC PRODUCTS OF CANADA, LTD., TORONTO



BULLDOG

HEADQUARTERS FOR ELECTRICAL DISTRIBUTION

Cements: their proper selection and use

1. SELECTION

In selecting and specifying acoustical materials, there is a great tendency to overlook the cement used for their installation. In the cases where cements are covered by the specification, the usual method is to say simply, "cement shall be as recommended by the manufacturer." This specification is, in actual practice, so open that the specifier has little assurance of getting the kind of cement he should have.

When an acoustic cement fails—by losing its bond—the acoustical material is sure to fall. Of course, all cements will hold the material in place for a time, usually well beyond the guarantee period. That, however, is of little help to the owner if the cement begins to fail a year or two later. The great difference between a good and a bad cement is the length of time it will maintain a good bond. Fundamentally, that depends upon the ability of the cement to remain plastic, not just for a year or two, but indefinitely. A good cement must also have a good initial bond and minimum shrinkage tendencies.

To reach a proper balance among these properties requires a careful blending of selected solvents, binders, plasticizers, and other elements. If too much

emphasis is placed on initial bond, the cement may soon become hard and brittle, and it may shrink or crack loose with normal expansion and contraction of the building. On the other hand, if there is too much plasticity, the initial bond may be poor.

VARNISH-TYPE BASE MOST SUCCESSFUL

Cement specialists in Armstrong's Research Laboratories, after many years of work on acoustical cements, have found that best results are obtained by formulating the cement with an "oleo-resinous," or varnish-type base, made of a combination of resins and drying oils. Even after the solvents evaporate, this type of cement remains tough and plastic because the drying oils continue to serve as a plasticizer and binder. Shrinkage, the greatest cause of ceiling failures, is minimized by this type of formulation.

WHAT ABOUT COST?

While it cannot always be said that a cement can be judged by its cost, it should be borne in mind that the cost of ingredients for a good quality cement will generally keep it out of the "bargain price" category. Obviously, it is false economy to risk the failure of a fine acoustical job by saving a few dollars on cement.

COMPETITIVE TEST SAMPLES — AFTER 8 YEARS



1

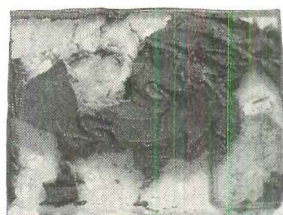

2

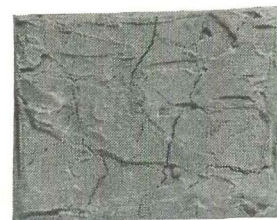

3



4

Each of the above samples was subjected to a severe 30-day accelerated drying test at 120° F. These unretouched photographs were taken eight years later. The first three samples, typical of many more tested, showed brittleness and cracking in varying degrees. The fourth one, the Armstrong sample, remained plastic. Surface marks on it are thumb nail indentations made during periodic inspections.

HOW TO SPECIFY A GOOD CEMENT

In order to insure that you get a satisfactory cement for your acoustical installation, it is important to cover the cement in your written specifications. If you prefer not to select a brand or manufacturer by name, you may write an open specification as follows:

The acoustic cement shall be composed of a varnish-type vehicle which contains drying oils, high oil-absorbing clay, and at least 3% short-fibered asbestos.

The United States Treasury Department uses its own specification (No. 261A) to cover procurement of acoustic cements. This is one of the few detailed specifications that has ever been written for acoustic cements. It prescribes definite tests for strength, plasticity, waterproofness, and alkali resistance. These specifications, written in 1940, may still be referred to as a means of eliminating the most inferior cements, but they do not assure getting the best. Armstrong's Acoustic Cement, for example, is manufactured to exceed the Treasury specification for bonding strength by two times. It exceeds the other test requirements by wide margins.

2. APPLICATION

The best cement cannot insure a successful installation unless it is applied properly. The photographs at the right show the approved step-by-step procedure, as used by Armstrong Acoustical Contractors.

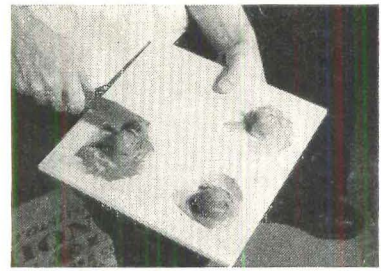
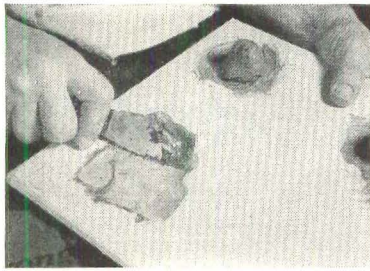

First, with a putty knife or small trowel, a little of the cement is scraped onto the tile to serve as a primer for the spots where the cement will go. Then, the cement is applied in heavy gobs, about the size of a walnut—four to a square-foot tile. Gobs should be kept about an inch from outside edges.

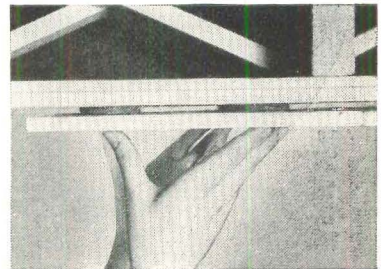

The tile is placed on the ceiling about one-half inch from its final position and moved into place under pressure with a back-and-forth sliding motion. This spreads the cement and assures a good bond with the ceiling surface. During this process, the cement is used as a means of leveling the tile.

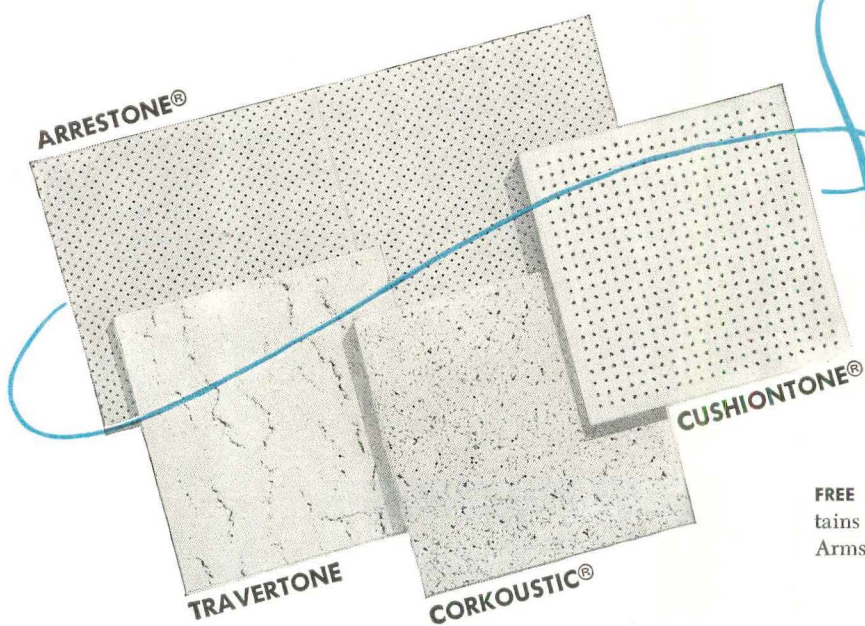

**ARMSTRONG'S
ACOUSTICAL
MATERIALS**

FREE BOOKLET, "How to Select an Acoustical Material," contains important facts about sound conditioning. Write to Armstrong Cork Company, 5401 Stevens St., Lancaster, Pa.



Get ALL these advantages in the fountain you buy



A-5 8

The Halsey Taylor line of fountains and coolers has always represented the ultimate in artistic appearance and mechanical design! The distinctive, health-safe Halsey Taylor projector and automatic stream control promote economy in operation and freedom from servicing annoyances. Get our new 1951 catalog—now!

THE HALSEY W. TAYLOR CO., WARREN, O.

The Little Cooler for Little People

This ideal cafeteria cooler is the right height for children. Foot-pedal operation means extra convenience for the child.



Halsey Taylor *Fountains and Coolers*

FOR EXTRA METAL PROTECTION AND EXTRA PAINT DURABILITY ...SPECIFY ACP RUST PROOFING CHEMICALS AND PROCESSES.

For over 1/2 of a century, ACP has pioneered in the development of protective metal-working chemicals. These chemicals preserve the metal and the paint finish of both industrial and military products.

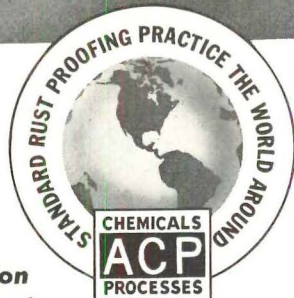

To assure extra protection and extra paint durability for . . .

STEEL, Specify: All steel materials shall be Granodized with "Granodine".®

ZINC, Specify: All zinc and galvanized iron materials shall be Lithorized with "Lithoform".®

ALUMINUM, Specify: All aluminum materials shall be Alodized with "Alodine".®

Write or call for further information. ACP Chemicals Meet Government Specifications.

Pioneering Research and Development Since 1914

AMERICAN CHEMICAL PAINT COMPANY
AMBLER, PA.

Manufacturers of METALLURGICAL, AGRICULTURAL and PHARMACEUTICAL CHEMICALS

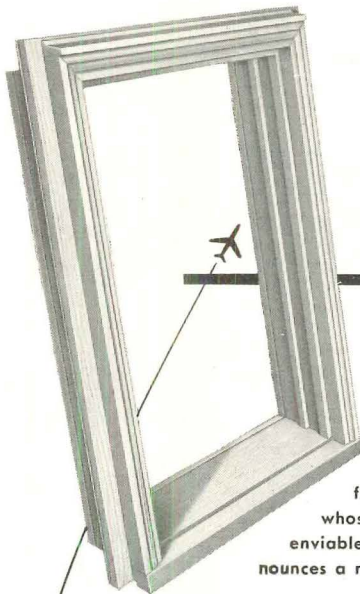

Malta

famous for QUALITY
leader in FRAME DESIGN

Building Design, 1951, demands materials and methods in tune with the future. The MALTA Manufacturing Company, whose Supreme window frames have gained an enviable reputation for quality for fifty years, announces a newly designed line with the future in mind.

Architects and builders will be quick to recognize MALTA'S many superiorities. The patented head, jamb and sill features that have made MALTA outstanding are incorporated in the new frames. They adapt to any wall construction and, with liners, fit any desired wall thickness. These features save time and labor on the job.

This Portfolio will prove Useful to you . . .

Write today for this portfolio of catalog sheets with specifications and detail drawings of individual frames.

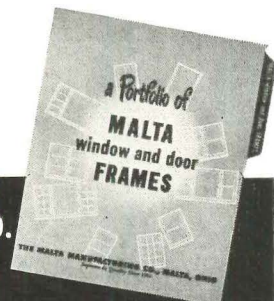

THE MALTA MANUFACTURING CO.

MALTA, OHIO
SUPREME QUALITY FOR FIFTY YEARS

GUNNISON HOMES

Builder of Homes for the Nation Chooses

American Kitchens



Why this famous manufacturer of high quality homes uses American Kitchens exclusively!

General John J. O'Brien, President of the Gunnison Company wrote us: "We have a reputation of which we are proud—that Gunnison Homes incorporate only the finest materials and appliances. That is the reason, of course, that all Gunnison Homes have American Kitchens. The kitchen is almost the first thing a woman wants to see about a house—and we've found again and again that American Kitchens sell our houses faster."

Builders everywhere have discovered the popularity of American Kitchens—the beautifully designed kitchen that most women want. And they've discovered, too, that American Kitchens increase the value of their homes—without increasing the cost. American Kitchens in the homes you build become a visual sign of quality to give your clients confidence that the hidden materials are top quality too!



American KITCHENS

See us at N. A. H. B. Show, Booth No. 2
Stevens Hotel, Chicago, Jan. 21-25

New Gunnison
Coronado 4-H Home features
three bedrooms and six big closets

American Central Div., Dept. MB1
AVCO Mfg. Corp.
Connersville, Indiana

Please have my distributor send me
your new 1950 Builders' File.

Name _____
Address _____
City _____ County _____ State _____

AMERICAN CENTRAL
DIVISION



CONNERSVILLE,
INDIANA

HOW TO ACQUIRE
a fresh approach to small house design ... in just 5 short days
Annual CONVENTION-EXPOSITION
 NATIONAL ASSOCIATION OF HOME BUILDERS
 JANUARY 21-25
 CHICAGO

ARCHITECTS WELCOME

NAHB invites you to join in promoting a great new era of architect-builder cooperation. The incomparable facilities of our famous Convention-Exposition afford all of us a splendid opportunity to carry this great program forward.

An exciting array of outstanding Convention-Exposition features awaits you—each and every one an event of positive personal benefit to you.

***ARCHITECTURAL DISPLAYS**—Prize winning entries in the House Design Competition sponsored by NAHB and The Magazine of Building will be shown for the first time. See this inspiring evidence of architect interest in home building. A challenging, provocative exhibit, well worth a trip to Chicago.

***CONVENTION PROGRAM**—The subject of better house design and architect-builder teamwork will be given a prominent place in Convention sessions. Be here—express your views—hear others!

***TECHNICAL CLINICS & DEMONSTRATIONS**—Do your designs take advantage of new construction methods and the latest technical developments in home building? Modern times demand modern methods! Get the facts here.

***GIGANTIC EXPOSITION**—NAHB presents a spectacular display of new and improved building materials and equipment. Over 160 leading manufacturers are represented. New ideas galore!

These and dozens of other stimulating features of interest to architects and builders alike are open to you at NAHB's big show. In just 5 short days you can tap this rich reservoir of fresh ideas and equip yourself to do a far better job in the months and years ahead.

REGISTER NOW! HERE'S HOW. Members of local NAHB chapters register through their local secretaries. All others use coupon below. Advance registration (\$15 for men, \$10 for wives) must be sent with hotel reservation request. Confirmation and registration certificate sent to you at once. Make checks payable to National Association of Home Builders. If registration is for more than one person, please give, on separate sheet, names, addresses, business classifications and dates of arrival.



National Association of Home Builders
 Convention & Exposition Headquarters
 111 W. Jackson Blvd., Chicago 4, Ill.

Enclosed find my check for \$.....
 Please make hotel reservations for arrival January.....

NAME.....
 STREET.....
 TOWN OR CITY.....STATE.....
 BUSINESS.....

"The bonds I bought for our country's defense will see my twins through college!"



HOW U.S. SAVINGS BONDS ARE PAYING OFF FOR Mrs. Mary Callon OF INDIANAPOLIS, INDIANA

"Janet and Jack are my twin reasons for buying bonds," says Mary Callon. "I've been a widow since the children were 8, but in 1942 I started buying bonds for defense and for their college education, setting aside 10% of each week's pay.

"I've saved systematically through the Payroll Savings Plan at the U.S. Naval Ordnance Plant, where I'm an executive secretary.

"It's Butler University for my twins this fall—and I have my U. S. Savings Bonds to thank! I'll always buy bonds—it's the world's best way to save money!"

Mrs. Callon's story can be your story, too!

What Mary Callon did, you can do, too—and just as easily! Take these three steps today:

1. Decide to put savings first, before you even draw your pay.
2. Decide to save a regular amount systematically.
3. Today—start saving automatically by signing up in the Payroll Savings Plan where you work or the Bond-A-Month Plan where you bank. If you can set aside just \$7.50 weekly, in 10 years you'll have \$4,329.02 cash!

You'll be providing security for yourself, your family, and the free way of life that's so important to us all.

For your security, and your country's too, SAVE NOW—through regular purchase of U.S. Savings Bonds!



Your government does not pay for this advertisement. It is donated by this publication and Foote, Cone & Belding in cooperation with the Advertising Council and the Magazine Publishers' of America.

STOP

FREE SURVEY: Place your rust problems in the hands of a RUST-OLEUM specialist. He will survey your plant for all rust problems, submit detailed recommendations, and make specific tests.

You can stop rust with RUST-OLEUM! An exclusive formula proved in a wide range of industrial and marine applications for more than 25 years. Its tough, pliable film dries to a firm rust-resisting coating that protects against rust—cuts maintenance costs—adds years of use to many metal surfaces, indoors and outdoors.

RUST-OLEUM may be applied over rusted surfaces without removing all the rust, assuring substantial savings in preparation time... It is only necessary to remove all the rust scale and loose rust.

Prompt delivery from Industrial Distributor stocks in principal cities. See *Sweets* for complete catalog and nearest source of supply, or write for complete literature on your company letter head today!

Beautifies AS IT PROTECTS

Available in many
COLORS,
aluminum and white



RUST

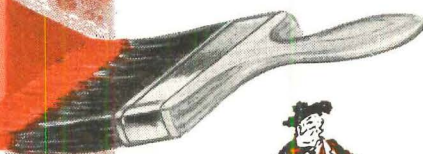

RUST-OLEUM CORPORATION

2501 Oakton Street, Evanston, Illinois

"Rigid Economy, Mon"

DURALL[®] SCREENS

the fastest, most economical way
to give your houses
fine quality screens!



REPLACEMENT OR A REFUND OF MONEY
Guaranteed by
Good Housekeeping
IF NOT AS ADVERTISED THEREIN

	<p>SNAPS INTO PLACE FROM INSIDE! Flick of a finger installs Durall. No ladder climbing, no side frames to cut.</p>		<p>ROLLS UP FOR STORAGE! Durall swings free for window washing, rolls up compactly for easy storage.</p>
	<p>ALUMINUM! NO RUST AND NO PAINTING! Durall keeps its good looks, will not rust or stain house.</p>		<p>GOOD LOOKING AND SNUG-FITTING! Durall stays taut and trim—always keeps out insects permanently!</p>

DURALL Tension Screens are made by one of the oldest manufacturers of wire screening. For complete information, write the New York Wire Cloth Co., Dept. AF-1, 445 Park Avenue, New York 22, New York.

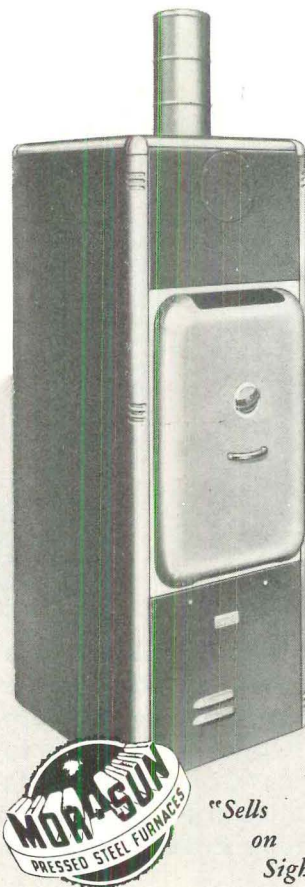

The New Trend!

MOR-SUN RADIANT WARM AIR HEATING

For the increasingly popular Radiant Warm-Air Heat in slab homes in Perimeter or Spider design, MOR-SUN has developed the Counter-Flow model for Gas and Oil...for installation in basementless houses, utility rooms, closets, alcoves or recesses.



"Sells on Sight"

WRITE for details and specifications!



MOR-SUN Furnace Division
MORRISON STEEL PRODUCTS, INC.

645 AMHERST ST. • BUFFALO 7, N. Y.

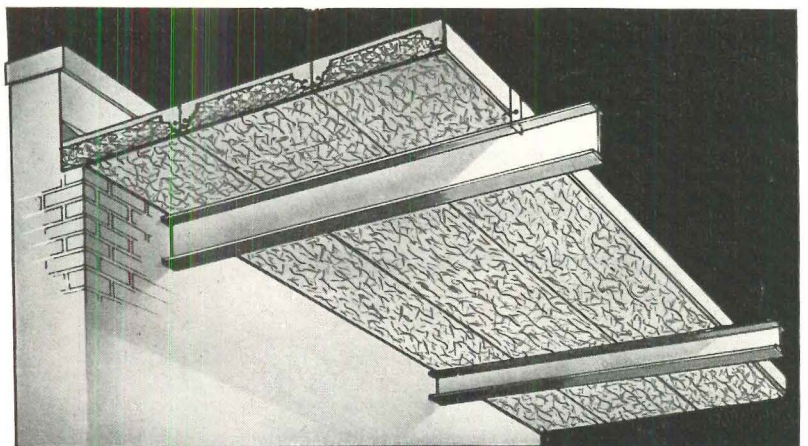

Insulating • Acoustical • Structural ROOF DECKS

- For variable spans up to 8 feet
Nailable concrete surface provided on sloping roofs
- Heat insulation equivalent to 2 inches of cork
Eliminates separate roof insulation
Coefficient of Heat Transmission (U) = 0.16 Btu
- Good sound insulation and absorption
Efficient and economical, exposed acoustical ceiling

Typical Installations

SCHOOLS— Auditoriums, Gymnasiums, Classrooms
CHURCHES • THEATRES
COMMERCIAL AND INDUSTRIAL BUILDINGS

PORETE MFG. CO. North Arlington, N. J.

NEW IDEA

for modern interior designing —

MICARTA in the living room and dining room! For instance, here Micarta is used on the top of a Counter-Wall, which separates two rooms without destroying spaciousness. It is functional . . . and especially handsome because Micarta is made in the unique Decorator Colors (earthy pastels) and Truwoods (real wood veneers).



As seen in the Woman's Home Companion — Museum of Modern Art exhibition house

WESTINGHOUSE

MICARTA®

is a budget-controlled "extra" that sells houses.

Micarta offers every advantage of a top quality plastic laminate plus unique colors and patterns. It has the amazing cleanability and durability wanted in kitchens, playrooms and bathrooms—plus the subtle beauty wanted in living rooms and dining rooms. And . . .

YOUR CARPENTERS CAN INSTALL MICARTA

Micarta fits right in your operation — because the new Micarta Panels can be installed by your crew the same way you install any wood or plywood panel. They are 7/8" panels (1/16" Micarta fused to 3/4" Weldwood Plywood) and they can be sawed, drilled, trimmed and installed with inexpensive hand or power tools.

learn all the details—mail this coupon—



Manufactured by
WESTINGHOUSE

and sold in decorative grades only by
UNITED STATES PLYWOOD CORPORATION
and **U. S. - MENGEL PLYWOODS, INC.**

UNITED STATES PLYWOOD CORPORATION M-O-B. 1-51
55 West 44th Street, New York 18, N. Y.

Please send free Micarta testing sample and complete data.

NAME _____

COMPANY _____

ADDRESS _____

CITY _____ STATE _____

Over
7 MILLION SQUARE FEET OF

KAYLO
 INSULATING
ROOF TILE
 ... Placed in the 2¹/₂ Years
 Since its Introduction



EASY APPLICATION of Kaylo Insulating Roof Tile expedites the completion of flat or pitched roofs. Standard roofing materials are used over a Kaylo roof deck.



Kaylo Insulating Roof Tile is selected for more and more buildings of all kinds because it offers a combination of advantages unmatched by any other roof deck material:

- Incombustibility** of Kaylo Tile assures protection against fire;
- Insulating Value** eliminates the need for additional insulating materials under all but severe conditions;
- Structural Strength** is more than adequate for typical roof loads;
- Light Weight** permits the use of lighter supporting structural members;
- Inorganic Composition** resists rot—moisture does not damage Kaylo Insulating Roof Tile.

It will pay you to investigate these advantages.

KAYLO ... FIRST IN CALCIUM SILICATE
 ... pioneered by

OWENS-ILLINOIS GLASS COMPANY
 Kaylo Division • Toledo 1, Ohio

SALES OFFICES: Atlanta • Boston • Buffalo • Chicago • Cincinnati • Cleveland • Detroit
 Houston • Minneapolis • New York • Oklahoma City • Philadelphia
 Pittsburgh • St. Louis • Washington

SEND COUPON FOR KAYLO ROOF TILE LITERATURE!

OWENS-ILLINOIS GLASS COMPANY
 Kaylo Division, Dept. N-115 • Toledo 1, Ohio

Gentlemen: Please send me literature on Kaylo Roof Tile.

NAME

FIRM

ADDRESS

CITY STATE



YOU CAN BE **SURE**.. IF IT'S
Westinghouse

REFLECTED GLARE

**causes blind spots...
eyestrain... fatigue...
spirits droop... And you
have a lighting
problem!**

Why is this hard to read?

You can see at a glance why this makes reading difficult. It creates a real teaching problem for you—a lighting problem for us. It takes more than a luminaire to solve this problem. It takes the right equipment, certainly. It also takes expert planning in the application of this

equipment *to give you the best buy in lighting.*

Westinghouse offers both. A choice of equipment . . . to do the job *and qualified engineering service.* This means men who know how to apply this equipment for *your* individual lighting problem.

J-04284

Whether you plan lighting, buy lighting or install lighting, this book should be on your desk. "The ABC Plan for School Lighting," B-4556. Write Westinghouse Electric Corporation, P. O. Box 868, Pittsburgh 30, Pennsylvania.

Westinghouse
PLANNED
LIGHTING
PAYS

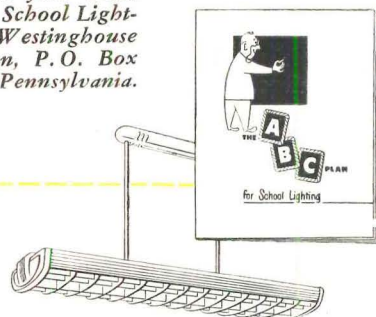

THESE BUILDINGS *



PROTECTED

BY TOCH

R.I.W.
SINCE 1848

DAMP PROOFING

WATER PROOFING

FLOOR TREATMENTS

PROTECTIVE COATINGS

TECHNICAL PAINTS

Important design and construction deserve superior protection against the deteriorating effects of time and weather. For this reason, leading architects and builders choose Toch R.I.W. protective products. Made of scientifically compounded ingredients, the R.I.W. line has proven for over a century, its special ability in adding longer life and better appearance to all types of surfaces. On your next project, specify R.I.W., made by Toch Bros.

*

The buildings shown are a few of the noted structures which comprise Toch City. Numerous such buildings have been protected through the years by R.I.W. products.

TOCH BROTHERS, INC.
NEW YORK CHICAGO

SPECIFICATION AND

The advertising pages of The Magazine of BUILDING are the recognized market place for those engaged in building. A house or any building could be built completely of products advertised here. While it is not possible to certify building products, it is possible to open these pages only to those manufacturers whose reputation merits confidence.

Alberene Stone Corporation.....	182
American Air Filter Company, Inc. (Herman Nelson Division)	34
American Brass Company, The.....	175
American Central Division (Avco Manufacturing Corp.).....	249
American Chemical Paint Company.....	248
American Iron & Steel Institute (Committee on Steel Pipe Research)	200
American-Olean Tile Company.....	225
American Radiator & Standard Sanitary Corporation.....	203
American Structural Products Company (Subsidiary of Owens-Illinois Glass Company)	196
American Telephone & Telegraph Company.....	222
American Welding & Manufacturing Co., The.....	188
Andersen Corporation.....	150, 151
Anthracite Institute.....	208
Armstrong Cork Company.....	45, 246, 247
Auto-Lok Aluminum Awning Windows (Ludman Corp.)...26, 27	
Avco Manufacturing Corporation (American Central Division)	249
Avco Manufacturing Corporation (Crosley Division).....	172, 173
Avco Manufacturing Corporation (Lycoming-Spencer Div.)..	217
Bakelite Division (Union Carbide and Carbon Corp.).....	159
Bolta Company, The.....	257
Bradley Lumber Company of Arkansas.....	19
Briggs Manufacturing Co.....	Bet. 192 & 193
Brikcrete Associates, Inc.....	220
Bruce, E. L., Co.....	2
BullDog Electric Products Company.....	245
Bundy Tubing Company.....	243
Cabot, Samuel, Inc.....	230
Cambridge Tile Manufacturing Company, The.....	Cover II
Carr, Adams & Collier Company.....	59
Case, W. A., & Son Mfg. Co.....	10
Ceco Steel Products Corporation.....	178, 179
Chicopee Manufacturing Corporation.....	152
Committee On Steel Pipe Research (American Iron & Steel Institute)	200
Concrete Reinforcing Steel Institute.....	58
Connor, W. B., Engineering Corporation.....	190
Corning Glass Works.....	20
C-O-Two Fire Equipment.....	199
Couch, S. H., Company, Inc.....	234
Crane Co.....	168
Croft Steel Products, Inc.....	232
Crosley Division (Avco Manufacturing Corporation)	172, 173
Curtis Co.....	64
Deco Sales Division (U. S. Plywood Corp.).....	157
Delaware Floor Products, Inc.....	41
Delco Appliance Division (General Motors Corp.).....	223
Dodge Cork Co., Inc.....	232
Douglas Fir Plywood Association.....	194, 195
Dunham, C. A., Company.....	60
Eljer Company.....	Cover III
Emerson Electric Mfg. Co., The.....	156
Facing Tile Institute.....	181
Fair Lumber Co., D. L.....	228
Fiat Metal Manufacturing Company.....	148
Fitzgibbons Boiler Co., Inc.....	55
Formica Company, The.....	260
Frigidaire Division (General Motors Corporation)	18

BUYING INDEX

General Electric Company.....	187, 238, 239, 240, 241
General Industries, Inc.....	224
General Motors Corp. (<i>Delco Appliance Division</i>).....	223
General Motors Corporation (<i>Frigidaire Division</i>).....	18
General Portland Cement Co. (<i>Trinity Division</i>).....	48
Getty, H. S. & Co., Inc.....	186
Grand Rapids Store Equipment Co.....	234
Granite City Steel Company.....	40
Graybar Electric Co.....	206, 209
Great Lakes Steel Corp. (<i>Stran-Steel Division</i>).....	227
Gustin-Bacon Manufacturing Co.....	231
Hachmeister-Inc.	176
Hager, C., & Sons Hinge Mfg. Co.....	204
Hall-Mack Company.....	165
Harnischfeger Corp.....	37, 38, 39
Hauserman, E. F. Company, The.....	16
Higgins, Inc.	160
Holcomb & Hoke Mfg. Co., Inc.....	56
Homasote Company.....	207
Hood Rubber Company.....	193
Hope's Windows, Inc.....	70
Hotpoint, Inc.	14, 15
House & Garden.....	201
In-Sink-Erator Manufacturing Company.....	192
Insulite Division (<i>Minnesota and Ontario Paper Co.</i>)	191, 228
International Steel Company.....	242
Jamestown Metal Corporation.....	234
Johns-Manville	214, 215
Jones & Brown.....	184
Jones & Laughlin Steel Corporation.....	167
Kawneer Co., The.....	30, 31
Kaylo Division (<i>Owens-Illinois Glass Co.</i>).....	254
Kelvinator Division (<i>Nash-Kelvinator Corp.</i>).....	8
Kennedy, David E., Inc.....	4, 5
Kewanee Boiler Corporation.....	34
Kitchen Maid Corporation, The.....	244
Kohler Company.....	213
Kwikset Locks, Inc.....	1
Leader Electric Manufacturing Corporation.....	237
Libbey-Owens-Ford Glass Company.....	44, 197
Ludman Corp. (<i>Auto-Lok Aluminum Awning Windows</i>)... ..	26, 27
Ludowici-Celadon Company.....	236
Lycoming-Spencer Division (<i>Avco Manufacturing Corp.</i>)....	217
Magazine of BUILDING.....	221
Malta Mfg. Co., Inc., The.....	248
Mastic Tile Corporation of America.....	65
Mengel Company, The.....	11, 180
Miller Company, The.....	22
Mills Company, The.....	229
Minneapolis-Honeywell Regulator Company.....	46, 47
Minnesota and Ontario Paper Co. (<i>Insulite Division</i>)....	191, 228
M and M Wood Working Company.....	68, 69
Modine Manufacturing Company.....	211
Monsanto Chemical Co.....	24
Morrison Steel Products, Inc.....	252
Murphy Door Bed Co.....	232
Nash-Kelvinator Corp. (<i>Kelvinator Division</i>).....	8
National Association of Home Builders.....	250
National Electrical Manufacturers Association.....	32, 185
National Electric Products Corporation.....	169

HOW TO MAKE FRIENDS



Crossroads Restaurant, Miami Beach, Florida. Upholstered in Boltaflex by Leathercraft Upholsterers, Miami, Florida. Installations by Bramlett Equipment Co., Miami, Florida.

..and influence people to come back!

Boltaflex says, "Welcome, Friend!" to every diner-outer at the smartest spots in Miami Beach, and its chic, gay beauty brings people back again and again for their pleasure and "Mine Host's" profit . . . further, it wears so well and washes so easily that overhead and upkeep become almost forgotten words. These are the reasons that have put Boltaflex installations in the most popular and beautiful resorts and restaurants, homes and hotels from coast to coast. This year, in addition to the Boltaflex gorgeous designs and finishes you have seen before, we offer the most exciting new brocade and damask effects you ever dreamed of in the new Boltaflex Textelle. Send for swatches and details. Dept. Y-1.

BOLTA PRODUCTS SALES, INC.
Lawrence, Massachusetts

Branch Offices and Warehouses: New York, 45 West 34th St.; Chicago, Space 211 American Furniture Mart; High Point, N. C., 513 English St.; Philadelphia, 230 Arch St.; Los Angeles, 3544 East Olympic Blvd.

Boltaflex means
Lasting
Covered with Beauty*

*ALL-PLASTIC MATERIAL



Boltaflex is also available in **SEALTUFT**, the stitchless, quilted plastic.

This
SCHLAGE[®]
 button started
 a revolution

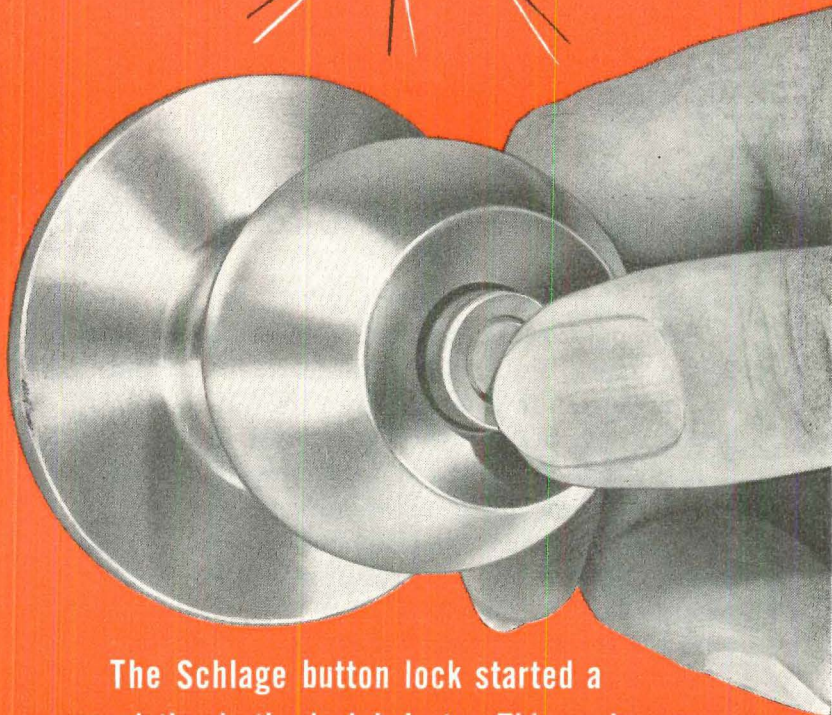

The Schlage button lock started a revolution in the lock industry. This push-button lock was invented over 25 years ago by Walter Schlage. Today it is the accepted and preferred type of lock mechanism ... the first basic improvement in lock engineering in centuries.

SCHLAGE[®]

SCHLAGE LOCK COMPANY

2201 Bayshore Blvd.
 San Francisco

Empire State Bldg.
 New York

SPECIFICATION AND BUYING INDEX

National Gypsum Company.....	149
National Homes Corporation.....	66
Nelson, Herman, Division of American Aid Filter Co., Inc... 34	
New Castle Products.....	52
New York Wire Cloth Co.....	252
Niagara Blower Co.....	166
Norma Pencil Corp.....	216
Norton Co.....	216
Ohio Can & Crown Company.....	164
Overhead Door Corporation.....	Cover IV
Owens-Illinois Glass Co. (<i>American Structural Products Company, Subsidiary</i>).....	196
Owens-Illinois Glass Co. (<i>Kaylo Division</i>).....	254
Paine Lumber Co.....	63
Peelle Company, The.....	Opp. 192
Pittsburgh Plate Glass Company.....	50, 51
Pittsburgh Reflector Company.....	219
Pittsburgh Steel Products Company.....	57
Porete Mfg. Co.....	252
Pryne & Company, Inc.....	49
Raymond Concrete Pile Company.....	161
Revere Copper and Brass, Inc.....	153
Reznor Manufacturing Co.....	224
Roddis Plywood Corp.....	54
Rowe Manufacturing Company.....	147
R.O.W. Sales Company.....	171
Ruberoid Company, The.....	189
Russell, F. C., Company, The.....	163
Rust-Oleum Corporation.....	251
Sanymetal Products Co., Inc., The.....	71
Sargent & Company.....	244
Schieber Mfg. Co.....	36
Schlage Lock Company.....	258
Scott Paper Company.....	155
Sedgwick Machine Works, Inc.....	230
Shepard Elevator Co.....	228
Simpson Logging Company.....	23
Sloan Valve Company.....	Opp. 193
Soss Mfg. Co.....	62
Standard Dry Wall Products, Inc.....	210
Stanley Works, The.....	233
Stewart-Warner Corporation.....	170
Stran-Steel Division (<i>Great Lakes Steel Corp.</i>).....	227
Superior Combustion Industries, Inc.....	183
Taylor, Halsey W., Company, The.....	248
Timber Structures, Inc.....	259
Timken Silent Automatic Division (<i>The Timken-Detroit Axle Co.</i>).....	53
Toch Bros., Inc.....	256
Trane Company, The.....	42, 43
Trinity Division (<i>General Portland Cement Co.</i>).....	48
Truscon Steel Company.....	158
Tuttle & Bailey, Inc.....	67
Union Carbide and Carbon Corporation (<i>Bakelite Unit</i>).....	159
United States Plywood Corporation.....	72, 218, 253
United States Plywood Corporation (<i>Deco Sales Division</i>).....	157
United States Saving Bonds.....	250
United Steel Fabricators, Inc.....	162
Uvalde Rock Asphalt Company.....	202
Virginia Metal Products Corp.....	33
Vonnegut Hardware Company, Von Duprin Division.....	6, 7
Wakefield, F. W., Brass Co., The.....	154
Walworth Company.....	226
Wasco Flashing Company.....	177
Waterman-Waterbury, Co., The.....	28
Waylite Co.....	198
Westinghouse Electric Corporation.....	61, 235, 255
Wood-Mosaic Co., Inc.....	212
Worthington Pump and Machinery Corporation.....	12
Zonolite Company.....	205

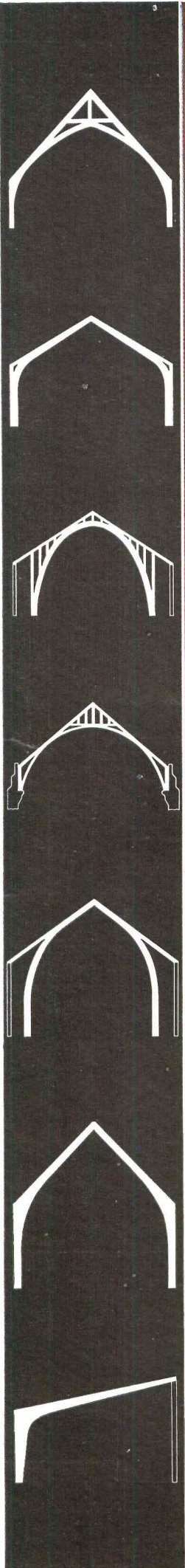

PIETRO BELLUSCHI, F.A.I.A.

Glued Laminated Cathedral Arches

...a functional application of a beautiful material

THE PICTURE ABOVE tells its own story of the beauty of the glued laminated cathedral arches of Timber Structures, Inc. It shows, too, the functional construction which not only provides the architectural motif, but also gives the congregation a better and more beautiful church at a substantial saving in cost.

Arches spring from the foundations. Simply finished they impart beauty and dignity along with roof and wall support. Curtain walls of eight inch thickness proved to be sufficient. This composite construction was found to save \$60,000 over the contractor's estimate for a building of equal size and capacity designed for bearing wall construction.

A new booklet, "Engineered Timbers", gives detailed information about glued laminated members, and a copy is yours for the asking. See your nearest Timber Structures office, or use the coupon below.

TIMBER STRUCTURES, INC.

P. O. BOX 3782-B, PORTLAND 8, OREGON

Sales offices in New York; Chicago; Kansas City, Missouri; Dallas, Texas; Eugene, Oregon; Seattle and Spokane, Washington

TIMBER STRUCTURES, INC. OF CALIFORNIA • Oakland

TIMBER STRUCTURES OF CANADA, LTD. • Peterborough, Ontario

Local Representatives Coast to Coast

TIMBER STRUCTURES, INC.

P. O. Box 3782-B, Portland 8, Oregon

Please send a copy of booklet, "Engineered Timbers" to

Name _____

Company Name _____

Address _____

City _____ Zone _____ State _____

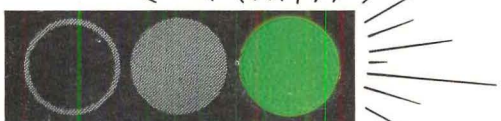
How **FORMICA**
Reg. U. S. Pat. Off.
 helps keep the
Traffic Light

GREEN...

Millions of dollars worth of profitable human traffic flows through four famous midwestern hotels operated by the Schimmel brothers. In restaurants, bars, elevators, and lobbies — wherever there are surfaces exposed to extra hard use, there you will find Beauty Bonded Formica. In wood grains or color patterns Formica fits well the slogan of their Hotel Lassen in Wichita — “Ever-LASSEN-ly Yours.” Formica has been proving its beauty and practicality in the nation’s most famous hotels for more than 30 years.



Illustrations from Hotel Custer, Galesburg, Ill.
 Formica installed by Iowa Plastic Fabricators, Denison, Iowa.

For samples of
 Beauty Bonded Formica
 and more complete
 information write

Beauty Bonded
FORMICA
Reg. U. S. Pat. Off.
 at Home with People
 at Work in Industry

REPLACEMENT OR REFUND OF MONEY
 GUARANTEED BY
 Good Housekeeping
 IF NOT AS ADVERTISED THEREIN

FORMICA

4631 Spring Grove Avenue, Cincinnati 32, Ohio



ELJER

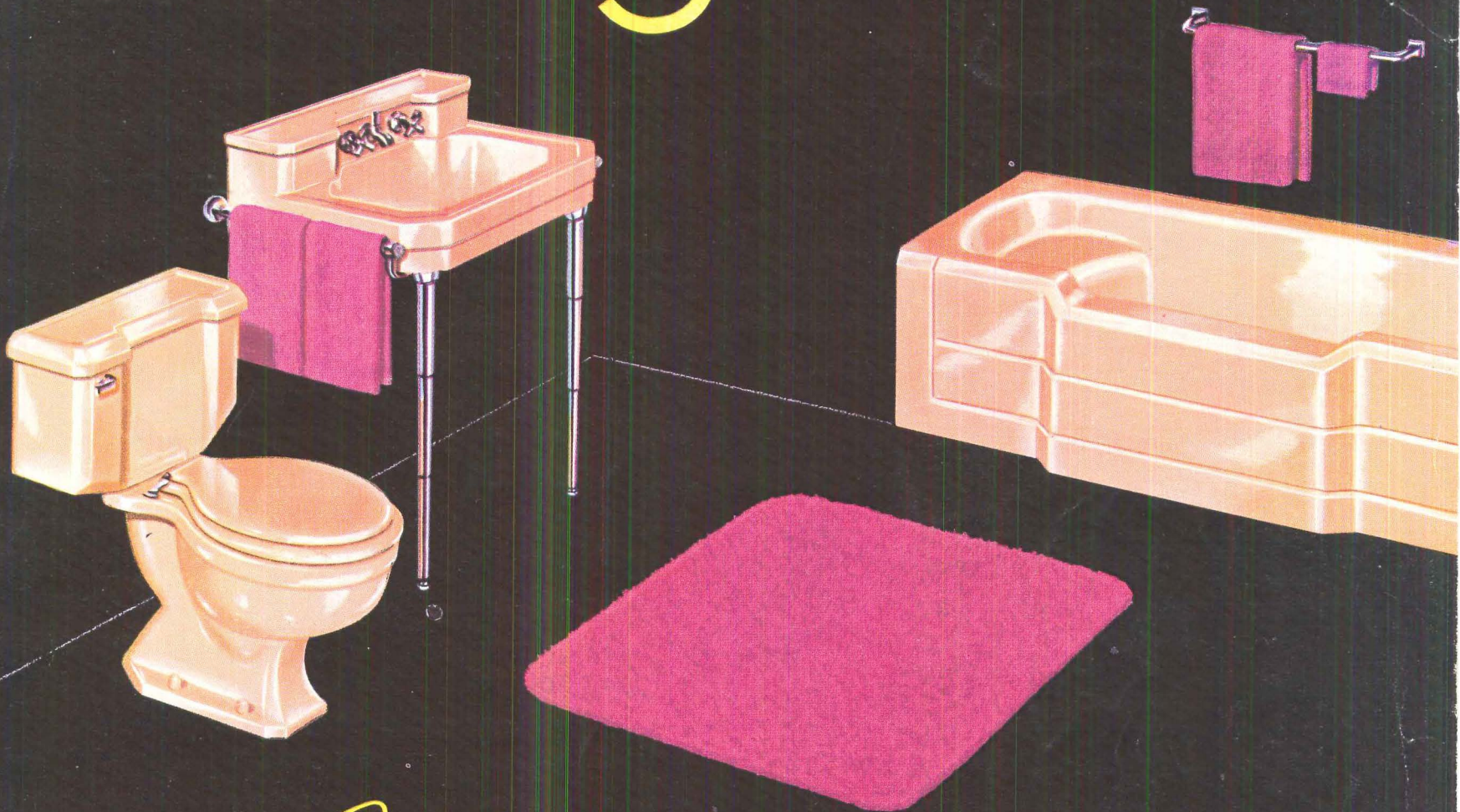

Color

STARTS IN THE PLANNING

If you want a bathroom that excites admiration, architects and builders will suggest that you use colored plumbing fixtures. We suggest that you specify Eljer . . . in one of our soft, pastel colors that make it easy to have whatever decorative scheme you want. You *will* get quality . . . because Eljer colors *cannot* fade, become dull or lifeless. Bathtubs have an extra-thick finish that is fused to a *rugged, rigid cast-iron* base. Vitreous China Lavatories and Closet Combinations resist stains and are impervious to all acids . . . because they are *real china*. And, you'll find the clean and keep clean . . . with just the swish of a damp cloth.

Write Eljer's Colored Plumbing Fixtures into your plans.



Ask your plumbing contractor, builder or architect to help you select the exact combination of fixtures you want for bathroom, powder room, kitchen or laundry . . . and for helpful ideas on the use of color, write Eljer Co., Box 192, Ford City, Penna.

12 MILLION PLUMBING FIXTURES SINCE 1904 . . . FACTORIES AT FORD CITY, PA., SALEM AND MARYSVILLE, OHIO

Advertisements like this will give millions of readers of The Saturday Evening Post an increasing appreciation of the quality and beauty of Eljer's Fine Plumbing Fixtures . . . and some of them will be your clients.

1951

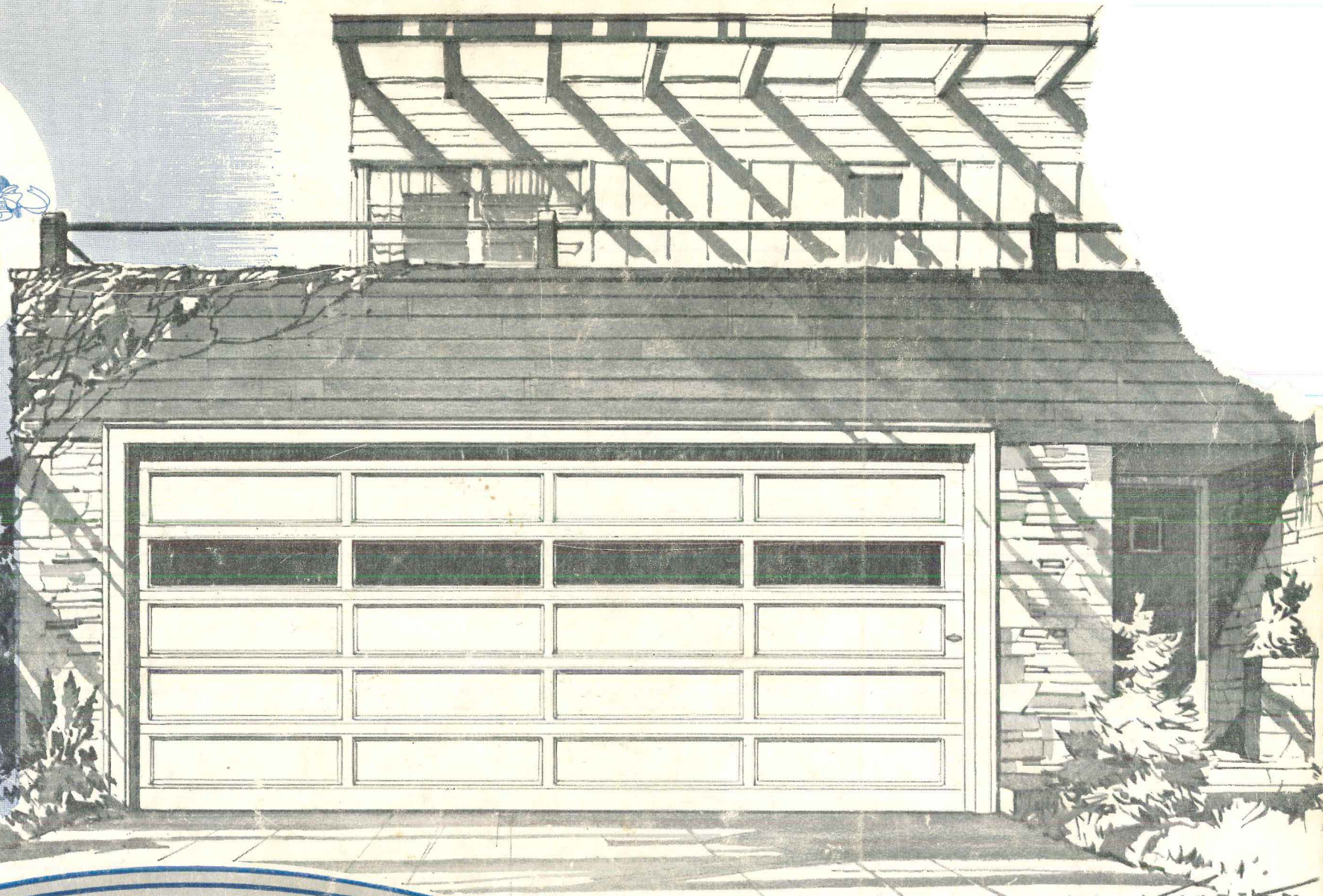

THE

"OVERHEAD DOOR"

TRADE MARK

OVERHEAD DOOR CORPORATION

Hartford City, Indiana, U. S. A.

MANUFACTURING DIVISIONS

GLENDAL, CALIFORNIA
OKLAHOMA CITY, OKLAHOMA

DETROIT, MICHIGAN
PORTLAND, OREGON

HILLSIDE, NEW JERSEY
LEWISTOWN, PENNSYLVANIA

CORTLAND, NEW YORK
DALLAS, TEXAS

To our many friends — and to the many more The "OVERHEAD DOOR" will make in the coming year — our sincere wish for security, prosperity and peace.



COPYRIGHT 1950 " OVERHEAD DOOR CORPORATION