

ALAN JOURNAL

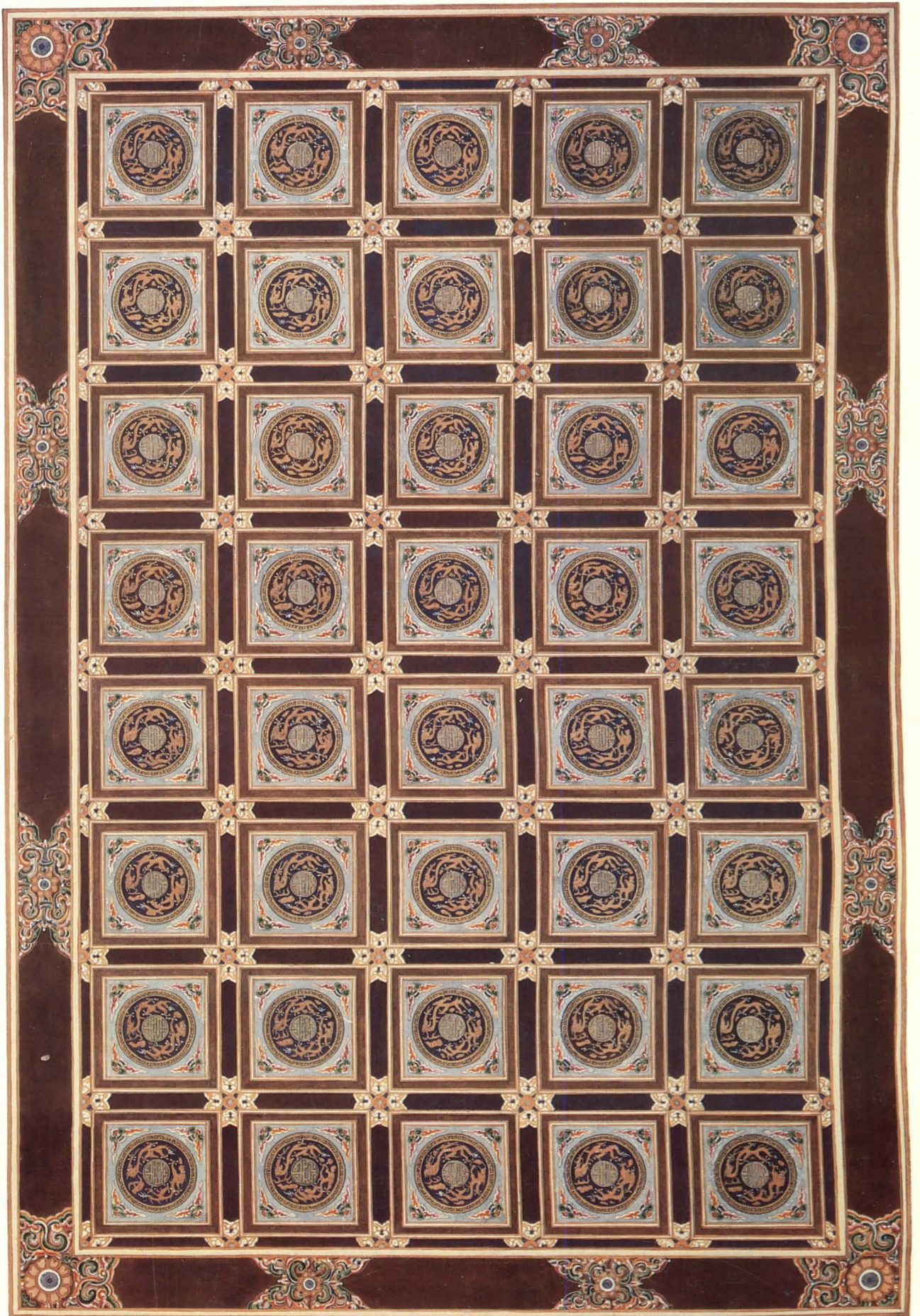

Thermal Overwear.



It's Howmet's HP-1175 sloped wall system – the most exciting way to top off a good design, yet. Featuring improvements in energy efficiency, structural engineering and overall architectural beauty.

You won't find a sloped wall system with a better thermal isolation factor. The HP-1175 utilizes heavy duty non-conductive injection molded clips to shield the transference of heat and cold.



Plus it has a unique internal gutter system which reroutes condensation to the outside and requires no exterior caulking. This adds years of product performance by avoiding exposure of the sealant to weather conditions.

In addition, the HP-1175 can be anchored directly to vertical wall systems to provide dimensional continuity and uniform expansion.

The HP-1175 is a designer's dream. You can create a variety of different "looks" with a choice of three beautiful finishes: bronze, black or clear aluminum.

And you can choose from a wide range of infill and glazing thicknesses.

To round out a good design, we made the HP-1175 easy to work with. It can be installed in units, ensuring ease of installation and proper daylight openings. And since we keep it stocked in inventory, it's available in standard lengths to meet most job requirements.

So, the next time you specify a sloped wall system, remember Howmet. We make the best thermal overwear in the business.

For more information call (214) 563-2624. Or write: Howmet, Architectural Products Division, P.O. Box 629, Terrell, Texas 75160.

HOWMET **HOWMET**
ALUMINUM
CORPORATION

A Member of the Pechiney Ugine Kuhlmann Group

Howmet. The name to remember.

Circle 1 on information card

Why did the new Atlanta Airport choose gas air conditioning? Pure economics.



Architects, Engineers and Planners: Stevens & Wilkinson; Smith, Hinchman & Grylls; Minority Airport Architects & Planners.

In the world's largest airport terminal complex, designed to serve over 50 million people a year, air conditioning is a prime consideration.

When Atlanta's engineers examined the systems meeting their specifications, they decided on heat driven equipment as the lowest energy user and the most cost-efficient based on life-cycle analysis.

Their selection was a steam operated turbo-absorption air conditioning system. Designed for future growth, this 7,500 ton system has one of the lowest energy consumption rates per ton hour of cooling available—just 7.8 lbs. of steam per hour. The primary fuel is natural gas.

Since gas offers total system efficiency, the new Atlanta Airport also depends on gas for heating. But not only large-scale buildings can benefit. Gas heating/cooling systems can provide operating economies in smaller buildings as well.

For details on such integrated systems, contact your gas company.



Gas: The future belongs to the efficient.

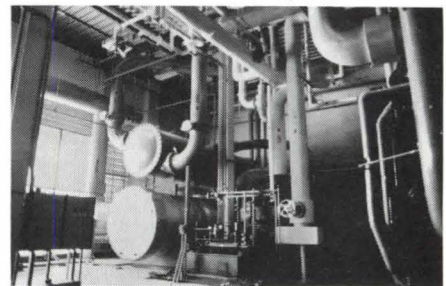

Cooling Equipment: Turbo-Absorption
by York Division, Borg-Warner Corporation.

Circle 2 on information card

A black and white photograph of a hand holding a penny over architectural blueprints. The hand is positioned as if about to drop the coin. The blueprints below show technical drawings with lines and text.

**A penny saved
can cost
you money.**

You may be able to find Professional Liability Insurance Coverage for your architectural or engineering practice for less money, but you won't find a program that works as hard or does as much for you as CNA's Architects' and Engineers' Professional Liability Insurance, administered by Victor O. Schinnerer & Company, Inc.

That's because we've been in the business a lot longer than any other company that provides this type of coverage. We've worked every step of the way with The American Institute of Architects and The National Society of Professional Engineers to develop a program that answers your specific needs. We created the Office for Professional Liability Research to compile data that can help you avoid professional liability claims. We consult on contract liability issues, publish loss prevention articles, conduct seminars, and speak at local and regional chapter meetings. The Schinnerer/CNA program has a staff of claims specialists across the country waiting to assist you.

And that's only part of the story. Ours is the most comprehensive professional liability insurance program available, with special features like the Deductible Credit Plan, First Dollar Defense Cost Coverage and Fully Retroactive Coverage.

So when you're looking for Professional Liability Coverage, don't forget to check what you're getting for your money. What you give up to save a little now could cost you a lot later.

The CNA Architects' and Engineers' Professional Liability Program is commended by the American Institute of Architects and the National Society of Professional Engineers PEPP.

Victor O.

Schinnerer
& Company, Inc.

The First Is Still The Best

Program Administrators
& Underwriting Managers

Ask your broker for details.

Circle 3 on information card

5028 Wisconsin Ave., N.W.
Washington, D.C. 20016
Phone: (202) 686-2850

40 Wall Street
New York, N.Y. 10005
Phone: (212) 344-1000

55 E. Jackson Boulevard
Chicago, Illinois 60604
Phone: (312) 939-1202

595 Market Street
San Francisco, CA 94105
Phone: (415) 495-3444

CONTENTS

The American Institute of Architects

Officers









R. Randall Vosbeck, FAIA, *President*
Robert M. Lawrence, FAIA, *First Vice President*
Robert Broshar, FAIA, *Vice President*
George M. Notter Jr., FAIA, *Vice President*
Ray K. Parker, AIA, *Vice President*
Harry W. Harmon, FAIA, *Secretary*
J. W. Barnes, FAIA, *Treasurer*
David Olan Meeker Jr., FAIA, *Executive Vice President*

Directors (Year indicates expiration of term)

George A. Bissell, FAIA ('83), *California*
William Blurock, FAIA ('82), *California*
James C. Dodd, AIA ('81), *California*
J. Peter Winkelstein, FAIA ('83), *California*
R. Bruce Patty, FAIA ('82), *Central States*
Henry W. Schirmer, AIA ('81), *Central States*
P. Whitney Webb, AIA ('82), *East Central States*
Ellis W. Bullock Jr., AIA ('81), *Florida/Caribbean*
E. H. McDowell, FAIA ('81), *Florida/Caribbean*
William H. Beaty, AIA ('83), *Gulf States*
Gaines B. Hall, AIA ('81), *Gulf States*
Raymond C. Ovsat, FAIA ('81), *Illinois*
John W. Jickling, FAIA ('83), *Michigan*
Theodore F. Mariani, AIA ('83), *Middle Atlantic*
James R. Nelson, AIA ('81), *Middle Atlantic*
John Avery Carter, AIA ('82), *New England*
Robert J. von Dohlen, AIA ('83), *New England*
Romeo Aybar, AIA ('83), *New Jersey*
Joseph Monticciolo, AIA ('82), *New York*
William A. Rose Jr., AIA ('81), *New York*
Leroy Bean, AIA ('82), *North Central States*
Edwin B. Crittenden, FAIA ('81), *Northwest*
David A. Pugh, FAIA ('83), *Northwest*
Robert Gramann, AIA ('82), *Ohio*
Derek Martin, AIA ('81), *Pennsylvania*
John A. Busby Jr., FAIA ('82), *South Atlantic*
Richard A. McGinty, AIA ('83), *South Atlantic*
William Caudill, FAIA ('82), *Texas*
Theodore S. Maffitt Jr., FAIA ('81), *Texas*
Pat Y. Spillman, FAIA ('81), *Texas*
Thomas B. Muths, AIA ('82), *Western Mountain*
John B. Rogers, FAIA ('81), *Western Mountain*
Robert B. Pease, Hon. AIA, *ex officio, Public Director*
William J. Plimpton, *ex officio, President, ASC/AIA*
Ann Stacy, Hon. AIA, *ex officio, Chairwoman, Council of Architectural Component Executives*

Headquarters

David Olan Meeker Jr., FAIA, *Executive Vice President*
James A. Scheeler, FAIA, *Group Executive, Program and Services Management*
Alan B. Stover, AIA, *General Counsel*
James A. Schuping, *Assistant Secretary*
William G. Wolverton, Hon. AIA, *Assistant Treasurer/Controller*
Michael B. Barker, AICP, *Administrator, Design*
Francis X. Brown, *Administrator, Conventions/Conferences/Special Events*
Muriel Campaglia, *Administrator, Public Relations*
James E. Ellison, AIA, *Administrator, Education and Professional Development*
David S. Godfrey, *Administrator, Publications*
Robert T. Packard, AIA, *Administrator, Practice*
Ronald Panciera, *Administrator/Assistant Controller*
Arnold J. Prima Jr., AIA, *Administrator, Government Affairs*
John Wilson-Jeronimo, *Administrator, Member/Component Affairs*
David Olan Meeker Jr., FAIA, *President, AIA Corporation*
Jeanne Butler Hodges, *President, AIA Foundation*
Charles R. Ince Jr., *President, AIA Research Corporation*
John H. Schruben, FAIA, *President, Production Systems for Architects and Engineers, Inc.*

18		The AIA Archives
45		The Basic Workings of the Institute
52		Contacts for Help at AIA
59		Glossary of Acronyms and Abbreviations
69		Directory of AIA Resources (Yellow Pages)
110		Materials Available Through Other Organizations
122		Books, Etc., to Order Through the Institute
136		Sources for AIA Contracts and Forms
144		Resources from Suppliers and Manufacturers
164		Advertisers

Cover: Chinese ceiling design, by the Chu, Chin & Ling Studio, from the AIA Archives (see page 19). Photograph by Wm. Edmund Barrett.

Donald Canty, Editor; **Carole Palmer**, Art Director; **Suzu Thomas**, Associate Art Director; **Stanley Abercrombie**, AIA, Senior Editor, Architecture; **Mary E. Osman**, Hon. AIA, Senior Editor, Books; **Andrea O. Dean**, Senior Editor, Articles; **Allen Freeman**, Managing Editor; **Nora Richter Greer**, Associate Editor; **Lynn Nesmith**, Editorial Assistant; **Michael J. Hanley**, Publisher; **Michael M. Wood**, Director of Marketing; **Jesse Sims**, Production and Business Manager; **Terry L. Peck**, Circulation Manager; **David S. Godfrey**, General Manager.

The AIA JOURNAL, publication number: ISSN0001-1479, official magazine of The American Institute of Architects, is published 14 times yearly at 1735 New York Ave. N.W., Washington, D.C. 20006. **Subscriptions:** for those who are, by title, architects, architectural employees and to those in architectural education (faculty, schools and students), and to libraries, building construction trade associations and building products manufacturers: base rate \$24 a year in the U.S., its possessions and Canada. For all others: \$30 a year in the U.S., its possessions and Canada. All others outside the U.S., its possessions and Canada: \$40 a year. Single copies, \$3 each. Publisher reserves the right to refuse unqualified subscriptions. For subscriptions: write Circulation Department; for change of address: send Circulation Department both old and new addresses; allow six weeks. Quotations on reprints of articles available. Microfilm copies available from University Microfilm, 300 N. Zeeb Road, Ann Arbor, Mich. 48106. Referenced in *The Architectural Index*, *Architectural Periodicals Index*, *Art Index*, *Avery Index to Architectural Periodicals*. Second class postage paid at Washington, D.C., and additional mailing offices. © 1981 by The American Institute of Architects. Opinions expressed by the editors and contributors are not necessarily those of AIA. VOL. 70, NO. 10.

From Main Street...

75 *Kawneer
Years*

It's a Saturday morning, March 10, 1906, in Kansas City, Missouri. As the still fresh 20th Century looks forward to its seventh spring, a young architect sets out to turn a good idea into an industry. Two years earlier, the architect, Francis Plym, had been inspired to invent a revolutionary resilient molding for storefront windows. And on this special day in 1906, the Kawneer Company begins the long journey to its Diamond Jubilee Year. 1981.

Main Street, U.S.A. It was the center of life for turn-of-the-century America. Here, the goods and services of a growing economy were presented to a ready market. And it was on Main Street that the young Kawneer Company made its mark. Francis Plym, Kawneer's founder, saw that the common wood glazing of the time was easily damaged by rain and condensation. His solution was a resilient metal molding which not only lasted longer, but also allowed larger panes of display glass,

necessary for better selling in retail storefront windows.

Soon, Main Streets all over America began to reflect the Kawneer influence. Not only with beautiful, large window areas in stores, but handsome facings and entrances, too. As well as windows, entrances and wall systems in office and public buildings.

From the beginning, the Kawneer Company worked closely with designers, helping them

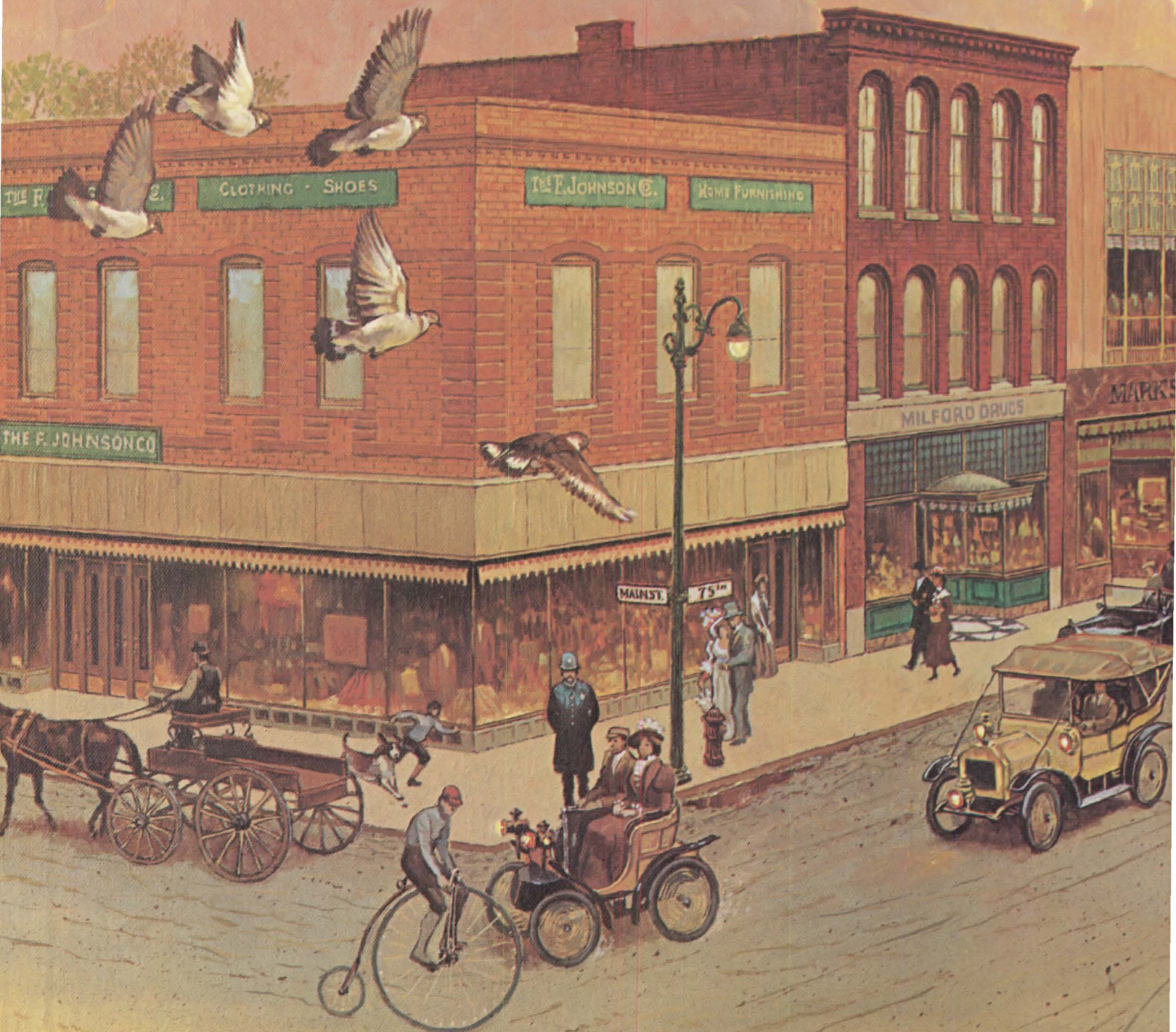

to the Street of Dreams.

express their new designs through the imaginative use of architectural metals. First, in brass. And, in the early 1930's, aluminum.

And on our trip from Main Street, to the countryside, and throughout the world, we at Kawneer have constantly worked to develop the wide range of products necessary to satisfy the needs of designers as they face the demands of their times.

Beyond this year, our 75th Anniversary, is tomorrow, when

the dreams of the present become the landmarks of the future. And knowing this, we at the Kawneer Company take this moment to thank all of our friends for their seventy-five years of support and patronage. But we can spare only a moment. Because, we've got the next seventy-five years to plan for.

Kawneer

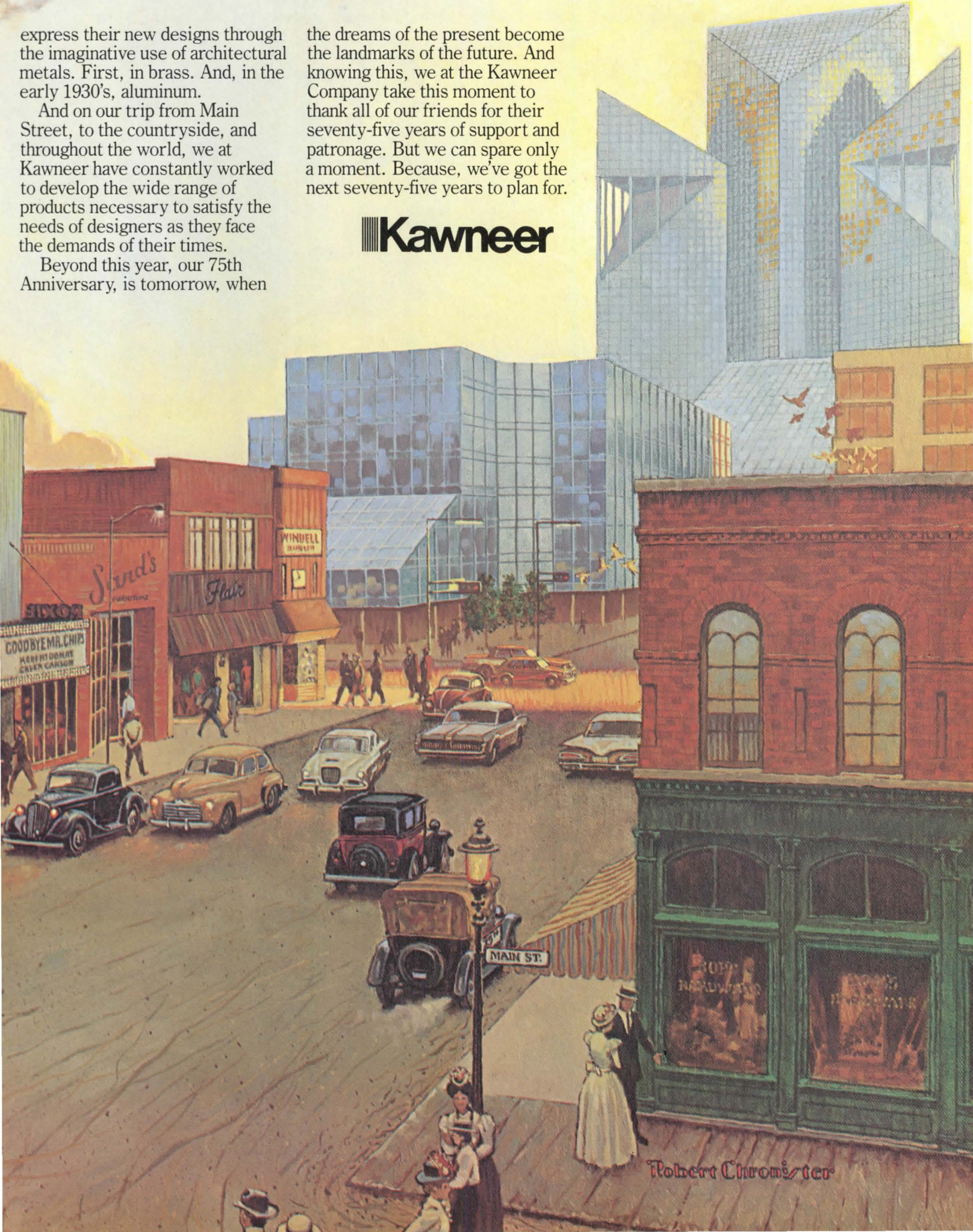

Laminated architectural glass.



For more reasons than meet the eye.

The J. C. Penney Distribution Center is a beautiful example of how laminated architectural glass, with the Saflex® interlayer from Monsanto, can put a combination of features to work in a single glazing.

The design challenge was to combine aesthetics with functionality. Sloped glazing of laminated glass was a natural solution. The sloped design satisfied the aesthetic considerations. And laminated glass answered Penney's concerns about protection from the elements.

For example, a heavy impact may break the glass but the broken fragments will adhere strongly to the Saflex interlayer, which also holds the lite in the frame. Benefits: no dangerous splinters, no falling fragments. And the strength of Saflex also affords a degree of security against break-ins as well as a functional weather barrier.

Another benefit: Saflex laminated to reflective glass produces a combination glazing with superior solar control. And



the reflective coating is protected from abrasion.

Laminated glass also keeps Penney interiors measurably quieter. Provides much better acoustical insulation over the entire sound spectrum than monolithic or airspaced glass.

What more can be achieved by laminated architectural glass?

The Saflex interlayer can be tinted in one of a variety of colors to reduce glare and absorb solar heat. In store windows, a special ultraviolet control laminate protects product displays

against fading. And, laminated glass is especially suited for atriums and skylights, where design also calls for safety and weather protection.

The fact is, laminated architectural glass combines more performance features in a single glazing system than anything you can name.

For a list of leading laminated glass manufacturers, write: Monsanto Plastics & Resins Company, an operating unit of Monsanto Company, Dept. 804, 800 N. Lindbergh Blvd., St. Louis, Missouri 63166.

SAFLEX®

PLASTIC INTERLAYER BY **Monsanto**

Computer output everyone can see

with General Electric Professional Large Screen Video Projection

With General Electric's exclusive system for bright, sharp professional-quality pictures, up to 25 feet wide, General Electric Professional Large Screen Video Projectors are making presentations more dramatic, more productive, and more convenient.

Whether videotape, live transmission, TV programming or data direct from your computer, the pictures projected can be seen by everyone in the room, all at once, even when room lighting is provided so viewers can take notes and refer to written material.

The color projectors show every viewer the same accurate color reproduction. An exclusive General Electric system registers the colors for you, eliminating time-consuming manual adjustments.

Portable and flexible, General Electric projectors are being used in a great variety of applications, including both rear and front projection. Ask our applications experts whether yours can be added to the growing list, which includes:

Education: Medical, dental, engineering, computer science instruction.

Business: Sales meetings, industrial training, product presentations, real-time display of computer-generated data, teleconferences.

Aerospace and Defense: Situation displays, simulator training.

Entertainment: Theatre television, closed-circuit TV events, overflow crowds, special effects.

Television Production: Backgrounds for news programs, special effects, data display, program previewing.

Call or write: General Electric Company, Video Display Equipment Operation, Electronics Park 6-206, Syracuse, NY 13221. Phone: (315) 456-2152.

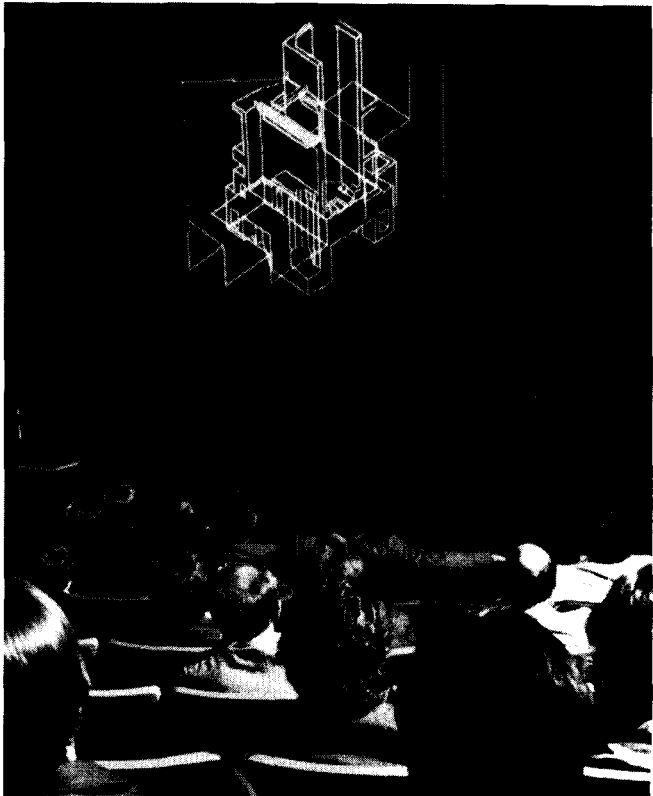

IN ENGINEERING: General Electric projector displays computer-assisted design for Engineering Society of Detroit seminar.

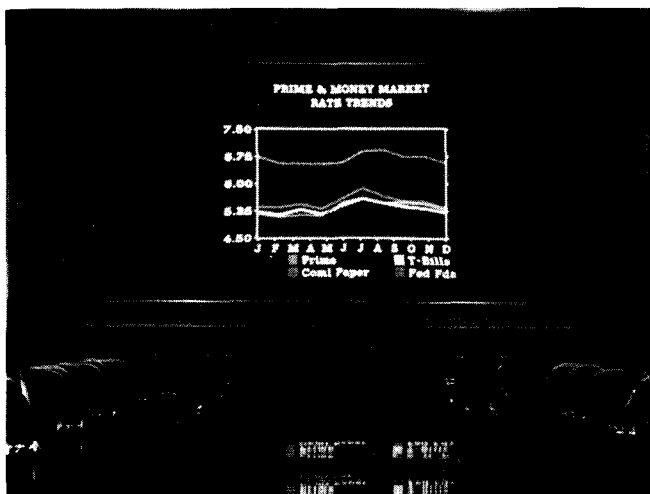

IN THE BOARD ROOM at Mellon Bank, N.A. Pittsburgh, General Electric projector displays data for board review and discussion.

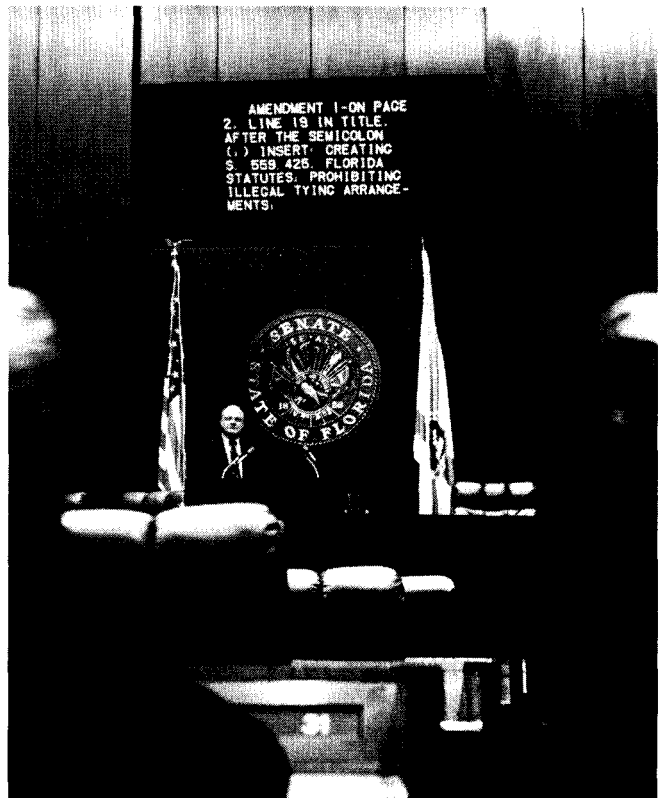

IN GOVERNMENT: General Electric projector displays amendment for Florida State Senate to inspect before voting.

GENERAL  ELECTRIC

Circle 5 on information card

**“ONLY VULCRAFT
COULD HANDLE A JOB
THIS BIG THIS FAST.”**



The new Levi Strauss & Co. Jeanswear Distribution Center is big: 720,000 square feet at a cost of \$19 million and capable of shipping 50 million units a year.

What's more, it had to go up fast. In time for Levi Strauss & Co. to use it to fill summer orders. So a job that typically would be scheduled for 15 months had to be completed in 11 months or less from the time design work started.

The Haskell Company, which designed and constructed the building at Gluckstadt, Mississippi, relished the challenge. And they knew who to turn to for steel joists and joist girders. In their words, "Only Vulcraft could handle a job this big this fast!"

Because Haskell used fast track methods, they specified a precisely timed sequence of deliveries. Vulcraft followed through to perfection. Which didn't surprise Haskell. They had worked with Vulcraft for 15 years, including 20 projects in the previous 30 months.

To find out what the largest joist producer in the country can do for you, talk with your local Vulcraft representative. Or call us at (704) 366-7000. For our steel deck and joist catalogs, write P.O. Box 220646, Charlotte, NC 28222, or see Sweet's 5.2/Vu and 5.5/Vu.

You'll find we can meet your schedule, even if nobody else can.

Circle 7 on information card

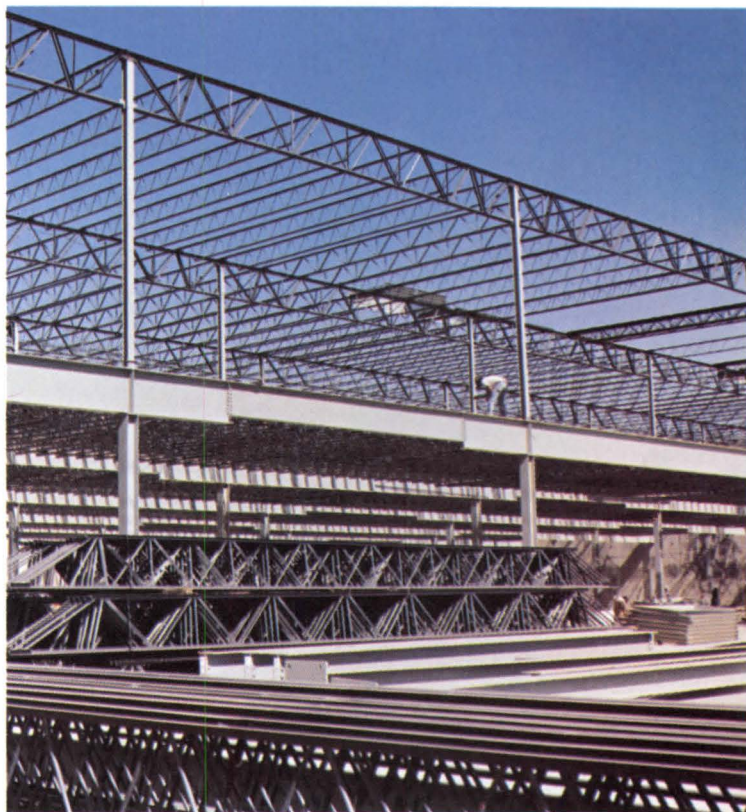

The simplicity and light weight of Vulcraft joists and joist girders make erection faster and easier.

Owner: Levi Strauss & Co.
Architects and Engineers: The Haskell Company
General Contractor: The Haskell Company
Structural Steel Fabricator: Delta Steel Co., Inc.
Steel Erector: Eastern Steel, Inc.

VULCRAFT

A Division of Nucor Corporation

P.O. Box F-2, Florence, SC 29502 803/662-0381
P.O. Box 169, Fort Payne, AL 35967 205/845-2460
P.O. Box 186, Grapeland, TX 75844 713/687-4665
P.O. Box 59, Norfolk, NE 68701 402/371-0020
P.O. Box 1000, St. Joe, IN 46785 219/337-5411

Vulcraft supplied 1,100 tons of joists and 207 tons of joist girders for this Levi Strauss & Co. Distribution Center at Gluckstadt, Mississippi.



MAKE SURE YOUR ROOFING MATERIALS ARE MADE FOR EACH OTHER.

It's a matter of chemistry.

When the materials in your roof are made to go together, your built-up roof will stay together. Resisting the elements that threaten to drive them apart.

That's why our chemists and engineers have developed the GAF Super System. A line of perfectly matched roofing products. With everything from Gaftemp® Isotherm Insulation and Gafglas™ membranes to GAF cements and accessories.

And to be sure they're perfectly matched on your

roof, our technical advisors are standing by. Which ensures our reputation as well.

So call your GAF distributor today.

After all, it's not often you find everything you're looking for all in one person.

For information write GAF Corp., Building Materials, 140 W. 51 St., N.Y., N.Y. 10020, or call toll free 800-223-0344. In N.Y. State call 800-522-5250.



SUPER SYSTEM
PERFECTLY MATCHED BUILT-UP ROOFING
AND INSULATION PRODUCTS.



2" EPS. R = 7.8. 5000 sq. ft.



1" Styrofoam RM. R = 5.0. 3451 sq. ft.

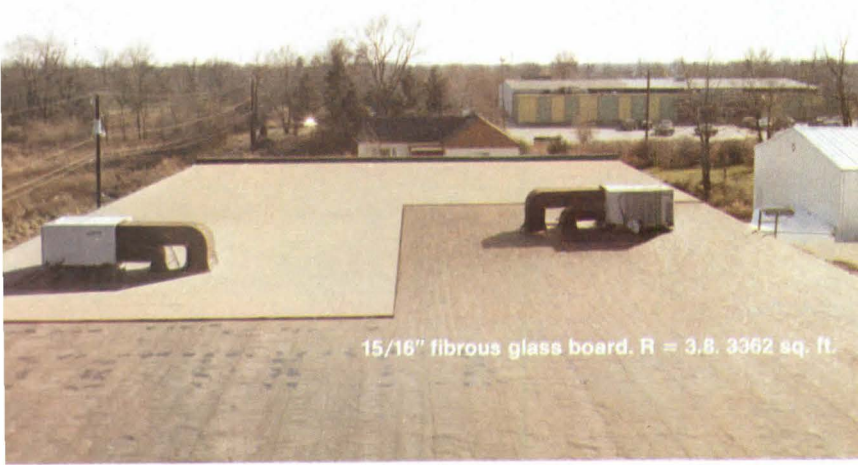

15/16" fibrous glass board. R = 3.8. 3362 sq. ft.



1" urethane foam. R = 6.2. 3095 sq. ft.

ROOF TO ROOF PROOF: YOU GET MORE INSULATION FOR LESS WITH EPS.

Dollar for dollar, you can design more R value into your roofs for less money with EPS (expanded polystyrene) insulation.

Compare for yourself. For the same cost, 2" of EPS covers 49% more area than 1" of Styrofoam RM, 49% more area than 15/16" fibrous glass board, and 62% more than 1" of urethane. And 2" of EPS insulation has a greater R value than any of the other three.

So, the next time somebody recommends an insulation based on a high number of Rs per inch . . . ask about the number of Rs per dollar.

Get more for less with EPS.

MATERIAL	COST/SQ.FT.*	R VALUE	COVERAGE (@ \$1170)
2" EPS	23.4¢	7.8	5000 sq. ft.
1" Styrofoam RM	33.9¢	5.0	3451 sq. ft.
15/16" fibrous glass board	34.8¢	3.8	3362 sq. ft.
1" urethane foam	37.8¢	6.2	3095 sq. ft.

*Estimated average manufacturers' published price per square foot based on a random survey of roofing contractors conducted by the Bureau of Building Marketing Research, November 1980. Actual prices may vary.

Expanded polystyrene (EPS) insulation is combustible and should not be exposed to flame or other ignition source.

Sturdy EPS insulation is available in a variety of densities, configurations, and edge treatments to fit just about any need. For the name of your nearest EPS producer and some design ideas using EPS, call the Sweets Buyline.



ARCO Polymers, Inc.
 Subsidiary of Atlantic Richfield Company
 Pipeline to plastics.
 Manufacturer of DYLITE™ expandable polystyrene.

Circle 9 on information card



NOW! THE CONTRACT CARPET FIBER FOR EXTRA-LONG RESISTANCE

INTRODUCING

ANTRON® XL nylon is the most significant fiber development for contract carpeting since Antron® III. Here is a high-performance BCF fiber that will outperform any other contract carpet fiber. Its amazing soil resistance and strength mean commercial carpeting of Antron® XL will retain its good looks longer with a lot less maintenance.

How does Antron® XL work? It's basically very simple. Antron® XL nylon filaments are bigger than conventional nylon filaments. Therefore, fewer are needed. (See illustrations). This means that in every square yard of carpet, depending on construction, there is 25-30% less surface area to soil. And the less soiling there is, the less-frequent cleaning.

What's more, a larger filament is a more resilient filament. Pile texture retention is greater, so there's less crushing. Even in the most highly trafficked area, Antron® XL makes it possible to install carpeting that will retain its good looks for a long time to come.

You've come to rely on the great performance of Antron® III (with long-term appearance retention and built-in static control). With Antron® XL nylon BCF, you can expect even more—significantly improved soil resistance and pile retention versus all other carpet fibers. That's the latest Antron® Advantage.

Circle 10 on information card

MAN LIFE
MADE: MADE
FIBERS BETTER

**WITH EXTRA-LARGE FILAMENTS
TO SOILING AND CRUSHING.**

ANTRON[®] XL.

**LARGER FILAMENTS PROVIDE
MORE SOIL RESISTANCE AND
RESILIENCE.**

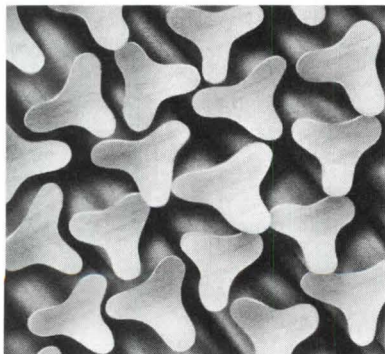
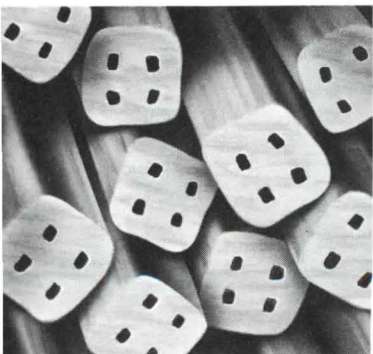

300X. New Antron[®] XL, 34 DPF (BCF).
Total Surface Area: 19,500 cm²/oz.
of face fiber.

300X. "4th Generation" Nylon, 15 DPF
(BCF). Total Surface Area: 26,000 cm²/oz.
of face fiber.

**ANTRON
ANTRON
ANTRON**
THE ANTRON ADVANTAGE



REG. U.S. PAT. & TM. OFF.

There are 2 sides to every fountain

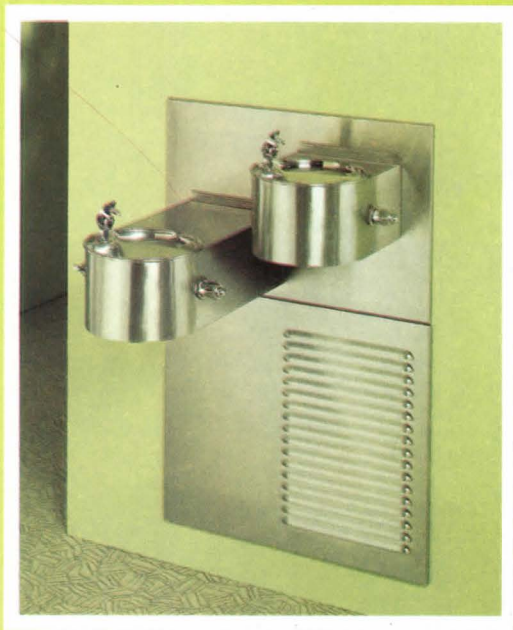

THE SIDE YOU SEE

- Chrome-plated bubblers
- Circular stainless steel receptors
- Self-closing lever valve handles
- Extended receptor for wheelchair access
- Stainless steel backplate and louvered grille

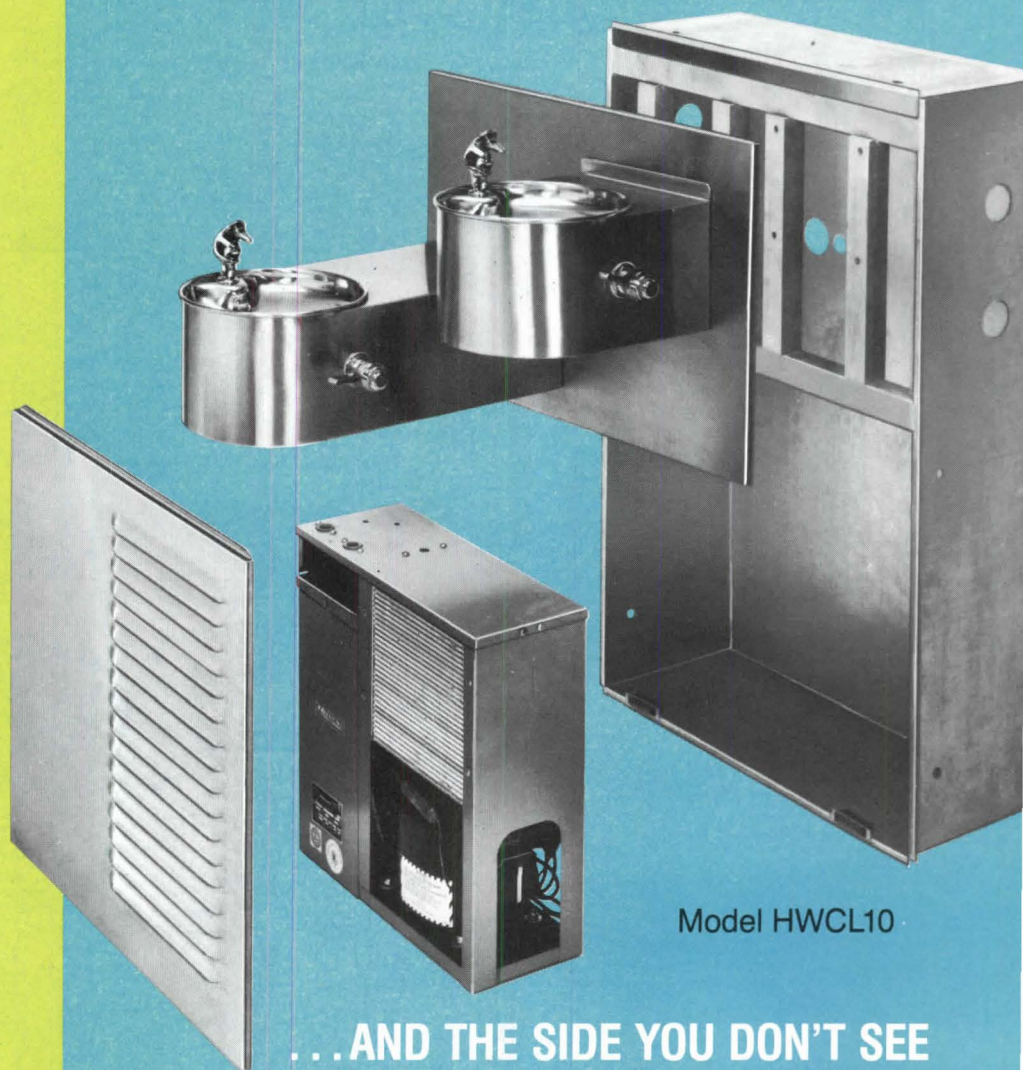

... AND THE SIDE YOU DON'T SEE

- Angle steel support struts
- Steel mounting box
- Automatic stream control
- Vandal-resistant bottom plates
- 9.5 gallon per hour chiller with 1/4 hp compressor

At Haws we make the side you see stylish, strong and practical. We put that same quality workmanship in where you don't see it, too, because we know the hidden features pay off in performance. Look at the HWCL10. You don't see the steel mounting box with angle steel struts that provide added support and strength. You don't see the automatic stream control that keeps the flow arched and even... or the vandal-resistant bottom plate* that keeps vital parts safe from mischief makers. And you don't see the efficient chiller unit that can satisfy 114 thirsty users per hour with a cold drink of water. Haws takes care to include these and other special features — because even when you don't see them, you do benefit!

HAWS DRINKING FAUCET COMPANY
P.O. Box 1999 Berkeley, California 94701
Circle 11 on information card

*Optional at extra cost.



Haws

When was the last time your elevator said "Good Morning"?



No high-rise elevator can match the new Elevonic 401 for technological innovation and comfort. As with its predecessor, Elevonic 101, all normal elevator functions are controlled by microcomputers. This improves car leveling, reduces waiting time and cuts energy consumption by 30%.

But what's really exciting about Elevonic 401 are the features we've added that make traveling by elevator a lot easier — for everybody. Like the distinctive car operating panel that's easy for tall people *and* short people to use. Or the voice that announces floors and car direction.

There's an electronic screen that can display everything from the latest news and weather to stock reports. It even has a coded push button security system that limits access to certain floors. Naturally, it exceeds code requirements for the handicapped.

Contact your nearby Otis representative today and find out why everybody is talking about our Elevonic 401 system.



Circle 12 on information card

ONLY GUARD® CAN OFFER YOU A WALLCOVERING CHOICE THIS COLORFUL.

You can put 160 of the newest Guard® vinyl wallcovering solid colors ● in the three most important textures just a glance away with the new Guard Color Selector poster. And it's yours just for the price of a stamp. From this spectrum, one of the broadest in the industry, comes a vast array of interior design possibilities. ● Bold and vibrant, thoughtful and muted, the Guard line allows you to create any mood or accent any design. These Guard patterns are available from stock in Type II material and on a custom basis in Types I and III to meet your specification requirements. ● Send for your free Guard Color Selector poster today. And begin working with the finest color ideas in today's design circles. Fill out coupon and mail to: Columbus Coated Fabrics, P. O. Box 307, Columbus, OH 43216.

Circle 13 on information card



cs-7
Send my free
GUARD Color Selector
poster as soon as you can.

NAME _____
FIRM _____
ADDRESS _____
CITY _____ STATE _____ ZIP CODE _____
COLUMBUS COATED FABRICS, P.O. BOX 307, COLUMBUS, OH 43216



AIA JOURNAL

Herewith our yearly exercise in institutional introspection, the only issue of the year devoted almost entirely to AIA. As in the past four years, the core of the issue is the "yellow pages" guide to the resources that AIA has to offer the architectural profession, intended for retention and year-round use.

Also as in the past, the issue additionally offers a listing of informational resources available from the manufacturers and suppliers of building products. This year for the first time we have assembled a similar listing of materials available from organizations closely related to the architectural profession (page 110). We are grateful for their cooperation and delighted with how many potentially useful items they have to offer.

In addition to delving into the present structure, services and resources of AIA, on the following pages we also delve into the past, presenting a sampling of the treasures in AIA's archives, which are now being professionally assembled and sorted for the first time. Such a sampling seemed particularly appropriate as the organization begins preparations for its 125th birthday, coming next year. *D.C.*



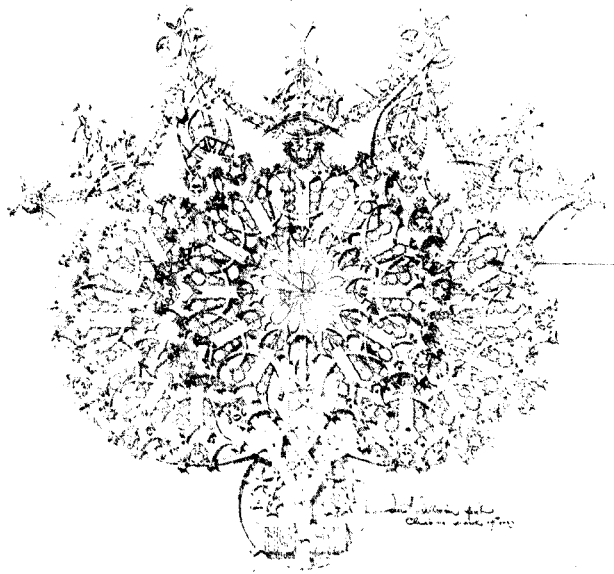

The AIA Archives

For years the “official” records of AIA—some reaching back to before the Institute was founded in 1857—were packed away in boxes on shelves in the basement of the Institute’s headquarters, gathering dust, and, in some cases, moldering. Now, after a year and a half of work by a part- and then full-time archivist and part-time assistants, materials of historical significance to the architectural profession and the evolution of AIA have been located. And, there are still more surprises to come as the discovery work continues.

Archivist Tony Wrenn estimates that there could be 1,000 to several thousand linear feet of records, which document, in Wrenn’s words, “AIA’s place in professionalizing the practice of architecture in this country, in promoting concepts of good design and planning through education, publication and organization, and in securing more adequate representation of architecture and related arts in all facets of developing the built environment.” Wrenn believes that “there is no other American architectural collection with the scope and content of this one.”

In the past, AIA members or staff have shown an interest in gathering and preserving AIA records, among them Glenn Brown, AIA secretary from 1898 to 1912, and George Pettengill, Hon. AIA, the Institute’s librarian from 1951 to 1973, and subsequent librarians Susan Holton and Stephanie Byrnes. Wrenn, however, is the first trained archivist at AIA.

Wrenn’s task is twofold. First he has to sort, clean, restore and classify the more than 125 years of material. Large prints and drawings, such as the Chinese ornamental ceiling drawings appearing on the cover and pages 42-43, are turned over to the AIA Foundation’s prints and drawings collection for storage and proper preservation. Wrenn also is working toward establishing an ongoing archival/records management program, sorting through the vast amount of material that AIA produces each year.

Wrenn has discovered an amazing variety of materials, which he has categorized as: (1) artifacts—AIA badges, pins and medals, ribbons, menus and other convention memorabilia, printing dies, silver plaques, pieces of various buildings, membership

and chapter plaques, paintings and other works of art; (2) information on AIA chapters that is sketchy during some years, exhaustive during others; (3) thousands of clippings such as obituaries, newspaper accounts of individual work, competitions, awards; (4) drawings and other graphics; (5) early letters and documents from such architects as T.U. Walter, Richard Upjohn and A.J. Davis; manuscripts from or correspondence with Lewis Mumford, Frank Lloyd Wright, Albert Schweitzer and a large number of U.S. presidents and political leaders; collections of papers of AIA presidents; (6) records of AIA’s committee activities and other Institute activities; (7) the William Stanley Parker Archive, a collection of documents and related research tracing the development of contractual policies, relationships and procedures within the design and construction industry; (8) 30,000 to 50,000 photographs; (9) material of the Western Association of Architects, which was established in 1884 and joined AIA in 1889, and (10) the AIA membership archives.

Currently, the archives are being used as an information source for dissertations and books, among them a biography of Louis Sullivan, a biographical dictionary of North Carolina builders and architects and the influence of the MIT school of architecture on 19th century architectural practice. Wrenn, however, does caution prospective users that since the catching up phase has just begun, access to archival material is now limited and arrangements should be made ahead of time.

What appears on the following pages are samples taken from the archives. At left is a charcoal drawing by Edwin H. Blashfield that was printed on the banquet program cover for the first gold medal presentation in 1907, which was given to Sir Aston Webb at the Willard Hotel in Washington, D.C. The original casts for the gold medal by A. A. Weinman are also in the archival collection. Above is a sketch by Louis Sullivan from his book *A System of Architectural Ornament*. The sketch appears on the last page of the book, which was published by the Press of the American Institute of Architects, Inc., in 1924.

continued on page 23



Double dribble.

Keeping the water off the roof. And off the floor.

That's the name of the game.

And the reason why it pays to specify Johns-Manville—the first name in lasting built-up roof protection.

With J-M, you get expertise based on over 120 years of solving roofing problems. You get quality that's consistently tops throughout a complete

line of roofing products, components and systems. Plus technical assistance from America's most experienced team of roofing specialists. And a degree of roof guarantee coverage that tops any in the industry.

Score with the built-up roof that offers real protection. For details, consult Sweet's. Or contact George Constantin, Johns-Manville, Ken-Caryl Ranch, Denver, Colorado 80217, 303/978-3281.

**Keeping the water out.
That's what this business is all about.**



Johns-Manville

Circle 14 on information card

Columbia supertube!

Fluorescent lighting that goes up,...
over... down... or around corners...
wherever you want it!



Columbia
Lighting
Inc

T.A. Box 2787 • Spokane, WA 99220

GTE

USI A Subsidiary of
U.S. INDUSTRIES, INC.

Columbia Lighting's versatile aluminum supertube brings flexibility and sparkling colors to architectural lighting. They may be suspended from ceilings or bracket mounted on walls in standard or custom sizes to fit your job. Lamp openings are symmetrically centered and each fixture retains its own "turnability" . . . you can aim it. For more information contact your Columbia agent or write us; we have answers to lighting questions you've yet to ask.

Circle 15 on information card

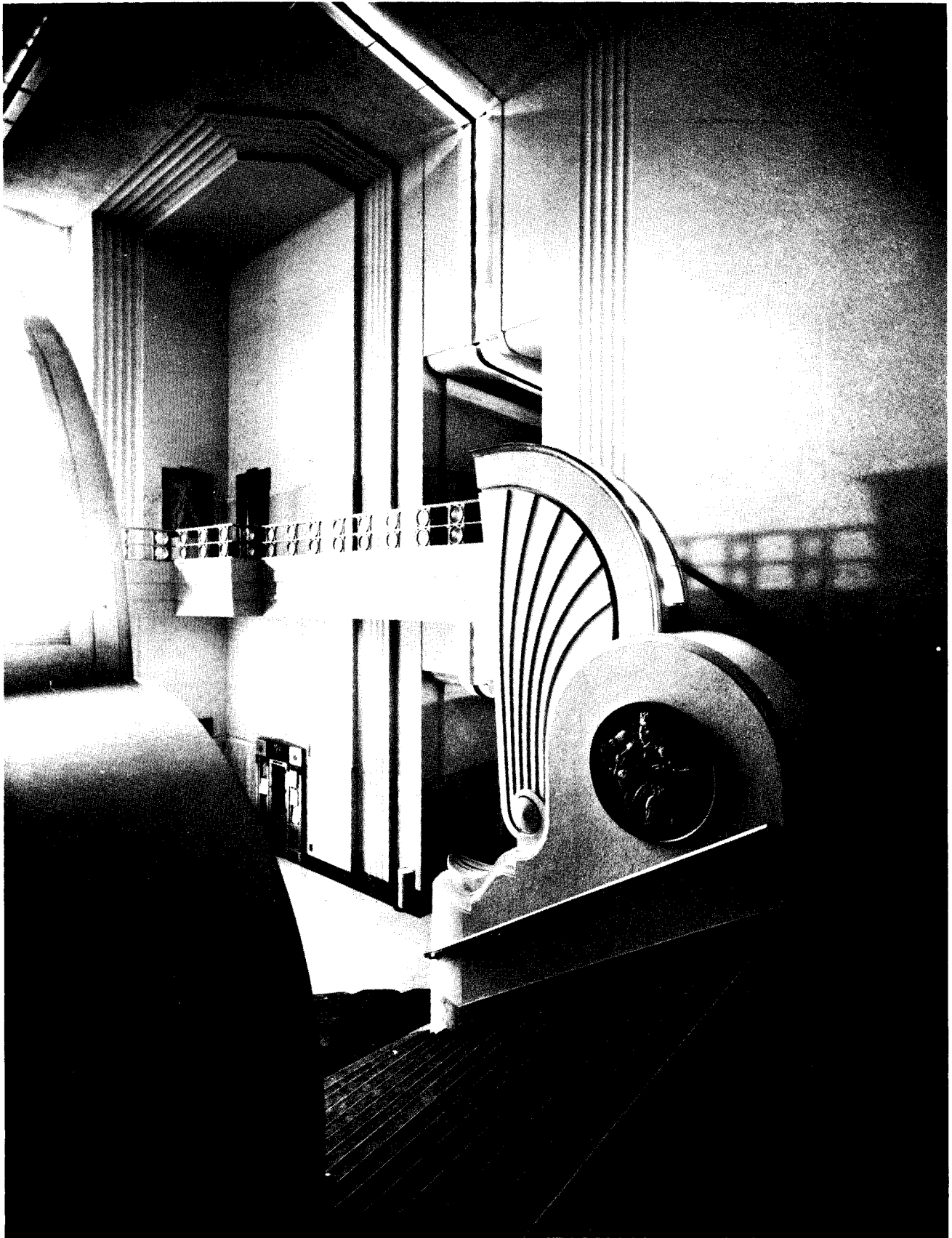

The Burbank, Calif., city hall and jail was designed in the early 1940s by William Allen and W. George Lutzi. Thirty photographs of the building were included in an "architect's roster," sent to AIA with the firm's registration for federal design work. The city hall is still standing; the jail has been moved across the street.

continued on page 24

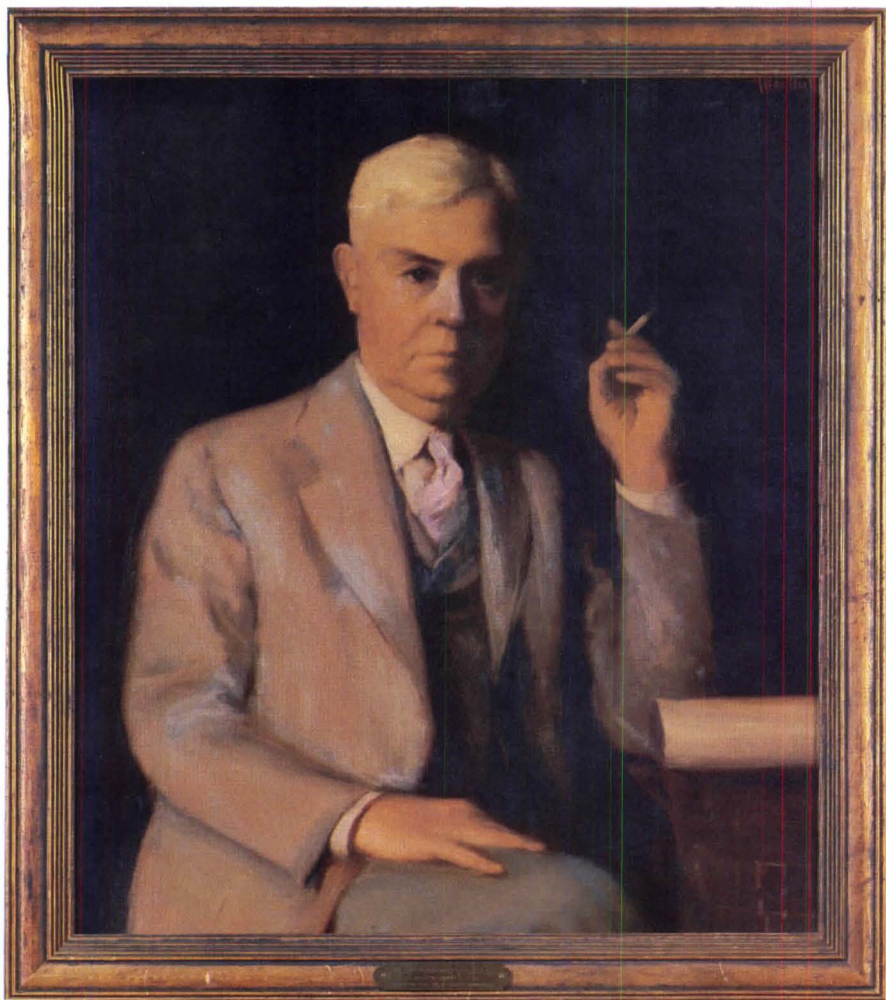

Two of the many portraits of AIA presidents: above, Ernest John Russell of St. Louis, president from 1932 to 1935, oil painting by J. Scott MacNutt; and right, George Browne Post, New York City, president from 1896 to 1898, oil painting by Edwin H. Blashfield.





The New York Chapter certificate, designed in 1870 by Edward Nevill Stent, is signed by Richard Upjohn and P.B. Wight. The chapter was founded in March 1867. Above, the presentation of the AIA gold medal to Henry Bacon at the Lincoln Memorial in 1923. At that time medalists were nominated by the conventioners, with presentation of the award at a later date. In 1923, a banquet was held at the end of the reflecting pool nearest the Washington Monument. After dinner, the guests—dressed in felt robes of various colors—lit torches and watched as a barge carrying Bacon was poled down the pool. At the Lincoln Memorial, Bacon was met by President Warren G. Harding and Chief Justice William Howard Taft. Of the event, AIA JOURNAL Editor Charles H. Whitaker wrote: “It was a Venetian carnival—it was a Roman Emperor holding court and receiving his vassal subjects, it was a medieval pageant before the king after the tourney, it was a ceremonial of the old Indian guildsmen. . . .”

continued on page 31

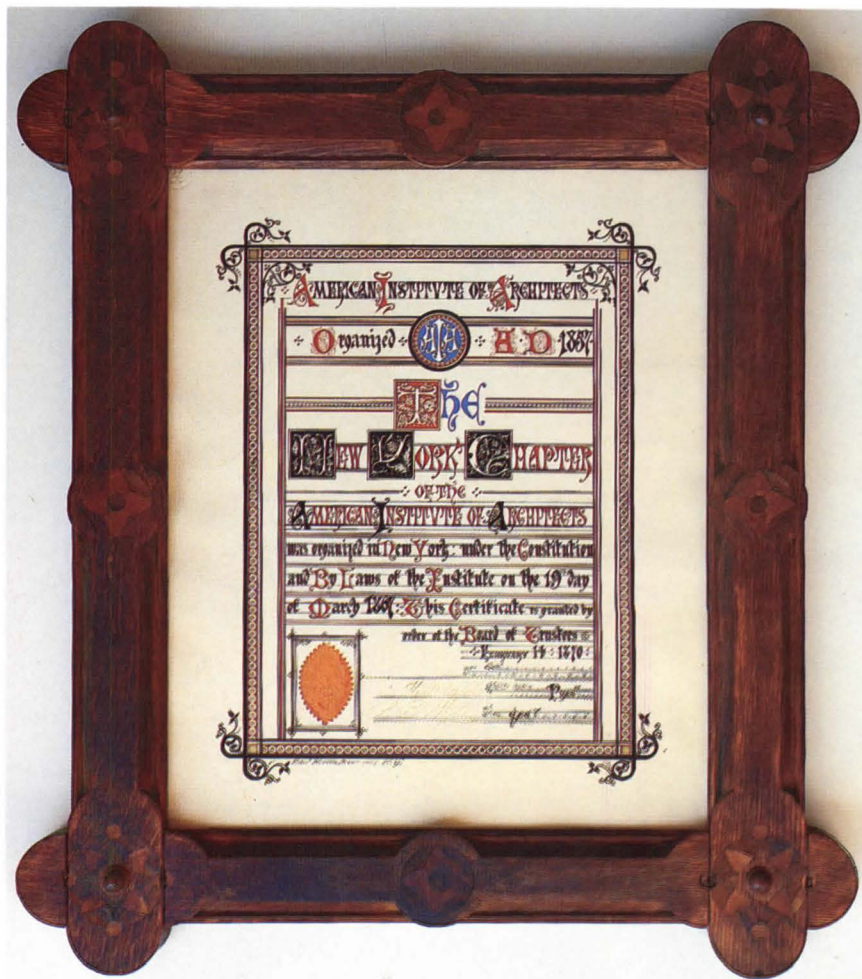

How to flush out the real thing in flush valves.

Look for all these precision features. And you'll be looking at the real thing—a Sloan Flush Valve. For example, look at the inside cover. Sloan's is molded of the finest thermoplastic. There's no need for regulation and water delivery is consistent and dependable.

The tailpiece is adjustable to compensate for roughing-in error. Its leakproof connection can't be accidentally disengaged.

BAK-CHEK means pressure losses—even to negative pressures—have no effect. When pressure's restored, the valve's ready to go.

Our relief valve has a sliding gland for non-hold-open operation. The valve flushes, then shuts off automatically, even if the handle is held down. That saves water. And it's been a Sloan standard for years.

We use high-grade natural rubber for the segment diaphragm. In 75 years, we've found nothing beats rubber for long service. And we mold brass segments into the diaphragm for positive closing at the main seat.

The guide is ABS engineered plastic. In combination with either of two relief valves, it'll satisfy any fixture requirement.

The lip seal on the handle needs no adjustment. And a nylon sleeve eliminates metal-to-metal contact between handle and socket.

The real thing. A Sloan Flush Valve. For real water savings and real-life dependability.



SLOAN VALVE COMPANY
10500 Seymour Avenue, Franklin Park, IL 60131

Circle 16 on information card

A close-up photograph showing a person's thumb and index finger holding a thin, light-colored rectangular object (likely a piece of paper or a thin card) between two dark, textured surfaces. The object is held at an angle, creating a very narrow gap between the surfaces. The background is a dark, textured surface, possibly a book cover or a similar material. The lighting is soft, highlighting the texture of the surfaces and the skin of the hand.

**The 35,000ths
of an inch space
that's starting a
revolution.**

T&B's revolutionary Versa-Trak™ Under Now, put power where you want it w

There's a new way to wire commercial office buildings. Gone are overhead raceways, under-floor ducts, power poles and poke-thru devices. Gone also are the design restrictions that go with them. Today, there's the VERSA-TRAK™ System from Thomas & Betts, a system for distributing power (110 to 240V), telephone and data in exactly the same way as conventional cable with one big exception—the VERSA-TRAK™ System is **flat** not round.



Less than thirty-five thousandths of an inch thick, the VERSA-TRAK™ Wiring System is installed on top of structural floors and covered by standard carpet squares.

Think of the possibilities! Offices, whether open or closed, new or retrofit, can be designed to meet your present needs—without imposing restrictions for the future. All pedestals can be located under desks, **out of sight**. And, changing the position of a desk becomes a simpler task since pedestals

can be moved easily and quickly **without** any disruption to office routine.

But there's more to the VERSA-TRAK™ Wiring System revolution than design freedom. For one thing, the VERSA-TRAK™ System is designed to save you money. Because installation is fast and simple, you can **save up to 40%** on your installed costs. And you'll save on structural costs too. The VERSA-TRAK™ System is installed right on the floor, so there's no need to increase the floor pour height to meet the needs of a conventional in-slab system. This turns into considerable structural savings. Also, considerable **tax advantages** may exist as well.

With the VERSA-TRAK™ System **Installation scheduling** is as



Carpet Wiring System. An unprecedented design freedom.

flexible as the cable. Your electrical needs can be scheduled for a



later stage of construction or even delayed until building completion. Renovation projects? Nothing even comes close to the perform-

ance of the T&B VERSA-TRAK™ System. There's **no dismantling or piercing** of any structural component. Floor penetration for wiring is completely eliminated so the structural integrity of any existing building is preserved, while the electrical needs are updated.



The VERSA-TRAK™ System is **UL listed** and covered in Article 328 of the 1981 National Electrical Code. You'll find the VERSA-TRAK™ Wiring System doing the job now, in hundreds of commercial buildings throughout the country... isn't it time you joined the VERSA-TRAK™ System revolution?



T&B

Don't wait! Learn about the VERSA-TRAK System **Now**. Write for information about future T&B seminars. Or call your nearest T&B VERSA-TRAK System wiring specialist listed on the following page.



The Versa-Trak™ System Wiring Specialists

ATLANTA

Thomas & Betts
5825 Glenridge Dr.
Bldg. 4—Suite 108
Atlanta, Ga. 30328
(404) 252-9670

BOSTON

Thomas & Betts
10 Forbes Road—Suite 24
Braintree, Mass. 02184
(617) 843-0373

CHARLOTTE

Thomas & Betts
6000 Monroe Road
Suite 228
Charlotte, N.C. 28212
(704) 568-6868

CHICAGO

Thomas & Betts
255 E. Lake Street
Suite 202
Bloomington, Ill. 60108
(312) 894-2010

CINCINNATI

Thomas & Betts
5725 Dragon Way
Colonial Center Bldg.
Cincinnati, Ohio 45227
(513) 271-6686

DENVER

Thomas & Betts
3508 Peoria St.—Suite 411
Aurora, Colo. 80010
(303) 344-5585

DETROIT

Thomas & Betts
25882 Orchard Lake Road
Farmington Hills,
Mich. 48018
(313) 477-7760

LOS ANGELES

Thomas & Betts
17150 Norwalk Blvd.
Suite 113
Cerritos, Ca. 90701
(213) 402-3101

MINNEAPOLIS

Thomas & Betts
529 S. 7th Street
Minneapolis, Minn. 55415
(612) 333-2419

NEW YORK/NEW JERSEY

Thomas & Betts
51 Cragwood Road
So. Plainfield,
New Jersey 07080
**(201) 561-4700 or
(212) 227-8644**

PHILADELPHIA

Thomas & Betts
125 Gaither Drive—Suite E
East Gate Industrial Center
Mt. Laurel, New Jersey 08054
**(609) 235-7440
(215) 922-4236**

SAN FRANCISCO

Thomas & Betts
1762 Technology Drive
Suite 108
San Jose, Calif. 95110
(408) 298-7464

ST. LOUIS/NEW ORLEANS

Thomas & Betts
334 Brookes Drive—Suite C
Hazelwood, Mo. 63042
(314) 731-3338

HOUSTON

Thomas & Betts
9039 Katy Freeway
Suite 340
Houston, Texas 77024
(713) 461-0610

Thomas & Betts Corporation, 920 Route 202, Raritan, New Jersey 08869, (201) 685-1600

T&B

CONSTRUCTION & MAINTENANCE

Copyright 1981 Thomas & Betts Corporation. All rights reserved.

Circle 17 on information card

*Write to the Bulletin
L.A. Apr 9/1898*

*A. J. G. Coffin
Repr. 26/75
Sends views*



OCEAN FRONT
OF THE
SANTA BARBARA GRAND HOTEL,
SANTA BARBARA, CAL.
G. B. CROFF, Architect and Constructing Engineer.

This Magnificent Hotel, now projected, will, when completed, be the largest on the face of the globe, containing, exclusive of its many grand saloons, concert and dancing halls, one thousand eight hundred rooms. Ceilings of first or saloon floor being 25 feet, those above in proportion. The grand central tower rising to the height of two hundred and sixty-six feet above the level of carriage drives, visible for many miles away from the surrounding landscape and the sea. Three elegant steam elevators, and six grand stair cases, render the upper halls easy of access and safe for occupation. Its entire appointments will be magnificent in the extreme, and the decorations in fresco and ornamental plaster work palatial in conception. The spacious and beautiful open court in front, looking onto the placid bosom of the Pacific, which bears at this point a striking resemblance to the world-renowned bay of Naples, lacking only the towering figure in the background of everlasting Vesuvius to complete the picture, will be, with its elaborate fountains and floral decorations, one of the most bewitchingly beautiful pictures of art and nature to be seen on earth, vying with the Champs Elysees of Paris and the wonderful grounds of the Sydenham Palace, England.

Dear toge Springs April 26-98

*Mr A. J. Bloor
My Dear Sir*

LOUIS M. MOWBRAY JUSTIN M. UFFINGER

MOWBRAY & UFFINGER,
ARCHITECTS
49 LIBERTY ST
New York, November 4th, 1898

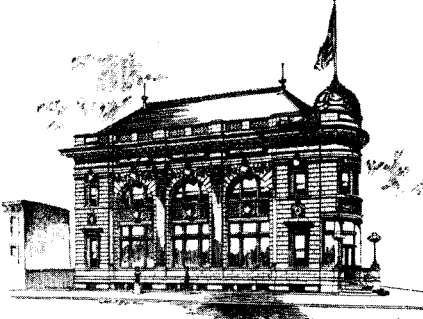

Through the courtesy extended to us by the Directors of the Peoples' Bank of Brooklyn, we take pleasure in inviting you to inspect their new banking building and banking vaults which have recently been erected from our designs and under our supervision. This building, as above illustrated, is a recent example of our work in Banking Architecture, of which we make a specialty. We shall be pleased to hear from you should you contemplate improving your present quarters or banking vaults.

Yours very respectfully,
Mowbray & Uffinger



Architectural composition, to be good, should be free from every impertinence, and were it within my scope to describe the architecture of the present time, I should be compelled to search the Divina Commedia of Dante, or the Romance of Rabelais for terms adequately forcible for the expression of its licentiousness and depravity.

Alex J. Davis.



Robert L. Roeschlaub

Denver, Colo.

A HAPPY NEW YEAR.

In the late 19th and early 20th centuries, the letterheads of architects were adorned with drawings of their work and, in some cases, with descriptions of the buildings (as in the letter, upper left). This practice was discontinued in the early 1900s, possibly as a result of AIA's changing view of advertising. The "Happy New Year" postcard, above, is from Denver architect Robert L. Roeschlaub, FAIA, who was active in Colorado Chapter/AIA affairs. He lived from 1843-1923.

continued on page 37

R. P. DAGGETT, ARCHITECT

R. P. DAGGETT & CO.
ARCHITECTS

ESTABLISHED IN 1868.
TELEPHONE 619.
INDIANAPOLIS, IND.



JAMES B. LIZIUS, ARCHITECT

*Respy 28-32
MARION BLOCK
NEW CORNER
MERIDIAN AND
OHIO STREETS*

Indianapolis, Ind. Aug. 31 1895



The height of ceiling fashion.

**Featuring the Grinnell Designer Series of Ceiling Sprinklers.
Because necessity needn't cramp your style.**

The Designer Series of Ceiling Sprinklers allows you the greatest possible design latitude without letting their presence detract from features that make your building unique.

Our new Cleanline II, for instance, is 25% smaller in diameter than previous Cleanline models. And other Designer Series models,

such as our new, smaller-sized Recessed and Flush Ceiling Sprinklers, can be installed before the ceiling itself is in place.

They're unobtrusive, yet recognizable as sprinklers to give building occupants greater peace of mind. They're easy to install, which helps save on labor costs. And they're competitively priced.

Write for information on the Cleanline II and other models in Grinnell's Designer Series of Ceiling Sprinklers—Recessed, Flush or Quartzoid types. Contact: Grinnell Fire Protection Systems Company, Inc. 10 Dorrance Street Providence, Rhode Island 02903 Attn: Advertising Department



GRINNELL
GRINNELL FIRE PROTECTION SYSTEMS COMPANY, INC.

Circle 18 on information card

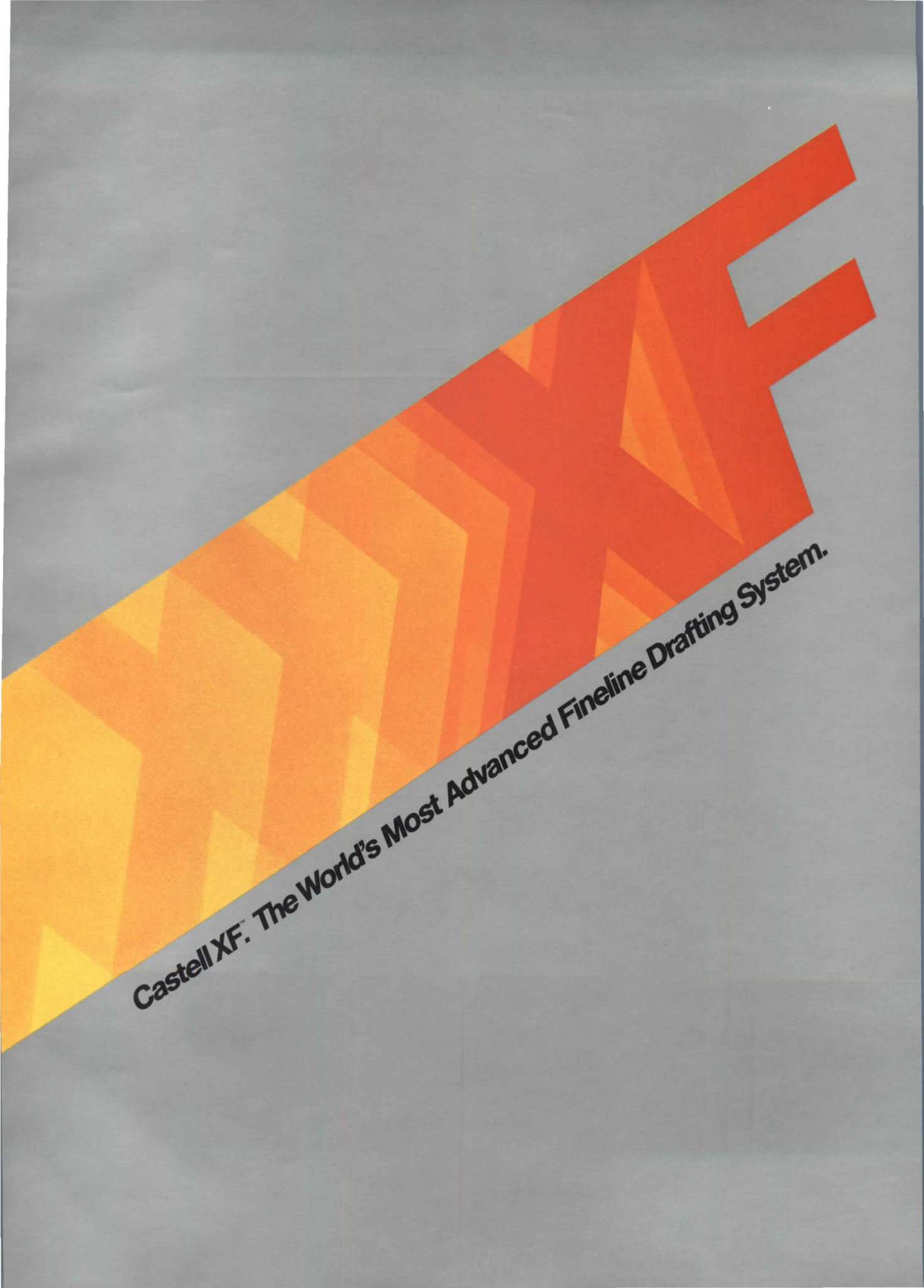

Castell XF. The World's Most Advanced Finesline Drafting System.

The Castell XF™ Fine

Now, it's incredibly easy to make precise, accurate pencil drawings with constant fine lines. Just put the Castell XF Finesline Drafting System to work.

Standardize your drawing specifications within the four line widths of the system—0.3mm, 0.5mm, 0.7mm and 0.9mm. Castell XF Pencils and Leads are designed to make line specification easier because they're color-coded to the line width designations established by the International Standards Organization.

Castell XF Leads are extruded to the exact diameters you need to draw black, dust-free lines that reproduce perfectly. For working on paper or vellum, use Castell XF Tempered Polymer Leads and on drafting film, try Castell XF Filmar Leads.



Castell XF 9710 Series Pencils
Special color-coded bars on barrel conforming to the line width designations established by the International Standards Organization. The semi-retracting sleeve prevents lead breakage and permits up to 3 times longer drawing before the lead needs to be advanced. Exclusive Tel-A-Grade degree indicator adjusts to show lead degree in use. Eraser, cleaning wire and spare lead under pushbutton cap. Available in all four diameters.



Castell XF 9780 Series Pencils
Special color-coded barrels conforming to the line width designations established by the International Standards Organization (ISO). Semi-retracting sleeve prevents lead breakage and permits up to 3 times longer drawing before lead needs to be advanced. Eraser, cleaning wire and spare lead under pushbutton cap. Available in all four diameters plus working set.

Castell XF Film 9750 Series Pencil
Semi-retracting sleeve prevents lead breakage and permits up to 3 times longer drawing before lead needs to be advanced. Ivory color-coded impregnated lead reproduces ISO line width. Eraser, cleaning wire and spare lead under pushbutton cap. Available in 0.5mm and 0.9mm diameters.

Precision that s

Fineline Drafting System

Then, bring out the best in the leads with Castell XF or Castell XF Filmar Pencils. The semi-retracting sleeves prevent lead breakage.

Increased efficiency is the result. You can maintain line consistency from drafter to drafter.

Plus, you save money. Compared to the cost of 2mm drawing leads, you can save up to 75%. You eliminate lost man-hours and lead wastage because Castell XF Leads never need sharpening. You even benefit from significant savings on stockroom inventories of pencils, leads, lead holders and pointers.

Castell XF. It's the world's most advanced fineline drafting system.



Castell XF 9760 Series Pencils

Economy-priced fineline pencils with the fixed sleeve preferred by some drafters for working with templates. Eraser, cleaning wire and spare lead under pushbutton cap. Available in all 4 diameters plus working set.

Castell XF 9060 Series Tempered Polymer Lead

A superior blend of polymer and graphite with extra blackness produced by polymeric carbon. Precise extrusion in all diameters for constant line width. Produces superior opacity with less dust for cleaner drawings. Eliminates costly touch-up. Available in all four diameters in a variety of grades.

Castell XF Filmar 9050 Leads

Special longer-wearing formula for use on toothy polyester drawing film surface. Excellent opacity for superior reproduction. Available in 3 degrees in 0.5mm, 0.7mm and 0.9mm diameters.

Castell XF 9080 Series Color Lead

Strong plastic color leads available in red or blue in 0.5mm and 0.9mm diameters.

saves you money.

Switch to the Castell XF™ Fineline Drafting System.

Castell XF Pencil	0.3mm	0.5mm	0.7mm	0.9mm	Set
9710 Series 	9713	9715	9717	9719	
9750 Series 		9755	9757	9759	9750S
9760 Series 	9763	9765	9767	9769	9760S
9780 Series 	9783	9785	9787	9789	9780S

Castell XF Tempered Polymer Lead	2B	B	HB	F	H	2H	3H	4H	5H
0.3mm / 9063P			X		X	X		X	
0.5mm / 9065P		X	X	X	X	X	X	X	X
0.7mm / 9067P		X	X		X	X	X	X	
0.9mm / 9069P	X	X	X		X	X	X	X	

Castell XF Filmar Lead	F-1 Soft	F-2 Medium	F-3 Hard
0.5mm / 9055	X	X	X
0.7mm / 9057	X	X	X
0.9mm / 9059	X	X	X

Castell XF Color Lead	Red	Blue
0.5mm / 9085	X	X
0.9mm / 9089	X	X

Circle 100

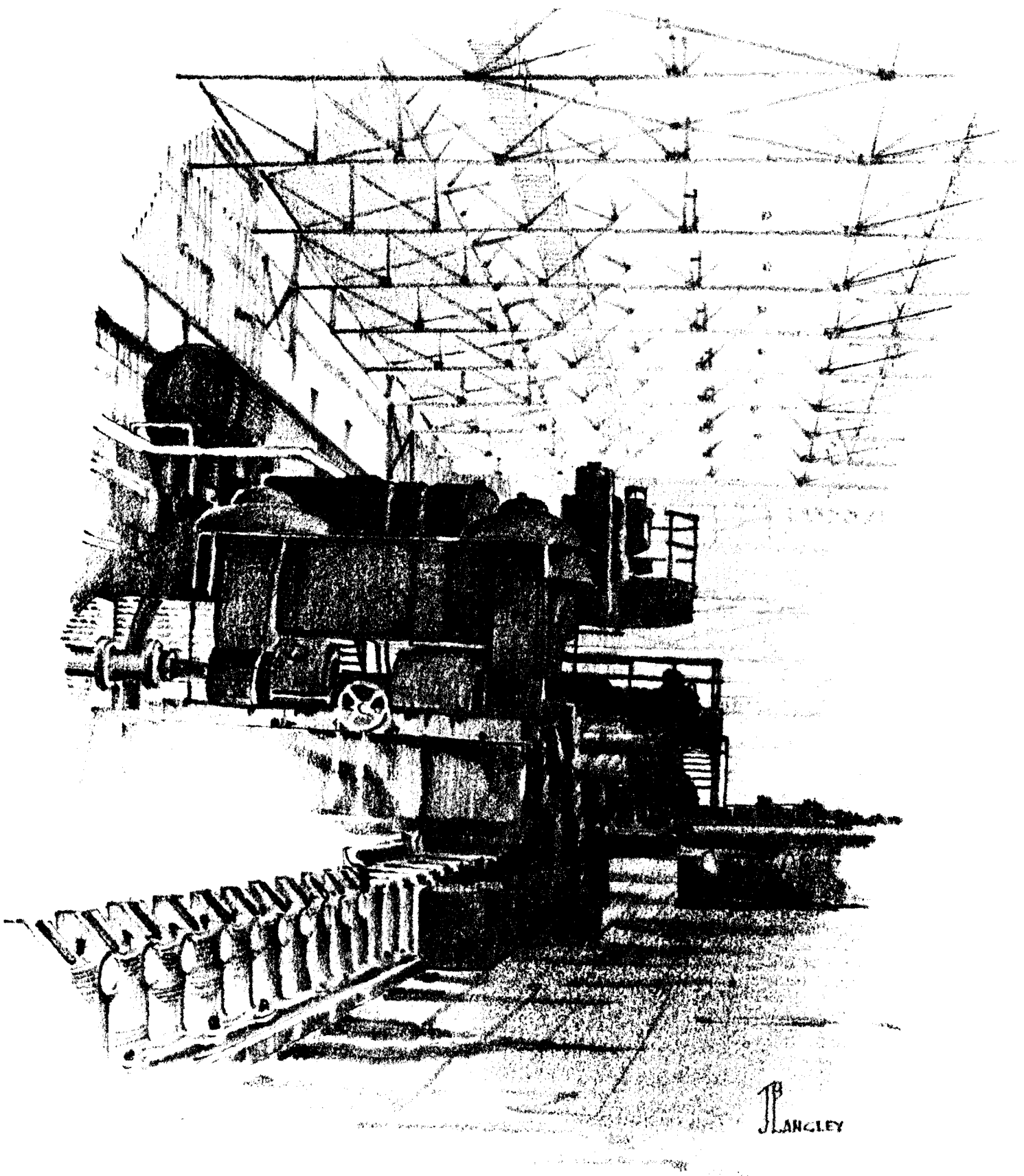

Pencil sketch by Canadian architect John Bernard Langley is from a 1940 report entitled "Industrial and Commercial Architecture." From 1933-44, recipients of an Edward Langley scholarship (the two Langleys are not related) were required to produce a final report. Other topics are Pennsylvania barns, town planning in the Southwest and bomb shelters.

continued on page 38

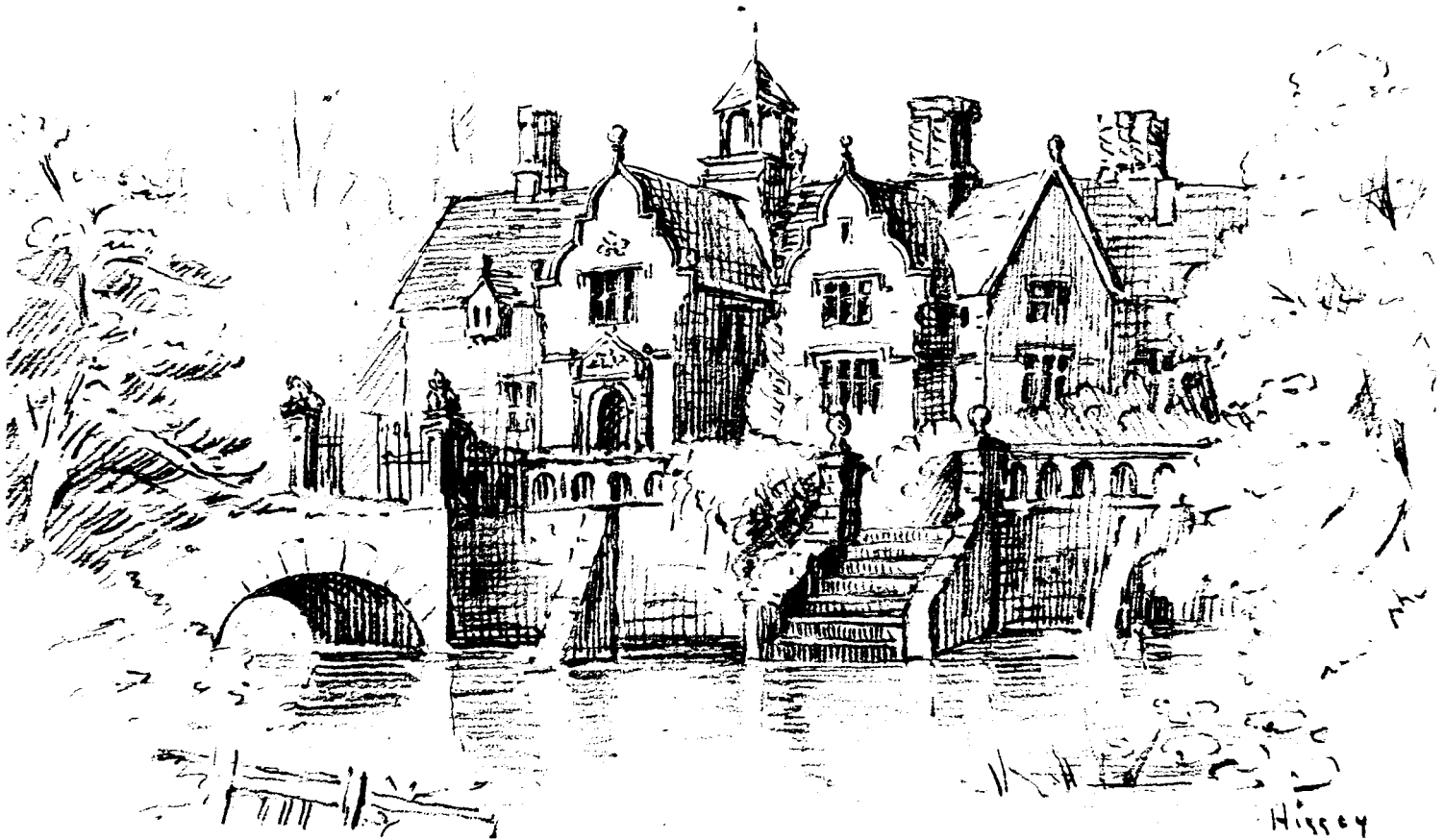

The manor house shown above is from a 1887-1889 sketchbook of Edwin Clarke Cabot. Below, the only surviving copy—of 300 printed—of AIA's 1857 constitution. It was used by Richard Morris Hunt, the first secretary. Among the doodles in Hunt's copy is the drawing below that reads: "No. 1 Renaissance female [to the left] No. 2 modern ditto. Your most humble cum tumble secretary." The original sheepskin constitution has also been located. At left is a drawing by Alfred Bendiner, FAIA, from a 1953 letter concerning the West Front of the Capitol. Bendiner complained that on one hand an AIA committee was asking members to write to congressmen supporting preservation of the West Front. On the other AIA had supported the hiring of architects by the federal government, architects who concluded that an extension should be built. An exhibit of Bendiner's drawings will be on display at the Octagon in the fall. *continued on page 42*

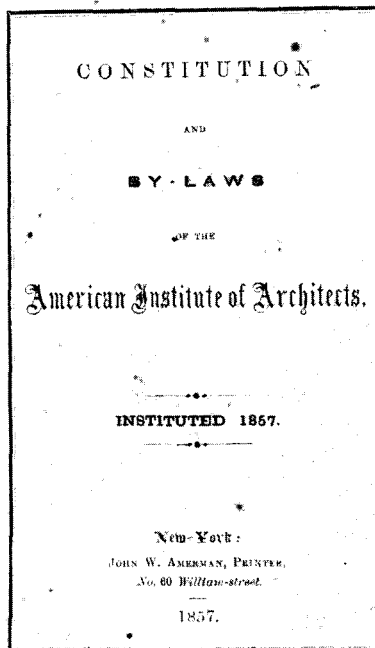

How New York's new hotels are insulating against roof overhead.

When you're putting first-class buildings on some of the most expensive land in the world, you don't compromise on the roof systems. That's why all four of New York's newest hotels have IRMA protected membrane roofs with STYROFOAM® brand insulation.

Developed by Dow, the IRMA (Insulated Roof Membrane Assembly) system is a simple, economical way to build a leak-free, moisture-resistant, abuse-tolerant, insulating roof. Once considered revolutionary, the IRMA system is fast becoming America's standard for trouble-free, high performance roofs.

Installation is fast, easy and comparable in cost to a conventional insulated roof. Long-term savings on energy and maintenance costs are substantial.

And the use of extra insulation may even allow downsizing of heating and cooling equipment.

Before you design or build, evaluate your roofing alternatives. Let your Dow representative explain all the benefits of the IRMA system and provide data to support STYROFOAM brand insulation's superior insulating effectiveness and long-term performance. Then you'll see why roof systems incorporating STYROFOAM are so widely specified by architects and contractors throughout America, and the world.

For further information call your local Dow representative or write: The Dow Chemical Co., Dept. H57, STYROFOAM Brand Insulation, Midland, MI 48640.

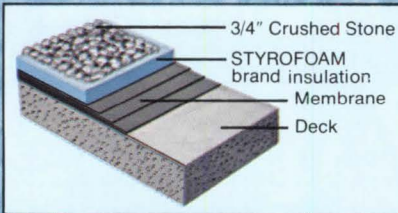

*Trademark of The Dow Chemical Company

Styrofoam®

BRAND

Vista International, New York;
lower Manhattan's first new hotel in 150 years;
Skidmore, Owings, Merrill, Architects.

WARNING: STYROFOAM brand insulation is combustible and should be properly installed. For roofing applications it should be provided with an adequate protection. For specific instructions see Dow literature available from your supplier or from Dow.

1-182 © 1981 The Dow Chemical Company

Circle 20 on information card

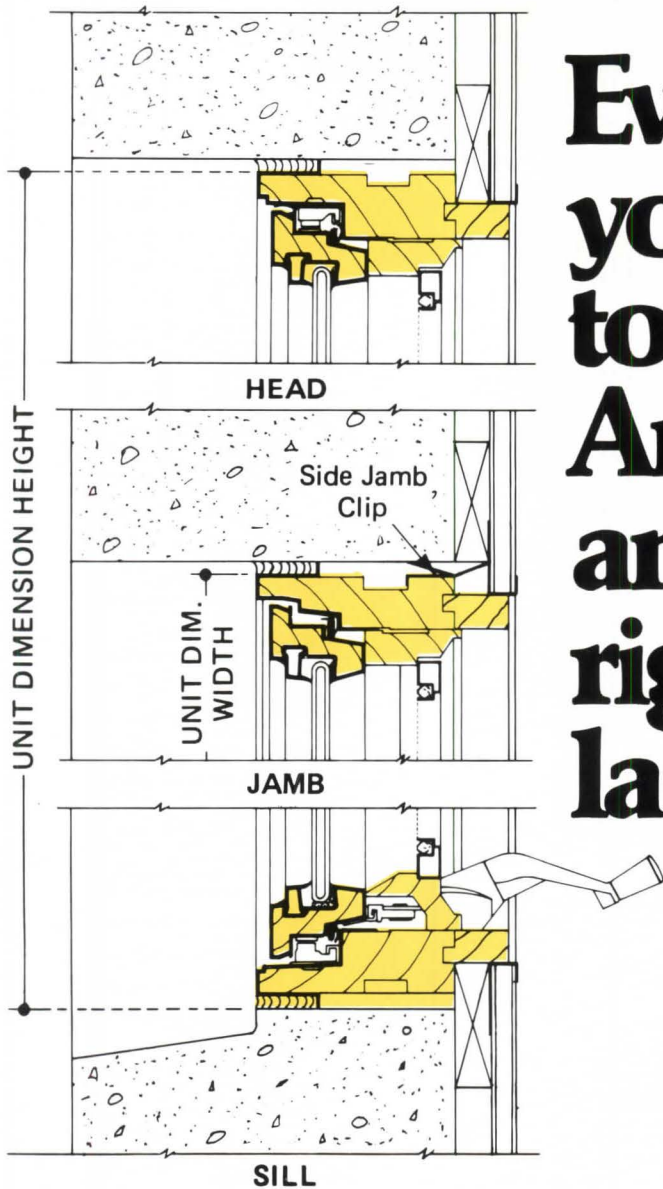

Everything you've wanted to know about Andersen[®] windows and gliding doors right down to the last beautiful detail.

There's more to specifying quality windows and gliding doors than just their brand name. Even if that name is Andersen[®].

To make your job easier, we present the entire Andersen line with complete technical data in every detail. And to scale. In elevations and installations in all types of wall construction.

So now you'll know how the window fits in, before it gets to the job.

There's also a reproducible aid to take a lot of the time and work out of making your detail drawings and a complete guide to the Andersen Window Replacement System.

A product detail book, too.

Plus, of course, our Sweet's file on Andersen windows and gliding doors.

And Manu-Specs on all products in conformance with CSI 3-Part Section format.

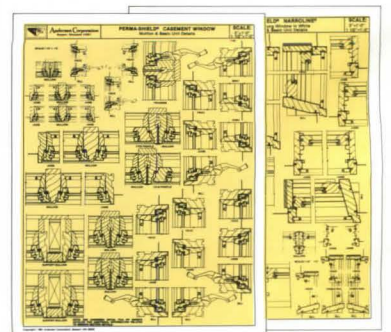
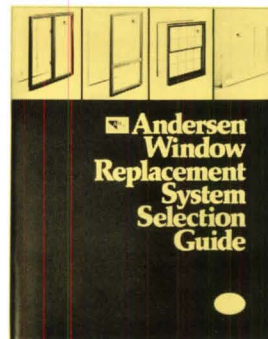
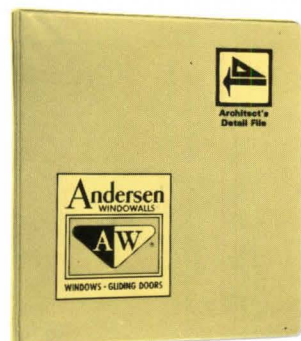
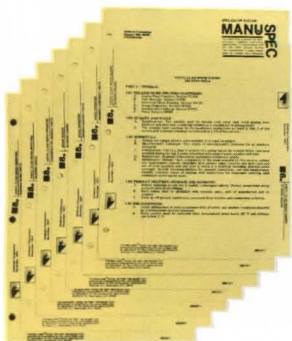

Call Us For All The Facts.

ALABAMA

BIRMINGHAM — Birmingham Sash & Door Co. — (205 254-3276)

ARIZONA

TEMPE — Edward Hines Lumber Company — (602 894-0930)

ARKANSAS

NO. LITTLE ROCK — Fischer Lime & Cement Co. — (501 376-2911)

CALIFORNIA

FAIRFIELD — Sequoia Supply — (707 864-1711)

OAKLAND — Western Door and Sash Co. — (415 535-2000)

ORANGE — Sequoia Supply — (714 974-2330)

COLORADO

DENVER — Boise-Cascade Corp. — (303 629-1629)

DENVER — Morgan Sash & Door Co. — (303 373-0210)

CONNECTICUT

NORTH HAVEN — Brockway-Smith Company — (203 239-1603)

ROCKY HILL — Cleary Millwork Co. — (203 721-0520)

DELAWARE

BEAR — C-E Morgan Distribution — (302 322-1227)

FLORIDA

FORT MYERS — Huttig Sash & Door Company — (813 332-2424)

JACKSONVILLE — Huttig Sash & Door Company — (904 786-1622)

LARGO (St. Petersburg) — C-E Morgan Building Products — (813 393-4681)

ORLANDO — Huttig Sash & Door Company — (305 295-9020)

RIVIERA BEACH — Weiler-Wilhelm Window & Door Company — (305 845-1555)

GEORGIA

NORCROSS (Atlanta) — Winter of Atlanta — (404 448-0440)

IDAHO

BOISE — Chandler Corporation — (208 375-5050)

ILLINOIS

DECATUR — C-E Morgan Sash & Door Co. — (217 877-4621)

PEORIA — Wahlfeld Mfg. Co. — (309 673-4421)

ROCK ISLAND — Rock Island Millwork Company — (309 788-0421)

SKOKIE — EHLCO — (312 761-6600)

WEST CHICAGO — Wahlfeld's — (312 293-1000)

INDIANA

GOSHEN — Goshen Sash & Door Co. — (219 533-1146)

INDIANAPOLIS — Midland Sash & Door Inc. — (317 837-3381)

TERRE HAUTE — Associated Door & Plywood Co. — (812 232-1371)

IOWA

CEDAR RAPIDS — Rock Island Millwork Company — (319 365-6904)

DES MOINES — Rock Island Millwork Company — (515 265-6071)

DUBUQUE — Rock Island Millwork Company — (319 588-0551)

MASON CITY — Mason City Millwork Co., Inc. — (515 423-2822)

SIoux CITY — Jordan Millwork Company — (712 258-7554)

WATERLOO — Rock Island Millwork Co. — (319 233-3331)

KANSAS

LENEXA (Kansas City) — C-E Morgan Distribution — (913 888-5900)

WICHITA — Rock Island Millwork Co. — (316 264-8375)

WICHITA — Rounds & Porter Co. — (316 262-1465)

KENTUCKY

LEXINGTON — Combs Company — (606 254-3321)

LOUISVILLE — Allied Sash & Door, Inc. — (502 361-8481)

LOUISVILLE — Huttig Sash & Door Co. — (502 491-4560)

LOUISIANA

ALEXANDRIA — Davidson Louisiana, Inc. — (318 442-1355)

BATON ROUGE — Davidson Louisiana, Inc. — (504 387-6746)

HOUMA — Davidson Louisiana, Inc. — (504 879-2313)

KENNER — Davidson Louisiana, Inc. — (504 466-4558)

LAFAYETTE — Davidson Louisiana, Inc. — (318 234-6373)

LAKE CHARLES — Davidson Louisiana, Inc. — (318 439-8393)

MONROE — Davidson Louisiana, Inc. — (318 323-2273)

MAINE

PORTLAND — Brockway-Smith Company — (207 774-6201)

MARYLAND

BALTIMORE — Robbins Door & Sash Co. — (301 796-7766)

BARCLAY (Eastern Shore) — Delmarva Sash & Door Co. — (301 438-3102)

MASSACHUSETTS

ANDOVER (Boston) — Brockway-Smith Company — (617 475-7100)

EAST LONGMEADOW — Brockway-Smith Company — (413 525-3377)

SPRINGFIELD — Martin Lumber Company — (413 788-9634)

MICHIGAN

BIRCH RUN — Morgan Sash and Door Co. — (517 624-9383)

GRAND RAPIDS — Grand Rapids Sash & Door Co. — (616 784-1500)

HOLT (Lansing) — Grand Rapids Sash & Door Co. — (517 694-2108)

SCHOOLCRAFT (Kalamazoo) — Grand Rapids Sash & Door Co. — (616 679-5205)

TRAVERSE CITY — Grand Rapids Sash & Door Co. — (616 947-5420)

WIXOM (Detroit) — Kimball & Russell, Inc. — (313 624-7000)

MINNESOTA

DULUTH — The Radford Company — (218 624-3654)

MINNEAPOLIS — Independent Millwork Inc. — (612 425-8600)

ST. PAUL — Pacific Mutual Door Company — (612 631-2211)

MISSOURI

CAPE GIRARDEAU — Associated Building Centers, Inc. — (314 335-8231)

HAZELWOOD (St. Louis) — Chromalloy Building Products Div. — (314 731-1401)

KANSAS CITY — Pacific Mutual Door Company — (816 531-0161)

MARYLAND HEIGHTS (St. Louis) — St. Louis Millwork Company — (314 872-8724)

ST. JOSEPH — Associated Building Centers, Inc. — (816 232-7744)

SPRINGFIELD — Toombs & Company — (417 862-9377)

MONTANA

BILLINGS — Boise-Cascade Corp. — (406 652-3250)

GREAT FALLS — Lumber Yard Supply Co. — (406 453-0356)

MILES CITY — Richland Lumber Co. — (406 232-1345)

MISSOULA — Exchange Lumber Co. — (406 549-5121)

NEBRASKA

OMAHA — Disbrow & Co. — (402 341-0774)

OMAHA — Jordan Millwork Co. — (402 334-7660)

SCOTTSBLUFF — Huttig Sash & Door Co. — (308 436-2151)

NEW JERSEY

MIDLAND PARK — Black Millwork Co., Inc. — (201 445-5700)

RIDGEFIELD — Whittier-Ruhle Millwork Co. — (201 943-6600)

WOODBURY HEIGHTS — Middle Atlantic Millwork Co. — (609 848-8000)

NEW MEXICO

SANTA FE — Santa Fe Lumber & Millwork Inc. — (505 471-9022)

NEW YORK

ALBANY — Dorsey Millwork Inc. — (518 489-2542)

ALBANY — Iroquois Millwork Corporation — (518 436-9631)

BUFFALO — Iroquois Door Company — (716 856-8144)

DEER PARK (Long Island) — Sturtevant Millwork Corporation — (516 667-6700)

JOHNSON CITY — Robbins Door & Sash Co. — (607 797-1288)

RIDGEWOOD (Long Island) — Hussey-Williams Co. — (212 381-2500)

SYRACUSE — Iroquois Door Co. — (315 455-2491)

VICTOR (Rochester) — Iron City Sash & Door Company — (716 924-3201)

NORTH CAROLINA

CHARLOTTE — Huttig Sash & Door Company — (704 332-1503)

KERNERSVILLE — Huttig Sash & Door Company — (919 996-5221)

ROCKY MOUNT — Huttig Sash & Door Company — (919 446-2446)

NORTH DAKOTA

BISMARCK — The Radford Company — (701 223-5890)

FARGO — The Radford Company — (701 282-7200)

OHIO

CANTON — Iron City Sash & Door Company — (216 478-1461)

CINCINNATI — Acme Sash & Door Company — (513 242-4400)

COLUMBUS — Huttig Sash & Door Company — (614 486-4367)

DAYTON — Dayton Sash & Door Company — (513 224-0626)

NORTH LIMA (Youngstown) — Iron City Sash & Door Company — (216 549-9801)

TOLEDO — Allen A. Smith Co. — (419 537-1373)

VALLEY CITY — Weiler-Wilhelm Window and Door Co. — (216 225-9500)

OKLAHOMA

OKLAHOMA CITY — Lumbermen's Supply Co. — (405 232-9163)

TULSA — Mid-West Mill & Supply Co. — (918 747-2000)

TULSA — General Sash & Door Co. — (918 622-3131)

OREGON

BEAVERTON — Savage Wholesale Bldg. Materials, Inc. — (503 643-8505)

WILSONVILLE (Portland) — Sequoia Supply — (503 682-2822)

PENNSYLVANIA

ALLENTOWN — Reeb Millwork Corp. — (215 770-0700)

ALLENTOWN — Robbins Door & Sash Co., Inc. — (215 434-4827)

CARLISLE — Middle Atlantic Millwork Co. — (717 243-5656)

FRACKVILLE — Robbins Door & Sash Co., Inc. — (717 874-1220)

HARRISBURG — Robbins Door & Sash Co., Inc. — (717 238-8101)

MECHANICSBURG — C-E Morgan Distribution — (717 697-0346)

MONTOURSVILLE — Robbins Door & Sash Co. — (717 368-2656)

NORTH HUNTINGDON (Pittsburgh) — Shuster's Building Components — (412 863-4018)

SANDY LAKE — Iron City Sash & Door Co. — (412 376-7415)

SCRANTON — Robbins Door & Sash Co., Inc. — (717 344-6156)

WILKES-BARRE — Robbins Door & Sash Co. — (717 824-8781)

WINDBER (Johnstown) — Iron City Sash & Door Co. — (814 467-4571)

SOUTH CAROLINA

WEST COLUMBIA — C-E Morgan Distribution — (803 791-5634)

SOUTH DAKOTA

SIOUX FALLS — Jordan Millwork Company — (605 336-1910)

WATERTOWN — Jordan Millwork Company — (605 886-5801)

TENNESSEE

KINGSPORT — Holston Builders Supply — (615 247-8131)

MEMPHIS — Memphis Sash & Door Co. — (901 363-8040)

NASHVILLE — Wholesale Building Products — (615 259-4222)

TEXAS

AUSTIN — Davidson Texas, Inc. — (512 444-6701)

DALLAS — Lone Star Wholesale — (214 247-6161)

HOUSTON — Lone Star Wholesale — (713 680-3217)

LUBBOCK — Dea Window & Door Co. — (806 763-7078)

LUBBOCK — Lubbock Sash & Door Co. — (806 763-7695)

UTAH

SALT LAKE CITY — Diehl Lumber Products, Inc. — (801 972-8300)

VIRGINIA

ALEXANDRIA — C-E Morgan Distribution — (703 370-5740)

FREDERICKSBURG — Huttig Sash & Door Co. — (703 371-1710)

PORTSMOUTH — C-E Morgan Distribution — (804 393-4036)

ROANOKE — Huttig Sash & Door Co. — (703 344-6201)

WASHINGTON

SPOKANE — Exchange Lumber & Mfg. Co. — (509 487-1621)

TACOMA — Savage Wholesale Building Materials, Inc. — (206 383-1727)

WEST VIRGINIA

NITRO (Charleston) — Appalachian Sash & Door Co. — (304 755-8251)

WISCONSIN

LACROSSE — The Radford Company — (608 781-2280)

MILWAUKEE — Western Moulding Co., Inc. — (414 258-4686)

OSHKOSH — The Radford Company — (414 231-4880)

WINDSOR (Madison) — The Radford Company — (608 244-3962)

Isn't it time you had all the facts, right down to the last beautiful detail? Call your nearby Andersen distributor. Andersen Corporation, Bayport, MN 55003.

The beautiful way to save fuel®
Andersen Windowalls®

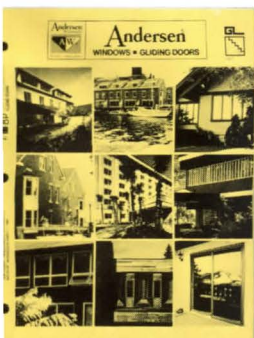

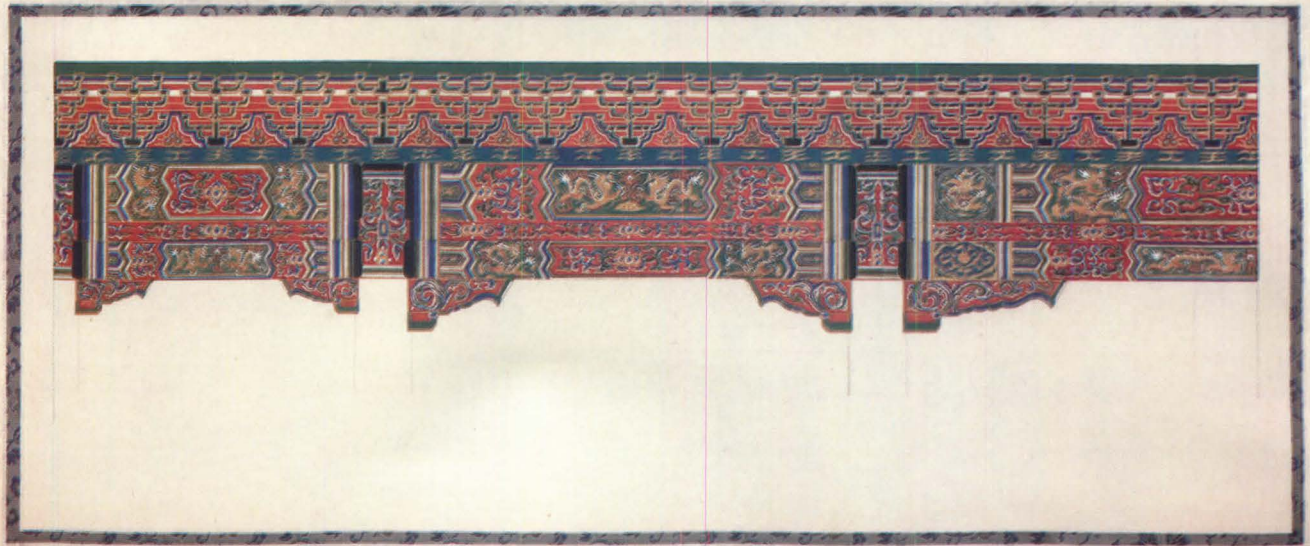

These Chinese ceiling designs and the one on the cover, produced by the Chu, Chin & Ling Studio (Soochow, China) were sent to the AIA JOURNAL in the 1940s. Apparently, P.T. Chu was an architect who practiced in Nanking for the 14 years prior to the Japanese invasion and destruction of that city. At that time his office and house were destroyed. In 1922,

he had received a scholarship in architecture and city planning, but was unable to study in the U.S. as planned because of poor health. In 1941, Chu established an art studio with a cousin and an aged uncle, a well known Chinese calligrapher and engraver, and began work on "A Polychrome Presentation of Chinese Architectural Decorations." *Nora Richter Greer*

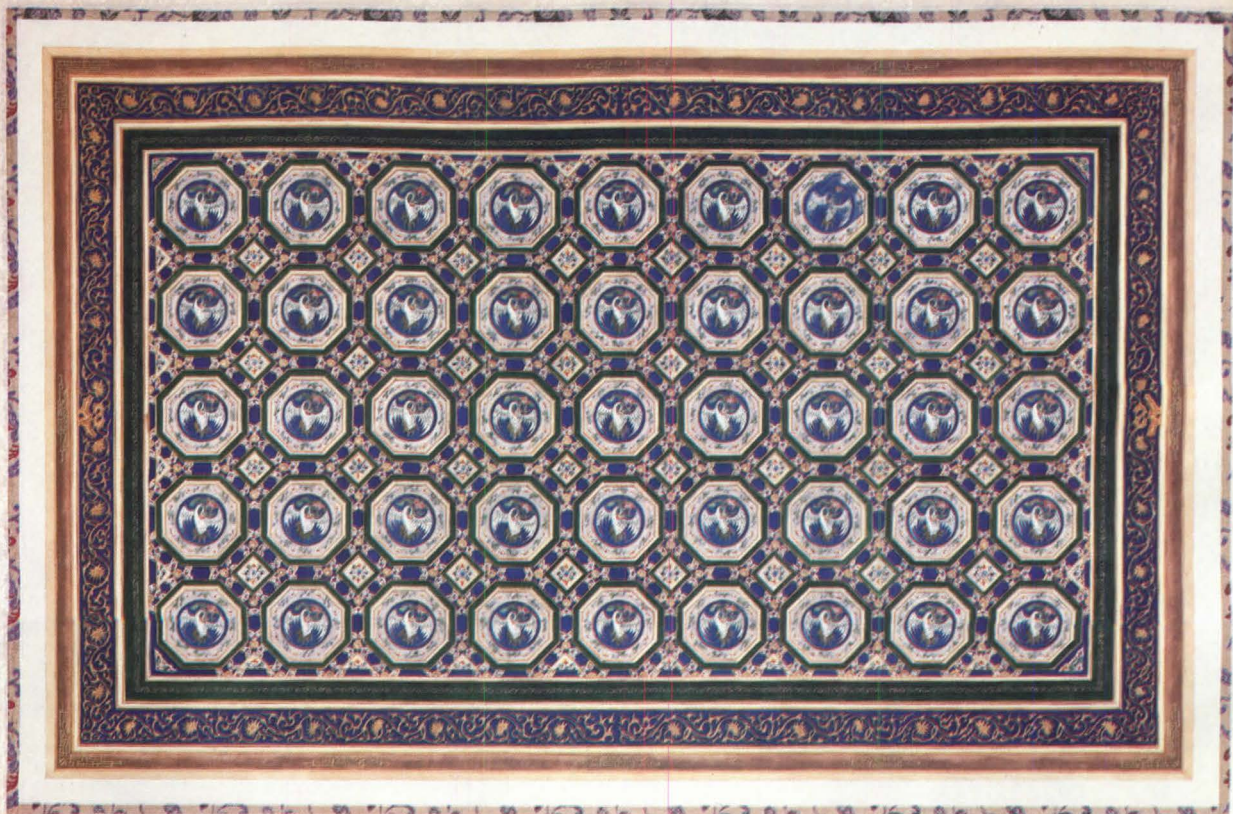

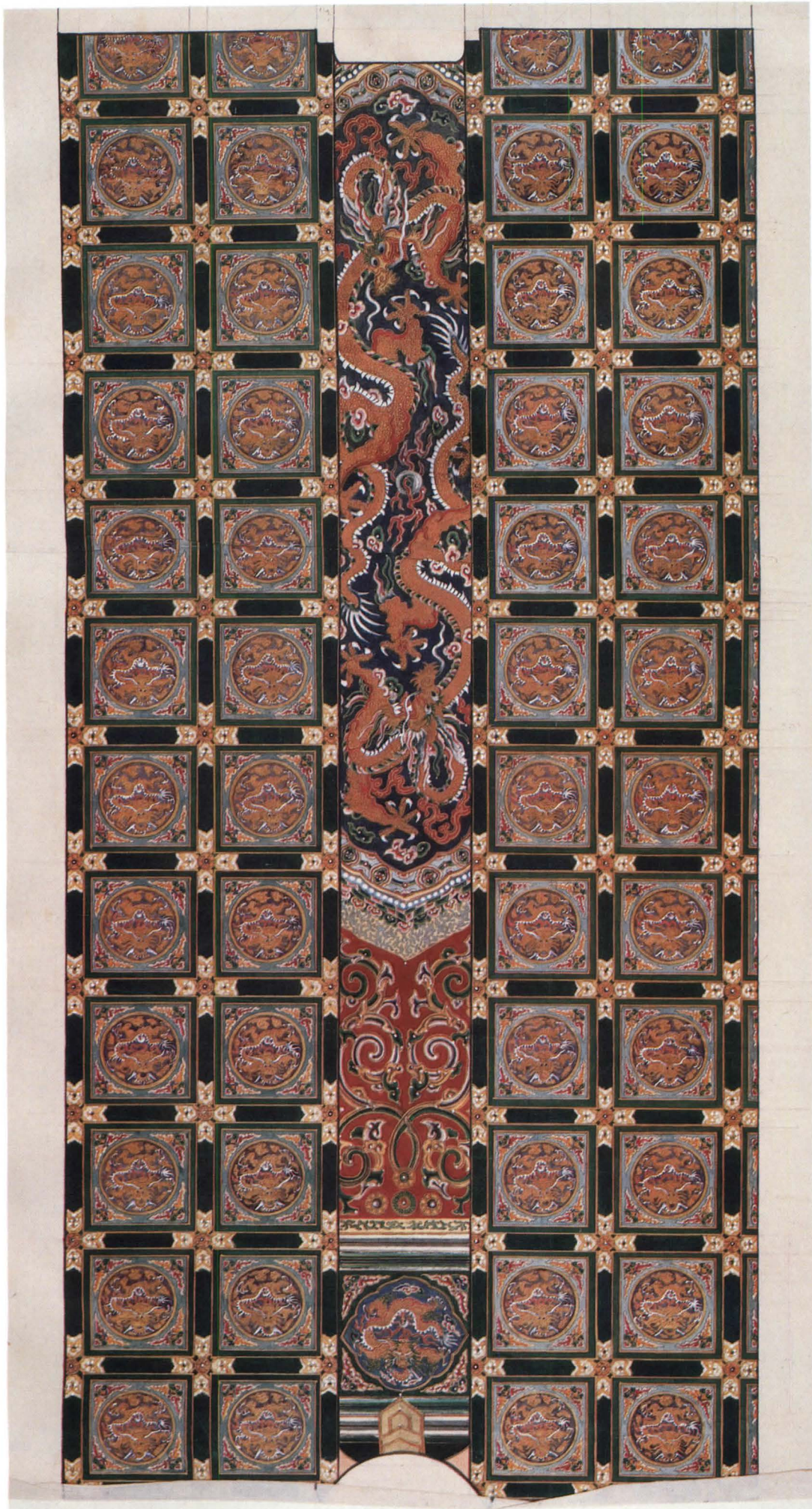

Drawings courtesy of the AIA Foundation, Prints and Drawings Collection

EXCLUSIVE DARK CURTAIN WALL SYSTEM BLOCKS FLAMES 10 TIMES LONGER THAN GLASS FIBER!

Now! Fire tests provide convincing proof: new THERMAFIBER® Dark Curtain Wall Insulation blocks flame spread at the spandrel—for over three hours—even at 1900°F. (ASTM E119 test procedure). After test was terminated, dark THERMAFIBER mineral wool remained solidly intact as did the total assembly. In the identical test, glass fiber insulation began to melt in 10 minutes at just 1200°F. Flames became visible at 16 minutes. Glass spandrel shattered in 17½ minutes to conclude testing. This new U.S.G. system offers you another important benefit: its exclusive dark color was developed expressly for vision glass curtain walls to eliminate insulation showthrough. Combine this unique dark curtain wall insulation with THERMAFIBER Saffing around perimeter and at all "poke through" utility openings to assure 3-hr. fire containment rating. ■ Call your U.S.G. Representative. Call us at (312) 321-4353. Or write to us at 101 South Wacker Drive, Chicago, Illinois 60606, Dept. AIA881

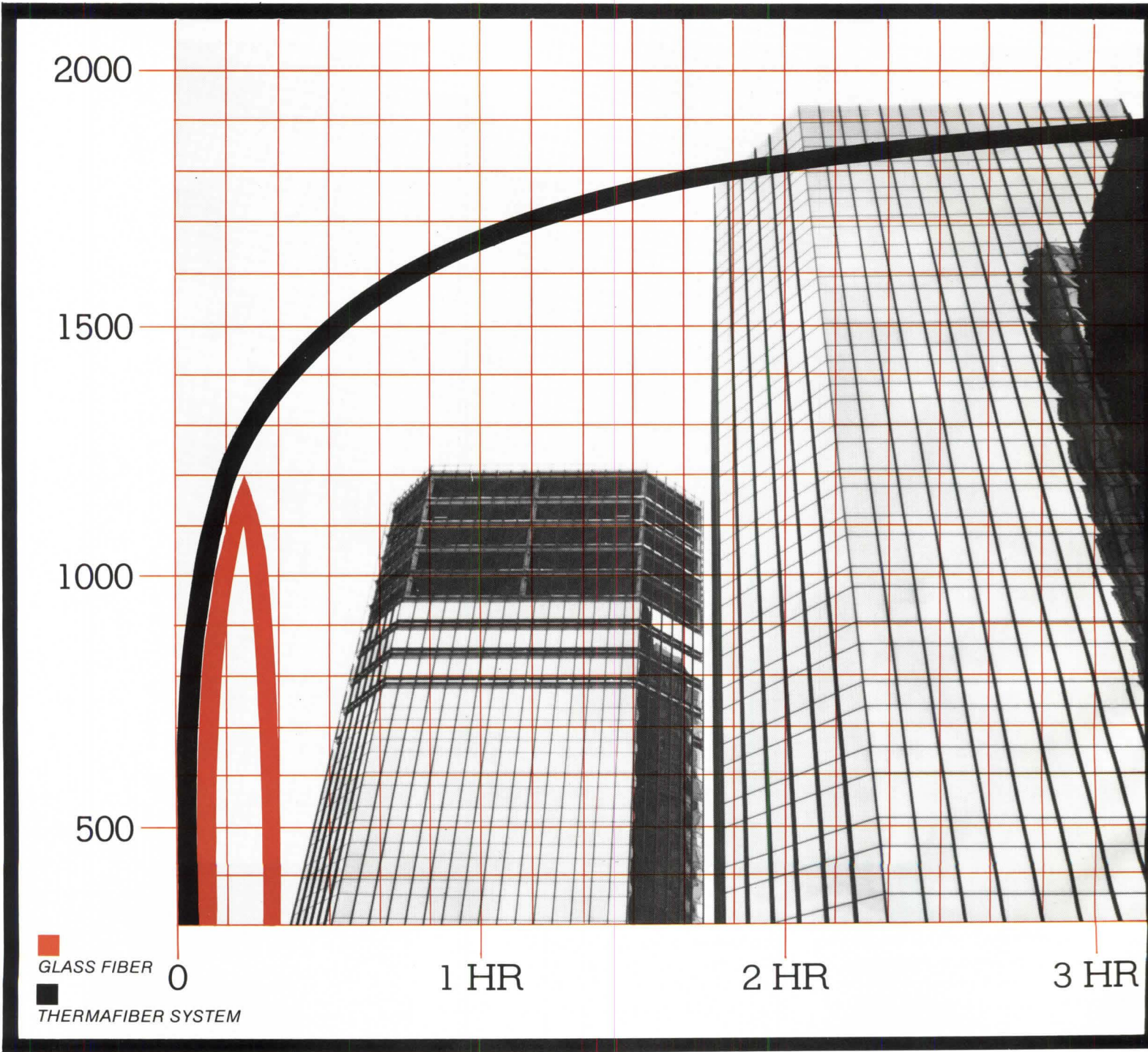
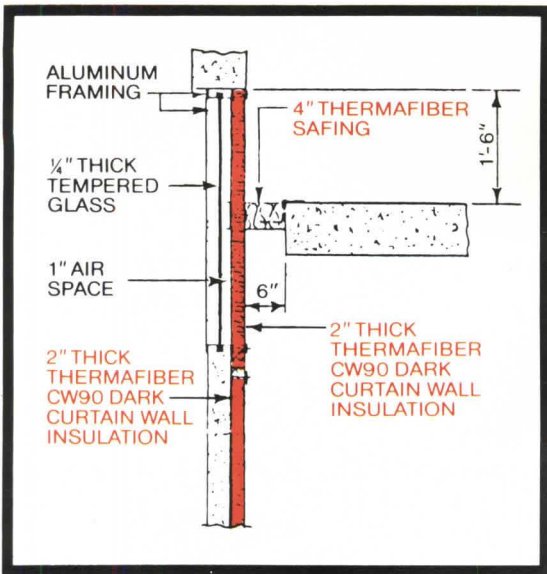

The Basic Workings of the Institute

The AIA's activities and programs are developed and guided by the board of directors, officers and commissions; individual AIA members play key roles in policy-making through service on various committees.

The system works like this. A member or a committee may wish to develop a particular Institute policy or establish a particular program. The committee makes a preliminary investigation of the matter and forwards its recommendations through the appropriate commission (made up of AIA directors) to the board for development approval. Upon approval, the committee then makes a thorough review of the matter and returns it to the commission. It is then forwarded to the board for approval, termination or revision. Upon board approval, implementation of a policy is turned over to the government affairs department and implementation of a program over to the appropriate AIA department.

Basically, each department provides staff support for the various committees. And each department and committee is overseen by a commission of four to seven board members.

The board, which also adopts the Institute's general budget, consists of the president, first vice president, treasurer, secretary, three vice presidents, executive vice president (who serves *ex officio*), the public director, 32 directors elected from 18 regions, the president of the Association of Student Chapters/AIA (*ex officio*) and the chairperson of the council of architectural component executives. It meets five times a year.

Supervision of the Institute's staff is the responsibility of the executive office, which includes the executive vice president, David Olan Meeker Jr., FAIA, and staff assistants for policy planning and research. The executive vice president is appointed by and responsible to the board and serves as president of the AIA Corporation, as vice chairperson of the board of the AIA Research Corporation and as an assistant treasurer of the AIA.

The following departments are supervised by the executive office:

- The assistant secretary's office, headed by James A. Schuping, supports the Institute's elected secretary through a variety of programs. It administers membership procedures, coordinates AIA's award programs, assists the Institute by carrying out obligations outlined in the bylaws, handles international relations and provides staff support for the design/build/contracting monitoring task force.

- The general counsel, Alan B. Stover,

AIA, acts as internal counsel and general adviser to the Institute and its related corporations and supervises the work of outside corporate counsel and other specialized outside legal counsel.

- The business management department, headed by William G. Wolverton, Hon. AIA, administers or monitors the business affairs of the Institute and its related corporations. Specific functions include accounting, building management, data processing, personnel, purchasing and shipping and receiving.

- The program and services management group executive, James A. Scheeler, FAIA, coordinates the activities of the convention/conferences/special events, design, education and professional development, government affairs, library, member/component affairs, practice, public relations and publications departments. The group executive also maintains liaison with other professional design and construction groups.

- Convention/conferences/special events, headed by Francis X. Brown, is responsible for the organization and implementation of the annual convention. It also handles logistics for conferences such as Grassroots, COFPAES and others and is responsible for all meetings, special events and catering functions held at the Institute.

- The design department, directed by Michael B. Barker, AICP, administers all AIA activities, programs and products that are primarily concerned with design excellence. The fundamental responsibilities of the department are to increase the architect's skill in design through publications, conferences and programs and to stimulate the demand for architectural quality among clients.

- Education and professional development, headed by James E. Ellison, AIA, encourages development of the "most capable new professionals" by fostering quality education, by providing training and internship programs and by monitoring professional examination procedures.

- Government affairs, Arnold J. Prima Jr., AIA, administrator, prepares and promotes Institute policy in government programs and activities to Congress, federal agencies, state and local governments, international agencies and the White House.

- The library, headed by Stephanie Byrnes, provides reference, audiovisual and loan services to AIA members, Institute staff and the general public. Its collection includes over 20,000 books, more than 350 current periodicals, an extensive

continued on page 47



**IF YOU THINK
LEVI'S® JEANS
ARE TOUGH,
YOU SHOULD SEE
THEIR NEW
600,000 SQ. FT.
ROOF.**

When an architect designs a building for a company that has built its reputation on toughness and durability, there's no way to stop short of the best.

That's just one of the reasons the roofing specs on Levi Strauss & Co.'s gigantic new Waco, Texas distribution center called for Celotex Glass Mat and Asphalt. These fiberglass ply sheets have an even distribution of fibers which makes for uniform porosity. During application, the asphalt bleeds through evenly to yield the most desirable interply bond between the Celotex Glass Mat and the asphalt.

The other reasons for specifying Celotex Glass Mat and Asphalt were the speed and ease of installation. Using a nine-man crew, plus three men for graveling, the contractor was able to cover the equivalent of 12½ football fields in only 60 days.

Celotex Glass Mat and Asphalt meets ASTM 2178 Type IV requirements, the most stringent of all. It is approved for all sections of the country.

For more information on Celotex Glass Mat and Asphalt or our full line of Built-Up Roofing products, contact Peter G. Nazaretian at The Celotex Corporation, Roofing Products Division, P.O. Box 22602, Tampa, Florida 33622. (813) 871-4584.

For more information on Celotex Glass Mat and Asphalt, contact your local distributor or call 1-800-368-7272. Celotex Glass Mat and Asphalt is a registered trademark of Celotex Corporation. © 1994 Celotex Corporation. All rights reserved.

CELOTEX
GLASS
MAT AND ASPHALT

CONTENTS—520
One roll contains 520 sq. ft. of roofing material.

CELOTEX
GLASS
MAT AND ASPHALT

Celotex
ROOFING PRODUCTS DIVISION

Celotex Glass Mat and Asphalt

Celotex

a JIM WALTER COMPANY

Circle 23 on information card

The Institute from page 45

slide collection, a number of rare books and the AIA archives.

- Member/component affairs, headed by John Wilson-Jeronimo, provides to state and local components programs and program information, organizational and leadership training, membership expansion and retention and Institute services. It also administers the Institute's affirmative action program and the committees for members in the practice areas of government, industry and education.

- The practice department, headed by Robert Packard, AIA, develops practice tools to improve the profession's competence and efficiency and administers the Institute's energy programs.

- The major objective of the public relations department, directed by Muriel Campaglia, is generating public awareness about architecture and the AIA.

- The publications department, headed by David Godfrey, provides services, materials and equipment for the production, marketing and delivery of publications that either originate with the Institute or that are sold through the Institute. It also administers the production, circulation and subscription sales functions of the AIA JOURNAL.

- The AIA JOURNAL, which is published 14 times a year, is the Institute's principal periodical contribution to the literature of the profession.

There are four subsidiary corporations of the AIA: the AIA Foundation, the AIA Research Corporation, the AIA Corporation and Production Systems for Architects & Engineers, Inc.

The AIA Foundation is a nonprofit educational institution that solicits, receives and expends gifts, grants and legacies to provide architectural scholarships, establish professorships, assist research projects and establish awards. It maintains the Octagon as a historic house museum and presents frequent exhibitions there, chiefly concerned with the preservation and history of architecture. It has also received grants to provide for the conservation and storage of the architectural records of Richard Morris Hunt.

The AIA Research Corporation was established in 1972 as a nonprofit organization to perform applied research on issues of national significance affecting the built environment. Its support comes primarily from contracts and grants from government agencies, private industry and foundations.

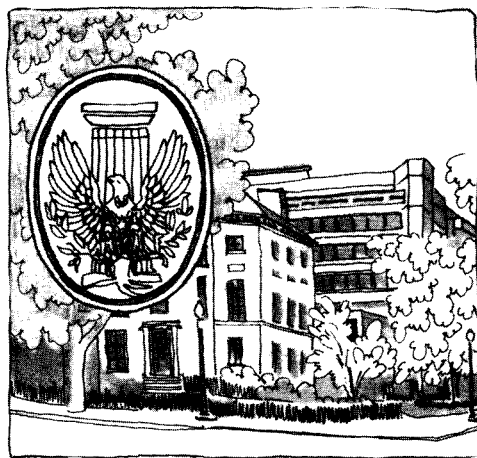

The AIA Corporation, a District of Columbia taxable business corporation, owns and operates the AIA building. All of the corporation's stock is owned by AIA.

Production Systems for Architects & Engineers, Inc., is a wholly owned taxable corporation of AIA, charged with developing, producing and operating production systems for A/Es based on systemizing repetitive practices. Two major programs are in operation: Masterspec, a nationwide automated master specification system, and CFMS (Computer-based Financial Management Service), an automated management and accounting systems/service.

OFFICERS

(December 1980-December 1981)

President

R. Randall Vosbeck, FAIA
720 N. St. Asaph St.
Alexandria, Va. 22314
(703) 549-9200

First Vice President

Robert M. Lawrence, FAIA
101 Park Ave. Building, #1313
Oklahoma City, Okla. 73102
(405) 272-0405

Vice President

Robert C. Broshar, FAIA
900 Waterloo Building
Waterloo, Iowa 50701
(319) 233-8419

Vice President

George M. Notter Jr., FAIA
77 N. Washington St.
Boston, Mass. 02114
(617) 227-9272

Vice President

Ray K. Parker, AIA
1 Spring St.
Little Rock, Ark. 72201
(501) 372-2900

Secretary

Harry Harmon, FAIA
650 Edity Way
Long Beach, Calif. 90807
(213) 590-5512

Treasurer

Jay W. Barnes, FAIA
1600 W. 38th St., Suite 100
Austin, Tex. 78731
(512) 451-8281

Executive Vice President

Ex Officio

David Olan Meeker Jr., FAIA
1735 New York Ave. N.W.
Washington, D.C. 20006
(202) 626-7310

DIRECTORS

(Year term expires)

California

George A. Bissell, FAIA (1983)
190 Newport Center
Newport Beach, Calif. 92660
(714) 644-5670

William Blurock, FAIA (1982)
2300 Newport Boulevard
Newport Beach, Calif. 92660
(714) 673-0300

James C. Dodd, AIA (1981)
2710 X St.
Sacramento, Calif. 95818
(916) 452-6411

J. Peter Winkelstein, FAIA (1983)
243 Vallejo St.
San Francisco, Calif. 94111
(415) 788-2644

Central States

R. Bruce Patty, FAIA (1982)
825 Wyandotte
Kansas City, Mo. 64105
(816) 474-6910

Henry W. Schimer, AIA (1981)
3715 S.W. 29th St.
Topeka, Kan. 66614
(913) 273-1361

East Central States

P. Whitney Webb, AIA (1982)
P.O. Box 419
104 Esplanade
Lexington, Ky. 40585
(606) 253-2456

Florida/Caribbean

Ellis W. Bullock Jr., AIA (1981)
1823 N. Ninth Ave.
Pensacola, Fla. 32503
(904) 434-5445

E. H. McDowell, FAIA (1981)
P.O. Box 3958
St. Thomas, V.I. 00801
(809) 744-5373

continued on page 48

The Institute from page 47

Gulf States

William H. Beaty, AIA (1983)
147 Jefferson Ave.

Suite 1212

Memphis, Tenn. 38103

(901) 525-6663

Gaines B. Hall, AIA (1981)

1001 W. Main St.

Box 1614

Dothan, Ala. 36302

(205) 794-7558

Illinois

Raymond C. Ovresat, FAIA (1981)

435 N. Michigan, Suite 1515

Chicago, Ill. 60611

(312) 644-3464

Michigan

John W. Jickling, FAIA (1983)

909 Haynes St.

Birmingham, Mich. 48011

(313) 647-1777

Middle Atlantic

Theodore F. Mariani, AIA (1983)

1600 20th St. N.W.

Washington, D.C. 20009

(202) 462-5656

James R. Nelson, AIA (1981)

504 W. 10th St.

Wilmington, Del. 19801

(302) 652-3576

New England

John Avery Carter, AIA (1982)

4 Church St.

Nashua, N.H. 03060

(603) 883-6443

Robert J. von Dohlen, AIA (1983)

281 Farmington Ave.

P.O. Box H

Farmington, Conn. 06032

(203) 677-8556

New Jersey

Romeo Aybar, AIA (1983)

605 Broad Ave.

Ridgefield, N.J. 07657

(201) 943-1717

New York

Joseph Monticciolo, AIA (1982)

U.S. Dept. of HUD, Region II

26 Federal Plaza

New York, N.Y. 10278

(212) 264-4376

William A. Rose Jr., AIA (1981)

44 S. Broadway

White Plains, N.Y. 10601

(914) 682-4862

North Central

Leroy Bean, AIA (1982)

335 N. Main Ave.

Sioux Falls, S.D. 57102

(605) 339-1711

Northwest

Edwin B. Crittenden, FAIA (1981)

801 W. Fireweed Lane

Anchorage, Alaska 99503

(907) 272-3567

David A. Pugh, FAIA (1983)

900 S.W. Fifth Ave.

Portland, Ore. 97204

(503) 226-1431

Ohio

Robert Gramann, AIA (1982)

6703 Madison Road

Cincinnati, Ohio 45227

(513) 271-7800

Pennsylvania

Derek Martin, AIA (1981)

100 Ross St.

Pittsburgh, Pa. 15219

(412) 471-6150

South Atlantic

John A. Busby Jr., FAIA (1982)

909 W. Peachtree St. N.W.

Atlanta, Ga. 30309

(404) 892-2890

Richard A. McGinty, AIA (1983)

11 Lagoon Road

Hilton Head, S.C. 29928

(803) 785-2444

Texas

William Caudill, FAIA (1982)

1111 W. Loop S.

Houston, Tex. 77027

(713) 621-9600

Theodore S. Maffitt Jr., FAIA (1982)

510 N. Sycamore

Palestine, Tex. 75801

(214) 729-2433

Pat Y. Spillman, FAIA (1981)

3204 Fairmount

Dallas, Tex. 75201

(214) 748-6488

Western Mountain

Thomas B. Muths, AIA (1981)

P.O. Box FF

Jackson, Wyo. 83001

(307) 733-4217

John B. Rogers, FAIA (1981)

1576 Sherman

Denver, Colo. 80202

(303) 832-5599

Student Director,

Ex Officio

President, ASC/AIA

William Plimpton

1735 New York Ave. N.W.

Washington, D.C. 20006

(202) 626-7472

**Chairwoman, Council of Architectural
Component Executives, Ex Officio**

Ann Stacy, Hon. AIA

Michigan Society of Architects

553 E. Jefferson

Detroit, Mich. 48226

(313) 965-4100

Public Director

Robert B. Pease, Hon. AIA

3018 One Oliver Plaza

Pittsburgh, Pa. 15222

(412) 281-1890

dryvit SYSTEM,
INC.
OUTSULATION

**Retrofit over a
brick substrate.**

In the First Alabama Bank retrofit (facing page), the problem of a crumbling brick facade presented itself. After the brick was given a thorough chemical cleaning, the Dryvit Insulation Board was affixed directly to the brick substrate.

This application has been used successfully in many retrofits with Dryvit Outsulation.

Look for Dryvit in the General Building File of Sweets Catalog under Section 7.13/Dr.

Wall section detail below:

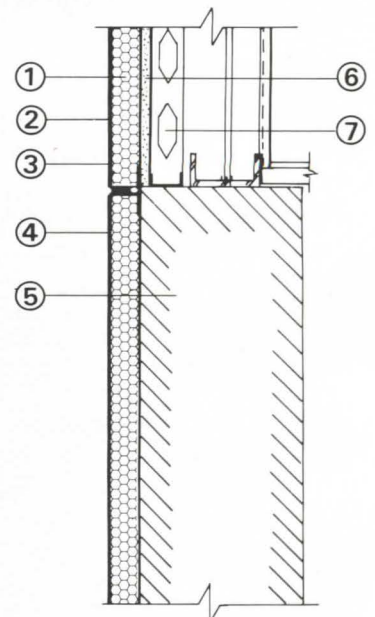

- 1. Dryvit Insulation Board:** expanded polystyrene with optimum insulating characteristics. Board sizes, thicknesses and shapes are available as required by design.
- 2. Dryvit Reinforcing Mesh:** specially woven and treated fiberglass fabric is embedded in the Primus coating to prevent surface cracking.
- 3. Dryvit Primus™/Adhesive:** Dryvit's unique plaster material mixed with Type 1 Portland Cement is used to adhere Dryvit Insulation Board to the approved substrate. It is also used to embed Dryvit Reinforcing Mesh on the face of the board.
- 4. Dryvit Quarzputz™ Finish:** one of four finishes available. This synthetic plaster material has high bond strength, integral color and an applied texture that provides a weather-proof jointless exterior surface.
- 5. Existing Brick** (chemically cleaned)
- 6. 1/2" Exterior Gyp. Sheathing**
- 7. 2 1/2" Steel Studs @ 16" O.C.**

DRYVIT SYSTEM, INC.
420 Lincoln Avenue, Warwick, RI 02888
(401) 463-7450
Plant Locations:
Warwick, RI; Tulsa, OK; Columbus, GA

®
 C
 O
 U
 T
 S
 U
 L
 A
 T
 I
 O
 N

Outsulation® turns a turn-of-the-century energy-waster into a bank for the '80s.

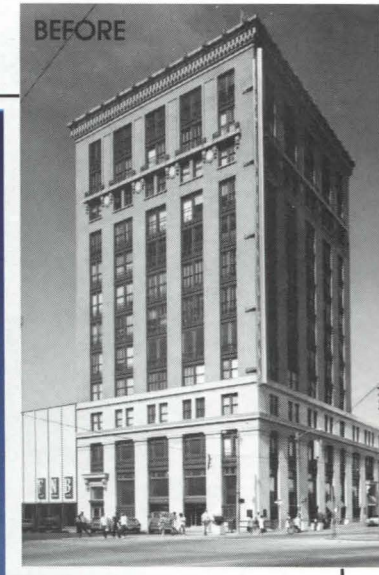

ARCHITECT: Pearson, Tittle, Narrows & Assoc.

What do you do with a valuable piece of 70-year old real estate that's out of step with its contemporary neighbors? The architects charged with the retrofit of the First Alabama Bank in downtown Montgomery, faced a variety of problems.

Foremost among them were high energy costs, a deteriorating brick exterior (circa 1906) and a down-at-heels image.

Liabilities were changed into assets by retrofit with Dryvit Outsulation.

By placing Outsulation over the brick, massive insulation sealed thermal bridges, minimized thermal stress and produced substantial energy savings (approx. 50% in heating and 40% in cooling).

At the same time, Outsulation added a modern permanent exterior surface. An exterior that is maintenance-free, crack and stain-resistant. An exterior very much at home with the new buildings around it.

What's more, to top off the additional height needed for signage, Outsulation provided the perfect lightweight parapet wall.

Outsulation adds a lot more than energy savings to this bank's retrofit. And it can do more for yours. Thousands of successful examples stand across the nation. Let us prove its worth to you.

Call or write, stating your application: new construction or retrofit.

dryvit®

Dryvit System, Inc.

420 Lincoln Avenue, Warwick, RI 02888 (401) 463-7150 • Plant Locations: Warwick, RI; Tulsa, OK; Columbus, GA

Circle 24 on information card



THE SCHOOL BOARD ASKED FOR A BARGAIN. ACME BRICK GAVE THEM MORE THAN THEY BARGAINED FOR.

Loadbearing Acme Brick were selected for the Barling Elementary School for Fort Smith, Arkansas. Its curved walls at every corner were accomplished by a very simple factory modification to standard king-size brick. The double wythe wall provides its own finish surface, both inside and out. A wall, that for the life of the school has been, and will continue to be, totally maintenance-free. Maintenance and energy costs have been further reduced by limiting the number of exterior windows. Glass breakage has been reduced to an absolute minimum.

Miles Shopfner, Director of Maintenance and Purchasing, Fort Smith Public Schools: "Glass breakage savings alone can justify the selection of brick." He further added, "Our average school interior needs to be completely repainted every ten years, or even more often. This is eliminated at Barling. And besides, the building is less costly construction-wise."

Fire safety is another factor all parents and school officials are concerned with. Walls of Acme Brick are totally fire-resistant. Principal Rex Cochran: "The fire drill is an exercise we really don't need — with walls that just can't burn."

In this school's seven-year life, the 200,000 Acme Brick have paid for themselves several times over by savings to the School District and the people of Fort Smith, Arkansas.

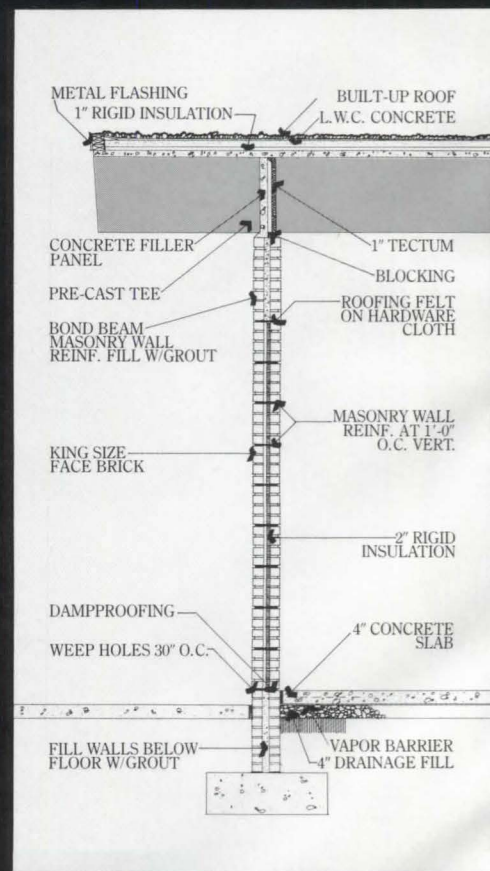

For more information on Acme Brick's Loadbearing Design, and for cost data on Barling Elementary School, call collect (817) 332-4101, ext. 365. Or write Acme Brick Technical Services, P.O. Box 425, Fort Worth, Texas 76107.

ACME BRICK. THE BEST ALL-AROUND BUILDING MATERIAL.

Barling Elementary School
 Owner: Special School District of Fort Smith, Fort Smith, Arkansas
 Architect: Saxton Wanslow Smith Associates, Fort Smith, Arkansas
 Structural: Burrough-Uerling-Brasuell, Engineers, Fort Smith, Arkansas
 General Contractor: Gary Crawford Construction Co., Fort Smith, Arkansas
 Masonry Contractor: Ronald Ray Masonry Contractor, Fort Smith, Arkansas



**Only for HPS.
Only from ITT.
The HPS Cutoff Luminaire.**

Only ITT built a cutoff luminaire around an HPS lamp. To give you a new HPS Cutoff Luminaire that is photometrically and mechanically superior to ordinary cutoff luminaires. Ours was designed specifically to precisely control and convey HPS light—the energy-efficient light source. Ours is the good looking way to put light where you want it. The flat cutoff unit was meticulously engineered to dramatically reduce hot spots and dark areas. And give you improved surface visibility.

Its one-piece reflector and one-piece die-cast housing make easy work of installation, maintenance, and cleaning. It opens with a simple one-hand latch, and there are no seams to collect dirt. It's available in 70 through 400 watt units. The ITT HPS Cutoff Luminaire uses HPS energy so masterfully, it has a 70% luminaire efficiency. In a typical area lighting application, the HPS Cutoff Luminaire yields 10% higher average illumination with a 10% higher minimum illumination point.

So if you're looking for an area luminaire that is quality constructed, uses HPS energy efficiently, and is aesthetically appealing, you've found it. Write for our free complete catalog: ITT Outdoor Lighting, Box 100, Dept. M8, Southaven, MS 38671. Or call 601-342-1545.

ITT OUTDOOR LIGHTING

Circle 26 on information card

The following is a key word index, a quick reference for finding the AIA or affiliated organization staff member who can answer your questions. Telephone numbers begin with 626 unless noted. The area code is 202. AIA's hotline is (202) 626-7554.

Subject	Staff	Telephone
Accident Insurance	William G. Wolverton, Hon. AIA	7322
Accounting Office	Ronald J. Panciera	7325
Accounting System, Computerized (PSAE)	John H. Schruben, FAIA	7369
Accreditation of Architectural Schools	Karen Bradbury, NAAB	783-2007
Advertising by National AIA	James E. Ellison, AIA	7347
Advocacy	Muriel Campaglia	7459
A/E Selection, National Government	Beverly Sanchez	7434
A/E Selection, State	Arnold J. Prima Jr., AIA	7374
Affirmative Action	Elizabeth Chalmers	7385
Agreements (AIA Forms) Interpretations	Beverly Sanchez	7434
Orders/Sales	Douglas DuCharme	7309
AIA Corporation, President	Terry L. Peck	7485
AIA Filing System	David O. Meeker Jr., FAIA	7310
AIA Foundation	William Hooper, AIA	7457
President	Jeanne Butler Hodges	638-3105
The Octagon		638-3105
AIA Journal		
Circulation	Brenda Owens	7327
Editor	Donald Canty	7477
Marketing Director	Michael Wood	7482
Production Manager	Jesse Sims	7484
Publisher	Michael J. Hanley	7470
AIA Minority/ Disadvantaged Scholarship Program	Yina A. Moore	7349
AIA Political Action Committee	Stanley E. Kolbe	7379
AIA Production Systems for Architects & Engineers (PSAE) President	John H. Schruben, FAIA	7369
AIA Research Corporation		7500
President	Charles R. Ince Jr.	7508
AIA Scholarship Program	Yina A. Moore	7349
AIA Standard Documents Interpretation	Dale Ellickson, AIA	7440
Orders/Sales	Terry L. Peck	7485
Annual Committee Reports	James A. Schuping	7502
Arbitration	Dale Ellickson, AIA	7440
Architect/Engineer Liaison	James A. Scheeler, FAIA	7315
Architect/Owner Relations	Dale Ellickson, AIA	7440
Architect's Handbook of Professional Practice Orders/Sales	Dale Ellickson, AIA	7440
Architects in Education	Terry L. Peck	7485
Architects in Government	Beverly Sanchez	7434
Architects in Industry	Beverly Sanchez	7434
Architects Liability Committee	William Hooper, AIA	7449
Architectural Education Counseling	Yina A. Moore	7349
Architectural Graphic Standards	William Miner, AIA	7307
Order/Sales	Kathie Davis	7474
Architectural Secretaries Association	Bette Callet	7376

Subject	Staff	Telephone
Architectural Study Tours	Syed Ali	7467
Architectural Training Labs	Suzon Loomis	7355
Archives, Institute	Tony P. Wrenn	7496
Arts and Recreation, Architecture for the Programs	Professional Interest	7364
ASHRAE	David C. Bullen, AIA	7448
Associate Members	Bette Callet	7376
Associated General Contractors	Dale Ellickson, AIA	7440
Association of Architectural Librarians	Stephanie Byrnes	7494
Association of Collegiate Schools of Architecture (ACSA) Executive Director	Richard McCommons	785-2324
Association of Student Chapters	William J. Plimpton	7472
Audio Tape Cassettes	Nora Klebow	7472
Audiovisual Materials	Publications Fulfillment	7332
Awards Programs	Jacklyn DeRieux	7495
Baldwin Memorial Archives Library	Maria Murray, Hon. AIA	7390
Barrier-Free Architecture	Henry J. Lawrence	7493
Benefit Insurance	William G. Wolverton, Hon. AIA	7427
BEPS	David C. Bullen, AIA	7322
Bibliographies, Requests for Library		7448
Board of Directors	James A. Schuping	7493
Bonds	Dale Ellickson	7502
Building Codes & Regulations	Dale Ellickson	7440
Building Security	Henry J. Lawrence	7427
Building Standards	Henry J. Lawrence	7427
Building Types & Design	Professional Interest Programs	7364
Business Management Dept.	William G. Wolverton, Hon. AIA	7332
Bylaws (Institute)	James A. Schuping	7502
Bylaws (Component)	Betty Musselman	7389
CACE		7378
Careers in Architecture	Yina A. Moore	7349
Cases, Legal Citations	Dale Ellickson, AIA	7440
Catering Services (headquarters)	Shelly Getchell	7398
Change of Address	Tom Ainsworth	7335
Clearinghouse of State Legislation	Elizabeth Chalmers	7385
Code of Ethics and Professional Conduct	James A. Schuping	7502
Codes and Standards	Henry J. Lawrence	7427
College of Fellows	Syed Ali	7467
Commerce & Industry, Architects for Programs	Professional Interest	7364
Committee on Federal Procurement of A/E Services (COFPAES)	Arnold J. Prima	7374
Committees, AIA	Frank Musica	7382
Community Design Center Program (CDC)	James A. Schuping	7502
Community Services	John Gaillard	7363
Compensation Management	William Hooper, AIA	7457
Competitions, Architectural	William Lehr	7362
Competitive Bidding	Elizabeth Chalmers	7385
Component Affairs Chapter	Bette Callet	7378
State	Bette Callet	7376
Component Clearinghouse	Elizabeth Chalmers	7385
Component Officers	Bette Callet	7377
Planning Guide	Bette Callet	7376

Subject	Staff	Telephone
Component President's Letter	Bette Callet	7377
Component Profile	Bette Callet	7376
Component Public Relations Assistance	Joy Brandon	7464
Conference on Federal Agency Construction Programs	Frank Musica	7382
Congressional Liaison	Stanley Kolbe	7379
Construction Contract Administration	Dale Ellickson, AIA	7440
Construction Management/Design Build	William Hooper, AIA	7457
Construction Products Manufacturers Council Liaison	James A. Scheeler, FAIA	7315
Consumer Products Safety Commission	Henry J. Lawrence	7427
Continuing Education Program	Cameron Tucker, AIA	7354
Contractor-Architect Relations	Dale Ellickson, AIA	7440
Contractors Liaison	Dale Ellickson, AIA	7440
Contracts and Forms Interpretations	Dale Ellickson, AIA	7440
Orders/Sales	Terry L. Peck	7485
Controller	William G. Wolverton, Hon. AIA	7322
Convention, AIA	Frank X. Brown	7395
	Ketchie Brassel	7396
	Syed Ali	7467
	Douglas DuCharme	7309
Copyrights (AIA Documents)		
Corporations	Dale Ellickson, AIA	7440
Cost-Based Compensation	William Hooper, AIA	7457
Council of Architectural Component Executives		7378
Council of Black Architectural Schools	Yina A. Moore	7349
Current Techniques in Architectural Practice	William Hooper, AIA	7457
Data Processing	Tom Ainsworth	7335
Design-Build/Construction Management	William Hooper, AIA	7457
Design Competitions		
General	William Lehr	7362
AIA	Maria Murray, Hon. AIA	7390
Student	William Plimpton	7472
Design Department	Michael Barker, AICP	7360
Design Programs	Michael Barker, AICP	7360
Dimensional Coordination	Douglas DuCharme	7309
Disability Insurance	William G. Wolverton, Hon. AIA	7332
Documents Committee	Dale Ellickson, AIA	7440
Documents Subscription Service		
Interpretations	Douglas DuCharme	7309
Orders/Sales	Terry L. Peck	7485
Dues (AIA Membership)	Ronald J. Panciera	7325
Education, Architecture for	Professional Interest Programs	7364
Education and Professional Development	James E. Ellison, AIA	7347
Education Fellowships and Grants	Yina A. Moore	7349
Emblem of the Institute	James A. Schuping	7502

Contacts for Help at AIA

Subject	Staff	Telephone	Subject	Staff	Telephone
Energy, Codes and Standards	Henry J. Lawrence	7427	In-Hospital Insurance	William G. Wolverton, Hon. AIA	7322
Energy Committee	David C. Bullen, AIA	7448	Industry, Architects in Insurance	Beverly Sanchez	7434
Energy/Government Affairs	Mary Ann Eichenberger	7503	Benefit	William G. Wolverton, Hon. AIA	7322
Energy Information	John R. Hoke Jr., AIA	7458	Liability	William Hooper, AIA	7457
Energy Network	John R. Hoke Jr., AIA	7458	Interior Architecture/Design	Professional Interest Programs	7364
Energy Professional Development Program	Cameron Tucker, AIA	7354	Interior Design Documents	Dale Ellickson, AIA	7440
Energy Publications	Brenda Henderson	7353	Intern-Architect Development Program (IDP)	Linda Oktayüren	7353
Energy Research	Kathie Davis	7474	Intern-Architect Supplementary Education Program	Linda Oktayüren	7353
Engineer-Architect Interprofessional Relations	Charles R. Ince, Jr.	7508	International Architects/Agencies	Kathleen Knepp	7549
Environmental Design, Interprofessional Council	James A. Scheeler, FAIA	7315	International Competitions	William Lehr	7362
Environmental Education	Alan R. Sandler	7573	International Practice	Frank Musica	7382
Environmental Policies	John Gaillard	7376	International Relations	Kathleen Knepp	7549
Equal Employment Opportunity	Sheila Neary	7324	Internship Activities	Linda Oktayüren	7353
Errors and Omissions Insurance	William Hooper, AIA	7457	Interprofessional Council on Environmental Design	James A. Scheeler, FAIA	7315
Ethics	James A. Schuping	7502	Joint Venture	Beverly Sanchez	7434
Executive Committee Meetings	James A. Schuping	7502	Justice, Architecture for	Professional Interest Programs	7364
Executive Vice President	David O. Meeker Jr., FAIA	7310	Labor Liaison	Arnold J. Prima Jr., AIA	7374
Executives, Component		7378	Legal Citator	Douglas DuCharme	7309
Fellows Program	Maureen Marx, Hon. AIA	7392	Legal Counsel	Alan B. Stover, AIA	7388
Filing System, Product Literature	William Miner, AIA	7307	Legal Questions		
Film Sales/Loans	Library	7495	Documents, Practice, Liability	Dale Ellickson, AIA	7440
Financial Management	William Hooper, AIA	7457	Local and State Government	Elizabeth Chalmers	7385
Financial Officer of AIA	William G. Wolverton, Hon. AIA	7322	Institute Legal Matters	Alan B. Stover, AIA	7391
Firesafety in Buildings	Henry J. Lawrence	7427	Legislation, Evaluation and Assistance (Energy)	David C. Bullen, AIA	7448
Five Presidents' Council	James E. Ellison, AIA	7347	Legislation, National Department	Mary Ann Eichenberger	7503
General Conditions	Dale Ellickson, AIA	7440	Legislation, State	Government Affairs	7374
General Counsel	Alan B. Stover, AIA	7391	Legislative Minuteman Program	Elizabeth Chalmers	7385
Government Affairs, National	Arnold J. Prima Jr., AIA	7374	Liability Insurance	Sherry Currens	7386
Government Affairs, State and Local	Elizabeth Chalmers	7385	Liability Legislation	William Hooper, AIA	7457
Government Alert for Components	Elizabeth Chalmers	7385	Library	Arnold J. Prima Jr., AIA	7374
Graphic Standards, Architectural Orders/Sales	William Miner, AIA	7302	Liens	Dale Ellickson, AIA	7440
Grassroots	Kathie Davis	7474	Life Cycle Cost Analysis	William Hooper, AIA	7457
Handbook of Professional Practice, Revisions, etc.	Bette Callet	7376	Life Insurance	William G. Wolverton, Hon. AIA	7322
Orders/Sales	Douglas DuCharme	7309	Local Government Affairs	Elizabeth Chalmers	7385
Headquarters/AIA Building	Terry L. Peck	7485	Long Span Construction	Brian Cook	7476
Health, Architecture for	Professional Interest Programs	7364	Panel		
Historic Preservation Programs	Professional Interest Programs	7364	Mailing Lists	Kathie Davis	7474
Honor Awards and Special Awards Program	Maria Murray, Hon. AIA	7390	Mailroom	Andrew Baine	7339
Honorary Fellows	Maureen Marx, Hon. AIA	7392	Media Relations		
Honorary Members	Maria Murray, Hon. AIA	7390	National	Ray Rhinehart	7463
Hospitalization Insurance	William G. Wolverton, Hon. AIA	7322	Local	Joy Brandon	7464
HOTLINE	Priscilla Bisch	7554	Meetings (at headquarters)	Shelly Getchell	7397
Housing Programs	Professional Interest Programs	7364	Membership Application	Maureen Marx, Hon. AIA	7392
			Membership Directory	Terry L. Peck	7485
			Orders		
			Membership Recruiting	Bette Callet	7376
			Membership Retention	James A. Schuping	7502
			Memo	Peter McCall	7465

continued on page 56



**Don't design an
open office with
a closed floor.**

When you design an open office, you're providing the ability to adapt quickly and easily to changing needs. It can't be done with furniture and landscape screens alone.

Support systems must adapt as readily as office personnel. That's what the open office is all about. And that's one reason successful open offices are based on Donn access floors.

Electrical and mechanical services can be changed as quickly and easily as the furniture with no unneeded outlets or holes left behind. Donn access floors let your design keep pace with new developments in electronics, communications and office technologies.

Rethink the open office concept. From top to bottom. Then ask your Donn representative for full details.

Donn makes access floors. Donn makes wall systems. Donn makes ceiling systems. But most of all, Donn makes sense.



DONN CORPORATION

1000 Crocker Road
Westlake, Ohio 44145
(216) 871-1000

Utah State Employees Credit Union
Architect: Joseph Young
Floor Contractor: Lauren Burt, Inc.

Circle 25 on information card

Contacts from page 54

Subject	Staff	Telephone	Subject	Staff	Telephone
Metric Conversion	Dale Ellickson, AIA	7440	Public Relations Dept.	Muriel Campaglia	7459
Metric Council	Dale Ellickson, AIA	7440	Publications Distribution	Terry L. Peck	7485
Mini-Grassroots	Bette Callet	7376	Publications Marketing	David Godfrey	7450
Minimum Property Standards	Henry J. Lawrence	7427	Publications Marketing/Sales	Kathie Davis	7474
Minority Data Bank	Beverly Sanchez	7434	Purchasing Department	Marjorie Ballengee	7324
Minority/Disadvantaged Scholarships	Yina A. Moore	7349	Quality Urban Environment Study Team (QUEST)	John Gaillard	7363
Minority Survey	Beverly Sanchez	7434	Regional Development	John Gaillard	7363
Minuteman Program	Sherry Currens	7386	Regional/Urban Design Assistance Teams (R/UDAT)	John Gaillard	7363
Model Building Codes	Henry J. Lawrence	7427	Registration		
National AIA Committees	James A. Schuping	7502	NCARB		659-3996
National Architectural Accrediting Board	John Wilson-Jeronimo	783-2007	State Laws	Elizabeth Chalmers	7385
National Component Seminars	James E. Ellison, AIA	7347	Registration Law	Elizabeth Chalmers	7385
National Conference of States on Building Codes and Standards	Cameron Tucker, AIA	7354	Advisory Task Force		
National Council of Architectural Registration Boards		7456	Rental Car Program	Marjorie Ballengee	7324
National Institute of Building Sciences			Research Corporation		7500
National Legislation	Samuel T. Balen, FAIA	783-6500	President	Charles R. Ince Jr.	7508
National Organization for Minority Architects	James E. Ellison, AIA	7347	Research Fellowships	Yina A. Moore	7349
News Releases			Resolutions, Convention	James A. Schuping	7502
Nominations for National Institute Office	Henry J. Lawrence	7427	Retirement Plan	William G. Wolverton, Hon. AIA	7322
Occupational Safety and Health Act (OSHA)	Government Affairs Department	7374	Rules of the Board	James A. Schuping	7502
Octagon House	Beverly Sanchez	7434	Scholarship Programs	Yina A. Moore	7349
Partnerships			Schools of Architecture	Richard McCommons (ACSA)	785-2324
Pension Programs	Public Relations Dept.	7460	Seal of the Institute	James A. Schuping	7502
Personnel Office	James A. Schuping	7502	Secretary, Assistant	James A. Schuping	7502
Policy Statements			Seismic Codes and Standards	Henry J. Lawrence	7427
Political Action Committee	Henry J. Lawrence	7427	Social Events	Shelly Getchell	7397
Practice Department			Solar Energy	John R. Hoke Jr., AIA	7458
Practice Management	Jeanne Butler Hodges	638-3105	Speakers Bureau	Bette Callet	7377
Preservation Programs	Dale Ellickson, AIA	7440	Specialty Contractors	Dale Erickson, AIA	7440
Press Relations	William G. Wolverton, Hon. AIA	7332	Standard Documents		
National			Interpretations	Dale Ellickson, AIA	7440
Local	Sheila Neary	7324	Orders/Sales	Terry L. Peck	7485
Procurement—Federal Agency Procedures	James A. Schuping	7502	Standard Forms 254-255	Frank Musica	7382
Production Systems for Architects and Engineers, Inc. (PSAE)	Stanley Kolbe	7379	State and Local Government Documents	Elizabeth Chalmers	7385
Professional Development	Elizabeth Chalmers	7385	State Government Affairs	Elizabeth Chalmers	7385
Professional Interest Committees	Allan B. Stover, AIA	7391	State Government Affairs Committee	Elizabeth Chalmers	7385
Corresponding Membership	Robert Packard, AIA	7454	State Legislative Information	Elizabeth Chalmers	7385
Professional Liability Insurance	William Hooper, AIA	7457	State Registration Laws	Elizabeth Chalmers	7385
Program and Management Services			Student Affairs	William Plimpton	7472
Programming, Architectural	James A. Scheeler, FAIA	7315	Student Competitions	William Plimpton	7472
Public Education	William Hooper, AIA	7457	Subcontractor Liaison	Dale Ellickson, AIA	7440
Public Policy			Sureties	Dale Ellickson, AIA	7440
	Alan R. Sandler	7573	Switchboard	Hilda Gasch	7300
	Mary Jo Malone	7556	Technical Training Schools Program	Yina A. Moore	7349
			Training Laboratories, Architectural	Suzon Loomis	7355
			Treasurer, Assistant	William A. Wolverton	7322
			Uniform Construction Index	William Miner, AIA	7307
			Urban Design	John Gaillard	7363
			Urban Planning Programs	John Gaillard	7363
			Regional/Urban Design Assistance Teams	John Gaillard	7363
			Women in Architecture	Beverly Sanchez	7434
			Women's Architectural League	Bette Callet	7377

WE WENT ABOVE THE ARCTIC CIRCLE TO PROVE THE EFFECTIVENESS OF A NEW INSULATED SECTIONAL STEEL DOOR.



Introducing THERMACORE. The world's only insulated sectional steel door with a patented thermal break.

Tested in the frigid environment of a Swedish winter, this revolutionary new industrial sectional steel door has achieved amazing success.

Now at Insoport Industries in Williamsport, PA, THERMACORE

industrial doors are rolling off our production lines ready to prove how they can save you energy and dollars in your location.

THERMACORE is a total system of tight seals and thermal breaks designed to prevent heat transfer and eliminate air and water infiltration.

To find out why nobody can match our U-values, our standard

widths, or our patented thermal break, write: Insoport Industries, Inc., 3200 Reach Road, P.O. Box 3033, Williamsport, PA 17701.

Or call our toll free number: 1-800-233-8992.

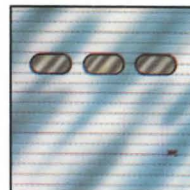

Circle 28 on information card

THERMACORE

THERE'S NO OTHER DOOR LIKE IT.

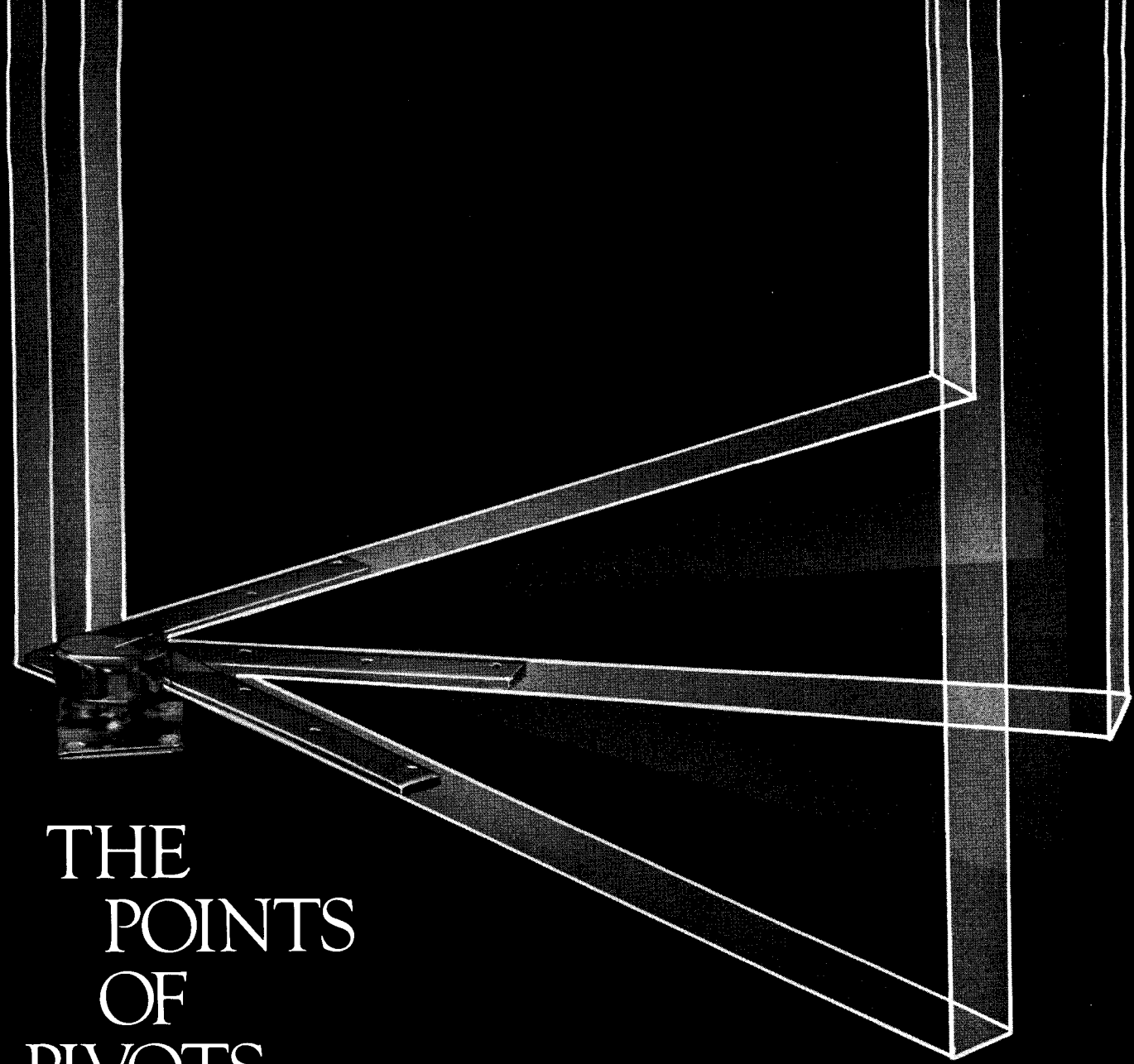

THE POINTS OF PIVOTS

Better Alternatives In Every Respect.

Rixson door pivots; the most complete line, and the most highly regarded, for good reasons.

- Life Cycle Economy – Simply, a better way to hang any swing door. Provides better anchorage than any hinge, better distributes door weight, protects door and frame, much better. Eliminates maintenance caused by door drag and binding.
- Control Capability – Assures smooth, reliable door operation, under the most demanding conditions, year after year after year.
- Architectural Acceptance – Looks better, and stays that way. Looks expensive, but surprisingly still costs less than either anchor hinges or a standard pair and a half of exterior butts. Available for all normal or extra-heavy swing doors, including security installations.

No one offers a better, more economical method of door hanging than Rixson pivots.*

*Request: "To Close A Door," a comprehensive text on various door control methods.

RIXSON-FIREMARK

9100 West Belmont Avenue
Franklin Park, Illinois 60131
and Rexdale, Ontario—
312/671-5670

A DIVISION OF
CONRAC
CORPORATION

Circle 29 on information card

AIA's Glossary of Acronyms and Abbreviations

A

AACJC
American Association of Community and Junior Colleges

AAES
American Association of Engineering Societies

AAHP
American Association for Hospital Planners

AAL
Association of Architectural Librarians

AASA
American Association of School Administrators

ABA
American Bar Association

ACA
American Correctional Association

ACEC
American Consulting Engineers Council

ACHP
Advisory Council on Historic Preservation

ACSA
Association of Collegiate Schools of Architecture

AEE
Association of Energy Engineers

AEI
Alternative Energy Institute

AERO
Alternative Energy Resource Organization

AGC
Associated General Contractors of America

AGS
Architectural Graphics Standards

AHA
American Hospital Association

AHCA
American Health Care Association

AIA
American Institute of Architects

AIA/RC
American Institute of Architects/Research Corporation

AIC
American Institute of Constructors

AICP
American Institute of Certified Planners

ALDA
American Land Development Association

ANMC
American National Metric Council

ANSI
American National Standards Institute

APA
American Planning Association

APHA
American Public Health Association

APT
Association of Preservation Technology

ARTBA
American Road and Transportation Builders Association

ASA
Acoustical Society of America

ASA
Architectural Secretaries Association

ASC/AIA
Association of Student Chapters/AIA

ASCE
American Society of Civil Engineers

ASCP
American Society of Consulting Planners

ASE
Alliance to Save Energy

ASEA
American Society of Engineers and Architects

ASHRAE
American Society of Heating, Refrigeration and Air-Conditioning Engineers

ASID
American Society of Interior Designers

ASLA
American Society of Landscape Architects

ASME
American Society of Mechanical Engineers

AUA
Association of University Architects

AUA
American Underground Space Association

B

BCMC
Board of Coordination of Model Codes

BCTC
Building and Construction Trades Council, AFL-CIO

BEPS
Building Energy Performance Standards

BLM
Bureau of Land Management, Department of Interior

BOCA
Building Officials and Code Administrators International

BOMA
Building Owners and Managers Association International

BOMI

Building Owners and Managers
Institute

BOR

Bureau of Outdoor Recreation,
Department of Interior

BRAB

Building Research Advisory Board,
National Academy of Sciences

C**CAA**

Commonwealth Association of
Architects

CABO

Council of American Building
Officials

CAC

Construction Action Council

CACE

Council of Architectural
Component Executives

CBT/NBS

Center for Building Technology,
National Bureau of Standards

CDC

Community Design Center

CEC

Consulting Engineers Council

CEFP

Council of Educational
Facility Planners

CEQ

Council on Environmental Quality

CEU

Continuing Education Unit

CFR/NBS

Center for Fire Research,
National Bureau of Standards

CIAM

Congres Internationaux d' Architecture

CIMA

Construction Industry
Manufacturers Association

COPAR

Cooperative Presentation of
Architectural Records

CPMC

Construction Products
Manufacturers Council

CPSC

Consumer Products Safety
Commission

CRC

Construction Research Council

CSI

Construction Specifications Institute

D**DOC**

Department of Commerce

DOD

Department of Defense

DOE

Department of Energy

DOT

Department of Transportation

E**EBI**

Energy Bureau, Inc.

ED

Department of Education

EDRA

Environmental Design Research
Association

EEOC

Equal Employment Opportunity
Commission

EERI

Earthquake Engineering Research
Institute

EFL

Educational Facilities
Laboratories Inc.

EGCA

Engineering and General
Contractors Association

EPA

Environmental Protection Agency

ERDAC

Energy Research and Development
Advisory Council

F**FAA**

Federal Aviation Administration,
Department of Transportation

FAIA

Fellow of the American Institute
of Architects

FCARM

Federacion de Colegios de Arquitectos
de la Republica Mexicana

FCC/BRAB

Federal Construction Council,
Building Research Advisory Board

FHA

Federal Housing Administration,
Department of Housing and
Urban Development

FHwA

Federal Highway Administration,
Department of Transportation

FIA

Federal Insurance Administration,
Department of Housing and
Urban Development

FmHA

Farmers Home Administration,
Department of Agriculture

FPAA

Federacion Panamericana de
Asociaciones de Arquitectos, Pan
American Federation of
Architects Associations

FRA

Federal Railroad Administration,
Department of Transportation

G**GSA**

General Services Administration

H**HABS**

Historic American Buildings Survey

HHS

Department of Health and
Human Services

Hon. AIA

Honorary Member of the American
Institute of Architects

Hon. FAIA

Honorary Fellow of the American
Institute of Architects

HUD

Department of Housing and
Urban Development

I**IAH**

International Association for Housing

IALD

International Association of
Lighting Designers

ICAM

International Confederation of
Architectural Museums

ICBO

International Conference of
Building Officials

ICED

Interprofessional Council on
Environmental Design

IDSA

Industrial Designers Society of
America

IES

Illuminating Engineering Society

IFRAA

Interfaith Forum on Religion,
Art and Architecture

IIID

International Institute of Interior
Design

IUD

Institute for Urban Design

continued on page 62

An elevator should do more than go up and down.

These days it's not enough to just get people where they want to go. Worker productivity, energy consumption, and tenant satisfaction are all affected by the elevator service in your buildings.

Yet a surprising number of architects still design without a second thought to elevator and escalator specs. Pity. They're overlooking options that can make a big difference in their building's utility for years to come.

Savvy architects and planners look to Schindler Haughton to speed

passenger service and reduce operating expenses. With sophisticated solid state equipment and the right choice of geared, gearless and hydraulic equipment for the job to be done.

Don't specify elevator and escalator equipment out of habit. Talk with your Schindler Haughton representative. He has a better way to get you up and down.

We're #2 in the world and going one better.



Schindler Haughton

ELEVATOR CORPORATION
Toledo, Ohio 43609



Circle 30 on information card

Acronyms from page 60

M

MCSC
Model Codes Standardizations Council

N

NAAB
National Architectural Accrediting Board

NACO
National Association of Counties

NAD
National Academy of Design

NAHB
National Association of Home Builders

NAHB/RF
National Association of Home Builders/Research Foundation

NAHRO
National Association of Housing and Redevelopment Officials

NAR
National Association of Realtors

NAVFAC
Naval Facilities Engineering Command, Department of Defense

NAWC
National Association of Women in Construction

NBS
National Bureau of Standards

NCA
National Constructors Association

NCARB
National Council of Architectural Registration Boards

NCBFE
National Center for a Barrier-Free Environment

NCIC
National Construction Industry Council

NCSBCS
National Conference of States on Building Codes and Standards

NEA
National Education Association

NEA
National Endowment for the Arts

NEAC
National Energy Advisory Council

NFPA
National Fire Protection Association

NFPCA
National Fire Prevention and Control Administration

NHRA
National Housing Rehabilitation Association

NIAE

National Institute for Architectural Education

NIBS
National Institute of Building Sciences

NOMA
National Organization of Minority Architects

NPS
National Park Service, Interior Department

NRPA
National Recreation and Park Association

NSBA
National School Board Association

NSC
National Safety Council

NSPE
National Society of Professional Engineers

NTHP
National Trust for Historic Preservation

NTIS
National Technical Information Service

O

OMBE
Office of Minority Business Enterprise

OPLR
Office for Professional Liability Research, Victor O. Schinnerer & Co.

P

PBS
Public Buildings Service, General Services Administration

PC
Producers' Council, Inc.

PSAE
Production Systems for Architects and Engineers

PSMA
Professional Services Management Association

PSPA
Passive Solar Products Association

R

RAIA
Royal Australian Institute of Architects

RAIC
Royal Architectural Institute of Canada

continued on page 66

TOWER

CONTRACT VINYL WALL COVERING

DISTRIBUTOR DIRECTORY

WALLCO

6700 N.W. 77th Court, Miami, Florida 33166
(305) 592-8000
Broward Line: 524-4352 Fla. Wats: 1-800-432-9516
Cable—WALCOINT Telex—803559

5329 West Crenshaw Street, Tampa, Florida 33614
(813) 885-2767
Fla. Wats: 1-800-282-7715

3287 Marjan Drive, Atlanta, Georgia 30340
(404) 455-6100
Ga. Wats: 1-800-282-7203

N.C., S.C., Ala., Tenn., La., Ark., Miss., Fla.
Wats: 1-800-241-7361

803 Pressley Road, Suite 108, Charlotte, North Carolina 28210 (704) 523-4167
N.C. Wats: 1-800-432-6258

S.C., VA., Wash D.C., M'land Wats: 1-800-438-2986
(809) 753-7474

186 Juan P. Duarte, Hato Rey, Puerto Rico 00925
(809) 753-7474

5800 Jefferson Hwy., Brookhollow Center, New Orleans, LA. 70123
(504) 733-3318
La. Wats: 1-800-452-8833
Miss., Ark. Ala., Wats: 1-800-535-8855

WALLCO WEST

4704 North 7th Avenue, Phoenix, Arizona 85013
(602) 274-3529 or 274-9112

4870 Nome Street, Montbello Industrial Park, Denver, Colorado 80239
(303) 373-5060

FRAZEE'S CREATIVE WALLCOVERINGS

6625 Miramar Rd., San Diego, CA 92122
(714) 276-9500

16301 CARMENITA RD. • CERRITOS, CA 90701 • (213) 926-9555

3249 N.W. 29TH AVE. • PORTLAND, OR 97210 • (503) 226-6793

Telephone: CALIF (800) 352-3889
OREGON (503) 226-6793
WASHINGTON (206) 643-0920
NEVADA (800) 421-3839
HAWAII (213) 926-9555
ALASKA (503) 226-6793

ISGO CORP.

2121 W. 21st Street
Chicago, Illinois 60608
Phone (area 312) 376-2121

1237 Conveyor Lane
Dallas, Texas 75247
Phone (area 214) 634-1313

1334 Atlantic Street
North Kansas City, Missouri 64116
Phone (area 816) 421-5060

5809 Chimney Rock
Houston, Texas 77081
Phone (area 713) 666-3232

WASHINGTON WALLCOVERINGS

5015 New Utrecht Ave.
Brooklyn, N.Y. 11219
Tel. (212) 633-8800

BREWSTER WALLCOVERING CO

288 A Street
Boston, Mass. 00210
Tel. (617) 542-9306 Telex 94-1792

THE BLONDER COMPANIES

3950 Prospect Ave.
Cleveland, Oh. 41115
(216) 431-3560

237 No. 4th St.
Columbus, Oh. 43215
(614) 221-4461

5133 E. 65th St.
Indianapolis, Ind. 46270
(317) 257-1321

21072-21076 Bridge St.
Southfield, Mich. 48075
(313) 358-4730

606 Parkway View Drive
Pittsburgh, Pa. 15205
(412) 787-7550

IN CANADA

General Paint & Wallcoverings
950 Raymur Ave., Vancouver, B.C.

Canada Wallcoverings
3275 Yonge St., Toronto, Ont.

Metro Wallcoverings
66 Orfus Rd., Toronto, Ont.

Novax Wallcoverings
740 Trans Canada, Longueuil, Que.

Reed Wallcoverings
1995 Clark Blvd.
Bramalea, Ont.

Matchless Paints
Sugar Loaf Rd.
St. John's, Newfoundland

TOWER CONTRACT VINYL WALL COVERING

A Collection of textures in deep dimension



QUALITY meets **QUALITY** — when **TOWER** contract vinyl wall covering is specified and used in new construction as well as renovated buildings. While **TOWER** contract can be found in distinctive buildings from coast to coast, **IT IS NOT USED FOR ITS TEXTURE AND WARMTH ALONE.** Our clients have come to know that the quality of **TOWER** is more than skin deep.

TOWER contract vinyl wall covering is manufactured by a calendaring process that provides an intimate bond between the vinyl covering and the fabric backing without adhesives, thus providing superior, outstanding resistance to impact and abrasion over and beyond the requirements of federal specification CCC-W-408A. The **TOWER** collection features distinctive textures in deep dimension simulating fabrics, wood, grass, masonry, leather, etc. There are 40 patterns with over 400 contemporary color selections. Colors of your own choosing and emboss effects are available.

Ensure that the catalogue is in your stacks and specifications in your file. Avoid performance risks. Contact our distributor nearest to your location for samples and assistance.



CANADIAN GENERAL-TOWER LIMITED
(OAKVILLE DIVISION)

Circle 31 on information card

WHY ALUCOBOND® MATERIAL IS THE LEVELHEADED CHOICE



Paradoxical as it may seem, one of the flattest building materials on the market is also your best choice for sleek, flowing curves.

Made of two thin sheets of aluminum with a thermoplastic core, Consolidated Aluminum's ALUCOBOND material virtually eliminates oil-canning problems.

Yet it is so easy to form that it can sweep around corners and columns in sinuously graceful lines.

When he designed the Avant Garde Optics building in Port Washington, New York, architect Michael Harris Spector took advantage of both these features—with stunning results.



FOR MIND-BENDING BUILDINGS.

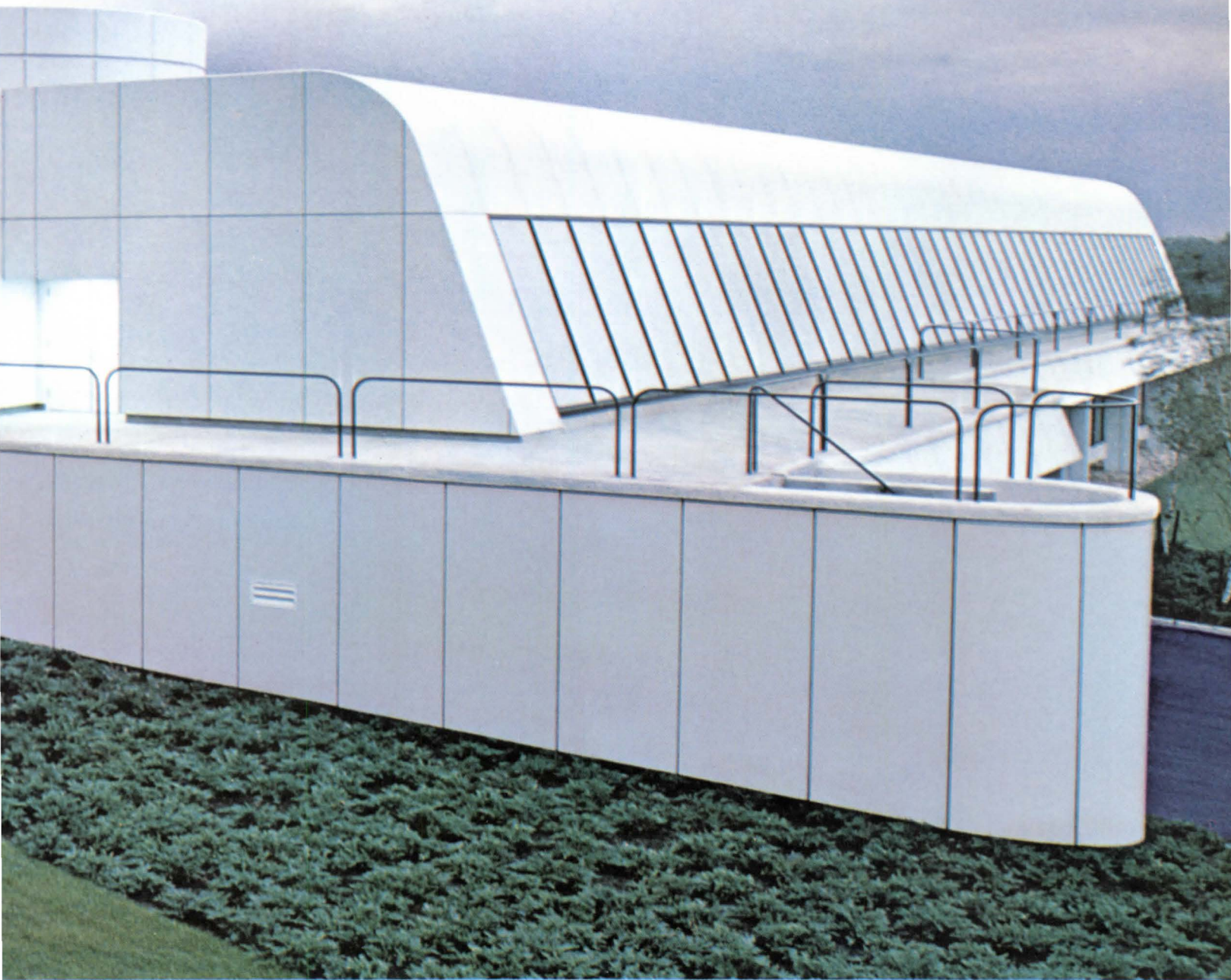

But ALUCOBOND material is more than just a pretty face. Its four anodized finishes and six coil-coated, silicon-modified polyester colors resist weather and corrosion. It comes in panel sizes

Michael Harris Spector, AIA, of Michael Harris Spector & Partners, Architects, chose ALUCOBOND material for its 'pure, honest lines,' which reflect Avant Garde's creative philosophy and high-tech, high-fashion product.

up to 5' x 28' and thicknesses of .118", .157", and .236" (3, 4, and 6mm). And it adapts to a variety of fastening systems, so installation is economical and relatively simple.

To find out more, call one of the distributors on the next page. Or contact our Marketing Manager, Carla Lane, at (314) 851-2346.

Either way you use it, you'll find the going smoother with ALUCOBOND material.

Turn page for distributor listing.



Circle 32 on information card

ALUCOBOND® MATERIAL IS AVAILABLE NATIONWIDE FROM THESE DISTRIBUTORS:

NORTHEAST

Almac Associates, Inc.
Latham, NY 12110
518-785-3226

Fred Boschan Co.
Philadelphia, PA 19127
215-483-8000

Curtainwalls Unlimited, Inc.
New York, NY 10016
212-684-0900

Custom Walls & Windows
Kensington, MD 20795
301-949-6550

EPI Architectural Systems
Pittsburgh, PA 15221
412-242-6900

The Fox Steel Company
Orange, CT 06477
203-799-2356

Frank N. Henry, Inc.
Wilkes-Barre, PA 18703
717-824-4611

Kenneth J. Herman, Inc.
Amityville, NY 11701
516-691-8669

B.R. Johnson, Inc.
Syracuse, NY 13057
315-437-1070

Metal Construction Ser-
vices, Inc.
Baltimore, MD 21218
301-889-4020

A.O. Stilwell Co., Inc.
Buffalo, NY 14224
716-828-1415

SOUTHEAST

Craeto Glass & Mirror Co., Inc.
New Orleans, LA 70179
504-821-2620

Delph-Context, Inc.
Charlotte, NC 28234
704-376-3671

Atlanta, GA 30341
404-451-7436

Demarest Company, Inc.
Oneco, FL 33558
813-758-3811

Fletcher and Associates
Birmingham, AL 35203
205-328-0525

Montgomery, AL 36104
205-263-7581

Huntsville, AL 35803
205-883-9830

John W. McDougall Co.
Nashville, TN 37209
615-321-3900

Penco, Inc.
Louisville, KY 40203
502-584-1166

W.H. Stovall & Co.
Ashland, VA 23005
804-798-1415

Wm. S. Trimble Co.
Knoxville, TN 37901
615-573-1911

MIDWEST

Black Hills Glass &
Mirror Co.
Rapid City, SD 57701
605-343-3090

Carter Glass Company, Inc.
Kansas City, MO 64101
816-471-8288

Casewin, Inc.
Minneapolis, MN 55416
612-545-1635

Condit Construction Products
Dayton, OH 45409
513-298-9922

Columbus, OH 43228
614-274-2283

Cincinnati, OH 45242
513-489-6444

Johnson Construction
Specialties, Inc.
Houston, TX 77001
713-224-8830

Jones & Brown Company
Addison, IL 60101
312-543-0300

Karl Block Co.
St. Louis, MO 63144
314-647-8044

Ohio Building Products
Willoughby, OH 44094
216-953-1100

J.M. Power Company
Trenton, MI 48183
313-479-2200

R.L. Shaffner Associates
South Bend, IN 46614
219-291-5902

Carmel, IN 46032
317-844-7599

Swanson-Gentlemen, Inc.
Des Moines, IA 50309
515-244-0186

Swanson-Gentlemen-Hart, Inc.
Omaha, NE 68154
402-493-9393

Tejas Architectural
Products, Inc.
Dallas, TX 75220
214-358-4533

The Womble Co.
Oklahoma City, OK 73152
405-525-7417

WEST

Associated Specialties Co.
Salt Lake City, UT 84106
801-487-8501

Fargo Glass & Paint
Fargo, ND 58102
701-235-4441

Vantine's Glass
Bismarck, ND 58502
701-255-0882

Fargo Glass Minot
Minot, ND 58701
701-852-3576

Fentron Highway
Products, Inc.
Seattle, WA 98107
206-789-2800

Portland Wire & Iron
Portland, OR 97202
503-234-9731

RPS Architectural Systems
Sun Valley, CA 91352
213-875-1703

Tri-Jack Mfg. Co.
Billings, MT 59104
406-245-4116

Viking Glass, Inc.
Sioux Falls, SD 57101
605-336-7044

ALASKA

Arctic Glazing Contractors
Anchorage, AK 99502
907-274-5551

ALUCOBOND is the registered trademark of Consolidated Aluminum Corporation for its aluminum composite material.

Technical information with reference to ALUCOBOND® material test results can be obtained by writing to Consolidated Aluminum, Attention: Carla Lane. Always consult local building codes before use.

System design and fabrication for the building on the preceding page by Kenneth S. Herman, Inc. of Amityville, New York, ALUCOBOND® material supplied by Adam Metal Supply of Eliza-

beth, New Jersey. Construction management by Kulka Construction Management Corporation, Smithtown, New York.

See our SWEETS Catalog for additional product information.



11960 Westline Industrial Drive
St. Louis, Missouri 63141

Circle 32 on information card

Acronyms from page 62

RANN
Research Applied to National Needs,
National Science Foundation

RCSHSB
Red Cedar Shingle and
Handsplint Shake Bureau

RIBA
Royal Institute of British Architects

R/UDAT
Regional/Urban Design Assistance
Team

S

SAH
Society of Architectural Historians

SARA
Society of American Registered
Architects

SBC
Standard Building Code

SBCC
Southern Building Code Congress

SCUP
Society for College and
University Planning

SEA
Solar Energy Association

SEI
Solar Energy Institute of America

SERI
Solar Energy Research Institute

SHAF
Solar Homes Association and
Foundation

SMPS
Society of Marketing
Professional Services

SSRC
Structural Stability Research Council

U

UBC
Uniform Building Code

UCI
Uniform Construction Index

UIA
Union Internationale des Architectes

UIFA
Union Internationale des Femmes
Architectes

UL
Underwriters Laboratories Inc.

ULI
Urban Land Institute

W

WEF
Wind Energy Foundation

LITE-PAK

From Rambusch.

A mini quartz lighting fixture engineered for maximum performance.

Attractive, innovative, compact. Measuring just over 4" x 6½". With a range of applications as a wall wash, as indirect and accent lighting.

Lite Pak projects a powerful grazing light across a surface in a uniform arc. Its 150W tungsten-halogen lamp and electro-brightened segmented reflector provide high utilization; twice as much as many conventional wall washers.

Lite Pak reveals a full color spectrum to accurately light works of art. Its hinged access cover has a special UV filter to block ultra violet light.

Lite Pak on a variable yoke is available with 4 mounting devices. Made of die cast and extruded aluminum, it bears the UL label. Used singly or in multiples, Lite Pak solves a variety of lighting problems.

For information: Rambusch, 40 West 13th St., NY 10011 or call (212) 675-0400.

Circle 33 on information card

Available through Rambusch 'reps' and selected showrooms.

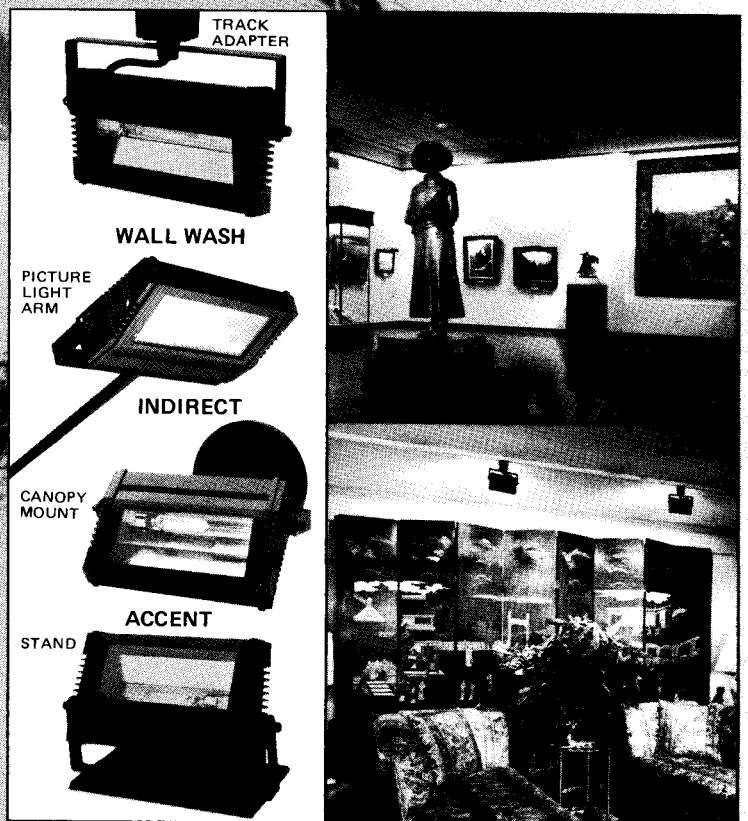

RAMBUSCH

Cheers!



Introducing Quarry Naturals.

It's new from American Olean. And we've built a new ceramic tile plant to make it for you.

Quarry Naturals™ tile has great character. It's uniquely textured. It's a warm, earthy quarry tile. It picks up color generously. And subtly.

Quarry Naturals—made in America—has a great heritage and proud name. It's incredibly durable. And so easy to maintain.

It's available now in three sizes ($3\frac{7}{8}$ " x 8", 6" x 6", 8" x 8") and four rich, earth-tone blends, with more coming. Each carton is "pre-blended." Great care is given so the blending is consistent. And we have a line of trim pieces which complete the job.

See Quarry Naturals at any of our showrooms (check the Yellow Pages). For more information,

contact your American Olean sales representative or write to: American Olean Tile Company, 2881 Cannon Avenue, Lansdale, PA 19446.



A National Gypsum Company

Circle 34 on information card

Yellow Pages' Index

Adaptive Use		Contract Information	81	Masterspec	
<i>see</i> : Historic Preservation	93	<i>see also</i> :		<i>see</i> : Specifications	105
A/E Selection	70	Construction Management	81	Meetings	97
<i>see also</i> :		Project Delivery	102	Membership	97
Architect-Client Relations	71	Contracts and Documents	82	The Octagon	97
Government Affairs—National	90	Education	85	Office Management	98
Government Affairs—		<i>see also</i> :		Periodicals	98
State and Local	90	Careers in Architecture	77	Posters	99
Affirmative Action	70	Educational Facilities	86	Practice	99
<i>see also</i> : Women in Architecture	106	Energy	86	<i>see also</i> :	
AIA	70	Environmental Design	87	Computer Applications	80
<i>see also</i> : The Octagon	97	<i>see also</i> :		Financial Management	89
Arbitration	71	Land Use	95	Office Management	98
<i>see also</i> : Contract Information	81	Urban Planning	106	Presentation Techniques	100
Architect-Client Relations	71	Environmental Education	88	Professional Development	100
<i>see also</i> : A/E Selection	70	Ethics	88	Professional Interest Programs	101
Architects	71	Exhibits	88	Programming	102
<i>see also</i> : Membership	97	Financial Management	89	<i>see also</i> : Computer Applications	80
Architecture (General)	72	<i>see also</i> :		Project Delivery	102
Archives	73	Computer Applications	80	Public Buildings	102
Arts and Recreation	73	Office Management	98	Public Relations	102
Audiovisual Materials	73	Practice	99	<i>see also</i> :	
Awards	75	Firesafety	90	Architect-Client Relations	71
Barrier-Free Architecture	76	Funding	90	Audiovisual Materials	73
Bibliographies	76	Government Affairs—National	90	Marketing	96
Building Costs	77	<i>see also</i> : A/E Selection	70	Publications Sales	104
Building Evaluation	77	Government Affairs—		Railroad Stations	104
Building Types	77	State and Local	90	Real Estate	105
Careers in Architecture	77	<i>see also</i> :		Registration	105
<i>see also</i> :		A/E Selection	70	Research	105
Education	85	Registration	105	Signs	105
Codes and Standards	77	Guidebooks	92	Solar Energy	
<i>see also</i> :		Historic Preservation	93	<i>see</i> : Energy	86
Firesafety	90	Housing	94	Specifications	105
Legal Concerns	95	Industrial Architecture	94	<i>see also</i> : Working Drawings	106
Community Centers	78	Insurance	94	Transportation	106
Community Development	78	Interiors	95	Underground	106
<i>see also</i> : Urban Planning	106	International Relations	95	Urban Planning	106
Competitions	78	Joint Ventures	95	<i>see also</i> :	
Components, AIA	78	Justice Facilities	95	Community Development	78
Computer Applications	80	Land Use	95	Environmental Design	87
<i>see also</i> :		<i>see also</i> :		Land Use	95
Financial Management	89	Environmental Design	87	Women in Architecture	106
Programming	102	Real Estate	105	<i>see also</i> : Affirmative Action	70
Construction Industry	80	Urban Planning	106	Working Drawings	106
Construction Management	81	Legal Concerns	95	<i>see also</i> :	
<i>see also</i> :		<i>see also</i> :		Presentation Techniques	100
Contract Information	81	Codes and Standards	77	Specifications	105
Project Delivery	102	Contract Information	81		
Library	96	Library	96		
<i>see also</i> : Audiovisual Materials	73	<i>see also</i> : Audiovisual Materials	73		
Marketing	96	Marketing	96		
<i>see also</i> : Public Relations	102	<i>see also</i> : Public Relations	102		

Directory of AIA Resources

Following are publications, audiovisual materials and special services offered by AIA. When two prices are given, the first is for AIA members, the second for nonmembers. AIA component publications should be ordered directly through the state or local chapter.

A/E Selection

Architect/Engineer Government Contracting: A Manual (4-M718)

In loose-leaf format, this manual (1979) contains actual forms, documents, regulations, laws, guidelines and techniques used by public officials and design practitioners in A/E contracting. Prepared by Committee on Federal Procurement of A/E Services (COFPAES). \$95.

Available through Publications Fulfillment Office (626-7332).

Architect/Engineer Selection: The American Bar Association Code for State and Local Governments

A case study (1981) containing the A/E selection provisions of the ABA code and a brief description of A/E selection. Free.

Available through Government Affairs Office (626-7375).

Architect Selection: Legislative Guidelines for Public Construction

Contains two model A/E selection bills for public construction projects and copies of existing state A/E selection laws. (Revised 1980). Free

Available through Government Affairs Office (626-7375).

Compendium: Architect Selection Laws (4-N509)

Contains laws of the 18 states that now have specific legislation regulating the selection of architects for public construction projects. Appendix contains a list of state agencies responsible for implementing these laws and the federal A/E (Brooks) procurement law. Free to members; \$5, nonmembers.

Available through Publications Fulfillment Office (626-7332).

Planning City Hall

20-page publication (1975) prepared for the International City Management Association under a grant from AIA, outlines AIA's preferred method of architect selection based on qualification in addition to other considerations relating to building construction. It is a useful tool when discussing A/E selection with state and local officials. Free.

Available through Government Affairs Office (626-7375).

Working in Government: A Profile Study of the Architect as a Public Employee (2-M712)

40-page report (1978) prepared by AIA's architects in government committee. The information presented in this report is intended to give the general public a better understanding of the various functions performed by architects in government. Developed from a survey of more than 2,000 architects in government conducted in 1976, it provides a comprehensive profile of those persons practicing as architects in the public sector. \$5/\$6.

Available through Publications Fulfillment Office (626-7332).

For further information about A/E selection, contact the following offices: federal and state government—Government Affairs Office, 626-7375; nongovernmental projects—Professional Interest Programs Office, 626-7364.

Affirmative Action

Directory of Minority and Women Owned Architectural and Engineering Firms (4-M709)

The directory (1981) prepared by AIA and the American Consulting Engineers Council (ACEC) lists both member and nonmember minority and women owned architectural and engineering firms nationwide. \$10 for AIA and ACEC members, \$15 for nonmembers.

Available through Publications Fulfillment Office (626-7332).

For further information about affirmative action, contact the Minority Resources Office, 626-7434.

AIA

AIA and Related Organizations (1-HBC3)

Chapter 3 (1972) of the Architect's Handbook of Professional Practice, this document explains AIA and its associated organizations, and outlines the roles of related professional societies. \$1.20/\$1.80.

Available through Publications Fulfillment Office (626-7332).

AIA Bylaws (6-N100)

40-page publication, updated annually by the secretary of the Institute, outlining the bylaws of AIA. Free.

Available through Publications Fulfillment Office (626-7332).

AIA Emblem for Printing

Instruction sheet regarding rules for use of AIA emblem. Two sheets of reproduc-

ible emblems in various sizes for use on letterheads, etc. Free. In limited quantities.

Available through Public Relations Department (626-7460).

AIA Ethical Guidelines (6-J400)

Explains the principles which serve as voluntary guidelines for the professional conduct of members of AIA.

Available through Office of Assistant Secretary (626-7502) or Publications Fulfillment Office (626-7332).

AIA Headquarters Slide Show

50 color slides, with script and cassette tape (1974). Past AIA President Archibald Rogers, FAIA, discusses the AIA headquarters building and the Octagon. Free loan to AIA members only.

Available through Audiovisual Department, Library (626-7495).

AIA Journal

Official magazine of AIA, published monthly except May and August, when semimonthly. Subscription price included in AIA membership dues.

For subscription information for others, contact Circulation Department, AIA Journal (626-7327).

AIA Membership Directory (4-M136)

Annual alphabetical listing of AIA members, including addresses and chapter affiliations. Appendices include honorary members and fellows, component presidents, medals and awards, affiliated and associated organizations. \$15/\$75.

Available through Publications Fulfillment Office (626-7332).

AIA Memo

Newsletter, published twice a month, sent to the entire membership. Aims to keep members abreast of Institute programs, achievements, services, etc. Free.

Available through Public Relations Department (626-7465).

AIA National Convention

Annual conference for all AIA members, where officers are elected, product information displayed, workshops and seminars presented, etc. Location and registration fee vary.

Contact Convention Office, 626-7395.

AIA Research Corporation

AIA/RC descriptive brochure.

Available through AIA/RC at AIA Headquarters (626-7500).

AIA Tote Bag (4-M419)

The American Institute of Architects in bold black letters with AIA emblem on off-white heavy-duty cotton canvas. Washing instructions included. 10x13½x4½

inches. AIA members and components only. \$6 each.

Available through Publications Fulfillment Office (626-7332).

Annual Committee Reports

AIA committees report annually to the board of directors on their activities. Free. *Available through Office of Assistant Secretary (626-7502).*

Minutes of the Board of Directors, Minutes of the Executive Committee

Published minutes of the board and executive committee meetings are distributed to component officers and chapter offices, and are available for consultation by the membership.

Available through Office of Assistant Secretary (626-7502).

No Little Plans

The history of the AIA and its services today, featuring Elmer Botsai, FAIA; Wolf Von Eckardt, Hon. AIA, and Winfield Rankin, Hon. AIA; includes material drawn from the AIA archives and library. 16mm color slide-film, 18 minutes. Free loan to AIA components and chapters.

Available through Audiovisual Department, Library (626-7495).

Organizational Directory (4-P105)

Annual directory of AIA officers and committees; component officers and executives. Shows organizational structure of Institute. Includes a list of related architectural organizations. Free to component officers and executives. \$6 to AIA members only.

Component officers and executives contact the Component Services Office, (626-7376). Members contact Publications Fulfillment Office (626-7332).

Policy Statements (6-N103)

General statements issued by the board of directors that concern architects or architecture and relationships outside AIA.

Free.

Available through the Office of Assistant Secretary (626-7502).

Publications Marketing/Sales

AIA sells documents, books, audiovisual materials, etc., to architects, components and the public. Members and components are entitled to varying discounts, depending on nature of the publications.

Contact Publications Marketing Sales Office (626-7474).

Publications Price List and Order Form (6-N702)

List of AIA books and manuals available for sale through AIA. Free.

Available through Publications Fulfillment Office (626-7332).

Report of the Board

Annual report of AIA. Free.

Available through Public Relations Department (626-7460).

Rules of the Board of Directors (6-N102)

Publication prepared by the secretary of the Institute, listing the formally adopted rules regulating conduct of AIA. Free. *Available through Office of Assistant Secretary (626-7502) or Publications Fulfillment Office (626-7332).*

Summary of the Program and Membership Services Budget

Summary of AIA's budget showing income and expense statements and program summaries. It makes the budget easier to understand. Issued annually. Free.

Available through Executive Office (626-7310).

For further information about AIA in general, contact the Public Relations Department, 626-7460.

Arbitration

AIA Adoption of the AAA Construction Industry Arbitration Rules

Four-page publication (1975) that explains the conversion, in 1966, from AIA's Standard Form of Arbitration Procedure to the Construction Industry Arbitration Rules. Free.

Available through Documents Office (626-7440).

Construction Contract Disputes: How They May Be Resolved Under the Construction Industry Arbitration Rules

Pamphlet prepared by the American Arbitration Association that answers arbitration questions. Free.

Available through Documents Office (626-7440).

Construction Industry Arbitration Rules

10-page publication (1979) of the American Arbitration Association containing arbitration rules and procedures. Free.

Available through Documents Office (626-7440).

For further information about arbitration, contact the Documents Office, 626-7440.

Architect-Client Relations

Dun's Review Reprint (4-N8360Q)

"Constructing the Cost-Effective Facility: Corporate Options in the '80s" from January 1981 issue. Article focusing on energy conscious design is an appropriate handout for corporate groups or clients.

Single copy free. \$6 per 10 copies.

Available through the Public Relations Department (626-7460) or the Publications Fulfillment Office (626-7332).

Selling Architectural Services (3-S207)

Cassette (1973) shows how the architect can conduct a practice in a professional and more prosperous manner by using effective marketing techniques. \$10/12.

Available through Publications Fulfillment Office (626-7332).

Selling Architectural Services II (3-S218)

This cassette (1975) examines the person-to-person selling process. It focuses on how to understand and work with your client's problem, achieving a mutually beneficial client-architect relationship. \$10/\$12.

Available through Publications Fulfillment Office (626-7332).

You and Your Architect (4-N802Q)

Publication (1980) by David R. Dibner, FAIA, that answers client questions about the selection and compensation of an architect. Outlines responsibilities of the architect and the client during construction. Single copy free. \$10 per 100.

Available through Public Relations Department (626-7460) or Publications Fulfillment Office (626-7332).

For further information about the role of the architect, contact the Public Relations Department, 626-7460.

Architects

The Architect as Artist

Octagon exhibition catalog containing one color and eight black and white illustrations. Seven-page checklist of 26 participating architects and titles of art work given to the AIA Foundation. \$2.50.

Available through the Octagon, 1799 New York Ave. N.W., Washington, D.C. 20006 (638-3105).

Architects/Architecture

(1977, International Masonry Institute) 16mm color film, 36 minutes. Four American architects discuss architectural design and the opportunities and problems facing students and practitioners. Features Warren Cox, FAIA; George Hartman, FAIA; Ulrich Franzen, FAIA, and Philip Johnson, FAIA, and shows examples of their work. Rent \$15 to AIA members only.

Available through Audiovisual Department, Library (626-7495).

Ar

Biographical Information on Architects

The library will attempt to provide biographical information on individual architects, using reference sources such as the Baldwin Memorial Archive of American Architects.

Contact the Library, 626-7493.

Conversation with an Architect (4-Q118)

16mm color sound film, 28 minutes (1975). Discusses the role of the architect in today's society. Shows architects at work on a planned housing development, a school, a factory and an urban area. Free loan to AIA members and components only; \$95 for used copy in good condition.

Available through Audiovisual Department, Library (626-7495).

Conversation with an Architect

Two-page flyer describing theme and subject matter of 1975 film by same title. Free.

Available through Public Relations Department (626-7460).

Do It with an Architect

Bumper sticker, \$1 each.

Available through Association of Student Chapters/AIA at AIA Headquarters (626-7472).

First Principles

16mm color film (18 minutes) with Vincent Scully, narrator. Discussion of Louis I. Kahn's philosophy of design with examples of his masonry work in conjunction with Roman architecture. Rent \$15 to AIA members.

Available through Audiovisual Department, Library (626-7495).

Frank Lloyd Wright Crayon Drawing "Sahuaros"

Numbered edition serigraph (total edition 200); image size 12¼ x 13¼ inches, each print initialed on white border by Mrs. Frank Lloyd Wright, overall size 17½ x 18¼ inches, mailable, \$300 postpaid.

Available from Arizona Architects Foundation, Inc., 1108 W. Washington, Phoenix, Ariz. 85007.

Harold Sterner: Architect and Artist

Exhibition catalog (1978) on Harold Sterner, and the interrelationship between his art and architecture. Illustrated. \$3.

Available through the Octagon, 1799 New York Ave. N.W., Washington, D.C. 20006 (638-3105).

Mr. Wright and the Johnsons of Racine, Wis.

Reprint from AIA JOURNAL (1979) of an informal talk by Samuel C. Johnson on

Frank Lloyd Wright and comments about the Wright architecture commissioned by his father. Free.

Available through Director, Design and Environment Programs (626-7363).

S. E. Rasmussen

67 color slides (1979) with cassette tape featuring famed Danish architect and town planner S. E. Rasmussen. Rasmussen narrates the 24-minute program, which is based on his AIA medal-winning book, *Experiencing Architecture*. Free loan; AIA members only.

Available through Audiovisual Department, Library (626-7495).

The Travel Sketches of Louis I. Kahn

63-page exhibition catalog (1977) including illustrations and discussion of 91 travel sketches of Louis I. Kahn, dating from 1913 to 1959. Prepared by the Pennsylvania Academy of the Fine Arts. 31 black and white illustrations, four color plates. \$8 postpaid.

Available through the Octagon, 1799 New York Ave. N.W., Washington, D.C. 20006 (638-3105).

William Thornton: A Renaissance Man in the Federal City

48-page exhibition catalog (1976) for exhibition, held at the Octagon, on the first architect of the United States Capitol and the Octagon. Prepared by David N. Yerkes, FAIA, and Elinor Stearns; 46 black and white illustrations. \$3.75 postpaid.

Available through the Octagon, 1799 New York Ave. N.W., Washington, D.C. 20006 (638-3105).

Detailed biographical information on individual architects may be obtained through the Library, 626-7493.

Architecture (General)

Architectural Fantasies: Creative Alternatives

13-page illustrated Octagon exhibition catalog featuring fantasies by Claes Oldenburg, David Macaulay, SITE Projects and seven additional architects. \$2.50.

Available through the Octagon, 1799 New York Ave. N.W., Washington, D.C. 20006 (638-3105).

Art in Architecture (6-N828)

Pamphlet (1979) providing a brief overview of the history of art in architecture, ground rules and possible sources for funding. Free.

Available through Public Relations Department (626-7460).

Books on Architecture/Related Subjects

Alphabetical listing of over 4,000 books

used by the architectural profession and of interest to the public, giving title, author, publisher and price of books available from hundreds of publishers. Revised annually in October. Free. Send \$3 for postage and handling.

Available through St. Louis Chapter/AIA, 919 Olive St., St. Louis, Mo. 63101, (314) 621-3484.

Celebrating American Architecture: Program Package 13 (4-N825)

Slide show (1979) designed to provide general audiences with a better understanding of American design and architecture. Eighty color slides of 1979 national honor award and 25-year award winning buildings depicted. Script provides introduction and brief general description of the structures. \$18 prepaid. Available through Public Relations Department (626-7460) or Publications Fulfillment Office (626-7332).

Historic Buildings and Contemporary Structures

Two books featuring 18 historical structures and 12 contemporary buildings, complete with slides. Authored by members of the Women's Architectural League, with an architect consultant for each building, and edited by George McCue, Hon. AIA, and Robert Vickery, AIA. *Historic Buildings* features 80 slides, \$28 postpaid; *Contemporary Structures* 40 slides, \$18 postpaid. Historical outline of events, \$2 postpaid.

Available through St. Louis Chapter/AIA, 919 Olive St., St. Louis, Mo. 63101, (314) 621-3484.

How Architecture Speaks: Program Package Two (4-N808)

43 slides, guidelines, script and quiz sheets (1974) that show people how architecture "speaks" through form, color, scale, texture, materials. \$18 prepaid.

Available through Publications Fulfillment Office (626-7332) or Public Relations Department (626-7460).

The Practice of Architecture in the U.S.A.

Four-page leaflet (1977) that outlines AIA, schools of architecture, registration, practice, etc., for foreign architects and students. Free.

Available to non-U.S. residents only through Office of Assistant Secretary (626-7502).

For further information about architecture in general, contact either the Public Relations Department, 626-7460, or the Library, 626-7493.

Archives

Design Competitions Archive

AIA library competitions archive is a repository for the documentary material (excluding drawings) generated by architectural design competitions. Sponsors and/or professional advisers of recent competitions should send the archive copies of competition announcements, press releases, photographs of winning designs, publications, etc. Drawings should be donated to local libraries or archives. *Contact the Library (626-7493).*

Selections from the AIA Architectural Archives

Catalog (1977) containing highlights of the extensive AIA architectural archives. \$3.

Available through the Octagon, 1799 New York Ave. N.W., Washington, D.C. 20006 (638-3105).

"That Red Head Gal"; Fashions and Designs of Gordon Conway 1916-1936

Octagon exhibition catalog of photographs, theatrical costumes, fashion designs and movie stills from the archives of Gordon Conway. \$8.50.

Available through the Octagon, 1799 New York Ave. N.W., Washington, D.C. 20006 (638-3105).

Arts & Recreation

American Endless Weekend (2-M151)

64-page publication (1973) by C. Ray Smith, AIA, that treats recreation problems and planning in America. Prepared for the AIA committee on architecture for the arts and recreation. \$5/\$6.

Available through Publications Fulfillment Office (626-7332).

Mobile Recreation (AIA Committee on Architecture for the Arts and Recreation)

80 color slides (1979) with cassette tape depicting a mobile system for providing many types of recreational, cultural and educational activities for inner city youths. Free loan.

Available through Audiovisual Department, Library (626-7495).

For further information about arts and recreation facilities, contact the Professional Interest Programs Office, 626-7364.

Audiovisual Materials

AIA Headquarters Slide Show

50 color slides, with script and cassette tape (1974). Past AIA President Archibald Rogers, FAIA, discusses the AIA headquarters building and the Octagon. Free loan to AIA members only.

Available through Audiovisual Department, Library (626-7495).

All Weather Construction

65 color slides with tape cassette and script explaining techniques for cold weather masonry construction. Free loan to AIA members.

Available through Audiovisual Department, Library (626-7495).

Architects/Architecture

(1977, International Masonry Institute) 16mm color film, 36 minutes. Four American architects discuss architectural design and the opportunities and problems facing students and practitioners. Features Warren Cox, FAIA; George Hartman, FAIA; Ulrich Franzen, FAIA, and Philip Johnson, FAIA, and shows examples of their work. Rent \$15 to AIA members only.

Available through Audiovisual Department, Library (626-7495).

Architectural Career Awareness Package (3-M401)

80 color slides with script for use by high school counselors or architects lecturing young groups of prospective architects. Includes "Architecture Schools in North America" and assorted pamphlets. \$27/\$30.

Available through Association of Student Chapters/AIA at AIA Headquarters (626-7472) or Publications Fulfillment Office (626-7332).

Architecture and Your Life (4-Q101)

35mm, 50 frame color filmstrip, with teacher's guide. Discusses the use of architecture by man and the unprecedented responsibility of today's citizen for deciding upon the quality of this environment. \$2.

Available through Publications Fulfillment Office (626-7332).

Audiovisual Materials

Four-page annotated list (1980) of audiovisual materials available for loan and/or sale from the AIA library. Free loan.

Available through the Library (626-7493).

Bibliographies of Audiovisual Materials Available Through Sources Other Than AIA

The audiovisual librarian will supply on request bibliographies of A/V materials

on various architecture and planning topics. Materials listed have not been screened.

Contact Audiovisual Department, Library (626-7493).

Building Evaluation (3-S212)

Cassette and booklet (1974) explain how to evaluate existing environments for better programming in relation to human needs. \$10/\$12.

Available through Publications Fulfillment Office (626-7332).

A Child Went Forth

16mm color film (28 minutes) focusing on the debilitating effects of inner-city schools on children, and providing a contrast with new innovative projects for school architecture. Free loan.

Available through Audiovisual Department, Library (626-7495).

Conversation with an Architect

16mm color sound film, 28 minutes (1975). Discusses the role of the architect in today's society. Shows architects at work on a planned housing development, a school, a factory and an urban area. Free loan to AIA members and components only; \$95 for used copy in good condition.

Available through Audiovisual Department, Library (626-7495).

Designing Your Brochure as an Aid in Marketing Your Services (3-S224)

This one-hour cassette (1976) tells you how to gear your brochure to your desired market by making it convey your firm's personality, your ability to take care of the client, your problem-solving ability, the range of your services, etc. The contents of an "ideal" brochure are outlined. \$10/\$12.

Available through Publications Fulfillment Office (626-7332).

Designscape

160 color slides with reel-to-reel synchronized tape (1975). A visually delightful view of many of the old and new "designs" we see all around us. Free loan to AIA members only.

Available through Audiovisual Department, Library (626-7495).

Downtowns for People

16mm color film, 26 minutes (1972) showing examples of European and American downtown areas from the

pedestrian's viewpoint. Free loan to AIA members only; no sale.

Available through Audiovisual Department, Library (626-7495).

Environments for People: Program Package 5 (4-N812)

80 slides, introduction, script and suggestions for use (1976). Explains how architects provide for basic human needs (shelter, privacy, personalization, socializing mobility, communication) in their design of the human environment. \$20 prepaid.

Available through Publications Fulfillment Office (626-7332).

Film Loans

The audiovisual librarian has a collection of films on architecture and planning subjects, most of which are available for free loan to AIA members and the general public. The only charge is return postage via UPS or insured mail.

Contact Audiovisual Department, Library (626-7495).

First Principles

16mm color film (18 minutes) with Vincent Scully, narrator. Discussion of Louis I. Kahn's philosophy of design with examples of his masonry work in conjunction with Roman architecture. Rent \$15 to AIA members.

Available through Audiovisual Department, Library (626-7495).

How Architecture Speaks: Program Package 2 (4-N808)

43 slides, guidelines, script and quiz sheets (1974) that show people how architecture "speaks" through form, color, scale, texture, materials. Quiz tests people's reactions to structures. \$18 prepaid.

Available through Publications Fulfillment Office (626-7332) or Public Relations Department (626-7460).

Intern-Architect Development Program (IDP)

Cassette and slides of an in-depth review of IDP concepts, participation and operation, including the AIA supplementary education program and advisory system. 20 minutes. Free loan to AIA members/components.

Available through Professional Development Office (626-7354).

Lafayette R/UDAT

16mm color film, 25 minutes (1978), documents the AIA R/UDAT visit to

Lafayette, La. Free loan to AIA members. *Available through Audiovisual Department, Library (626-7495).*

Los Angeles: 20th Century American City (Environmental Communications)

87 color slides with booklet. Explores important aspects of new trends and problems in contemporary urban development: urban sprawl, low-density ghetto, freeway systems, leisure facilities, land use patterns. Rent \$15 to AIA members only.

Available through Audiovisual Department, Library (626-7495).

The Management of Time (3-S216)

Cassette explaining how to accomplish more in less time. A guide to organizing and using time efficiently and effectively. 45 minutes. \$10/\$12.

Available through Publications Fulfillment Office (626-7332).

Mobile Recreation (AIA Committee on Architecture for the Arts and Recreation)

80 color slides (1979) with cassette tape depicting a mobile system for providing many types of recreational, cultural and educational activities for inner city youths. Free loan.

Available through Audiovisual Department, Library (626-7495).

No Little Plans

16 mm color slide-film, 18 minutes. The history of the AIA and its services today, featuring Elmer Botsai, FAIA; Wolf von Eckardt, Hon. AIA, and Winfield Rankin, Hon. AIA; includes material drawn from the AIA archives and library. Free loan to AIA components and chapters.

Available through Audiovisual Department, Library (626-7495).

Octagon Slide Set

Five color slides of the Octagon. \$2.50 postpaid.

Available from the Octagon, 1799 New York Ave. N.W., Washington, D.C. 20006 (638-3105).

Reach for the Sun: Program Package 13 (4-N833)

Set of 80 slides and script (1981) illustrating passive solar design principles and their applications through diagrams and representational building samples. Regional and climatic considerations are evident in the examples used. Intended for a nontechnical audience. \$22 prepaid. *Available through Public Relations Department (626-7460) or Publications Fulfillment Office (626-7332).*

S. E. Rasmussen

67 color slides (1979) with cassette tape featuring famed Danish architect and town planner S. E. Rasmussen. Rasmus-

sen narrates the 24-minute program, which is based on his AIA medal-winning book, *Experiencing Architecture*. Free loan to AIA members only.

Available through Audiovisual Department, Library (626-7495).

Scope of Services of Interior Architecture (AIA Committee on Interior Architecture)

200 color slides (1980) with script describing the array of services architects provide in interior design, relating these services to AIA Document B171, "Standard Form of Agreement for Interior Design Services." Show designed for two projectors and two screens, but can be shown in a single projector and screen. Free loan to AIA members only.

Available through Audiovisual Department, Library (626-7495).

Selling Architectural Services (3-S207)

Cassette (1973) shows how the architect can conduct a practice in a professional and more prosperous manner by using effective marketing techniques. \$10/\$12.

Available through Publications Fulfillment Office (626-7332).

Selling Architectural Services II (3-S218)

This cassette (1975) examines the person-to-person selling process. It focuses on how to understand and work with your client's problem, achieving a mutually beneficial client-architect relationship. \$10/\$12.

Available through Publications Fulfillment Office (626-7332).

Setting Up an Architectural Firm (3-S229)

Cassette covering the wide range of considerations in setting up and running an architectural firm; including organization, business management, legal considerations, information resources, office machines. 90 minutes. \$10/\$12.

Available through Publications Fulfillment Office (626-7332).

Shelter (Environmental Communications)

100 color slides with booklet. Depicts various shelters from around the world; includes hand-built houses, yurts, domes, tents, cottages, barns and free-form sculptured dwellings. Rent \$15 to AIA members only.

Available through Audiovisual Department, Library (626-7495).

Slide Loans

The audiovisual librarian maintains a slide collection of approximately 12,000 slides. These slides are primarily on

American architecture, and include documentation of most AIA award-winning projects. No list is available of the collection, but the A/V librarian will select slides on specific subjects. Free loan to AIA members.

Contact Audiovisual Department, Library (626-7495).

Solar Architecture (Environmental Communications)

70 color slides with booklet. Shows in detail more than 20 existing structures that effectively use the sun's energy. Illustrates buildings with passive solar heating and buildings with various types of collectors and storage systems. Rent \$15 to AIA members only.

Available through Audiovisual Department, Library (626-7495).

Spaces for the Species

30-minute slide synchronized cassette tape presentation (1975) summarizing users' responses to various environments, such as a hotel, a school, an urban plaza and a shopping center. Free loan to AIA members only.

Available through Audiovisual Department, Library (626-7495).

Stations

16mm color film, 28 minutes (1974). Shows many of the interesting and innovative uses being made of old railroad stations, in order to preserve these landmarks. Rent \$15 to AIA members only. Available through Audiovisual Department, Library (626-7495).

10° Below

A light-hearted audiovisual presentation, prepared for AIA by the Minnesota Architectural Alliance, about energy and the built environment. 191 slides with music and dramatization in a synchronized tape. Two projectors are required. Free loan to AIA components.

Available through Audiovisual Department, Library (626-7495).

We Have to Be Able to Do It Ourselves

16mm color film discussing community design centers—what they are, what they do and why they work, featuring Philadelphia, Cleveland, New Orleans and San Francisco. Free loan.

Available through Audiovisual Department, Library (626-7495).

What Do They Have in Common?

Program Package 9 (4-N604)

Slide show of contemporary American ar-

chitecture designed by women. Included are informational handouts and guidelines for suggested use. The 80 slides run the gamut from solar homes to urban hospitals, from Manhattan to California. Can be shown without narration. \$20.

Available through Public Relations Department (626-7460) or Publications Fulfillment Office (626-7332).

Wilson R/UDAT

16mm color film, 25 minutes (1974). Documents the AIA Regional/Urban Design Assistance Team visit to Wilson, N.C. Free loan to AIA members only. Available through Audiovisual Department, Library (626-7495).

For further information about audio-tape cassettes, contact the Professional Development Programs Office, 626-7354.

Questions regarding film loans and audiovisual materials in general should be directed to the Audiovisual Department, Library (626-7495).

Awards

AIA/ACSA Award for Excellence in Architectural Education

Annually awarded for excellence in teaching architectural design or history. Nominators must be colleagues, students or former students of the candidate.

Contact Awards Division, Office of Assistant Secretary, 626-7390.

AIA/AFL-CIO Joint Craftsman Award Program

Biennial awards recognizing outstanding workmanship and the display of interest and ingenuity by the tradesman. Awarded to any journeyman or apprentice member of any of the building and construction trade unions of AFL/CIO.

Contact Awards Division, Office of Assistant Secretary, 626-7390.

AIA Honor Awards

Brochure describing the programs, including eligibility requirements, submission procedures, entry dates and fees, etc. Contains a tear-off entry slip. Free.

Contact Awards Division, Office of Assistant Secretary, 626-7390.

AIA Library Cross-Referenced Awards File

All AIA honor and merit awards have been indexed by date, place, architect, name of project and building type. The library staff can answer questions such as how many houses in Chicago have won AIA awards, etc.

Contact the Library, 626-7493.

Architectural Firm Award

Highest honor bestowed to a firm by the Institute. Awarded annually.

Contact Awards Division, Office of Assistant Secretary, 626-7390.

Celebrating American Architecture (4-N825)

Set of 80 slides depicting 1979 national honor award and 25-year award winning buildings. Script is included to provide brief descriptions of the structures and their award-winning qualities. \$18 pre-paid.

Available through Publications Fulfillment Office (626-7332).

Celebrating Excellence: Program Package 11 (6-N829)

A "how-to" guide that addresses AIA components interested in setting up successful awards programs. With documented examples from Florida Association/AIA, Houston Chapter/AIA and other components' efforts, this package provides basic information and guidelines for each step of the program. An insert of the AIA Board Guidelines for Component Awards Programs is included. Free to components.

Available through Public Relations Department (626-7460) or Publications Fulfillment Office (626-7332).

Concrete Reinforcing Steel Institute Design Awards Program

Biennial program sponsored by CRSI and open to site-cast reinforced concrete structures of all types. Material describing the design awards program. Free.

Available through the Awards Division, Office of Assistant Secretary (626-7390).

Homes for Better Living Awards

Brochure describing the annual award program open to custom-designed houses, merchant-built houses and multifamily housing in the U.S. and its possessions. Sponsored by AIA in conjunction with *Housing* magazine. Contains eligibility requirements, submission procedures, entry dates, etc., and a tear-off entry slip. Free.

Available through Awards Division, Office of Assistant Secretary (626-7390).

Information for Honor Award Program Entrants

Descriptive information, including a check list, on how to prepare binders and forms

for entry into AIA honor award programs, current and extended use. Automatically sent to all entrants who submit entry slips and checks for the program. Free.

Available through Awards Division, Office of Assistant Secretary (626-7390).

Institute Honors

Brochure describing the AIA program that recognizes distinguished achievements in the fine arts, industrial arts, architectural criticism and allied professions with the award of annual medals. Contains submission procedures, nomination forms, etc. Free.

Available through Awards Division, Office of Assistant Secretary (626-7390).

Library Buildings Award Program

Awards given for libraries designed in the U.S. or abroad by American architects. Sponsored by AIA in conjunction with the American Library Association. Libraries are judged in four categories: academic, public, school and state. Biennial.

Contact Awards Division, Office of Assistant Secretary, 626-7390.

List of Honor and Award of Merit Recipients

Chronological list of all the projects that have won AIA honor awards and awards of merit, including location and architect. Free.

Available through Awards Division, Office of Assistant Secretary (626-7390).

Louis Sullivan Award for Architecture

Brochure describing the biennial award for projects using masonry. Sponsored by International Union of Bricklayers and Allied Craftsmen and administered by AIA. Contains eligibility requirements, submission procedures, entry dates, etc., and a tear-off entry slip. Free.

Available through Awards Division, Office of Assistant Secretary (626-7390).

Naval Facilities Engineering Command Awards Program

Includes constructed architectural projects either for the Navy or other government agencies, so long as design and construction were administered by NACFAC. Projects may be submitted in various categories for naval facilities. Biennial.

Contact Awards Division, Office of Assistant Secretary, 626-7390.

Red Cedar Shingle & Handsplit Shake Bureau Design Awards

To honor architects demonstrating design excellence and significant functional or esthetic uses of cedar shingles or shakes. Annual.

Contact Awards Division, Office of Assistant Secretary, 626-7390.

Reynolds Aluminum Prize for Architectural Students

Brochure describing the annual award program open to students who have completed two years of architectural school. Sponsored by Reynolds Metals Co. and administered by AIA. Contains eligibility requirements, submission procedures, entry dates, etc. Free.

Available through Awards Division, Office of Assistant Secretary (626-7390).

R. S. Reynolds Memorial Award

Brochure describing the annual international award for architecture using aluminum. Sponsored by Reynolds Metals Co. and administered by AIA. Contains eligibility requirements, submission procedures, entry dates, etc., and a tear-off entry slip. Free.

Available through Awards Division, Office of Assistant Secretary (626-7390).

Slide Loans

The audiovisual librarian maintains a collection of 12,500 slides. These slides are primarily on American architecture, and include documentation of most AIA award-winning projects. No list is available of the collection, but the A/V librarian will select slides on specific subjects. Free loan to AIA members.

Contact Audiovisual Department, Library, 626-7495.

For further information about award programs in general, contact the Awards Division, Office of Assistant Secretary, 626-7390.

Barrier Free Architecture

Designing for the Physically Handicapped

Coordinates UBC and OSHA and other federal requirements. By James G. Burr, AIA. \$8 postpaid.

Available through Arizona Society of Architects/AIA, 1121 N. Second St., Phoenix, Ariz. 85004, (602) 257-1924.

Into the Mainstream: A Syllabus for a Barrier-Free Environment (3-M132)

44-page report (1975) by Stephen Kli-

ment, FAIA, containing practical information on how a community can achieve a barrier-free environment. \$2.75/\$3. *Available through Publications Fulfillment Office (626-7332).*

For further information about barrier-free architecture, contact the Codes & Standards Office, 626-7453.

Bibliographies

Bibliographies of AIA Library Holdings and Periodical Articles

The library staff will prepare on request bibliographies of library books and/or periodical articles on specific subjects or building types. Members can identify books they wish to borrow from these lists. Free. Photocopies: 20 cents per page. *Contact the Library, 626-7493.*

Bibliographies of Audio-Visual Materials Available Through Sources Other Than AIA

The audiovisual librarian will supply on request bibliographies of A/V materials on various architecture and planning topics. Materials listed have not been screened.

Contact Audiovisual Department, Library, 626-7495.

Bibliography of Bibliographies

Four-page list (1981) of subject bibliographies compiled by the library staff. Contains over 200 subjects on which bibliographies of the library's holdings and/or periodical articles have been prepared. Free.

Available through the Library (626-7493).

Environmental Education Teaching Tools

40-page annotated catalog (1975) prepared by the environmental education committee, listing information on resources (books, games, films, etc.) for environmental education. Free.

Available through the Director, Environmental Education (626-7573).

Environmental Impact Statements Bibliography

Four-page selected and annotated bibliography (1975) prepared by the AIA com-

mittee on architecture for commerce and industry. Free.

Available through the Library (626-7493).

Recent Accessions

Bimonthly list of recent library acquisitions, arranged by subject. Free.

Available through the Library (626-7493).

Value Engineering and Life Cycle

Bibliography

Four-page selected and annotated bibliography (1975) prepared by the AIA committee on architecture for commerce and industry. Free.

Available through the Library (626-7493).

Building Costs

Life Cycle Cost Analysis: A Guide for Architects (2-M708)

Provides architects, engineers and clients with a straightforward and usable technique allowing them to consider all relevant economic consequences of design decisions (1978). A primer prepared by the life cycle cost analysis task force of AIA. \$10/\$12.50.

Available through Publications Fulfillment Office (626-7332).

Life Cycle Cost Analysis 2: Using It in Practice (2-M713)

Responds to the critical question: Where in the planning and design process can the life cycle cost analysis technique be effectively used? (1978.) Provides guidelines for selecting application areas and a number of case study applications, as well as commentary on the planning and design process. For use with the first life cycle guide. \$14.50/\$18.

Available through Publications Fulfillment Office (626-7332).

Value Engineering and Life Cycle

Bibliography

Four-page selected and annotated bibliography (1975) prepared by the AIA committee on architecture for commerce and industry. Free.

Available through the Library (626-7493).

For further information about building costs in general, contact the Practice Department, 626-7454.

Building Evaluation

Building Evaluation (3-S212)

Cassette explaining how to better meet human needs in design through evaluation of existing environments. 45 minutes. \$10/\$12.

Available through Publications Fulfillment Office (626-7332).

Building Types

Bibliographies of AIA Library Holdings and Periodical Articles

The library staff will prepare on request bibliographies of library books and/or periodical articles on specific subjects or building types. Members can identify books they wish to borrow from these lists. Free. Photocopies: 20 cents per page.

Contact the Library, 626-7493.

Spaces for the Species

30-minute slide synchronized cassette tape presentation (1975) summarizing users' responses to various environments, such as a hotel, a school, an urban plaza and a shopping center. Free loan to AIA members only.

Available through Audiovisual Department, Library (626-7495).

Careers in Architecture

Architectural Career Awareness Package (3-M401)

80 color slides with script for use by high school counselors or architects lecturing groups of prospective architects. Includes "Architecture Schools in North America" and assorted pamphlets. \$27/\$30.

Available through Association of Student Chapters/AIA at AIA Headquarters (626-7472), or Publications Fulfillment Office (626-7332).

Architectural History Syllabus

A collection of history notes and tips and pointers for candidates preparing for the history portion of the equivalency examination. \$15, including tax and postage. *Available through Cabrillo Chapter/AIA, 121 Linden Ave., Long Beach, Calif. 90802, (213) 432-9817.*

Career Alternatives (6-N209)

Prepared by the architects in industry committee, this pamphlet discusses expanding opportunities for architects in nontraditional careers. Free.

Available through Publications Fulfillment Office (626-7332).

Career Profile: Architect (6-N207)

Publication (1980) aimed at the intermediate and high school students who want general information on the profession of architecture. It provides information on education, internship, salaries, practice, and a list of reading material and sources for more answers. Free.

Available through Education Office (626-7349) or Publication Fulfillment Office (626-7332).

Careers in Architecture (1-HBC4)

Chapter 4 (1972) of the Architect's Handbook of Professional Practice, this document covers the architect's profession, education and training; the architect in practice; AIA; Association of Collegiate Schools of Architecture; National Architectural Accrediting Board, and the National Council of Architectural Registration Boards. \$1.20/\$1.80.

Available through Publications Fulfillment Office (626-7332).

Counseling for Architectural Careers

Students desiring basic architectural career information are counseled by the Education and Professional Development Department staff. Counseling may be in person or by letter.

Contact Education Office, 626-7349.

What Do They Have in Common?

Program Package 9 (4-N604)

Slide show of contemporary American architecture designed by women. Included are informational handouts and guidelines for suggested use. The 24 slides run the gamut from solar homes to urban hospitals, from Manhattan to California. Can be shown without narration. \$20.

Available through Public Relations Department (626-7460) or Publications Fulfillment Office (626-7332).

For further information about careers in architecture, contact the Education Office, 626-7349.

Codes & Standards

Building Codes and Standards List

Annual comprehensive list of nationally used codes and standards, including publishers, addresses and prices. Free.

Available through Codes and Standards Office (626-7456).

Co

Educating the Architect: Fire and Life Safety

33-page report (1975) prepared by the AIA task group on fire and life safety, documenting the need for better firesafety curricula in education, and a program to implement the proposed recommendations. Free.

Available through Codes and Standards Office (626-7456).

One Code: A Program for Building Regulatory Reform

43-page report (1975) prepared by the AIA task group on building regulation, detailing a mechanism for achieving building code uniformity in the U.S. Free.

Available through Codes and Standards Office (626-7456).

Prescriptive Standards: No Rx for Energy Conservation in Buildings (6-N816)

Folder (1976) promoting performance-oriented standards for energy conservation, rather than prescriptive standards. Free.

Available through Publications Fulfillment Office (626-7332).

For further information about codes and standards in general, contact the Codes and Standards Office, 626-7456.

Community Centers

We Have To Be Able To Do It Ourselves

16mm color film discussing community design centers—what they are, what they do and why they work, featuring Philadelphia, Cleveland, New Orleans and San Francisco. Free loan.

Available through Audiovisual Department, Library (626-7495).

Community Development

Community Development Block Grants: Opportunities for Shaping Urban Growth

17-page publication (revised 1978) that identifies for local government officials and concerned citizens provisions of Title I which provide opportunities for implementing AIA's principal urban growth policy recommendations. Free.

Available through Government Affairs Office (626-7375).

Involving Architects in the Community Development Block Grant Programs:

A Strategy Guide For AIA Components

For component use, provides guidance in the CD block grant planning and application process to encourage local AIA involvement in the programs. Free.

Available through Government Affairs Office (626-7375).

For further information about community development, contact the Minority Resources Office (626-7434).

Competitions

ASC/AIA Student Competitions

Several competitions are held each year. Contact Association of Student Chapters/AIA, at AIA Headquarters, 626-7472.

Competition 1792: Designing a Nation's Capitol

Catalog from Octagon exhibition on history of the 1792 competition for the United States Capitol. Catalog contains extensive information and illustrations on all the competitors. \$3.75.

Available through the Octagon, 1799 New York Ave. N.W., Washington, D.C. 20006 (638-3105).

Design Competitions Archive

AIA library competitions archive is a repository for the documentary material (excluding drawings) generated by architectural design competitions. Sponsors and/or professional advisers of recent competitions should send the archive copies of competition announcements, press releases, photographs of winning designs, publications, etc. Drawings should be donated to local libraries or archives.

Contact the Library, 626-7493.

Handbook of Architectural Design Competition (6-J500)

The AIA's detailed advice regarding the proper conduct of design competitions. Free.

Available through Design Department (626-7363) or Publications Fulfillment Office (626-7332).

House of Tiles Competitions Catalog

Catalog of the 1979 ASC/AIA and the Tile Council of America design competition. The catalog contains jury comments and the winning entries, as well as more than 40 other selected entries. \$5.

Available through the Association of Student Chapters/AIA at AIA Headquarters (626-7472).

McDonald's Competition: The Most Innovative McDonald's of the Future

Catalog of the ASC/AIA McDonald's design competition, offering comments from jury members, photographs and de-

scriptions of the winning entries, and other sample entries. \$5.

Available through the Association of Student Chapters/AIA at AIA Headquarters (626-7472).

For further information about competitions in general, contact Design and Environment Programs Office, 626-7363.

Components, AIA

The AIA Asks: Why? Why Not?:

Program Package 1 (6-N807)

25-page package (1974) that explains how to place a series of pictures and captions about good and bad environmental features in local newspapers. Describes the program, gives ideas for pictures and captions, provides "how-to" information about approaching the newspaper, etc. Free to component executives and public relations committee chairmen.

Available through Publications Fulfillment Office (626-7332) or Public Relations Department (626-7460).

AIA Component Clearinghouse

Service providing components with information on operations and numerous programs, including associate members in chapter programs, homeowners' clinics, component speakers' bureaus, Women's Architectural Leagues, sources of non-dues income for chapter programs and establishing a component foundation. Free.

Available through the Component Services Office (626-7377).

AIA Component Profile (6-N610)

Comprehensive survey report (December 1979) on the characteristics of AIA components and the programs and services they provide to their members and communities. Based on data collected from 208 AIA components from May to August 1979. Free.

Available through Component Services Office (626-7377).

AIA Component Profile Supplement

Charts the programs and services provided by state and local components and includes a list of component budgets, publications, membership brochures and job descriptions available from the AIA component clearinghouse (January 1980). *Available through Component Services Office (626-7377).*

Built Environment Education: Program Package 10 (6-N824)

Folder highlighting a built environment education program for elementary school

students developed and implemented by an architect. Includes a step-by-step sample program outline, plus a guide to resources and information on built environment education. Free to component executives and public relations committee chairmen.

Available through Publications Fulfillment Office (626-7332) or Public Relations Department (626-7460).

Celebrating Excellence: Program Package 11 (6-N829)

A "how-to" guide that addresses AIA components interested in setting up successful awards programs. With documented examples from Florida Association/AIA, Houston Chapter/AIA and other components' efforts, this package provides basic information and guidelines for each step of the program. An insert of the AIA Board Guidelines for Component Awards Programs is included. Free to components.

Available through Public Relations Department (626-7460) or Publications Fulfillment Office (626-7332).

A Celebration of Architecture: 25 Ideas for Components

Slide show and script that briefly describe 25 ways for AIA components to focus the public's attention on the built environment. The show outlines projects used to implement AIA's 1979 Celebration of Architecture program—tours, exhibits, guidebooks, etc. An "idea-kit" for components looking for PR projects to undertake. Free loan to components.

Available through Public Relations Department (626-7460).

Component Assistance Teams (CATS)

Teams composed of AIA members, staff and/or component executives, formed on an ad hoc basis when requested by a component. Purpose is to advise on internal (organizational) or external problems. *Contact Component Affairs Office, 626-7378.*

Component Charter Form

Application to be submitted by members requesting chapter status within AIA; to be used in the formation of any new chapter. Free.

Available through Component Services Office (626-7377).

Component Editors Critique Service

A program to help improve the skills of editors of component newsletters and

magazines. Critiques by graphic and editorial consultants are available on request. *Contact Public Relations Department, 626-7460.*

Component Executives—Do We Need One? (6-N608)

Brochure designed for component leaders who may be considering employing a component executive. Describes what an executive does and how a skilled manager can help elected leaders make the organization a more successful professional association. Discusses budget considerations and staff alternatives. Prepared by the Council of Architectural Component Executives (CACE). Free. Maximum 10 copies per component.

Available through Component Services Office (626-7377).

Component PR Assistance/Counseling

A program that offers different kinds of PR information, program packages, counseling and other aids to help components solve individual PR problems.

Contact Public Relations Department, 626-7460.

Component Presidents' Planning Manual

Descriptive manual on yearly chapter operations, including planning, programming and budgeting techniques. Free. One per chapter.

Available through Component Services Office (626-7377).

Disaster Assistance Programs: A Strategy Guide for AIA Components

Describes how components of AIA can organize and implement disaster relief programs at the state and local levels. Emphasizes long-term planning and how architects can work with state and other volunteer organizations (Jan. 1979).

Available through Government Affairs Office (626-7375).

Effective Public Relations

A manual geared specifically to the needs of the component PR chairmen. It spells out the basic principles of PR planning and offers suggestions for effective use of the media and increasing a component's visibility. Free to component executives and PR chairmen.

Available through Public Relations Department (626-7460).

Environments for People: Program Package 5 (4-N812)

80 slides, introduction, script and suggestions for use (1976). Explains how architects provide for basic human needs (shelter, privacy, personalization, socializing, mobility, communication) in their design of the human environment. \$20 prepaid.

Available through Publications Fulfillment Office (626-7332) or Public Relations Department (626-7460).

Grassroots

An annual leadership conference held each year that brings component officers and executives together with national officers and staff. Purpose is to review and discuss national programs and policies, give component leaders an opportunity to provide input into the national planning process and provide a forum for the exchange of ideas among components.

Contact Component Services Office, 626-7376.

Guidelines for Component Bylaws

Assistance with component bylaws.

Contact Component Affairs Office, 626-7378.

Houston Architecture April Festival: Program Package 7 (6-N831)

A folder (1976) explaining how the Houston Chapter/AIA held a month-long festival to increase public awareness and appreciation of architecture and architects. Includes descriptions of individual events, their planning, cost and publicity. Illustrated with news clips about the festival and samples of poster, tickets and map graphics used by the chapter. Free to component executives and public relations chairmen.

Available through Publications Fulfillment Office (626-7332) or Public Relations Department (626-7460).

How Architecture Speaks: Program Package 2 (4-N808)

43 slides, guidelines, script and quiz sheets (1974) that show people how architecture "speaks" through form, color, scale, texture, materials. Quiz tests people's reactions to structures. \$18 prepaid.

Available through Publications Fulfillment Office (626-7332) or Public Relations Department (626-7460).

Indianapolis Architecture Guidebook: Program Package 8 (6-N832)

Folder (1977) describing the process by which Indianapolis Chapter/AIA published an extensive guidebook of that city. Includes sections on why to write a guidebook, forming a committee, fund-raising, budgeting, selecting printer and designer and publicizing the project and the product. Free to component executives.

Available through Publications Fulfillment Office (626-7332) or Public Relations Department (626-7460).

Co

A Line on Design and Energy: Ways to Make it Happen

80 slides and script for use by components for developing visibility programs within their communities to promote the "Line on Design and Energy" theme. Free loan to components.

Available through Audiovisual Department, Library (626-7495).

Membership Forms/H Series

The following forms are intended for components' use. Free.

- H301 Application for Membership
- H302 Application for Associate Membership
- H303 Recommendation of Chapter on Application for Membership
- H304 Application for Chapter Transfer
- H306 Application for Membership (for use only by present associate members of the AIA)
- H307 Application for Membership (for use only by former AIA members)
- H341 Application for Student Affiliate Membership
- H351 Application for Professional Affiliateship
- H601 Application for Membership Emeritus

Available through Membership Procedures Division, Office of Assistant Secretary (626-7393).

Mini-Grassroots

Program of 45 minutes to one and a half hours, designed to aid components in programming. Gives overview of AIA services and benefits to members and augments local members with national staff. Can be combined with membership recruitment activities. Free.

Contact Component Services Office, 626-7376.

Orchids and Onions: Program Package 4 (6-N811)

Folder (1975) explaining how components can carry on a program which asks the public to nominate organizations and individuals who make good or bad contributions to the man-made environment; a jury selects the winners. Based on a project of the Western Communities Architects' Association, a section of the Chicago Chapter/AIA. Free to component executives and public relations chairmen. *Available through Publications Fulfillment Office (626-7332) or Public Relations Department (626-7460).*

Organizational Directory (4-P105)

Annual directory of AIA officers and committees, component officers and executives. Shows organizational structure of Institute. Includes a list of related architectural organizations. Free to component officers and executives. \$6 to AIA members only.

Component officers and executives contact the Component Services Office, 626-7376. Members contact Publications Fulfillment Office, 626-7332.

A Public Relations Idea Kit: "A Line on Design and Energy"

Explores ways for components to make the most of the design and energy theme at the local level. It contains ideas for component programs and activities—energy fairs, tours, articles, displays, TV and radio spots and more. Free to component executives or PR chairmen.

Available through Public Relations Department (626-7460).

Sample Articles for Components

A collection of sample articles to help AIA components encourage newspaper editors to run regular columns on architecture in local papers. Each article discusses a different aspect of architecture of interest to the public. Free to components.

Available through Public Relations Department (626-7460).

Sample TV and Radio Public Service Announcements

A "how to" packet on PR planning and effective use of public service announcements. Contains five sample PSAs. Free to component executives and PR chairmen.

Available through Public Relations Department (626-7460).

Schedule: Regional and State Conventions and Expositions

Annual schedule of meetings to be held by components, including place, expected attendance and contacts. Free.

Available through Convention Office (626-7395).

Women in Architecture: A Special Report

Eight-page special issue of the AIA Memo (January 1976) that describes the AIA's affirmative action plan to increase involvement of women in AIA and the profession. Free.

Available through Public Relations Department (626-7460).

Women's Architectural Leagues

Organized to promote and advance public awareness of architecture and to complement the activities of local AIA components. WAL has chapters throughout the country and holds a national meeting in

conjunction with the annual AIA convention. Interested persons and components may obtain a roster of WAL chapters and information on local chapter activities.

Available through Component Services Office (626-7377).

You and Your Component Executive (6-N607)

Brochure written for component officers and directors, identifies major areas of responsibility of both component executives and components themselves with respect to their executives. Prepared by the Council of Architectural Component Executives (CACE). Free.

Available through Component Services Office (626-7376).

For further information about component government programs, contact Government Affairs Office, 626-7375.

Computer Applications

CFMS—Computer Based Financial Service

Six-page brochure by the system operator, Harper & Shuman, Inc., describing the Institute's multifaceted computer based system for design professionals. Explains how CFMS provides detailed, understandable financial reports. Free.

Contact PSAE, a wholly owned corporation of AIA, at AIA Headquarters, 626-7550.

For further information about computer applications in general, contact the Practice Department, 626-7457. Questions regarding MASTERSPEC should be directed to Productions Systems for Architects and Engineers, Inc. (PSAE), at AIA Headquarters, 626-7550.

Construction Industry

All Weather Construction

65 color slides with tape cassette and script explaining techniques for cold weather masonry construction. Free loan to AIA members.

Available through Audiovisual Department, Library (626-7495).

Construction Bonds and Insurance Guide, 2nd edition (2-M163)

Loose-leaf reference book (1979) prepared by Bernard B. Rothschild, FAIA, containing information on bonds and insurance related to construction projects, with glossary of insurance terms and suggested check list. \$16/\$20.

Available through Publications Fulfillment Office (626-7332).

The Construction Industry (1-HBC2)

Chapter 2 (1969) of the Architect's Handbook of Professional Practice, this document includes information on the industry, the owner, the design professions, the constructors and related elements, special types of construction services, comprehensive architectural services and building organizations. \$.60/\$.90.

Available through Publications Fulfillment Office (626-7332).

Design and Construction Methods (6-N410)

Prepared by the AIA committee on architecture for commerce and industry, this pamphlet provides a summary of the most prevalent approaches to getting a building project designed and constructed. Design/award/build, fast track and the design team approach are only three of the options available to the architect as an owner. Free.

Available through Publications Fulfillment Office (626-7332).

Glossary of Construction Industry Terms (2-M101)

18-page publication (1970), including definitions of terms with special meaning or connotation in the construction industry. \$1.25/\$1.50.

Available through Publications Fulfillment Office (626-7332).

Construction Management**Construction Cost Analysis (1-HBC15)**

Chapter 15 (1970) of the Architect's Handbook of Professional Practice, this document covers considerations in cost analysis, statements of probable construction cost, project cost records, cost analysis methods, variables and aids. \$.60/\$.90.

Available through Publications Fulfillment Office (626-7332).

Design/Build/Bid: An Owner's Guide (6-N903)

Booklet (1975) intended to assist a po-

tential client in the public sector in evaluation of the design-build-bid process. Free.

Available through Publications Fulfillment Office (626-7332).

Project Delivery Approaches: An AIA Guide (2-M702)

30-page publication (1976) edited by David S. Haviland of the AIA project management systems task force. This guide is essentially a primer and is planned as the nucleus and framework for AIA development of a series of studies and guidelines for responsive and creative project delivery approaches. \$3.25/\$4.

Available through Publications Fulfillment Office (626-7332).

Value Engineering and Life Cycle**Bibliography**

Four-page selected and annotated bibliography (1975) prepared by the AIA committee on architecture for commerce and industry. Free.

Available through Library (626-7493).

For further information about the use of construction management documents, contact the Documents Office, 626-7440.

Contract Information**The AIA Handbook (1-HBC1)**

Chapter 1 (1973) of the Architect's Handbook of Professional Practice, this document includes general information on the Handbook, including the preface, table of contents, general index and information on chapters. \$.60/\$.90.

Available through Publications Fulfillment Office (626-7332).

Architect's Handbook of Professional Practice (1-M104)

This three-volume set in ring binders includes samples of all A, B, C, D, E and G series documents, plus 20 chapters and a glossary of construction industry terms. \$30/\$45 (1-M104). Contents only (no binders), \$20/\$30 (1-M104A). Three binders (no contents), \$10/\$15 (1-M104B). Individual chapters of the handbook are listed under **AIA Documents**, and described under the subjects they cover.

Available through Publications Fulfillment Office (626-7332).

Architect's Handbook of Professional Practice—Supplement Service (4-Z100)

Subscriptions to the Supplement Service bring the latest editions of the documents contained in the handbook directly to subscribers. \$16.

Available through Publications Fulfillment Office (626-7332).

Construction Contract Administration (1-HBC18)

Chapter 18 (1973) of the Architect's Handbook of Professional Practice, this document covers the division of responsibility, the project representative, contract documents, construction documents, project inception, administration, termination, post completion, notes on certain projects and AIA contract administration documents. \$1.20/\$1.80.

Available through Publications Fulfillment Office (626-7332).

General Conditions of the Contract for Construction (1-HBC13)

Chapter 13 (1970) of the Architect's Handbook of Professional Practice, this document outlines the history of the AIA General Conditions, its use, comments on A201, A201/SC federal edition, A107 and supplementary conditions. \$1.20/\$1.80.

Available through Publications Fulfillment Office (626-7332).

Owner-Contractor and Contractor-Subcontractor Agreements (1-HBC17)

Chapter 17 (1973) of the Architect's Handbook of Professional Practice, this document covers stipulated sum agreements, short form agreements, cost plus fee agreements, execution of agreements, letters of intent, service documents, etc. \$1.20/\$1.80.

Available through Publications Fulfillment Office (626-7332).

Selection of Contractors (1-HBC-16)

Chapter 16 (1971) of the Architect's Handbook of Professional Practice, this document covers objectives and procedures, bidding documents, methods of awarding contracts, the contract system, types of contracts, examination of pre-qualification of bidders, preparation and receipt of bids, awarding and executing the contracts. \$.60/\$.90.

Available through Publications Fulfillment Office (626-7332).

For further information about contract documents in general, including their use and interpretation, contact the Documents Office, 626-7440. Orders for individual documents (listed in this guide under AIA Documents) should be directed to the Publications Fulfillment Office, 626-7332, or your local distributor for AIA contracts and forms, listed on page 136.

Contracts and Documents

Documents may be obtained from the AIA Publications Fulfillment Office, 1735 New York Ave. N.W., Washington, D.C. 20006, or from your authorized local distributor for AIA contracts and forms. **All document orders should be directed to your local distributor if you reside in one of the following states:** Alabama, Arizona, California, Colorado, Connecticut, Florida, Georgia, Hawaii, Idaho, Illinois, Indiana, Iowa, Kansas, Kentucky, Louisiana, Massachusetts, Michigan, Minnesota, Mississippi, Missouri, Montana, Nebraska, New Jersey, New Mexico, New York, North Carolina, Ohio, Oklahoma, Oregon, Pennsylvania, Rhode Island, South Dakota, Tennessee, Texas, Utah, Washington, West Virginia and Wisconsin.

For faster service, you are encouraged to contact the local distributor in your area when ordering AIA documents. A complete list of distributors is on page 136.

Because AIA documents in the A-G Series and all chapters from the Architect's Handbook of Professional Practice are revised regularly, some may have been superseded by new editions. Editions listed are the latest available.

The following instructions apply only when ordering from AIA in Washington, D.C. Documents may be ordered by letter furnishing the following information:

1. Your name, correct mailing address and component/chapter affiliation (if applicable).
2. Quantity, document number and price of each document you wish to order.
3. Check or money order payments **MUST** accompany all orders totalling \$20 or less in costs **AND** all nonmember orders.
4. District of Columbia residents add 6 percent sales tax to cost of documents purchased.
5. For first class, airmail, special delivery, air express handling, add 20 percent to total dollar amount of items ordered.
6. All orders from Canada, the West Indies and Latin America must be accompanied by check or money order payable in U.S. dollars. Payment must include postage in the amount of 20 percent added to dollar amount of documents ordered.

All orders from countries other than U.S., Canada, the West Indies and Latin America should be directed to: RIBA Publications Limited, 66 Portland Place, London, W1N 4AD, England. PUBS has been appointed agent and distributor for publications and visual aids produced by AIA in the following countries and territories: United Kingdom and Northern Ireland, Republic of Ireland, Europe, Republic of South Africa, the Middle East and member countries of the British Commonwealth. Foreign architects electing to become AIA correspondent members may order documents from either AIA in Washington, D.C., or PUBS in London.

		Non-Member Price	Member Price
A SERIES/Owner-Contractor Documents			
A101	Owner-Contractor Agreement Form—Stipulated Sum (6/77) with instruction sheet wrapped	\$.80	\$.55
A101 /CM	Owner-Contractor Agreement Form—Stipulated Sum—Construction Management Edition (6/80) with instruction sheet wrapped80	.55
A107	Short Form for Small Construction Contracts—Stipulated Sum (4/78) with instruction sheet wrapped80	.55

		Non-Member Price	Member Price
A111	Owner-Contractor Agreement Form—Cost Plus Fee (4/78) with instruction sheet wrapped80	.55
A117	Abbreviated Owner-Contractor Agreement Form—Cost Plus Fee (3/79) with instruction sheet wrapped80	.55
A171	Owner-Interiors Contractor Agreement Form (3/79) with instruction sheet wrapped70	.50
A177	Abbreviated Owner-Contractor Agreement for Furniture, Furnishings and Equipment (5/80) with instruction sheet wrapped80	.55
A201	General Conditions of the Contract for Construction (8/76)	1.75	1.25
A201 /CM	General Conditions of the Contract for Construction—Construction Management Edition (6/80)	2.00	1.35
A201 /SC	General Conditions of the Contract for Construction and Federal Supplementary Conditions of the Contract for Construction (8/77)	2.00	1.35
A271	General Conditions of the Contract for Furniture, Furnishings and Equipment (12/77) with instruction sheet wrapped	1.50	1.00
A305	Contractor's Qualification Statement (3/79)70	.50
A310	Bid Bond (2/70)20	.15
A311	Performance Bond and Labor and Material Payment Bond (2/70)		
A311 /CM	Performance Bond and Labor and Material Payment Bond—Construction Management Edition (6/80)35	.25
A331	Withdrawn		
A401	Contractor-Subcontractor Agreement Form (4/78)50	.35
A501	Recommended Guide for Bidding Procedures and Contract Awards (11/69)	1.80	1.25
A511	Guide for Supplementary Conditions (7/80)	2.00	1.35
A521	Uniform Location Subject Matter (1977)	2.00	1.35
A701	Instructions to Bidders (5/78) with instruction sheet wrapped80	.55
A771	Instructions to Interiors Bidders (5/80) with instruction sheet wrapped80	.55

B SERIES/Owner-Architect Documents

B141	Standard Form of Agreement Between Owner and Architect (7/77) with instruction sheet wrapped80	.55
B141 /CM	Standard Form of Agreement Between Owner and Architect—Construction Management Edition (6/80) with instruction sheet wrapped80	.55

		Non-Member Price	Member Price
B151	Abbreviated Owner-Architect Agreement Form (6/78) with instruction sheet wrapped	.70	.50
B161	Standard Form of Agreement Between Owner and Architect for Designated Services (11/77) with instruction sheet wrapped	.70	.50
B162	Scope of Designated Services (11/77) with instruction sheet wrapped	2.75	1.85
B171	Standard Form of Agreement for Interior Design Services (3/79)	.70	.50
B171A	Instruction Sheet	N/C	N/C
B177	Abbreviated Interior Design Services Agreement (5/80) with instruction sheet wrapped	.80	.55
B181	Owner-Architect Agreement for Housing Services (6/78) with instruction sheet wrapped	.70	.50
B352	Duties, Responsibilities, and Limitations of Authority of the Architect's Project Representative (5/79)	.30	.20
B431	Architect's Qualification Statement (12/79)	.80	.55
B727	Standard Form of Agreement Between Owner and Architect for Special Services (6/79) with instruction sheet wrapped	.80	.55
B801	Standard Form of Agreement Between Owner and Construction Manager (6/80) with instruction sheet wrapped	.80	.55
C SERIES/Architect-Consultant Documents			
C141	Standard Form of Agreement Between Architect and Engineer (6/79) with instructions wrapped	.80	.55
C161	Standard Form of Agreement Between Architect and Consultant (6/79) with instructions wrapped	.80	.55
C431	Standard Form of Agreement Between Architect and Consultant for other than Normal Engineering Services (3/72)	.70	.50
C801	Joint Venture Agreement (6/79) with instructions wrapped	.80	.55
D SERIES/Architect-Industry Documents			
D101	Architectural Area and Volume of Buildings (1/80)	.25	.17
D200	Project Checklist (5/73)	1.80	1.25
E SERIES/Architect-Producer Documents			
E101	Technical Literature for the Construction Industry (7/72)	.70	.50
F SERIES/Architect's Accounting Forms—Manual System			
25 SHEETS PER UNIT			
F101	Cash Journal—1949	2.75	1.85

		Non-Member Price	Member Price
F102	Cash Journal—1949	2.75	1.85
F103	Cash Journal—1949	2.75	1.85
F104	Cash Journal—1953	2.75	1.85
F105	Cash Journal—1949	2.75	1.85
F106	Cash Journal—1949	2.75	1.85
F107	Journal Form—1949	2.75	1.85
F201	Payroll Journal—1953	2.75	1.85
F202	Payroll Journal—1949	2.75	1.85
F203	Payroll Journal—1949	2.75	1.85
F301	Ledger Account Form—1949	2.75	1.85
F401	Job Expense Record Form—1953	2.75	1.85
F402	Employee Record Form—1953	2.75	1.85
F403	Fixed Assets Record—1949	2.75	1.85
F404	Note and Investment Record—1949	2.75	1.85
50 SHEETS PER UNIT			
F501	Trial Balance—1953	4.50	3.00
F502	Balance Sheet—1953	4.50	3.00
F503	Profit and Loss Statement—1949	4.50	3.00
F504	Indirect Expense Factor—1953	4.50	3.00
F601	Time Record Sheet—1971	5.00	3.35
F603	Expense Voucher Nonpersonnel—1953	4.50	3.00
F605	Expense Record—1953	4.50	3.00
F701	Billing Extract—1972	4.50	3.00
F703	Aged Accounts Receivable—1972	4.50	3.00
F712	Project Payroll Cost Worksheet—1972	4.50	3.00
F714	Detail of Expenses—1972	4.50	3.00
F716	Time Distribution Summary—1972	4.50	3.00
F721	Project Estimating and Budget Worksheet—1972	4.50	3.00
F723	Project Progress Report—1972	4.50	3.00
F725	Project Summary Report—1972	4.50	3.00
F SERIES/Compensation Guidelines Forms and Worksheets			
F800	F810 thru F860 (1978) Completed Set of 2 Each of 24 Forms Needed	6.00	4.00
25 SHEETS PER UNIT			
F810	Scope of Designated Service Worksheet (unphased)	2.40	1.60
F820	Phase Compensation Worksheet (unphased)	2.40	1.60
F850	Project Time and Payment Schedule	2.40	1.60
F SERIES/Standardized Accounting For Architects Forms			
25 SHEETS PER UNIT			
F1001	Cash Receipts Journal (1978)	2.40	1.60
F1002	Cash Disbursements Journal (1978)	2.40	1.60
F1004	Trial Balance (1978)	2.40	1.60
F1006	Balance Sheet and Income and Expense Statement (1978)	2.40	1.60
F2002	Fixed Assets Record (1978)	2.40	1.60
F2004	Notes and Investment Record (1978)	2.40	1.60
F3003	Payroll Journal (1978)	2.40	1.60
F3005	Staff Payroll Record (1978)	2.40	1.60
F4001	Project Time Distribution (1978)	2.40	1.60
F4003	Project Expense Record (1978)	2.40	1.60
F5001	Billing Extract (1978)	2.40	1.60

		Non-Member Price	Member Price			Non-Member Price	Member Price
F5003	Aged Accounts Receivable (1978) ..	2.40	1.60	G723	Project Application Summary (6/80) with instructions	5.50	3.75
F6001	Ledger Account (1978)	2.40	1.60	G801	Application for Employment (6/75)	4.50	3.00
F6002	Journal (1978)	2.40	1.60	G804	Register of Bid Documents (4/70) ..	4.50	3.00
F6003	Accounting Worksheet (1978)	2.40	1.60	G805	List of Subcontractors (4/70)	4.50	3.00
F6004	Accounting Worksheet (1978)	2.40	1.60	G807	Project Directory (4/70)	4.50	3.00
	50 SHEETS PER UNIT			G809	Project Data (4/70)	4.50	3.00
F2001	Expense Voucher (1978)	4.50	3.00	G810	Transmittal Letter (4/70)	4.50	3.00
F3001	Time Record (1978)	4.50	3.00	G811	Employment Record (11/73)	4.50	3.00
F3002	Staff Expense Record (1978)	4.50	3.00	G813	Temporary Placement (1/74)	4.50	3.00
F5002	Invoice for Architectural Services (1978)	4.50	3.00				
G SERIES/Architect's Office and Project Forms				Architect's Handbook of Professional Practice—Chapters			
	These forms have been greatly expanded and are now sold individually			HBC 1	The AIA Handbook—197390	.60
G601	Land Survey Requisition (6/79) with instructions70	.50	HBC 2	The Construction Industry—1969 ..	.90	.60
G602	Soil Investigation and Engineering Services Agreement (6/79) with instructions70	.50	HBC 3	AIA and Related Organizations— 1972	1.80	1.20
G610	Owner's Instructions for Bonds and Insurance (11/78)40	.27	HBC 4	Careers in Architecture—1972	1.80	1.20
	50 SHEETS PER UNIT			HBC 6	Replaced HBC/B-1		
G604	Change Authorization for Professional Services (3/79) with instructions ..	5.50	3.75	HBC 7	Insurance and Bonds of Suretyship— 1969	1.80	1.20
G701	Change Order (4/78)	4.50	3.00	HBC 10	Interprofessional Agreements—1975	.90	.60
G701	Change Order—Construction /CM Management Edition (6/80)	5.00	3.35	HBC 11	Project Procedures—1969	1.80	1.20
G702	Application and Certificate for Payment (4/78)	5.00	3.35	HBC 12	Construction Documents— Drawings—197090	.60
G703	Continuation Sheet for G702 (4/78)	5.00	3.35	HBC 13	General Conditions of the Contract for Construction—1977	1.80	1.20
G704	Certificate of Substantial Completion (4/78)	4.50	3.00	HBC 14	Construction Documents— Specifications—1972	1.80	1.20
G705	Certificate of Insurance (11/78)	4.50	3.00	HBC 15	Construction Cost Analysis—1970 ..	.90	.60
G706	Contractor's Affidavit of Payment of Debts and Claims (4/70)	4.50	3.00	HBC 16	Selection of Contractors—197190	.60
G706A	Contractor's Affidavit of Release of Liens (4/70)	4.50	3.00	HBC 17	Owner-Contractor and Contractor- Sub-contractor Agreements—1973	1.80	1.20
G707	Consent of Surety to Final Payment (4/70)	4.50	3.00	HBC 18	Construction Contract Administration—1973	1.80	1.20
G707A	Consent of Surety to Reduction in or Partial Releases of Retainage (6/71)	4.50	3.00	HBC 19	Legal Concerns—1969	1.80	1.20
G709	Proposal Request (4/70)	4.50	3.00	HBC 21	The Architect as Preservationist— 197190	.60
G710	Architect's Supplemental Instructions (3/79) with instructions	5.50	3.75	HBC/	The Architect's Office— B-1 1980	2.25	1.50
G711	Architect's Field Report (10/72)	4.50	3.00	HBC/	Marketing Architectural Services— B-8 1980	2.25	1.50
G712	Shop Drawing and Sample Record (10/72)	4.50	3.00	HBC/	The Architect's Communications— B-9 1980	2.25	1.50
G713	Construction Change Authorization (3/79) with instructions	5.50	3.75				
G722	Project Application and Project Certificate for Payment (6/80) with instructions	5.50	3.75	Architect's Handbook of Professional Practice			
				M104	Architect's Handbook of Professional Practice (Set of 3 Volumes)	45.00	30.00
				M104A	Architect's Handbook/ <i>Contents</i> <i>Only</i>	30.00	20.00
				M104B	Architect's Handbook/Three Binders <i>Only</i>	15.00	10.00
				Miscellaneous			
				4Z100	Handbook Supplement Service (1981) keeps M104 up-to-date	16.00	16.00
				2M101	Glossary of Construction Industry Terms (1970)	1.50	1.25

For further information about interpretation of AIA documents, contact the Documents Office, 626-7440.

Education

Accredited Programs in Architecture

Annual list prepared by the National Architectural Accrediting Board (NAAB), containing those schools that offer accredited first professional degree programs, with addresses, phone numbers and names of deans. Free.

Available through *National Architectural Accrediting Board at AIA Headquarters* (783-2007).

ACSA News

Newsletter issued seven times during the academic year, containing news about architectural schools. Available only by membership. Price: \$14 for students; \$23 for all others. Membership includes "Journal of Architectural Education."

Available through *Association of Collegiate Schools of Architecture at AIA Headquarters* (785-2324).

AIA Scholarship Announcement

Annual poster outlining program descriptions, eligibility criteria and application procedures for five AIA scholarship programs. Free.

Available through *Education Office* (626-7349).

Architectural Career Awareness Package (3-M401)

80 color slides with script for use by high school counselors or architects lecturing young groups of prospective architects. Includes "Architecture Schools in North America" and assorted pamphlets. \$27/\$30.

Available through *Association of Student Chapters/AIA at AIA Headquarters* (626-7472) or *Publications Fulfillment Office* (626-7332).

Architectural Schools in North America (3-M124)

Guide (1979) to all professional architecture programs in U.S. and Canada. Complete information on faculty, price, program, entrance requirements, etc. Includes introductory essays on architectural education, directory of foreign schools, joint degree programs and other information. \$8.25/\$8.95.

Available through *Association of Collegiate Schools of Architecture at AIA Headquarters* (785-2324) or *Publications Fulfillment Office* (626-7332).

Architectural Secretaries Association

Organized to promote and advance the professional and educational standards of architectural secretaries and contribute to

the improvement of administrative procedures in architectural offices, ASA has chapters, locally sponsored by AIA chapters, all across the country.

Contact *ASA/AIA Liaison*, 626-7377, or *AIA chapter nearest you*.

ASC/AIA News

Monthly newsletter of the Association of Student Chapters/AIA with news items of interest to architectural students. Free to ASC/AIA members and ASC/AIA affiliate members.

Available through *Association of Student Chapters/AIA at AIA Headquarters* (626-7472).

ASC/AIA Student Forum

Annual convention held over the Thanksgiving holidays that brings together architectural students from around the country. Forum '81 will be held in Los Angeles.

Contact *Association of Student Chapters/AIA at AIA Headquarters*, 626-7472.

Counseling for Architectural Careers

Students desiring basic architectural career information are counseled by the education and professional development department staff. Counseling may be in person or by letter.

Contact *Education Office*, 626-7349.

CRIT—The Architectural Student Journal

Biannual magazine published by the Association of Student Chapters/AIA. Each issue explores a theme of current concern in the field of architecture—such as alternative careers in architecture, architectural education and the architect and the public. Free to ASC/AIA members. Two-year subscription is \$6.

Available through *Association of Student Chapters/AIA at AIA Headquarters* (626-7472).

Design Disciplines: An Overview of Official Practice

A series of seminars produced and sponsored by the Architectural Secretaries Association to introduce the new architectural secretary and/or recent architectural graduate to the administrative functions of an architectural practice.

Contact *AIA/ASA Liaison*, 626-7377.

How to Conduct Environmental Education Workshops for Teachers and Architects (4-N205)

116-page guidebook documents and evaluates five workshops held to help train architects to function as resource people for built environmental education. \$2.

Available through *Publications Fulfillment Office* (626-7332).

Intern-Architect Development Program (IDP)

Cassette and slides of an in-depth review of IDP concepts, participation and operation, including the AIA supplementary

education program and advisory system. 20 minutes. Free loan to AIA members/components.

Available through *Professional Development Office* (626-7354).

Journal of Architectural Education

Quarterly (during academic year) journal of the Association of Collegiate Schools of Architecture (ASCA). Single issue \$4; free to ACSA members; \$12 per year to all others.

Available through *Association of Collegiate Schools of Architecture at AIA Headquarters* (785-2324).

Legal Study Program

Selected architect/law students may receive academic credit for a part-time work-study program concerned with legal matters and contract documents.

Contact *Documents Office*, 626-7440.

Proceedings of ACSA Annual Meeting

Yearly publication of papers from annual meeting workshops, exploring a wide range of topics by architectural faculty from U.S., Canada and abroad. Focus of 1980 proceedings: The Linguistic Analogy in Architecture. Paper, \$25.

Available through *Association of Collegiate Schools of Architecture at AIA* (785-2324).

A Program for Architectural Technicians' Training (6-N203)

18-page publication (1968) prepared by the AIA educational task force for architectural technicians' training, which makes recommendations for the establishment and improving of programs for architectural technicians. Free.

Available through *Education Office* (626-7349).

Reynolds Aluminum Prize for Architectural Students

Brochure (1976) describing the annual award program open to students who have completed two years of architectural school. Sponsored by Reynolds Metals Co. and administered by AIA. Contains eligibility requirements, submission procedures, entry dates, etc., and a tear-off entry slip. Free.

Available through *Awards Division, Office of Assistant Secretary* (626-7390).

Student Competitions

Several competitions held throughout the year.

For current information contact the *Association of Student Chapters/AIA at AIA Headquarters*, 626-7472.

Summer Legal Intern

An architect/law student is selected each year to spend the summer working at AIA headquarters on contract documents and legal concerns.

Contact Documents Office, 626-7440.

For further information about education of architects in general, contact the Education and Professional Development Office, 626-7347. Questions regarding careers and scholarship opportunities should be directed to the Education Office, 626-7349. Contact the Association of Student Chapters/AIA, 626-7472, and the Association of Collegiate Schools of Architecture, 785-2324 (both of which are located at AIA Headquarters) for information about their respective organizations.

Educational Facilities

A Child Went Forth

Color film, 28 minutes, 16mm, focusing on the debilitating effects of the inner-city schools on children, and providing a contrast with new innovative projects for school architecture. Free loan.

Available through Audiovisual Department, Library (626-7495).

For further information about educational facility planning, contact the Professional Interest Programs Office, 626-7364.

Energy

Basics of Solar Heating and Hot Water Systems (2-M262)

48-page publication (1977) from AIA Research Corporation discusses passive and active systems that can be used in residential heating and domestic hot water systems. Introduces systems design considerations, from collector components and placement, to storage and heat exchangers, to distribution. Includes visual "state-of-the-art" view of solar energy systems in housing. \$4.75/\$6.

Available through Publications Fulfillment Office (626-7332).

Developing an Energy Performance Work Plan for Arizona Buildings, edited by Hugh Knoell, AIA

Report of \$52,000-grant program on developing performance-based criteria for

energy conservation in buildings. All items postpaid.

Synthesis, Phase 1 \$7

Appendix A: Climate Charts \$7

Appendix B: Evaluation

Procedures \$7

Appendix C: Implementation

Issues \$7

Available from Arizona Architects Foundation, Inc., 1108 W. Washington, Phoenix, Ariz. 85007.

Dun's Review Reprint (4-N8360Q)

"Constructing the Cost-Effective Facility: Corporate Options in the '80s" from January 1981 issue. This article focusing on energy conscious design is an appropriate handout for corporate groups or clients. Single copy free. \$6 per 10 copies.

Available through Public Relations Department (626-7460) or the Publications Fulfillment Office (626-7332).

Energy and the Built Environment: A Gap in Current Strategies (6-N901)

Publication (1974) prepared by Leo A. Daly, FAIA, and the AIA task force on energy conservation, which shows how sustained efforts to achieve energy efficiency in the built environment can contribute toward solving the energy crisis, and proposes specific programs to bring this about. 18 pages; free.

Available through Publications Fulfillment Office (626-7332).

Energy and the Built Environment: A Gap in Current Strategies—A Nation of Energy Efficient Buildings by 1990 (6-N901; 6-N905)

Two major study reports on energy efficiency. Good reading for background in preparation for speaking, slide show presentation, basis for articles, etc. Free.

Available through Director of Energy Programs (626-7448).

Energy Audits (4-Z203)

Supplement 79-2, August 1979, for the AIA Energy Notebook introduces the concepts, procedures and techniques of effective energy auditing. Energy auditing is a means of identifying energy waste and opportunities for energy conservation in existing buildings. This publication should be studied in conjunction with other available resources such as Energy Planning for Buildings (4-M720), also published by AIA. \$9.

Available through Publications Fulfillment Office (626-7332).

Energy Conservation in Building Design (3-M212)

Prepared by the AIA Research Corporation, it describes opportunities for conserving energy through building design.

It is the product of a national energy policy study financed by the Ford Foundation to investigate various aspects of the

technological and social impacts of energy supply and consumption. Soft cover, 156 pages, \$4.50/\$5.

Available through Publications Fulfillment Office (626-7332).

Energy Efficiency Needn't Cloud Your Life (6-N834)

Brochure of value to homeowners. Free.

Available through Public Relations Department (626-7460) or Publications Fulfillment Office (626-7332).

Energy Planning for Buildings (4-M720)

Presents a proven process that design professionals can use (or adapt) to study the current energy performance of a building, uncover opportunities for energy-conscious improvements, evaluate those opportunities and see that they are carried out to the building owner's best benefit (1979). Describes in detail a manual technique for calculating energy usage and shows in a sample problem how that technique can be applied. Also provides a basis for understanding computer-aided energy estimating techniques. \$40/\$44.

Available through Publications Fulfillment Office (626-7332).

Hold on to Your Heat (and Keep Your Cool) (6-N906)

Pamphlet (1976) intended as a homeowner's guide to energy conservation. Describes how to take advantage of site, envelope, floor plan, windows, insulation, etc., to conserve energy. Includes bibliography. Free.

Available through Publications Fulfillment Office (626-7332) or Public Relations Department (626-7460).

A Line on Design and Energy: Ways to Make it Happen

80 slides and script for use by components for developing visibility programs within their communities to promote the "Line on Design and Energy" theme.

Free loan to components.

Available through Public Relations Department (626-7460).

New Design Concepts for Energy Conserving Buildings (3-M263)

124-page book (1977) describes 115 innovative approaches to designing energy-efficient buildings. From an AIA Research Corporation-sponsored energy-conscious design student competition, held in 1976. Twelve entries of distinction are featured in detail, using the students' drawings and diagrams. Text includes student interviews and jurors' comments. Contains bibliography and design concept index keyed to drawings. \$9/\$9.95.

Available through Publications Fulfillment Office (626-7332).

Prescriptive Standards: No Rx for Energy Conservation in Buildings (6-N816)

Folder (1976) promoting performance-oriented standards for energy conservation, rather than prescriptive standards. Free.

Available through Publications Fulfillment Office (626-7332) or Public Relations Department (626-7460).

A Public Relations Idea Kit: "A Line on Design and Energy"

Explores ways for components to make the most of the design and energy theme at the local level. It contains ideas for component programs and activities—energy fairs, tours, articles, displays, TV and radio spots and more. Free to component executives or PR chairmen.

Available through Public Relations Department (626-7460).

Reaching for the Sun: Program Package 13 (4-N833)

Set of 80 slides and script (1980) illustrating passive solar design principles and their applications through diagrams and representational building samples. Regional and climatic considerations are evident in the examples used. Intended for a nontechnical audience. \$22 prepaid.

Available through Public Relations Department (626-7460) or Publications Fulfillment Office (626-7332).

Sample Speech on Energy

20-minute text, suitable for general audiences, focuses on the economics of the current energy situation and the role that architects can play in the '80s in the design and redesign of our built environment. Single copies free.

Available through Public Relations Department (626-7460).

Sample TV and Radio Public Service Announcements

A "how to" packet on PR planning and effective use of public service announcements. Contains five sample PSAs. Free to component executives and PR chairmen.

Available through Public Relations Department (626-7460).

Saving Energy in the Built Environment: The AIA Policy (6-N904)

Brochure (1975) summarizing two previous publications: "Energy and the Built Environment: A Gap in Current Strategies" and "A Nation of Energy Efficient Buildings by 1990." Free.

Available through Publications Fulfillment Office (626-7332).

The Solar Advantage (6-N820)

Brochure (1978) briefly describing current studies and legislation concerning

solar energy. Results of recent research are applied to the energy efficiency of residences. Free.

Available through Director, Energy Programs (626-7448).

Solar Architecture (3-M234)

350-page book (1979) was prepared for ERDA by the Association of Student Chapters/AIA. Photo-illustrated reference describes the history, components, natural context, research and the future of solar design. A result of the ASC/AIA annual forum held in Tempe, Ariz., November 1975, it is a collection of expert presentations and panel discussions. Attendees included many of the nation's leading architects and researchers in the field. \$10.75/\$12.

Available through Director, Energy Programs (626-7448).

Solar Architecture

70 color slides with booklet. Shows in detail more than 20 existing structures that effectively use the sun's energy. Illustrates buildings with passive solar heating, and buildings with various types of collectors and storage systems. Rent \$15 to AIA members only.

Available through Audiovisual Department, Library (626-7495).

Solar Dwelling Design Concepts (3-M311)

Report (1976) prepared by AIA Research Corporation on solar heating and cooling was prepared under contract to HUD for development as part of HUD's effort to demonstrate the feasibility of solar technology. A short history of solar applications, description of solar components and full systems, discussion of environmental factors and design concepts and case studies make up this comprehensive overview of current concepts in solar design. 146 pages; \$4.50/\$5.

Available through Publications Fulfillment Office (626-7332).

State Energy Conservation Plans: Opportunities for AIA Components

Outlines options for AIA components' involvement in the Department of Energy's program financing supplemental state energy conservation plans and energy audits (1977).

Available through Government Affairs Office (626-7375).

10 Buildings That Save Energy—By Design (4-N835Q)

A new brochure for nonresidential clients. Single copy free. \$25 per 100 copies.

Available through Public Relations Department (626-7460) or Publications Fulfillment Office (626-7332).

10° Below

A light hearted audiovisual presentation prepared for AIA by the Minnesota

Architectural Alliance about energy and the built environment. 191 slides with music and dramatization in a synchronized tape. Two projectors are required. Free loan to AIA Components.

Available through Audiovisual Department, Library (626-7495).

Three Articles on Energy

Suitable for placing with your local media. Free to components.

Available through Public Relations Department (626-7460).

Wind Energy Poster (4-M233)

Front side illustrates the history of wind-harnessing devices for mechanical and electrical power from pre-Christian times to the present. Back side gives a comprehensive account of technical design information for modern wind energy conversion systems, and a list of manufacturers, research organizations and literature references. Includes a summary in French and German. Developed by Vonier and Wolff. Four-color, 24-30 inches. \$4.

Available through Publications Fulfillment Office (626-7332).

For further information about energy, contact the Energy Office, 626-7448.

Environmental Design

The AIA Asks: Why? Why Not?:**Program Package 1** (6-N807)

25-page package (1974) that explains how to place a series of pictures and captions about good and bad environmental features in local newspapers. Describes the program, gives ideas for pictures and captions, provides "how-to" information about approaching the newspaper, etc. Free.

Available through Publications Fulfillment Office (626-7332) or Public Relations Department (626-7460).

Architecture and Your Life (4-Q101)

Color filmstrip, with teachers guide. Deals with the effect of architecture on man and the unprecedented responsibility of today's citizen for deciding upon the quality of the environment. 35mm; 50 frames; \$12.

Available through Publications Fulfillment Office (626-7332).

Design Review Boards: A Handbook for Communities (2-M203)

Résumé (1974) of the law on design review and an annotated model ordinance to guide communities that choose to adopt a design review board process. Pub-

lished by AIA. 52 pages; \$5.75/\$7. Available through Publications Fulfillment Office (626-7332).

Designscape

Color slides with reel-to-reel synchronized tape (1975). A view of many of the old and new "designs" we see all around us. 160 slides; free loan to AIA members only.

Available through Audiovisual Department, Library (626-7495).

Environmental Impact Statements Bibliography

Four-page selected and annotated bibliography (1975) prepared by the AIA committee on architecture for commerce and industry. Free.

Available through Library (626-7493).

Environments for People: Program Package 5 (4-N812)

80 slides, introduction, script and suggestions for use (1976). Explains how architects provide for basic human needs (shelter, privacy, personalization, socializing, mobility, communication) in their design of the man-made environment. \$20.

Available through Publications Fulfillment Office (626-7332) or Public Relations Department (626-7460).

Handbook of Architectural Design Competition (6-J500)

AIA's detailed advice regarding the proper conduct of design competitions. Free.

Available through Design Department (626-7363) or Publications Fulfillment Office (626-7332).

Life Experiences in Environmental Design (4-M127)

Interviews with students and recent graduates about their aspirations, travails, satisfactions, etc. Published by Association of Collegiate Schools of Architecture. 267 pages; \$4.

Available through ACSA (785-2324).

Orchids and Onions: Program Package 4 (6-N811)

Folder (1975) explaining how components can carry on a program that asks the public to nominate organizations and individuals who made good or bad contributions to the man-made environment; a jury selects the winners. Based on a project of the Western Communities Architects' Association, a section of the Chicago Chapter/AIA. Free.

Available to components through Publications Fulfillment Office (626-7332) or Public Relations Department (626-7460).

Spaces for the Species

Slide synchronized cassette tape presentation (1975) summarizing users' responses to various environments, such as a hotel, a school, an urban plaza and a shopping center. 30 minutes; free loan to AIA members only.

Available through Audiovisual Department (626-7495).

For further information about environmental design in general, contact the Design & Environment Programs Office, 626-7363.

Environmental Education

Built Environment Education:

Program Package 10 (6-N824)

Folder highlighting a built environment education program for elementary school students developed and implemented by an architect. Includes a step-by-step sample program outline, plus a guide to resources and information on built environment education. Free to components.

Available through Publications Fulfillment Office (626-7332) or Public Relations Department (626-7460).

Environmental Education: Architecture's Role

Statement of the Institute's policy and initiatives in the area of environmental education. Includes discussion of 1970 Environmental Education Act, program examples and implementation suggestions. Companion publication to Environmental Education Legislation/Regulation. 23 pages; free.

Available through Director, Environmental Education (626-7573) and Government Affairs (626-7375).

Environmental Education Legislation/Regulation: A Strategy Guide for AIA Components

Prepared by the environmental education committee to guide components in helping establish state legislation advancing environmental education. Includes model legislation. Companion publication to Environmental Education: Architecture's Role. 45 pages; free.

Available through Director, Environmental Education (626-7573) and Government Affairs (626-7375).

Environmental Education Teaching Tools (6-N205-3)

40-page annotated catalog prepared by the environmental education committee, listing information on resources (books, games, films, etc.) for environmental education. Free.

Available through Director, Environmental Education (626-7573).

How to Conduct Environmental Education Workshops for Teachers and Architects (4-N205)

Guidebook documents and evaluates five workshops held to help train architects to function as resource people for built environmental education. 116 pages; \$2. Available through Publications Fulfillment Office (626-7332).

Streets (1976)

Curriculum for urban awareness program, grades 3-6, with a teacher's guide. Published through a grant from National Education Association and with the work of the Environmental Education Fund of the BSA. The manuals were prepared by The Architects Collaborative.

Available through Boston Society of Architects, 320 Newbury St., Boston, Mass. 02115, (617) 267-5175.

A Teacher Introduction to Environmental Education (6-N205-2)

31-page booklet prepared by the AIA environmental education committee, intended to arouse interest about the built environment among teachers, with suggestions for classroom activities. Free. Available through Director, Environmental Education (626-7573).

Ethics

AIA Ethical Guidelines (6-J400)

Explains the principles which serve as voluntary guidelines for the professional conduct of members of AIA.

Available through Office of Assistant Secretary (626-7502) or Publications Fulfillment Office (626-7332).

For further information about ethical matters, contact the Office of Assistant Secretary, 626-7502.

Exhibits

An Act of Optimism: Building the Washington Cathedral

Illustrated Octagon exhibition catalog documenting the construction history of the Washington (D.C.) cathedral. Contains exhibition checklist and glossary of terms. 15 pages; \$1.25.

Available through the Octagon, 1799 New York Ave. N.W., Washington, D.C. 20006 (638-3105).

The Architect As Artist

Octagon exhibition catalog containing, one color and eight black and white illustrations. Seven-page checklist of 26 par-

participating architects and titles of art work given to the AIA Foundation. \$2.50.
Available through the Octagon, 1799 New York Ave. N.W., Washington, D.C. 20006 (638-3105).

Architectural Exhibitions

Informative listing (1979, fourth edition) of sources of traveling architectural exhibitions for use by museums, galleries, schools, AIA chapters and public exhibition halls. Prepared by Kym Rice. \$1.
Available through the Octagon, 1799 New York Ave. N.W., Washington, D.C. 20006 (638-3105).

Architectural Fantasies: Creative Alternatives

13-page illustrated Octagon exhibition catalog featuring fantasies by Claes Oldenburg, David Macaulay, SITE Projects and seven additional architects. \$2.50.

Available through the Octagon, 1799 New York Ave. N.W., Washington, D.C. 20006 (638-3105).

Capital Losses

Illustrated checklist (1979), which accompanied exhibition on notable Washington, D.C., buildings destroyed since the 19th century. \$1.

Available through the Octagon, 1799 New York Ave. N.W., Washington, D.C. 20006 (638-3105).

A Celebration of Diversity: Planning the International Center

Illustrated exhibition catalog (1979) on five of the 14 chanceries to be located on a 32-acre site in Northwest Washington, D.C. Architectural firms represented include Skidmore, Owings & Merrill, The Architects Collaborative and the Georgetown Design Group. \$1.50.

Available through the Octagon, 1799 New York Ave. N.W., Washington, D.C. 20006 (638-3105).

Competition 1792: Designing a Nation's Capitol

Catalog from Octagon exhibition on history of the 1792 competition for the U.S. Capitol. Catalog contains extensive information and illustrations on all the competitors. \$3.75.

Available through the Octagon, 1799 New York Ave. N.W., Washington, D.C. 20006 (638-3105).

Dolley and the 'Great Little Madison'

Illustrated exhibition catalog (1977) tracing the celebrated partnership of James and Dolley Madison, concentrating on their impact on American social development \$6.

Available through the Octagon, 1799 New York Ave. N.W., Washington, D.C. 20006 (638-3105).

Just for Fun!

Illustrated catalog (1979) from the Octagon's publicized exhibition on the history and development of architectural toys from the 18th century to the present. Limited supply. \$4.50.

Available through the Octagon, 1799 New York Ave. N.W., Washington, D.C. 20006 (638-3105).

National, Regional and Local Exhibitions

The board of directors may grant approval to AIA members to participate in national exhibitions when the board finds that all such interests are fully protected and when certain conditions are met. The secretary of the Institute or state or regional components has authority to approve local and regional exhibitions.

For further information, contact Office of Assistant Secretary, 626-7502.

"That Red Head Gal": Fashions and Designs of Gordon Conway 1916-1936

Octagon exhibition catalog of photographs, theatrical costumes, fashion designs and movie stills from the archives of Gordon Conway. \$8.50.

Available through the Octagon, 1799 New York Ave. N.W., Washington, D.C. 20006 (638-3105).

Two on Two at the Octagon

Exhibition catalog (1979) paying tribute to Chloethiel Smith, FAIA; Anne Tyng, FAIA; Ada Louise Huxtable, Hon. AIA, and Sarah Booth Conroy, Hon. AIA, and their impact on the urban environment. \$3.

Available through the Octagon, 1799 New York Ave. N.W., Washington, D.C. 20006 (638-3105).

Financial Management

The AIA Firm Survey

Report on various aspects of employment and compensation in AIA firms. Issued periodically. Free.

Available through Executive Office (626-7310).

Architect/Engineer Supplement to Compensation Guidelines (2-M188A)

Available only to architects and engineers, this is intended for in-house use when using cost-based approach to compensation. A discussion of issues that arise when negotiating with the client, it begins with a series of general considerations and deals with the subjects of adjustments and revisions to compensation, contingencies, methods of compensation and billing. 12 pages. \$2/\$2.50.

Available through Publications Fulfillment Office (626-7332).

Compensation Guidelines for Architectural and Engineering Services, Second Edition Revised (2-M188)

Prepared by AIA with the assistance of the American Consulting Engineers Council, this 160-page (1981) financial management tool places equal emphasis on both the architectural and engineering services required for building projects.

Provides a rational process for relating design professionals' compensation to cost of services. Shows how to work with the client to analyze a project, item by item, to reach an agreement on scope of services required. \$12/\$15.

Available through Publications Fulfillment Office (626-7332).

Financial Management for Architects (2-M724)

The "umbrella" of the AIA financial management system, this book covers basic theories and applications appropriate to all size firms of design professionals. Examines financial goals, profit planning, interrelationships of accounting reports and financial controls and the broad view of firm finances. \$22/\$27.50.

Available through Publications Fulfillment Office (626-7332).

Standardized Accounting for Architects (2-M705)

First published in 1950, this extensively revised manual (1978) brings the accounting system presented into conformity with the entire AIA financial management system. It is designed to provide a simple record-keeping procedure that will yield appropriate financial data for routine tax and accounting purposes and for monitoring the operations of a firm. The double-entry system of bookkeeping employed in this book allows the use of either the cash basis or the accrual basis for accounting. Subjects covered include: basic accounting principles, standardized accounting procedures, the basic system and the cash journals, adjusting and closing cash journals, and payroll and project expense accounting. A glossary of terms is provided. \$16/\$20.

Available through Publications Fulfillment Office (626-7332).

For further information about financial management in general, contact the Practice Office, 626-7454. AIA accounting and financial management forms are listed under AIA Documents.

Firesafety

Educating the Architect: Fire and Life Safety

33-page report (1975) prepared by the AIA task group on fire and life safety, documenting the need for better firesafety curricula in education, and a program to implement the proposed recommendations. Free.

Available through Codes and Standards Office (626-7456).

For further information about firesafety, contact the Codes and Standards Office, 626-7456.

Funding

Funding Sources for Architectural Programs: Foundations Supporting the Built Environment (4-M719)

A resource listing compiled by the AIA Foundation and the National Endowment for the Arts. Contains essential information on more than 200 foundations that support the built environment. \$5.

Available through Publications Fulfillment Office (626-7332).

Government Affairs— National

AIA Legislative Program

Annual one-page list containing an abbreviated description of AIA legislative priorities for the 97th Congress. Free.

Available through Government Affairs Department (626-7375).

AIA Political Action Committee (PAC)

Brochure describing why the AIA Political Action Committee was formed and how AIA members can participate. Free.

Architect/Engineer Licensing: Enforcement Case Law

AIA report on case law associated with suspension and revocation of architect and engineer licenses by state registration boards (1981). Free.

Available through Government Affairs Office (626-7375).

Architect/Engineer Licensing: Legal Distinctions

AIA report discussing case law concerning overlap of architectural and engineering services (1981). Free.

Available through Government Affairs Office (626-7375).

Architect Engineer Selection: The American Bar Association Code for State and Local Governments

A case study containing the A/E selection section of the ABA code and a brief description of A/E selection (1981). Free.

Available through Government Affairs Office (626-7375).

Architect Selection: Legislative Guidelines for Public Construction

55-page publication (revised 1977) that contains two model bills for A/E selection for public construction projects and copies of state A/E selection laws. Free.

Available through Government Affairs Office (626-7375).

Architects in Government Roster (2-M161)

List (1980) giving names and addresses of architects employed by federal, state and local governments. \$5/\$6.

Available through Publications Fulfillment Office (626-7332).

Congress of the United States

Brochure containing names and party affiliations of representatives and senators. Arranged by state or territory. Free.

Available through Government Affairs Office (626-7375).

Congressional Contact System

Service to any AIA member who wishes to visit his/her representatives and senators. Information on pertinent legislative issues, a member's committee assignments, AIA policies, etc., are offered on request.

Contact Government Affairs Office, 626-7375.

Legislative Minuteman Program

Nationwide system used by the Institute to communicate with individual members of Congress through practicing architects in their home states who personally know representatives or senators or who are simply willing to contact them on issues of importance to the profession.

Contact Government Affairs Office, 626-7375.

Legislative Minuteman Program Flyer

Biennial flyer describing the program. Includes registration card. Lists some of the accomplishments of the program. Free.

Available through Government Affairs Office (626-7375).

Working in Government: A Profile Study of the Architect as a Public Employee (2-M712)

Prepared by the AIA architects in government committee (1978), the information presented in this report is intended to give the general public a better understanding of the various functions performed by architects in government; to give educators a clearer view of educational needs and opportunities, and government administrators an opportunity to make comparative assessments of architects in various agencies and at various levels of government. Developed from a survey of more than 2,000 architects in government conducted in 1976, it provides a comprehensive profile of those persons practicing as architects in the public sector. \$5/\$6.

Available through Publications Fulfillment Office (626-7332).

Government Affairs— State & Local

AIA Index to Registration Law Resources

Listing of registration law studies, surveys, bibliographies and reports that are available upon request to AIA components (1981). Free.

Available through Government Affairs Office (626-7375).

Architect/Engineer Government Contracting: A Manual (4-M718)

In loose-leaf format, this manual (1979) contains forms, documents, regulations, laws, guidelines and techniques used by public officials and design practitioners in A/E contracting. Prepared by the Committee on Federal Procurement of A/E Services (COFPAES), it is available for the first time outside the successful contracting course. \$95.

Available through Publications Fulfillment Office (626-7332).

Architects in Government Roster (2-M161)

List (1980) giving names and addresses of architects employed by federal, state and local governments. \$5/\$6.

Available through Publications Fulfillment Office (626-7332).

Architects in the Legislature: Increasing Your Visibility

A case study on how to effectively com-

municate architectural concerns to the legislature (1979). Free.

Available through Government Affairs Office (626-7375).

Architects at the Legislature: Lobbying for a Statute of Limitations

Case studies reflecting both successful and unsuccessful lobbying efforts by AIA components and related organizations in Missouri, Minnesota and Illinois.

Available through Government Affairs Office (626-7375)

Architectural Licensing: Legislative Options

A component guide containing discussions of public regulation, types of licensing laws and key provisions contained in most licensing laws (1981). Free.

Available through Government Affairs Office (626-7375).

Architectural Registration: The Examination Issue

An AIA report discussing NCARB registration examinations, the NCARB practice analysis and test validation project and status of examination revision projects in several states (1980). Free.

Available through Government Affairs Office (626-7375).

Coastal Zone Management: A Strategy Guide for AIA Components

This publication describes the Coastal Zone Management Program and its history, and outlines key issues of the program and ways that architects can help in their resolution (December 1978). Free.

Available through Government Affairs Office (626-7375).

Coastal Zone Management: Balancing Protection and Growth

A document for public officials on the Coastal Zone Management Program of loans and grants for planning, management and preservation of the coastlines, and how architects can help state and local governments in implementing such a program (December 1978). Free.

Available through Government Affairs Office (626-7375).

Community Development Block Grants: Opportunities for Shaping Urban Growth

Identifies for local government officials and concerned citizens those provisions of Title I that provide opportunities for implementing AIA's principal urban growth policy recommendations and how architects can participate. Free.

Available through Government Affairs Office (626-7375).

Compendium: Architect Selection Laws (4-N509)

Contains laws of 18 states that now have specific legislation regulating the selection of architects for public construction projects. Appendix contains a list of state agencies responsible for implementing these laws and the federal A/E procurement (Brooks) law. Free to AIA members; \$5, nonmembers.

Available through Publications Fulfillment Office (626-7332).

Compendium: State Statutes of Limitations (4-N510)

Compilation of the state statutes of limitations relating to design professionals and the construction industry. Free to AIA members; \$5, nonmembers.

Available through Publications Fulfillment Office (626-7332).

Designer Registration Overview

AIA report containing description of registration efforts of various designer groups, including interior designers, residential designers and others (1980). Free.

Available through Government Affairs Office (626-7375).

Direct Government Affairs Assistance

Direct assistance to components in the form of on-site consultation and resource documents for those seeking to expand established government affairs activities or focus on individual issues. Consultation by component officers and executives and Institute staff.

Contact Government Affairs Office, 626-7375.

Environmental Education: Architecture's Role

23-page publication discusses the role of architecture in environmental education, describes federal and state legislation and programs, and provides suggestions for implementing environmental education programs.

Available through Government Affairs Office (626-7375).

Environmental Education Legislation/Regulation: A Strategy Guide for AIA Components

Publication prepared by the environmental education committee guide components in helping establish legislation advancing environmental education. Includes model state legislation. Companion publication to *Environmental Education: Architecture's Role*. 45 pages; free.

Available through Government Affairs Office (626-7375).

Forum on Public Architecture: A Conference for Government Administrators—A Resource Book

Collection (1976) of articles on public architecture, presenting significant state and local activity in such areas as energy conservation, land use and adaptive use. 142 pages; free.

Available through Government Affairs Office (626-7375).

Government Alert for Components

Bulletin published six times a year containing brief, timely reports on government affairs developments at the state and local level. Free.

Available through Government Affairs Office (626-7375).

Governmental Information Clearinghouse

A service to provide components with information on state and local issues of professional and public concern. Materials available include copies of legislation, administrative rules, government studies and reports, AIA documents and other background materials. Includes data on liability, energy, registration, etc. *Contact Government Affairs Office, 626-7375.*

How to Organize an Effective Government Affairs Program

Guide (1975) for improving component government affairs programs. Includes information on the purpose and structure of such programs, the legislative process and state governmental contact systems. 40 pages; free.

Available through Government Affairs Office (626-7375).

How To Work Effectively with State Legislatures

Publication (1969) by the American Society of Association Executives, advising associations on establishment of a legislative program, lobbying, campaigning and evaluating a legislative session. 44 pages; free.

Available through Government Affairs Office (626-7375).

Innovations in State Legislation: Land Use Management

Environment and Land-Use: Two California Experiments

Two publications (1973 and 1975) by Richard N. Tager, offered as one unit. The first is an overview of the role states

Go

can play in implementing the fundamental recommendations of the AIA national policy task force. The second report discusses the background and fundamental provisions of CEQA and the Coastal Zone Act. Free.

Available through Design and Environment Programs Office (626-7363).

Involving Architects in the Community Development Block Grants Programs: A Strategy Guide for AIA Components.

For components' use, providing guidance in the CD block grant planning and application process to encourage local AIA involvement in the programs. Free.

Available through Government Affairs Office (626-7375).

Legislative and Government Affairs: Making Your Efforts Count

A checklist compiled by the Minnesota Society/AIA to serve as a tool for evaluating components' government affairs programs (1980). Free.

Available through Government Affairs Office (626-7375).

Lien Laws for Design Professionals: A Survey and Analysis (4-N511)

Study (1980) of lien laws in each state and their applicability to architects and engineers as well as related court rulings. Free to AIA members; \$5, nonmembers. *Available through Publications Fulfillment Office (626-7332).*

Original State and Local Government Programs Documents—Legislative Guidelines and Strategies

These documents may include model legislation, legislative guidelines, background information and strategies for component action on significant governmental issues. *Contact Government Affairs Office, 626-7375.*

Political Action: A Strategy Guide for AIA Components

Document written to encourage architect involvement in the political process, as individuals and through components. Information is included on political action committees, "Meet the Candidates Nights" and calendars for state and local elections. 32 pages.

Available through Government Affairs Office (626-7375).

Political Action Committees for Architects: A Practical Guide

Contains "how to" information on establishing and running an architects' political action committee. Includes tips on fundraising and selecting candidates to support (1981). Free.

Available through Government Affairs Office (626-7375).

Professional Development Requirements for License Maintenance: A Strategy Guide for AIA Components

An AIA component guide dealing with legislation and regulations, policy and strategies related to architect license renewal requirements, including mandatory continuing education (revised 1981). Free.

Available through Government Affairs Office (626-7375).

Registration Law Policy Statements

AIA board-approved policy statements developed by the AIA registration law advisory task force covering a wide range of registration related policies (1980). Free.

Available through Government Affairs Office (626-7375).

Revising Architectural Registration Laws: Strategy Consideration

Contains a 1975 survey report on the issues and political processes concerning architectural registration laws, including strategies for legislative action (1976). Free.

Available through Government Affairs Office (626-7375).

Special Obligations: Issues in the Administration of Public Architecture

A summary of conference presentations and discussions between state and local government administrators concerning constraints and opportunities in public architecture. Free.

Available through Government Affairs Office (626-7375).

State Energy Conservation Plans: Opportunities for AIA Components

Outlines options for AIA components' involvement in the Department of Energy's program financing supplemental state energy conservation plans and energy audits (1977). Free.

Available through Government Affairs Office (626-7375).

State Government Seminar

A forum, held each year at the AIA convention, for state component leaders on issues and strategies for effective lobbying on state government issues.

Contact Government Affairs Office, 626-7375.

State/Local Government: Issues & Strategies (6-N508)

Reference notebook (1979) for AIA components and architects working on government affairs issues. Revised annually, it contains sections on major issues, strategies, case studies and space for component materials. Free to AIA members only.

Available through Government Affairs Office (626-7375).

Sunset Laws: A Strategy Guide for AIA Components

Discussion of the pros and cons of sunset legislation, recommended elements of an effective sunset law and possible component activities during sunset reviews of architectural registration boards and other agencies (1978). Free.

Available through Government Affairs Office (626-7375).

Sunset Overview: Architectural Registration Boards

Description of sunset review experiences of 19 architectural registration boards and procedures to be followed in other states with sunset laws in effect (1980). Free.

Available through Government Affairs Office (626-7375).

What Is Your Stake in Government Affairs?

Pamphlet designed to encourage political action by AIA members. Free. Available in quantities.

Available through Government Affairs Office (626-7375).

For further information about state government affairs activities, contact Government Affairs Office, 626-7375.

Guidebooks

AIA Guide to New York City,

Revised edition. (3-M383)

A street-by-street guide to the city's buildings of historic and architectural interest, shows, theaters, parks and squares.

\$11.75/\$12.95.

Available through New York Chapter/AIA, 457 Madison Ave., New York, N.Y. 10022, (212) 759-5485 (add \$2.75 for postage and handling).

AIA Guide to the Architecture of Washington, D.C. (3-M269)

Convention guidebook (1974) prepared by the Washington Metropolitan Chapter/AIA, on the architecture of Washington, D.C. 246 pages; \$6.25/\$6.95.

Available through Publications Fulfillment Office (626-7332).

Architecture Boston

A guide to the architecture of Boston with a foreword by Walter Muir Whitehill; text by Joseph Eldredge, FAIA (1976). \$6.95 plus \$1.50 postage and handling.

Available through Boston Society of Architects, 320 Newbury St., Boston, Mass. 02115, (617) 267-5175.

Austin and Its Architecture

A portrait of Austin. Hardback, with 485 photographs, hundreds of little-known facts, buildings, places, trees—the whole town in words, maps and pictures. \$10.75/\$12.75.

Available through *Austin Chapter/AIA*, 709 W. 15th Street, Austin, Tex. 78701 (512) 477-3318 or *Texas Society of Architects/AIA*, 2121 Austin National Bank Tower, Austin, Tex. 78701, (512) 478-7386.

Building Art in St. Louis

A guide to over 400 buildings in St. Louis with date, design, architect and pictures. 200 pages. \$11.95 postpaid.

Available through *St. Louis Chapter/AIA*, 919 Olive St., St. Louis, Mo. 63101, (314) 621-3484.

A Bus Tour of Minneapolis Architecture

The Minnesota Society/AIA historic resources committee created a tour map of 26 sites along one of Minneapolis' primary bus routes from the University of Minnesota to the Southdale Shopping Center, highlighting both historic and contemporary sites. Free to AIA components, \$1 handling to others.

Available through *Minnesota Society/AIA*, 314 Clifton Ave., Minneapolis, Minn. 55403, (612) 874-8771.

Detroit Architecture

Guide (1980) to the architecture of Detroit \$7.

Available through the *Detroit Chapter/AIA*, 553 E. Jefferson Ave., Detroit, Mich. 48226, (313) 965-4100.

Historic Wisconsin Architecture

A guidebook (revised edition, 1976) to historic buildings in Wisconsin, containing sections on Frank Lloyd Wright, Louis H. Sullivan, Purcell & Elmslie. Pictures, maps and short descriptions of more than 100 buildings. \$2, plus \$.50 postage and handling.

Available through *Wisconsin Society of Architects/AIA*, 615 E. Washington Ave., Madison, Wis. 53703, (608) 257-8477.

The Houston Coloring Book

A simple alphabetical guide for touring in Houston. The book (1976) depicts buildings, parks and other significant landmarks in and around the city. It is aimed at children, but adults will find it a delightful city souvenir. Free.

Available through *Houston Chapter/AIA*, 3121 Buffalo Speedway, Suite 404, Houston, Tex. 77098, (713) 629-0191.

Indianapolis Architecture

Views of Indianapolis by neighborhoods, including more than 500 photographs, paralleling the development of the city's history. Published by the Indiana Architecture Foundation, it is indeed a third generation guidebook. \$6.95, plus \$1 for handling.

Available through *Indiana Society of Architects/AIA*, 148 N. Delaware St., 46204, (317) 634-3871.

Indianapolis Architecture Guidebook:**Program Package 8 (6-N826)**

A folder (1977) describing the process by which Indianapolis Chapter/AIA published an extensive guidebook of that city. Includes sections on why to write a guidebook, forming a committee, fund-raising, budgeting, selecting printer and designer, and publicizing the project and the product. Free to components.

Available through *Publications Fulfillment Office (626-7332)* or *Public Relations Department (626-7460)*.

Kansas City

A guide to Kansas City's historic and contemporary architecture by neighborhoods. This soft cover, pocket size, book contains 256 pages of black and white photographs of 300 buildings. Published by the Kansas City Chapter/AIA in conjunction with the 1979 "Celebration of Architecture." \$6.95, plus \$1.25 handling.

Available through *Kansas City Chapter/AIA*, 20 W. Ninth St., Kansas City, Mo. 64105, (816) 221-3485.

Victorian Traveler's Companion

Published by the Victorian Society in America, an 114-page illustrated guide to 19th-century house museums, inns, tours and historic sites. \$5.50.

Available through *the Octagon, 1799 New York Ave. N.W., Washington, D.C. 20006 (638-3105)*.

Walking Map of Downtown St. Louis

Shows location of buildings of historical interest. Free. Please send stamped self-addressed envelope. Laclede's landing map and list of architects' Sunday tours also available upon request.

Available through *St. Louis Chapter/AIA*, 919 Olive St., St. Louis, Mo. 63101, (314) 621-3484.

Welcome to Los Angeles: An Architectural Discovery Map. (L.A. Architect, June 1977).

Three-page folded guide to Los Angeles. First section is a map of Los Angeles and Los Angeles County. Numbers on the map correspond to photos in the next section which depict a cross-section of L. A. architecture from 1750 to 1977.

The third section includes a time-line of architectural history in L. A. along with a brief description of each of the build-

ings photographed in the above section. \$1 plus tax and postage.

Available through *Los Angeles Chapter/AIA*, 8687 Melrose Ave., Los Angeles, Calif. 90069, (213) 659-2282.

Westbrook

Booklet with maps, illustrations and drawings which document the history of Westbrook in Surrey, England, home of Gen. James Edward Oglethorpe, founder of Georgia. \$5 plus postage.

Available through *the Georgia Association/AIA*, Peachtree Center/Cain Tower Lobby, 229 Peachtree St., Atlanta, Ga. 30303, (404) 524-3877.

Historic Preservation

Adaptive Re-Use: Extending the Life of Old Buildings (6-N827)

Written by AIA's PR department as an informative piece for the general public (1979), this pamphlet features a description of four honor award-winning buildings that exemplify this important trend in architecture: Boston's Faneuil Hall, San Francisco's Cannery and Ghirardelli Square and Chicago's Navy Pier. Free.

The Architect as a Preservationist (1-HBC21)

Chapter 21 (1971) of the *Architect's Handbook of Professional Practice*, this document includes an introduction to preservation, its elements, basic architectural services, compensation for architectural services and supplementing the standard forms of agreement. \$.60/\$.90. Available through *Publications Fulfillment Office (626-7332)*.

Conserving Architectural Resources

An annotated bibliography published by the committee on historic resources of the Boston Society of Architects, 1978. "... Present(s) a range and selection of publications which will advance the conservation of architectural resources. . . ." Free.

Available through *Boston Society of Architects*, 320 Newbury St., Boston, Mass. 02115, (617) 267-5175.

Directory of Historic American Architectural Firms

Published jointly by AIA Foundation and the Committee for the Preservation of Architectural Records, the directory is an

Hi

alphabetical listing of 102 architectural firms in continuous practice since 1917. The directory includes name changes as well as archival holdings. \$3.

Available through the Octagon, 1799 New York Ave. N.W., Washington, D.C. 20006 (638-3105).

Guide to Historic Preservation (6-N301)
Prepared by the AIA committee on historic resources, this booklet (1978) explains preservation services from the pre-design and research phase through the construction and contract administration phase. It also discusses the preservation team, preservation benefits, costs and selection of an architect. Free.

Available through Publications Fulfillment Office (626-7332).

Guidelines for Preservation, Restoration and Alterations to the Central Library of Los Angeles

Report (1979) by the Los Angeles Chapter/AIA library study team. \$5 plus tax and postage.

Available through the Los Angeles Chapter/AIA, 8687 Melrose Ave., Los Angeles, Calif. 90069, (213) 659-2282.

Our Vanishing Heritage

Why hold on to our past? What is historically valuable? Published by the historic resources committee of the Boston Society of Architects, \$1 postpaid.

Available through Boston Society of Architects, 320 Newbury St., Boston, Mass. 02115, (617) 267-5175.

Restoring a Landmark

Poster showing cross section of the Octagon, Plate XII from Glenn Brown's 1914 monograph. 24x32 inches. \$4.50 postpaid.

Available through the Octagon, 1799 New York Ave. N.W., Washington, D.C. 20006 (638-3105).

Stations

Color film, 16mm, 28 minutes (1974). Shows many of the interesting and innovative uses being made of old railroad stations, in order to preserve these landmarks. Rent \$15 to AIA members only. *Available through Audiovisual Department, Library (626-7495).*

The Texas Historical Preservation Manual

Published in three-hole binder by TSA's historic resources committee, the aim is to aid and educate architects and laymen in the practice of preservation, restoration and adaptive use of older buildings. Includes sections on the history of preservation in Texas, preservation and the law, procedures for obtaining funds for preservation, procedures of the Register of Texas Historical Monuments and of the

National Register of Historic Places, case histories, etc. Designed to be expanded and updated. \$20.

Available through Texas Society of Architects/AIA, 2121 Austin National Bank Tower, Austin, Tex. 78701, (512) 478-7386.

Victorian Traveler's Companion

Published by the Victorian Society in America, an 114-page illustrated guide to 19th-century house museums, inns, tours and historic sites. \$5.50.

Available through the Octagon, 1799 New York Ave. N.W., Washington, D.C. 20006 (638-3105).

William Thornton: A Renaissance Man in the Federal City

Exhibition catalog (1976) for the exhibition held at the Octagon on the 18th century architect of the U.S. Capitol and the Octagon. Prepared by David N. Yerkes, FAIA, and Elinor Stearns. 58 pages; 46 black and white illustrations. \$3.75 postpaid.

Available through the Octagon, 1799 New York Ave. N.W., Washington, D.C. 20006 (638-3105).

For further information about historic preservation in general, contact the Professional Interest Programs Office, 626-7364.

Housing

Homeowner's Reminders

Pamphlet (1978) for public use. Includes tips for homeowners on home security, water problems, saving energy, termites, contracting for home improvement, and on architects. 15 pages; free.

Available through Michigan Society of Architects, 553 E. Jefferson, Detroit, Mich. 48226, (313) 965-4100.

Homes for Better Living Awards

Brochure describing the annual awards program open to custom-designed houses, merchant-built houses and multifamily housing in the U.S. and its possessions. Sponsored by AIA in conjunction with *Housing* magazine. Contains eligibility requirements, submission procedures, entry dates and a tear-off entry slip. Free.

Available through Awards Division, Office of Assistant Secretary (626-7390).

Shelter

100 color slides with booklet. Depicts various shelters from around the world; includes hand-built houses, yurts, domes, tents, cottages, barns and free-form sculptured dwellings. Rent \$15 to AIA members only.

Available through Audiovisual Department, Library (626-7495).

Survey of Southern California Housing (Environmental Communications)

100 color slides with booklet. Illustrates the great variety of housing, including mansions in Beverly Hills, "cliff-hangers" in Hollywood, the ghetto in Watts, beach places in Malibu and apartment buildings and housing throughout the area. Rent \$15 to AIA members only.

Available through Audiovisual Department, Library (626-7495).

Industrial Architecture

Architecture for Commerce and Industry Conference

This first North American Conference on Industrial Architecture will be held Oct. 4-6, 1981 in Detroit. Case studies will illustrate psychological considerations, measurements of quality and future directions in the design of workspaces.

Contact Professional Interest Programs (626-7364).

For further information about industrial architecture in general, contact the Professional Interest Programs Office, 626-7364.

Insurance

Benefit Insurance Programs Commended by AIA

Major medical insurance for firms and individuals, accidental death and dismemberment for individuals, disability income for individuals, hospital confinement for individuals.

Contact Association Administrators and Consultants, Inc., 800-854-0491. In Alaska, California and Hawaii, dial collect 714-833-0673.

Professional liability program.

Contact Victor O. Schinnerer & Co., Inc. 5028 Wisconsin Ave. N.W., Washington, D.C. 20016.

Life insurance for firms and individuals. *The AIA Insurance Trust, 1612 K St. N.W., Washington, D.C. 20006; (202-296-5047).*

Construction Bonds and Insurance Guide second edition (2-M163)

Loose-leaf reference book (1979) prepared by Bernard B. Rothschild, FAIA, containing information on bonds and insurance related to construction projects, with glossary of insurance terms and suggested checklist. \$16/\$20.

Available through Publications Fulfillment Office (626-7332).

Insurance and Bonds of Suretyship
(1-HBC7)

Chapter 7 (1969) of the Architect's Handbook of Professional Practice, this document outlines professional insurance, personnel insurance, office insurance, owner and contractor insurance, bonds of suretyship, prototype letters, certificate of insurance and a checklist on protection. \$1.20/\$1.80.

Available through Publications Fulfillment Office (626-7332).

Professional Liability Insurance Flyer

Brief two-page report on the high points of PLI and a list of the insurance carriers currently selling this insurance. Free.

Available through Practice Division, Liability Program (626-7457).

Professional Liability Insurance Survey

Survey report describing coverages, policy structure and claims network of the seven major liability insurance companies. Free. Available in October through Liability Program Office (626-7457)

Project Liability Insurance Flyers

Two brief folders, prepared by Victor O. Schinnerer & Co., outlining a new concept in professional liability insurance on a per project basis. Free.

Available through Liability Program Office (626-7457).

For further information about liability insurance, contact the Practice Department, 626-7457.

Interiors**Scope of Services of Interior Architecture (AIA Committee on Interior Architecture)**

Color slides (1980) with script describing the array of services architects provide in interior design, relating these services to AIA Document B171, "Standard Form of Agreement for Interior Design Services." 200 slides designed for two projectors and two screens, but can be shown with a single projector and screen. Free loan: AIA members only.

Available through Audiovisual Department, Library (626-7495).

International Relations**Architect's Guide to International Practice** (2-M715)

Produced through the efforts of AIA's federal agency liaison department, this book (1978) comes in response to requests for information about overseas work. The guide contains pertinent facts

on 29 foreign countries, acquainting architects with the complexities and legal/financial considerations for practicing abroad as well as the differences between foreign and domestic markets. It also presents an overview of international practice and discusses the merits of using the services of overseas representatives and establishing an overseas presence with a local firm. \$12/15.

Available through Publications Fulfillment Office (626-7332).

For further information about international relations, contact the International Relations Office, 626-7549.

Joint Ventures**Interprofessional Agreements** (1-HBC10)

Chapter 10 (1975) of the Architect's Handbook of Professional Practice, this document covers working relationships, architect-consultant agreements, architect-engineer agreement forms and joint venture agreements. \$.60/\$.90.

Available through Publications Fulfillment Office (626-7332).

Justice Facilities**Architecture for Justice Conference**

The national committee on architecture for justice will hold its 1981 conference, "Jailhouse Tech," in Toronto, Oct. 1-3. The conference will concentrate on technological innovations in justice facility hardware.

Contact Professional Interest Programs, 626-7364.

Architecture for Justice Exhibit

An annual exhibit, jointly sponsored with the American Correctional Association, of recent facilities for corrections, courts and law enforcement. Information and registration material for the 1982 exhibit will be available in March 1982.

Contact Professional Interest Programs Office, 785-7364.

Architecture for Justice Exhibition Directory

1979 (2M722); 1980 (2M728); 1981 (2M729)

This annual publication contains two-page illustrated descriptions of each project selected for that year's architecture for justice exhibit.

Available through Publications Fulfillment Office (626-7332).

Design Resource File: Planning Justice Facilities (2-M714)

This resource, updated in 1980 by the AIA committee on architecture for jus-

ice, contains: guidelines for the justice planning process; resources and bibliographies pertaining to court facilities, correctional facilities and juvenile justice; an evaluation checklist for law enforcement facilities, and a report on the professional liability considerations in justice facility design. \$10/\$12.50.

Available through Publications Fulfillment Office (626-7332).

For further information about justice facility planning, contact the Professional Interest Programs Office, 626-7364.

Land Use**Coastal Zone Management: Balancing Growth Protection**

Coastal Zone Management: Component Guide. These two booklets assist coastal state components in positive action toward effecting coastal zone management plans with design input in their states. Free.

Available through Government Affairs Office (626-7375).

Innovations in State Legislation: Land Use Management**Environment and Land-Use: Two California Experiments**

Two publications (1973 and 1975) by Richard N. Tager, offered as one unit. The first is an overview of the role states can play in implementing the fundamental recommendations of the AIA national policy task force. The second report discusses the background and fundamental provisions of CEQA and the Coastal Zone Act. Free.

Available through Design and Environment Programs Office (626-7363).

For further information about land use in general, contact the Design and Environment Programs Office, 626-7363.

Legal Concerns**Legal Concerns** (1-HBC19)

Chapter 19 (1969) of the Architect's Handbook of Professional Practice, this document includes information on the law and legal profession, licensing, legal responsibility, professional liability, liability insurance, entering practice, contracts, the contractor and the law, the owner and the law, mechanics liens, arbitration and expert witnesses. \$1.20/\$1.80.

Available through Publications Fulfillment Office (626-7332).

Le

Legal Study Program

Selected architect/law students may receive academic credit for a part-time work-study program concerned with legal matters and contract documents.

Contact Documents Office, 626-7440.

Lien Laws for Design Professionals:

A Survey and Analysis (4-N511)

Study (1980) of lien laws in each state and their applicability to architects and engineers as well as related court rulings. Free to AIA members; \$5, nonmembers. *Available through Publications Fulfillment Office (626-7332).*

Office of General Counsel

The general counsel serves as corporate legal adviser to AIA, its related corporations and to components regarding the corporation bylaws, contracts, antitrust and tax matters and other activities.

Contact Office of General Counsel, 626-7389.

Summer Legal Intern

An architect/law student is selected each year to spend the summer working at AIA headquarters on contract documents and legal concerns.

Contact Documents Office, 626-7440.

For further information about legal concerns in general, contact the Documents Office, 626-7440.

Library

AIA Library Cross-Referenced

Awards File

All AIA honor and merit awards have been indexed by date, place, architect, name of project and building type. The library staff can answer questions such as how many houses in Chicago have won AIA awards, etc.

Contact the Library, 626-7493.

Association of Architectural Librarians Meeting

Held annually in conjunction with the AIA national convention for librarians from schools of architecture, firms and special libraries.

Contact the Library, 626-7493.

Bibliographies of AIA Library Holdings and Periodical Articles

The library staff will prepare on request bibliographies of library books and/or periodical articles on specific subjects or building types. Members can identify books they wish to borrow from these lists. Free. Photocopies 20 cents per page. *Contact the Library, 626-7493.*

Bibliography of Bibliographies

Four-page list (1978) of subject bibliographies compiled by the library staff. Contains over 200 subjects on which bibliographies of the library's holding and/or periodical articles have been prepared. Free.

Available through Library (626-7493).

Biographical Information on Architects

The library will attempt to provide biographical information on individual architects, using reference sources such as the Baldwin Memorial Archive of American Architects.

Contact the Library, 626-7493.

Book Loans

Members may borrow up to six books at one time from the AIA library for a two-week loan period. The only charge for this service is return postage via UPS or insured mail.

Contact the Library, 626-7493.

Library Research Services

The library staff will respond to questions, either in person, by telephone or by letter, on aspects of architecture and construction, architectural history, building types, etc., using the library's cataloged volumes, reference books, indexes and more than 400 current periodicals. Free.

Contact the Library, 626-7493.

Recent Accessions

Bimonthly list of recent library acquisitions, arranged by subject. Free.

Available through the Library (626-7493).

Services to Members

Sheet (1981) describing the AIA library's services to AIA members. Free.

Available through the Library (626-7493).

For further information about the AIA Library, contact the Library directly, 626-7493. Questions regarding audiovisual materials should be directed to the Audiovisual Department, 626-7495.

Marketing

Achieving Results with Words (T104)

This 40-hour, 10-unit program, delivered in two sections, helps develop written communication skills necessary to sell ideas. \$110.

Available through Professional Development Office (626-7355).

Designing Your Brochure as an Aid in Marketing Your Services (3-S224)

This one-hour cassette (1976) tells you how to gear your brochure to your desired market by making it convey your firm's personality, your ability to take care of the client, your problem-solving ability,

the range of your services, etc. The contents of an "ideal" brochure are outlined. \$10/\$12.

Available through Publications Fulfillment Office (626-7332).

Making Effective Presentations (T105)

An eight-step correspondence course dealing with techniques of conducting presentations, client reaction and follow-through. \$85.

Available through Professional Development Office (626-7355).

Marketing Architectural Services (1-HBC-B-8)

Chapter 20 (1980) of the Architect's Handbook of Professional Practice, this document covers current trends, AIA studies, types of comprehensive services, firm organization and operation, owner-architect agreements and the use of the Handbook. \$1.50/\$2.25.

Available through Publications Fulfillment Office (626-7332).

Selling Architectural Services (3-S207)

Cassette (1973) showing how the architect can conduct a practice in a professional and more prosperous manner by using effective marketing techniques. \$10/\$12.

Available through Publications Fulfillment Office (626-7332).

Selling Architectural Services II (3-S218)

This cassette (1975) examines the person-to-person selling process. It focuses on how to understand and work with your client's problem, achieving a mutually beneficial client-architect relationship. \$10/\$12.

Available through Publications Fulfillment Office (626-7332).

Successful Marketing of Architectural Services Game Seminar (T103)

Correspondence course to help firms develop effective marketing programs. Each study group limited to six people. \$85.

Available through Professional Development Office (626-7355).

Successful Selling of Professional Services (T106)

Six-section, learn-by-doing course that teaches through a series of typical case studies how to consistently improve your selling outcomes. \$85.

Available through Professional Development Office (626-7355).

Meetings

AIA National Convention

Annual conference for all AIA members, where officers are elected, product information displayed, workshops and seminars presented, etc. Location and registration fee vary.

Contact *Convention Office*, 626-7395.

Architecture for Commerce and Industry Conference

This first North American Conference on Industrial Architecture will be held Oct. 4-6, 1981 in Detroit. Case studies will illustrate psychological considerations, measurements of quality and future directions in the design of workspaces.

Contact *Professional Interest Programs*, 626-7364.

Architecture for Justice Conference

The national committee on architecture for justice will hold its 1981 conference, "Jailhouse Tech," in Toronto, Oct. 1-3. The conference will concentrate on technological innovations in justice facility hardware.

Contact *Professional Interest Programs*, 626-7364.

ASC/AIA Student Forum

Annual convention held over the Thanksgiving holidays brings together architectural students from around the country. Forum '81 will be held in Los Angeles.

Contact *Association of Student Chapters/AIA*, at *AIA Headquarters*, 626-7472.

Association of Architectural Librarians Meeting

Annual meeting held in conjunction with the AIA national convention, of librarians from schools of architecture, firms and special libraries.

Contact *the Library*, 626-7493.

Federal Programs Conference

Annual conference sponsored by AIA and the engineering societies. Provides opportunities for A/E professionals to meet key government officials from more than 52 federal agencies and the Congress.

Contact *Government Affairs Office*, 626-7375.

Grassroots

An annual conference held each year bringing component officers and executives together with national officers and staff. Purpose is to review and discuss national programs and policies, give component leaders an opportunity to partici-

pate in the national planning process and provide a forum for the exchange of ideas among components.

Contact *Component Services Office*, 626-7377.

1981 Convention Cassettes

Cassette recordings of the theme programs and seminars of the 1981 AIA Convention. Individual tapes \$5 or any set of six \$28, plus postage and handling (\$1 per tape, \$3 maximum).

Architects on Energy: The Shape of Things to Come, 2 parts

Audit & Retrofit, 2 parts

Computers in Practice, 2 parts

Design & Transformation, Ralph Knowles

Earth-sheltered Design, 2 parts

Emerging Technologies, 2 parts

Energy Conservation Awards Case Study, 2 parts

Energy Economics, 2 parts

Energy in Design: Techniques, 6 parts

Financial Management for Architects, 4 parts

Glass, Windows & Energy, 2 parts

History & Technology: The New American Heritage

Lighting & Daylighting, 2 parts

Management of the Energy-conscious

Design Process, 4 parts

Marketing Energy Services, 2 parts

Policy Development & Design, 2 parts

Preservation & Energy, 2 parts

Solar Heating & Cooling, 2 parts

Mail all orders to *Dis-Com Inc.*, *Discovery Communications*, 3585 *Lexington Ave. N.*, *Arden Hills, Minn.* 55112.

Schedule: Regional and State Conventions and Expositions

Annual schedule of meetings to be held by components, including place, expected attendance and contacts. Free.

Available through the *Convention Office* (626-7395).

For further information about meetings in general, contact the *Convention Office*, 626-7395.

Membership

AIA Membership Directory (4-M136)

Annual alphabetical listing of AIA members, including addresses and chapter affiliations. Appendices include honorary members and fellows, component presidents, medals and awards, affiliated and associated organizations. \$15/\$75.

Available through *Publications Fulfillment Office* (626-7332).

Membership Forms/H Series

H301—Application for Membership

H302—Application for Associate Membership

H303—Recommendation of Chapter on Application for Membership

H304—Application for Chapter Transfer

H306—Application for Membership (for use only by present associate members of the AIA)

H307—Application for Membership (for use only by former AIA members)

H341—Application for Student Affiliate Membership

H351—Application for Professional Affiliateship

H601—Application for Membership Emeritus

Available through *Membership Procedures Division*, *Office of Assistant Secretary* (626-7393).

Mini-Grassroots

Program of 45 minutes to 1½ hours, designed to aid components in programming. Gives overview of AIA services and benefits to members and augments local members with national staff. Can be combined with membership recruitment activities. Free.

Contact *Component Services Office*, 626-7376.

For further information about membership procedures, contact the *Membership Records Division*, *Office of Assistant Secretary*, 626-7393. Questions pertaining to *Honorary Membership (Hon. AIA)* should be referred to *Awards Division*, *Office of Assistant Secretary*, 626-7390; to *Honorary Fellowship (Hon. FAIA)*, *Professional Interest Programs Office*, 626-7364. More detailed biographical information on individual architects may be obtained through the *Library*, 626-7493.

For further information about securing new members, contact *Component Affairs Office*, 626-7378.

The Octagon

AIA Foundation Booklet

Booklet (1979) providing information on the AIA Foundation and the Octagon. Free.

Available through the *Octagon*, 1799 *New York Ave. N.W.*, *Washington, D.C.* 20006 (638-3105).

AIA Foundation Poster

Silkscreened and numbered limited edition of 500 posters showing a section of the Octagon's drawing room cornice. \$12.50.

Available through the *Octagon*, 1799 *New York Ave. N.W.*, *Washington, D.C.* 20006 (638-3105).

AIA Headquarters Slide Show

50 color slides, with script and cassette tape (1974). Past AIA President Archibald Rogers, FAIA, discusses the AIA headquarters building and the Octagon. Free loan to AIA members only. Available through *Audiovisual Department, Library* (626-7495).

The Architect As Artist

Octagon exhibition catalog containing one color and eight black and white illustrations. Seven-page checklist of 26 participating architects and titles of art work given to the AIA Foundation. \$2.50. Available through *the Octagon, 1799 New York Ave. N.W., Washington, D.C. 20006* (638-3105).

Architectural Fantasies: Creative Alternatives

13-page illustrated Octagon exhibition catalog featuring fantasies by Claes Oldenburg, David Macaulay, SITE Projects and seven additional architects. \$2.50.

Available through *the Octagon, 1799 New York Ave. N.W., Washington, D.C. 20006* (638-3105).

The Octagon

Brochure containing a brief history of the Octagon, its hours of opening, etc. Free. Available through *the Octagon, 1799 New York Ave. N.W., Washington, D.C. 20006* (638-3105).

The Octagon. Being an Account of a Famous Washington Residence: Its Great Years, Decline and Restoration.

History of the Octagon with index and selected bibliography. Prepared by George McCue, Hon. AIA. 61 illustrations, seven in full color. 106 pages; \$6, postpaid. Send check to *the Octagon, 1799 New York Ave. N.W., Washington, D.C. 20006* (638-3105).

Octagon Slide Set

Five color slides of the Octagon. \$2.50. Available from *the Octagon, 1799 New York Ave. N.W., Washington, D.C. 20006* (638-3105).

For further information about the Octagon, contact the curator, 638-3105.

Office Management

The AIA Handbook (1-HBC1)

Chapter 1 (1973) of the Architect's Handbook of Professional Practice, this document includes general information on the handbook, including the preface, table of contents, general index and information on chapters. \$.60/\$.90.

Available through *Publications Fulfillment Office* (626-7332).

Architect's Handbook of Professional Practice (1-M104)

Three-volume set in ring binders includes samples of all A, B, C, D, E and G documents, plus 18 chapters and a glossary of construction industry terms. \$30/\$45. Contents only (no binders), \$20/\$30 (1-M104A). Three binders (no contents), \$10/\$15 (1-M104B). Individual chapters of the Handbook are listed under **AIA Documents**, and described under the subjects they cover.

Available through *Publications Fulfillment Office* (626-7332).

Architect's Handbook of Professional Practice—Supplement Service (4-Z100)

Subscriptions to the Supplement Service bring the latest editions of the documents contained in the handbook to subscribers. \$16.

Available through *Publications Fulfillment Office* (626-7332).

The Architect's Office (1-HBC/B1)

Document (1980) covers management planning, legal structure, financial management, organization, selection and direction of staff and the personnel policy manual. \$1.50/\$2.25.

Available through *Publications Fulfillment Office* (626-7332).

Architectural Secretaries Association

Organized to promote and advance the professional and educational standards of architectural secretaries and contribute to the improvement of administrative procedures in architectural offices, ASA has chapters, locally sponsored by AIA chapters, all across the country. ASA holds annual meetings in conjunction with the AIA national convention.

Contact *AIA/ASA Liaison*, 626-7377. For information on local chapter meetings, contact *AIA chapter nearest you*.

Current Techniques in Architectural Practice (2-M701)

An overview of the practice of architecture edited by Robert A. Class, AIA, and Robert E. Koehler, Hon. AIA. Published jointly by AIA and Architectural Record Books. 275 pages; \$22/\$27.50.

Available through *Publications Fulfillment Office* (626-7332).

Design Disciplines: An Overview of Office Practice

A series of seminars produced and sponsored by the Architectural Secretaries Association to introduce the new architectural secretary and/or recent architectural graduate to the administrative functions of an architectural practice.

Contact *AIA/ASA Liaison* (626-7377).

Hertz Car Rentals Discount Card

Hertz identification card entitles AIA members, employees and families to a 40 percent discount off the advertised price of any Hertz rental car (excluding tour/touring rates.)

Available through *Controller's Office* (626-7322).

The Management of Time (3-S216)

Cassette explaining how to accomplish more in less time. A guide to organize and use time efficiently and effectively. 45 minutes. \$10/\$12.

Available through *Publications Fulfillment Office* (626-7332).

Setting Up an Architectural Firm (3-S229)

Cassette covering the wide range of considerations in setting and running an architectural firm, including organization, business management, legal considerations, information resources, office machines. 90 minutes. \$10/\$12.

Available through *Publications Fulfillment Office* (626-7332).

Periodicals

ACSA News

Newsletter issued seven times during the academic year, containing news about architectural schools. Available only by membership. Price: \$14 for students; \$23 for all others. Membership includes "Journal of Architectural Education." Available through *Association of Collegiate Schools of Architecture at AIA* (785-2324).

AIA Journal

Official magazine of AIA, published 14 times a year. Subscription price included in AIA membership dues.

For subscription information for others, contact *Circulation Department, AIA Journal*, 626-7327.

AIA Memo

Newsletter, published twice a month, sent to the entire membership. Aims to keep members abreast of Institute programs, achievements, services, etc. Free.

Available through Public Relations Department (626-7460).

ASA Journal

Official publication of the Architectural Secretaries Association. Published three times yearly to provide communication between ASA chapters and articles of interest to the membership.

Contact AIA/ASA Liaison, 626-7377.

ASC/AIA News

Monthly newsletter of the Association of Student Chapters/AIA with items of interest to architectural students. Free to ASC/AIA members and ASC/AIA affiliate members.

Available through Association of Student Chapters/AIA at AIA Headquarters (626-7472).

CRIT—The Architectural Student Journal

Biannual magazine published by the Association of Student Chapters/AIA. Each issue explores a theme of current concern in the field of architecture—such as alternative careers in architecture, architectural education or the architect and the public. Free to ASC/AIA members. Two-year subscription is \$6.

Available through Association of Student Chapters/AIA at AIA Headquarters (626-7472).

Government Alert for Components

Bulletin published six times a year containing brief, timely reports on government affairs developments at the state and local level. Free.

Available through Government Affairs Office (626-7375).

Journal of Architectural Education

Quarterly (during academic year) journal of the Association of Collegiate Schools of Architecture (ACSA). Single issue \$4; free to ACSA members; \$12 per year without membership to all others.

Available through Association of Collegiate Schools of Architecture at AIA Headquarters (785-2324).

Research and Design

Previously published four times a year by the AIA Research Corporation, the publication has been suspended indefinitely. Single copies of past issues are available for \$4. Payments must be received in advance.

Available through AIA Research Corporation (626-7500).

Posters**AIA Foundation Poster**

Silkscreened and numbered limited edition of 500 posters showing a section of the Octagon's drawing room cornice. \$12.50.

Available through the Octagon, 1799 New York Ave. N.W., Washington, D.C. 20006 (638-3105).

Architectural Styles Chart

American architecture examples, 1600 to 1940. 40x30 inches, prepared by Panek. \$8 postpaid.

Available through St. Louis Chapter/AIA, 919 Olive St., St. Louis, Mo. 63101

Fantasy Architecture Exhibition Poster

Silkscreened and numbered limited edition of David Macaulay's drawing of an "inflatable cathedral" from *Great Moments in Architecture*. Signed by the artist. \$12.50.

Available through the Octagon, 1799 New York Ave. N.W., Washington, D.C. 20006 (638-3105).

Historic Rosson House

Poster of Rosson House, Phoenix, Ariz., drawn by Frederick Schweitzer, AIA; black on ivory, 18x24 inches. \$5 postpaid.

Available through Arizona Architects Foundation, Inc., 1121 N. Second St., Phoenix, Ariz. 85004.

Restoring a Landmark

Poster showing cross section of the Octagon, plate XII from Glenn Brown's 1914 monograph. 24x32 inches. \$5.50 postpaid.

Available through the Octagon, 1799 New York Ave. N.W., Washington, D.C. 20006 (638-3105).

St. Louis—Montage of St. Louis Buildings

Black and white print (20x14 inches or 26x18 inches) suitable for framing. \$7 postpaid. Specify large or small size.

Available through St. Louis Chapter/AIA, 919 Olive St., St. Louis, Mo. 63101.

St. Louis World's Fair Panorama Poster

Shows buildings and plan of 1904 fair. 36x14 inches. \$8 postpaid.

Available through St. Louis Chapter/AIA, 919 Olive St., St. Louis, Mo. 63101.

"That Red Head Gal" exhibition poster

Illustrated with "Self-Portrait with Orange Shawl" by Gordon Conway, 1924. \$7.50.

Available through the Octagon, 1799 New York Ave. N.W., Washington, D.C. 20006 (638-3105).

Thornton Exhibition Poster

Poster from 1976 Octagon exhibition featuring Saint-Memin's profile of Dr.

William Thornton owned by the Octagon. *Available through the Octagon, 1799 New York Ave. N.W., Washington, D.C. 20006 (638-3105).*

Wind Energy Poster (4-M233)

Front side illustrates the history of wind-harnessing devices for mechanical and electrical power from pre-Christian times to the present. Back side gives an account of technical design information for modern wind energy conversion systems, and a list of manufacturers, research organizations and literature references. Includes a summary in French and German. Developed by Vonier and Wolff. Four-color, 24x30 inches. \$4.

Available through Publications Fulfillment Office (626-7332).

Practice**The AIA Handbook (1-HBC1)**

Chapter 1 (1973) of the Architect's Handbook of Professional Practice, this document includes general information on the Handbook, including the preface, table of contents, general index and information on chapter. \$.60/\$.90.

Available through Publications Fulfillment Office (626-7332).

Architect's Handbook of Professional Practice (1-M104)

Three-volume set in ring binders includes samples of all A, B, C, D, E and G documents, plus 18 chapters and a glossary of construction industry terms. \$30/\$45. Contents only (no binders), \$20/\$30 (1-M104A). Three binders (no contents), \$10/\$15 (1-M104B). Individual chapters of the Handbook are listed under **AIA Documents**, and described under the subjects they cover.

Available through Publications Fulfillment Office (626-7332).

Architect's Handbook of Professional Practice—Supplement Service (4-Z100)

Subscriptions to the Supplement Service bring the latest editions of the documents contained in the handbook to subscribers. \$16.

Available through Publications Fulfillment Office (626-7332).

Current Techniques in Architectural Practice (2-M701)

Book (1976) edited by Robert Allan Class, AIA, and Robert E. Koehler, Hon. AIA. An overview of architectural practice, with emphasis on management, plus

a comprehensive, annotated bibliography. Published jointly by AIA and Architectural Record Books. 275 pages; \$22/\$27.50.

Available through Publications Fulfillment Office (626-7332).

Project Checklist (1-D200)

30-page publication (1973) provides a complete checklist of tasks necessary to design and administer the construction of a building project. Guide should be used as a project record on every project. \$1.25/\$1.80.

Available through Publications Fulfillment Office (626-7332).

Project Delivery Approaches: An AIA Guide (2-M702)

Primer (1976) edited by David S. Haviland of the AIA project management systems task force and planned as the nucleus and framework for AIA development of a series of studies and guidelines for responsive and creative project delivery approaches. 30 pages; \$3.25/\$4.

Available through Publications Fulfillment Office (626-7332).

Project Procedures (1-HBC11)

Chapter 11 (1969) of the Architect's Handbook of Professional Practice, this document outlines architect and owner responsibilities, organizing the project, instructions for the job captain, scheduling project services, project program, schematic design, design development, construction documents and construction, cost of rendering service and the project record book. \$1.20/\$1.80.

Available through Publications Fulfillment Office (626-7332).

Survey of Southern California Housing

100 color slides with booklet. Illustrates the great variety of housing, including mansions in Beverly Hills, "cliff-hangers" in Hollywood, the ghetto in Watts, beach places in Malibu and apartment buildings and housing throughout the area. Rent \$15 to AIA members only.

Available through Audiovisual Department, Library (626-7495).

For further information about contract forms, liability and the use of the Architect's Handbook of Professional Practice, contact the Documents Office, 626-7440.

For other specific questions relating to architectural practice, contact the Practice Office, 626-7454.

Presentation Techniques

Making Effective Presentations (4-T105)

Eight-step correspondence course dealing with techniques of conducting presentations, client reaction to presentations and post-presentation follow-through. \$85.

Available through Professional Development Office (626-7355).

Professional Development

AIA/Construction Products

Manufacturers Council Programs

Programs dealing with production technology for architectural firms.

Contact Professional Development Office, 626-7355.

AIA Professional Development Catalog (4-N210)

List of all AIA-approved professional development programs dealing with such subjects as personal skills, marketing, practice management, design, production technology, codes and standards, environmental analysis, extended practice and public interest issues. Programs are developed by AIA, educational institutions, other professional organizations and independent firms and individuals. Free to members and components; \$5 to others.

Available from Professional Development Office (626-7355).

Architectural Correspondence Programs

Long-distance courses that enable the architect, or a team of architects, to interact with a group of experts, aided by a specially programmed computer in New York. Printed materials are sent, and the architect then proceeds at his or her own pace, in contact with these specialists and the computer each step of the way.

Achieving Results with Words (T104) \$110

Conducting Successful Energy Audits (T108) \$125

Land Development Game Seminar (T102) \$95.

Making Effective Presentations (T105) \$85

Managing a Professional Practice (T107) \$85

Successful Marketing of Architectural Services (T103) \$85

Successful Selling of Professional Services (T106) \$85

Order by title and number from Professional Development Office (626-7355).

Architectural Training Laboratories

One- or two-day programs focusing on specific topics of interest to architects. Each laboratory is conducted by a nationally recognized authority in the subject area. The programs are designed and pro-

duced by AIA for implementation by state, regional and local components. Developing Profitable Architectural Fees:

The How-To of Cost-Based Compensation

Effective Time Management

Financial Management for Architects

Investment Strategies for Project Success

Profit Decisions For Project Success

Contact Professional Development Office, 626-7355.

Cassette Library

Special subject cassettes are designed to give the architect a balanced survey of the subject as it applies to professional situations. AIA member/nonmember prices are given.

Building Evaluation (3-S212) \$10/\$12.

Designing Your Brochure as an Aid in Marketing Your Services (3-S224) \$10/\$12.

The Management of Time (3-S216) \$10/\$12.

Selling Architectural Services I (3-S207) \$10/\$12.

Selling Architectural Services II (3-S218) \$10/\$12.

Setting Up and Architectural Firm (3-S229) \$10/\$12.

Available through Publications Fulfillment Office (626-7332).

Convention Cassettes—1981

Cassette recordings of the theme programs and seminars of the 1981 AIA Convention. Individual tapes \$5 or any set of six \$28, plus postage and handling (\$1 per tape, \$3 maximum).

Architects on Energy: The Shape of Things to Come, 2 parts

Audit & Retrofit, 2 parts

Computers in Practice, 2 parts

Design & Transformation, Ralph Knowles

Earth-sheltered Design, 2 parts

Emerging Technologies, 2 parts

Energy Conservation Awards Case Study, 2 parts

Energy Economics, 2 parts

Energy in Design: Techniques, 6 parts

Financial Management for Architects, 4 parts

Glass, Windows & Energy, 2 parts

History & Technology: The New American Heritage

Lighting & Daylighting, 2 parts

Management of the Energy-conscious Design Process, 4 parts

Marketing Energy Services, 2 parts

Policy Development & Design, 2 parts

Preservation & Energy, 2 parts

Solar Heating & Cooling, 2 parts

Mail all orders to Dis-Com Inc., Discovery Communications, 3585 Lexington Ave. N., Arden Hills, Minn. 55112.

Intern-Architect Development Program (IDP)

Counseling Materials: The AIA department of education and professional development and the National Council of Architectural Registration Boards, partners in the intern-architect development program, will use the counseling network to provide information packages to local professional advisers who will be in direct contact with intern-architects. Information will focus on broad career options, immediate job opportunities, economic outlook, the future of the profession and AIA programs and activities. Free descriptive circulars are available.

Contact NCARB, 783-6500.

Local Professional Seminars

Programs produced, sponsored and presented by local components of AIA or jointly with another program producer. They are directed to specific local audience needs and draw upon resources of the area.

Architecture and Law
Architectural Office Practice
Building Code Seminar
Practice Management
Specification Seminar
Specification Workshop on the Technical Section

Contact Professional Development Office, 626-7355.

Minnesota Compendium of Professional Development Programs

Collection includes curriculum outlines of 12 recent component continuing education programs: architecture and the law—conflicts and issues, acoustical design, summer design series, marketing design services, an architectural study tour of Toronto, projects cost benefit analysis, energy maxi-audit procedures, graphics, signage, personal financial management and others. \$5.

Available through Minnesota Society AIA, 314 Clifton Ave., Minneapolis, Minn. 55403, (612) 874-8771.

National Professional Seminars

Produced, sponsored and presented by AIA or by an approved national program producer.

AIA Energy
Architect Woodwork Seminar
Barrier-Free Design
Basic Techniques of Systems Drafting #1
Basic Techniques of Systems Drafting #2
Computerized Building Energy Analysis
Condominium Conversion
A Day at Taliesin West: A Forward Look

Design and Analysis/Subterranean
Developing Subsidized Housing
The Development of Real Property
Financial Management of Design and Planning Firms
How to Plan, Site and Merchandise the Smaller House
Land Use Law for Planners/Developers
Landscape Resource Analysis
MASTERSPEC
Passive Studio—Design for Heating, Cooling and Daylighting
PLEC Systems
Problem Solving with CPM
Professional Liability
Realities of Historic Preservation
Roofing Construction Techniques
Solar Energy Building Design
Solar Energy Savings
Terrain Analysis
Urban Design
Value Engineering Training Workshop
Contact Professional Development Office, 626-7355.

Programs Approved By Professional Development Network

Programs planned to give architects and other professionals a basic technical understanding in pertinent areas. Three to four hours each. Continuing Education Units (CEUs) are awarded to participants upon completion.

For information on content, instructors and locations, contact Professional Development Office, 626-7355.

Regional Professional Seminars

Presented by expert in the particular subject or a team. The typical format is a presentation of material followed by group discussion and practical exercises. Developed by AIA or by AIA-approved program producers and presented for statewide or regional audiences.

Commercial Advantages from Historic Preservation

Design with Solar Energy
Computer Applications/Architectural Computer Based Systems
Conscious Energy Use in Buildings
Going Under to Stay on Top: Housing
Promoting Professional Services
Summer Design Series
Uniform Building Code
Contact Professional Development Office, 626-7354.

SupEdGuides (2-N206)

The AIA supplementary education program guides provide new learning opportunities and enlarge upon the normal on-the-job learning experiences. Each guide is \$2.80 to AIA members, \$3.50 for non-members. Complete set (excluding A1) \$72/\$90. SupEdGuide catalog \$5.

(4-N206-0)
Architects' Roles (A1)

Budgeting Project Costs (E4)
Changes in the Work (F7)
Claims and Disputes During Construction (F9)
Client Relations During Design (E2)
Construction Contract Documents (F2)
Construction Progress Payments (F8)
Controlling Project Time (E5)
Delivery Approach (D5)
Design Documentation (E7)
Energy Analysis for Building Design (G1)
Energy Audits (G2)
External Arrangements (B6)
Financial Aspects of Practice (B3)
Financing (D4)
Information Requirements in Design (E6)
Insurance Aspects of Practice (B5)
Internal Office Arrangements (B2)
Legal and Ethical Considerations (B4)
Marketing Methods (C2)
Negotiating the Owner-Architect Agreement (E1)
Organizing for Getting Business (C1)
Program (D2)
Progress of the Work (F4)
Project Initiation (D1)
Proposal and Award (F1)
Selecting the Team Members (E3)
Site (D3)
Site Visits (F5)
Submittals and Approvals (F6)
Types of Practice (B1)
Available through Publications Fulfillment Office (626-7332).

Professional Interest Programs

Corresponding Committee Membership

Available to all AIA members. For a per committee/per year registration fee, corresponding committee members receive all notices, meeting minutes and reports of the committee; participate in committee meetings and activities to the degree desired, and contribute to committee tasks and deliberations as they wish. The committees with corresponding membership are:

Architects in Education
Architects in Government
Architects in Industry
Architecture for the Arts and Recreation
Architecture for Commerce and Industry
Architecture for Education
Architecture for Health
Architecture for Justice
Codes and Standards
Design
Energy

Pr

Historic Resources
Housing
Interiors
Practice Management
Professional Development
Public Education
Regional Development and Natural Resources
Urban Planning and Design
Contact Program and Services Management Group Office, 626-7317.

Professional Interest Programs/Seminars
Annual seminars bring together architects with similar professional interests. Interchange provides architects with resources to improve the quality of design and professional services for the client. Seminars planned for fall 1981 are:
Commerce and Industry, Oct. 4-6, Detroit;
Justice, Oct. 1-3, Toronto.
Contact Professional Interest Programs Office, 626-7365.

Programming

The Architect's Guide to Facility Programming (2-M726)

A thorough examination (1981) of contemporary programming in architecture, including role, process, techniques, tools, applications (via case studies) and opportunities. \$28/\$34.95.
Available through Publications Fulfillment Office (626-7332).

Emerging Techniques 2—Architectural Programming (4-M201)

Book (1968) by Benjamin H. Evans, AIA, and C. Herbert Wheeler Jr., FAIA, describing the means through which data about the needs of the ultimate building user are determined and expressed from the instruction of the architect to the design solution. 68 pages; \$3.
Available through Publications Fulfillment Office (626-7332).

For further information about programming in general, contact the Practice Office, 626-7454.

Project Delivery

The Architect's Guide to Facility Programming (2-M726)

A thorough examination (1981) of contemporary programming in architecture, including role, process, techniques, tools, applications (via case studies) and opportunities. \$28/\$34.95.
Available through Publications Fulfillment Office (626-7332).

Design/Build/Bid: An Owner's Guide (6-N903)

Booklet (1975) to assist a potential public sector client in evaluation of the design-build-bid process. Free.
Available through Publications Fulfillment Office (626-7332).

Emerging Techniques 2—Architectural Programming (2-M201)

Book (1968) by Benjamin H. Evans, AIA, and C. Herbert Wheeler, Jr., FAIA, that describes the means through which data about the needs of the ultimate building user are determined and expressed from the instruction of the architect to the design solution. 68 pages; \$3.
Available through Publications Fulfillment Office (626-7332).

Professional Construction Management and Project Administration (3-M121)

Book (second edition, 1976) by William B. Foxhall looks at new professional services and who provides them. Published jointly by AIA and *Architectural Record*. 125 pages; \$22.50/\$25.
Available through Publications Fulfillment Office (626-7332).

Project Delivery Approaches: An AIA Guide (2-M702)

Publication (1976) edited by David S. Haviland of the AIA project management systems task force, guide is essentially a primer planned as the nucleus and framework for AIA series of studies and guidelines for responsive and creative project delivery approaches. 30 pages; \$3.25/\$4.
Available through Publications Fulfillment Office (626-7332).

Public Buildings

Forum on Public Architecture: A Conference for Government Administrators—A Resource Book

Collection of articles (1976) on public architecture, presenting significant state and local activity in such areas as energy conservation, land use and adaptive use. 142 pages; free.
Available through Government Affairs Office (626-7375).

Special Obligations: Issues in the Administration of Public Architecture

Program highlights of conference presentations and discussion between state and local government administrators concerning constraints and opportunities in public architecture (1977).
Available through Government Affairs Office (626-7375).

For further information about public buildings in general, contact Government Affairs Office, 626-7375.

Public Relations

Adaptive Re-Use: Extending the Life of Old Buildings (6-N827)

Using recent AIA honor award winning buildings as examples, this pamphlet describes the growing trend in architecture that advocates the adaptive use of older structures to give them new life in the modern world. Examples include Boston's Faneuil Hall, San Francisco's Cannery and Ghirardelli Square and Chicago's Navy Pier. Free.

Available through Publications Fulfillment Office (626-7332) or Public Relations Department (626-7460).

The AIA Asks: Why? Why Not?: Program Package 1 (6-N807)

Explains how to place a series of pictures and captions about good and bad environmental features in local newspapers. Describes the program, gives ideas for pictures and captions, provides "how-to" information about approaching the newspaper, etc. 25 pages (1974); free.
Available through Publications Fulfillment Office (626-7332) or Public Relations Department (626-7460).

AIA Emblem for Printing

Instruction sheet regarding rules for use of AIA emblem. Two sheets of reproducible emblems in various sizes for use on letterheads, etc. Free. Limited quantities.
Available through Public Relations Department (626-7460).

AIA Memo

Newsletter, published twice a month, sent to the entire membership. Aims to keep members abreast of Institute programs, achievements, services, etc. Free.
Available through Public Relations Department (626-7460).

Architects Bite! Right? (6-N830)

Flyer (1980) written for general audience and designed for distribution by components at home shows, etc., to promote client awareness. Consists of a series of common myths about architects that are disproved through case studies illustrating successful architect/client relationships. Free.

Available through Public Relations Department (626-7460) or Publications Fulfillment Office (626-7332).

Built Environment Education: Program Package 10 (6-N824)

Folder highlighting a built environment education program for elementary school students developed and implemented by an architect. Includes a step-by-step sample program outline, plus a guide to re-

sources and information on built environment education. Free.

Available through Publications Fulfillment Office (626-7332) or Public Relations Department (626-7460).

Celebrating American Architecture (4-N825)

Set of 80 slides depicting 1979 national honor award and 25-year award winning buildings. Script is included to provide brief descriptions of the structures. \$18 prepaid.

Available through Publications Fulfillment Office (626-7332).

Celebrating Excellence: Program Package 11 (6-N829)

A "how-to" guide that addresses AIA components interested in setting up successful awards programs. With documented examples from Florida Association/AIA, Houston Chapter/AIA and other components' efforts, this package provides useful, basic information and guidelines for each step of the program. An insert of the AIA Board Guidelines for Component Awards Programs is included. Free to component executives and public relations committee chairmen.

Available through Publications Fulfillment Office (626-7332) or Public Relations Department (626-7460).

A Celebration of Architecture: 25 Ideas for Components

Slide show and script briefly describe 25 ways for AIA components to focus the public's attention on the built environment. The show outlines projects used to implement AIA's 1979 Celebration of Architecture program—tours, exhibits, guidebooks, etc. An "idea-kit" for components looking for PR projects to undertake. Free loan to components.

Available through Publications Fulfillment Office (626-7332).

Component Editors Critique Service

A program to help improve the skills of editors of component newsletters and magazines. Written critiques by graphic and editorial consultants are available on request.

Contact Public Relations Department, 626-7460.

Component PR Assistance/Counseling

A program that offers different kinds of PR information, program packages, counseling and other aids to help components solve individual PR problems.

Contact Public Relations Department, 626-7460.

Conversation with an Architect

Two-page flyer describing theme and subject matter of 1975 film by same title. Free.

Available through Public Relations Department (626-7460).

Designing Your Brochure as an Aid in Marketing Your Services (3-S224)

One-hour cassette (1976) tells how to gear your brochure to your desired market by making it convey your firm's personality, your ability to take care of the client, your problem-solving ability, the range of your services, etc. The contents of an "ideal" brochure are outlined. \$10/\$12.

Available through Publications Fulfillment Office (626-7332).

Dun's Review Reprint (4-N8360Q)

"Constructing the Cost-Effective Facility: Corporate Options in the '80s" from January 1981 issue. This article focusing on energy conscious design can be used as a handout for corporate groups or clients. Single copy free. \$6 per 10 copies.

Available through Public Relations Department (626-7460) or the Publications Fulfillment Office (626-7332).

Effective Public Relations

This manual is geared specifically to the needs of the component PR chairmen. It spells out the basic principles of PR planning and offers suggestions for effective use of the media and increasing a component's visibility. Free to component executives and PR chairmen.

Available through the Public Relations Department (626-7460).

Energy Efficiency Needn't Cloud Your Life (4-N834)

Brochure of value to homeowners. Single copy free.

Available through Public Relations Department (626-7460) or Publications Fulfillment Office (626-7332).

Environments for People: Program Package 5 (4-N812)

80 slides, introduction, script and suggestions for use (1976). Explains how architects provide for basic human needs (shelter, privacy, personalization, socializing, mobility, communication) in their design of the human environment. \$20 prepaid.

Available through Publications Fulfillment Office (626-7332) or Public Relations Department (626-7460).

Hold on to Your Heat (and Keep Your Cool) (6-N906)

Pamphlet (1976) intended as a homeowner's guide to energy conservation. Describes how to take advantage of site, envelope, floor plan, windows, insulation, etc., to conserve energy. Includes bibliography. Free.

Available through Publications Fulfillment Office (626-7332).

Houston Architecture April Festival: Program Package 7 (6-N831)

A folder (1976) explaining how the

Houston Chapter/AIA held a month-long festival to increase public awareness and appreciation of architecture and architects. Includes descriptions of individual events, their planning, cost and publicity. Illustrated with news clips about the festival and samples of poster, tickets and map graphics used by the chapter. Free to component executives and PR chairmen.

Available through Publications Fulfillment Office (626-7332) or Public Relations Department (626-7460).

How Architecture Speaks: Program Package 2 (4-N808)

43 slides, guidelines, script and quiz sheets (1974) that show people how architecture "speaks" through form, color, scale, texture, materials. Quiz tests people's reactions to structures. \$18 prepaid.

Available through Publications Fulfillment Office (626-7332) or Public Relations Department (626-7460).

Indianapolis Architecture Guidebook: Program Package 8 (6-N832)

Folder (1977) describing the process by which Indianapolis Chapter/AIA published an extensive guidebook of that city. Includes sections on why to write a guidebook, forming a committee, fund-raising, budgeting, selecting printer and designer and publicizing the project and the product. Free to component executives and PR committee chairmen.

Available through Publications Fulfillment Office (626-7332) or Public Relations Department (626-7460).

A Line on Design and Energy: Ways to Make it Happen

80 slides and script for use by components for developing visibility programs within their communities to promote the "Line on Design and Energy" theme. Free loan to components.

Available through the Public Relations Department (626-7460).

News Clipping Clearinghouse 1977

Two collections of news clippings to aid the component in dealing with local newspapers. The first collection explains "How You Can Get Publicity Through AIA Participation in Public Affairs." News clips illustrate successful public affairs projects undertaken by components. These clips show what makes news; gives ideas for programs to generate publicity. The second collection gives "Suggestions on Placing Articles in Your Local Paper," through samples of published articles written by AIA members. These clips may be used as guides for submitting articles to local papers. Free to component executives and PR committee chairmen.

Available through Public Relations Office (626-7460).

No Little Plans

16mm film, 18 minutes. The history of the AIA and its services today, featuring Elmer Botsai, FAIA; Wolf Von Eckardt, Hon. AIA, and Winfield Rankin, Hon. AIA; includes material drawn from the AIA archives and library. Free loan to AIA components and chapters. Available through *Audiovisual Department, Library* (626-7495).

Nobody Wants to Listen to Your Problems—Right? Wrong

(6-N814) Companion pamphlet to 1974 ad series encouraging clients to “plan now.” (“One of these days you’re going to build . . .” “When you think it’s too soon to call an architect . . .” and “There’s a way to save on your next building.”) Consists of case studies demonstrating advantages of hiring an architect for planning although construction time is indefinite. Free. Available through *Public Relations Department* (626-7460).

Orchids and Onions: Program Package 4

(6-N811) Folder (1975) explaining how components can carry on a program that asks the public to nominate organizations and individuals who make good or bad contributions to the man-made environment; a jury selects the winners. Based on a project of the Western Communities Architects’ Association, a section of the Chicago Chapter/AIA. Free to component executives and PR committee chairmen.

Available through *Publications Fulfillment Office* (626-7332) or *Public Relations Department* (626-7460).

The Octagon

Brochure containing a brief history of the Octagon, its hours of opening, etc. Free. Available through *the Octagon, 1799 New York Ave. N.W., Washington, D.C. 20006* (638-3105).

Prescriptive Standards: No Rx for Energy Conservation in Buildings

(6-N816) Folder (1976) promoting performance-oriented standards for energy conservation, rather than prescriptive standards. Free.

Available through *Publications Fulfillment Office* (626-7332) or *Public Relations Department* (626-7460).

A Public Relations Idea Kit: “A Line on Design and Energy”

Kit explores ways for components to make the most of the design and energy theme at the local level. Contains ideas for component programs and activities—energy fairs, tours, articles, displays, TV and radio spots and much more. Free to

component executives or PR chairmen. Available through *the Public Relations Department* (626-7460).

Report of the Board

Annual Report of AIA. Free. Available through *the Public Relations Department* (626-7460).

Sample Articles for Components

A collection of sample articles to help AIA components encourage newspaper editors to run regular columns on architecture in local papers. Each article discusses a different aspect of architecture of interest to the public. Free to components. Available through *the Public Relations Department* (626-7460).

Sample TV and Radio Public Service Announcements

A “how to” packet on PR planning and effective use of public service announcements. Contains five sample PSAs. Free to component executives and PR chairmen.

Available through *the Public Relations Department* (626-7460).

Saving Energy in the Built Environment: The AIA Policy

(6-N904) Brochure (1975) summarizing two previous publications: “Energy and the Built Environment: A Gap in Current Strategies”; “A Nation of Energy Efficient Buildings by 1990.” Free. Available through *Publications Fulfillment Office* (626-7332).

The Solar Advantage

(4-N820) Pamphlet (1978) briefly describing current studies and legislation concerning solar energy. Results of recent research are applied to the energy efficiency of residences. Free.

Available through *Director, Energy Programs* (626-7448).

10 Buildings That Save Energy—By Design

(6-N835Q) A new brochure for nonresidential clients. Single copy free. \$5 per 100.

Available through *the Public Relations Department* (626-7460) or *Publications Fulfillment Office* (626-7332).

Three Articles on Energy

Suitable for placing with your local media. Free to component executives and PR committee chairmen.

Available through *the Public Relations Department* (626-7460).

What Architects Do

Public relations brochure covering topics such as selecting an architect, costs, functions and savings, making the most of the natural environment, how an architect can save you money, what construction involves and how to pay the architect. \$1. Available through *the Minnesota Society AIA, 314 Clifton Ave., Minneapolis, Minn. 55403, (612) 874-8771.*

What Do They Have in Common?

Program Package 9

(4-N604) 80 slides of American architecture designed by women. Slides run gamut from solar homes to urban hospitals, from Manhattan to California. Package includes viewer handouts, guidelines for suggested use. Appropriate for career guidance, public awareness presentations, slides can be shown without narration. \$20.

Available through *Publications Fulfillment Office* (626-7332) or *Public Relations Department* (626-7460).

You and Your Architect

(4-N802) A booklet answering client questions about the selection and compensation of an architect. Outlines the responsibilities of an architect, client and other members of the building team during design and construction. Revised in 1980. Free. Available through *Publications Fulfillment Office* (626-7332).

For further information about public relations in general, contact *Public Relations Department, 626-7460.*

Publications Sales

Publications Price List and Order Form

(6-N702) List of AIA books and manuals available for sale through AIA. Free. Available through *Publications Fulfillment Office* (626-7332).

Publications Sales

AIA sells documents, books, audiovisual materials, etc., to architects, components and the public. Members and components are entitled to varying discounts depending on nature of the publications. Contact *Publications Marketing/Sales Office* (626-7474).

For further information about publications that are sold and to place orders, contact *the Publications Fulfillment Office, 626-7332.*

Railroad Stations

Stations

Color film, 16mm, 28 minutes (1974). Shows many of the interesting and innovative uses being made of old railroad stations, in order to preserve these landmarks. Rent \$15 to AIA members only. Available through *Audiovisual Department, Library* (626-7495).

Real Estate

Land Development For Architects (4-T102)

Six-step correspondence course to teach how to do land development through actual experience. \$95.
Available through Professional Development Office (626-7355).

Registration

AIA Index to Registration Law Resources

Listing of registration law studies, surveys, bibliographies and reports that are available upon request to AIA components (1981). Free.

Available through Government Affairs Office (626-7375).

Architect/Engineer Licensing: Enforcement Case Law

AIA report on case law associated with suspension and revocation of architect and engineer licenses by state registration boards (1981). Free.

Available through Government Affairs Office (626-7375).

Architect/Engineer Licensing: Legal Distinctions

AIA report discussing case law concerning overlap of architectural and engineering services (1981). Free.

Available through Government Affairs Office (626-7375).

Architectural Licensing: Legislative Options

A component guide containing discussion of public regulation, types of licensing laws and key provisions contained in most licensing laws (1981). Free.

Available through Government Affairs Office (626-7375).

Architectural Registration: The Examination Issue

An AIA report discussing NCARB registration examinations, the NCARB practice analysis and test validation project and status of examination revision projects in several states (1980). Free.

Available through Government Affairs Office (626-7375).

Designer Registration Overview

AIA report containing description of registration efforts of various designer groups, including interior designers, residential designers and others (1980). Free.

Available through Government Affairs Office (626-7375).

Professional Development Requirements for License Maintenance: A Strategy Guide for AIA Components

An AIA component guide dealing with legislation and regulations, policy and strategies related to architect license renewal requirements, including mandatory continuing education (revised 1981). Free.

Available through Government Affairs Office (626-7375).

Registration Law Policy Statements

AIA board-approved policy statements developed by the AIA registration law advisory task force covering a wide range of registration related policies (1980). Free.

Available through Government Affairs Office (626-7375).

Revising Architectural Registration Laws: Strategy Consideration

Contains a 1975 survey report on the issues and political processes concerning architectural registration laws, including strategies for legislative action (1976). Free.

Available through Government Affairs Office (626-7375).

Sunset Laws: A Strategy Guide for AIA Components

Contains discussion of the pros and cons of sunset legislation, recommended elements of an effective sunset law and possible component activities during sunset reviews of architectural registration boards and other agencies (1978). Free.

Available through Government Affairs Office (626-7375).

Sunset Overview: Architectural Registration Boards

Contains description of sunset review experiences of 19 architectural registration boards and procedures to be followed in other states with sunset laws in effect (1980). Free.

Available through Government Affairs Office (626-7375).

For further information about registration of architects in general, contact the National Council of Architectural Registration Boards, at AIA Headquarters, 783-6500. For further information about registration laws, contact Government Affairs Office, 626-7375.

Research

Library Research Services

The library staff will respond to questions, either in person, by telephone or by letter, on aspects of architecture and construction, architectural history, building types, etc., using the library's cataloged

volumes, reference books, indexes and more than 400 current periodicals. Free. Contact the Library, 626-7493.

Research and Design

Previously published four times a year by the AIA Research Corporation, the publication has been suspended indefinitely. Single copies of past issues are available for \$4. Payments must be received in advance.

Available through AIA Research Corporation (626-7500).

Signs

Model Sign Control Ordinance

15-page guide (1965) prepared by the AIA commission on environment and design to help communities write sign control regulations. Free.

Available through Design Office (626-7359).

Specifications

Construction Documents—Specifications (1-HBC14)

Chapter 14 (1972) of the Architect's Handbook of Professional Practice, this document includes information on writing specifications, procedure, form, policy, method versus result, production and specification references. \$1.80/\$1.20.

Available through Publications Fulfillment Office (626-7332).

An Introduction to Masterspec 2

Slide show explaining the master specification system designed to help the architect remain competent and competitive. Consists of a carousel tray of 85 slides and a 20-minute cassette tape. Free loan; available only for organized meetings and seminars.

Contact PSAE, a wholly owned corporation of AIA, at AIA headquarters, 626-7550.

Masterspec 2—The Comprehensive Specification System

12-page brochure, describing the Masterspec 2 system including details about the new stand-alone basic version, which is particularly relevant to small general practice firms. Further information and samples available. Free.

Contact PSAE, a wholly owned corporation of AIA, at AIA headquarters, 626-7550.

Masterspec 2 Workshops

One-day continuing education course on Masterspec 2 consisting of lectures, hands-on exercises and a slide show of specification systemization theory and practice. Workshops are designed to enable design professionals to understand, evaluate and utilize master specification technology and the adaptable Masterspec 2 system and its primary stand-alone basic version. Masterspec 2 workshops are available to recognized organizations at PSAE's discretion, anywhere in the continental U.S. for a minimum of 25 preregistered attendees, on a first-come-first-served basis. Scheduling of a workshop requires a local sponsor to provide local promotion, space, lunch and coffee. Eight contact hours, 0.8 AIA CEU's.

Contact PSAE, a wholly owned corporation of AIA, at AIA headquarters, 626-7550.

For further information about specifications in general, contact Production Systems for Architects and Engineers, Inc. (PSAE), at AIA Headquarters, 626-7550.

Transportation

For information about transportation planning in general, contact the Design Office, 626-7359.

Underground

Building Underground for People: Eleven Selected Projects in the United States (3-M711)

Report (1978) by Michael Barker documenting a sampling of underground projects that involve human habitation in the U.S. Information includes description of each project, owner, design team, contractor, size, cost, date of completion and decision to build subsurface. 30 pages; \$6/\$7.

Available through Publications Fulfillment Office (626-7332).

Urban Planning

Blueprints for the Future

16mm color/sound film, 30 minutes (1965) that presents several master plans for Houston. A study of the architectural needs of the total city. Free loan.

Available through Houston Chapter/AIA, 3121 Buffalo Speedway, Suite 404, Houston, Tex. 77098, (713) 629-0191.

Downtowns for People

Color 16mm film, 26 minutes (1972) showing examples of European and American downtown areas from the pedestrian's viewpoint. Free loan to AIA members only, no sale.

Available through Audiovisual Department, Library (626-7495).

Innovations in State Legislation: Land Use Management; Environment and Land-Use: Two California Experiments

Two publications (1973 and 1975) by Richard N. Tager, offered as one unit. The first is an overview of the role states can play in implementing the fundamental recommendations of the AIA national policy task force. The second report discusses the background and provisions of CEQA and the Coastal Zone Act.

Available through Design and Environment Programs Office (626-7363).

Lafayette R/UDAT

Color film, 16mm, 25 minutes (1978), documents the AIA R/UDAT visit to Lafayette, La. Free loan to AIA members. Available through Audiovisual Department, Library (626-7495).

Los Angeles: 20th Century American City

Color slides with booklet. Explores important aspects of new trends and problems in contemporary urban development: urban sprawl, low-density ghetto, freeway systems, leisure facilities, land use patterns. Rent \$15 to AIA members only. Available through Audiovisual Department, Library (626-7495).

R/UDAT Program

Through the Regional/Urban Design Assistance Team Program, chapters can arrange for a team of AIA members and other specialists to visit their communities and advise them on specific community planning and urban design problems or on long-range goals in regional planning.

Contact Design and Environment Programs Office, 626-7363.

R/UDAT: Regional/Urban Design Assistance Teams: A Program of the American Institute of Architects (6-N405)

Pamphlet (1976), addressed to community leaders, describing the R/UDAT program. Prepared by the AIA urban planning and design committee. Free. Available through Publications Fulfillment Office (626-7332).

R/UDAT Report on Forest Park, St. Louis

Facts and proposals (1976) for this green area established following the 1904 St. Louis World's Fair. Free.

Available through St. Louis Chapter/AIA, 919 Olive St., St. Louis, Mo. 63101, (314) 621-3484.

R/UDAT Reports

Reports of recent R/UDAT visits available upon request. \$3-\$5.

Available through Design and Environment Programs Office (626-7363).

What is Regionalism?

AIA JOURNAL reprint on regional planning and development. Free.

Available through Design and Environment Programs Office (626-7363).

For further information about urban planning in general, contact the Design and Environment Programs Office, 626-7363.

Women in Architecture

Directory of Minority and Women Owned Architectural and Engineering Firms (4-M709)

Information (1981) about women and minority owned firms. \$10/\$12.

Available through Publications Fulfillment Office (626-7332).

The Status of Women in Architecture

Report (1975) of the AIA task force on women in architecture, which identifies several major areas where women have been either discriminated against or under-represented in the architectural profession and AIA. 38 pages; free.

Available through Component Services Office (626-7376).

What Do They Have in Common?**Program Package 9** (4-N604)

Slide show of contemporary American architecture designed by women. Included are informational handouts and guidelines for suggested use. The 80 slides run the gamut from solar homes to urban hospitals, from Manhattan to California. Can be shown without narration. \$20.

Available through Public Relations Department (626-7460) or Publications Fulfillment Office (626-7332).

For further information about women in architecture, contact the Coordinator, Women in Architecture, 626-7376.

Working Drawings

Construction Documents—Drawings (1-HBC12)

Chapter 12 (1970) of the Architect's Handbook of Professional Practice, this document includes general comments on drawings, instructions on laying out the work, production and ownership.

\$.60/.90

Available through Publications Fulfillment Office (626-7332).

Powerful Paging!

No other intercom commands attention like the Dukane High Power Intercom. All messages are clearly understood throughout

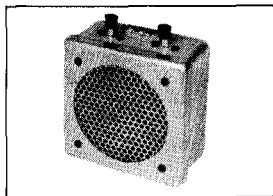

Rugged remote speaker station for industrial application where utility is of prime importance.

factories, shopping centers and airport terminals.

It is also a system

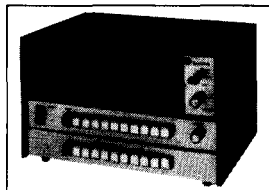

Additional switch banks expand the system.

to build on. Start with 10 stations... expand to 100 as your needs grow.

You'll find the High Power Intercom has a full range of features to make communication simple and

effective. You can switch from paging to background music or all-station communications for general announcements.

No other intercom system packs so much power and performance in a compact, attractive package. And it's made by Dukane, the innovators in sound with years of experience in producing

communications systems for hospitals, schools, businesses and industries.

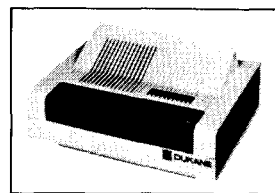

Desk/Wall remote speaker station for intercommunication with master station.

Let us give you the full story on how we can meet your needs. Attach your business card to this ad and send for free information.

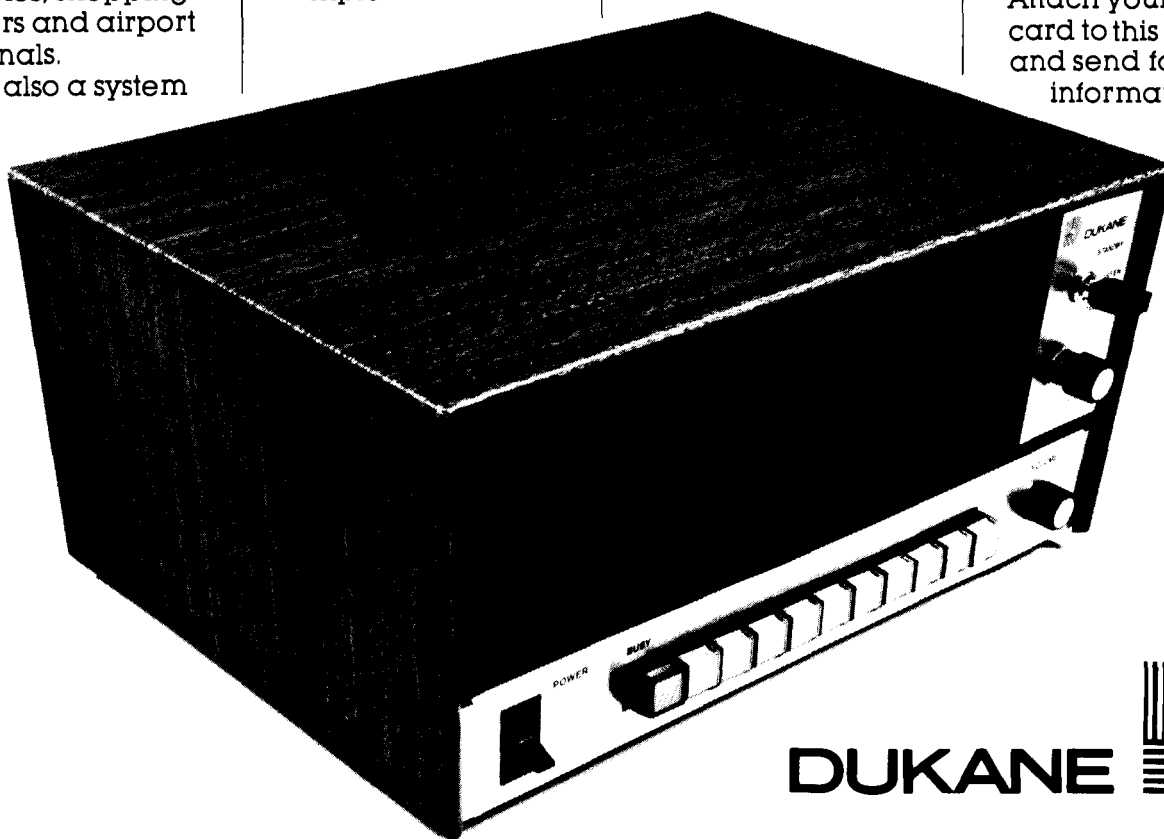

DUKANE 

DUKANE CORPORATION/COMMUNICATIONS SYSTEMS DIVISION/ST. CHARLES, ILLINOIS 60174 312/584-2300

Circle 35 on information card

Rapidograph® Renderings

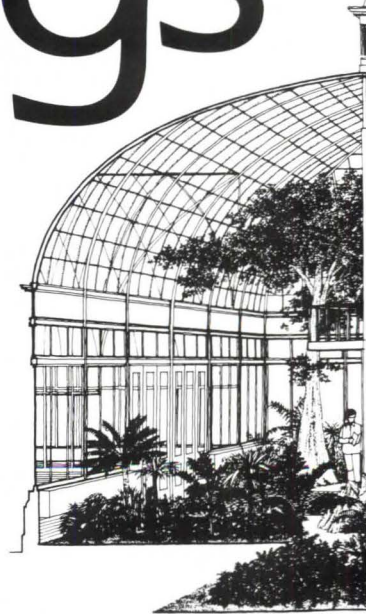
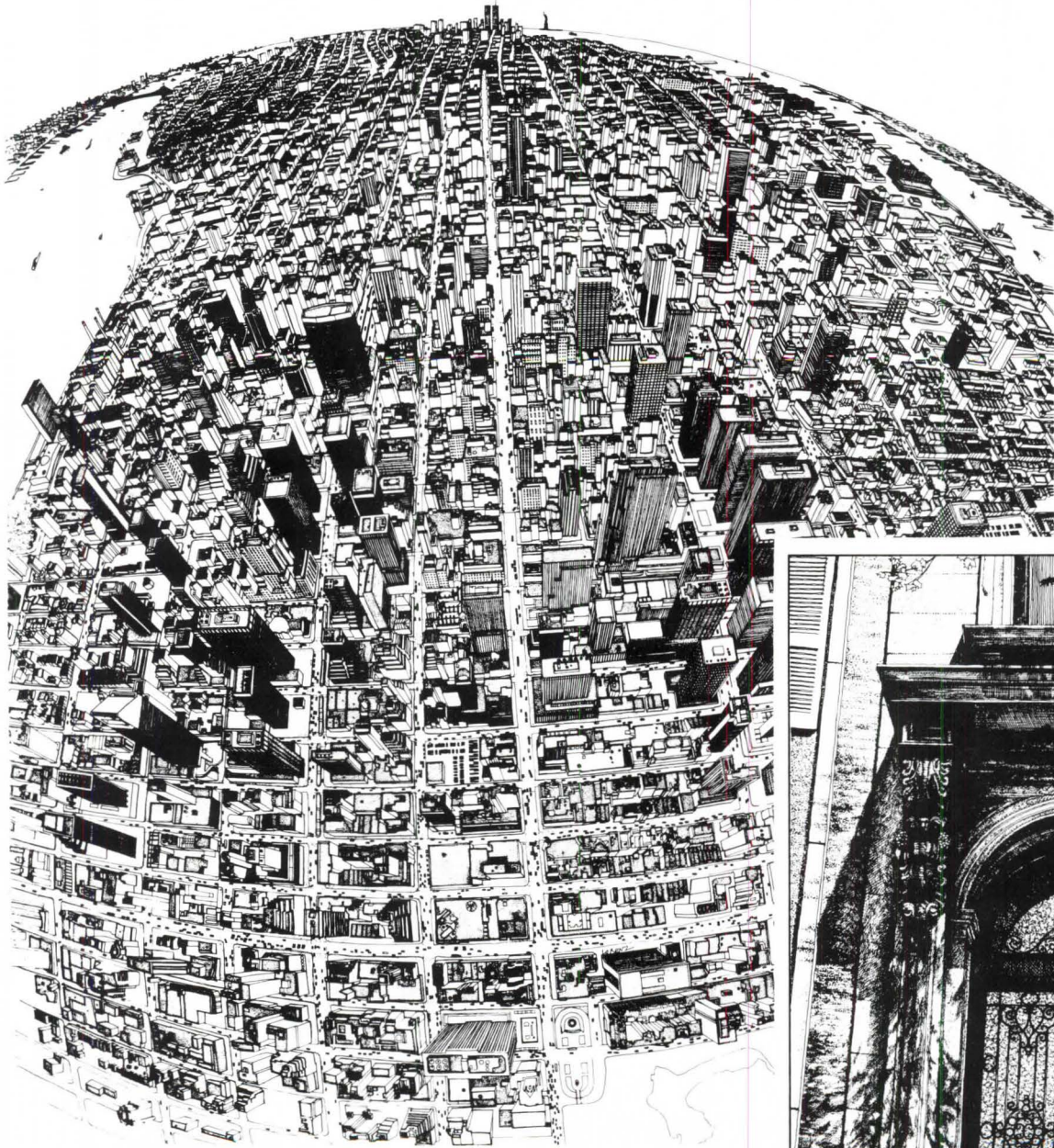

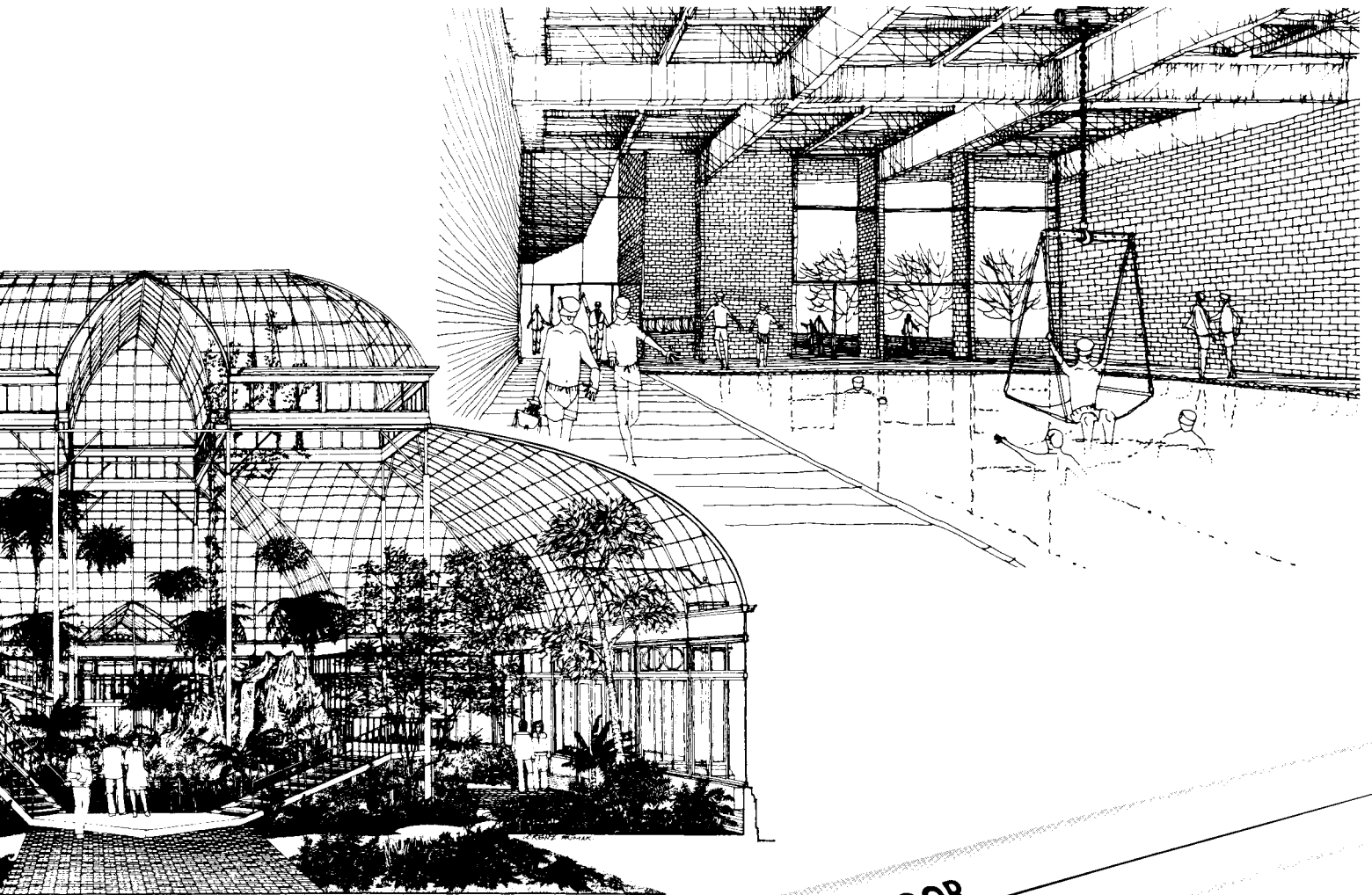

...the versatility of Albert Lorenz

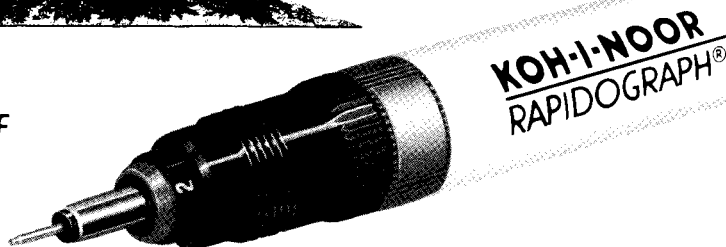

With a Koh-I-Noor Rapidograph Technical Pen and a lot of imagination and skill, artist Lorenz turns architects' proposals into clean, crisp, client-pleasing visuals. His Rapidograph® renderings range from traditional perspectives to fish-eye lens panorama, with loose sketches and tight elevations in between. To assist in this prodigious and versatile output, Al Lorenz relies on Rapidograph® dependability. It is this dependability that makes the Rapidograph the most widely used technical pen in the United States and Canada.

Rapidograph was the first technical pen. It was born in industry in the early 1950's to provide the precision drafting required by engineering design and aerospace industries. It established new and very stringent standards in all disciplines when it was experienced that the Rapidograph made possible high precision engineering drafting with the additional benefits of economy and time savings.

The Koh-I-Noor Rapidograph Pen glides over drawing surfaces with the ease of a pencil because its tubular nib will not snag. In fact, it doesn't require the hand pressure used with pencil; its own weight

on the drawing surface provides a consistent ink laydown. The drafter or artist has only to guide it with an easy, non-fatiguing hold.

A patented DRY DOUBLE-SEAL™ provides an airtight bond between the pen cap and pen body, keeping ink throughout the balanced ink-flow system clog-free, ready for instant startup after days, weeks or even months of storage. The refillable ink cartridge is another appreciated feature, permitting longer, uninterrupted drawing sessions.

Your office or studio might now be using Rapidograph® precision for clean, crisp floor plans and elevations; so let exciting Rapidograph renderings help further your proposals' chances of approval.

Rapidograph is a registered tradename of Koh-I-Noor Rapidograph, Inc. A technical pen is Rapidograph® only if it says Koh-I-Noor Rapidograph® on the barrel.

Consult our Customer Service Department if you would like to know more about technical pens, drawing materials and techniques. Or if you want information about choosing the right inks for your projects,

Koh-I-Noor offers the largest single-source selection of waterproof black india drawing inks, as well as opaque and transparent colored inks: Toll free 800-631-7646; from New Jersey 201-479-4124. In Canada: Toll Free 800-268-4961; or collect 416-671-0696.

KOH-I-NOOR RAPIDOGRAPH®

Please send me complimentary Koh-I-Noor Catalog A, describing Koh-I-Noor Rapidograph Technical Pens, Point Sizes, Koh-I-Noor and Pelikan inks and other materials.

I would like the names of Koh-I-Noor dealers in my area.

NAME _____
(please print or type)

COMPANY _____

ADDRESS _____

CITY _____ STATE _____ ZIP _____

Koh-I-Noor Rapidograph, Inc.
100 North St., Bloomsbury, NJ 08804
In Canada: 1815 Meyerside Dr.,
Mississauga, Ont. L5T 1B4

AIA-8-81

The publications and audiovisual materials listed below are available from various professional organizations, government offices and special interest groups whose work is related to architecture. The list is not meant to be inclusive. Non-member prices are listed.

Acoustical Society of America

Acoustical Designing in Architecture

Book offering a comprehensive, non-mathematical treatment of architectural acoustics. It provides general principles and procedures on which acoustical designing is based and specific applications. By Vern O. Knudsen and Cyril M. Harris. \$15.

Catalog of Acoustical Standards

The society develops standards on physical acoustics, mechanical shock and vibration and bioacoustics for the American National Standards Institute. These are published after approval by ANSI. Free.

The Journal of the Acoustical Society of America

Monthly publication, offered to nonmembers on a subscription basis, covers research and engineering activities in acoustics.

Contact: *Acoustical Society of America*, 335 E. 45 St., New York, N.Y. 10017.

Advisory Council On Historic Preservation

Assessing the Energy Conservation Benefits of Historic Preservation: Methods and Examples

Major study describing a method for determining the total energy cost of any existing buildings. Included are energy embodied in materials and construction, energy needed for operation of the building and energy that would be expended during demolition if the existing structure were replaced by an equivalent new one. \$2.75. Also available is a summary of the study "Preservation and Energy Conservation" (\$2.75) and a 12-minute slide/sound program (\$90/\$15 on loan).

The Contribution of Historic Preservation to Urban Revitalization

Quantifies the social and economic benefits of historic preservation in Old Town, Alexandria, Va.; The Strand, Galveston, Tex.; Pioneer Square, Seattle, and Savannah, Ga. \$4.75. Also available is a summary brochure of the study (\$3) and a 12-minute slide/sound program (\$90/\$15 on loan).

International Centre for the Study of the Preservation and Restoration of Cultural Property

Brochure describing the professional training courses offered by the International Centre, Rome, Italy. Free.

Remember the Neighborhoods: Conserving Neighborhoods through Historic Preservation Techniques

Defines and discusses a series of preservation tools that are proving effective in meeting neighborhood conservation needs.

Report to the President and Congress

Three separate publications present the state of American preservation in 1978, '79 and '80. Each is \$2.50.

Contact: *Advisory Council on Historic Preservation*, 1522 K St. N.W., Washington, D.C. 20005.

American Association Of Engineering Societies

Publications

More than 25 publications examine surveys of industry and universities, the demand for engineers and salaries of engineers, among others. Also available is *Who's Who in Engineering* (\$75) and the *Directory of Engineering Societies* (\$23).

Contact: *American Association of Engineering Societies*, 345 E. 47th St., New York, N.Y. 10017.

American Consulting Engineers Council

ACEC International Engineering Directory

Biennial publication containing two-page profiles of each of the 67 ACEC member firms doing business overseas. \$10.

ACEC Membership Directory

Lists consulting engineering firms alphabetically by state with firm services, principals and addresses. \$25.

The Brochure on Brochures

50 illustrations show design professionals how to prepare an effective firm brochure. \$8.

Buying a Small Computer

Includes information on making the decision to buy a computer, evaluating small computer systems, selection, purchase, installation and proper usage. Cost estimates are included for various levels of computer systems, programs and maintenance agreements. \$10.

Commentary on Agreements for Engineering Services and Contract Documents

Summarizes and analyzes 23 standard

forms used by engineers for project design and other engineering services. \$10.

Directory of Minority and Women-owned Architectural and Engineering Firms—1981

Alphabetical listing by state of over 600 firms, with ownership, staff size and service specialties. \$15.

Energy Tax Credits for Home and Business

Describes the types of home and commercial energy conservation measures that are eligible for tax credits, and contains examples of applicable tax computations. \$4.

A Guide to the Procurement of Architectural and Engineering Services

Fundamental guide for clients responsible for engaging architect/engineer services. \$5.

Individual Retirement Plans

Reflects changes made under the Revenue Act of 1978 and analyzes the tax-sheltered retirement plans individuals may establish, and discusses individual retirement plans, accounts, annuities, government retirement bonds and simplified pension plans. \$4.

Tax Choices in Organizing a Business

Details the importance of tax considerations in determining what type of business organization to establish. Helps to clarify federal tax law with regard to corporations, partnerships, sole proprietorships and professional corporations. \$8.

Tax Saving Plans for Self-Employed

An explanation of self-employed individual retirement plan laws. \$4.

Title 41 Public Contracts and Property Management—Federal Procurement Regulations

Reprint of the regulations that set forth procedures by which the federal government publicly announces, evaluates, selects and negotiates A/E contracts. \$7.

Understanding Professional Liability Insurance

Guide for understanding and choosing a professional liability policy geared to the needs of the individual firm. \$8.

Contact: *American Consulting Engineers Council*, 1015 15th St. N.W., Washington, D.C. 20005.

American Land Development Association

ALDA

Newsletter published monthly except October covering industry news, legislative/regulatory developments.

Real Estate Development Surveys

Conducted in 1972, 1973, 1977, 1978

and 1979. The 1979 survey discusses sales costs, trends in project characteristics (infrastructure, amenities, size, marketing practices), areas projected for future activities and consumer demand. \$35 for the 1979 survey; \$10 for the others. *Contact: American Land Development Association, 604 Solar Building, 1000 16th St. N.W., Washington, D.C. 20036.*

American Society of Landscape Architects

Landscape Architects Handbook of Professional Practice

Newly revised edition available in September. \$35.

Landscape Architectural Career Information

Information available includes "Landscape Architecture—A Career," "Women in Landscape Architecture" and "List of Accredited Programs in Landscape Architecture." Free.

LATIS, Landscape Architecture Technical Information Series

Monographs available are "Bicycle Planning & Design" (\$5), "Visual Resource Management" (\$5), "Creating Land for Tomorrow" (\$5), "Defensible Processes for Regional Landscape Design" (\$6) and "Controlling Stormwater Impact" (\$10).

A Legacy for Living

Film exploring the vital role of the landscape architectural profession and the involvement of the landscape architect in today's changing world. \$85/\$30 loan.

National Directory of Landscape Architecture Firms

Offers a complete profile of each firm and a geographic listing of each firm's specialty. \$10. Free to contractors of landscape architectural services.

Contact: American Society of Landscape Architects, 1900 M St., Suite 320, Washington, D.C. 20036.

American Underground-Space Association

Analysis and Measurement of the Thermal Behavior of the Walls and Surrounding Soil for a Large Underground Building

Explains how modifications in the thermal regime can best be accomplished. By Paul H. Shipp, George D. Meixel and J. W. Ramsey, \$2.

Analysis of Transient Heat Loss in Earth-Sheltered Structures

Thermal impact of interior and exterior

insulation analyzed with a computer modeling program. By Richard F. Szydlowski and Thomas H. Kuehn. \$2.

The Architectural Underground

Examines historical applications and modern forms and functions of underground buildings. By Kenneth Labs. \$2.

The Barrel Shell—Structural Rethinking in Earth-Sheltered Design

Describes the concepts and techniques of the barrel shell structure. By John B. Langley, AIA. \$2.

City Planning and the Urban Underground

New uses of underground space for relieving urban congestion. By Birger Jansson. \$2.

Climate Responsive Earth-Sheltered Buildings

Offers a methodology for analyzing climate conditions in terms of architectural response required for thermal comfort. By G. Z. Brown and Barbara-Jo Novitski. \$2.

Earth Sheltered Housing Design

Contains plans and sections of 20 earth-sheltered houses. The 318-page report, by the Underground Space Center at the University of Minnesota, discusses the implications of design on energy use, structural needs, waterproofing and other problems. Public policy issues are outlined. \$12.

Earth Sheltering: The Form of Energy and The Energy of Form

An essay by Ed Frenette, FAIA, on current architectural responses to energy conservation introduces 50 award winning and exemplary entries in AUA's 1980-81 underground space design competition. \$18 paperback; \$35 hardcover.

Energy Conservation by Building Underground

Discusses how underground and earth-covered construction saves energy, reduces building costs and preserves valuable land resources. By Thomas P. Bligh. \$2.

The Energy Factor—A Dimension of Design

Discusses factors that determined the choice of an underground building for Williamson Hall, University of Minnesota. By David Bennett and Thomas P. Bligh. \$2.

An Essay—Frequently Asked Questions on Earth-Sheltered Housing

Deals with topics such as site selection, structural systems, energy-use criteria, heating, ventilation and airconditioning, waterproofing, insulation. By Charles Lane. \$2.

Financing Earth-Sheltered Housing: Issues and Opportunities

Examines financial problems and policies. By Mark L. Korell. \$2.

Materials Available Through Other Organizations

"Going Under" Provides a New Industry for Kansas City

Examines the mined space under Kansas City that has been converted into warehouses, factories and offices. By Donna J. Ahrens. \$2.

Going Under to Stay on Top

Increased use of underground space is one example of how energy efficiency and environmental quality can be met simultaneously. By Charles Fairhurst. \$2.

High Bank Instead of High Rise: An Earth-Sheltered Approach to Medium-Density Housing

Suggests that with modern materials and techniques, earth-sheltered residential complexes can utilize steep slopes to ecological and economical advantage. By Gerald W. Thorsen and Roger L. Rue. \$2.

The Impact of Insulation Placement on the Seasonal Heat Loss Through Basement and Earth-Sheltered Walls

Explores several different insulation configurations. By George D. Meixel, Paul H. Shipp and Thomas P. Bligh. \$2.

Insulation Materials and Placement (Earth-Sheltered Structures: Fact Sheet #6)

Covers the advantages, disadvantages and recommendations of the four basic locational choices, selection of insulation type, notes on installation and further references. \$2.

Insulation Principles (Earth-Sheltered Structures: Fact Sheet #5)

Discuss the basic premises governing below grade insulation. \$2.

New Frontiers of Inner Space—Underground

Proposes a formalized segregation of underground space. By J. Gavin Warnock. \$2.

On the Psychology of Earth Covered Buildings

Suggests possible psychological effects. By Paul B. Paulus. \$2.

Passive Energy Design and Habitability Aspects of Earth-Sheltered Housing in Oklahoma

The houses are examined through a detailed questionnaire. By Lester L. Boyer, Walter T. Grondzik and Margaret J. Weber. \$2.

Simplified Design Procedure of Underground Shells

Discussed are maximum values for the earth load, the shape of the shell and the variable thickness distribution. By Jason C. Shih. \$2.

Solar Optics: Light as Energy; Energy as Light

Solar optics, a technique for illuminating

interior spaces with natural light, is explained. By David J. Bennett and David A. Eijadi. \$2.

Structural Systems for Earth-Sheltered Housing

Summarizes the major considerations affecting the selection and design of structural systems for earth-sheltered housing. By Raymond Sterling. \$2.

Studies of Children in an Underground School

Discusses two studies on the effects of an earth-covered school building on pupil achievement, behavior, health and anxiety. By Frank W. Lutz. \$2.

Underground Designs

Plans and illustrations of Malcolm Wells' 18 house designs. \$7.

Underground Plans

Eight different large scale floor plans, sections, elevations and details. Eighty illustrations and information on costs, insulation, structure, waterproofing and landscaping. By Malcolm Wells. \$15.

Underground Space

Bimonthly, international journal that provides multidisciplinary coverage of the technical, legal and social aspects of underground space development.

Waterproofing Techniques (Earth Sheltered Structures: Fact Sheet #3)

Discusses systems, site plans and landscaping, backfillings and drainage and waterproofing skin.

Contact: American Underground-Space Association, Department of Civil and Mineral Engineering, University of Minnesota, Minneapolis, Minn. 55455.

Association for Preservation Technology

APT Bulletin

Quarterly publication contains scientific papers, historical research, book reviews, and reports of preservation technology. Available to members or on a subscription basis.

Communiqué

Bimonthly publication covers the latest news in heritage studies and conservation. \$8.

Conservation and Architectural Restoration: Supply Sources and Brief Bibliographies

Published in 1978. \$3.

Paint Color Research and Restoration of Historic Paint

Published in 1977. \$3.

Russell Erwin Manufacturing Co. Illustrated Catalogue of American Hardware

The 450-page book contains information on virtually every article of American hardware manufactured in the U.S. in

1865, with an introduction by Lee H. Nelson, AIA. \$14.95.

Simplified Reproduction of Wood Moldings

Published in 1976. 75 cents.

Contact: Association for Preservation Technology, Box 2487, Station D, Ottawa, Ontario K1P 5W6, Canada.

Associated General Contractors of America

The Basic Bond Book

Intended to simplify the subject of contract bonding. \$6.

Construction Management Control Process

Outline of the normal process to be followed on a construction management project. The booklet charts and describes the responsibility of owner, architect and construction manager. \$10.

Construction Management for the General Contractor

Guide manual for construction in which six general contractors explain how their firms perform various aspects of construction management from the signing of the contract to the physical completion of the project. \$19.95.

Constructor Publications Library

Brochure lists all the publications available from AGC. Free.

Energy Conservation Guidelines

Contains more than 20 specific suggestions for energy conservation. \$3.75 per dozen.

First Budget Estimate Guideline

Provides a method to arrive at the first estimate of a project still in the conceptual stages of development. \$2.50.

Guide to Owner Responsibility for Construction Projects

Explains the workings of a construction contract—lump sum, cost plus a guaranteed maximum, straight cost plus a fee or construction management. \$7.50 per dozen.

Manual of Accident Prevention in Construction

Contains recommended safe practices on construction work. \$10.

Pre-Qualification Statement for Building Construction

Used to indicate the contractor's experience and work currently underway to enable the architect and/or owner to pre-qualify the contractor prior to bidding. \$1.25.

continued on page 114

Tear out.

SOLAR HEATING SYSTEMS: Analysis and Design with the Sun-Pulse Method by Gordon F. Tully. Myth-shattering, detailed how-to on the overall design, behavior, and troubleshooting of systems — without oversimplification or complex math. (065441-7) \$23.95

SOLAR ARCHITECTURE: The Direct Gain Approach by Timothy E. Johnson. Design for maximum thermal, visual, and esthetic comfort in residential buildings of all types using the latest in passive solar heating technology and construction materials. Integrates site design, daylighting, glare control, layout, and more. (032598-7) \$21.50 (tent.)

JAPANESE GARDENS: Design and Meaning by M. Bring and J. Wayembergh. Looking for fresh visual and spatial design ideas? Turn to this lavishly illustrated, revealing analysis of the structure and standards of this classic landscaping artform. (007825-4) \$19.95

LIFE CYCLE COSTING FOR DESIGN PROFESSIONALS by A. J. Dell'Isola and S. J. Kirk. Boost commissions by saving money at every phase of a building project — and over its entire life — with this total cost/performance monitoring and problem-solving methodology. (016280-8) \$24.95

DAYLIGHT IN ARCHITECTURE by Benjamin H. Evans. Creative, functional ways to integrate the open sky into your total building designs to enhance mood, improve seeing conditions, and save on energy costs. (019768-7) \$29.95

CONTEMPORARY CLASSICS: Furniture of the Masters by C. Gandy and S. Zimmermann-Stidham. The *crème de la crème* of modern furniture designs: their dimensions, specs, materials, engineering, construction, and their creators (nearly all of them architects!). (022760-8) \$19.95

REHABBING FOR PROFIT by Jerry Davis. All the ins and outs of how to select, finance, rehabilitate, manage, or resell buildings of from one to six units — without a lot of starting capital! (015695-6) \$17.50

ENTOURAGE: A Tracing File for Architecture and Interior Design Drawings by Ernest Burden. A comprehensive time- and effort-saving collection of over 3,000 high-quality, completely reducible tracings of people, cars, trees, etc. in all sizes, combinations, and perspectives. Pages removable for easy use. (008930-2) \$15.95

SYSTEMS DRAFTING: Creative Reprographics for Architects and Engineers by Fred A. Stitt. Save 20 to 50% of your current drawing and drafting costs — and improve design quality — by creating an office system that uses the latest drawing production methods and eliminates repetitive drafting chores. (061550-0) \$19.95

GENTLE ARCHITECTURE by Malcolm Wells. How architecture can reclaim ruined land, solve problems not create them. Factual information on economically viable, ecologically sound options for saving energy and protecting the environment that are available to every architect. (069245-9) \$22.50

RECREATION PLANNING AND DESIGN by Seymour M. Gold. To help you make the most of the urgent demand for parks and outdoor recreation spaces, here's a wealth of how-to information on planning, designing, and implementing them. With many real-life examples of successful projects of all types and sizes. (023644-5) \$27.50

THE ARCHITECT'S GUIDE TO ENERGY CONSERVATION: Realistic Energy Planning for Buildings by Seymour Jarmul. Turns the current deluge of energy-saving advice into a practical working tool by focusing on down-to-earth, budget-fitting design features and installation techniques that require no special training. (032296-1) \$18.50

SOLAR ENERGY HANDBOOK edited by Jan F. Kreider and Frank Kreith. The first single, up-to-date volume to comprehensively treat *all* aspects of the field — from basic principles and design criteria to the architectural, legal, and economic ramifications of solar energy conversion. (035474-X) \$49.50

DESIGN OF WOOD STRUCTURES by D. E. Breyer and J. A. Ank. Based on the latest code criteria, this first *complete* guide to wood frame design provides time- and money-saving shortcuts, new materials and applications, scores of practical examples, and a wide range of design dos and don'ts. (007671-5) \$27.50

BUILDING SYSTEMS DESIGN WITH PROGRAMMABLE CALCULATORS by Sital Daryanani. Turn your TI-59 or HP-97 calculator into your own personal design computer with these 22 easy-to-use programs for designing lighting systems, heating and cooling ductwork, plumbing systems — even solar energy installations — in a fraction of the usual time. (015415-5) \$29.50

Mail entire page to:

McGraw-Hill Book Company • 1221 Avenue of the Americas • New York, NY 10020
Att: John J. Stockwell

Please send me the book(s) I have checked off for 15 days' FREE examination. At the end of that time, I will pay in full, plus local tax, postage, and handling, or return the book(s) postpaid without further obligation.

ALSO send me the next two issues of LEGAL BRIEFS FOR THE CONSTRUCTION INDUSTRY so that I may evaluate them for myself. After receiving the *free* issues, I will either approve the invoice sent with them and receive 24 issues (a year's subscription) for \$97.00, or I will write "cancel" on the invoice, return it to McGraw-Hill, be under no further obligation.

Name _____

Address _____ Apt. _____

City _____ State _____ Zip _____

Offer good only in U.S. Order subject to acceptance by McGraw-Hill.

Check one: VISA MasterCard M/C Bank # _____

Credit Card # _____ Expiration Date _____

SAVE MONEY: If you remit in full, plus local tax, with this order, McGraw-Hill will pay all regular postage and handling costs. Same refund privilege applies.

23-F-645-4076-3

Now — avoid legal problems — prevent expensive settlements!

LEGAL BRIEFS FOR THE CONSTRUCTION INDUSTRY

A quick-reading review of significant rulings, decisions, and case law for everyone in the building profession. Designed especially for the nonlegal reader, these twice monthly reports form an "early warning system" that helps you protect your business — and yourself. Remember: win or lose, a lawsuit can cost you plenty.

Read the next two issues FREE — without obligation



And mail!

Put page after page of new ideas
and practical applications to work
on the job — FREE — for 15 days!

Circle 37 on information card

Other Organizations from page 112

Private Work: Managing the Risks

Guide to ascertain the financial capability of a project owner to fulfill his obligations under the contract for construction. \$2.50.

Recommended Guide for Bidding Procedures and Contract Awards for Building Construction

Guide for presenting bids to owners or architects. \$1.80.

A Suggested Guide and Checklist for Subcontractors

Explains the functions and responsibilities for work assignments and payments. 25 cents.

The Use of CPM in Construction

Gives a history of the critical path method and describes its use and values to contractors. \$10.

Contact: Publications Department, Associated General Contractors of America, 1957 E St. N.W., Washington, D.C. 20006.

Center for Building Technology, National Bureau of Standards

Building Technology Project Summaries, 1979-1980

Covers the center's research projects that are meant to advance building technology. Topics include energy conservation in buildings, building thermal envelope systems and insulating materials, building solar systems technology, earthquake hazard reduction, structures and foundations performance, building safety, building rehabilitation technology, building and community acoustics, buildings service systems performance, lighting technology and building economics.

Building Technology Publications Supplement 4: 1979

Lists titles with abstracts of each NBS publication.

Center for Building Technology: A Perspective—1979

Presents an overview of the center's research, its accomplishments and on-going projects.

Research News

Newsletter covering the center's research, publications, events and resources.

Contact: Center for Building Technology, National Bureau of Standards, U.S. Department of Commerce, Washington, D.C. 20234.

Center for Fire Research, National Bureau of Standards

Fire Research Publications, 1980

Lists publications prepared by the center, by other National Bureau of Standards personnel or by others under contract or grant from CFR.

Fireview

Covers fire problems and solutions.

Contact: Center for Fire Research, National Bureau of Standards, U.S. Department of Commerce, Washington, D.C. 20234.

Cooperative Preservation Of Architectural Records, Library of Congress

Architectural Records in Chicago: A Guide to Architectural Research Resources in Cook County and Vicinity

Published by the Art Institute of Chicago, 1981. \$14.95.

Architectural Research Materials in New York City: A Guide to Resources in All Five Boroughs

Published by the Committee for the Preservation of Architectural Records, 1977.

Architectural Research Materials in Philadelphia

Published by the Committee for the Preservation of Architectural Records.

Directory of Historic American Architectural Firms

Edited by Sheila Burns Thomes; published by AIA and the Committee for Preservation of Architectural Records, 1979. \$3.

Newsletter for COPAR

Published quarterly by the Library of Congress about the Cooperative Preservation of Architectural Records.

A Preliminary Checklist of the Records of Pre-1970 Architectural Firms of Greater Boston

Edited by Nancy Carlson Schrock; published by the Massachusetts Committee for the Preservation of Architectural Records, 1980. \$1.25.

Records in Architectural Offices: Suggestions for the Proper Organization, Storage and Conservation of Architectural Office Archives

Published by the Massachusetts Committee for the Preservation of Architectural Records, 1980. \$1.25.

Services

Offers guidelines for the formation of local and state groups who wish to preserve architectural records. It also maintains the data for a national union catalog of architectural records and provides information about them.

Contact: Cooperative Preservation of Architectural Records, Prints & Photographs Division, Library of Congress, Washington, D.C. 20540.

Earthquake Engineering Research Institute

Bibliography of Earthquake Engineering

Gives references to books, periodicals, papers, maps and conference proceedings on earthquake topics: seismic geology, seismology, seismometry; dynamics of soil, rocks and structures, and design and construction in seismic regions. Compiled by E. P. Hollis. \$5.

Introduction to Dynamics of Structures

Monograph by A. K. Chopra. \$7.

Learning from Earthquakes

A 1977 planning and field guide is available (\$7), as well as a 1973-79 project report (\$7).

Reading and Interpreting Strong Motion Accelerograms

Provides the nonspecialist in strong motion earthquake instrumentation and data processing the basic knowledge needed to appreciate the information contained in typical accelerograms. \$7.

Reconnaissance Reports

11 earthquakes and the damages caused are examined. U.S. earthquakes studies are those occurring in Northern Kentucky, July 27, 1980; Imperial County, Calif., Oct. 15, 1979, and Santa Barbara, Aug. 13, 1978. Prices vary from \$5 to \$10.

Soil and Structure Response to Earthquakes

Videotaped lecture series in four sessions covers understanding and predicting soil behavior, introduction to structural dynamics, understanding and predicting structural behavior and soil-structure interaction. \$50 for the set of four; \$15 for individual lectures.

Contact: Earthquake Engineering Research Institute, 2620 Telegraph Ave., Berkeley, Calif. 94704.

Environmental Design Research Association, Inc.

Conference Publications

EDRA 1/1969 (\$20)

EDRA 2/1970 (\$27)

EDRA 4/1973, Environmental Design Research Vol. 1: Selected Papers (\$27.50) and Vol. 2: Symposia and Workshops (\$27.50).

EDRA 5/1974, Man-Environment Interactions: Evaluations and Applications (60). *continued on page 116*



Bigelow does more than just manufacture this carpet

- ✓ We select the proper fiber, engineer the correct yarn system and then construct the carpet for its specific end use requirement.
- ✓ We design patterns, solids and textures based on today's unique commercial carpet applications.
- ✓ Rigid quality control assures you of uniform quality throughout Bigelow's entire commercial line.
- ✓ Our staff of installation professionals provide expert instruction or counselling for completing each job in the most efficient and trouble-free manner.
- ✓ We offer the broadest selection of tufted, woven and modular tile commercial carpets, in more colors, than any other manufacturer in the industry.
- ✓ The Bigelow team of engineering and research professionals combine to offer state-of-the-art carpet manufacturing technology that is second to none.

Unique services, product choice plus proven performance make Bigelow First in Contract Carpet.

This Bigelow Contract Carpet was created for the Americana Hotel, Tandy Center, Fort Worth, Texas, of DuPont Antron® III nylon with static control.

DUPONT
Antron III
DUPONT



Bigelow

Bigelow-Sanford, Inc., P.O. Box 3089, Greenville, S.C. 29602. 803-299-2000

Circle 38 on information card

Other Organizations from page 114

- EDRA 6/1975, Responding to Social Change (\$22).
- EDRA 7/1976, The Behavioral Basis of Design, Book I: Selected Papers (\$30) and Book II: Session Summaries and Papers (\$30).
- EDRA 8/1977, Priorities for Environmental Design Research, Part 1: Selected Papers (\$25) and Part 2: Workshop Summaries (\$25).
- EDRA 10/1979, Environmental Design: Research, Theory and Application (\$25).
- EDRA 11/1980, Optimizing Environments: Research, Practice and Policy (\$26).
- EDRA 12/1981, Design Research Interactions (\$30).

Design Research News

Bimonthly newsletter covering research and projects in progress, research briefs, new publications, meetings, among other things.

Contact: *Environmental Design Research Association, Inc., L'Enfant Plaza Station, P.O. Box 23129, Washington, D.C. 20024.*

International Solar Energy Society, Inc., The American Section

Proceedings of Annual Meetings

- Sharing the Sun: Proceedings of the 1976 Joint Annual Meeting of the American Section of the International Solar Energy Society, Inc. (AS of ISES) and Solar Energy Society of Canada. \$250.
- Solar Diversification: Proceedings of the 1978 Annual Meeting. \$95.
- Solar Energy Symposia: 1978 Annual Meeting. \$22.50.
- A Solar World: Proceedings of the 1977 Annual Meeting. \$95.
- SUN II: Proceedings of the 1979 Joint Annual Meeting of AS of ISES and ISES. \$325.
- To Will One Thing: Solar Action at the Local Level. \$25.
- Tutorials: 1978 Annual Meeting. \$15.
- Twenty-five Years of the Sun at Work: Proceedings of the 1980 Annual Meeting. \$125.
- Proceedings of Topical Division Conferences and Workshops**
- Fifth National Passive Solar Conference Proceedings. \$125.

- Fourth National Passive Solar Conference Proceedings. \$65.
- Monitoring Solar Heating and Cooling Passive Systems '78. \$30.
- Proceedings of the First Workshop on the Control of Solar Energy Systems for Heating and Cooling. \$22.50.
- Proceedings of the Second Annual Conference on Wind Power: Energy Alternative for the Midwest.
- Proceedings of the Third Workshop on the Use of Solar Energy for the Cooling of Buildings. \$30.
- Second National Passive Solar Conference Proceedings. \$50.
- Third National Passive Solar Conference Proceedings. \$65.
- Solar Energy Technology Handbook**
- Part A discusses engineering fundamentals and working formulas. Part B focuses on application of technologies covered in Part A as well as the economics of solar systems, the barriers to and incentives for commercialization and the environmental, health and safety issues involved in the use of solar energy. Each volume \$85; two-volume set \$165.
- Contact: *American Section, International Solar Energy Society, Inc., c/o the Research Institute for Advanced Technology, U.S. Highway 190 West, Killeen, Tex. 76541.*

International Union of Architects

Architects in Intertropical Africa

Lomé, Togo, seminar, 1974; in French or English.

Basic Housing—Case Studies

Discusses the design of low-cost housing and community facilities, Volume II, 1976; in English.

The Economic Future of the Architect

Published in 1978 in English and French.

Graphic Representation of Town Planning Design

Published in 1976 in French.

Informations, UIA

Monthly newsletter published in English, French and Spanish.

International Charter for Habitat

In French, English, Spanish, Russian, 1976.

International Seminar on the Continuing Education of Architects

Published in 1977 in French and English.

Madrid International Competition on the Training of Architects

Study of six world reports.

On the Training of Town Planners

Synthesis of meeting held in Chandigarh, India, at the invitation of UNESCO, 1977; in French and English.

Proceedings of the Fourth Seminar on Self-Reliance on Educational Facilities

Held in Dakar, Senegal, in 1978; in French and English.

Proceedings of the Second Seminar on Flexibility of Buildings for Education

Held in Berlin in 1974; in English.

Proceedings of the UIA Seminar on Community Participation in Comprehensive Facilities

Held in Washington, D.C., in 1979; in French and English.

Riyadh International Competition UIA Seminar on Integration of Educational and Community Facilities

Proceedings of Athens seminar, 1976; in French and English.

Contact: *Union Internationale des Architectes, 51, rue Raynouard 75016 Paris, France.*

Mortgage Bankers Association of America

Mortgage Banker

Monthly magazine covering all aspects of the economy, mortgage markets, government regulations, mortgage banking operations, trends and industry news. One-year subscription, \$20.

Mortgage Banking in the 1980s

Reprint from *Mortgage Banker* magazine providing an in-depth look at the economic and demographic trends affecting the mortgage market, plus the outlook for construction and mortgage banking in the '80s. \$1.

Mortgage Banking Terms—A Working Glossary

Compendium of more than 750 terms used in day-to-day practice of mortgage banking. \$5.

Weathervane

Monthly economic report with commentary and forecasts of financial and mortgage market conditions. Free.

Contact: *Publications Department, Mortgage Bankers Association of America, 1125 15th St. N.W., Washington, D.C. 20005.*

National Architectural and Engineering Record, U.S. Department of the Interior

Catalogs of the Historic American Buildings Survey

Catalog of the Measured Drawings and Photographs of the Survey in the Library of Congress, 1941. \$24.

Catalog Supplement, Catalog of the Measured Drawings and Photographs

continued on page 118

PLEXIGLAS® DR®



for rugged lighting lenses in public access areas

“When we design lighting for public access areas, we want lenses that will stand up to vandalism and rough handling during installation and maintenance. We also want to provide our clients many years of lens service without discoloring or loss of physical properties. On our Philadelphia Parking Authority Airport Garage project, Plexiglas DR met these design criteria at an attractive price.”

Jack A. Thalheimer, AIA,
Thalheimer & Weitz,
Architects and Engineers
Philadelphia, PA

Plexiglas DR is a high-impact acrylic lighting lens material that offers a long service life, indoors or out.

It achieves its longevity through an outstanding ability to resist yellowing and degradation from exposure to the elements and ultraviolet rays.

You might consider using polycarbonate; however, Plexiglas DR costs far less and maintains its excellent light-transmitting characteristics far longer.

For complete information on this affordable lens material that provides all the impact strength you'll probably need, and will continue to look good for years, circle the Reader Service Card number or write:
Rohm and Haas Company, Independence Mall West, Philadelphia, PA 19105, Attn: Marketing Services Department.

Plexiglas acrylic plastic is a combustible thermoplastic. Observe fire precautions appropriate for comparable forms of wood. For building uses, check code approvals. Impact resistance a factor of thickness. Avoid exposure to heat or aromatic solvents. Clean with soap and water. Avoid abrasives.

the trademark

**PLEXIGLAS
DR**

the company

**ROHM
&
HAAS** 
PHILADELPHIA, PA 19105

In Canada, West Hill, Ontario MIE 3T9

PLEXIGLAS® DR® / Where Extra Toughness Counts

Circle 39 on information card

Other Organizations from page 116

- of the Survey in the Library of Congress, Comprising Additions Since March 1, 1941. \$12.
District of Columbia Catalog, 1974. \$9.75 hardcover; \$3.50 paperback.
Chicago and Nearby Illinois Areas, 1966. \$2.
Iowa Catalog, 1979. \$12.50 hardcover; \$8.95.
Maine Catalog, 1974. \$8.95.
New Hampshire Catalog, 1963. \$2.75.
New Jersey Catalog, 1977. \$13.95 hardcover; \$9.95 paperback.
Philadelphia Preserved, 1976. \$20.
Texas Catalog, 1974. \$5.
Virginia Catalog, 1976. \$20 hardcover; \$6.95 paperback.

Historic American Buildings Survey
Brochure detailing the responsibilities of the organization.

Historic American Engineering Record
Brochure detailing the responsibilities of the organization.

Measured Drawings of National Trust Properties

Drawings available for Belle Grove, Va.; Casa Amesti, Calif.; Cliveden, Pa.; Decatur house, Washington, D.C.; Lyndhurst, N.Y.; Pope-Leighy house, Va., and Shadows-on-the-Teche, La. \$2.75 each; \$17.50 folio.

Measured Drawings of Northern Illinois Architecture

Three volumes. \$5.25 each.

National Architectural and Engineering Record

Briefly discusses the history and programs of the NAER.

Publications Based Primarily on Historical American Building Survey Records

Architecture of Middle Tennessee. \$17.95.

An Enduring Heritage. \$18.75.

Historic Buildings of Massachusetts. \$14.95.

Historic Buildings of Ohio. \$20 hardcover; \$7.95 paperback.

Historic Buildings of Washington, D.C. \$20 hardcover; \$7.95 paperback.

Rehabilitation Publications

An Alternative for Historic Industrial Buildings. \$4.

Claremont 1978: Planning for Adaptive Use and Energy Conservation in an Historic Mill Village. \$3.75.

Danville 1978: A Strategy for Building Reuse and Neighborhood Conservation. \$3.75.

Fairmount Waterworks 1978: Conservation and Recreation in a National Historic Landmark. \$2.25.

Topical Publications

An Architectural Study of Fort McHenry. \$9.

The Cape May Handbook
Historic Architecture of the Virgin Islands. \$7.25.

What Style Is It?

By John Poppeliers, S. Allen Chambers and Nancy B. Schwartz. \$3.50.

Contact: *National Architectural and Engineering Record, the National Park Service, U.S. Department of the Interior, Washington, D.C. 20204.*

National Housing Rehabilitation Association

Recycling Real Estate

Monthly newsletter updates changes in federal rehab programs and gives examples of how to tap the expertise and resources of the private sector to solve rehab problems. One-year subscription, \$135.

Contact: *National Housing Rehabilitation Association, Suite 310, 1300 19th St. N.W., Washington, D.C. 20036.*

National Society Of Professional Engineers

Public Relations & The Engineer

Videotape exploring how to launch a public relations program. It includes a discussion of tools, vehicles, plans and methods. \$100.

Contact: *National Society of Professional Engineers, 2029 K St. N.W., Washington, D.C. 20006.*

National Trust For Historic Preservation

Conserve Neighborhoods

Newsletter on neighborhood conservation. Free subscription to neighborhood groups; \$2.50 for others.

Film Catalog

A listing of films is available. Free.

Historic Preservation

Bimonthly magazine available to National Trust members.

Information Sheets

A list of topics and ordering information is available. Free.

Network Alert

Legislative fact sheet. Free.

Photographs and slides

Can be borrowed from the National Trust collection.

Preservation News

Monthly newspaper available to National Trust members.

Contact: *National Trust for Historic Preservation, 1785 Massachusetts Ave. N.W., Washington, D.C. 20036.*

Royal Australian Institute of Architects

Architecture Australia

Magazine published six times a year. \$21.

Audiovisual Materials

Brickwork Growth: A Differential Movement

Designing for Disabled Persons

Mastics and Sealants

The Migration of Architectural Ideas

Modern Mannerisms in American Architecture: Post Modernism in the United States

The National Archives Competition
Nationalism and Fugality: The Office of Edmon and Corrigan

New Uses for Old Buildings

The Parliament House Competition

Passive Solar Design I: Introduction

Passive Solar Design II: Thermal Isolation/Insulation

Passive Solar Design III: Passive Solar Heating

Passive Solar Design IV: Passive Solar Cooling and Shading

Passive Solar Design V: Some Passive Solar Houses in Australia

Practical Sound Control: Common Problems in Buildings

Precast Concrete Cladding Panels: General Practice and Problems

Rain Penetration of Buildings

Restoration II: Roofing

Restoration III: Masonry Walls

Restoration IV: Timber Frames

Restoration V: Joinery

Roofing Problems

Work in the Mainstream of Modern Architectural Development—Harry Seidler

The Work of Ancher, Mortlock and Woolley

The Work of Cameron, Chisholm and Nicol

The Work of Charles Moore

The Work of Daryl Jackson

The Work of McConnel Smith and Johnson

The Work of Morris and Pirrotta

The Work of Philip Cox

The Work of Rob Nation

Contact: *Bookshop, Royal Australian Institute of Architects, 2A Mugga Way, Red Hill, A.C.T., P.O. Box 373, Manuka, A.C.T. 2603, Australia.*

Society of Architectural Historians

The Cape Cod House: An Introductory Study

By Ernest Allen Connally. \$1.50.

Guidebooks (listed by state or region)

Alabama: Downtown Birmingham:

Architectural and Historical Walking Tour Guide, edited by Marjorie Longenecker White. \$8.

Nineteenth Century Mobile Architecture: An Inventory of Existing Buildings, Mobile City Planning Commission. \$5.

California: A Guide to Architecture in Los Angeles and Southern California, by David Gebhard and Robert Winter. \$14.20.

A Guide to Architecture in San Francisco and Northern California, by David Gebhard, et. al. \$11.20.

The Sidewalk Companion to Santa Cruz Architecture, by John Chase. \$11.20.

Colorado: Denver Landmarks, by Langdon E. Morris Jr. \$11.20.

Connecticut: New Haven: A Guide to Architecture and Urban Design, by Elizabeth Mills Brown. \$6.95.

Norwich, Connecticut: A Guide to its Architecture, by Stephen Harby. \$3.95.

District of Columbia: A Guide to the Architecture of Washington, D.C., by Warren J. Cox, et. al. \$7.95.

Walking Tours: Washington, D.C., by Tony P. Wrenn. \$2.

Washington on Foot, edited by Allan A. Hodges and Carol A. Hodges. \$5.25.

Idaho: Saints and Oddfellows: A Bicentennial Sampler of Idaho Architecture, by J. Meredith Neil. \$4.95.

Illinois: Chicago's Famous Buildings, edited by Ira J. Bach. \$5.95.

Indiana: Indianapolis Architecture, Indiana Architectural Foundation. \$8.20.

Iowa: The Prairie School in Iowa, by Richard Guy Wilson and Sidney K. Robinson. \$8.75.

Maryland: The Building of Westminster, by Christopher Weeks. \$7.95.

Inventory of Historic Sites in Calvert County, Charles County and St. Mary's County. \$12.20.

Massachusetts: Houses of Boston's Back Bay: An Architectural History, 1840-1917, by Bainbridge Bunting. \$11.25.

Victorian Boston Today: Ten Walking Tours, edited by Pauline Chase Harrell and Margaret Supplee Smith. \$4.95.

Minnesota: A Guide to the Architecture of Minnesota, by David Gebhard and Tom Martinson. \$12.20.

Mississippi: The Building of Biloxi: An Architectural Survey, by Julia Cook, et al. \$6.25.

New England: Exploring Coastal New England: Gloucester to Kennebecport, by Barbara Clayton and Kathleen Whitley. \$8.20.

New Hampshire: New Hampshire Architecture: An Illustrated Guide, by Bryant F. Tolles Jr., with Carolyn K. Tolles. \$8.75.

New Mexico: New Mexico Architecture, by Bainbridge Bunting and John Conron. \$1.50.

New York: The City Observed: New York, by Paul Goldberger. \$9.20.

Landmarks of Otsego County, by Diantha Dow Schull. \$11.20.

Of Town and the River: A Rochester Guide, by Jean France and Betsy Brayer. \$6.95.

Ohio: Landmark Architecture of Cleveland, by Mary-Peale Schofield. \$5.95.

Pennsylvania: Fairmount Park: A History and a Guidebook, by Esther M. Klein. \$4.

Lancaster Architecture, 1719-1927: A Guide to Publicly Accessible Buildings in Lancaster County, by John J. Snyder Jr. \$3.50.

Rhode Island: Newport: A Tour Guide, by Anne Randall and Robert P. Foley. \$4.95.

Texas: San Antonio: A Historical and Pictorial Guide, by Charles Ramsdell. \$5.95.

Washington: A Guide to Architecture in Washington State, by Sally B. Woodbridge and Roger Montgomery. \$14.20.

Foreign: Europe Architectural Guide, 1860-Today, by Jeryll Habegger. \$5.50.

Exploring Vancouver 2: Ten Tours of the City and Its Buildings, by Harold Kalman. \$9.20.

Victoria: A Primer for Regional History in Architecture 1843-1929, by Martin Segger and Douglas Franklin. \$12.25.

Historical American Buildings Survey Catalogs

Offered are: Iowa Catalog (\$9.95), Historic Architecture of Maine (\$10.25), Historic American Buildings Survey of New Jersey (\$10.95) and Texas Catalog (\$6.20).

Journal of the Society of Architectural Historians and Newsletter.

Available to members.

SAH Placement Service Bulletin

Lists academic positions available in architecture. Free.

Contact: Society of Architectural Historians, 1700 Walnut St., Suite 716, Philadelphia, Pa. 19103.

Society for Marketing Professional Services

The Marketing Coordinator

Report explaining the role of the marketing director and the marketing department in an architectural firm. \$10.

Marketing Salary and Expense Survey, 1980

Information for the management of an A/E firm's marketing effort. Presents in-depth analysis of salary data and expense data. \$25.

Proposal Preparation

Suggestions for any written presentation that will bring an architectural firm "closer to selection." \$10.

SMPSnews

Monthly newsletter available to members.

Standard Forms 254 and 255

Explains federal procurement for architectural and engineering services. \$10.

Contact: Society for Marketing Professional Services, 1437 Pawhatan St., Alexandria, Va. 22314.

Urban Land Institute

Audiovisual material:

Slide/sound programs discuss "A New Approach to Erosion and Sediment Control" (\$35), "A New Approach to Storm Water Management" (\$25) and "A New Approach to Residential Street" (\$25).

Environment Comment

Magazine published 12 times a year covering environmental legislation and issues. Available to members only.

Project Reference File

Technical reports covering U.S. and Canadian projects—site plans, economic data, statistics, successes and failures. Twenty projects are covered each year. Single copies, \$3.50. One year subscription, \$60; two years, \$100; three years, \$145.

Publications Catalog, 1981

Describes the more than 100 publications available. Topics include finance and tax, growth management, industrial development, new communities, office and commercial, open space in development, planned unit development, recreational development, residential development, shopping centers, urban development and urban redevelopment. Free.

Urban Land

Magazine published 11 times a year covering land use planning and development topics. Available to members only.

Contact: Urban Land Institute, 1090 Vermont Ave. N.W., Washington, D.C. 20005.

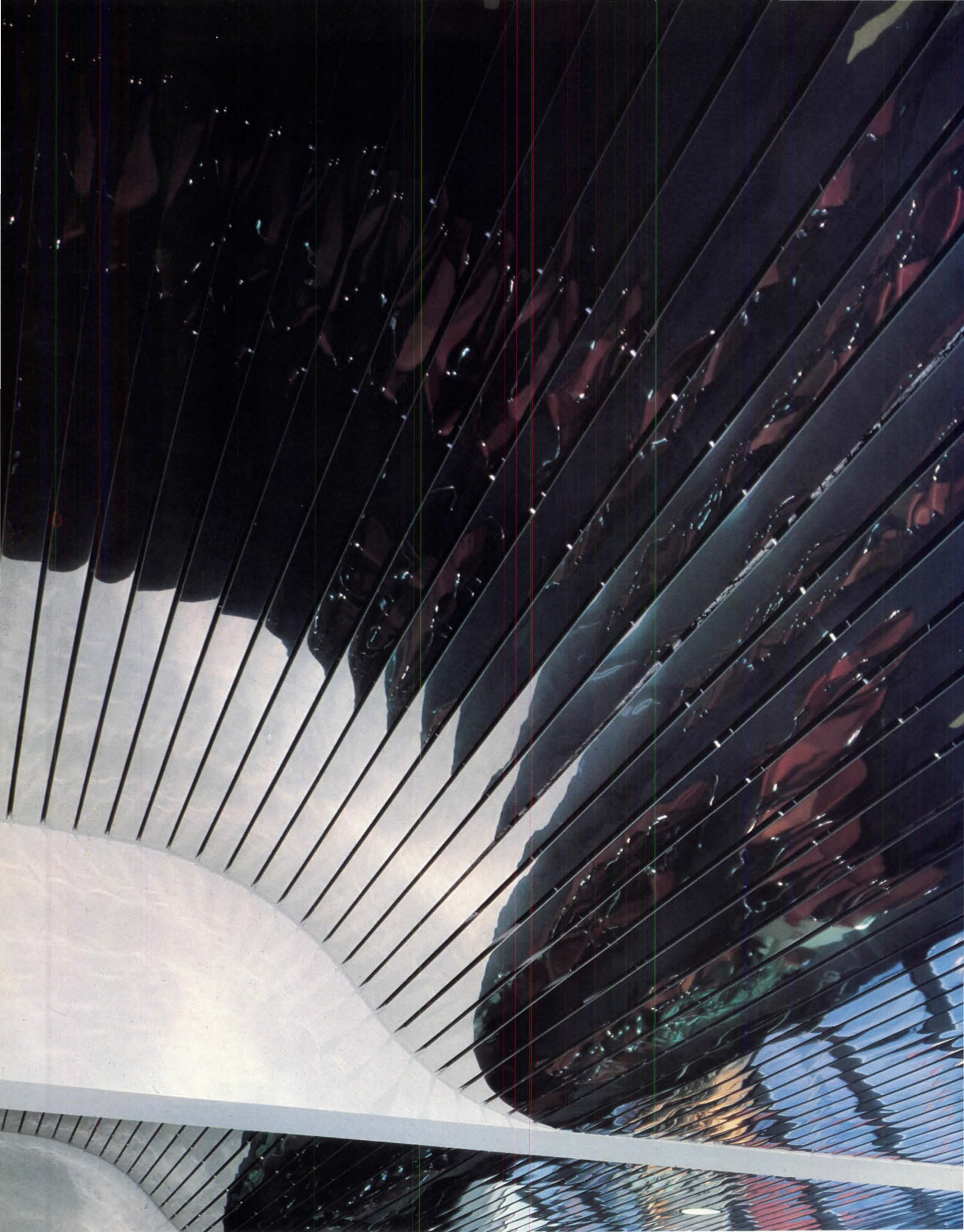

The Metropolitan Oakland International Airport, Architects: VBN Corporation, Oakland, CA

The imagination, colors and quality you expect from Levolor Ceiling System



CEILINGS BY LEVOLOR®
DAEMPÄ CEILING SYSTEMS/ECOL-O-VANĚ CEILING SYSTEMS

For details, write: Ceilings by Levolor, Levolor Lorentenzen, Inc., 1280 Wall Street West, Lyndhurst, New Jersey 07071.

Circle 40 on information card

These publications may be ordered from the AIA Department of Publications Marketing/Sales, 1735 New York Ave. N.W., Washington, D.C. 20006, (202) 626-7475. Include name of person to receive order, quantity, title, catalog number(s) and payment (check payable to AIA). *Indicates books published by organizations other than AIA and that may not be in accord with AIA policy. The cost of each book is indicated as AIA members' price/nonmembers' price.

A

AIA Building Construction Legal Citator, 1980 Edition (2M119)

Compiled under the direction of Spencer, Whalen & Graham of the D.C. bar, this updated edition has been improved for easy reference and to speed research. Volume 2 of the two-volume set contains the current edition plus all earlier editions of each form, reproduced in their entirety. Volume 1 of the set contains comprehensive, accurate and authoritative information on court decisions in all U.S. jurisdictions relating to the standard contract forms of AIA, and a complete cross-reference of the forms in volume 2. Two-volume loose-leaf binders. \$64/\$80.

***AIA Guide to New York City (3M383)** 653-page, revised edition (1978) by Norval White, FAIA, and Elliot Willensky, AIA, includes a short introduction and a capsule description of each of the five boroughs. Comments on shops, restaurants, theaters, parks, squares and buildings of historical and architectural interest. Paperback, \$11.75/\$12.95.

***AIA Guide to the Architecture of Washington, D.C. (3M269)**

Revised edition (1974) of the convention guidebook prepared by the Washington Metropolitan Chapter/AIA. The 246-page working guide is arranged into convenient walking and motoring tours. Paperback, \$6.25/\$6.95.

AIA Membership Directory (4M136)

Annual alphabetical listing of all AIA members and associates, including addresses and chapter affiliations. Appendices include honorary members and fellows, component presidents, medals and awards, affiliated and associated organizations. \$15/\$75.

***AIA Metric Building and Construction Guide (3M426)**

Edited for AIA by Susan Braybrooke, the 154-page primer (1980) provides information on the International System of Measurement (SI) as applied to build-

ing construction. Includes detailed drawings, charts, conversion tables and conversion factors. \$20.75/\$23. Paperback, (3M426P) \$15.75/\$17.25.

AIA Tote Bag (4M419)

American Institute of Architects in bold black letters with AIA emblem on off-white heavy-duty washable canvas bag. Size: 9½ x 13½ x 4½. \$6.

***Alternative Natural Energy Sources in Building Design (3M323)**

Alternative energy solutions to many energy design problems are discussed in this 215-page book (1977) by Albert Davis and Robert Schubert—through diagrams, tables and formulas. Paperback, \$7.25/\$7.95.

American Endless Weekend (2M151)

64-page publication (1973) by C. Ray Smith, AIA, that looks into recreation problems and planning in America. Prepared for the AIA committee on architecture for the arts and recreation. \$5/\$6.

***Anatomy of a Park: The Essentials of Recreation Area Planning and Design (3M126)**

192-page "nontechnical" technical book (1971) by Albert J. Rutledge, presenting a system for evaluating the worth of a park design plan and a view of design criteria based upon behavioral science findings relating to people's needs—both esthetic and functional. \$29.25/\$32.50.

Annual of American Architecture, 1980 (2M725)

Available for the first time in hardcover, this 120-page annual survey features significant architecture in America in 1979. Taken directly from the editorial portion of the 1980 Mid-May issue of the AIA JOURNAL, it includes homes, factories, churches, etc. \$16/\$19.95.

Annual of American Architecture, 1981 (2M731)

Features significant American architecture of 1980, as determined by the editors of the AIA JOURNAL. Includes many state and regional award-winning buildings. 168 editorial pages taken directly from the 1981 Mid-May issue of the JOURNAL. \$20/\$24.95.

***The Architect as Developer (3M235)**

202-page book (1976) by John Portman, FAIA, and Jonathan Barnett, AIA, examines architectural and financial advantages of integrating real estate development and architectural design into a single process. Includes case study of Peachtree Center Plaza Hotel from conception to completion. \$31.50/\$34.95.

Architect/Engineer Government Contracting: A Manual (4M718)

In loose-leaf format, this convenient, easy-to-read manual (1979) contains actual forms, documents, regulations, laws,

guidelines and techniques used by public officials and design practitioners in A/E contracting. Prepared by the Committee on Federal Procurement of A/E Services, it is available for the first time outside the successful contracting course. \$95.

***The Architect's Guide to Energy Conservation (3M500)**

Written by Seymour Jarmul, AIA, this 256-page volume (1980) emphasizes realistic techniques that also fit within realistic construction budgets and that can be installed by the building trades without special training. \$19.50/\$21.50.

Architect's Guide to Facility Programming (2M726)

293-page book (1981) by Mickey Palmer examines contemporary programming in architecture, including the architect's role, the process, techniques, tools, applications (via case studies) and opportunities. \$28/\$34.95.

Architect's Guide to International Practice (2M715)

107-page guide (1978) contains pertinent facts on 29 foreign countries, acquainting architects with the complexities and legal/financial considerations for practicing abroad as well as the differences between foreign and domestic markets. Presents a general overview of international practice. \$12/\$15.

Architect's Handbook of Professional Practice (1M104)

Three-volume set in ring binders includes samples of all A, B, C, D, E and G documents, plus 20 chapters and a glossary of construction industry terms. \$30/\$45.

Architects in Government Roster (2M161)

Names and addresses of 2,300 architects employed by federal, state and local governments (1980). \$5/\$6.

***Architectural Delineation: A Photographic Approach to Presentation (3M128)**

How the camera can be utilized in architectural and design presentation is the subject of this extensively illustrated 298-page book (1971) by Ernest Burden. It describes the various ways of preparing a layout for use with a camera, plus the techniques of drawing for final presentations. \$33/\$36.50.

Architectural Graphic Standards, Seventh Edition (3M475)

800-page book (1981) prepared by the AIA. A source book and standards guide for sizes, dimensions and details for all building materials and equipment. \$67.50/\$75.

Books, Etc., to Order Through the Institute

***Architectural Illustration: The Value Delineation Process (3M404)**

256-page book (1979) by Paul Stevenson Oles, AIA, describes the best communication modes to use, presented from the architect's point of view. Models, computer graphics, design drawing representations and their advantages and disadvantages are covered in depth. The system presented here is useful for architects in terms of flexibility, applicability and quality of finished product. \$31.25/\$34.50.

***Architectural Registration Handbook (3M155)**

Annual guide (1981) prepared by the National Council of Architectural Registration Boards for those taking Section B of the professional examination for architectural registration. Section A is covered by NCARB Design Test Handbook (3M427), listed separately. \$22.50/\$25, tentative price.

Architectural Secretaries Handbook (4M131)

Loose-leaf volume contains information on the Architectural Secretaries Association, the secretary and the office, the secretary and the project, reference materials and glossaries. Temporarily out-of-print.

Architectural Secretaries Handbook Supplement, 1978 (4M131-1)

Updated information for 1975 edition only of ASA Handbook. \$3.50.

***Architectural Signing and Graphics (3M387)**

Written by John Follis and Dave Hamner, this 232-page book (1979) provides detailed practical information on the signing and graphics requirements of a variety of projects and outlines business procedures and practices involved in the design solution. \$29.25/\$32.50.

***Architecture and Energy (3M279P)**

322-page (1977) study by Richard G. Stein, FAIA, of the needless waste of resources in today's buildings and homes. The author outlines steps required to revolutionize the design process and provide more efficient and livable structures. Paperback, \$6.25/\$6.95.

***Architecture in Context: Fitting New Buildings with Old (3M485)**

160-page book (1980) by Brent C. Brolin serves as a guide to the design, planning and zoning of new buildings. \$15.25/\$16.95.

***Architecture of the Western World (3M472)**

Edited by Michael Raeburn, this 304-page book (1980) is a comprehensive overview of the history of architecture from the Greeks and Romans down through the revolutionary modernists of

this century. \$33.75/\$37.50.

***Architecture Schools in North America (3M124)**

Edited by Roger Schluntz, AIA, and Sarah V. Weaver, this 271-page book (1978) contains the official architectural program descriptions of the 99 member schools and the 20 affiliate schools of the Association of Collegiate Schools of Architecture, located throughout the U.S. and Canada. \$8.25/\$8.95.

B

Basics of Solar Heating and Hot Water Systems (2M262)

48-page publication (1977) from AIA Research Corporation discusses passive and active systems. Introduces systems design considerations, from collector components and placement, to storage and heat exchangers, to distribution. \$4.75/\$6.

***Behavioral Architecture: Toward an Accountable Design Process (3M272)**

203-page book (1977) by Clovis Heimath, FAIA, is a study and documentation of the often adverse psychological effects of buildings on people. Taken from an architect's viewpoint, it offers practical guidelines and step-by-step procedures to make certain the human element is included when designing viable buildings. \$19.50/\$21.50.

***Bucket of Oil (3M174)**

Written by William W. Caudill, FAIA, et al., this 87-page book (1974) gives examples of building designs that conserve energy and meet human and esthetic needs at the same time. \$10/\$10.95.

***Building Contracts for Design and Construction (3M224)**

352-page book (1976, second edition) by Harold D. Hauf, FAIA, focusing on recent problems in professional liability. It identifies the principal contingencies that may arise, discusses the details of contract forms and suggests methods for handling disputes that will be equitable to all parties involved. \$29/\$32.

Building Underground for People: Eleven Selected Projects in the United States (4M711)

30-page report (1978) by Michael Barker, AICP, presents a sampling of underground projects in the U.S. Information includes description of each project, owner, design team, contractor, size, cost, date of completion and decision to build subsurface. \$6/\$7.

***Building Without Barriers for the Disabled (3M232)**

80-page guide (1976) by Sarah Harkness, FAIA, and James Groom, AIA, to

designing public buildings that are safe, convenient and easily accessible to the physically handicapped. Photographs illustrate design solutions for the special needs of disabled and elderly. Drawings and diagrams, in both inches and meters. \$10/\$10.95.

***Buildings Reborn: New Uses, Old Places (3M411)**

Barbaralee Diamonstein, in her 255-page book (1978), provides a 20-page explanatory introduction on preservation in general and adaptive use in particular. The 95 cases that follow give a brief but well-rounded look at adaptive use. Entries include the better known projects (Ghirardelli Square, etc.) as well as many little-known but equally useful cases. Paperback, \$9/\$10.

***Built to Last: A Handbook on Recycling Old Buildings (3M410)**

Written by Gene Bunnell, this 126-page book (1978) contains 33 major and several dozen shorter case studies of adaptive use projects with costs and construction details, organized by building type. Paperback, \$6.25/\$6.95.

***Businessman's Guide to Construction (3M451)**

450-page reference (1980) by Robert F. Cushman and William J. Palmer gives specific recommendations to the businessman and the advising professional seeking to proceed through the construction process with understanding and confidence. The 13 chapters are organized to follow the construction process from the owner's viewpoint, though each chapter may be read independently. Presents effective guidance recommended by experts. \$31.50/\$35.

C

***Castle (3M284)**

80-page book (1977) by David Macaulay, based in concept, structural process and physical appearance on several castles built to aid in the conquest of Wales between 1277 and 1305 A.D. For ages 10 and up. \$10/\$10.95.

***Cathedral (3M192)**

80-page book (1973) by David Macaulay, graphically explaining the creation of the cathedral, from the building of the foundation to the completion of the towers. Ages 10 up. \$10/\$10.95.

***Central City Malls (3M415)**

200-page book (1978) by Harvey M. Rubenstein illustrates how pedestrian malls have become part of the revitalization of downtown business districts. Analyzes factors that determine a mall's feasibility, size, location and cost. Contains 22 case studies and a catalog of data on 90 malls. \$24.75/\$27.50.

***Children's Spaces: 50 Architects and Designers Create Environment for the Young (3M377)**

In this 222-page book (1978), Molly and Norman McGrath have gathered examples of children's spaces under one cover. The main body of the text is given over to the designers' own discussions of their attitudes toward designing spaces for children—showing how space can be planned from the beginning to change as the child grows. \$27/\$30.

***City (3M193)**

112-page book (1974) by David Macaulay, showing the development of a Roman city, from the planning stage through construction. Ages 10 up. \$9/\$9.95.

***Compensation Guidelines for Architectural and Engineering Services, Second Edition (2M188)**

Prepared by AIA with the assistance of the American Consulting Engineers Council, this 160-page (1978) financial management tool places equal emphasis on both the architectural and engineering services required for building projects. Provides a rational process for relating design professionals' compensation to cost of services. Shows how to work with the client to analyze a project, item by item, to reach an agreement on scope of services required. \$12/\$15.

***Computer Aided Architectural Design (3M375P)**

573-page book (1977) by William J. Mitchell provides a comprehensive introduction to the subject of computer-aided architectural design. No detailed knowledge of programming is assumed, although some familiarity with a programming language will be helpful, as well as a knowledge of elementary algebra and trigonometry. The text is supplemented by several hundred original diagrams. \$15.25/\$16.95.

***Concepts in Building Firesafety (3M358)**

M. David Egan, in this 264-page book (1978), presents the principles of design for firesafety in an easy-to-follow graphic format. More than 270 illustrations help design professionals conceptualize problems and solutions of fire ignition and spread in buildings, site planning, build-

ing materials and construction, fire detection and suppression systems for buildings, smoke and heat venting techniques, escape and refuge principles. \$28/\$31.

***Concepts in Thermal Comfort (3M186)**

224-page book (1975) by M. David Egan is a resource book on energy conservation design and construction principles. Text stresses the importance of integrating mechanical systems with building structures, minimizing building heat loss or heat gain and conserving valuable resources and energy. Illustrated with graphs, charts and tables of technical and engineering data to aid in solving actual building problems. Appendices provide formulae and additional references. \$14.50/\$15.95.

***Construction Bonds and Insurance Guide, Second Edition (2M163)**

Loose-leaf reference book (1979) prepared by Bernard B. Rothschild, FAIA, containing up-dated information on bonds and insurance related to construction projects, with glossary of insurance terms and suggested check list. \$16/\$20.

***Construction Business Handbook: A Practical Guide to Accounting, Credit, Finance, Insurance, and Law for the Construction Industry (3M368)**

Edited by Robert Cushman, this 760-page handbook (1978) is an efficient source of time-tested techniques for solutions to specific problems that arise time and again in the construction industry. Answers to questions involving accounting, insurance, contracts, bonds, bids and more may be found in 53 chapters. \$35.75/\$39.50.

***Creative Communications for a Successful Design Practice (3M300)**

192-page book (1977) by Stephen A. Kliment, FAIA, is a tool for design professionals who want to develop skills and techniques needed to communicate effectively with present and potential clients, the media and the public. \$20.25/\$22.50.

***Current Techniques in Architectural Practice (2M701)**

275-page book (1976) edited by Robert Allan Class, AIA, and Robert E. Koehler, Hon. AIA. An overview of architectural practice, with emphasis on management, plus a comprehensive, annotated bibliography. \$22/\$27.50.

continued on page 126

WHEN SKYLIGHTS OF EXOLITE™ SHEET JOINED THE PAERDEGAT RACQUET CLUB, ENERGY COSTS DROPPED 40%. NET.

And tennis buffs could keep their eye on the ball better than ever.

From the moment the Paerdegat Boat and Racquet Club opened in Brooklyn, New York in 1974, tennis activity at the huge prefab steel building soared. So did the club's electric utility bills.

To fight the rising costs, and still not raise court fees,

the club decided to raise the roof instead.

Sixty-four skylight panels made from EXOLITE double skinned acrylic sheet were installed in October 1978. The result has been a whopping 40% reduction in electric bills. With natural light to brighten the courts during daylight hours, artificial lighting is rarely used during

the day in the 60,000 sq. ft. building.

EXOLITE sheet's high light transmission prime factor for choice of skylights.

The light transmittance of clear EXOLITE acrylic sheet is nearly equal to that of double glazed glass. But EXOLITE sheet has several times the impact strength of glass of equal skin thickness. So it's ideal for applications such as skylights where you need transparency and toughness.

All this and high insulation value, too.

The ribbed configuration of EXOLITE double skinned sheet traps air to provide an insulating value comparable to 5/8 in. thick insulating glass.

The 4 ft. x 14 ft. EXOLITE panels are load-bearing but non-structural. Combining physical properties of structural rigidity and light weight, the panels were easily fabricated and installed.

And on-site installation did not interfere with the "point, set and match" activity down on the courts below.

A lot of bright ideas come from EXOLITE sheet.

Designers and architects find that the sky's the limit when they use EXOLITE sheet for skylights. But it's also ideal as a glazing material for solariums, swimming pool enclosures, greenhouses, curtainwalls and for passive solar energy installations for homes, schools, and commercial and industrial applications.

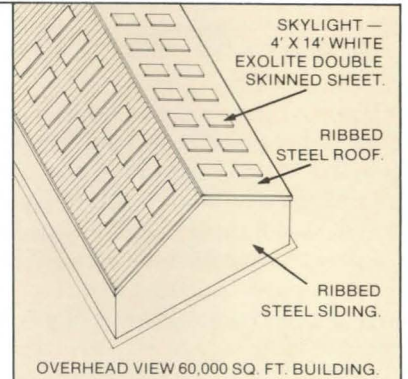

If you need to save energy and still want to see the light, take a good look at EXOLITE double skinned acrylic sheet or vandal-resistant polycarbonate sheet.

With high rigidity, light weight, impact resistance, easy workability, and design freedom all going for you, it makes a lot of sense to investigate our product.

If you want to know more about how EXOLITE sheet can put a lid on energy costs, please contact us at 697 Rt. 46, Clifton, NJ 07015, (201) 560-0485. In Canada: Chemacryl Plastics Limited, 73 Richmond St. W., Toronto, Ont. M5H 2A2.

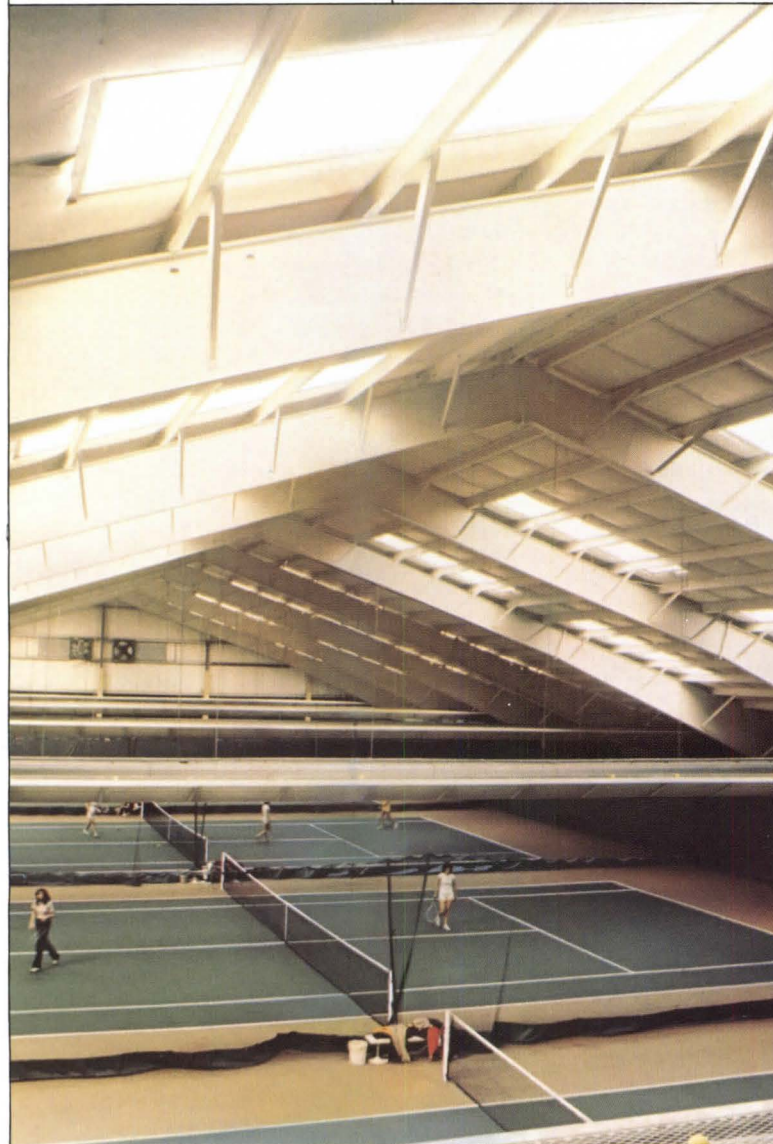

CYRO Industries

A Partnership of Cyanamid Plastics, Inc. and Rohacryl, Inc.

Circle 41 on information card

Caution: EXOLITE double skinned sheets are combustible thermoplastics. Precautions used to protect other common combustibles should be observed. Building Codes should be followed carefully. Further data are available from CYRO Industries.

D

Directory of Justice Facilities (2M722)

Prepared by the AIA committee on architecture for justice, this 59-page book (1979) is a directory of the participants in a 1979 exhibit of justice facility projects, cosponsored by AIA and the American Correctional Association. \$4/\$5.

***Design Competitions (3M423)**

288-page book (1979), by Paul Spreiregan, FAIA, provides an historical survey of design competitions for architectural, landscape, industrial and city planning projects. It explains the actual mechanics of arranging, operating and entering a design competition and gives hints on the actual and proposed role of competitions. Illustrated. \$22.50/\$24.95.

***Design Cost Analysis for Architects and Engineers (3M454)**

Stressing the importance of a team effort among architect, structural, mechanical and electrical engineers, and cost managers, on every design effort, the 224-page book (1980) by Herbert Swinburne, FAIA, provides a workable method tied to a readily available cost data base for determining costs of 15 different building systems. Profuse examples and a hypothetical case study illustrate how to implement the procedures and avoid errors and liabilities. \$19.50/\$21.50.

***Design for Accessibility (3M416)**

Practical, 256-page on-the-job book (1979) by Robert James Sorensen explains graphically every currently developed standard and recommendation for handicapped access design. Drawings, dimensioned in both USCS and SI units, cover details involved in site development and parking, building access and circulation (halls, stairs, ramps, elevators), building areas, details and accessories. Latest codes, standards and regulations are detailed. \$23.50/\$25.95.

***Design Plus Energy (4M478)**

80-page publication (1980) is the result of an ACSA national student design competition concentrating on various passive solar energy systems and thermal massing techniques, with emphasis on brick masonry construction. \$5.

***Design Primer for Hot Climates (3M486)**

Allan Koyna's 128-page book (1980) offers a highly practical introduction to

solving design problems in arid, semiarid, subtropical and tropical climates. \$15.75/\$17.50.

Design Resources File: Planning Justice Facilities (2M714)

Updated by the AIA committee on architecture for justice, this 95-page resource (1980) contains: a summary of the 1972 task force report on the state of the art in architecture for justice and some recommendations for action; guidelines for the justice planning process; resource and bibliographies pertaining to court, correctional and juvenile justice facilities, and an evaluation checklist for law enforcement facilities. \$10/\$12.50.

Design Review Boards: A Handbook for Communities (2M203)

52-page résumé (1974) of the law on design review and an annotated model ordinance to guide communities that choose to adopt a design review board process. \$5.75/\$7.

***Designing and Building a Solar House: Your Place in the Sun (3M25P)**

288-page book (1977) by Donald Watson, AIA, demonstrates the most sensible ways to combine good residential design with contemporary solar heating technology within building costs of conventional homes. Delves into topics such as active and passive solar heat systems, hot water systems, calculating wind, temperature range and sun exposure factors on the sites. Includes complete checklist of equipment needs and a comprehensive source list of products and material. More than 400 illustrations. Paperback, \$10/\$10.95.

***Designing for Human Behavior: Architecture and the Behavioral Sciences (3M240)**

Edited by Jon Lang, and others, this 368-page book (1974) is concerned with raising the standard of the designed environment to meet human needs on as many levels as possible. Designers interested in the human element of their work will benefit from this book. Paperback, \$16.75/\$18.50.

***Designing the Open Nursing Home (3M289)**

175-page book (1976) edited by Joseph A. Koncelik offers much needed research on the social, behavioral and physiological characteristics of the elderly infirm. Provides a clear guide to developing microenvironments that are residential in nature rather than sterile and institutional. \$23.50/\$26.

A Directory of Minority Architectural/Engineering Firms (2M709)

The directory (1978) prepared by AIA and the American Consulting Engineers

Council (ACEC) lists both member and nonmember minority architectural and engineering firms nationwide. \$5/\$10; \$5 for ACEC members.

E

***Earth Shelter Handbook (3M456)**

Written by Tri/Arch Associates, this 244-page handbook (1980) is neither totally technical nor theoretically abstract but a mixture of both. Principles of site selection and preservation are presented, as well as graphic and verbal descriptions of various structural and building subsystems, construction details and techniques. Illustrated. \$11.75/\$12.95.

***Earth Sheltered Homes (3M501)**

The Underground Space Center, University of Minnesota, has prepared this 160-page book (1981) featuring dozens of innovative home designs that are at least partially protected and insulated by the earth's surface. \$15.25/\$16.95. Paperback (3M501P), \$9/\$9.95.

***Earth Sheltered Housing Design: Guidelines, Examples, and References (3M381)**

310-page book, produced by the Underground Space Center at the University of Minnesota, is the first comprehensive manual on underground housing design. It introduces the basic considerations of earth sheltered design and presents detailed layouts and photographs (300) of existing houses, built in both warm and cold climates. Offers precise information on financing, building codes, product information and a bibliography. \$16.25/\$17.95. Paperback (3M381P), \$10/\$10.95.

***Encyclopedia of American Architecture (3M466)**

640-page reference (1980), by William Dudley Hunt Jr., FAIA, contains data on building types, components and materials; renowned American architects and their methods; energy alternatives, etc. \$36/\$39.95.

***Energy Conservation Design Resource Handbook (4M428)**

450-page handbook (1979) summarizes systematically all design principles and related architectural, engineering, planning and economic considerations applicable in architectural design. Prepared by the energy task force of the Royal Architectural Institute of Canada, the information on energy conserving measures is con-

continued on page 128

Echoes of the past, promises for the future.

Answers for "Renaissance America"



It is the blending of a major historical theater/landmark with an all-purpose cultural center. It is the Five Flags Civic Center, pride of Dubuque, Iowa. The irreplaceable theatrical treasure, earliest known example from America's premier theater architectural firm, Rapp & Rapp, forms a harmonious union with a new 27,000 square foot civic arena.

The painstaking renovation and imaginative new facility are part of "Renaissance America." And Gold Bond Building Products is there with answers—three types of plaster, including that used in the restoration of decorative plaster moldings, gypsum wallboard, steel studs, joint compound and Spray Quick textured ceiling finish.

Gold Bond provides answers for your part in "Renaissance America"—in products, systems and services. For more information, call 800-821-7700, Ext. 327 (in Missouri, 800-892-7655) or write Gold Bond Building Products, Dept. AIA, Charlotte, N.C. 28211.

**Gold Bond
Building
Products**

A National Gypsum Division

Books from page 126

cisely written using a blend of tests, diagrams, charts, illustrations and calculations in metric measurements. Loose-leaf binder. \$75.

Energy Conservation in Building Design (3M212)

Prepared by the AIA Research Corporation, this 156-page book describes opportunities for conserving energy through building design. It is the product of a national energy policy study financed by the Ford Foundation to investigate various aspects of the technological and social impacts of energy supply and consumption. \$4.50/\$5.

***Energy Conservation in Buildings (3M184)**

183-page book (1975) by Charles W. Griffin contains a subject-by-subject examination of the building items that offer opportunities for reduction in energy use. \$18/\$20.

***Energy Conservation in Buildings and Industrial Plants (3M490)**

Written by Milton Meckler, this 320-page book (1980) coordinates building design, construction and operation, and determines their impact on energy conservation strategies. \$20.25/\$22.50.

***Energy Conservation Standards (3M371)**

Written by Fred S. Dubin and C. G. Long Jr., AIA, this 413-page comprehensive guide (1978) gives the practical methods for managing energy in any structure designed, built, maintained or operated. Contains checklists and charts needed to trace and measure the energy flow in every given building, from heat loss in walls and roofs to the economics of HVAC and electrical systems. \$25.25/\$27.95.

***Energy Conservation Through Building Design (3M389)**

224-page book (1979), edited by Donald Watson, AIA, comes in response to today's growing concern with the conservation of energy. Articles and references outline the basic concepts and directions necessary for energy efficient building design; a reliable source for guidelines. \$20/\$21.95.

***Energy-Efficient Buildings (3M463)**

From the pages of *Architectural Record*, Walter Wagner, AIA, has edited a readable 192-page overview (1980) of the history of energy conservation in building design since the early 1970s. Included is a discussion of solar energy and underground buildings. \$26.75/\$29.50.

***Energy Handbook (3M396)**

640-page book (1978) by Robert L. Loftness is a major compilation and survey of energy resources, costs, conservation, efficiency, depletion, storage, transport, consumption, conversion technologies and environmental factors. It covers such areas as nuclear, oil, geothermal, coal, wind, solar and tidal energy sources. \$44.75/\$49.50.

***Energy in the Design Process (4M477)**

A 56-page reference workbook (1980) prepared for a joint Royal Architectural Institute of Canada/AIA conference/workshop on the integration of energy-consciousness into architectural design, held in October 1980 in Toronto. Loose-leaf binder. \$30.

Energy Planning for Buildings (4M720)

Written by Michael Sizemore, AIA, et al., this 156-page book (1979) presents a proven process that design professionals can use (or adapt) to study the current energy performance of a building, uncover opportunities for energy-conscious improvements, evaluate those opportunities and see that they are carried out to the building owner's best benefit. Describes in detail a manual technique for calculating energy usage and shows in a



Noise... Control it.

**Eckoustic Functional Panels
efficiently & effectively reduce
background noise & reverberation.**

Ideal for auditoriums, gyms, swimming pools, churches, etc. Easy installation. No need to relocate existing utilities. Attractive. Durable. Fireproof. Low maintenance. Graffiti resistant.



ECKEL INDUSTRIES, INC. Eckoustic Div.
155 Fawcett St., Cambridge, Mass. 02138 • 617-491-3221

Prevent water damage in high rise apartments

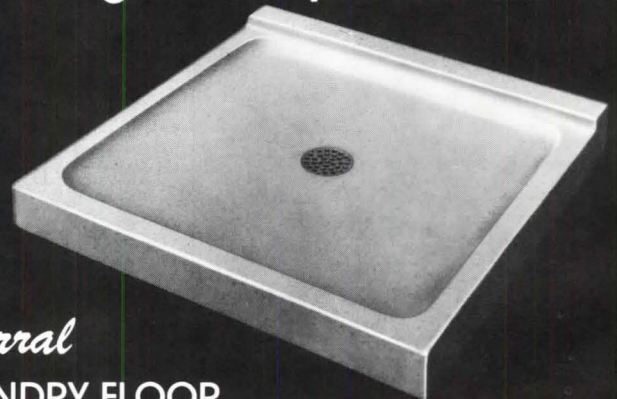

Corral
LAUNDRY FLOOR

Build in protection against washing machine overflow. Avoid damage to utility room floors and ceiling below. And prevent "creeping" of machines under heavy load and high spin. Fresh attractive Terrazzo is stain resistant and easy to maintain. Installs direct on the finished floor, saves 30% to 50% compared to on-site construction. Ideal for condominiums, rental units, and housing for elderly.

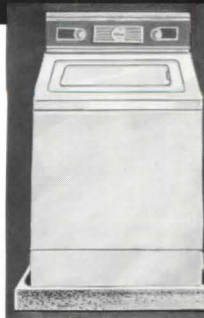

Model No. LF-10

WILLIAMS

STERN-WILLIAMS CO., INC. • P.O. Box 8004, Shawnee Mission, Kansas 66208

Circle 44 on information card

sample problem how that technique can be applied. Also provides a basis for understanding computer-aided energy estimating techniques. \$40/\$44.

F

Financial Management for Architects (2M724)

The "umbrella" book of the AIA financial management systems, the 200-page manual (1980), by Robert Mattox, AIA, covers basic theories and applications appropriate to all size design firms. It examines financial goals, profit planning and the interrelationships of accounting reports, financial controls and the broad view of managing firm finances. Illustrated. \$22/\$27.50.

***The Form of Housing** (3M359P)

Sam Davis, AIA, edited this well-illustrated 299-page book (1978) that describes the main forms of urban housing during the past three decades. It examines changing attitudes of builders and developers, the movement toward conservation of old housing, plus numerous projects. There are also extensive bibliographies. Paperback, \$13.50/\$15.

Funding Sources for Architectural Programs: Foundations Supporting the Built Environment (4M719)

A 150-page funding source listing (1978) compiled by the AIA Foundation and the National Endowment for the Arts. Contains essential information on more than 200 foundations that support the built environment. \$5.

G

Glossary of Construction Industry Terms (2M101)

18-page publication (1970), including definitions of terms with special meaning or connotation in the construction industry. \$1.25/\$1.50.

***A Golden Thread: 2,500 Years of Solar Architecture and Technology** (3M498P)

Ken Butti and John Perlin have written a carefully researched, 304-page history (1980) of solar energy, illustrating successful solar energy applications of the past. \$9/\$9.95.

***A Guide to Architecture in Los Angeles and Southern California** (3M393)

600-page guidebook (1977), by David Gebhard and Robert Winter, contains

3,000 entries for the geographic area extending from San Simeon on the north to the Mexican border on the south and the island deserts on the east, including the San Joaquin Valley. The tourist is provided with 1,000 illustrations, including maps and descriptions, plus a glossary and bibliography. Paperback, \$10.75/\$11.95.

***A Guide to Architecture in San Francisco and Northern California** (3M392)

Published for the 1973 national AIA convention, the 560-page guide by David Gebhard, et al., contains maps for touring, along with succinct descriptions of the various areas visited and buildings viewed. Includes a glossary and bibliography along with 600 illustrations. Paperback, \$9/\$9.95.

***A Guide to New Orleans Architecture** (3M382)

Prepared by the New Orleans Chapter/AIA, this 177-page guidebook provides suggestions, with maps, for 18 tours. Beginning with the French Quarter (Vieux Carre), it leads the tourist through neighborhoods of small, narrow Victorian "shotguns" or "camelbacks" (a pictorial glossary is provided) to the large-scale

Don't trust your packages to a fly-by-night delivery service.

Especially when you need your packages delivered today. Trust American Airlines. Our Priority Parcel Service delivers small parcels virtually anywhere *in hours*, 24 hours a day. Seven days a week.

We have over 900 daily departures, 'round the clock, throughout the continental U.S., Hawaii, Canada, Mexico and the Caribbean. And when you call toll-free (800) 638-7320, we'll even provide door-to-door service any time of the day or night.

So call American for delivery today. You can trust us.

American Airlines
Priority Parcel Service
Doing what we do best.

Circle 45 on information card



AN OPEN CALL FOR ENTRIES IN THE CRSI DESIGN AWARDS.

Contemporary or classical can win.

You could be the proud recipient of one of the coveted awards to be presented in the Sixth CRSI Design Awards Program.

If you're a registered architect or engineer, you owe it to yourself to enter CRSI Design Awards VI.

These Awards honor creative design achievement in reinforced concrete construction and they bestow national recognition on their recipients. Winners will be honored at

CRSI National Convention at the Greenbriar, White Sulphur Springs, W. Virginia.

Your structure must be of cast-in-place reinforced concrete, using conventional reinforcing bars as the principal reinforcement. Structure must have been completed since January 1, 1979 or essentially completed by November 1, 1981. Program is A.I.A.-endorsed and rules are equally simple.

Please send me the Guide for Entries in CRSI Design Awards VI.

NAME _____ TITLE _____
FIRM _____
ADDRESS _____
CITY _____ STATE _____ ZIP _____
PHONE () _____



Mail to: **CONCRETE REINFORCING STEEL INSTITUTE**
180 North LaSalle Street, Room 2111D, Chicago, Illinois 60601
Attention: Vice President/Marketing & Promotion
Phone: 312/372-5059



Circle 46 on information card

AIA JOURNAL/MID-AUGUST 1981 129

houses of the Garden District, to the newer suburbs, following a full range of architectural styles. Paperback, \$3.

***A Guide to Business Principles and Practices for Interior Designers** (3M464) Harry Siegel, CPA, provides a well-organized 202-page book (1968) setting forth the basic principles, procedures and office systems to solve financial and operational problems and establish a sound business-like practice. \$17.75/\$19.50.

H

***Handbook of Building Security Planning and Design** (3M400)

Edited by Peter S. Hopf, AIA, this 576-page handbook (1979) provides comprehensive design information on all aspects of physical security for every type of building. Deals with the unique safety requirements for differing buildings—libraries, schools, highrise office buildings, health care facilities and many others—each with its own particular needs. Diagrams, charts, checklists and a security product directory are included. \$38.25/\$42.50.

***Handbook of Energy Audits** (3M492) Albert Thumann has written a 443-page handbook (1979) that explains the techniques involved in surveying a building, determining energy utilization and conducting an audit to fit a particular building or facility. Includes accounting forms and checklists. \$29/\$32.

***Hospital and Health Care Facilities** (3M345)

This 193-page volume (1978), edited by Louis Redstone, FAIA, helps solve overall planning and construction problems; covers the gamut from small clinics to large public hospitals. \$33/\$36.50.

***Hospital Planning Handbook** (3M134) 242-page book (1976) by Rex Whitaker Allen, FAIA, and Ilona von Karolyi outlines the processes involved in planning health care facilities and hospitals. \$24.75/\$27.50.

***Hotels, Motels, and Condominiums: Planning and Design** (3M243) 250-page book (1976) by Fred Lawson is a reference source on marketing and research, architectural design, engineering data and operations analysis of hotels and other tourist facilities. Covers everything from cocktail lounges to sleeping rooms to back-of-the-house mechanical equipment. Discusses current international trends and up-to-date standards affected by such things as energy shortages, new concepts of safety, comfort and noise reduction. 150 illustrations. \$45/\$49.95.

***Housing for the Elderly: The Development and Design Process** (3M142)

A 174-page (1975) ready-to-use guide, by Isaac Green, AIA, and others, for producing high quality housing for older Americans. Pinpoints housing that meets physical, social, perceptual needs of senior citizens. Emphasizes types of shelter, environments and services required by both the independent elderly and those who need limited health and social services. \$17.25/\$18.95.

***How to Prepare Professional Design Brochures** (3M223)

277-page book (1976) by Gerre Jones, Hon. AIA, to guide those planning a promotional brochure showcasing their professional services. Discusses the procedure from start to finish, including the areas of scheduling, budget, layout, copywriting, type, paper and printing. Shows numerous examples, and also covers supplemental publications such as newsletters. \$24.75/\$27.50.

***How to Recycle Buildings** (3M425) 245-page book (1979), by Laurence E. Reiner, shows how to successfully rehabilitate or recycle structurally sound buildings for profit. The author presents the practical "how-to's" on finding, evaluating, surveying, financing and marketing recycling projects profitably. Case studies, illustrations, graphs, charts and tables are included. \$19.75/\$21.95.

I

***Institutional Buildings: Architecture of the Controlled Environment** (3M469)

Edited by Louis G. Redstone, FAIA, this 182-page book (1980) is a compendium of the architecture of correctional institutions, courthouses, mental health facilities, buildings for the elderly and child care centers, taken from the pages of *Architectural Record*. \$24/\$26.50.

***Interior Design: An Introduction to Architectural Interiors, Revised Edition** (3M484)

Written by Arnold Friedmann et al., 432-page book (1976) is concerned with the basic facets of the design of interiors as well as its relationship to the environment in general. Updated to include environmental behavior, supergraphics and office landscaping. \$23.50/\$25.95.

***Interiors 2nd Book of Hotels** (3M395)

In this profusely illustrated, 224-page book (1978), Henry End discusses the changes in the hotel industry in the past 15 years. Subjects covered include: the design team, the consultants, types of hotels, hotel spaces and their function and much more. \$24/\$26.50.

International Directory of the American Institute of Architects (4M481)

157-page reference (1981) prepared for AIA by Archimedia provides a broad selection of American architectural firms with a description of the international services they offer. \$10/\$12.95.

Into the Mainstream: A Syllabus for a Barrier-Free Environment (3M132)

44-page report (1975) by Stephen Kliment, FAIA, containing practical information on how a community can achieve a barrier-free environment. \$2.75/\$3.

L

***Legal Aspects of Architecture and Engineering, Second Edition** (3M319)

In this 987-page volume (1977), Justin Sweet discusses the antitrust attacks on traditional professional practices relating to fees and clients. Also covers construction organization techniques such as construction management, fast track systems and design/build. \$19/\$20.95.

Life Cycle Cost Analysis: A Guide for Architects (2M708)

Provides architects, engineers and clients with a straightforward and usable technique allowing them to consider all relevant economic consequences of design decisions. A 45-page primer (1978) prepared by the life cycle cost analysis task force of AIA. Paperback, \$10/\$12.50.

Life Cycle Cost Analysis 2: Using It in Practice (2M713)

This 88-page book (1978) responds to the question: Where in the planning and design process can the life cycle cost analysis technique be effectively used? Provides guidelines for selecting application areas and a number of case study applications, as well as commentary on the planning and design process. The publication presents an introduction to the life cycle cost analysis technique and a picture of its current use in practice. Paperback, \$14.50/\$18.

M

***Managing an Architectural and Engineering Practice** (3M497)

Weld Cox has written a comprehensive 177-page guide (1980) to the basics of management as it uniquely applies to the professional architectural and engineering practice and its commitment to a qualitative bottom line. \$18/\$19.95.

Managing Architectural Projects: The Effective Project Manager (2M730)

The second volume of the project manager series by David Haviland, this 48-

page book (1981) deals with the psychological aspects of improving the performance of the project manager. \$8/\$10.

Managing Architectural Projects: The Process (2M727)

Written by David Haviland, this 112-page book (1981) outlines essential project management activities and shows how offices can organize to carry them out. The first of a series of three on project management. \$16/\$20.

Manual of Steel Construction, Eighth Edition (3M117)

Here is an essential reference for architects, engineers and many others concerned with the construction industry.

More than 1,100 pages, this latest edition (1980) is based on the provisions of the AISC "Specification for the Design, Fabrication and Erection of Structural Steel for Buildings." Data are divided into six basic sections. \$32.50/\$36.

Minimum Energy Dwelling (MED) Workbook: An Investigation of Techniques and Materials for Energy Conscious Design (4M366)

Written for the Department of Energy by Burt, Hill & Associates, this 430-page workbook (1978) presents issues dealing with energy conservation in dwellings:

general considerations, building design, mechanical design. Includes a glossary. Paperback, \$9/\$10.

N

***Natural Solar Architecture (3M322)**

254-page handbook (1978) by David Wright, AIA, for those wanting to find out more about passive solar architecture. Paperback, \$8.25/\$8.95.

***Natural Ventilation, Passive Cooling and Human Comfort in Buildings: A Comprehensive Technical Bibliography (4M502)**

Prepared for Thomas Vonier Associates, Inc., this 36-page bibliography (1980) is the first in a planned series of technical publications on the uses of wind for buildings. \$9/\$10.

***NCARB Design Test Handbook (3M427)**

94-page study guide (1980) for Section A of the NCARB professional examination contains actual design solutions by candidates to the 1979 problem, together with expert critiques by NCARB's examinations coordinating council. Will be updated annually. \$28/\$31.

New Design Concepts for Energy Conserving Buildings (2M263)

124-page book (1977) describes 115 innovative approaches to designing energy-efficient buildings. Contains bibliography and design concept index keyed to drawings. \$9/\$9.95.

1980 Architecture for Justice Exhibition Directory (2M728)

39-page directory of the 1980 exhibit of justice facility projects, sponsored by the AIA and the ACA, illustrating the current design efforts in this specialized field. \$8/\$10.

O

***Old and New Architecture: Design Relationship (3M496)**

Prepared by the National Trust for Historic Preservation, this 280-page book (1980) explores the controversial question of how new architecture should relate to its historic surroundings. From a conference sponsored by the trust, the Latrobe Chapter of the Society of Architectural Historians and the Washington Metropolitan Chapter/AIA. \$22.50/\$25. Paperback (3M496P), \$14.50/\$15.95.

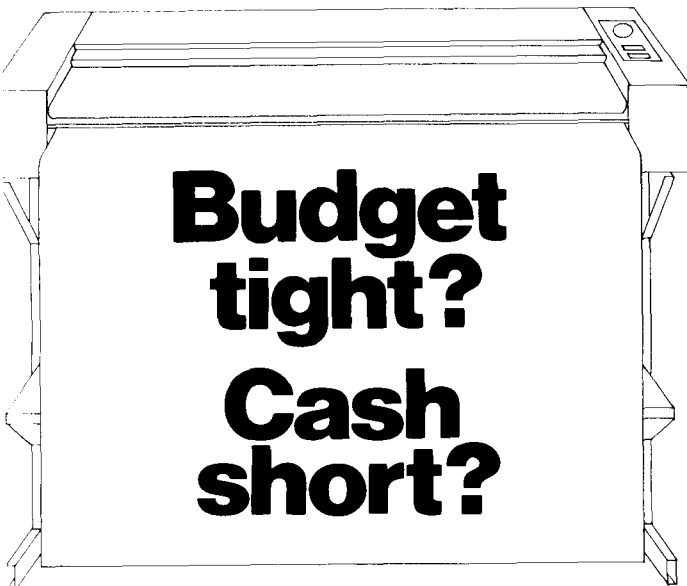

Our attractive lease/rental program lets you get all the advantages of a top quality GAF® Fluorescent Diazoprinter with minimal cash outlay. For details, call toll-free 1-800-223-0344 (within New York State, call 1-800-522-5250), or write GAF Corporation, Reprographic Products, 140 W. 51 Street, New York, NY 10020.

GAF Fluorescent Diazoprinters
© 1981 GAF Corporation

Circle 47 on information card

AN OPEN CALL FOR ENTRIES IN THE CRSI DESIGN AWARDS.

Functional or fanciful can win.

You could be the proud recipient of one of the coveted awards to be presented in the Sixth CRSI Design Awards Program.

If you're a registered architect or engineer, you owe it to yourself to enter CRSI Design Awards VI.

These Awards honor creative design achievement in reinforced concrete construction and they bestow national recognition on their recipients. Winners will be honored at

CRSI National Convention at the Greenbriar, White Sulphur Springs, W. Virginia.

Your structure must be of cast-in-place reinforced concrete, using conventional reinforcing bars as the principal reinforcement. Structure must have been completed since January 1, 1979 or essentially completed by November 1, 1981. Program is A.I.A.-endorsed and rules are equally simple.

Please send me the Guide for Entries in CRSI Design Awards VI.

NAME _____ TITLE _____
FIRM _____
ADDRESS _____
CITY _____ STATE _____ ZIP _____
PHONE () _____



Mail to: **CONCRETE REINFORCING STEEL INSTITUTE**
180 North LaSalle Street, Room 2111D, Chicago, Illinois 60601
Attention: Vice President/Marketing & Promotion
Phone: 312/372-5059



Circle 46 on information card

AIA JOURNAL/MID-AUGUST 1981 131

***Open Office Planning: A Handbook for Interior Designers and Architects** (3M388)

By John Pile, this 208-page handbook (1978) presents a systematic approach that requires use of specific methodology in organizing the physical layout of an open office with the primary purpose of facilitating communication among the staff. \$15.25/\$16.95.

***Opportunities in Architecture Today** (3M112P)

117-page book (1981) by Robert J. Piper, FAIA, analyzing all occupational facets of the architectural profession. Paperback, \$5.25/\$5.95.

P

***Passive Solar Energy Book: Expanded Professional Edition** (3M399)

This comprehensive, 548-page book (1979) by Edward Mazria contains information that will be invaluable to the serious solar designer. Included are: 27 rules of thumb for choosing a solar system; 13 exclusive appendices containing a precise set of tools for predicting a building's performance; five transparent sun charts locating the sun's position at any time, during any month, for most U.S. and Canadian locations; computerized analysis of solar heat, specific gravity and thermal conductivity of 160 solids and liquids. Illustrated. \$22.50/\$24.95.

***Perception and Lighting as Formgivers for Architecture** (3M316)

In this 310-page book (1977), William M. C. Lam discusses the working tools of the lighting designer; points out pitfalls and how to avoid them. 55 case study projects are discussed. \$40.25/\$44.50.

Personnel Practices Handbook, Second Edition (2M138)

An 81-page (1978) guideline presenting recommended personnel concepts; related

specifically to architectural firms. Paperback, \$8/\$10.

***The Photography of Architecture and Design: Photographing Buildings, Interiors and the Visual Arts** (3M333)

In this 240-page book (1977) Julius Shulman shows how to become an architectural photographer. Describes how to obtain the best composition possible by building the right relationship between design elements and structural surfaces. \$22.50/\$25.

***Planning Flexible Learning Places** (3M118)

The authors of the 183-page book (1977), Stanton Leggett and others, have combined their knowledge and experience to help the design professional understand the educator's needs and help the educator visualize the kinds of things that can be done to provide a better environment for learning. \$20.25/\$22.50.

***Planning the New Office: From Feasibility Study to Move-in for Managers and Planners** (3M390)

This reference (1978) by Michael Saphier provides a comprehensive overview of the total effort involved in creating a new office. The role of each specialist concerned with office planning projects is described, with concise details of responsibilities, coordination and control. There is a checklist of everything that may be necessary during the planning process. \$19.50/\$21.50.

***Problem Seeking: An Architectural Programming Primer** (3M277)

Written by William Peña, FAIA, this 202-page book (1977) offers a comprehensive definition of design methodology and process. Tells how to evaluate the programming package, decide on new automated techniques, draw analysis cards and brown sheets and how to conduct interviews and work sessions. Includes case studies, a checklist of key words and a glossary. \$14.50/\$15.95.

***Professional Construction Management and Project Administration** (3M121)

125-page book (second edition, 1976) by William B. Foxhall, looking at professional services and who provides them. \$22.50/\$25.

***ProFile/The Official AIA Directory of Architectural Firms, 1980 Edition** (4M310)

Edited by Henry W. Schirmer, AIA, this 816-page volume (1980) presents a detailed description of architectural firms in America. More than 8,000 firms are grouped and cross-referenced. Included are names of the principals of firms, current and projected work volume by building type and the geographic area of each firm's practice. \$85/\$96.

Project Delivery Approaches: An AIA Guide (2M702)

30-page publication (1976) edited by David S. Haviland of the AIA project management systems task force. This guide is essentially a primer and is planned as the nucleus and framework for AIA development of a series of studies and guidelines for responsive and creative project delivery approaches. \$3.25/\$4.

***Public Art: New Directions** (3M488)

Edited by Louis G. Redstone, FAIA, this 256-page book (1980) features examples of public art in the built environment. Provides data on each example, including location, names of architect/artist, material type and dimensions. \$31.25/\$34.50.

***Public Relations for the Design Professional** (3M455)

278-page book (1979) by Gerre Jones, Hon. AIA, explores the tools and techniques for planning, researching, implementing and evaluating an effective public relations program that fits the needs of the design profession. Proven how-to's are given on: budgets, exhibits, television, seminars, effective writing for press releases and more. \$22.25/\$24.50.

SOUNDBLOX[®]

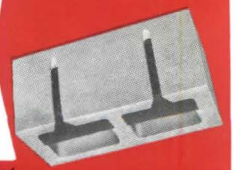

Sound-Absorbing Structural Masonry Units

CONTROL NOISE

See Sweet's General Building (Architectural) or Industrial Construction Files (9.1/P) or Spec-Data, or phone us collect. Nationwide availability... made near your jobsite!



The Proudfoot Company, Inc.

ENVIRONMENTAL PRODUCTS

P.O. BOX 1537, GREENWICH, CONNECTICUT 06830 A/C 203 869-9031

***Pyramid (3M282)**
80-page text (1975) by David Macaulay follows the intricate step-by-step process of the building of an ancient Egyptian pyramid and the complex of surrounding temples and tombs. \$9/\$9.95.

R

***Recreation Planning and Design (3M468)**
Written by Seymour Gold, this 247-page reference (1980) focuses on practical methods that can be applied in park design and planning, including case studies describing various aspects of leisure designs that meet people's needs. \$28.75/\$31.95.

***Regional Guidelines for Building Passive Energy Conserving Homes (3M461)**
Prepared by AIA Research Corporation for HUD and DOE, this 312-page book (1980) gives guidelines for designing houses in 13 general climate regions based on four factors: temperature, humidity, wind and sun. \$6.50/\$7.

***The Restoration Manual (3M115)**
181-page book (1966) by Orin M. Bullock Jr., FAIA, on how to "read" older

structures in order to preserve and reconstruct them in a manner compatible with their original design and construction. \$12.75/\$13.95.

***Roofing Concepts/Principles: A Practical Approach to Roofing, Second Edition (3M458)**

Prepared by Paul Tente Associates, this 71-page guide (1980) provides a functional, working aid in the determination of roofing materials or systems for any structure. \$16.25/\$18.

***Running an Office for Fun and Profit (3M394)**

116-page "how-to" book (1978) by Roslynn Foote on managing the finances of small design firms. The options given in this book have been developed because of, and as a result of, financial management seminars given by the author. \$13.50/\$15.

S

***Simplified Energy Design Economics (3M499)**

Harold E. Marshall and Rosalie T. Ruegg prepared this 50-page book (1980) for the Center for Building Technology, Na-

tional Bureau of Standards. It is a comprehensive guide to basic economic concepts and provides tools for solving simple economic problems. \$3.50/\$4.

***Simplified Guide to Construction Management for Architects and Engineers (3M239)**

288-page book (1976) by James Gorman covers state-of-the-art CM procedures plus potential developments in today's increasingly complex building projects. Sample contract documents, field reports and project case histories simplify planning and organization of CM services within existing design construction organization. \$16.25/\$17.95.

***Site Planning Standards (3M360)**

A comprehensive, 351-page information source, this book (1977) by Joseph DeChiara and Lee E. Koppelman provides a graphic approach to land use. Includes information on the design process from the predesign stage of data inventory and surveys through the analysis of site conditions and the design of plans with specific site details. \$29.75/\$32.95.

Solar Architecture (3M234)

This 350-page book (1976), prepared by the Association of Student Chapters/AIA, is an excellent, photo-illustrated

ARCHITECTS, did you know that Thiokol/Specialty Chemicals Division publishes a newsletter . . . News About Insulating Glass?

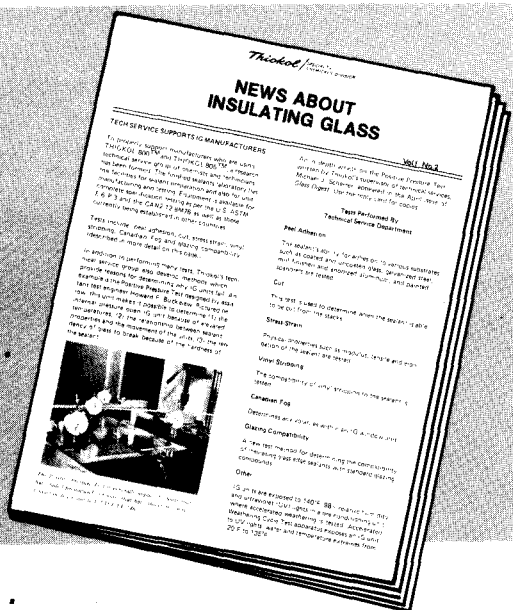

It features . . .

- the IG Corner, a question and answer column for insulating glass manufacturers, and people who specify insulating glass
- industry news, literature, announcements and much more.

If you would like to receive this newsletter, write: Thiokol/Specialty Chemicals Division, IG Mktg. Comm., Dept AIA, Box 8296, Trenton, NJ 08650.

Thiokol / SPECIALTY CHEMICALS DIVISION

Circle 50 on information card

AN OPEN CALL FOR ENTRIES IN THE CRSI DESIGN AWARDS.

Modest or monumental can win.

You could be the proud recipient of one of the coveted awards to be presented in the Sixth CRSI Design Awards Program.

If you're a registered architect or engineer, you owe it to yourself to enter CRSI Design Awards VI.

These Awards honor creative design achievement in reinforced concrete construction and they bestow national recognition on their recipients. Winners will be honored at

CRSI National Convention at the Greenbriar, White Sulphur Springs, W. Virginia.

Your structure must be of cast-in-place reinforced concrete, using conventional reinforcing bars as the principal reinforcement. Structure must have been completed since January 1, 1979 or essentially completed by November 1, 1981. Program is A.I.A.-endorsed and rules are equally simple.

Please send me the Guide for Entries in CRSI Design Awards VI.

NAME _____ TITLE _____
 FIRM _____
 ADDRESS _____
 CITY _____ STATE _____ ZIP _____
 PHONE (____) _____



Mail to: **CONCRETE REINFORCING STEEL INSTITUTE**
 180 North LaSalle Street, Room 2111D, Chicago, Illinois 60601
 Attention: Vice President/Marketing & Promotion
 Phone: 312/372-5059



Circle 46 on information card

reference full of material on the history, components, natural context, research and the future of solar design. A result of the ASC/AIA annual forum held in Tempe, Ariz., November 1975, it is a comprehensive collection of expert presentations and panel discussions. Attendees included many of the nation's leading architects and researchers in the field. \$10.75/\$12.

***Solar Dwelling Design Concepts**
(3M256)

Prepared by AIA Research Corporation, this 146-page report (1976) is an introduction to solar heating and cooling, funded by HUD to help demonstrate the feasibility of solar technology. Includes: description of solar components and full systems, discussion of environmental factors and design concepts and case studies. Paperback, \$4.50/\$5.

***Solar Energy and Housing Design**
(3M356)

By Giffels Associates, Inc., Detroit. Presents a systematic process for selection of solar energy systems applicable to four climatic regions of the continental U.S. and incorporation of these systems into lowrise, multifamily dwellings. Includes a survey of solar collection and

storage components. Paperback, 145 pages, \$13.50/\$15.

***Solar Energy: Fundamentals in Building Design** (3M303)

This 304-page book (1977) by Bruce Anderson, AIA, is a comprehensive treatment of the rationale, design and construction of buildings utilizing solar energy. Treats ways of handling solar energy in building design. \$26.75/\$29.50.

***Solar Heating Design by the f-Chart Method** (3M312)

200-page book (1977) by William Beckman and others provides a practical method for combining a solar collector to heat either liquid or air, an energy storage unit (a water or pebble bed) and a conventional auxiliary furnace or heater into one economical system to supply the entire heating load. Covers sizing solar space or water heating systems, utilizing the solar collector, storage tank and all associated equipment. \$20/\$22.

***Specifications for Commercial Interiors: Professional Liabilities, Regulations, and Performance Criteria** (3M457)

S. C. Reznikoff brings together critical information on health and safety regulation, liability and specification considerations in an interior design practice. This

304-page book (1979) examines six regulatory areas, relevant interior subsystems and the specification technology peculiar to interior design. Of particular importance is the extensive glossary. Illustrated. \$26.75/\$29.50.

Standardized Accounting for Architects (2M705)

First published in 1950, this 153-page manual, revised in 1978, brings the accounting system presented into conformity with the entire AIA financial management system. It is designed to provide a simple recordkeeping procedure that will yield appropriate financial data for routine tax and accounting purposes and for monitoring the operations of a firm. The double-entry system of bookkeeping employed allows the use of either the cash basis or the accrual basis for accounting. Subjects covered include: basic accounting principles, standardized accounting procedures, the basis system and the cash journals, among others. A glossary of terms is provided. \$16/\$20.

***Sun Angles for Design** (4M362)

Robert Bennett, author of this 77-page book (1978), presents sun angle data in an understandable and easily usable form. Charts simulate the sun's motion across

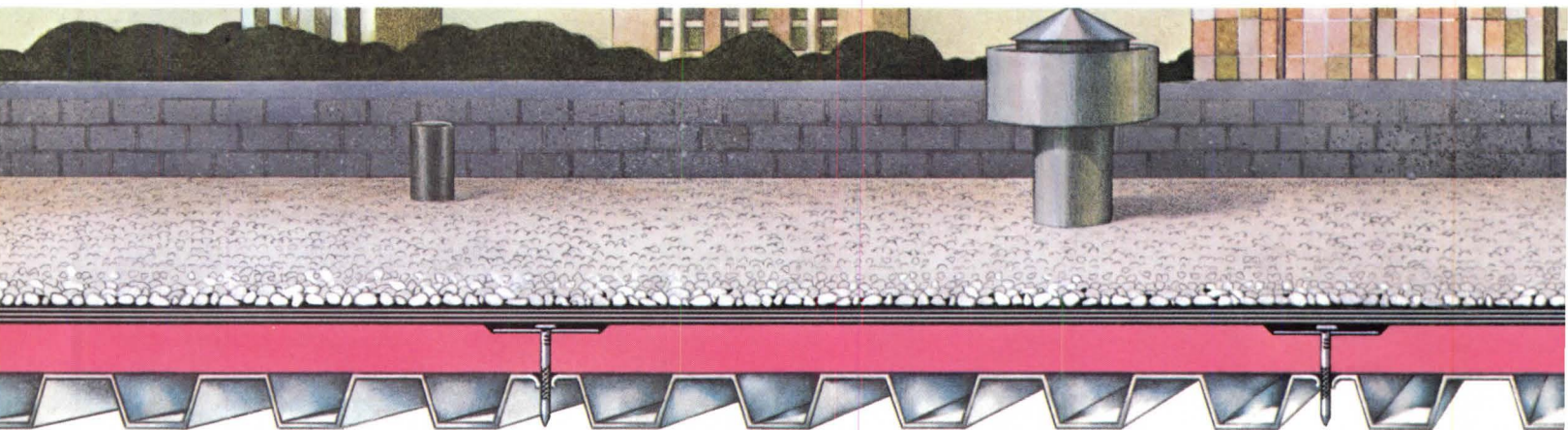

WHAT THE BEST INSULATED ROOFS

THE PINK STUFF: Thermax.[®] It is simply the most efficient roof insulation on the market with a Factory Mutual Class I Fire Rating over steel decks. Thermax provides more insulating efficiency per inch than fibrous glass, composite, perlite or fiberboard roof insulations. Since mechanical fastening is the preferred system of attachment to steel decks, use Insulfast rapid fastening nail/disc system – a pneumatic gun and oxide-coated nails for fast, easy, permanent installation of Thermax to steel decks.

the sky and show its position for any time of the day and any day of the year. Paperback, \$6.25/\$7.

***Sun/Earth: How to Apply Free Energy Sources to Our Homes and Buildings** (3M150)

232-page book (1976) by Richard L. Crowther, AIA, presents in nontechnical language a survey of architecture and its relation to the natural environment and shows how to create comfortable living situations while conserving fossil fuels. \$12.75/\$13.95.

Survey of Passive Solar Buildings (4M264)

Prepared by AIA Research Corporation for HUD, this 177-page publication (1978) documents the state of the art in passive solar design in the U.S. It offers a working definition and a basic understanding of a number of existing applications of passive solar designs. A reference bibliography is included. \$8.

***Systems Drafting: Creative Reprographics for Architects and Engineers** (3M462)

Author Fred Stitt covers such drafting techniques as functional, applique, composite, overlay, office copier and computer; plus standard details and keynoting. 256 pages (1980). \$19.75/\$21.95.

T

***Ten by Warren Platner** (4M276)

224-page volume (1975) presents 10 projects by Warren Platner, FAIA. \$15.

***Theater Design** (3M281)

George Izenour, in this 480-page book (1977), introduces general terminology, types of theater design, detailing and defining auditoriums, stages, sight and hearing lines, and the basics necessary to an appreciation of theater design. Concert halls, with their specific acoustical characteristics, are covered. \$126/\$140.

***Trees for Every Purpose** (3M471)

A 229-page guide (1980) that covers the best North American trees for landscaping—with their vital data from silhouette to soil preference, growing preference and location problems. \$22.50/\$24.95.

U

***Unbuilding** (3M474)

David Macaulay provides a new perspective to a familiar American building—the “unbuilding” of the Empire State Building. 80 pages (1980). \$9/\$9.95.

***Underground** (3M283)

This 112-page book (1976) is David Macaulay's exploration of the complicated below-ground life-support systems: water, electricity, gas, telephone. Traces the structure of skyscrapers, follows sewage and drainage lines and explains the construction of a subway. \$10/\$10.95.

W

Working in Government: A Profile Study of the Architect as a Public Employee (2M712)

Prepared by the AIA architects in government committee (1978), the information presented in this report is intended to give the general public a better understanding of the various functions performed by architects in government; to give educators a clearer view of educational needs and opportunities, and government administrators an opportunity to make comparative assessments of architects in various agencies and at various levels of government. Developed from a survey of more than 2,000 architects, it provides a profile of persons practicing as architects in the public sector. \$5/\$6.

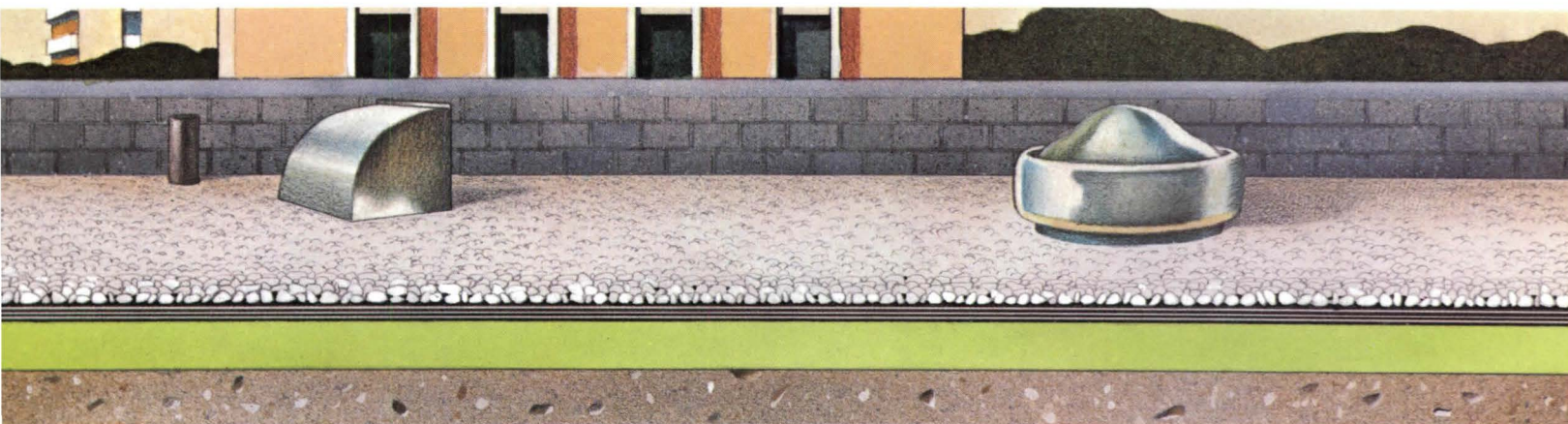

ARE WEARING THESE DAYS.

THE GREEN STUFF: Tempchek® It gives you the same high R-values as Thermax, and is used on all types of decks, except directly over steel decks. Tempchek is the only urethane foam roof insulation reinforced with glass fibers. It has greater dimensional stability than the others, so it resists “growth” and ridging. All of which makes Tempchek first choice for any application other than directly over steel. Talk to your Celotex representative about the stuff the best insulated roofs are wearing these days, or call Ed Levin at Celotex, Roofing Products Division: (813) 871-4545.

Celotex
a Jim Walter company

Circle 52 on information card

AIA JOURNAL/MID-AUGUST 1981 135

The following firms and AIA component offices are official distributors for AIA contracts and forms. If you reside in one of the states marked with an asterisk (*), your document order should be directed to your authorized distributor.

***Alabama**

Birmingham

Birmingham Chapter/AIA
1105 S. 20th St. 35205
(205) 933-1934

Mobile

Bidgood Stationery Co.
68 Saint Francis St. 36601
(205) 433-3731

Mobile Chapter/AIA

c/o Southern Blueprint and Supply, Inc.
2200 Government St. 36606
(205) 473-8667

Montgomery

Montgomery Chapter/AIA
415 Washington Ave. 36104
(205) 264-3037

Alaska

Anchorage

Alaska Chapter/AIA Document Service
c/o Alaska Professional Design Council
2515 A St. 99507
(907) 276-2834

***Arizona**

Phoenix

Arizona Society of Architects
313 E. Thomas Road, Suite 3 85012
(602) 241-0874

Tucson

Southern Arizona Chapter/AIA
4901 E. Fifth St. #206 85711
(602) 881-1777

Arkansas

Fort Smith

Fort Smith Section/AIA
1888 Building
302 N. Sixth Ave., Suite A 72901
(501) 782-1051

Little Rock

Shepherd's
603 W. Markham St. 72201
(501) 375-6937

***California**

Fresno

San Joaquin Chapter/AIA
3033 E. Yale 93703
(209) 266-0389

Long Beach

Cabrillo Chapter/AIA
121 Linden Ave. 90802
(213) 432-9817

Los Angeles

Los Angeles Chapter/AIA
Pacific Design Center
8687 Melrose 90069
(213) 659-2282

Oakland

East Bay Chapter/AIA
315 14th St. 94612
(415) 893-6834

Sacramento

Central Valley Chapter/AIA
1025 19th St., Suite 8 95814
(916) 444-3658

San Diego

San Diego Chapter/AIA
233 A St., Suite 207 92101
(714) 232-0109

San Francisco

San Francisco Chapter/AIA
790 Market St., Third Floor 94102
(415) 362-7397

Santa Ana

Orange County Chapter/AIA
Mercantile Building
3850 S. Plaza Drive 92704
(714) 557-7796

Santa Barbara

Santa Barbara Chapter/AIA
P.O. Box 2381 93120
(805) 965-6307

Santa Clara

Santa Clara Valley Chapter/AIA
1333 Lawrence Expressway 95051
(408) 249-1515

***Colorado**

Boulder

Ridgway's
839 Pearl St. 80302
(303) 444-3390

Denver

Capitol Hill Blueprint Service
1634 18th St. 80202
(303) 892-9593
Colorado Society of Architects
1420 Larimer Square 80202
(303) 629-0759

***Connecticut**

East Hartford

Cleaveland Legal Blank Service Inc.
66 Connecticut Boulevard 06108
(203) 289-5446

Farmington

Crest Blueprint Service Inc.
220 Farmington, Ave. 06032
(203) 677-8817

New Haven

Connecticut Society of Architects
85 Willow St. 06511
(203) 865-2195

Delaware

Wilmington

Wilmington Blueprint Service
2704 W. Third St. 19805
(302) 652-3364

***Florida**

Fort Lauderdale

Broward County Chapter/AIA
519 N.E. Third Ave. 33301
(305) 763-7216

Jacksonville

A. R. Cogswell Blueprint
738-800 N. Myrtle Ave. 32204
(904) 356-4271

Jacksonville Chapter/AIA Bookworks

One Independent Square
Independent Life Building 32202
(904) 355-8533

Miami

Florida South Chapter/AIA
P.O. Box 647 33145
(305) 221-5615

Tallahassee

Florida Association of Architects
117 W. College 32302
(904) 222-7590

***Georgia**

Albany

Dougherty Blueprint & Supply Co.
420 N. Cleveland St. 31702
(912) 435-5727

Atlanta

Ivan Allen Co.
P.O. Box 1712 30301
(404) 521-0800
Atlanta Blueprint & Photo
Reproduction
1052 Peachtree St. 30309
(404) 873-5911
Atlanta Chapter/AIA Architectural
Book Center, Peachtree Center,
Cain Tower Lobby
229 Peachtree St. N.E. 30303
(404) 524-3877
Georgia Blueprint Co.
119 Luckie St. N.W. 30303
(404) 524-8881

Columbus

Siegel Reproduction & Supply Co.
1200 13th St. 31902
(404) 324-1373

Savannah

Savannah Blueprint Co.
11 E. York St. 31401
(912) 232-2162

***Hawaii**

Honolulu

Hawaii Society of Architects
233 Merchants St., Suite 200 96813
(808) 538-7276

Sources for AIA Contracts and Forms

*Idaho

Boise

Idaho Chapter/AIA
842 La Cassia Drive 83705
(208) 345-1730

*Illinois

Chicago

Chicago Chapter/AIA
53 W. Jackson, Suite 346 60604
(312) 663-4111

Moline

Tri-City Blueprint Co.
1615 Third Ave. 61265
(309) 764-2478

*Indiana

Indianapolis

Architectural Center/Indiana Society
of Architects
148 N. Delaware 46204
(317) 634-3871
Marbaugh Engineering Supply
121 W. North St. 46204
(317) 632-4322

*Iowa

Des Moines

Iowa Chapter/AIA
512 Walnut St. 50309
(515) 244-7502

*Kansas

Topeka

Kansas Society of Architects
724 Kansas Ave. 66603
(913) 357-5308

Wichita

City Blueprint Inc.
1200 E. Waterman 67201
(316) 265-6224

*Kentucky

Lexington

Lynn Blue Print & Supply Co.
327 E. Vine St. 40507
(606) 255-1021

Louisville

Central Kentucky Chapter/AIA
c/o Becky Biesel
2239 Milvale Road 40205
(502) 459-4441
St. Matthews Blueprint & Supply Co.
131 St. Matthews Ave. 40207
(502) 895-2467

*Louisiana

Baton Rouge

Louisiana Architects Association
830-A North St. 70802
(504) 387-5579

*Maryland

Baltimore

Building Congress and Exchange
2301 N. Charles St. 21218
(301) 235-4161
Lucas Brothers Inc.
7700 Port Capital Drive 21227
(301) 685-3000

*Massachusetts

Boston

Boston Blueprint Co., Inc.
777 Boylston St. 02116
(617) 267-2490
Boston Society of Architects
320 Newbury St. 02115
(617) 267-5175
Hobbs & Warren Inc.
80 Summer St. 02101
(617) 542-7947
Andrew T. Johnson Co.
15 Tremont Place 02108
(617) 742-1610
B. L. Makepeace Inc.
1266 Boylston St. 02215
(617) 267-2700

Woburn

Charrette Corporation
31 Olympia Ave. 01801
(617) 935-6121

*Michigan

Detroit

Michigan Society of Architects
553 E. Jefferson Ave. 48226
(313) 965-4100

Grand Rapids

Bixby Office Supply Co.
357 36th St. S.E. 49508
(616) 452-3213

*Minnesota

St. Paul

Architectural Book Center/Minnesota
Society of Architects
402 Northwestern Skyway Building
55101
(612) 227-0761

*Mississippi

Jackson

Mississippi Chapter/AIA
P.O. Box 12515 39211
(601) 981-9327

*Missouri

Kansas City

Kansas City Chapter/AIA
20 W. Ninth St. 64105
(816) 221-3485

St. Louis

St. Louis Chapter/AIA
919 Olive St. 63101
(314) 621-3484

THE CO-RAY-VAC[®] HEATING SYSTEM

So energy efficient it cuts fuel usage up to 50% and more!

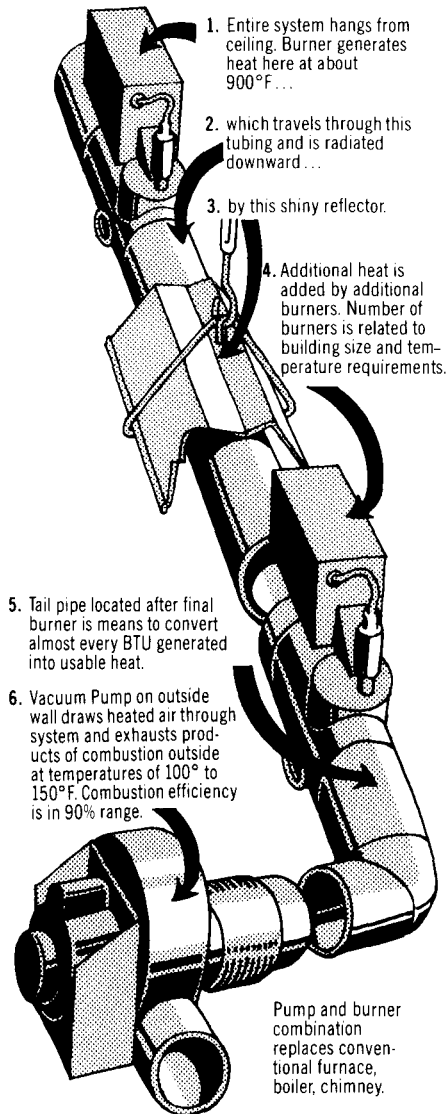

1. Entire system hangs from ceiling. Burner generates heat here at about 900°F...
2. which travels through this tubing and is radiated downward...
3. by this shiny reflector.
4. Additional heat is added by additional burners. Number of burners is related to building size and temperature requirements.

5. Tail pipe located after final burner is means to convert almost every BTU generated into usable heat.
6. Vacuum Pump on outside wall draws heated air through system and exhausts products of combustion outside at temperatures of 100° to 150°F. Combustion efficiency is in 90% range.

Pump and burner combination replaces conventional furnace, boiler, chimney.

- Gas-fired system designed for industrial and commercial buildings.
- Users report fuel reductions up to 50% and more.
- Ceiling hung system warms people and objects with even, draftless heat.
- Warm floors mean warm feet... happy employees.
- Fast heat recovery after opened doors are closed.
- Life-cycle cost analysis tells you what original cost and operating costs will be.
- Unique design features.

CO-RAY-VAC... The original radiant infrared heating system proved in thousands of buildings since 1962.



Roberts-Gordon

Appliance Corporation
Subsidiary of A.J. Industries, Inc.
44 Central Ave., Buffalo, N.Y. 14206
Phone 716/892-8400

Circle 54 on information card

*Montana

Billings
Montana Chapter/AIA
P.O. Box 20996 59104
(406) 259-7300

*Nebraska

Omaha
Nebraska Society of Architects
1910 S. 44th St. 68105
(402) 556-8506
Standard Blue Print Co.
10011 J St. 68127
(402) 592-5900

Nevada

Las Vegas
Construction Notebook
3599 S. Polaris 89103
(702) 876-8660
Reno
Northern Nevada Chapter/AIA
Document Service
c/o Raymond Hellman, AIA
137 Vassar St., Suite 8 89502
(702) 329-7049

New Hampshire

Concord
New Hampshire Chapter/AIA
43 S. State St. 03301
(603) 228-1231

*New Jersey

Camden
Allen Reproduction Co.
800 Market St. 08102
(609) 365-5787
Woodbridge
New Jersey Society of Architects
1000 Route Nine 07095
(201) 636-5680

*New Mexico

Albuquerque
New Mexico Society of Architects
67 First Plaza/Galleria 87102
(505) 842-8744

*New York

Albany
Eastern New York Chapter/AIA
13 Northern Boulevard 12210
(518) 465-3191
New York
New York City Chapter/AIA
457 Madison Ave. 10022
(212) 838-9670
Old Westbury
Long Island Chapter/AIA
c/o ASC/AIA
New York Institute of Technology
Wheatley Road 11568
(516) 249-7370

Rochester

Rochester Chapter/AIA
130 Spring St., Second Floor 14608
(716) 232-7650

*North Carolina

Charlotte
Pound & Moore
304 S. Tryon St. 28201
(704) 375-7751
Southern Photo Print Supply Co.
201 Rampart St. 28200
(704) 332-2154

Durham

Southern Photo Print Supply Co.
115 E. Parrish 27701
(919) 682-5098

Fayetteville

Southern Photo Print Supply Co.
314 E. Russell St. 28301
(919) 483-4909

Greensboro

Southern Photo Print Supply Co.
1639 Spring Garden St. 27402
(919) 274-1541

High Point

Southern Photo Print Supply Co.
340 N. Wrenn St. 27260
(919) 882-3127

Raleigh

North Carolina Chapter/AIA
115 W. Morgan St. 27601
(919) 833-6656

Raleigh Blue Printers
213 W. Martin St. 27601
(919) 832-2841

Wilmington

Southern Photo Print Supply Co.
923 N. Third St. 28401
(919) 762-9617

North Dakota

Fargo

Mathisons
1213 Northern Pacific Ave. 58102
(701) 232-8971

*Ohio

Cincinnati

Cincinnati Chapter/AIA
602 Main St., Suite 1114 45202
(513) 421-2657

Cleveland

City Blueprinting Co.
1937 Prospect Ave. 44115
(216) 241-7344
Cleveland Chapter/AIA
210 The Arcade
401 Euclid Ave. 44114
(216) 771-1240

Columbus

Architects Society of Ohio
37 W. Broad St. 43215
(614) 221-6887

NEW SPlice LOCK™ ROOF EDGING

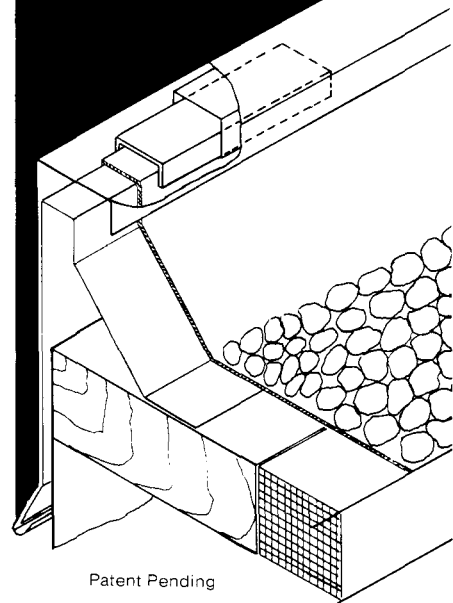

Cheney SPlice LOCK roof edging is designed specifically for adhered or ballasted single ply roofing systems.

SPlice LOCK saves material and installation costs. The three piece system is furnished complete with galvanized steel water dam that anchors—and gives positive support—to both fascia and roof flange. A spring loaded, concealed splice plate supports and locks the .040 aluminum exterior fascia in place. Three fascia sizes are available in a choice of Cheney color finishes. Write or call for complete data.

A company in touch with your needs.

CHENEY
FLASHING COMPANY

623 Prospect Street, Box 818
Trenton, N.J. 08605
Phone (609) 394-8175

Circle 55 on information card

AIA JOURNAL MID-AUGUST 1981 139

South Carolina

Charleston
Charleston Blueprint & Supply
284 E. Bay St. 29402
(803) 722-1617

Columbia
Capital Blueprint Co.
2730 Millwood Ave. 29205
(803) 254-2561

Florence
Pee-Dee Blueprint Co.
484 W. Palmetto St. 29501
(803) 669-5341

Greenville
Piedmont Printmakers & Supply
353 W. McBee Ave. 29602
(803) 233-5371

South Dakota

Rapid City
Rapid City Builders and Exchange
907 Jackson Boulevard 57701
(605) 343-5252

Sioux Falls
Mathisons
155 S. Indiana 57701
(605) 232-8971
South Dakota Society of Architects
2204 S. Holly Ave. 57105
(605) 338-2073

*Tennessee

Knoxville
Knoxville Blueprint & Supply Co.
622 Leroy Ave. 37921
(615) 525-0463

Memphis
Builders Exchange of Memphis
642 S. Cooper St. 38104
(901) 272-7495

Nashville
Nashville Blueprint & Supply
908 Division St. 37203
(615) 259-2230

Tennessee Society of Architects
223½ Sixth Ave. N. 37219
(615) 256-2311

*Texas

Austin
Texas Society of Architects
2121 Austin National Bank Building
78701
(512) 478-7386

Dallas
Dallas Chapter/AIA
2800 Routh, Suite 141 75201
(214) 748-4264

Houston
Houston Chapter/AIA
2003 W. Gray 77019
(713) 520-8125

continued on page 142

Dayton

Dayton Blueprint Co.
222 N. Saint Clair St. 45402
(513) 223-2272

Toledo

Toledo Blueprint and Paper Co.
617 Adams St. 43604
(419) 243-7224

*Oklahoma

Oklahoma City
Oklahoma Chapter/AIA
405 N.W. 15th St. 73103
(405) 525-7897

Tulsa

Tulsa Chapter/AIA
2210-R S. Main St. 74114
(918) 583-0013

*Oregon

Portland

Portland Chapter/AIA
519 S.W. Third Ave. 97204
(503) 223-8757
Stevens-Ness Law Publishing
916 S.W. Fourth St. 97204
(503) 223-3139

*Pennsylvania

Harrisburg

Harrisburg Blueprint
204 Locust St. 17101
(717) 232-3096
Pennsylvania Society of Architects
P.O. Box N 17105
(717) 236-4055

Philadelphia

Philadelphia Chapter/AIA
117 S. 17th St. 19103
(215) 569-3186

Pittsburgh

Pittsburgh Chapter/AIA
1612 Benedum-Trees Building 15222
(412) 471-9548

Scranton

Reynolds Brothers Inc.
138 N. Washington Ave. 18503
(717) 342-8205

Williamsport

Plankenhorn Stationery Co.
144 W. Fourth St. 17701
(717) 326-2676

*Rhode Island

Providence

Rhode Island Chapter/AIA
150 Pine St. 02903
(401) 272-6418



**In a setting such as this,
who could blame you for hiding
the cooling tower?**

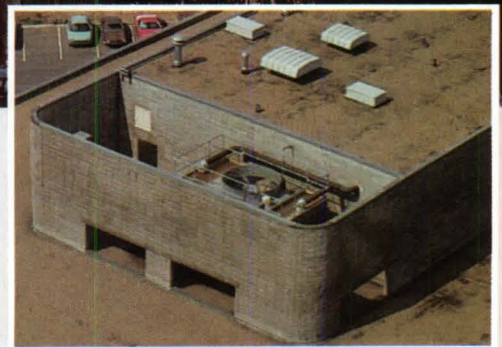

We wouldn't. Even when they're our towers, such as those installed in Kansas City's Corporate Woods.

You see, we design our cooling towers on the principle that form follows function. Which is just as it should be. And while that may not make them look especially beautiful, it does make them function beautifully.

Even behind properly designed architectural enclosures, like the one atop this building. Or hundreds of similar enclosures you pass every day without suspecting there's a Marley tower inside.

The point? Simply this: With a Marley cooling tower and a little aesthetic wizardry, you can have the harmonious look of a custom-built tower at substantial savings.

And that's also beautiful.

The Full Service Cooling Tower Company



Think of it as an investment in your market ability.



“Energy in Architecture” 50 Fall 1981 Workshops

Over the past decades, from 1955 to 1975, energy consumption for the operation of buildings in the United States nearly doubled, from 9.5 to 17.3 quadrillion Btu per year.

Buildings consume nearly 40 percent of all U.S. energy. More than 50 percent of that consumption: More than industry, more than anything else. And as energy costs keep going up, the need to conserve energy grows.

Learn how to meet a building's energy needs with the most effective energy conservation techniques available.

To help design professionals throughout the country meet this demand, the American Institute of Architects has developed “Energy in Architecture,” the most comprehensive professional development program in the field.

The program is included in levels of professional development in workshops that meet your specific needs in terms of

acquiring up-to-date knowledge and design skills.

Level 1: Techniques is a two-day, 16-hour workshop focusing on design fundamentals, techniques, and options as they relate to energy use.

Level 2: Process is a two-day workshop for the design professional that covers the integration of energy conservation techniques in the design process.

Level 3: Practice is a two-day seminar that provides a design program for a real building.

Fall workshops are scheduled in 29 states. Send now for a complete list of locations and workshop descriptions.



Brenda Henderson
Professional Development
The American Institute of Architects
1735 New York Avenue, N.W.
Washington, D.C. 20006

Please send me information on the 50 Fall 1981 “Energy in Architecture” Workshops.

Name _____

Title _____

Firm _____

Address _____

City _____

State _____ Zip _____

THE PROTECTOR

Need an operable wall?

SIX IMPORTANT REASONS TO CONSIDER

R-W

STEELWALL

- 1 DIRECT FACTORY SALES FORCE**
Operating from our nationwide network of branch offices, R-W salaried sales engineers have the in-depth knowledge and experience to give you accurate on-the-spot answers, recommendations and problem solving solutions.
- 2 QUALITY**
Compare the engineering, materials and craftsmanship of R-W doors and hardware and you'll know why R-W is known as the industry's finest.
- 3 NFPA CLASS A FIRE RATING**
- 4 CLASS G 48-52 STC SOUND LEVEL RATING**
- 5 SUPER DURABLE**
... and it is virtually maintenance free! The R-W STEELWALL resists abuse that would severely damage other doors.
- 6 BROADEST LINE**
Choose from the industry's most comprehensive line of doors and hardware. Manual or automatic.



Richards-Wilcox

MANUFACTURING COMPANY
223 THIRD STREET • AURORA, ILLINOIS 60507
One of the White Consolidated Industries

Have a factory sales-engineer call me. Name _____ Company _____

Provide me with detailed catalog A-603. City _____ State _____ Zip _____ Phone _____

Sources from page 139

Ridgway's
4102 Greenbriar 77098
(713) 782-8580

San Antonio

San Antonio Chapter/AIA
306 N. Presa, Suite 8 78205
(512) 226-4979

Paul E. Anderson Co.
3485 Fredericksburg Road 78201
(512) 743-8111

***Utah**

Salt Lake City
Utah Society of Architects
555 E. South Temple 84102
(801) 532-1727

Vermont

Charlotte
New England Book Service 05445
(802) 425-2461

Virginia

Charlottesville
Mint Printing & Supply Co.
510 E. Westfield Road 22901
(804) 973-4408

Richmond

R. R. Sharpless Co., Inc.
7 E. Cary St. 23220
(804) 643-8491

Virginia Reproduction & Supply
9 W. Cary St. 23220
(804) 643-9116

Virginia Beach

Tidewater Chapter/AIA
4249 Cheswick Lane 23455
(804) 499-4485

***Washington**

Seattle

Seattle Chapter/AIA
1911 First Ave. 98101
(206) 622-4938

Spokane

J. A. Gendron Co.
1012 N. Washington 99201
(509) 326-4490

***West Virginia**

Huntington

Traco
826 Sixth Ave. 25701
(304) 529-1388

South Charleston

West Virginia Society of Architects
1016 Knob Way 25309
(304) 768-6675

***Wisconsin**

Madison

Wisconsin Society of Architects
615 E. Washington Ave. 53703
(608) 257-8477

How Acrovyn® gives you more for your wall protection dollar

After more than a decade as the recognized leader in wall protection systems, our Acrovyn products are beginning to be imitated. A compliment perhaps. But, dollar for dollar the imitators can't match Acrovyn's proven combination of functional, safety and convenience features.

Different By Design

Our Acrovyn system components are as different from today's imitators as they are from yesterday's *unyielding* wood and steel corner guards and handrails.

Because only Acrovyn gives you genuine *free-floating action*:



the secret's in its unique combination of a metal retainer and tough vinyl/acrylic guard that actually moves as it absorbs shocks that could permanently damage other systems.

A not so obvious Acrovyn advantage is the guard's vinyl/acrylic formulation which has impact resistance up to 33% greater than the ordinary P.V.C. used by competitors.

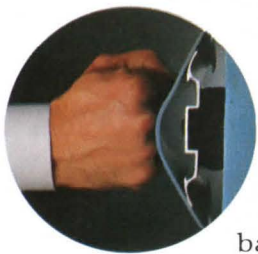

Germicidal Additives

Surface bacteria control hasn't been neglected either. Thanks to Microban,™ a spe-

cially formulated antibacterial agent, a broad spectrum of bacteria and fungus are killed on contact. A special release mechanism assures that the germicide, which is homogeneously dispersed throughout the plastic mass, will retain its effectiveness for 12 to 15 years of normal use.

Of course, all Acrovyn system surfaces are Class I fire rated—we're not so sure about the competition.

Maintenance That's Easy To Live With

Your institution's housekeeping department will love the way grease, grime and stains wipe off—with ordinary cleansing solutions.

They'll also love the fact that the color goes all the way through,

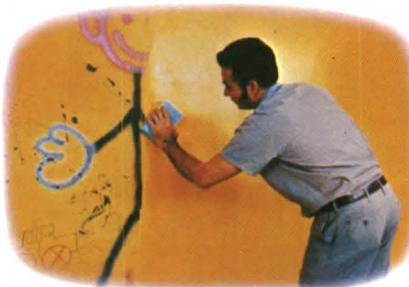

masking cuts and abrasions. Acrovyn cannot chip, peel or crack!

Protection For Every Need

We know of no other wall protection system as complete: corner guards, bumper guards, handrails, crash rails, door protection systems, all keyed to work beautifully with our new

textured wall coverings and *Acroform*™ decorative panels. (*Acroform* is our protective wall system which translates your custom graphics and designs into colorful, 3-D panels.)



Acroform isn't the only colorful part of our system. Every component is available in 26 colors carefully blended by a leading designer to compliment or contrast with today's lively environments.



Our pale competitors may be blushing about that!

If your walls encounter the kind of abuse Acrovyn has been battling successfully for over a decade in thousands of institutions, call us for detailed literature. Or, if you prefer, our representative will be happy to provide you with samples so that you may prove to yourself that *Acrovyn truly gives you more for your wall protection dollar!*

Construction Specialties, Inc. • Muncy, PA. (717) 546-5941 • San Marcos, CA. (714) 744-0300
Mississauga, Ontario (416) 274-3611

Circle 59 on information card

The producers of products, systems, materials and supplies offer various resources, including publications, slide shows, films and design and layout services. Items are free unless a price is indicated. This list was put together from responses received from supplier firms. The content, in edited form, is solely the suppliers'; inclusion here is neither an endorsement nor a commentary on the substance of the resources. The list is organized according to the Uniform Construction Index in 16 categories of product areas.

UCI 1: General Requirements

AM Bruning

Offers literature packets describing the firm's line of computer drafting systems, whiteprinters and drafting furniture. Contact Advertising Manager, AM Bruning, 1834 Walden Office Square, Schaumburg, Ill. 60196.

Bethlehem Steel Corporation

Color video film presentations are available on loan basis. Films offered are "Lessons from Earthquakes," "Philip Johnson: Philosophy of Architecture" and "The Skyscraper—Symbol of Urban Progress." Case history folders with drawings and photographs are provided on the following buildings: Citizens First National Bank Building, Glen Rock, N.J.; Federated Department Stores headquarters building, Cincinnati; Harbor Plaza Yacht Haven East, Stamford, Conn.; IBM Office Building, Southfield, Mich.; Thurlow Terrace Apartments, Albany, N.Y., and Woonsocket Institution for Savings, Woonsocket, R.I. Contact Sales Engineering, Room 253, GSO, Bethlehem Steel Corporation, Bethlehem, Pa. 18016.

Blu-Ray Inc.

Wall chart that illustrates the "Sepia Burn-Out" drafting technique and literature that describes the complete line of whiteprinters are available. Contact Blu-Ray Inc., Essex, Conn. 06426.

BOMA International

Brochures describe seminars, membership, building planning service and publication sales. Contact Building Owners and Managers Association International, 1221 Massachusetts Ave. N.W., Washington, D.C. 20005.

Charette

258-page catalog describes office materials, equipment and furniture for the architect and professional design office. \$2. Contact Charette, 31 Olympia Ave., Woburn, Mass. 01801.

The Construction Specifications Institute Brochure explains the Spec-Data product information system. Construction product data sheets are issued four times a year.

Contact Jim Sigel, CSI, 1150 17th St. N.W., Washington, D.C. 20036.

Conwed Corporation

Offers a 12-page brochure on office environments that shows how furniture components, acoustical panels, ceilings and lighting interact.

Contact Sheila A. Katusky, Advertising Department, Conwed Corporation, P.O. Box 43237, St. Paul, Minn. 55164.

Faber-Castell Corporation

Offers information on Col-erase, erasable color pencils, and TGJ, a sapphire jewel point pen designed for use on polyester drafting film.

Contact Richard Bray, Marketing Manager, Faber-Castell Corporation, P.O. Box 7099, Newark, N.J. 07107.

Intergraph Corporation

Brochure describes current user applications, hardware and retrieval system of the entry level interactive graphics system.

Contact Ben Smith, Intergraph Corporation, One Madison Industrial Park, Huntsville, Ala. 35807.

Koh-I-Noor Rapidograph, Inc.

Literature describes the Rapidograph Technical pen and pen sets with replacement points.

Contact Koh-I-Noor Rapidograph, Inc., P.O. Box 68, Bloomsbury, N.J. 08804.

Kroy Industries Inc.

Information is available on lettering machines that produce instant "type on tape" without chemicals in four typestyles.

Contact Rex Allen, Communications Specialist, Kroy Industries Inc., Dept. 1224, P.O. Box 43716, St. Paul, Minn. 55164.

McGraw-Hill Book Co.

Offers 18-page catalog entitled "Select Architectural and Design Books from McGraw-Hill."

Contact John Stockwell, McGraw-Hill Book Co., 1221 Ave. of the Americas, New York, N.Y. 10020.

R. S. Means Co., Inc.

"Appraisal Manual 1981" contains detailed cost information, feasibility studies and conceptual estimates. \$33. Also available is a catalog of publications.

Contact R. S. Means Co., Inc., 100 Construction Plaza, Kingston, Mass. 02364.

Prime-PM

Offers information on various aspects of commercial and residential property management.

Contact Bonnie Bailey, Prime-PM, 5775 E. Peachtree, Dunwoody Suite 200, Atlanta, Ga. 30342.

Steelcase

Report of a national study of office environments that compared the relationship of comfort to productivity is available.

Contact Steelcase Inc., Grand Rapids, Mich. 49501.

3M

26-page brochure describes construction and maintenance products.

Contact P. L. Sevareid, Public Relations Department, 3M, P.O. Box 33690, St. Paul, Minn. 55144.

UCI 2: Site Work

Continental Custom Bridge Co.

Brochure describes prefab, steel bridges, stairs, ramps, towers and landings.

Contact Neal Hazeltine, Continental Custom Bridge Co., Route 5, Box 178, Alexandria, Minn. 56308.

Conwed Corporation

Offers literature on turf establishment and erosion control products. One brochure explains how Hydro Mulch fibers are an alternative to sod or seeding for commercial/residential projects. Information is also available on the effect of plastic netting in controlling erosion.

Contact Sheila A. Katusky, Advertising Department, Conwed Corporation, P.O. Box 43237, St. Paul, Minn. 55164.

East Marsh Nursery, Inc.

Literature describes acclimatized foliage for interior landscaping.

Contact East Marsh Nursery, Inc., 1990 N. Federal Highway, Dania, Fla. 33004.

Landscape Forms, Inc.

Offers information on the Trestle Group of benches, tables, kiosks and trash receptacles constructed of wrought iron and wood.

Contact Landscape Forms, Inc., Route 3, Kalamazoo, Mich. 49001.

Leslie-Locke

Offers information on ornamental iron custom fencing, railings, columns and other functional and decorative accessories. Brochure describing the collection of ceiling fans is also available.

Contact Leslie-Locke, 2872 W. Market St., Akron, Ohio 44313.

Resources Suppliers from and Manu- facturers

Neenah Foundry Co.

"Construction Castings" is a 320-page catalog detailing curb inlets, trench drains, manhole covers and miscellaneous grates. Contact *J. M. Meyer, Marketing Service Manager, Neenah Foundry Co., P.O. Box 729, Neenah, Wis. 54956.*

Vermont Iron Stove Works, Inc.

Offers literature on Catamount Park benches, porch swings and other cast iron and wood furniture. Information describing wood burning stoves is also available. Contact *Richard H. Travers, Vermont Iron Stove Works, Inc., Box 299, Waterbury, Vt. 05676.*

UCI 3: Concrete

Ad Systems International

Offers information on Vetonit Plaano, a construction material manufactured from industrial waste by-products with features similar to concrete.

Contact *Rand Schulman, Ad Systems International, 200 Gate Five Road, Suite 214, Sausalito, Calif. 94965.*

American Concrete Institute

Catalog lists more than 200 publications on concrete technology, structural design and construction. All ACI standards, codes and specifications are listed.

Contact *the American Concrete Institute, P.O. Box 19150, Detroit, Mich. 48219.*

Concrete Reinforcing Steel Institute

Offers literature on the professional membership program, publication sales and the CRSI design awards. Also available are the Structural Design Guide to ACI Building Code, \$24.95, the CRSI Reinforced Concrete Fire Resistance, \$19.50, and the 850-page CRSI Handbook, \$29. Contact *Victor A. Walther Jr., Vice President, Marketing and Promotion, 180 N. La Salle St., Chicago, Ill. 60601.*

Interlocking Paving Manufacturers Association

Literature describes applications, specifications and maintenance of interlocking concrete pavers.

Contact *Interlocking Paving Manufacturers Association, 5 Bond St., Great Neck, N.Y. 11021.*

Keene Corporation

Brochure describes the company's new line of insulating and finishing cements. Contact *Keene Corporation, Insulation Operation, P.O. Box 2677, 1603 Fulford St., Kalamazoo, Mich. 49003.*

Molded Fiber Glass Concrete Forms Co.

Offers information on fiberglass waffle dome forms, round column forms, one-way pans and beam forms.

Contact *Mike Fortune, Vice President,*

Molded Fiber Glass Concrete Forms Co., 55 Fourth Ave., Union City, Pa. 16438.

Portland Cement Association

Offers for rental or purchase a 16mm film, "Earthquake Problems, Concrete Solutions," that describes the investigation of reinforced concrete wall designs for earthquake resistance. It shows walls bending under simulated seismic loads. Contact *the Order Processing Section, Portland Cement Association, 5430 Old Orchard Road, Skokie, Ill. 60077.*

Prestressed Concrete Institute

Catalog describes manuals, periodicals, committee reports and audiovisual training programs available.

Contact *Prestressed Concrete Institute, 201 N. Wells St., Chicago, Ill. 60606.*

UCI 4: Masonry

Georgia Marble Co.

Offers four 16mm films on a loan basis: "New Face on Capitol Hill," which describes the refacing of the east front of the U.S. Capitol; "Producing America's Buried Treasure," the story of the company; "The Zibell Anchoring System," an explanation of stone erection, and "Marblefaced Precast," which details the production of a marble faced precast panel. Also available are several brochures that show marble varieties and applications. Contact *Carroll L. Bolick, Structural Sales Manager, Georgia Marble Co., Nelson, Ga. 30151.*

Glen-Gery Corporation

"The Innovative Brickmaker" brochure illustrates brick ranges, brick pavers and completed projects. A face brick catalog is also available.

Contact *Steven T. Boback, Marketing Services Department, P.O. Box 1542, Reading, Pa. 19603.*

National Concrete Masonry Association

Catalog includes listing of 300 items on concrete masonry design and construction with illustrations of projects. Provides technical data useful in designing with concrete masonry. Contact *the National Concrete Masonry Association, P.O. Box 781, Herndon, Va. 22070.*

Stark Ceramics, Inc.

Offers a 15-minute slide and tape presentation on applications of structural glazed facing tile. The show details sizes and colors, thermal properties, fire benefits and installation examples.

Contact *C. J. Deimling, Stark Ceramics, Inc., P.O. Box 8880, Canton, Ohio 44711.*

UCI 5: Metals

Architectural Aluminum Manufacturers Association

1981 publication catalog describes the nearly 70 publications available.

Contact the Architectural Aluminum Manufacturers Association, Technical Information Center, 35 E. Wacker Drive, Chicago, Ill. 60601.

Bethlehem Steel Corporation

Four slide presentations are available on loan: "Consideration for Economical Steel-Framed Structures," an evaluation of the estimated frame weight for structures; "Steel in Architecture," a discussion of the challenges of the early '60s; "Steel Framing and the Energy-Efficient Building," a description of the energy-saving features of the IMB Building, Southfield, Mich., and "Strictly Structural," a nontechnical discussion on fabrication and erection of steel buildings and bridges. Also available is literature on rigid-frame beams, column connectors and structural nuts, bolts and washers.

Contact Sales Engineering, Bethlehem Steel Corporation, Bethlehem, Pa. 18016.

Copper Development Association, Inc.

Offers three design handbooks and a 16mm film on loan. Handbooks include "Architectural Applications," "Sheet Copper Applications" and "Solar Energy Systems." A 15-minute film, "Soldering and Brazing the Professional Way," illustrates proper workmanship.

Contact Copper Development Association, Inc., 405 Lexington Ave., New York, N.Y. 10174.

Follansbee Steel Corporation

Offers information on TCS (Terne Coated Stainless Steel) and terne metal (copper-bearing steel coated with a lead/tin alloy.)

Contact Jay F. Carey, Follansbee Steel Corporation, Follansbee, W.Va. 26037.

Reynolds Metal Co.

"The House that Recycling Built" is an audiovisual presentation that compares recycled and new materials in construction of a house. Also available is a 16-page brochure that illustrates commercial roofing and siding products and applications.

Contact Building Products Advertising, Reynolds Metals Co., P.O. Box 27003, Richmond, Va. 23261.

H. H. Robertson

Metal exterior wall panel systems are described in a 12-page catalog entitled "Formawall: Curtain Wall Systems." Contact H. H. Robertson, 400 Holiday Drive, Pittsburgh, Pa. 15220.

Wire Crafters Inc.

Catalog includes engineer drawings, color

photographs and specifications of the 840 style modular wire partitions.

Contact Charles Hagan, National Sales Manager, Wire Crafters Inc., 201 Eiler Ave., Louisville, Ky. 40214.

The Wiremold Co.

Offers brochure that describes plant/warehouse light powering and support systems.

Contact The Wiremold Co., West Hartford, Conn. 06110.

UCI 7: Thermal & Moisture Protection

American Plywood Association

Offers a number of publications, audio-visual aids and services demonstrating the uses of plywood. Publications include "303 Plywood Siding," "Fire-Rated Systems," "All-Weather Wood Foundation" and "Design/Construction Guide: Residential and Commercial." Films available for loan or purchase are "Finishing Plywood Siding," "AWWF in Rapid City," "APA Glued Floor System" and "The Engineered 24-inch Framing System." Films available on a loan basis are "Design vs. Nature's Violence," a 22-minute film showing a plywood structure that withstood the 1964 Alaska earthquake; "Plans Approved," a 27-minute film on the importance of building codes, and "Miracle in Wood," a look at the development of plywood.

Contact Maryann Ezell, Public Relations, American Plywood Association, P.O. Box 11700, Tacoma, Wash. 98411.

Field representatives will supply design professionals with information on plywood and design assistance.

Contact Herman Glover, Director, Field Services Division, American Plywood Association, P.O. Box 11700, Tacoma, Wash. 98411.

California Redwood Association

Two booklets, "Redwood Lumber Grades and Uses" and "Redwood Interior/Exterior Guide" provide information on wood patterns, grades and finishes.

Contact Pamela Allsebrook, California Redwood Association, One Lombard St., San Francisco, Calif. 94111.

Koppers Co., Inc.

Literature is available that describes uses, types and applications of laminated and treated wood.

Contact Koppers Co., Inc., Forest Products Group, 1900 Koppers Building, Pittsburgh, Pa. 15219.

Osmose Wood Preserving Co. of America

Information describes Flame Proof LHC, a fire-retardant for wood products.

Contact William Page, Customer Service Coordinator, Osmose Wood Preserving Co. of America, 980 Ellicott St., Buffalo, N.Y. 14209.

Pacific Lumber Co.

Brochures describe application, uses and product specifications of redwood and douglas fir products.

Contact C. William Stevens, General Sales Manager, The Pacific Lumber Co., P.O. Box 7406—Rincon Annex, San Francisco, Calif. 94120.

Shakertown

Architect's manual includes application drawings, technical data and specification sheets on eight-foot cedar shake and shingle panels. Illustrated fact sheets on fancy cut decorative shingles are also available.

Contact Ed Stanton, Vice President Sales, Shakertown Corporation, P.O. Box 400, Winlock, Wash. 98596.

Trus Joist Corporation

Brochure outlines product features, available joist and truss profiles, detail concepts and locations of local support offices.

Contact Peter H. Kowalchuck, Trust Joist Corporation, P.O. Box 60, Boise, Idaho 83707.

Western Wood Products Association

Reference book describes production, grading and uses of Western board lumber. \$2.

Contact Western Wood Products Association, Department 11, Yeon Building, Portland, Ore. 97204.

UCI 6: Wood and Plastics

American Enka Co.

Offers literature on Enkadrain foundation drainage for basements and retaining walls, Enkamat soil reinforcement matting and interior floor insulation.

Contact Enkamat Products Division, America Enka Co., Enka, N.C. 28728.

Architectural Aluminum Manufacturers Association

Offers guide for optimizing energy efficient design with manufactured dome skylight units.

Contact the Architectural Aluminum Manufacturers Association, 35 E. Wacker Drive, Chicago, Ill. 60601.

Atlantic Building Systems, Inc.

Brochure describes AR-6000 standing seam roof system, which is designed to float with the expansion and contraction caused by temperature fluctuations.

Contact Atlantic Building Systems, Inc., P.O. Box 82000, Atlanta, Ga. 30366.

continued on page 148

AT&T WAS CONCERNED WITH SERIOUS LEAKS AT HEADQUARTERS SO THEY PUT ENKADRAIN UNDERGROUND.



When AT&T began excavations for their new headquarters in New York City, they found themselves facing a wall of solid rock and a unique drainage problem. Water seeping from the rock made it necessary to put a drainage system between the rock and the foundation, but to maintain maximum area in the basement they needed to pour concrete against the rock wall.

For this unique problem, the builders chose a unique solution. Enkadrain® matting. Its flexibility and ability to conform to the irregularities in the rock wall while still functioning perfectly as a drainage medium made it the best possible choice.

Enkadrain is a composite of compression-resistant, 3-dimensional nylon matting and a polyester non-woven filter fabric. It is an ideal and economical solution for a whole range of drainage situations, whether in commercial and industrial buildings, underground homes or even conventional homes.

Enkadrain successfully replaces graded aggregate or gravel, for vertical drainage against underground walls. While gravel may in time clog and fail, Enkadrain resists clogging. And with Enkadrain you won't need protective boards or polyethylene film to protect waterproofing membranes. Enkadrain relieves hydrostatic pressure in wet clay and silt soils adjacent to underground basement walls and retaining walls and minimizes the problem of wet underground interiors and structural wall damage.

For more information, contact our nationwide distributor, American Excelsior, 850 Avenue H East, Arlington, TX 76011 (817) 640-1555.

Or consult Sweet's Catalog's General Building and Light Residential Construction sections (7.17/Am), or call toll-free Buyline (800) 447-1981.

ENKADRAIN® MATTING BY ENKA

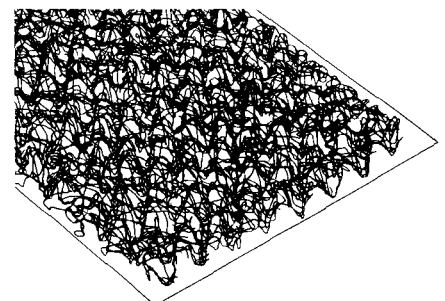

*Helps keep any building
on a solid foundation.*

Circle 60 on information card

UCI from page 146

Butler Manufacturing Co.

Offers information on CMR-24 standing-seam metal roof system.

Contact Butler Manufacturing Co., Buildings Division, BMA Tower, Kansas City, Mo. 64141.

Copper Development Association, Inc.

Offers 16mm film, "Copper in the Sun" that shows on-site construction of roll-formed copper roof systems and installation of active and passive solar collector systems on a Colorado residence.

Contact Copper Development Association, Inc., 405 Lexington Ave., New York, N.Y. 10174.

Diamond Shamrock Corporation

Offers information on Dacotherm, a silicate loose-fill insulation.

Contact Diamond Shamrock Corporation, Industrial Chemicals Unit, 351 Phelps Court, P.O. Box 2300, Irving, Tex. 75061.

Dryvit System, Inc.

Brochure describes application methods, thermal shock reduction capabilities, new and retrofit construction modes and design possibilities of the firm's "outsulation" system. In addition, an audiovisual presentation is available that shows a variety of completed projects.

Contact George Marshall, Dryvit System, Inc., One Energy Way, West Warwick, R.I. 02893.

Foilpleat Insulation, Inc.

Brochure describes the firm's insulation systems.

Contact Foilpleat Insulation, Inc., 2020 W. 139th St., Gardena, Calif. 90249.

GAF Corporation

Literature on GAF asphalt shingles illustrates typical roofs in a variety of colors and styles.

Contact GAF Corporation, Building Materials, 140 W. 51st St., New York, N.Y. 10020.

Howmet Aluminum Corporation

Offers information on the HP-400 Thermal Slot ribbon window system, a single-piece, slotted web window system.

Contact Howmet Aluminum Corporation, Architectural Products Division, P.O. Box 629, Terrell, Tex. 75160.

Keene Corporation

See p. 145 (UCI 3).

Koppers Co., Inc.

Offers brochure on roofing and waterproofing systems for industrial buildings with recommended specifications and procedures.

Contact Koppers Co., Inc., Organic Materials Group, 1900 Koppers Building, Pittsburgh, Pa. 15219.

Sanspray Corporation

Brochure covers basic product data on Sanspray's natural stone panel system.

Contact Lois Peckham, Sanspray Corporation, 630 Martin Ave., Santa Clara, Calif. 95050.

Tamms Industries Co.

Information is available on Speed Plug, a compound designed to stop water leakage in masonry.

Contact Tamms Industries Co., 1222 Ardmore Ave., Itasca, Ill. 60143.

Zero Weather Stripping Co.

32-page catalog of weatherstripping products includes detailed drawings and specifications of a number of sound-proofing and weatherproofing aids.

Contact Mr. Robert Leeds, Zero Weather Stripping Co., Inc., 415 Concord Ave., Bronx, N.Y. 10455.

UCI 8: Doors and Windows

Advanced Coating Technology, Inc.

Brochures outline product information, glazing, warranty and performance data of architectural reflective glass.

Contact Advanced Coating Technology, Inc., Rayflex Division, 306 Beasley Drive, Franklin, Tenn. 37064.

The Alumiline Corporation

Catalog describes entrance systems and curtain walls available.

Contact The Alumiline Corporation, Durnell Lane, Pawtucket, R.I. 02860.

Ampco Products, Inc.

Catalog offers specification details for High Pressure Decorative Laminate Doors and Aluminum Adjustable Frames.

Contact Ampco Products, Inc., 7795 W. 20th Ave., Hialeah, Fla. 33014.

Andersen Corporation

Offers a 92-page window replacement system selection guide, a three-ring binder file of details to scale, brochures describing the role of windows and doors in energy conservation and a complete product detail catalog.

Contact Jack M. Ullrich, Manager, Sales Promotion & Publicity, Andersen Corporation, Bayport, Minn. 55003.

Bilco Co.

Catalog describes complete line of steel and aluminum roof scuttles, fire vents, floor, pit and sidewalk doors. Technical data, details and specifications are included.

Contact Barbara S. Sivigny, Bilco Co., 37 Water St., West Haven, Conn. 06516.

Buchmin Industries Inc.

"Laminated Safety Glass-The Designer's Choice," a 30-minute film presented by Dupont/Laminated Safety Glass Association illustrates the use of the product in

architecture. An 18-page brochure is also available.

Contact Buchmin Industries Inc., 1485 E. Curtis, Reedly, Calif. 93654.

Customwood

Literature describes a variety of grille patterns, door designs and decorative hardware for residential and commercial applications.

Contact Terri Ratliff, Estimator, Customwood, Box 26208, Albuquerque, N.M. 87126.

Eliason Corporation

Offers price and specification catalog on Easy Swing Doors and other products.

Contact Sales Department, Eliason Corporation, P.O. Box 2128, Kalamazoo, Mich. 49003.

Hager Hinge Co.

Manual details types, applications, features and selection of hinges.

Contact Gerald T. Phelan, Hager Hinge Co., 139 Victor St., St. Louis, Mo. 63104.

Howmet Aluminum Corporation

Brochure describes the firm's line of products, such as replacement windows, facades and other structural components, designed for nonresidential exterior remodeling.

Contact Mike Edwards, Howmet Aluminum Corporation, Commercial Remodeling Division, 227 Town East Boulevard, P.O. Box 163, Mesquite, Tex. 75149.

LouverDrape, Inc.

Brochures describe features, application and installation of the L-D folding door. Also available are brochures describing Vertical Blind installations, giving full technical details and specifications on the various models of Vertical Blinds and explaining how Vertical Blinds with vinyl louvers are designed to conserve energy.

Contact Sandra B. White, LouverDrape, Inc., 1100 Colorado Ave., Santa Monica, Calif. 90401.

Marvin Windows

Offers a loose-leaf manual that contains section drawings, elevation tracing details and construction information on wood windows. Also described are casements, bay windows, gliders, awnings and patio doors.

Contact Marvin Windows, Warroad, Minn. 56763.

Reynolds Metals Co.

Offers two illustrated brochures that describe "SunSpace-Passive Solar Heating," a residential design concept with thermal-break sliding glass doors. Also available are two catalogs that outline windows and doors with details for insulating.

Contact Building Products Advertising, Reynolds Metals Co., P.O. Box 27003, Richmond, Va. 23261.

continued on page 150

Lone Star superstar.

The glass-sheathed Hyatt Regency Hotel and its companion Reunion Tower are fast becoming the landmarks of Dallas.

The 1,000-room hotel is completely curtained in LOF Vari-Tran® silver-coated glass windows and spandrels that mirror the 50-story tower and its Vari-Tran-glassed geodesic dome top.

Special features within the complex include the hotel's 18-story glass-roofed atrium and 6-story glass wall that give hotel guests spectacular views of Reunion Tower and its surrounding parks. And glass-enclosed elevators

that rise within the atrium, pop through the roof and ascend in a mirror glass shaft to the upper floors.

Equally impressive, this glass is energy efficient as well as beautiful. The Vari-Tran glass helps control heat gain and glare while it admits plenty of natural daylight. So air conditioning and artificial lighting expenses can be reduced. Combined with the matching Vari-Tran spandrels, it increases the buildings' visual impact, eliminates corrosion worries, improves employee morale, boosts civic pride and delights hotel guests.

If you'd like to learn how glass can help improve your performance and cut clients' energy bills, send \$1.00 for our definitive 43-page study "Predicting Daylight as Interior Illumination." Libbey-Owens-Ford Company, 811 Madison Ave., Toledo, Ohio 43695.

Circle 61 on information card

LOF Glass

A Libbey-Owens-Ford Company

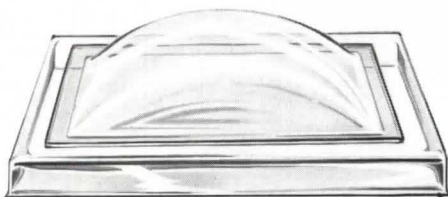

How to let light in without letting heat out.

Skylights formed from **UVEX® Plastic Sheet** can reduce costs by reducing the need for artificial lighting during daylight hours.

While the optical transparency of UVEX Sheet lets light in, its low thermal conductivity keeps heating and cooling losses low.

UVEX Sheet has excellent impact strength and outstanding resistance to weathering. And in many instances, skylights formed from UVEX Sheet can be flashed directly into the roof—eliminating the need for aluminum curbing or support.

For information and the name of the skylight manufacturer nearest you, contact Bill Seaman at Eastman Chemical Products, Inc., Plastics Products Division, Kingsport, Tennessee 37662.



Eastman Chemical Products, Inc., a subsidiary of Eastman Kodak Company, Kingsport, Tennessee. UVEX is Eastman's trademark for its plastic sheet. Eastman makes only the plastic sheet used in finished products and therefore makes no warranties with respect to such products.

UVEX®

Plastic Sheet

Circle 62 on information card

UCI from page 148

Rixson-Firemark, Inc.

Engineers will provide layout drawings for problem installations, unusual configurations in the design of pivots or door stops and custom orders for modified surface closers. Literature describes exterior and interior floor closers, overhead concealed closers, pivot sets and smoke-actuated door control devices.

Contact *Rixson-Firemark, Inc., 9100 W. Belmont Ave., Franklin Park, Ill. 60131.*
Schlage Lock Co.

28-page catalog details finishes, designs, functions and applications, plus standard and optional features of each series of locks.

Contact *Rich Jones, Schlage Lock Co., P.O. Box 3324, San Francisco, Calif. 94119.*

Sierracin/TransTech

Offers a number of brochures, films and demonstrations. Catalog explains security glazing. Films describe production and illustrate actual break-out tests. Demonstrations using bullet resistant glass will be provided throughout the U.S. and Canada.

Contact *Marketing Customer Service, Sierracin/TransTech, 12780 San Fernando Road, Sylmar, Calif. 91342.*

Thiokol

Brochures detail technical data and applications of insulating with glass. Also available is "Joint Design Digest," a guide to the use of polysulfide base sealants for expansion joints and glazing.

Contact *A. B. Katz, Thiokol Specialty Chemicals Division, 930 Lower Ferry Road, Trenton, N.J. 08650.*

Von Duprin Inc.

Catalog describes the complete line of touchbar and lever arm exit devices for both fire and panic applications.

Contact *Chuck Heckman, Sales Development Manager, Von Duprin Inc., 400 W. Maryland St., Indianapolis, Ind. 46225.*

Weather Shield Manufacturing, Inc.

Brochure describes SolaireFilm wood windows and doors and illustrates applications of the glazing system.

Contact *H.J. Koester, Weather Shield Manufacturing, Inc., P.O. Box 309, Medford, Wis. 54451.*

UCI 9: Finishes

American Olean Tile Co.

Brochure illustrates entire glazed, quarry and ceramic mosaic tile product lines. Shows pregrouted tile systems, bathroom accessories, allied setting materials, mural patterns and color coordination services.

Contact *American Olean Tile Co., 1000 Cannon Ave., Lansdale, Pa. 19446.*

Armstrong World Industries

Offers literature on commercial ceiling tiles, acoustical wall panels and resilient flooring products. A reference source of product information sheets, installation and maintenance publications, test results and architectural specifications on commercial products are also available. Contact *Armstrong World Industries, Inc., P.O. Box 3001, Lancaster, Pa. 17604.*

Badische Corporation

Offers a series of 21 publications describing the firm's line of line of carpets. Four recently added brochures are: "Contract Carpet Selection and Specification Guide," "Guidelines for Maintenance and Cleaning of Commercial Carpet," "Zedran Acrylics in Contract Carpet Fill the Luxury Gap," "What Every Contract Carpet Specifier Should Know about Nylon." Carpet consultant service will provide samples, conduct specialized seminars and assist in writing specifications. Contact *the Create Center, Badische Corporation, Williamsburg, Va. 23185.*

Columbus Coated Fabrics

12-page color brochure reviews the three types of vinyl wallcoverings and their properties. Included are suggestions on installation, application, maintenance, cleaning and other information. Contact *Columbus Coated Fabrics, Box 307, Columbus, Ohio 43216.*

Conwed Corporation

Brochure outlines acoustical products, including ceiling panels and tiles, wall panel systems and freestanding screens. Also available are condensed pamphlets on individual products.

Contact *Sheila A. Katusky, Advertising Department, Conwed Corporation, P.O. Box 43237, St. Paul, Minn. 55164.*

The Diller Corporation

Offers literature on several lines of high pressure laminate wall panels. Finishes include aluminum, copper, mirror chrome, oak, mahogany and cane weave fabric. Contact *Marvin A. Cohen, National Sales Manager, The Diller Corporation, P.O. Box C, Morton Grove, Ill. 60053.*

Flexi-Wall Systems

Offers passive solar energy fact sheets and test data on smoke toxicity, bond strength and impact resistance on adhesives and protective coating. Also available are swatch cards showing the French and Scotland weave patterns. Contact *Flexi-Wall Systems, P.O. Box 88, Liberty, S.C. 29657.*

Focal Point Inc.

Brochure describes and illustrates the

continued on page 152

P L A N A R



Job Site: Detroit Medical Center

Alcan Planar® Ceiling Systems: combines dramatic visual effect with functional, highly flexible installation.

Finish: Silicon polyester over aluminum panel. Weather resistance and structural strength for interior or exterior applications.

Colors: A spectrum of five tasteful low-gloss shades of blue.

Ventilation/Lighting: Easily accomplished through incremental slots between panels, without cutting or modification of the ceiling.

Architect: William Kessler and Associates, Incorporated, Detroit, Michigan; Zeidler Partnership, Incorporated, Toronto, Ontario; Giffels Associates, Incorporated, Southfield, Michigan. Associated architects, engineers and planners.

Availability: Exclusively through Alcan Building Products.

Information: Write "Planar," Alcan Building Products, P.O. Box 511, Warren, Ohio 44482.

Alcan Building Products

Division of Alcan Aluminum Corporation



Circle 63 on information card

UCI from page 150

firm's cornice moldings, domes, ceiling medallions, mantels, niche capes, over-door pieces, spandrels, stair brackets, along with ordering information.

Contact Irene K. Moore, Focal Point Inc., 2005 Marietta Road N.W., Atlanta, Ga. 30318.

Forms + Surfaces

Offers information on ceiling systems, bonded bronze wall panels and unglazed pavers and glazed ceramic tiles.

Contact Jan Winter, Director of Communications, Forms + Surfaces, Box 5215, Santa Barbara, Calif. 93108.

GAF Corporation

Offers information on GAFSTAR No-Wax Decorator tiles.

Contact Sylvia K. Lowe, GAF Corporation, 140 W. 51st St., New York, N.Y. 10020.

Glidden Coatings & Resins

Offers a number of audiovisual presentations and publications. Brochures explain several protective maintenance coatings and applications in a variety of industrial settings. Presentations include, "Coatings for Petroleum Plants," "Application and Inspection of Coatings," "Planned Painting Program."

Contact Bernice Bolek, Glidden Coatings & Resins, Division of SCM, 900 Union Commerce Building, Cleveland, Ohio 44115.

Kentucky Wood Floors

Brochure presents the complete product line, from custom classics and end grain floors to basic plank and parquet. Installation and maintenance accessories are outlined.

Contact Kentucky Wood Floors, 7761 National Turnpike, Louisville, Ky. 40214.

Masonite Corporation

Literature describes the firm's commercial line of plank and panel systems, such as Korelock, Monoplank, Displawall and Firetest. Information is also available on adhesives and reinforced paneling.

Contact Sandra E. Nipple, Marketing Services Administrator, Masonite Corporation, Commercial Division, Dover, Ohio 44622.

MFG Inc.

Represents a number of Italian ceramic tile manufacturers. Color brochures are available on complete product lines.

Contact L. D. Kladder, MFG Inc., P.O. Box 370547, Miami, Fla. 33137.

Nevamar Corporation

Brochure describes Nevamar ARP surface, which is designed to provide greater abrasion resistance and longer life than standard laminates.

Contact Nevamar Corporation, 8339 Telegraph Road, Odenton, Md. 21113.

PPG Industries

Information is available on the firm's Super Design Accent Colors water-based interior coatings.

Contact Ann Cain, Public Relations Department, PPG Industries, Inc., One Gateway Center, Pittsburgh, Pa. 15222.

Robertex Associates, Inc.

Brochures describe the libretto and sonata collections of wool carpets.

Contact Robertex Associates, Inc., 576 Armour Circle N.E., Atlanta, Ga. 30324.

Span Metals Corporation

Literature and samples illustrate the pre-finished roll-formed architectural panel and roofing panel system such as the original hat and channel framing design. Engineering and technical data are available on all products.

Contact John A. Eller, Advertising Manager, Span Metals Corporation, P.O. Box 26288, Dallas, Tex. 75226.

U.S. Gypsum Co.

Information is available on the Omni Fissured pattern of Auratone acoustical ceiling panels and tiles.

Contact Alvina Ewing, Public Relations Department, U.S. Gypsum Co., 101 S. Wacker Drive, Chicago, Ill. 60606.

continued on page 154

How paying more for a roof insulation can cost you less!

There's more to roof insulation than an R Value and price! The physical properties can add or subtract from the performance and longevity of the roof system itself.

When the roof deck averages only 2% of the total cost of a building yet is responsible for more architectural firm law suits than any other portion of the building, isn't it prudent to consider a roof system with a proven track record of successful performance? Regardless of the membrane brand used, systems utilizing All-weather Crete insulation have such a record. AWC costs slightly more than other insulations. This is due to its unique properties and installation.

In addition to supplying superb insulation, it aids in retarding roof deterioration and leakage. There are fewer or no leak repairs or re-roofs. Roofs generally last years longer and pay for themselves over and over - therefore, actually cost less.

Ask the satisfied building owner who has an AWC insulated roof . . . or write for a free booklet with the facts!



6300 River Road
Hodgkins, Illinois 60525
(312) 735 - 3322

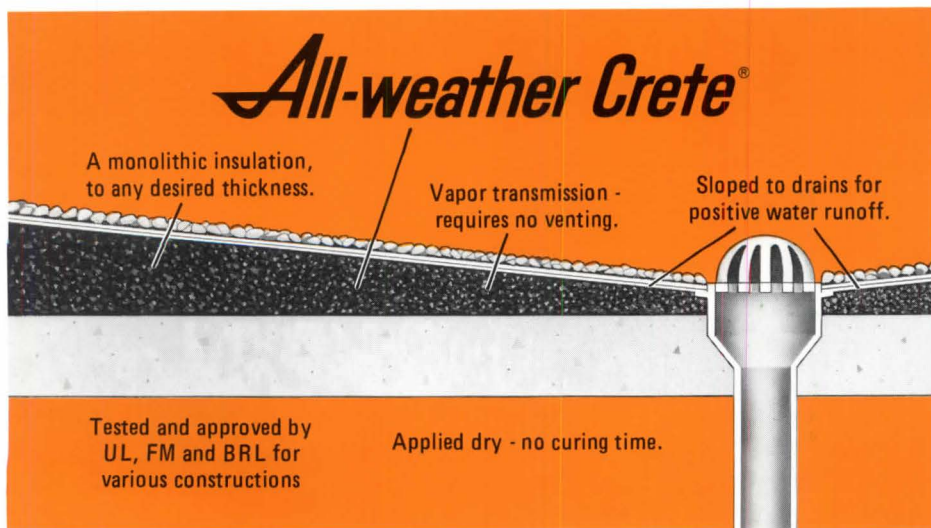

... IN SIZE

COLOR

TEXTURE

TRADITION

*Belden
Brick Measures
Up....*

TRADI-
TION

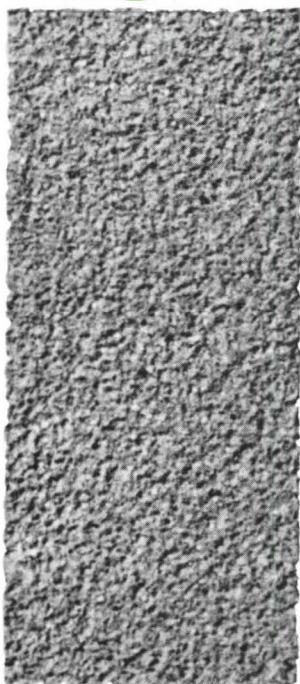

Since 1885, BELDEN has been in the business of manufacturing brick. It has been a labor of love, steeped in a tradition of quality. Today, BELDEN provides the architect with more colors, more sizes, and more textures. A selection of over 200 variations for virtually unlimited choice. That's why so many creative architects call on BELDEN.

Your BELDEN Dealer will show you the facts in the form of samples, or write us direct for a catalog to Box 910, Canton, Ohio 44701.



Circle 65 on information card

1885-1981

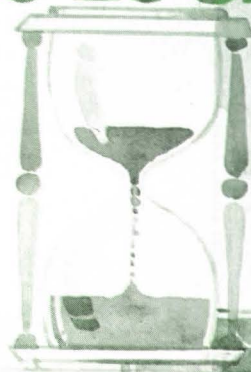

UCI from page 152

Vicrtex Le Carpenter & Co.

Offers a guide for writing specifications for vinyl wallcoverings and a catalog of various patterns of Vicrtex, Vicrmode and Natural Classics wallcoverings. Also available is a film presentation by a Vicrtex representative.

Contact K. W. Hanlon, Vicrtex Le Carpenter & Co., Warton, N.J. 07885.

Wilsonart

Three wall panel systems are described in a six-page brochure. Tech-data sheets provide detailed information on proper specification and installation methods. Also illustrated is the collection of 108 woodgrain, leather, slate and marble decorative laminates.

Contact Wilsonart, 600 General Bruce Drive, Temple, Tex 76501.

UCI 10: Specialties

AllianceWall Corporation

Brochures describe porcelain enamel panels and offer selection charts, specifications and U and R factors. Also available is information about Chalkboard and Whyteboard writing surfaces.

Contact Jerry Foster, Executive Vice President, AllianceWall Corporation, P.O. Box 48545, Atlanta, Ga. 30362.

American Canvas Institute

16-page brochure offers concepts for commercial application of canvas. It describes types, uses and treatments of canvas fabric.

Contact William F. Jordan, Executive Director, American Canvas Institute, 10 Beech St., Berea, Ohio 44107.

Bethlehem Steel Corporation

Offered on a loan basis is a video/slide presentation on the design of health care facilities and the advantages of interstitial space—the enlargement of the depth between the ceiling and the floor above providing a walk-through area for maintenance.

Contact Sales Engineering, Room 253, GSO, Bethlehem Steel Corp., Bethlehem, Pa. 18016

Eljer Plumbingware

Brochure features six new bathroom designs and offers floor plans, a list of materials used in each bathroom, plus tips on bathroom planning and product selection.

Contact Eljer Plumbingware, Wallace Murray Corporation, Three Gateway Center, Pittsburgh, Pa. 15222.

E.F. Hauserman Co.

Offers material on its privacy panel system, which provides differentiated privacy with four panel heights.

Contact Tom Noble, Manager, Marketing Communications, E.F. Hauserman Co., 5711 Grant Ave., Cleveland, Ohio 44105.

Heidapal

Eight-page fold-out brochure shows the various kitchen and bath styles available. It is supplemented with an 1981 update of the newest styles.

Contact Lynn Schroeder, Administrative Assistant, Heidapal Designs, Inc., 719 Swift St., #1, Santa Cruz, Calif. 95060.

I.D. Graphics Inc.

Brochure details the firm's line of directory signage.

Contact Ted Cooper, I.D. Graphics Inc., 821 Airport Way S., Seattle, Wash. 98134.

INTEST Laboratories, Inc.

Literature explains the firm's consulting, testing and monitoring services. Material also describes the company's acoustical analysis laboratory that evaluates open-plan offices, ceiling acoustics and electronic sound masking.

Contact Donald J. Valsvik, President,

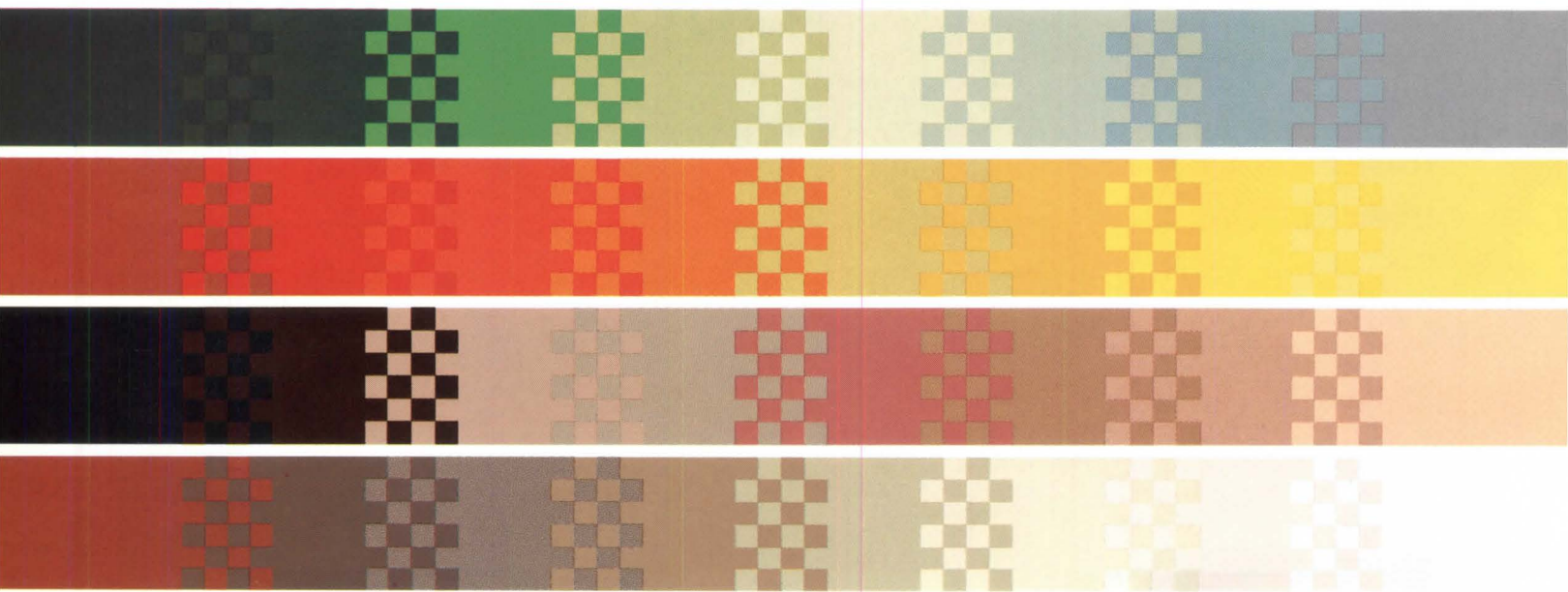

The colors you want.

Wilsonart's freshly edited and greatly expanded solid color collection includes 64 precise colors for professional designers.



To see all 64 solid colors and for an unusual creative experience, visit and enjoy the Wilsonart Moongate Exhibit when it is in your city.

INTEST Laboratories, Inc., 2820 Anthony Lane S., Minneapolis, Minn. 55418.

Jacuzzi Whirlpool Bath

Catalogs feature entire line of whirlpool baths and whirlpool spas.

Contact Advertising Department, Jacuzzi Whirlpool Bath, P.O. Drawer J, Walnut Creek, Calif. 94596.

JG Wilson Corporation

Brochures describe rolling doors, grilles, horizontal doors and storage systems.

Contact J.L. Bevan, Executive Vice President, JG Wilson Corporation, P.O. Box 599, Norfolk, Va. 23501.

Kohler Co.

Offers 215-page catalog of plumbing and leisure products for residential, commercial and institutional installations that features pictures, descriptions and specifications for whirlpool baths, spas, bathtubs, toilets and drinking fountains. A booklet to assist with color coordination and decorating is also available.

Contact Lewis Hildebrand, Supervisor, Production and Procurement, Advertising and Promotional Services, Kohler Co., Kohler, Wis. 53044.

Kwik-Wall Co.

Offers information on portable and operable wall systems.

Contact Verlin Robbins, Kwik-Wall Co., P.O. Box 3267, Springfield, Ill. 62708.

LCN Closers

Brochure provides information on codes and regulations applicable to designing entrances for the handicapped. Door closers for barrier-free access are described in detail, including Equalizer, Delayed Action Smoothee and 4041 Super Smoothee. *Contact LCN Closers, Division of Schlage Lock Co., P.O. Box 100, Princeton, Ill. 61356.*

LouverDrape

See p. 148 (UCI 8).

Lunstead Designs

Information describes the Matrixsystem, open office system incorporating a computer module.

Contact Harry Lunstead Designs, Inc., John Kennell, Marketing Manager, 8655 S. 208th St., Kent, Wash. 98031.

Masonite Corporation

Literature available on firm's product line of Planks and Panels, Displawalls, Fire-test panel, adhesives, doors, toilet compartments, modular buildings, partitions. *Contact Sandra E. Nipple, Marketing Services Administrator, Masonite Corporation, Commercial Division, Dover, Ohio 44622.*

Miami-Carey

Offers information on 13 new bathroom vanities.

Contact Robert Armstrong, Advertising, Miami-Carey, 203 Garver Road, Monroe, Ohio 45050.

Rally Racks

Brochure details installation, applications and design of the firm's bicycle and moped parking system.

Contact Rally Racks, 20450 Broadway, Drawer 299, Sonoma, Calif. 95476.

Scott Plastics Co.

Offers information on its 46 styles of dimensional plastic and foam letters and logos.

Contact David B. Gibson, Scott Plastics Co., P.O. Box 2958, Sarasota, Fla. 33578.

Spacesaver Corporation

Planning guide assists in designing modular mobile carriage systems for efficient storage and filing.

Contact Ron Staller, Spacesaver Corporation, 1450 Janesville Ave., Fort Atkinson, Wis. 53538.

Steelcase

Information is available on EIP open office components—free-standing printer units with slotted worksurfaces, split-top
continued on page 156



The service your fabricators need.

Colors for you. Service for your fabricators. Wilsonart solves both these critical needs. Ask your Wilsonart rep to show

you the 1981 Wilsonart solid colors. Or write: Wilsonart, 600 General Bruce Dr., Temple, Texas 76501 for brochures.

WILSONART
WILSONART BRAND DECORATIVE LAMINATE
Copyright© 1981, Ralph Wilson Plastics Company
600 General Bruce Drive, Temple, Texas 76501

UCI from page 155
machine tables, pullout keyboard shelf, corner worksurfaces, cableways and carousel unit. It's designed for use with the Series 9000 Systems Furniture.
Contact Steelcase, 1120 36th St. S.E., Grand Rapids, Mich. 49501.

Tri-Guards, Inc.

Information available on Lexan corner Guard and Lexan wall Guard or chair rail.

Contact George Triunfol, President, Tri-Guards, Inc., 953 Seton Court, Wheeling, Ill. 60090.

Western Electric

Color brochure and technical information describes public telephone facilities.
Contact Lauren Beane, Western Electric, 50 Lawrence Road, Springfield, N.J. 07081.

UCI 11: Equipment

McGuire Co.

Film features the Autodok System, an automated loading dock system.
Contact George Atwell, McGuire Co., Hudson, N.Y. 12534.

National Sanitation Foundation

Pamphlets describe NSF's publications, regional seminars and catalogs.
Contact Tom S. Gable, Senior Vice President, National Sanitation Foundation, 3475 Plymouth Road, P.O. Box 1468, Ann Arbor, Mich. 48106.

UCI 12: Furnishings

Atelier International, Ltd.

Price specifications guide describes the firm's designer furnishing collection and its rapid-delivery programs and includes a copy of the sales agreement. Also available is a catalog describing the Marcatré Office Furniture System.

Contact Atelier International, Ltd., 595 Madison Ave., New York, N.Y. 10022.

Atlanta Architectural Textiles, Inc.

Catalog illustrates the firm's line of upholstery, wallcovering and panel fabrics.
Contact Atlanta Architectural Textiles, Inc., P.O. Drawer 1, 351 Peachtree Hills Ave., Atlanta, Ga. 30305.

Charrette

See p. 144 (UCI 1).

Conwed Corporation

Brochures give complete specifications on

the company's full line of freestanding acoustical panels, wood desks, open-office furniture systems and other commercial interior products. Swatch cards and color samples are available, in addition to two brochures defining the role of acoustics in the open-plan office.

Contact Sheila A. Katusky, Advertising Department, Conwed Corporation, P.O. Box 43237, St. Paul, Minn. 55164.

Kimball Office Furniture Co.

Offers information on the new line of Focus Lounge furniture, as well as the entire line of Kimball products.

Contact Kimball Office Furniture Co., A Division of Kimball International, Inc., 1549 Royal St., Jasper, Ind. 47546.

Knoll International

Catalog lists all fabrics currently offered, with specifications and prices.

Contact Knoll International, Knoll Textiles Operations Center, P.O. Box 157, East Greenville, Pa. 18041.

Lundia, Myers Industries, Inc.

Offers literature, consultation, layouts, pricing and multimedia presentations of Fullspace mobile high-density filing and storage systems and literature and a slide presentation on store fixtures.

Contact Lundia, Myers Industries, Inc.,

Task ambient lighting From the pioneers

Light up, down or from the side precisely and efficiently with equipment for any requirement and for use with any furniture or partition system. Designed by Sylvan R. Shemitz.

elliptipar[®] inc.

Robert Edwards
Vice president engineering
145 Orange Avenue
West Haven, CT 06516
203-932-2266



pool lift

makes swimming barrier free

- Simple to install in above and below ground pools
- Low cost installation
- Easy and safe to operate - No electricity or hydraulics
- Suitable for new or existing pools
- Rugged, corrosion resistant construction

Send today for details to:

 6315 Shawson Drive, Unit #4
Mississauga, Ontario
L5T 1J2
Telephone: (416) 678 2590
Telex: 06-983513

500 Capitol Way, Jacksonville, Ill. 62650.

Metropolitan Furniture Corporation

Offers product brochures on its collection of residential and contract designs. Also available are two 35mm slide presentations: one on design, form and function; the other on the Series 10 Seating System—its basic design and installation, service and maintenance procedures. A Metro Furniture catalog is available for \$25.

Contact *Alycia Umemoto, Manager, Marketing Services, 950 Linden Ave., South San Francisco, Calif. 94080.*

Owens-Corning Fiberglas Corporation

Brochure lists state fire codes for hospital draperies and cubicle curtains and discusses the firm's Beta-Care, a glass fiber, fire-resistant fabric.

Contact *Owens-Corning Fiberglas Corporation, Decorative Fabrics Division, 717 Fifth Ave., New York, N.Y. 10022.*

R-Way Furniture Co.

Catalogs describe stock and custom designed conference tables, bank check writing tables and desks. Also available is information on the firm's standard contract groupings.

Contact *Don Schackmuth, R-Way Furniture Co., 740 Commerce St., Sheboygan, Wis. 53081.*

Thonet

Audiovisual presentation outlines the company's 150-year history. Also available is a Thonet history poster and a brochure featuring the stackable Sof-Tech chair designed by David Rowland.

Contact *Peggy McFadden, Marketing Assistant, Thonet, P.O. Box 1587, York, Pa. 17405.*

Vecta Contract

Offers color brochures describing the product lines and including the 1981 introductions of Wilkhahn's seating lines and Binar stacking chair. Templates for laying out Tappo and Miko seating systems are also available.

Contact *Communications Manager, Vecta Contract, 1800 S. Great Southwest Parkway, Grand Prairie, Tex. 75051.*

UCI 13: Special Construction

Armstrong World Industries, Inc.

Brochure describes the firm's architectural ceiling and lighting systems, such as C-60/60, Luminaire, Synercon 60, Symmetry Luminaire, Quadralon, Trimlok and Parabolok Lighting System. Information is also available on lighting measurement, air handling systems and fire ratings.

Contact *Armstrong World Industries, Inc., P.O. Box 3001, Lancaster, Pa. 17604.*

Birdair Structures

16-page brochure outlines history, technology, current and future applicants of permanent fabric architecture; describes uses and advantages of both air-supported and tensioned-structure varieties of permanent fabric architecture; outlines benefits to be obtained from using the firm's vertically integrated design/build capabilities and describes thermal/optical properties of the complete variety of available architectural fabrics and energy advantages. A 12-minute narrated slide show presents the variety of forms possible with permanent fabric architecture. And the advantages of the firm's design/

build capacity as it can apply to permanent fabric architecture can be presented by a representative of the firm.

Contact *Lora E. Spiller, Communications Manager, Birdair Structures, Division of CHEMFAB, P.O. Box 476, North Bennington, Vt. 05257.*

Recreonics Corporation

Buyer's guide and operations handbook describes the firm's line of swimming pools, aquatics and recreational equipment.

Contact *Julie Taraba, Recreonics Corporation, 1635 Expo Lane, Indianapolis, Ind. 46224.* continued on page 158

MEDUSA

for Creative Concrete Construction



Whatever your concrete construction requirement—Medusa makes the cement to fill your creative need.

MEDUSA WHITE PORTLAND CEMENT—lends itself to unlimited architectural creativity in color, form and texture. Write for colorful, informative brochure.

MEDUSA CUSTOM COLOR MASONRY CEMENTS—provide the modern building team with a wide assortment pre-mixed masonry cement colors. Colors that will enhance the aesthetic beauty of modern masonry—as well as its acceptance.



Call Sweet's Buy-Line 800-447-1980
or—the Medusa number below.

MEDUSA CEMENT COMPANY
P.O. Box 5668 Cleveland, Ohio 44101 (216) 371-4000.

UCI from page 157

UCI 14: Conveying Systems

Armor Elevator Co.

Literature outlines the company's elevator maintenance program, elements of Dyn-glide (the solid state drive system) and the energy efficient elevator call button that can be hand activated.

Contact R. Scott Gill, Manager, Marketing Services, Armor Elevator Co., 5534 National Turnpike, Louisville, Ky. 40214.

Bethlehem Steel Corporation

Offers on a loan basis the slide presentation, "Going Up," a brief history of elevator rope, manufacturing methods, product applications and specifications.

Contact Sales Engineering, Room 253, GSO, Bethlehem Steel Corporation, Bethlehem, Pa. 18016.

Otis Elevator Co.

Report provides a brief history of the elevator, an explanation of how it works, safety features, maintenance techniques and safeguards. Information on elevator

control systems and computer technology is also available.

Contact Otis Elevator Co., Department 520, One Farm Springs, Farmington, Conn. 06032.

UCI 15: Mechanical

Chicago Faucet Co.

Catalog contains more than 80 product photos with descriptive information covering the full line of residential, commercial, institutional, laboratory and food service faucets.

Contact Chicago Faucet Co., 2100 S. Nuclear Drive, Des Plaines, Ill. 60018.

Clearline Inc.

Specification sheet describes Teleflex system, a mechanical window operator control system.

Contact Clearline Inc., P.O. Box 1368, North Wales, Pa. 19454.

Copper Development Association, Inc.

Offers two design handbooks, "Copper Solvent Single-Stack Plumbing System" and "Engineered Copper Fire Sprinkler Systems." Technical data, installation and design information are included.

Contact Copper Development, 405 Lexington Ave., New York, N.Y. 10016.

Ebco Manufacturing Co.

Offers information on semi-recessed and wall-mounted Oasis water coolers.

Contact Ebco Manufacturing Co., 265 N. Hamilton Road, Columbus, Ohio 43213.

Eljer Plumbingware

See p. 154 (UCI 10).

Glidden Coatings & Resins

See p. 152 (UCI 9).

Grinnell Fire Protection Systems Co., Inc.

Brochure illustrates various examples of architecture that utilize sprinkler systems without intruding on design esthetics.

Contact Advertising Department, Grinnell Fire Protection Systems Co., Inc., 10 Dorrance St., Providence, R.I. 02903.

Grunau Co.

Technical mini-catalog describes automatic sprinklers, valves, accessories and related products for fire protection systems.

Contact Advertising Department, Grunau Sprinkler Manufacturing, Box 220, South Milwaukee, Wis. 53172.

Guard-Nut, Inc.

Brochure describes fastener products in-

continued on page 160

PURE VICTORIAN.

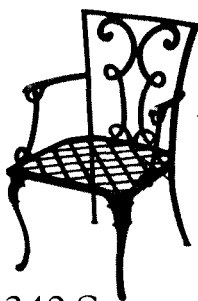

Welsbach,
240 Sargent Drive, New
Haven, CT 06511.

Welsbach offers a cornucopia of original design in exquisitely crafted metal furniture and authentic lighting. All pure Victorian.

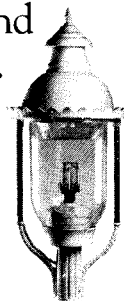
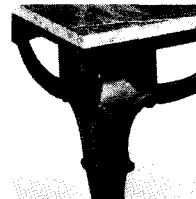

Outdoors Welsbach stands unique. Indoors Welsbach forms environments.

ELK PRESTIQUE
SHINGLES LOOK ENUFF
LIKE WOOD TO FOOL
AN EXPERT...ME!



If that was the *only* reason to carry Elk Prestique laminated fiberglass shingles, you'd *still* do a super business! But Prestique has the look of wood . . . without the *fire hazard*! The U.L. gives it their Class "A" rating; that's their highest! Know what else? Elk Prestique has a 30 year limited warranty . . . the longest in the business! Its 2-ply construction delivers twice the protection of conventional 3-tab single-ply asphalt shingles! So, if anybody suggests getting cheaper asphalt shingles, set 'em straight! Tell 'em Prestique delivers a lot more for their money! More protection! More warranty! And more value added onto their homes—specially when they get around to selling it! Elk Prestique is tops! Ask me! I know!

Ennis, Texas, 214-875-9611 • Stephens, Arkansas, 501-786-5484 • Tuscaloosa, Alabama, 205-758-2752 • Tempe, Arizona, 602-831-7399



AN ELKOR COMPANY

PRESTIQUE SHINGLES

Circle 72 on information card

UCI from page 158

cluding Tamper-Proof System, Torque Limiter and a Shear Type fastener.

Contact *Guard-Nut, Inc., P.O. Drawer 299, Sonoma, Calif. 95476.*

Halsey Taylor

Offers literature on water coolers and drinking fountains including information on the barrier-free units that meet ANSI standards. Dimensional drawings and mechanical specifications are available.

Contact *Mr. Chris Kroos, V.P. Marketing, Halsey Taylor, Division of King-Seeley Thermos Co., Route 75, Freeport, Ill. 61032.*

Honeywell Inc.

Offers information on the two-function Power Line Carrier 720 system, which is designed to allow greater control and management of energy-using devices while cutting the cost of installation.

Contact *Sylvia M. Burgos Wander, Honeywell Inc., Honeywell Plaza, Minneapolis, Minn. 55048.*

Jade Controls, Inc.

Information is available on the Model H/P-CL programmable digital thermostat for heat pumps.

Contact *Jade Controls, Inc., P.O. Box 271, Montclair, Calif. 91763.*

Jewett Refrigerator Co., Inc.

Offers 142-page hard-cover, loose-leaf catalog that describes blood bank, pharmacy laboratory and hospital refrigerators and freezers. Specifications and instructions include metric dimensions.

Contact *Jewett Refrigerator Co., Inc., 2 Letchworth St., Buffalo, N.Y. 14213.*

Kee Klamp

24-page catalog outlines specifications and applications of more than 41 Kee Klamp fittings. A solar collector support system is also illustrated.

Contact *Frank O'Mara, General Manager, Kee Klamp, Division of Gasoigne Industries, P.O. Box 207, Buffalo, N.Y. 14240.*

Kim Lighting, Inc.

Catalog, "Architectural Fountain Components," provides technical information for water display systems including illustrations of nozzles, pumps, filtration systems and controls.

Contact *Doug Paulin, Assistant Sales Manager, Kim Lighting, Inc., 16555 E. Gale Ave., City of Industry, Calif. 91749.*

Kohler Co.

See p. 155 (UCI 10).

Koppers Co., Inc.

Brochure describes a variable volume air flow assembly designed to save energy.

Contact *Air Cleaning Systems Group, Environmental Elements Corporation, Koppers Co., Inc., 1221 International Parkway, Richardson, Tex. 75081.*

Microphor, Inc.

Literature describes complete line of flow-through, on-board marine sanitation devices. Technical information, applications and watersaving case histories about the Two-Quart toilet from Microphor is also available.

Contact *Michael Zizek, Marketing Service Manager, Microphor, P.O. Box 490, Willits, Calif. 95490.*

The Oregon Water Heater Co., Inc.

Pamphlet describes the company's new heat pump water heaters.

Contact *Jim McKillip, Oregon Water Heater Co., Inc., 8190 S.W. Nimbus, Building 5, Progress, Ore. 97005.*

Pipe Systems, Inc.

Information available on The Energy Rod, designed especially for use in passive solar structures and systems.

Contact *Pipe Systems, Inc., 1533 Fenpark Drive, Fenton, Mo. 63026.*

Rixson-Firemark, Inc.

See p. 150 (UCI 8).

continued on page 163

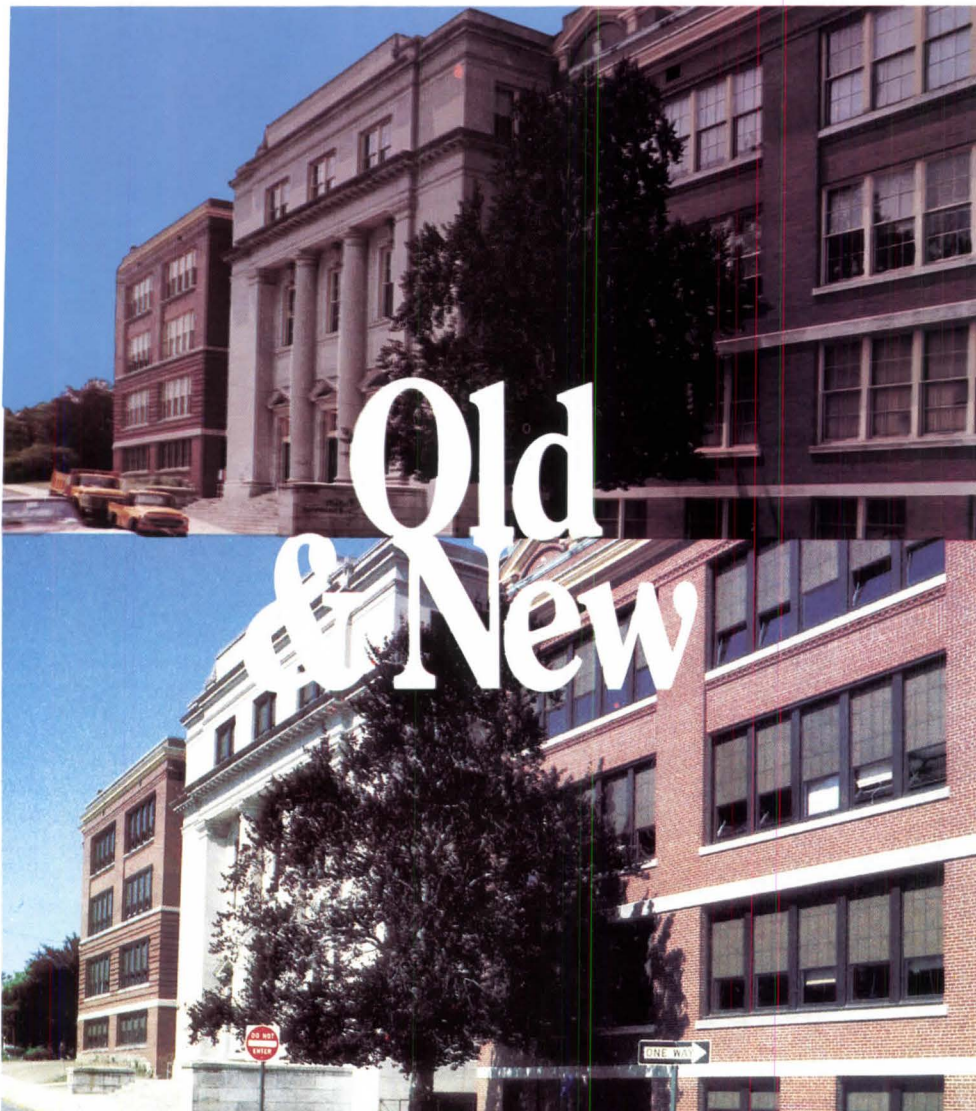

Window Retrofit Robinson Green Beretta Corporation, Architects

Kalwall

The most highly insulated light transmitting material.
Saving energy for 25 years.

KALWALL CORPORATION

1111 Candia Road, Manchester, NH 03103, 603-627-3861

See Sweet's 8.14/Ka, 7.8/KaL, 13.11a/Ka, 13.2c/Stu.

**BANG IT.
BUMP IT.
WHACK IT.
THUMP IT.**

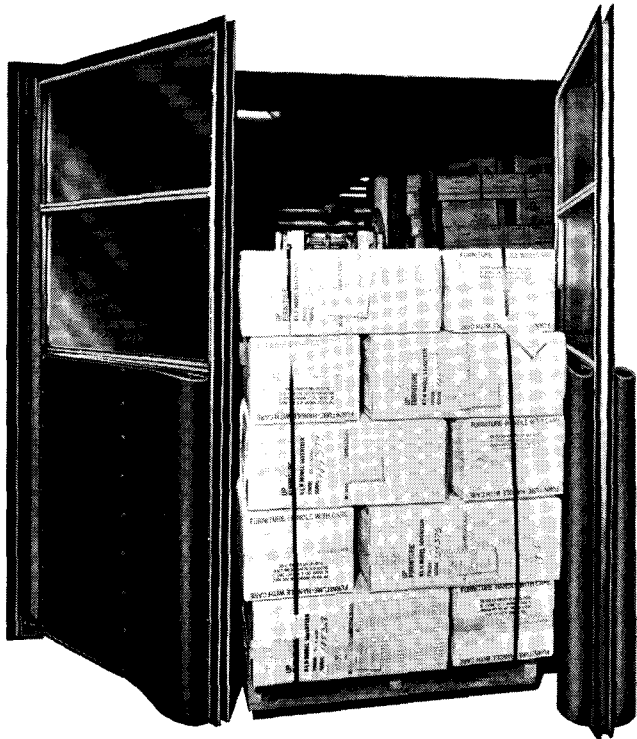

McGUIRE TRAFFIC DOORS STAND UP TO HARD KNOCKS AND COME BACK SWINGING.

Designed to conserve energy, McGuire's Fendor features welded tubular steel frame construction, large Lexan® vision areas, insulated panels, double gasketing, massive V-Cam gravity action hinges, thick wall hinge posts, and formed 1/2" thick rubber centerpointed bumpers.

For all your traffic door requirements, contact your McGuire rep or **The McGuire Co., Inc., 1 Hudson Avenue, Hudson, N.Y. 12534. (518) 828-7652, AUTODOK, Telex: 145-490 HUON**



Circle 73 on information card



This man can bring you what you need to know about metal framing.

He's sitting in your drawer, just waiting to bring you important information on Unistrut® Systems.

You'll learn how to solve complex problems such as dividing and multiplying space. We'll send you catalogues on support systems of all kinds.

But we can't do anything until you fill out this form, put it in an envelope and put that man to work.

To: Unistrut Systems, 35005 Mich. Avenue West, Wayne, MI 48184. Please send me what I need to know about: 20

- Industrial Support Systems
- Electrical Support Systems
- Mechanical Support Systems
- Medical Support Systems
- Moduspan Space Framing
- Exhibits and Displays

Name _____ Title _____

Company _____ Phone # _____

Address _____

City _____ State _____ Zip _____

UNISTRUT | **GTS**

The KAD II Koh-I-Noor Auto Draw is electronically controlled to produce rapidly a virtually limitless library of lettering styles, symbols and designs used in engineering, electronic and architectural drawings, as well as the drawings of many other disciplines. Once demonstrated, KAD II requires no special operating skills.

KAD II consists of three components. The PLOTTER, less than four pounds, adapts to almost every drafting machine. It draws with liquid ink in any one of five preprogrammed character heights on most drawing surfaces. Servo motors operate the pen holder to produce faster and better quality characters than can be



provided by any hand lettering device.

The CONTROLLER contains the logic circuitry to operate the Plotter. It drives the Plotter by commands from a standard or custom preprogrammed ELECTRONIC TEMPLATE MODULE (ETM) placed into a receptacle in the front panel. The Controller can be placed on the drawing board, on a roll-away stand, or any other handy location within cable length of the Plotter. ETM's are quickly interchangeable to provide different symbols or lettering styles as required. Each ETM has its own corresponding keyboard overlay indicating its preprogrammed functions. Send the coupon today.

KAD II Auto Draw

The most versatile, electronically controlled lettering and symbol-generating instrument available from today's microprocessor technology!

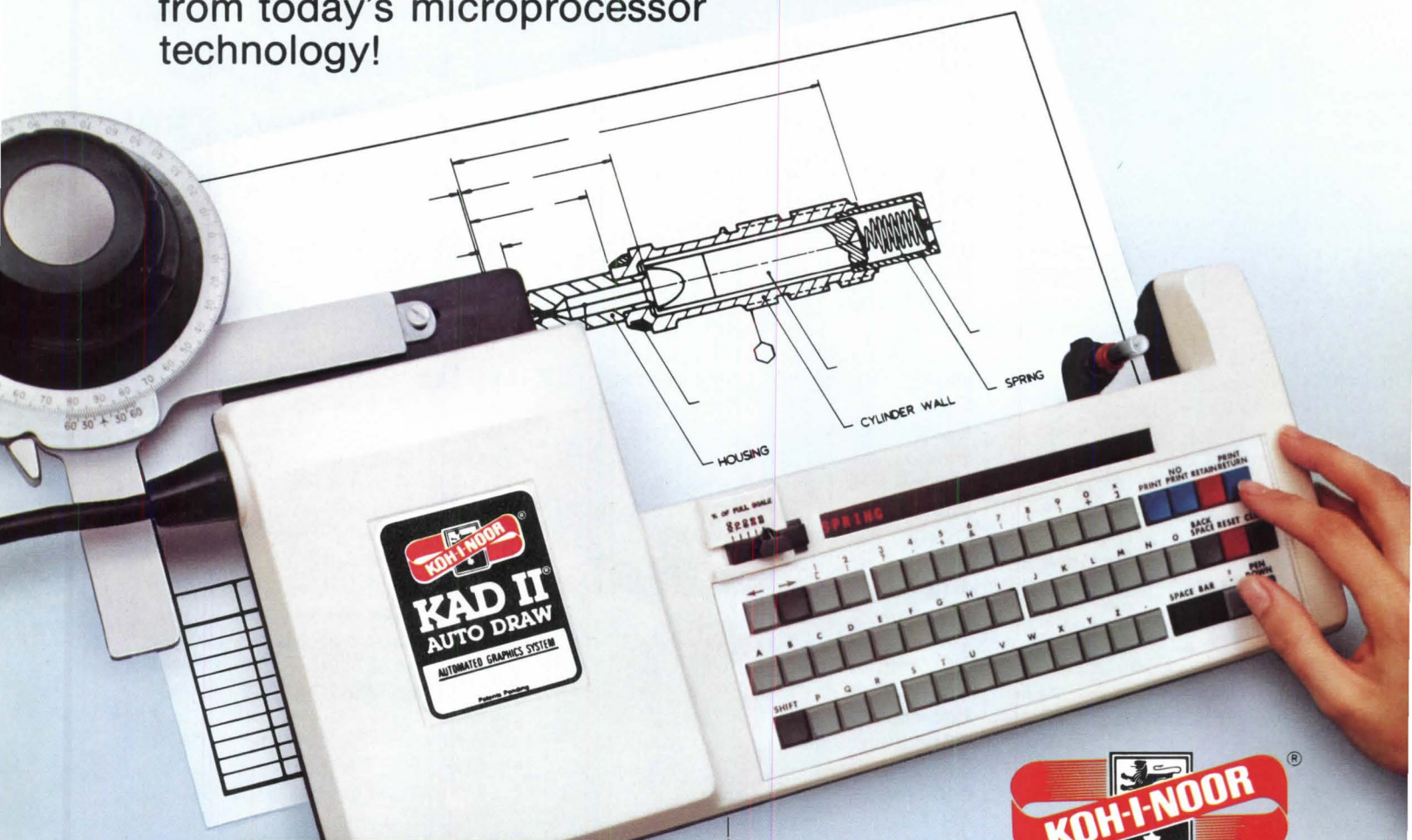

Please send me free descriptive literature for the Koh-I-Noor KAD II.

Name _____ Title _____

Firm _____

Address _____

City _____ State _____ Zip _____

KOH-I-NOOR RAPIDOGRAPH, INC., Bloomsbury, NJ 08804 800-631-7646.
In Canada: 1815 Meyerside Dr., Mississauga, Ont. L5T 1B4 800-268-4961.

AIA-8-81

UCI from page 160

H. H. Robertson Co.

Offers a 12-minute color movie on the Ultra-Flow streamline gravity ventilator. Representatives will assist in planning and engineering air make-up systems.
Contact C. J. Price, H.H. Robertson Co., 400 Holiday Dr., Pittsburgh, Pa. 15220.

UCI 16: Electrical

ADT

Information describes the CentraScan, a self-contained, computer-based life safety and security monitoring system.
Contact ADT, One World Trade Center, 122nd Floor, New York, N.Y. 10048.

Atelier International

2-page catalog features 14 floor, wall and ceiling lighting fixtures of the Lighting Quick Ship line.
Contact Ann Kapner, Atelier International, Ltd. 595 Madison Ave., New York, N.Y. 10022.

Crouse-Hinds Co.

Lighting calculator is designed to enable the lighting designer, architect or engineer to compute the most energy-efficient pole spacing and lamp wattages for the company's PMS series of Post Top luminaires.
Contact Crouse-Hinds Co., Lighting Products Division, Box 4999, Syracuse, N.Y. 13221.

Elliptipar, Inc.

Brochure details Lite-A-Part fixtures, task/ambient lighting. Information is also available that explains why, when and how to use asymmetric fixtures for uniform light distribution with low energy consumption.

Contact Anthony Stone, Sales/Marketing Manager, Elliptipar, Inc., 145 Orange Ave., West Haven, Conn. 06516.

Gardco Lighting

Audiovisual programs provide background on aspects of outdoor lighting design and engineering including optical system spacings, grid patterns, glare control, pole selection, lighting workmanship, design integrity and others.
Contact Gardco Lighting, 2661 Alvarado St., San Leandro, Calif. 94577.

General Electric Co.

Offers brochure on energy-efficient lighting products.
Contact General Electric Co., Inquiry Bureau, #1180, Nela Park, Cleveland, Ohio 44112.

GTE Sylvania Inc.

Literature provides data and specifications on the full line of fluorescent, incandescent and HID lamps and contains a

guide to lower energy costs. Additional information describes L-845 lamps, fluorescent, incandescent, HID light sources that are designed to help reduce energy consumption.

Contact GTE Sylvania Inc., Lighting Products Group, 100 Endicott St., Danvers, Mass. 01923.

Harvey Hubbell, Inc.

Controlux VLB Series, designed to provide comfortable, low brightness illumination using efficient HID energy-conserving lamps, is described in a four-page brochure.

Contact Harvey Hubbell, Inc., Lighting Division, Christiansburg, Va. 24073.

Honeywell Inc.

Information available on the firm's solar-powered airconditioning system, modular electronic control system and clock thermostats.

Contact Honeywell Inc., Honeywell Plaza, Minneapolis, Minn. 55408.

Johns-Manville

Brochure describes applications, specifications and ordering details on its full line of industrial luminaires. A worksheet for calculating the energy savings that can be gained from relighting an existing installation is included.

Contact Johns-Manville Service Center, 1601 23rd St., Denver, Colo. 80216.

Keene Corporation

Specification sheets describe the firm's line of task/ambient lighting fixtures.
Contact Ted Goldsby, Lighting Division, Keene Corporation, Industrial Way, Wilmington, Mass. 01887.

Kimball International Inc.

Information details Group Artec office systems, which feature a modular, totally integrated electrical distribution system designed to meet open office plan power requirements.

Contact Group Artec, A Division of Kimball International, Inc., 1549 Royal St., Jasper, Ind. 47546.

LouverDrape, Inc.

Offers information on LouverMatic, a remote control for vertical blinds.
Contact Sandy White, LouverDrape, Inc., 1100 Colorado Ave., Santa Monica, Calif. 90401.

McGraw-Edison Co.

Offers publications on decorative lighting fixtures, track lighting, indoor and outdoor fixtures, surface lighting, exit lights and recessed lighting.

Contact Mike Smith, PR Manager, Lighting Products Division, McGraw-Edison Co., 400 Busse Road, Elk Grove Village, Ill. 60007.

Metropolitan Furniture Corporation

Brochure features Robert Long's hood collection of lighting. Also a catalog

shows the firm's lighting designs for residential and contract applications, \$15.
Contact Alycia Umemoto, Manager, Marketing Services, Metropolitan Furniture Corporation, 950 Linden Ave., South San Francisco, Calif. 94080.

PECO Manufacturing Co., Inc.

Data sheet describes microprocessor-based temperature programmers.
Contact Don Robison, Marketing Manager, PECO Manufacturing Co., Inc., P.O. Box 02156, Portland, Ore. 97202.

H. H. Robertson Co.

TR Duct System, an underfloor electrical distribution system for concrete structures, is explained in a 12-page catalog.
Contact H. H. Robertson Co., 400 Holiday Drive, Pittsburgh, Pa. 15220.

Square D Co.

Offers brochures on electrical products for building alterations and remodeling. Bulletin describes Fire-Gard floor service fittings. Many other brochures are available on the firm's electrical raceway systems, feeder and plug-in busways, lay-in and gutter wireways, among others.

Contact Advertising Manager, Power Equipment Division, Square D Co., P.O. Box 558, Middletown, Ohio 45042.

Structural Concepts Corporation

Offers information on its Personalized Air Circulating System.

Contact Don Ott, Structural Concepts Corporation, 17237 Van Wagoner Road, Spring Lake, Mich. 49456.

Sunmaster Corporation

Information available on evacuated tube collectors used in residential, commercial and industrial solar energy heating and cooling systems.

Contact Sunmaster Corporation, 35 W. William St., P.O. Box 1077, Corning, N.Y. 14830.

Von Duprin, Inc.

Offers information on UL listed burglar and fire alarm systems as well as a broad line of electrified hardware for security control.

Contact Chuck Heckman, Sales Development Manager, Von Duprin, Inc., 400 W. Maryland St., Indianapolis, Ind. 46225.

Wiremold Co.

Brochure describes above ceiling raceway system, selection of dual-channel poles for bringing electric and communications/electronic services from above the dropped ceiling to points of use and insulated and uninsulated ducts for making connects between rigid ducts and outlets in airconditioning systems.

Contact Wiremold Co., West Hartford, Conn. 06110.

ADVERTISERS

Michael J. Hanley

Publisher

Michael M. Wood

Director of Marketing

Jesse Sims

Manager, Production and Business

1735 New York Ave. N.W.

Washington, D.C. 20006

(202) 626-7484

Lisa Hoke

Director of Operations

Suzanne Maggi

Assistant to the Publisher

ADVERTISING SALES OFFICES

Washington, D.C. (202) 626-7471

1735 New York Ave. N.W.

Washington, D.C. 20006

Philadelphia (215) 639-3731

George T. Broskey, Eastern Manager

3 Neshaminy Interplex, #301

Trevoise, Pa. 19047

New York City (212) 736-2131

Jeanne S. Cohen

390 Fifth Ave.

Suite #407

New York, N.Y. 10018

Ohio (201) 729-4937

Thomas R. Crow

46 Main Street

Sparta, N.J. 07871

New England/New York State

(617) 632-8185

Robert L. Tagen

87 State Road West

Westminster, Mass. 01473

Chicago (312) 663-4116

James A. Anderson, Western Manager

53 West Jackson Boulevard

#356

Chicago, Ill. 60604

Atlanta (214) 352-9273

J. Thomas Dorsey

3840 Valley Lawn

Dallas, Tex. 75229

St. Louis (314) 569-3210

Richard D. Grater

1466 Summerhaven

St. Louis, Mo. 63141

San Francisco (415) 348-8222

Jules E. Thompson

1290 Howard Ave., #303

Burlingame, Calif. 94010

Circle No.	Page No.	Circle No.	Page No.
27	50	1	Cov. 2
63	151	28	57
45	129	26	51
60	147	14	20-21
2	1	78	160
34	68		4-5
	40-41	36	108-109
69	156	79	162
9	11		120-121
65	153	76	Cov. 3
38	115	61	149
31	62-63	56	140
23	46	37	113
52	134-135	73	161
55	139	70	157
15	22	57	6
13	16		8-9
46	129-131	77	Cov. 4
32	64-66	12	15
59	143	49	132
41	125	33	67
25	55	58	142
20	39	29	58
24	48-49	54	138
35	107	39	117
10	12-13	30	61
62	150	3	2
43	128	64	152
72	159	16	26
68	156	44	128
19	33-36	50	133
8	10	17	27-30
47	131		16
5	7	22	44
42	127	71	158
18	32	66	154-155
11	14		

Galaxy Sun Controllers

Riviera Blinds



We challenge you to find a sun control system this beautiful.

Levolor has come up with a glare-and-temperature control system for large expanses of glass that dramatizes your original design instead of detracting from it. Overhead, Levolor Galaxy™ Sun Controller blinds redirect the sun's rays, for minimum glare, maximum summer cooling, maximum winter warmth. Used with Riviera™ blinds by Levolor at the window, as shown here, you have a total sun control system that

is a visual plus, easy to install and engineered with Levolor technological standards—the highest. A system that can be operated automatically or manually. The beautiful answer to odd-shaped, hard-to-reach special glazing situations. Our Levolor architectural consultant can answer your specific questions. Write for information: Levolor Lorentzen, Inc.,

1280 Wall St. W,
Lyndhurst, N.J. 07071

LEVOLOR®

Sun Controller Systems.
A product of Levolor Lorentzen, Inc.

Circle 76 on information card



A better way to stain wood. A better way to save money.



Architect: Wendell Lovett, FAIA, Seattle, Washington

Construction costs can be kept to a minimum with the help of Olympic Machine Staining: no weather delays, no painting scaffolds, no bare wood exposed by shrinkage.

Best of all, Olympic Machine Staining does a better job that lasts longer. More stain protection gets into the wood because it is applied uniformly on a horizontal surface, then forced deep into the fibers by rollers and brushes.

And it dries to a beautiful uniform finish. Choose any Olympic Oil Stain, semi-transparent or solid color. See your Olympic Machine Staining Dealer or write Olympic, Dept. MS, P.O. Box 1497, Bellevue, WA 98009.

Circle 77 on information card

OLYMPIC[®]
MACHINE
STAINING