

# PRIMITIVE LOOMING



JON KAY 1733 FLYING SHUTTLE  
CARTWRIGHT 1785



COUARD 1801 STILL IN USE  
WHEEL LOOM FOR INTER  
VEN PATTERNS FOR SPECIAL  
TEXTILES



# WEAVING

# SPINNING

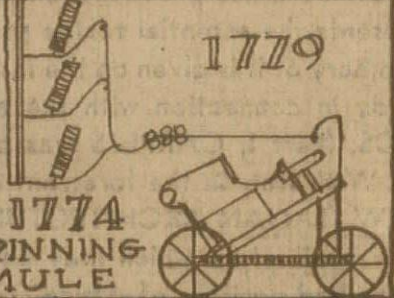

S. CROMPTON

PAUL LEWIS 1752  
1ST MECHANIZATOR

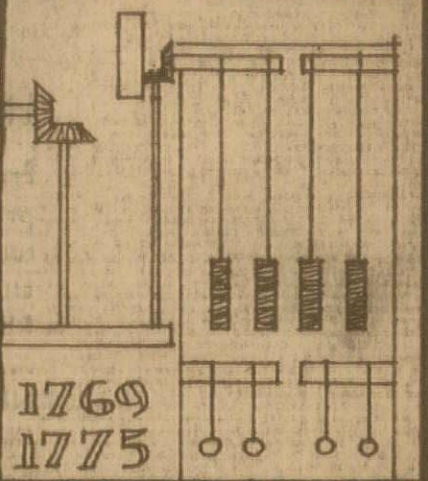

ARKWRIGHT

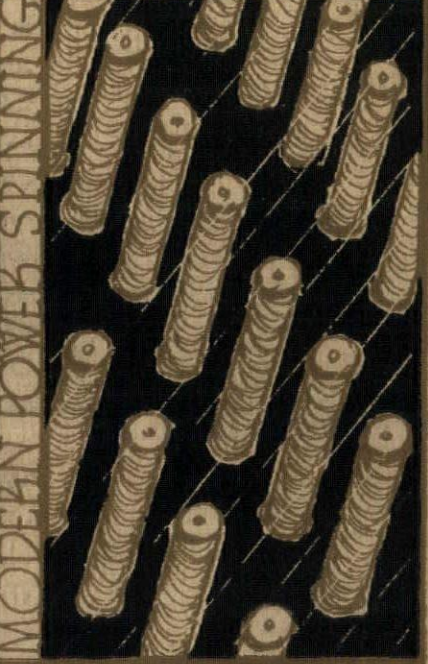

MODERN POWER SPINNING

NOVEMBER 1935 • ITALY • LeCORBUSIER • TEXTILES • TIME-SAVER STANDARDS

# AMERICAN ARCHITECT

## HIGHLIGHTS OF THIS NOVEMBER ISSUE

Ernest Born has produced an interesting cover which graphically presents the essential textile processes. An informative historical summary of it is given on the inside back cover. It deserves special study in connection with the article on TEXTILES, Part II, FABRICS; (Part I, CARPETS was presented in our September issue) . . . With Italy in the forefront of daily news and news reels, THE NEW ITALIAN ARCHITECTURE is enlightening as a forecast of the architecture which may be used in civilizing and developing backward portions of Africa. . . . LeCORBUSIER propounds stimulating ideas, as always, and his article, "LA VILLE RADIEUSE," in this issue is as provocative as are his inimitable illustrated lectures which this country is hearing now for the first time . . . THE COLONIAL LIBRARY by Smith & Bassette, which follows this exposition of modernism, is an example of a building designed to conform to its environment and serve its community in the spirit and style of local tradition . . . Modernization of THE HOUSE OF DONN JEFFERSON SHEETS, architect, shows what can be done to an almost hopeless looking farmhouse. It was awarded first prize by Good Housekeeping in its recent competition . . . Of buildings partially paid for by P. W. A., we show the U. S. MARINE HOSPITAL in Seattle, Washington, by Bebb & Gould, a modern skyscraper hospital for "gregarious" ambulatory men. What was done and why is clearly shown . . . SCHOOLS IN THE OPEN AIR are two—one in Suresnes, France, and the other in Newark, N. J. They contain new ideas in plan, design and construction . . . The new emphasis on LAND UTILIZATION VS. LAND EXPLOITATION is gaining, not only in technical circles, but in the consciousness of forward looking citizens. Louis K. Comstock tells why in this issue . . . An example of Government building is the monumental POST OFFICE in Knoxville, Tenn., by Baumann & Baumann . . . In striking light and shade, THE GRAND-DEUR THAT WAS ROME supplements and provides a contrast for The New Architecture in Italy . . . TIME-SAVER STANDARDS presents this month an unusually useful and comprehensive series of pages which give the architect all the essential data in the designing of SEWAGE DISPOSAL SYSTEMS.

..attractive floors that

# MEAN BUSINESS !

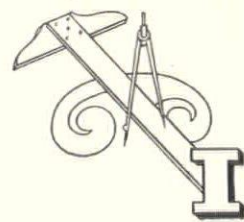

**I**N retail stores, colorful custom-designed floors of Armstrong's Linoleum can increase your client's sales by guiding customers to back-of-the-store displays that might otherwise be overlooked. And by being unlike other floors in town, they can serve to "trade - mark" your client's store in his customers' minds. He'll appreciate both these advantages.

He'll also appreciate the low cost, long life, and inexpensive maintenance of Armstrong's Linoleum Floors. Armstrong's Linoleum requires only simple washing and waxing to keep it fresh and beautiful for years. Expensive refinishing are unnecessary.

For complete information on the design possibilities of Armstrong's Linoleum, write now for file-sized "Public Floors of Enduring Beauty." For colors and grades, see Sweet's, Section 15, Catalog 35. Armstrong Cork Products Co., Building Materials Division, 1201 State St., Lancaster, Pa.



## Armstrong's L I N O L E U M F L O O R S

*BELOW—Hats and shirts, inset in a field of Armstrong's Pattern 09 Marbelle Linoleum individualize this floor of Armstrong's Linoleum in the Harry Kraus Shirt Shop, Indianapolis.*



*ABOVE—This custom-cut Armstrong's Linoleum Floor in sportswear department of Elder and Johnston Company, Dayton, is Armstrong's Plain Linoleum in ruby, black, orange, jade, and tan. Armstrong's Architects' Service Bureau offers, without charge, complete technical assistance in the design of modern floors.*

*RIGHT—In main sales room of Seliz Clothing Company, San Francisco, floor is Armstrong's Pattern 01 and Pattern 017 Marbelle Linoleum, with black linoleum borders and interliners.*

*BELOW—Plain and Jaspe Linoleum form this custom-cut Armstrong Floor in shop of Duane Bakers, Baltimore. Colors are brown and tan.*



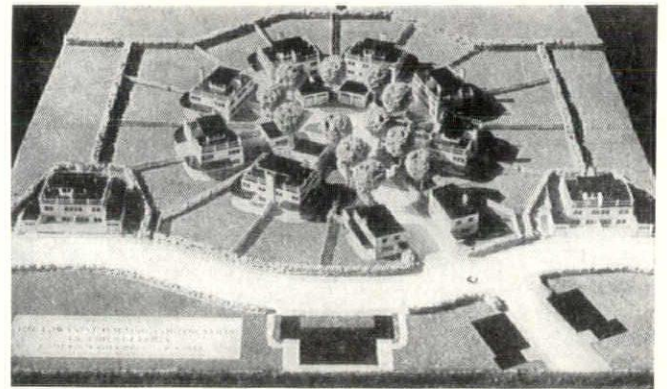

Illustration from "Housing In Philadelphia." At the left, a sculptured group by Henri Bouchard and Paul Landowski, in "The New Architectural Sculpture"

### THE NEW ARCHITECTURAL SCULPTURE

By Walter Raymond Agard. Published by the Oxford University Press, New York. Cloth bound; 6 1/4 x 9 1/4; illustrated; \$3.

IN seeking a fuller realization of the esthetic possibilities in modern architecture, our architects are wisely calling more and more upon sculptors for collaboration. Architectural sculpture, in order to keep pace with the new architecture, has naturally undergone many radical changes. In this volume, Mr. Agard depicts these changes; describes and appraises their development. He shows how modern sculptors are co-operating with architects in Europe and America in the creation of public buildings, skyscrapers, churches, homes, and memorials to meet the needs of our times. The book includes 32 beautiful plates comprising 42 illustrations of especially significant modern architectural sculpture. Among the works illustrated are those of Lee Lawrie, Bourdelle, Mestrovic, Milles, Jan and Joel Martel and Hans Panzer. While the majority of the examples have been published hitherto in the architectural press, this does not detract from their value in this volume. Mr. Agard is also the author of "The Greek Tradition in Sculpture" and "Modern Sculpture."

### SPECIFICATION DOCUMENTS

By David H. Merrill and Theodore C. Combs. Published by R. C. Collins & Associates, Los Angeles, Calif. Cloth cover; 522 pages; 9 1/4 x 6 1/4; price \$5.

INCLUDED under one cover for the first time are all specifications on building materials and construction referred to in the Uniform Building Code of the Pacific Coast Building

Officials Conference under which 150 cities and counties in the United States operate. There are 63 standard and tentative specifications and test programs compiled from many sources, classified and arranged for ready reference. Part 1, Basic Materials; Part 2, Fire Resistive Standards; Part 3, Appurtenances; Part 4, Equipment. These documents are legally a part of the Code. Architects, engineers, contractors and building officials should find the collection of value. Specifications are amplified by many drawings and illustrations. The book is available on order from Pacific Coast Building Officials Conference, 124 West 4th Street, Los Angeles.

### HOUSING IN PHILADELPHIA

By Bernard J. Newman. Published by the Philadelphia Housing Association. Paper bound booklet; 38 pages; price \$0.25.

HERE is a frank discussion of slum clearance and low-cost housing with particular reference to the problems encountered by the Philadelphia Housing Association. It is of more than local significance as the basic problems are practically the same as exists in every metropolitan community. Five typical projects proposed by architects for limited dividend housing under the Public Works Administration are included with illustrations, and a comprehensive description of each proposal. There are chapters on: "Can We Afford to Build?," "Dwelling Construction," "Demolitions," "Sheriff Sales," "Rent Study," and "Insanitation." Anyone interested in the Federal Housing Program will find this booklet both timely and interesting.

### MODERN SURVEYING FOR THE CIVIL ENGINEER

By Harold Frank Birchall. Published by the Sherwood Press, Cleveland, Ohio. Cloth; 524 pages; illustrated; price \$8 net, postpaid.

THE author of this work has endeavored to give the civil engineer a practical working knowledge of conditions in the field, with such specialized information as to constitute a guide to the best practice in surveying beyond the limits of the simple academic theories on the subject. Chapters are included on the practice of surveying, estimating and laying out of works of all kinds, with special emphasis on photographic and aerial surveying as applied to engineering enterprises. There are some 382 figures, many half-tone plates, and 14 folding plans. The experience of the author's twenty-five years practice as an engineering surveyor in various parts of the world is given in this volume. Many architects will find it useful.

### ANALYSIS OF FRAMED STRUCTURES

By John H. Matthews and Phillip E. Soneson. Published by McGraw-Hill Book Co., Inc., New York, N. Y. Illustrated; indexed; 318 pages; size 6 1/4 x 9; price \$3.50.

THIS book is intended to serve as an outline and guide for students in courses treating of the analysis of stresses in simple structures, and as such comes rather more in the province of the engineer than that of the architect. Nevertheless, because of its logical and clear arrangement of material and its simplified elucidation of the principles of analysis and solution, many architects may find it useful as a reference book. Both the authors are instructors in structural engineering at Purdue University.

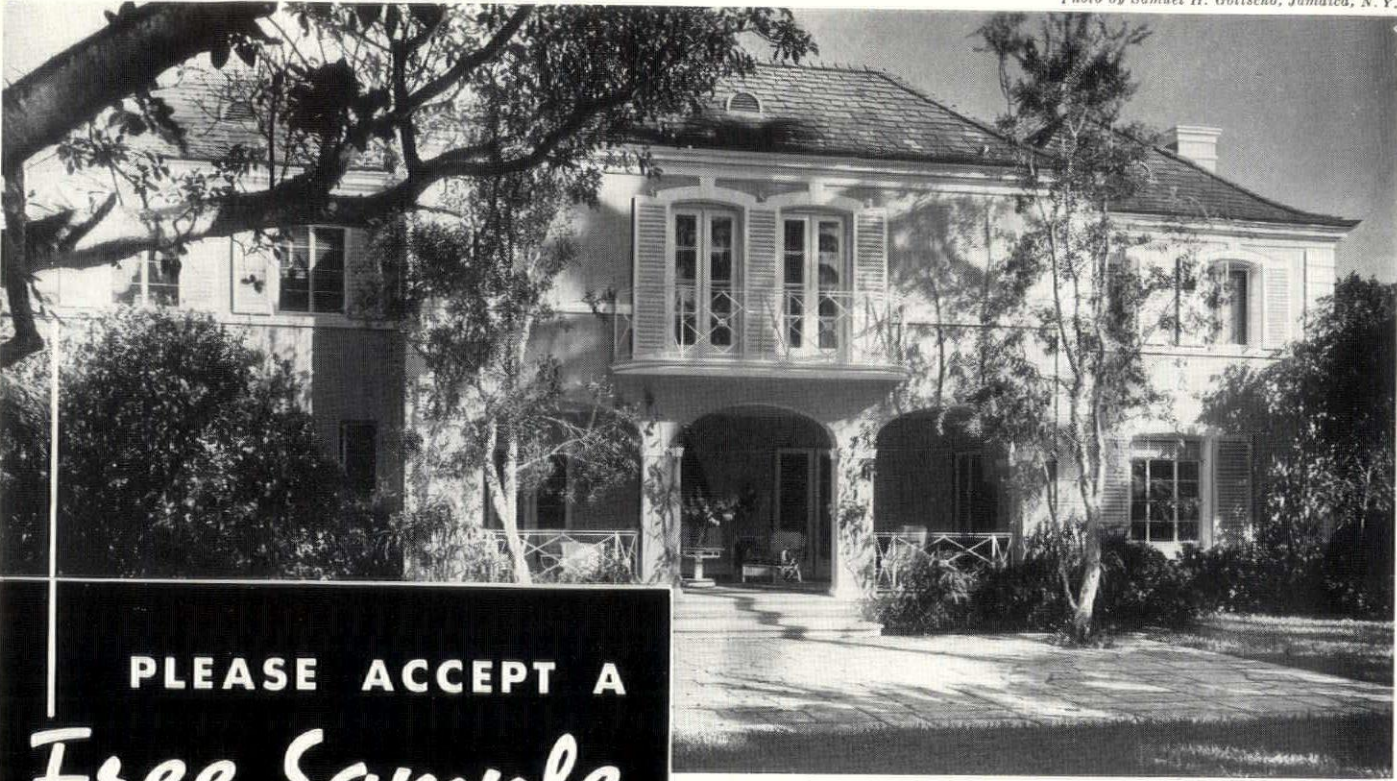

Charming garden façade of the residence of Maurice Fatio, Via Vizcaya, Palm Beach, Florida. Built-in conduit, connecting six outlets, provides for telephone convenience. . . . Architects, TREANOR AND FATIO, Palm Beach.

PLEASE ACCEPT A  
*Free Sample*  
OF OUR SERVICE

SOCIAL and business life today depends so largely upon the telephone that no home is quite modern without adequate telephone facilities. Many architects provide for them as carefully as for electric lights or heating systems. And to assist in this pre-planning, telephone companies offer the service of trained technical staffs, without charge.

Co-operation between architect and telephone engineer is highly desirable for a number of reasons. Telephone conduit costs much less to install during construction than later. Extra outlets can be located in anticipation of future needs. Then, as families grow up, telephone service can be easily extended without the necessity of piercing finished walls and floors and without exposing the wiring.

Feel free to make full use of your telephone company's specialized knowledge. It will save money for the owners of the homes you design or remodel — will make those homes more comfortable, more efficient. Just call the Business Office and ask for "Architects' and Builders' Service."

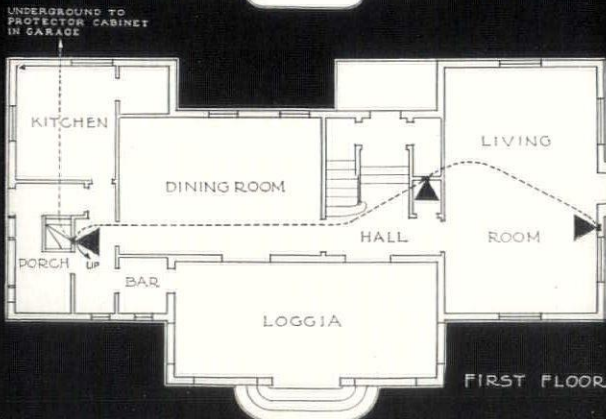
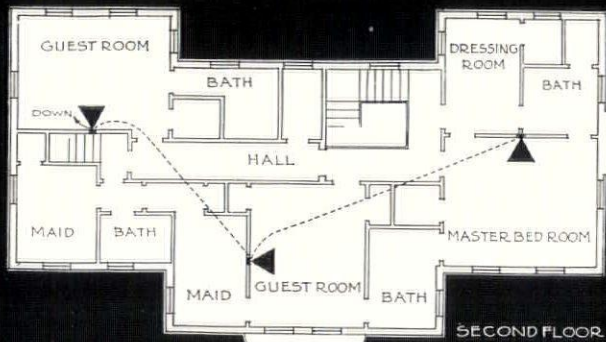

LEGEND ◀ TELEPHONE OUTLET ----- CONDUIT

FOR FURTHER INFORMATION ON  
BELL SYSTEM TELEPHONE SERVICES  
AND EQUIPMENT, SEE SWEET'S CATALOGUE



American Architect, published monthly by International Publications, Inc., 572 Madison Avenue, New York, N. Y., \$3.00 per year; Canada, \$4.00; Foreign, \$5.00. Entered as second class matter April 5th, 1926, at the Post Office at New York, N. Y., under the act of March 3rd, 1879. Issue 2639, dated November, 1935.

# HERMAN NELSON CORPORATION

## READY TO SERVE

**T**HE President, during the past few weeks, has approved allotments to finance thousands of PWA projects. A very large percentage of these projects are public school buildings. In order that the President's stipulations regarding construction schedules may be met, school authorities and their architects and engineers will be very busy during the next few months. In spite of the many things to be done during the short time available, these school authorities, architects and engineers will wish to give careful consideration to the air conditioning problems which the construction of these schools presents. • The Herman Nelson Corporation offers the co-operation of its entire organization in this work. Its representatives throughout the country are at the service of those responsible for the air conditioning of these schools. Each of these representatives is a specialist in school classroom air conditioning. All but a few of them spend their entire time in this class of work. On these pages we list them with their addresses. Any school authority, architect or engineer who desires the assistance and co-operation of this organization is requested to get in touch with the nearest representative, or with the Home Office at Moline, Illinois.

### Representatives

- |  |  |  |
|--|--|--|
| CALIFORNIA, San Francisco<br>F. J. Hearty & Co.<br>Room 407 Call Bldg.     | MINNESOTA, Minneapolis<br>Reese & Bredesen<br>410 Essex Bldg.    | PENNSYLVANIA, Johnstown<br>H. F. Lenz<br>Dibert Building                         |
| COLORADO, Denver<br>J. M. Appleton<br>812 12th Street                      | MISSOURI, Kansas City<br>Disney-Leffel Co.<br>Karnopp Building   | PENNSYLVANIA, Philadelphia<br>Thos. Feigley<br>Room 222, Ins. Co. of N. A. Bldg. |
| DIST. of COLUMBIA, Washington<br>Chas. S. Stock<br>Room 202, Barr Building | MISSOURI, St. Louis<br>C. A. Pickett<br>3135 Olive St.           | PENNSYLVANIA, Pittsburgh<br>H. A. Beighel<br>503 Columbia Bank Bldg.             |
| ILLINOIS, Chicago<br>Carl Frantz<br>Suite 332, 520 N. Michigan Ave.        | MONTANA, Missoula<br>W. M. Walterskirchen<br>P. O. Box 1163      | TENNESSEE, Memphis<br>W. K. Hornbuckle<br>242 Madison Ave.                       |
| ILLINOIS, Moline<br>W. J. Lindsey<br>c-o The Herman Nelson Corp.           | NEBRASKA, Omaha<br>K. J. Murray<br>2205 Ellison Ave.             | TENNESSEE, Nashville<br>Paul R. Jarratt<br>117 Fifth Ave., North                 |
| INDIANA, Indianapolis<br>Geo. Heidenreich<br>1300 Inland Bank Bldg.        | NEW YORK, Buffalo<br>Park S. Hedley<br>304 Curtiss Bldg.         | TEXAS, Dallas<br>W. E. Lewis & Co.<br>508 Construction Bldg.                     |
| KANSAS, Emporia<br>C. W. Burnap<br>724 Commercial St.                      | NEW YORK, New York City<br>R. A. Kent<br>Room 771, 50 Church St. | UTAH, Salt Lake City<br>Rushby C. Midgley<br>412-13 Dooly Bldg.                  |
| MAINE, Portland<br>Geo. A. Partridge<br>12 Monument Square                 | NEW YORK, Rochester<br>A. R. Bowman<br>Room 703, Temple Bldg.    | VIRGINIA, Richmond<br>W. Wallace Neale<br>302 Carneal Bldg.                      |
| MASSACHUSETTS, Boston<br>W. N. Murray<br>Room 1134, Statler Office Bldg.   | NEW YORK, Schenectady<br>C. H. Pease<br>1153 Keyes Ave.          | VIRGINIA, Roanoke<br>Carroll G. Traylor<br>301 Liberty Trust Bldg.               |
| MASSACHUSETTS, Westfield<br>J. E. Carey<br>7 Charles St.                   | OHIO, Dayton<br>A. W. Rooks<br>58 Redder Ave.                    | WASHINGTON, Spokane<br>Heating Assurance, Inc.<br>121 N. Browne St.              |
| MICHIGAN, Detroit<br>Knight-Randall Co.<br>8316 Woodward Ave.              | OREGON, Portland<br>J. C. Ross & Co.<br>917 S. W. Oak St.        | WASHINGTON, Tacoma<br>H. L. Swindler<br>41 St. Helens Ave.                       |
|  | PENNSYLVANIA, Harrisburg<br>P. A. Cavanagh<br>1619 Green St.     | WISCONSIN, Milwaukee<br>C. W. Miller<br>338 S. Second St.                        |

**THE HERMAN NELSON CORPORATION**  
*Heating, Ventilating and Air Conditioning Equipment for Schools*  
**MOLINE, ILLINOIS**



HERMAN NELSON *System of*  
*Air Conditioning for Schools*

© The Herman Nelson Corporation, Moline, Illinois

# The Readers

## Have a Word to Say

### • CHECK, & DOUBLE CHECK

*Editor, AMERICAN ARCHITECT:*

ENCLOSED please find a check for one dollar for which please enroll me as a member of your Time-Saver Standards Service.

I am very glad of the opportunity to obtain these sets in one group, as we have found them very valuable in our office. For instance, the information contained in the sets giving booth dimensions, was very useful to us recently, when we were laying out a small restaurant. And further this was the only handy source of information along these lines.—*Beck & Tinkham, Architects, Jamestown, New York.*

### • HUMAN BODY FREE

*Editor, AMERICAN ARCHITECT:*

I AM a subscriber to the AMERICAN ARCHITECT and would appreciate receiving the Time-Saver Standards Data Sheets that you are going to distribute free of charge.

May I suggest that you include some of Freese's Geometry of the Human Body, that you have published in articles before.—*Ernest A. Schneider, Pittsburgh, Pa.*

So shall it be! Ed.

### • A BOON

*Editor, AMERICAN ARCHITECT:*

YOU are to be complimented. The Time-Saver Standards Service is what every architect and draftsman has been looking for.

While we have done Commercial, Industrial and Institutional work, the backbone of our practice has been residential. Your service will be a "Boon" to the residential architects.

Wish you every success in this new undertaking.—*Manske and Rotty, Architects, St. Louis, Mo.*

### • FARE FOR HARVARD

*Editor, AMERICAN ARCHITECT:*

WE have seen your advertisement of AMERICAN ARCHITECT Time-Saver Standards Service in the October, 1935 issue of AMERICAN ARCHITECT.

Will you kindly enroll the School of Architecture Library, Robinson Hall, Harvard University, Cambridge, Mass. to receive without charge the Time-Saver Standards sheets as issued.

We subscribe regularly to AMERICAN

ARCHITECT.—*Ruth V. Cook, Librarian, Harvard University, Cambridge, Mass.*

### • HANDY, INSPIRATION

*Editor, AMERICAN ARCHITECT:*

I AM enclosing Postal Money Order for seven dollars to cover my subscription to AMERICAN ARCHITECT for three years at six dollars, plus one dollar for your new TubaK Binder for Time-Saver Data sheets and index.

Please send me the Time-Saver sheets as they are published. So far we have found them very handy in the office. I think your idea the best yet—and should be an inspiration to manufacturers to put up their information in as concise a manner as you have.

Wishing you heaps of luck.—*Harold H. Gardner, Pontiac, Michigan.*

### • WHAT BINDERS

*Editor, AMERICAN ARCHITECT:*

ENCLOSED please find application for Time-Saver Standards, I have plenty of loose leaf folders and binders to properly hold and protect same. I feel that these sheets are of great importance and value and I appreciate your efforts and good work.—*Raymond T. Dunn, Peekskill, N. Y.*

Sheets of Time-Saver Standards are not punched for ordinary ring books, but have special die-cuts to fit newly perfected binder. Ed.

### • THE BEST YET

*Editor, AMERICAN ARCHITECT:*

ENCLOSED please find application with one dollar in cash attached for the required enrollment to receive, without charge, AMERICAN ARCHITECT Time-Saver Standard Sheets.

These sheets are the best thing I have seen to be of real value in an architect's office.

I wish you success and remain,—*Peter A. Tiagwad, Architect, Ridgewood, N. J.*

### • PROFIT THE PROBLEM

*Editor, AMERICAN ARCHITECT:*

IN further regard to the matter of a plan of publicity for the architectural profession.

I have personally known of examples where a real estate agent obtains the exclusive right to the sale of a piece of property, hangs out a sign and a buyer walks into his office, buys the

property, and the agent was paid a fee of 10 per cent for those "services" running from the sum of \$1,000 and more.

I have yet to know of any architect's office that obtained fees that produced relatively the same profits.

Real estate agents can afford to organize and can afford to conduct promotional campaigns in behalf of their "profession."

On the other hand, at the A. I. A. fee of 6 per cent architects cannot do so, for the profits on the average work at this rate are little indeed, if any, using the term profits rightly, not referring to cost of one's labor or to the cost of overhead.

And what about the majority of architects in the small towns and big cities alike, who are busy cutting this 6 per cent fee in an endeavor to get the work away from the other fellow? Where is their profit?

Here then is a problem. Until our profession learns to obtain fees that produce a profit, although one must be an optimist to hope they might equal the business acumen of a real estate agent, how can it hope to co-operate in obtaining such fees and putting forth proper publicity that would make same possible and so they could pay for same?

In the meantime, instead of belittling the real estate agent, it seems to me, he commands our respect and envy, at least as a business man.—*Harry Lucht, Architect, Cliffside Park, N. J.*

### • A MATTER OF EDUCATION

*Editor, AMERICAN ARCHITECT:*

PERHAPS a retired artist and architectural student may venture a criticism? The writer has time to read, study and think, having come through the depression with sufficient income to supply her modest needs.

In your September issue the plan for reforming New York's Harlem district simply makes my artistic perceptions ache. The view of present conditions is full of pictures. The improvement looks like a machine-drawing submitted to the patent office for Uncle Sam's O.K.

Now you just can't clean up a settlement of negroes that way; nor in fact any slum district yet written or spoken of. It has to be a matter of education, largely. Slum-dwellers will not try to keep property neat and orderly. The

(Continued on page 109)



# Easy to design and install

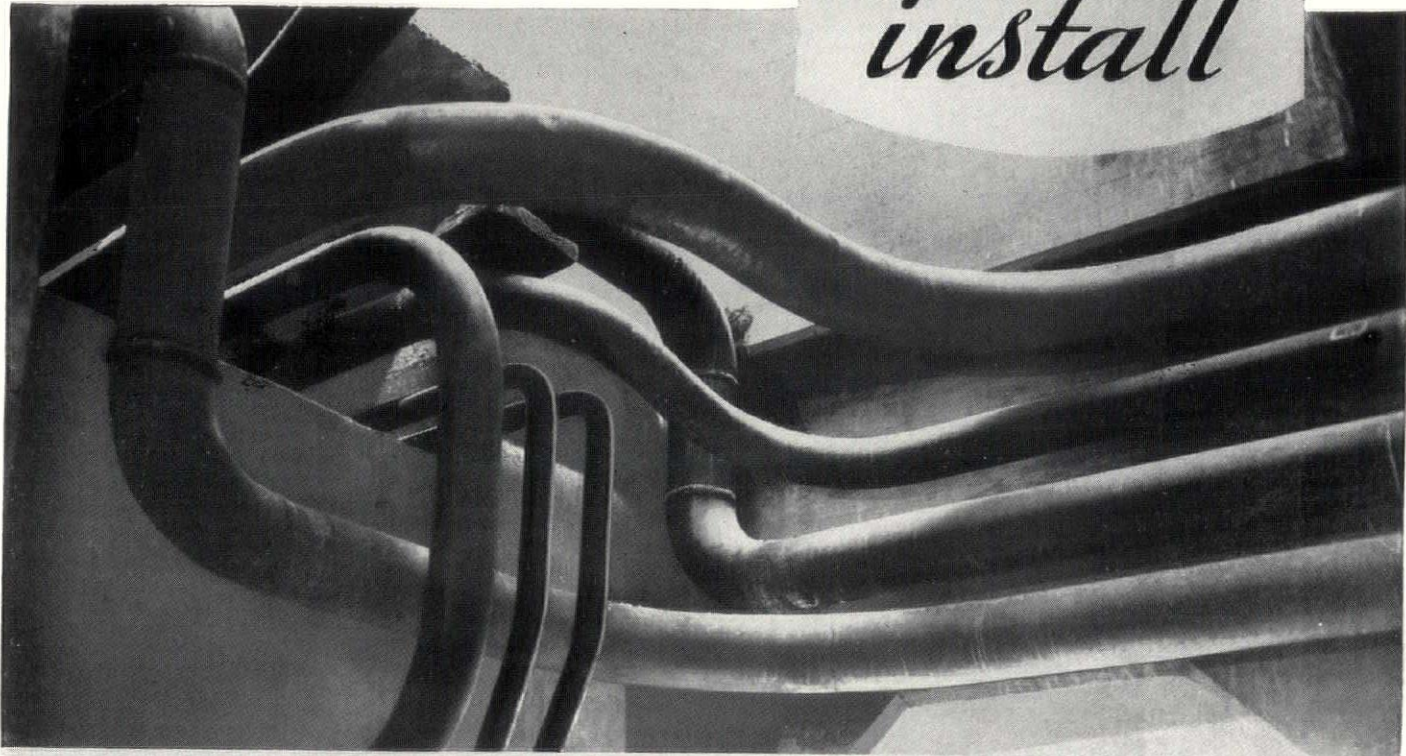

## • OXWELDED PIPING •

**O**XWELDING materially simplified this piping system for both the architect and the contractor. Design was freed from the limitations of standard fittings. Bends, valves and specials were quickly located without consideration of exact lengths of connecting pipe. Construction was fast and sure.

An oxwelded piping system is one permanent whole . . . just as if it were constructed from a continuous piece of pipe! It takes up less space, looks neater, is easier and less costly to insulate and, most important, welds are fully as strong as the original pipe and forever maintenance free.

You can specify oxwelding for pipe of all sizes—any material—with complete confidence in the permanent economies which this modern construction will bring to your buildings.

### *Specifications for Welded Piping*

Linde engineers have prepared clear and concise technical data especially for the architect interested in designing and specifying jointless piping systems that will remain leakproof forever. Ask the Linde Office in your city for complete details or write to the company at 30 East 42nd Street, New York, N. Y. Address, The Linde Air Products Company, Unit of Union Carbide and Carbon Corporation.

## *Everything for Oxy-Acetylene Welding and Cutting*

LINDE OXYGEN • PREST-O-LITE ACETYLENE • OXWELD APPARATUS AND SUPPLIES

FROM

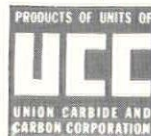

LINDE

UNION CARBIDE

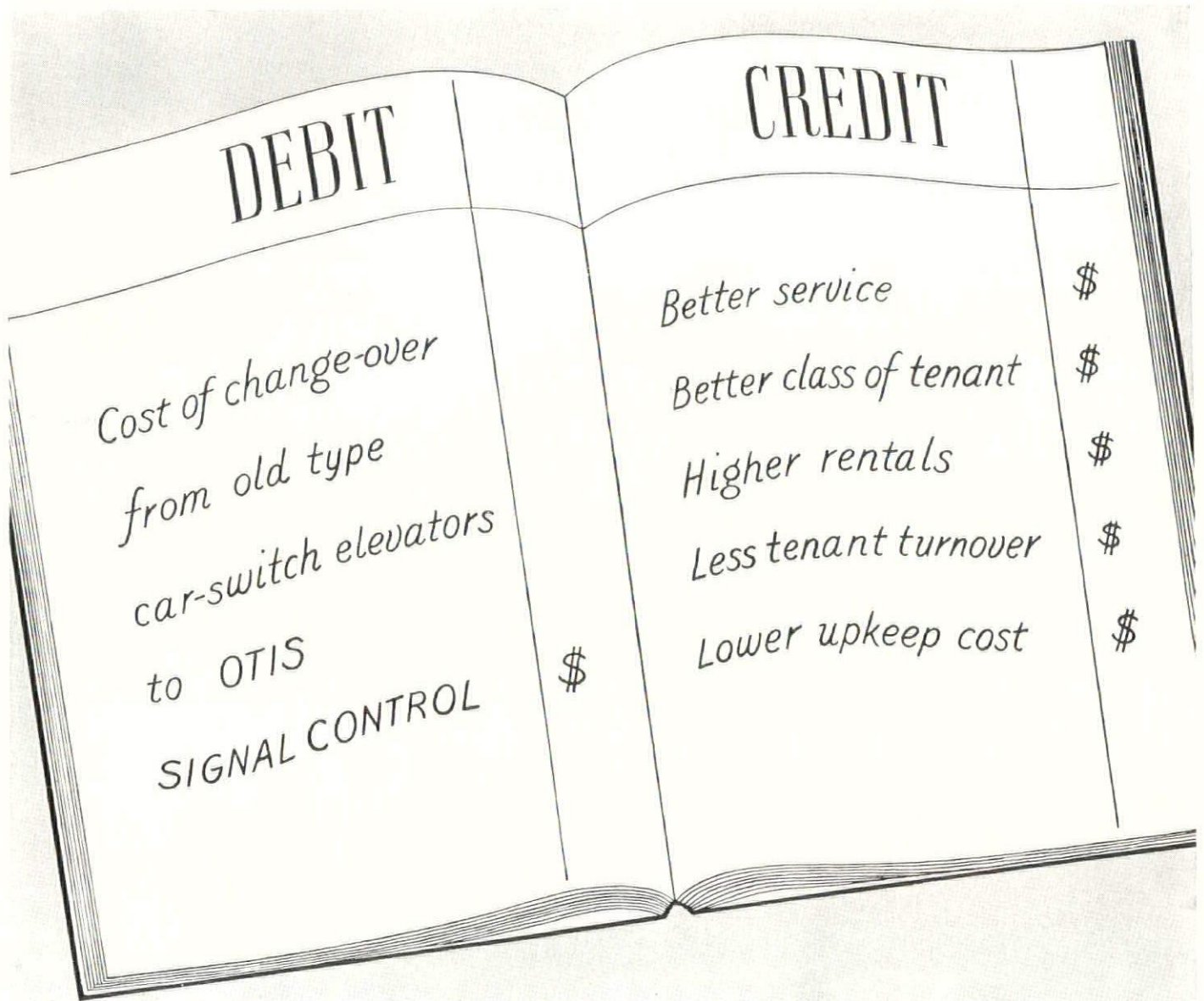

## Submit this graphic picture to modernization prospects

BUILDING managers who have made the above entry in their ledgers are finding that the credit side soon wipes out the debit.

There are some very definite reasons why the change-over from old type car-switch elevators to Otis Signal Control is a profitable investment. The change brings faster elevator speeds, less waiting time, a saving in stopping time at the various floors, greater comfort to passengers. These obvious elevator improvements put the building on more favorable footing to compete

with the newer structures, help attract more tenants, and keep present tenants satisfied with their quarters. The change-over to Signal Control also reduces elevator operating expenses and prolongs elevator life.

We shall be glad to co-operate with you in any way on an elevator modernization project of this character, or, for that matter, any type of elevator modernization problem.

**OTIS ELEVATOR COMPANY**

# AMERICAN ARCHITECT

Trade-Mark Reg. U. S. Patent Office

VOLUME CXLVII

NUMBER 2639

KENNETH KINGSLEY STOWELL, A.I.A.,  
*Editor*

ROGER WADE SHERMAN,  
*Managing Editor*

TYLER STEWART ROGERS,  
*Technical Editor*

R. F. GARDNER, *General Manager*      T. W. TOWLER,  
*Advertising Manager*

Essential Textile Processes Cover Design by Ernest Born	
Forum Mussolini.....	10
The New Italian Architecture.....	11
By Pasquale Carbonara, Bruno Funaro and Eugene Raskin	
"La Ville Radieuse".....	16
By Le Corbusier	
Richard Salter Storrs Library, Longmeadow, Massachusetts... Smith & Basette, Architects	19
A Prize Winning Modernization.....	23
Donn Jefferson Sheets, Architect	
U. S. Marine Hospital, Seattle, Wash.....	28
Bebb & Gould and John Graham, Associate Architects	
The Fresh Air School, Suresnes, France.....	34
Eugene Beaudouin and Marcel Lods, Architects	
The Open Air School, Newark, N. J.....	38
John T. Simpson & Brown Rolston, Architects	
Utilization vs. Exploitation.....	40
By Louis K. Comstock	
U. S. Post Office and Court House, Knoxville, Tenn.....	42
Baumann and Baumann, Architects	
Sculpture in the U. S. S. R.....	46
The Legal Side of Architecture.....	47
By Clinton H. Blake	
—and the Grandeur That Was Rome.....	49
As It Looks to the Editors.....	58
Trends and Topics of the Times.....	60
Textiles . . . Part II—Fabrics.....	63
By Carl T. Sigman and William J. Ward, Jr.	
Time-Saver Standards.....	73
The Building World.....	89
Books.....	2
The Readers Have a Word to Say.....	6
New Catalogs.....	103
New Materials.....	105

AMERICAN ARCHITECT. Published monthly by International Publications, Inc., 572 Madison Avenue, New York. Other Offices, 919 N. Michigan Avenue, Chicago; General Motors Bldg., Detroit; 132 Newbury Street, Boston. William Randolph Hearst, President; Richard E. Berlin, Vice President; John Randolph Hearst, Vice President; Arthur S. Moore, Secretary. Copyright, 1935, by International Publications, Inc. Single copies, \$1.00. Subscription: United States and Possessions, \$3.00 per year; Canada, \$4.00; Foreign, \$5.00. Entered as second-class matter, April 5, 1926, at Post Office, New York, under Act of March 3, 1879. American Architect is protected by copyright and nothing that appears in it may be reproduced either wholly or in part without special permission.



# THE NEW ITALIAN ARCHITECTURE

How from firm-rooted classic tradition, Italian architects evolve a strong national expression, first justifying, then sanctioning and now embracing the simplicity of functional design,—is told by Pasquale Carbonara\*, Bruno Funaro\* and Eugene Raskint

**T**O understand the Italian architecture of the present it is necessary to become familiar with its background and to realize that the new architecture is the result of a slow and difficult evolution, rather than the passive acceptance of a changing fashion. It was obviously harder to abandon the dogma of classicism in Italy than in other countries such as America, where the use of classic forms was more or less of a cultural exercise; not, as in Italy, a sacred debt to a great artistic heritage.

In Italy it was not enough to prove that modern architecture is capable of producing beauty and utility; one had to show that the Italian architectural traditions were not being broken too drastically. In fact, most architectural debates (of which there were many!) dealt with the question of whether or not modern architecture could be Italian, in the sense of being a national art. Only after this battle was won, could the subject of esthetic validity arise.

The conflict is not merely one of today or of yesterday. To realize its hoary age, one need only recall the disputes between traditionalists and innovators that centered about the building of the Cathedral of Milan in 1386. Even then there was an army of foreign architects bringing in new and revolutionary ideas to attack the phalanxes formed by Italian designers around their cherished Roman traditions. To use the words of critic Roberto Papini, "... There was an old architectural world resisting death, and a new one impatient to be born," 550 years ago.

Before the World War, architecture in Italy, as everywhere, was seeking release from stagnation. The reaction against classicism was being led by D'Aronco and Basile (as by Hanker and Horte in Belgium, Behrens and Wagner in Germany and Austria). The dissatisfaction with the pseudo-stylistic compromises which this school created, gave

rise to a wave of bolder philosophies, represented in France by Perret, in America by Wright, in Holland by De Klerk, and in Italy by Antonio Sant'Elia, the futurist. Sant'Elia died at the front in 1916, leaving only a few designs and his famous writings upon which so much of the succeeding architectural thought was to be based. His formulation of the futurist philosophy is remarkable for its clarity: "Futurist architecture is the architecture of calculus, of daring, and of simplicity. . . . But since it is synthesis, expression, it remains an art, rather than an arid combination of practicability and utility. Architecture must try to harmonize man and his material environment freely and audaciously, that is, to make the 'world of things' (reality) a direct projection of spirit." Today, twenty years later, these words are considered more true than ever by the progressive architects of Italy, although during the years of the war, and even later, when architectural problems were again approached, the ideas of Sant'Elia were forgotten, or misunderstood. Only after modernism had conquered traditionalism were his philosophies "rediscovered" and appreciated.

During the early post-war years there began to be felt the need for a new architecture to express and serve the needs of a new national life. As if in recognition of this need for the rehabilitation of architecture, there was established in 1920 the Royal School of Architecture, Rome. The attitude of the new school was stated by Professor Gustavo Giovannoni (member of the Accademia d'Italia and present director of the School) to be such that,—“The history of architecture should be studied not merely for the purpose of creating the ability to reproduce antique forms, but with an analytic approach; so that the student may discern the permanent from the passing . . . to act as a guide in formulating the laws of esthetics. . . . Once again the experience of the past will stimulate the growth of new life.”

\**Institute Superiore di Architettura, Rome.* †*Department of Architecture, Columbia University.*



1



2



3

FOTOS: ENIT

WITH STRONG TRADITIONAL INFLUENCE

1. Aeronautics Administration Building, Rome
2. Postal and Telegraph Office Building, Grosseto
3. Military Barracks, Littorio

Everyone in Italy, architects, critics, authorities and laymen, agrees with this idea. But how many different interpretations are given to it! Some theorists believe that the essential point is to preserve a coherence between the architecture of today and that of the past. And although various architects have approached the problem from diametrically opposed points of view, they are all convinced, in good faith, that they are creating this harmony between old and new.

Speaking generally, there are two major schools of architectural thought in Italy; the conservatives and the rationalists. The first follows the classic formalism—simplifying, modifying and “modernizing” superficial details only. The second group, the rationalists, tries to preserve merely the spirit or atmosphere of classicism, without regard to form or *parti*.

As an example of the “conservative” approach the Forum Mussolini by the architect Del Debbio may be studied, while the rationalist attitude is well illustrated by the R. R. Station at Florence, designed by a group of younger architects.

These particular buildings are not the ultimate expressions of the philosophies which they represent, but merely clear evidence of states of mind which are still in the process of formation. In fact, there are no absolutely crystallized architectural

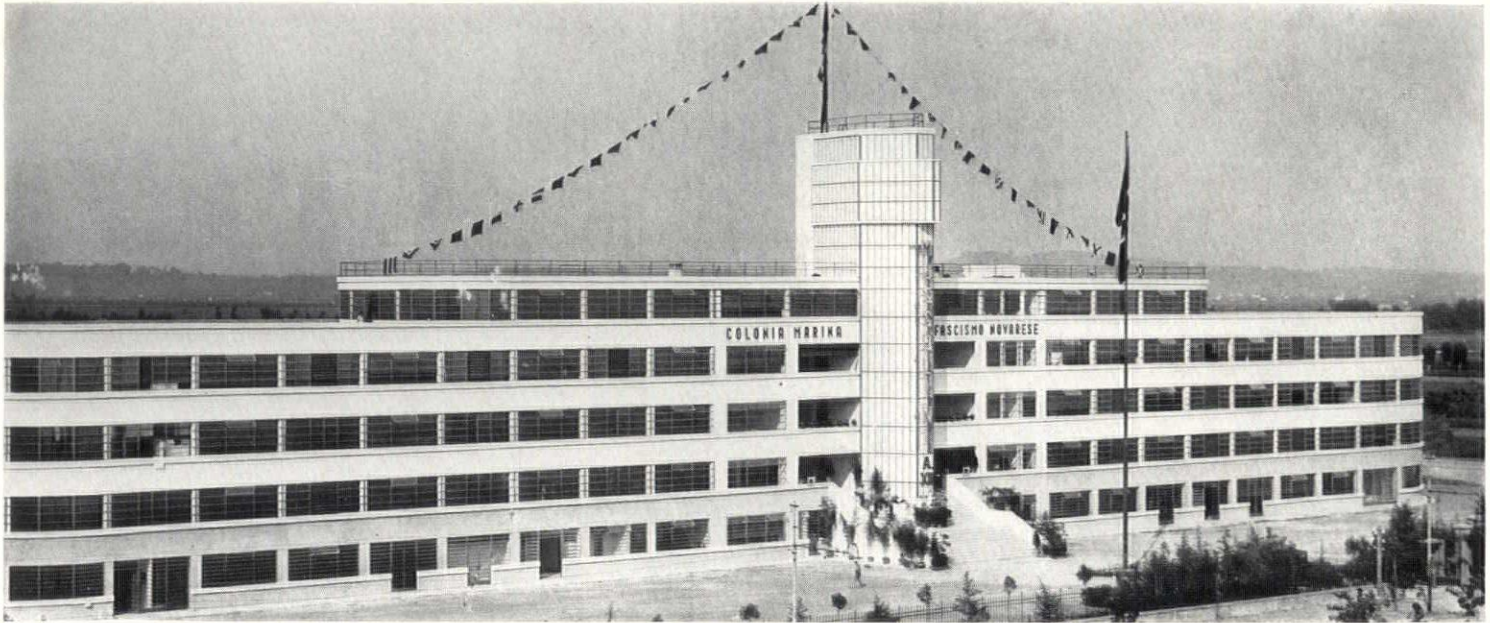

4

WITH FUNCTION TAKING PRECEDENCE

- 4. Marine college overlooking the sea, Rimini
- 5. Stadium Giovanni Berta, Florence
- 6. The new railway station in the city of Anzio

philosophies in Italy today, just as there are no recognized "maestri" to lead the way on paths which they have cleared. Even in the schools, students are not taught any rigid formulas, but are encouraged to work out new, individual solutions, expressive of their architectural fertility. This educational method, as time goes on, tends to lessen the difference between the two major factions referred to above, since the individual approach gradually replaces the partisan.

The strong urge which Italian architects have had to keep faith with the past caused them, during the period of debate over modernism, to seek some sort of justification in precedent. Some pointed to certain old buildings in the south (and on such islands as Capri) as very similar to the planar quality of modern design. Others called attention to the buildings which formed the background of Giotto's frescos. Were not these, according to Gio. Ponzi, editor of *Domus*, sufficient proof of the traditional authenticity of "modern" forms?

Another factor of importance in Italian architecture of today is that the principal client of the architects is the State itself. While this has its drawbacks, it has also unquestionable advantages, since it substitutes for private speculative enterprise a unified nation-wide organization which helps the integration of architecture and city planning as a

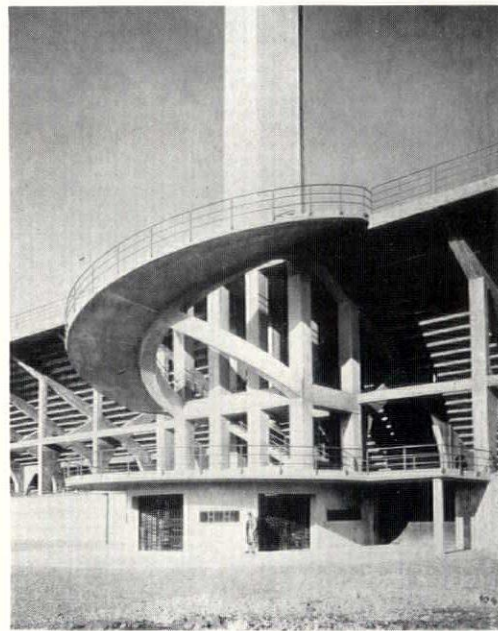

5



FOTOS: ENIT

6



2

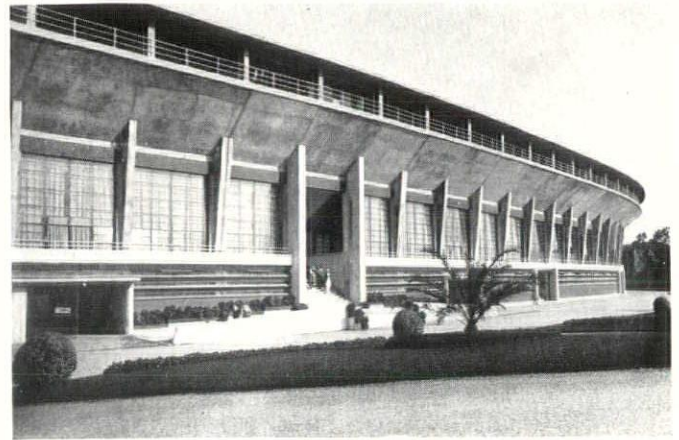

1



3

national art exercised in the interest of public welfare. Also, the State is the natural dictator of architectural style, since it pays for the work. And the State has formally approved modern architecture, and accepted it as its very own.

The decisive battle between the new and old schools of thought was staged over the design of the R. R. Station at Florence. Disputes were many and heated\* particularly among laymen, who found it difficult to appreciate the reasons for so radical a departure in style. The debate reached the Chamber of Deputies and the Senate, where the administration finally put an end to the wrangling. (The building is not finished.)

The government sponsors many architectural competitions for the designs for important works. The outstanding ones of recent years have been the town of Sabaudia, the University Group at Rome, and the Palazzo del Littorio. The latter is to be within a few steps of the Colosseum, and it will be interesting to see how the ancient structure flatters (or flouts) the new.

When Italy does adopt a new style that has originated elsewhere, as in the case of Gothic art, that style does not go through the normal cycle of



FOTOS: ENIT

1. Stadium Mussolini at Turin. . . . 2. Open air balcony, "Carlo Forlanini" Hospital, Rome. . . . 3. Postal and Telegraph Office Building at Sabaudia. . . . 4. An automotive ramp garage, Piazzale Rome, in Venice

4





5

development, peak and decadence; but is moulded and changed to form the basis for further, always indigenous, artistic expressions. Italy does not take new ideas and forms readily, but once they have been accepted, they are absorbed and adopted so deeply that there is no turning back. In other countries, as for example Soviet Russia or Germany, there is already visible a trend away from what we call modern in architecture. This might be considered as indicating that the original acceptance of modernism was more or less superficial—more a conformance to fashion than a realization of changed needs, although imposed restrictions on designers are also factors. In Italy, however, modern thought with its expression in modern architecture, has come to stay. It may be developed, dramatized, built-upon, modified, but it will never be discarded. Modern art is a national art in Italy.

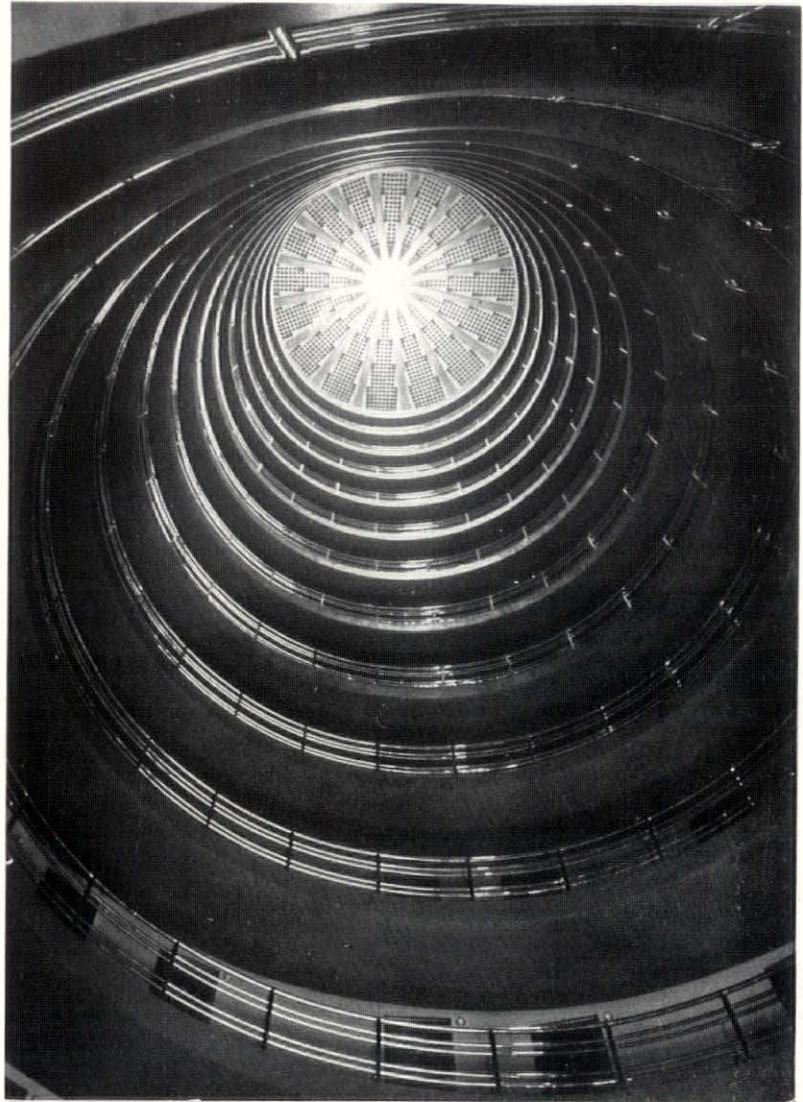

8



6

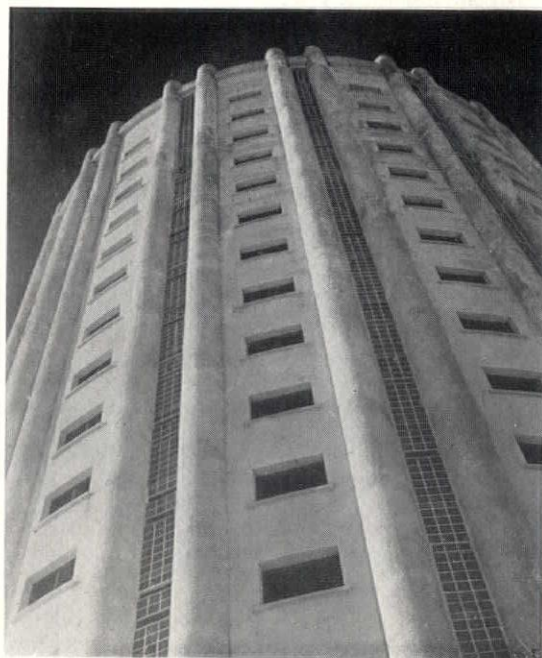

7

FOTOS: ENIT

5. Post Office at Littorio. . . .  
 6. Skylight and spiral ramp in the Hotel Duchi d'Aosto, Sestrieres. . . .  
 7. Exterior of the Hotel Duchi d'Aosto. . . .  
 8. Looking up from lobby of Hotel Duchi d'Aosto through the ramp-enspiraled wall

# "LA VILLE RADIEUSE

becomes the wider horizon of the proponent of "The House, a Machine for Living"

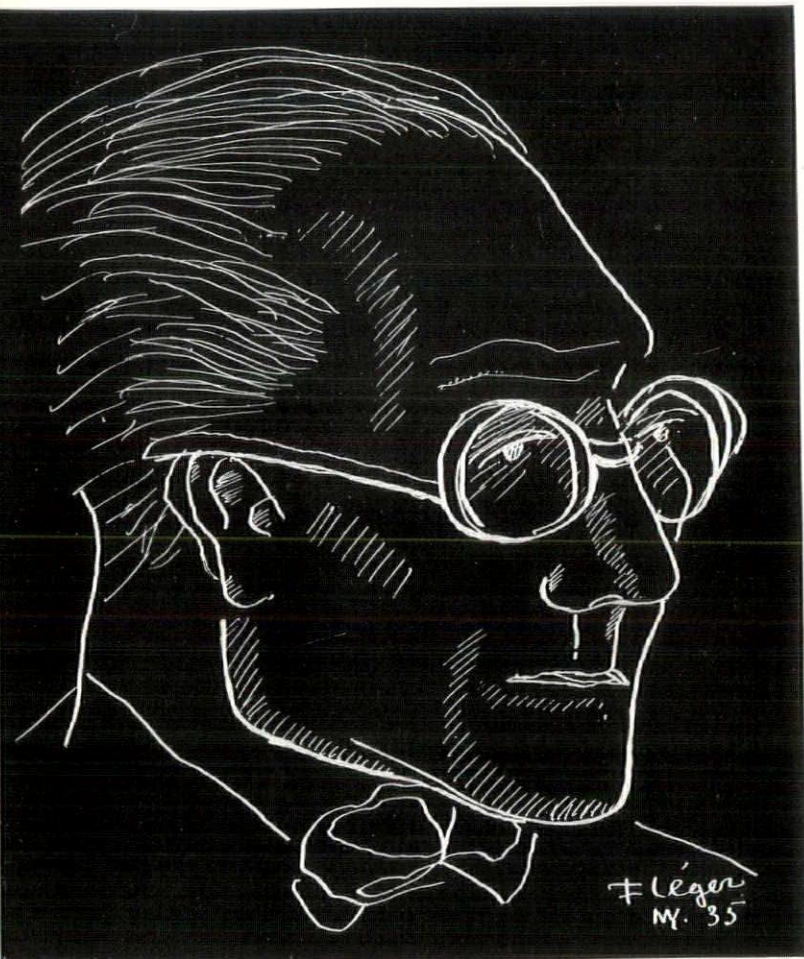

## Le Corbusier\*

visiting this country for the first time, tells America of his visions for its future, its potential "Cities Radiant with Joy"

AS a modest professional man, who has devoted his life to the first cycle of the machine age, it is my mission to present in the field of architecture and city planning a series of proposals which demand, of course, the support of all modern technics, the ultimate goal of which lies far beyond the merely utilitarian. It is indispensable in these days to aim at the goal of giving the men of the machine age the joys of health and of heart.

Such a program is neither specifically European nor American. It is quite simply human and universal. It represents

the urgent job of our time. Let us replace the present brutality, misery and stupidity by what I like to call the essential joys. The last years have chiefly sufficed to make our cities inhuman.

When the *Normandie* stopped at Quarantine, I saw rising in the morning mists a city which was fantastic and almost mystical. There is the temple of the new world, I thought. But as the boat drew nearer to the city the apparition in the mist was transformed into an image of brutality and savagery. This indeed is really the most obvious manifestation

\*Charles-Edouard Jeanneret, Le Corbusier, leading exponent of advanced architectural thinking, now lecturing in the United States under the auspices of The Museum of Modern Art. . . . The sketch portrait was executed especially for *American Architect*, by his good friend, Fernand Léger (distinguished French cubist), whose important paintings were exhibited during October at The Museum of Modern Art

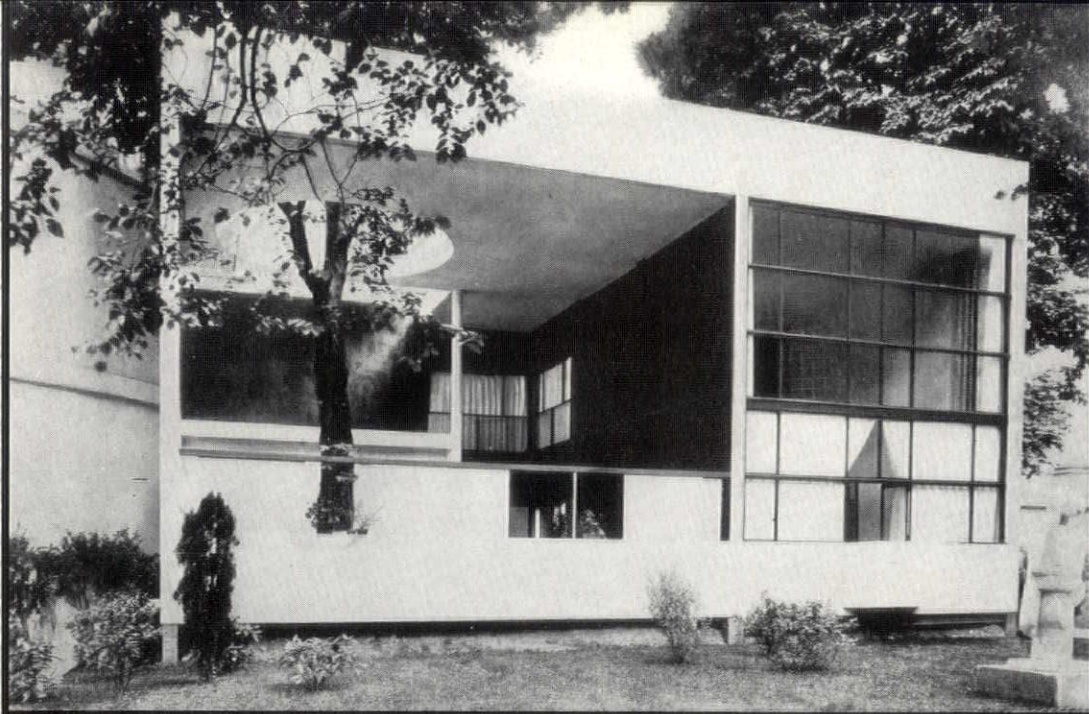

1925

—Pavillon de L'Esprit Nouveau, International Exposition of Decorative Art, 1926.  
LE CORBUSIER, Architect

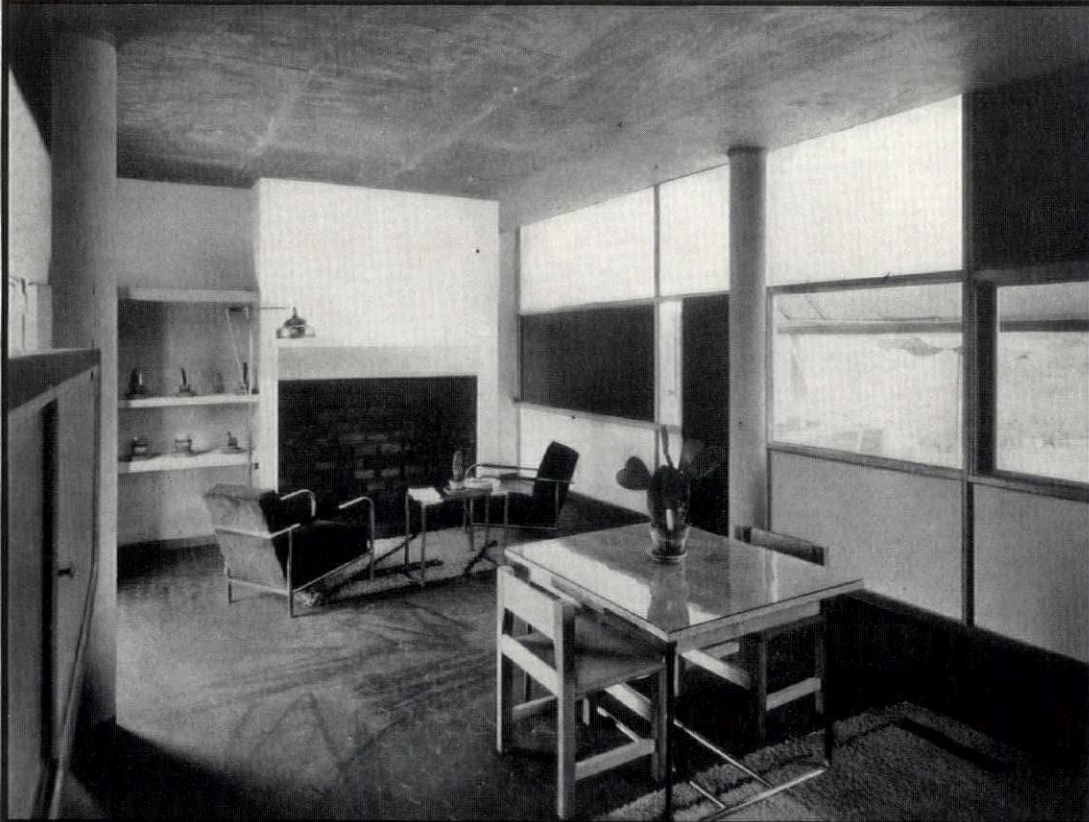

1930

—de Mandrat House, Le Pradet near Hyeres, 1930-31.  
LE CORBUSIER, Architect



1935

—Villa in the eastern outskirts of Paris, 1935.  
LE CORBUSIER, Architect

of modern times. These, brutality and savagery, do not necessarily displease me. For it is thus that all great work must begin—with strength. That evening on the avenues of the city I came to appreciate the American people who have been able, following some law of life which is their own, to create a race—a race of splendid men and beautiful women.

The world at present is undergoing one of the great changes of history. Collective interest and individualism are at logger-heads instead of co-operating. Is co-operation possible? Yes, through a program human in scale and of a human breadth of vision. The time has come for great architecture. And there can be no new architecture without a new urbanism—that is, new principles of planning cities. New cities have always in the course of time replaced old ones. Today, at last, a new type of city can be born, the city of our modern times, filled with happiness, radiant with the essential joys.

Academic architecture has had its day. Architecture has a new purpose which is the re-arrangement and co-ordination of all the developments of today. Let us talk no more

of style, whether modern or traditional. Style is the thing itself—to paraphrase a famous French saying: architectural style is no more than the society of the machine age as manifested in its thought, its methods of production, its general equipment, and hence in its dwellings and cities.

America, which perpetually evolves, which has infinite material resources, which has potentials of energy unknown elsewhere, is the very country most capable of realizing first and with extraordinary perfection this great task of our day.

I have a profound feeling that the ideas I bring with me and which I am presenting under the slogan of "La Ville Radieuse," "The City Radiant with Joy," will find in this country their natural soil. Coming here to explain this basic doctrine of the equipment of the machine civilization, this constructive thesis, which is optimistic and active, I realize the boldness of my hopes, but I am full of faith in the power of our modern age, and I am certain that I shall meet here many whose experience and judgment have led them to hold similar high hopes.

THE architectural revolution made possible by modern technical methods provides the solution for the problems of city dwelling in a mechanistic age.

A hundred years of technical improvement have opened little by little the road to modern architecture. A new architecture has been born, breaking with tradition and offering to the living generation a new kind of dwelling. This new type of residence is efficient and economical; it is rational and functional; it responds to the profound aspirations of the modern conscience and expresses a new era of civilization.

At the same time we are now faced with the problem of city dwelling. As a matter of fact, city dwelling and architecture have become one and the same thing.

Until now, living in cities has been a science of two dimensions. Today the solution of the problem of city dwelling can be solved only by some three-dimensional scheme.

The studies to which I have devoted my life are only one technical manifestation. The object of these studies is the body and the soul of mankind; it is biological and psychological. The period of blind egoisms has passed. The whole social phenomenon has now to be considered, the needs of the

individual as well as of the group must be studied. This is the new equation which we are forced to accept.

Solid as a rock is my belief that city life should hold as sacred the right of the individual to his personal liberty, liberty regulated by social order in opposition to chaos which destroys the individual and society also, a chaos that promotes greed which in its turn completely wrecks the social fabric.

Insistent effort is needed to arrive at solutions that are radical, sane and fair, with a due regard for human values.

The great revolutionary cycle of a mechanistic civilization, after a one-hundred year era consecrated to prodigious discoveries, should add to the world's happiness, to wit, architecture and city dwelling.

I am particularly happy to be able to express my ideas in this country which, in a blinding glory, has conquered the first steps toward the achievement of complete mechanization. We find here assembled means for this achievement, the youth and the background from which should emerge this crystallized truth of a new world. America will be proud and fearless in demolishing the false and reconstructing in her enlightenment a saner, stronger and better world.

Commissariat of Light Industry, Moscow, U.S.S.R., begun 1931, (photo September, 1935, by Ehrlich). Le Corbusier, Architect

Model of a project for Palace of the Soviets. 1931-1932. Le Corbusier, Architect

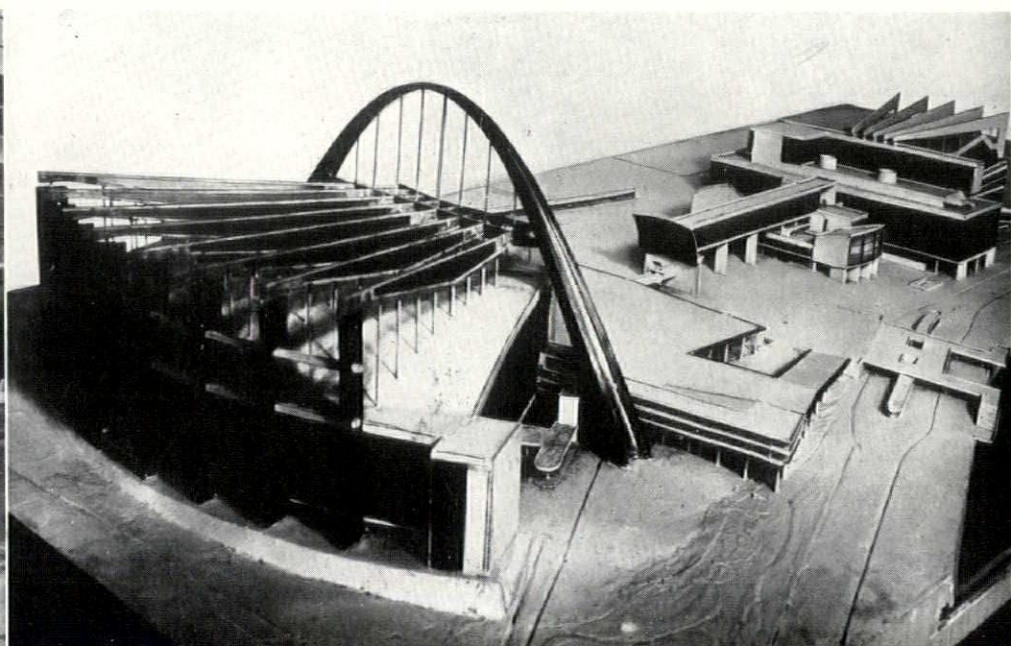



PHOTOS: SAMUEL H. GOTTSCHO

RICHARD SALTER STORRS LIBRARY  
LONGMEADOW, MASSACHUSETTS  
SMITH & BASSETTE, ARCHITECTS



RICHARD SALTER STORRS LIBRARY

SMITH & BASSETTE, ARCHITECTS

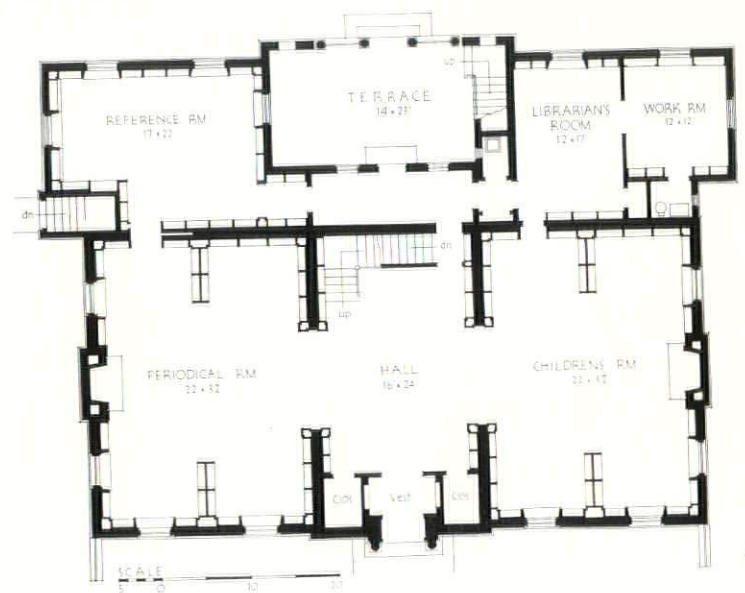
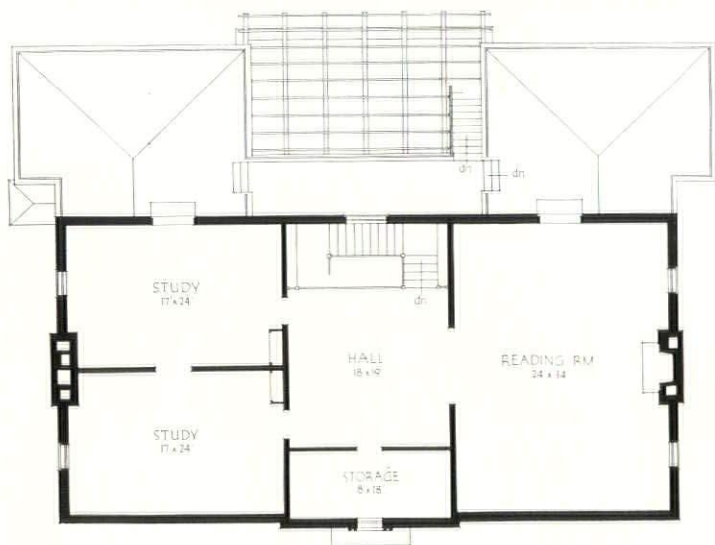

RICHARD SALTER STORRS LIBRARY  
LONGMEADOW, MASSACHUSETTS  
SMITH & BASSETTE, ARCHITECTS

The domestic character of the design of this library, which serves a town of five thousand inhabitants, is most appropriate, interpreting as it does something of the neighborly spirit of the people in the community. . . The walls are of brick painted white; the swag panels, white marble; wrought and cast-iron railing at terrace; roof, black slate; shutters, green; entrance motif and cartouche, wood. The children's room with all furniture at reduced scale is seen at the right. . . Below, the building from the rear. From the second floor rooms French doors open onto a roof deck from which a stairway leads to the ground level terrace. The deck railing is wrought iron



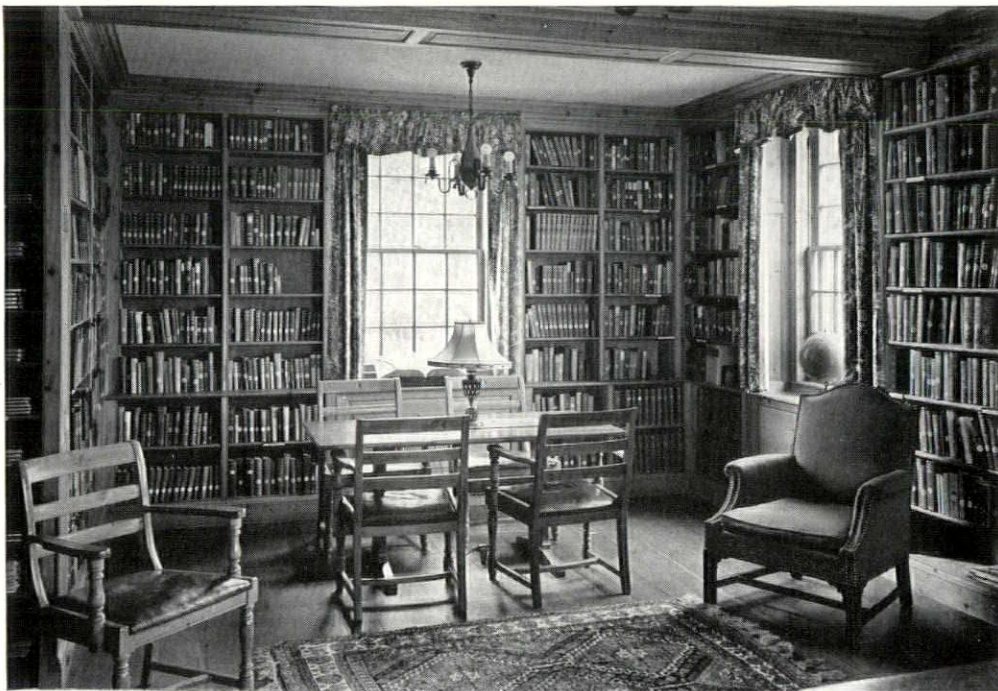

The quiet grace of the exterior of the Richard Salter Storrs Library has been thoughtfully carried out in the details of the interior. . . Above, looking through entrance hall toward periodical room. The woodwork and walls are painted a soft green; draperies, dull yellow damask; furniture colonial reproductions in cherry, maple and mahogany; floors, wide oak board stained dark brown. . . At left, the reference room. All woodwork is of white pine with stained wax finish; furniture, maple, upholstered in red leather; floor, wide oak board



# A PRIZE WINNING MODERNIZATION



PHOTOS: SAMUEL H. GOTTSCHO



THE PRIZE WINNING MODERNIZED HOUSE OF DONN JEFFERSON SHEETS, ARCHITECT

FOR this mid-Eighteenth Century Connecticut farmhouse, restored and modernized, the architect was awarded the first prize of \$1,000 in the recent "Good Housekeeping" modernization and remodeling competition. Although dilapidated, the old house was of sturdy construction. The restoration consisted mainly of re-framing in places with chestnut and oak 4" x 4" taken from the old barn and some new 2" x 4". On the exterior, defective clapboards were replaced with red cedar siding over sheathing and weather-proof paper, and all exterior walls filled with rock wool insulation. In part of the living room and main bedroom, hand troweled plaster was put on over metal lath, with cement plaster used on the inside of the porch. All other walls

were covered with gypsum insulation board. The wide oak board floors were taken up and relaid over subfloor and paper, and linoleum was used for kitchen and bathrooms. The old stone chimney was demolished and rebuilt and one other constructed. A concrete foundation was poured for the living room and under the kitchen addition. A stone wall was laid under garage and shop. The lower part and ceiling of living room were paneled with old wide chestnut with batten strips at joints. The fireplace side of master bedroom was covered with old pine raised panels. In kitchen new white pine matched boards were used. Brass pipe was installed throughout. The heating system is two-pipe vapor steam, and the electrical work is BX cable with heavy lines.



## CONSTRUCTION COST DATA

Framing—New materials .....	\$829.00
Masonry—Materials and labor .....	609.30
Plumbing—Materials and labor .....	476.67
Heating—Materials and labor .....	488.35
Carpenters and laborers .....	1,017.39
Plaster—Materials and labor .....	100.00
Insulation wall board .....	220.00
Linoleum .....	50.00
Electric work—Materials and labor .....	230.00
Paint—Materials .....	75.00
Rock wool insulation .....	115.00
Hardware .....	50.00
<b>Total .....</b>	<b>\$4,260.71</b>

Architect's own work finishing house figured  
on basis of other workmen—Architect owner  
on job constantly..... 700.00

**Grand total .....** **\$4,960.71**

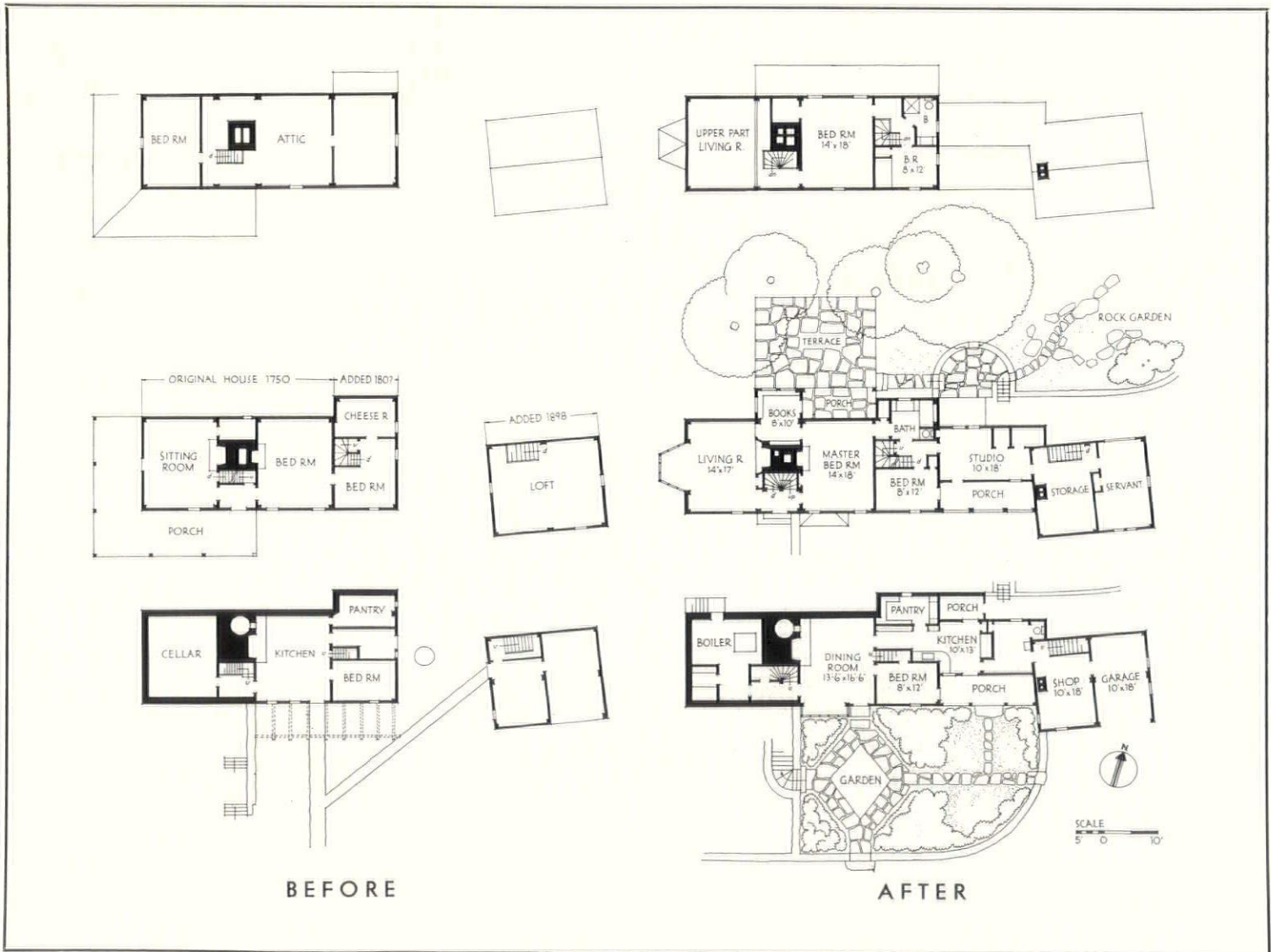





This dining room was originally the kitchen of the old house. The paneling around fireplace, the wainscot and trim are old pine, reproducing existing mouldings in the house. The pine cupboards hide wall radiators. The floor, of old wide oak boards, and the ceiling beams are waxed in natural colors. Walls and ceilings, of wallboard covered with canvas, are white; but the soft old reds and yellows in the antique rug are repeated in the old bricks, the sumac red wainscot, and the antique yellow paneling and doors. Donn Jefferson Sheets, architect



A ruddy orange-brown brick was used for the exterior with lighter and darker shades, in combination with black brick, for the pattern spandrels and horizontal bands. The terra cotta sills, copings and ornamented band courses in the upper stories, are the same color as the brick

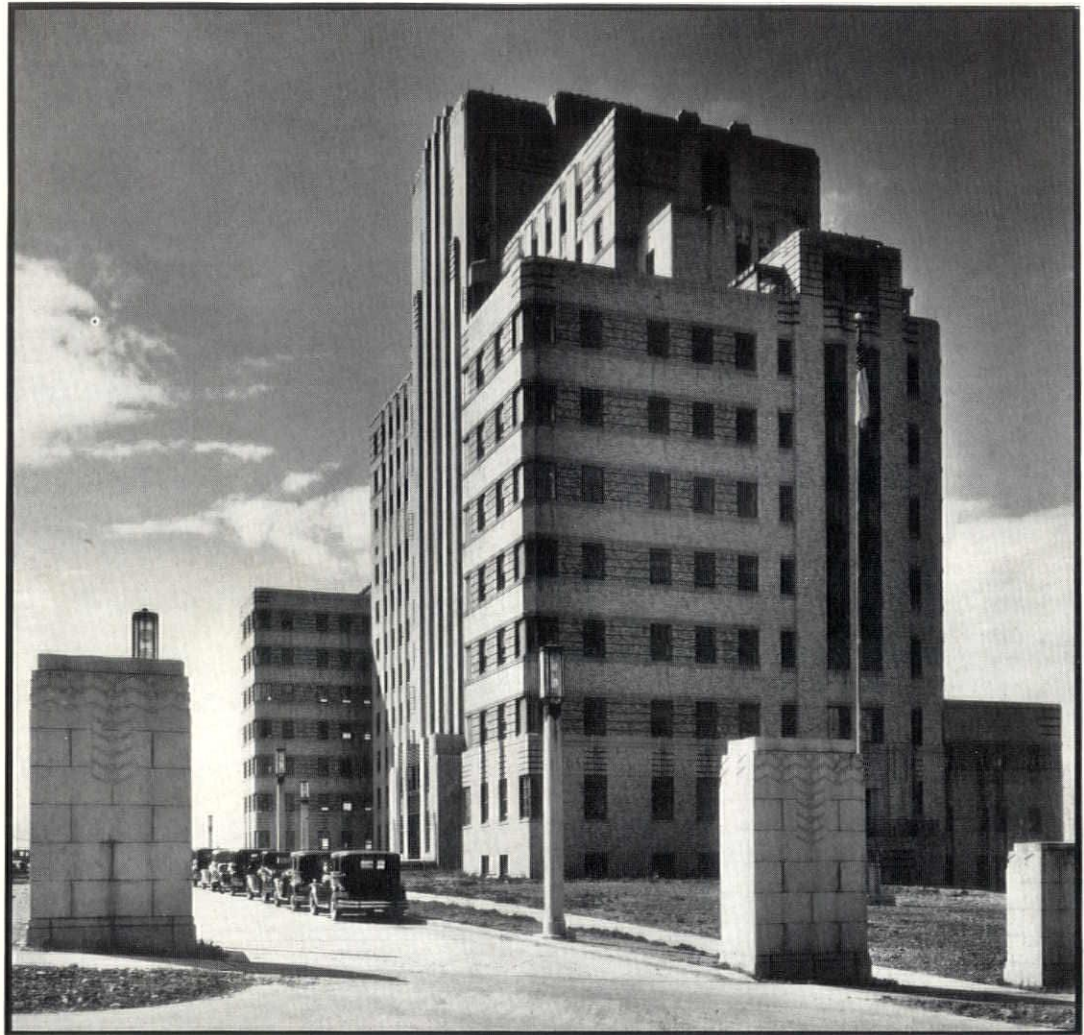

PHOTOS: H. C. DAVIDSON

## U. S. MARINE HOSPITAL, SEATTLE, WASH.

BEBB & GOULD and JOHN GRAHAM, Associate Architects

**SPECIAL PURPOSE.** A general hospital exclusively for men, largely gregarious, many "ambulatory," moving about without assistance. Therefore, typical floor plan has large wards and a smoking room solarium at one end of each 14-bed ward. Also, for this reason, there is a large recreation room on the second floor with library adjoining; the cafeteria adjoining the kitchen on the ground floor, and dining rooms adjacent to diet kitchen on each floor. Likewise, the doctor's office, treatment room and patients' locker rooms were placed on each floor.

**SITE AND ORIENTATION.** Irregular, sloping, about  $9\frac{1}{2}$  acres. Approach from north, but main entrance placed on south; reasons,—(1) it allowed well-lighted and ventilated kitchens, dining rooms, laundry, general storage, ambulance

entrance, boiler rooms, garages, etc., below main entrance floor, but accessible at grade; (2) traffic approaches on the easy grade, keeping at right; segregating main entrance traffic from service; (3) the psychological value of placing the entrance, reception rooms, examination rooms and executive suite on the sunny south side. The main hospital building is near the center of the property, isolated from street noises.

**WHY SKYSCRAPER?** For economies including centralization of food, laundry, supply service; and simplification of heating, ventilating, plumbing and wiring. The patients' rooms are well above the ground level and by limiting beds to forty-five to fifty-five per floor, they always receive ample sunlight. Elevators, dumbwaiters and principal service stairs are centered, and close to utilities and kitchens.



The Entrance Lobby

**TYPICAL FLOORS.** Each provides for three nurses' units for 14 to 20 patients. One nurses' station is at center and one is at either end for each of the 14-bed wards.

**CAPACITY AND GROWTH.** Normal 324 beds. With beds in smoking rooms, 48 additional patients possible. Program called for future addition of 70 to 80 beds. A vertical addition deemed preferable to a wing. Solution: Placing nurses quarters on the 10th, 11th and 12th floors of the main build-

ing, later to construct a separate nurses' home, remodel the present upper floors for hospital use. The plumbing for this change was roughed in, and wiring provided in the slabs.

**STRUCTURE.** Main building and attendants' quarters buildings are reinforced concrete.

**HEATING.** Steam is generated at 100 lb. gauge pressure in three 150 lb. double-pass fire-tube boilers. High pressure steam at 60 lb. is run to the 6 ft. pipe-attic below 9th floor, thence to sterilizers. Low pressure steam is obtained through five sets of pressure reducing valves which are located in a separate room lined with sound absorbing cork. The building is divided into five zones for heating, each zone being controlled by a graduated action pneumatic-diaphragm valve in the pipe attic, with manual control cut-out switches in the engineer's room in the basement. Most radiators are tubular cast-iron, on wall hangers; concealed copper-type radiators in entrance vestibule and main lobby.

**VENTILATING.** Forced only in ninth floor operating suite and the kitchen and dining rooms on the ground floor. The former has a 5500 c.f.m. system: supply and exhaust fans, air washer, filter, heating coils, pneumatic automatic temperature and humidity control; and the latter by a similar system with a capacity of 1900 c.f.m. The automatic humidity control is used to prevent explosions of ether due to sparks from static electricity in operating rooms. Control is set to maintain a dew point of 62 degrees at the discharge end of the washer. This gives relative humidity of 65 per cent at a room temperature of 75 F., so high that no danger from static electricity exists.

A central control system for all fan motors on one control board is in the engineer's office, having start and stop push buttons and pilot lights for each motor.

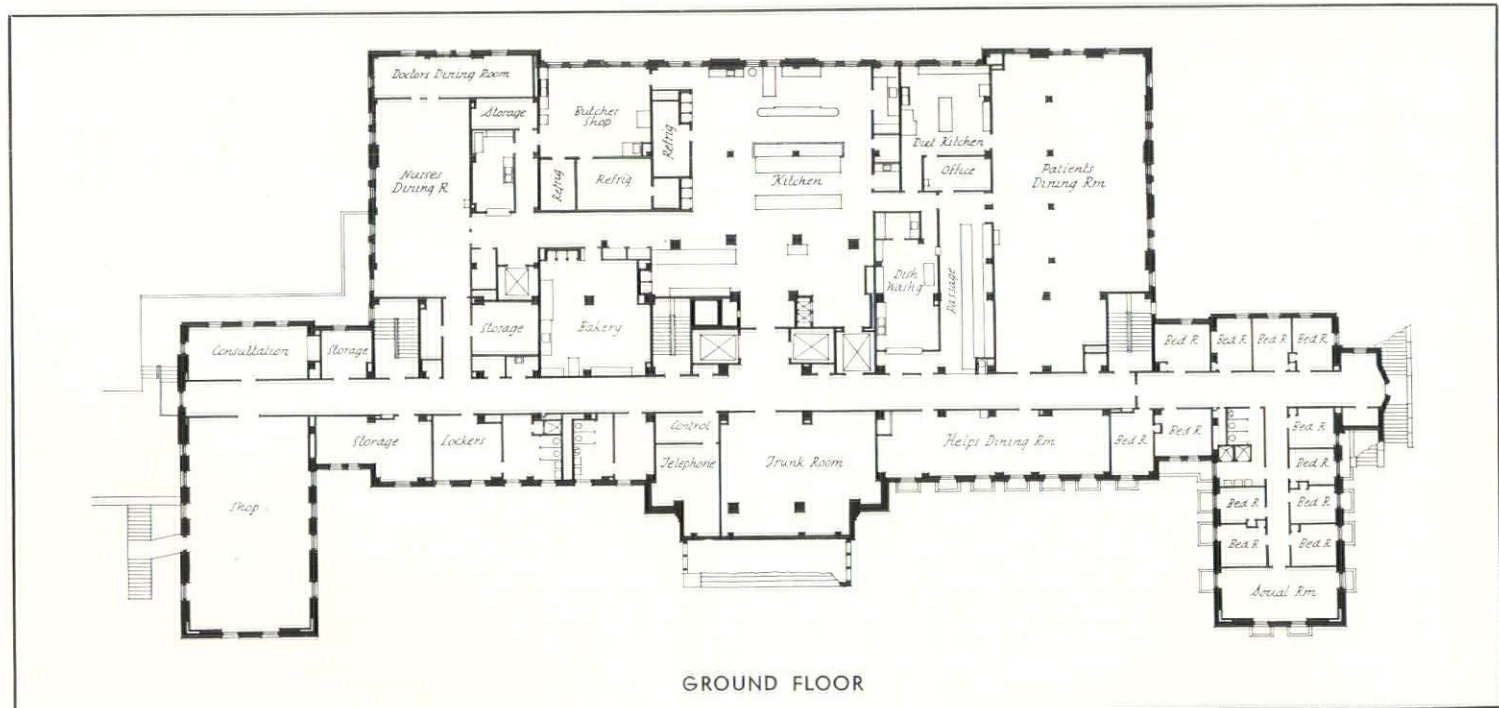

GROUND FLOOR



11. p. Seattle  
11. 5. 11

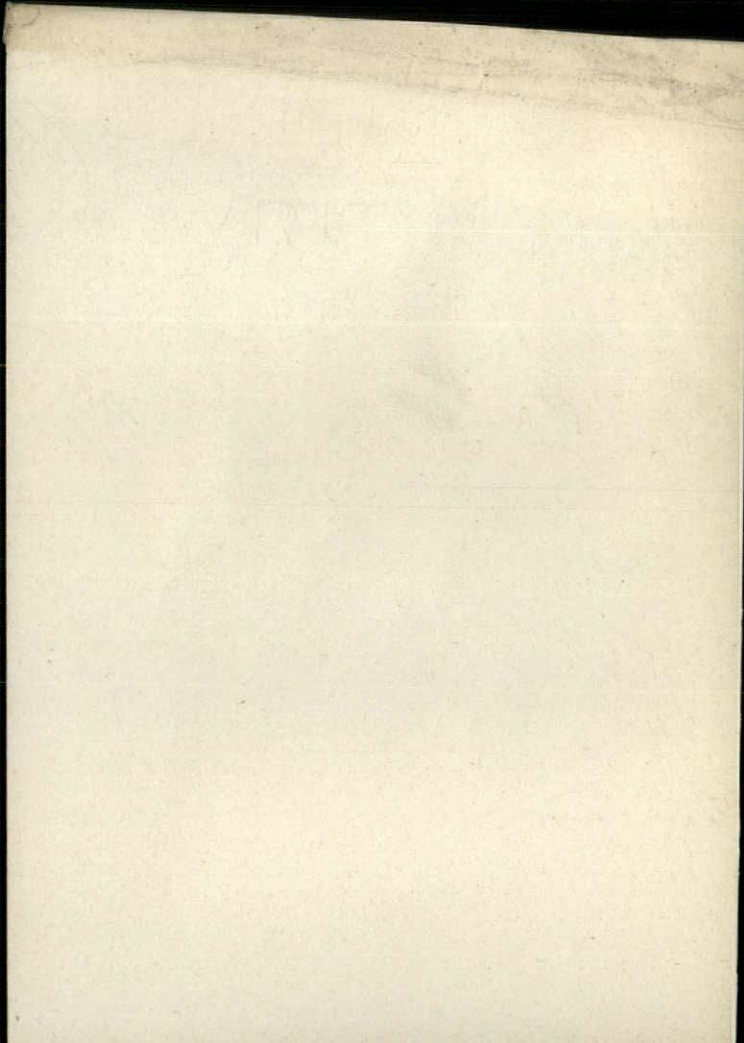



U. S. MARINE HOSPITAL, SEATTLE, WASH.

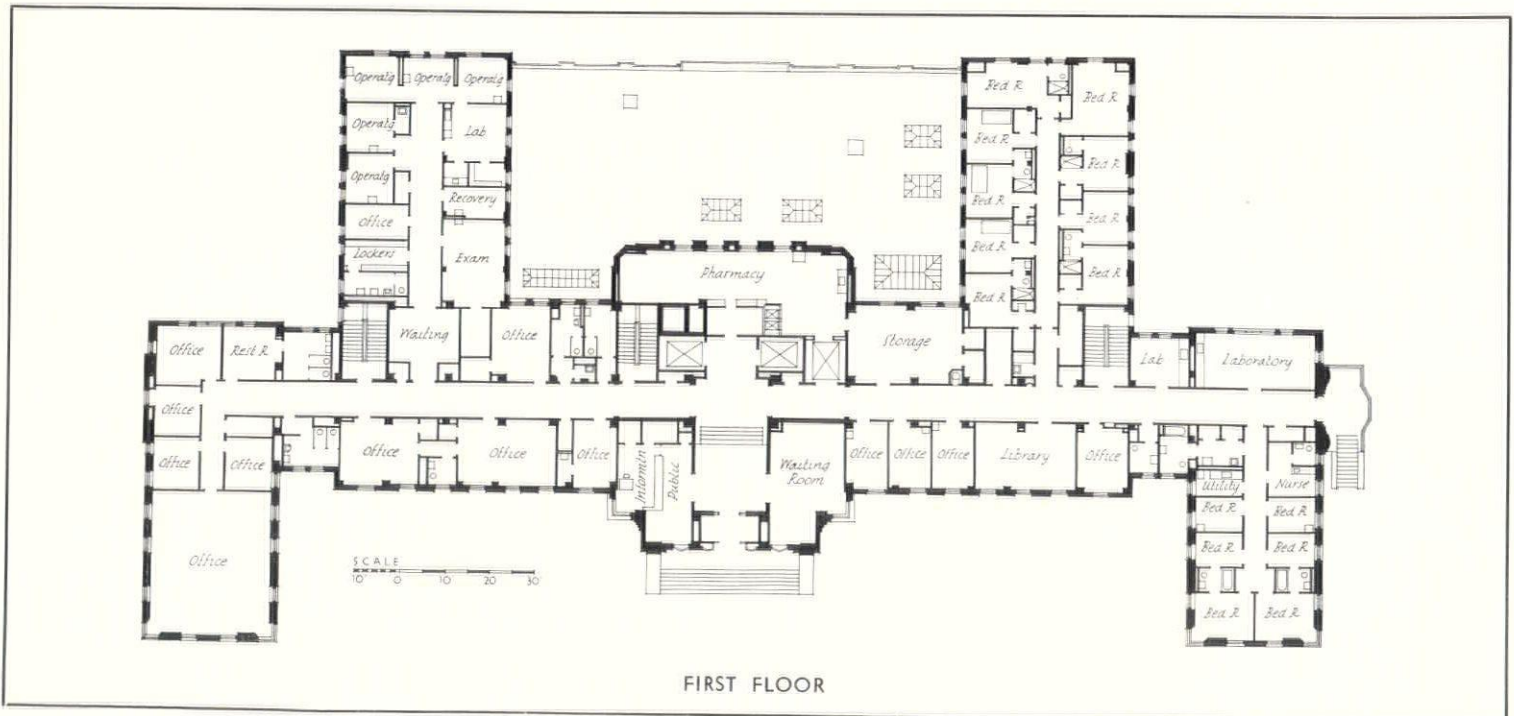

The operating rooms, on the ninth floor, as shown at right, are equipped with automatic humidity control. The apparatus is set to maintain a dew point of 62 degrees at the discharge end of the washer. This gives a relative humidity of 65 per cent at a room temperature of 75 degrees which is so high that no danger from static electricity and consequent ether explosion exists. . . . Below, is the sterilizing and wash-up room between the operating suites

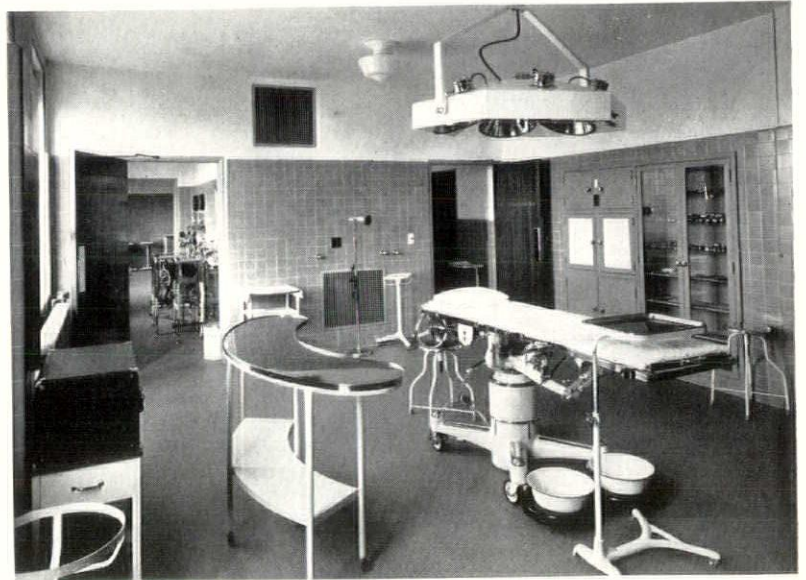

**PLUMBING.** Grade A fixtures are used throughout. All waste and soil lines in accessible pipe shafts. Hot water generated in two 1,500-gal. tanks, hourly capacity 400 gal. 180 F. Waste for sterilizers has open funnels preventing contamination by back pressure or vacuum.

**ELECTRICAL.** For lighting, three 150 kw. transformers. Power service for motor, three 100 kw. transformers. One 75 kw. transformer for X-Ray equipment.

Indirect fixtures for general lighting throughout; reading lamps over beds. Emergency lighting system of storage batteries automatically furnishes light for operating rooms and exits if main supply fails.

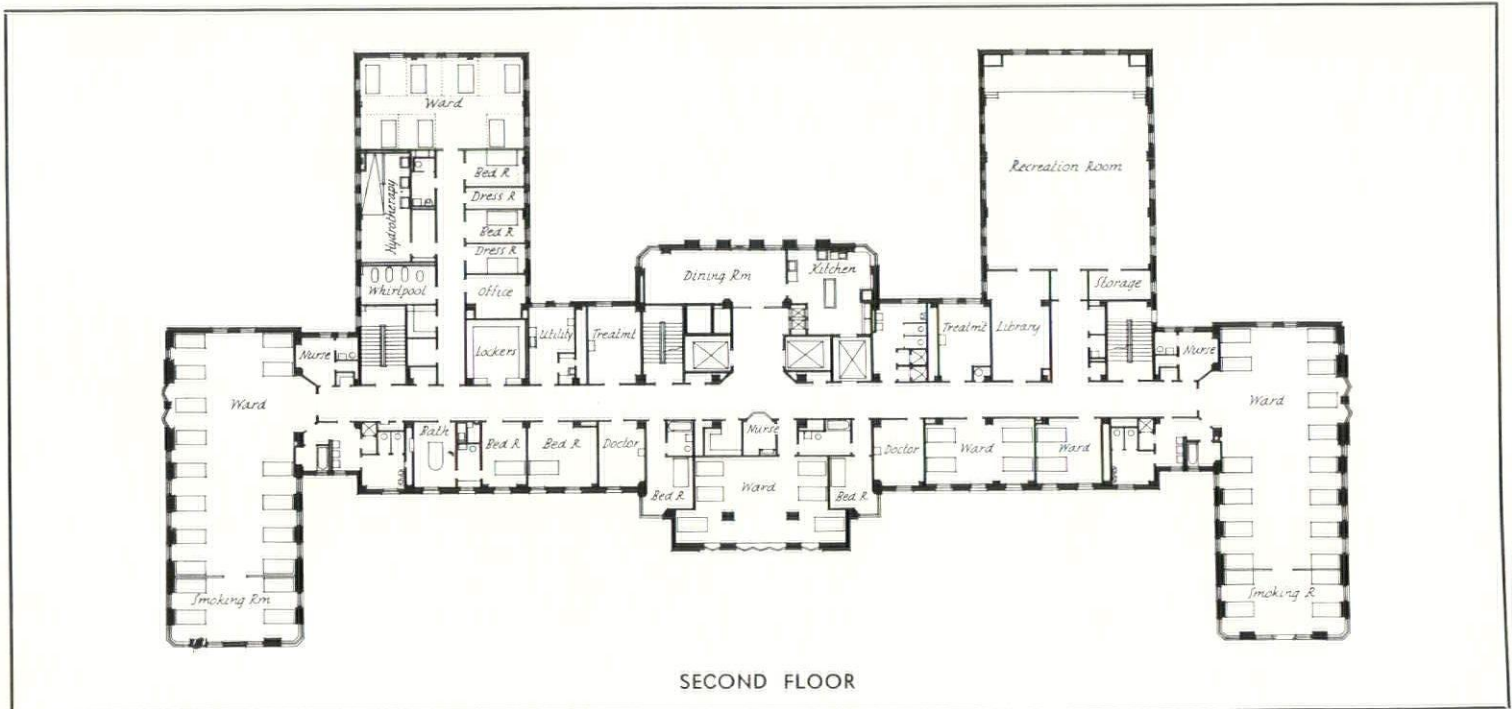

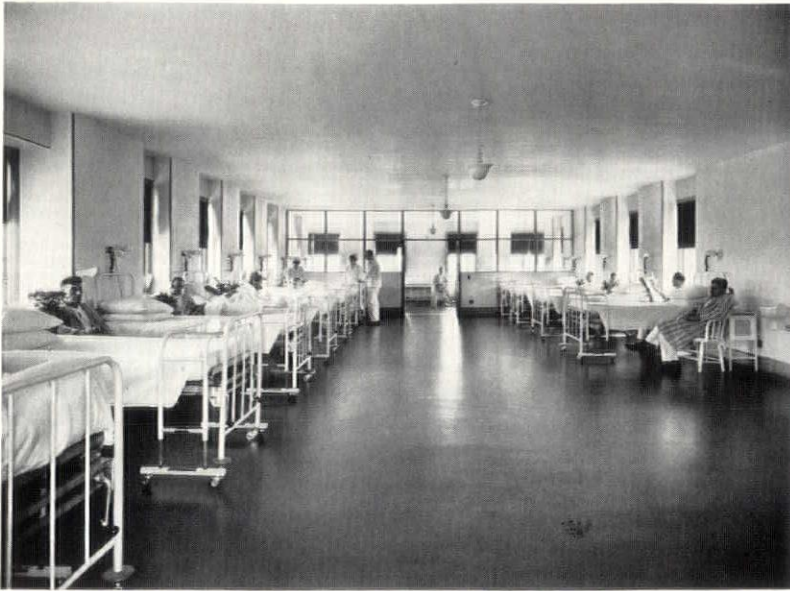

A typical ward, as shown on the second floor plan, is seen at the left. These wards accommodate 14 beds, with a smoking room adjoining, which may be used in case of an emergency to take care of 4 extra beds. In one wing on the second floor is the large recreation room with library adjoining for the convenience of the patients, a large percentage of whom are "ambulatory," able to move about at will. . . . Below, is the hydrotherapy room

**REFRIGERATION.** Central brine circulating plant, duplicate compressors for refrigeration for kitchen, cold storage, ice-making and mortuary.

**MINOR BUILDINGS:** Group includes at present an Attendants' Building for 40 employees other than nurses; a nine-room residence for the officer in charge; and four double residences, each providing two six-room apartments, for resident members of the administrative and medical staff.

**COST.** Contracts for group complete, including architects' fees, approximately \$1,400,000. Main building, approximately \$1,175,000, or 47.7 cents per cubic foot, or \$2,500 per bed.

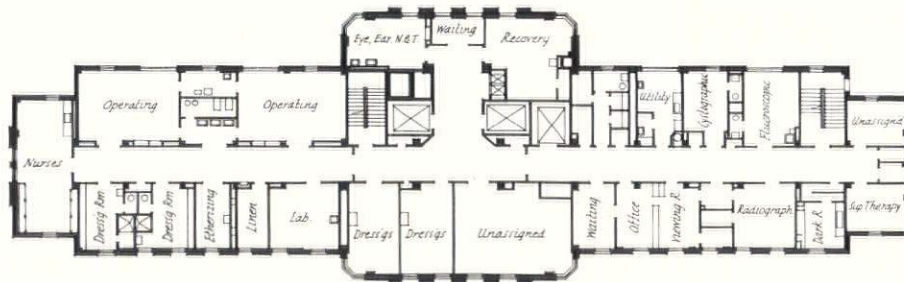

NINTH FLOOR

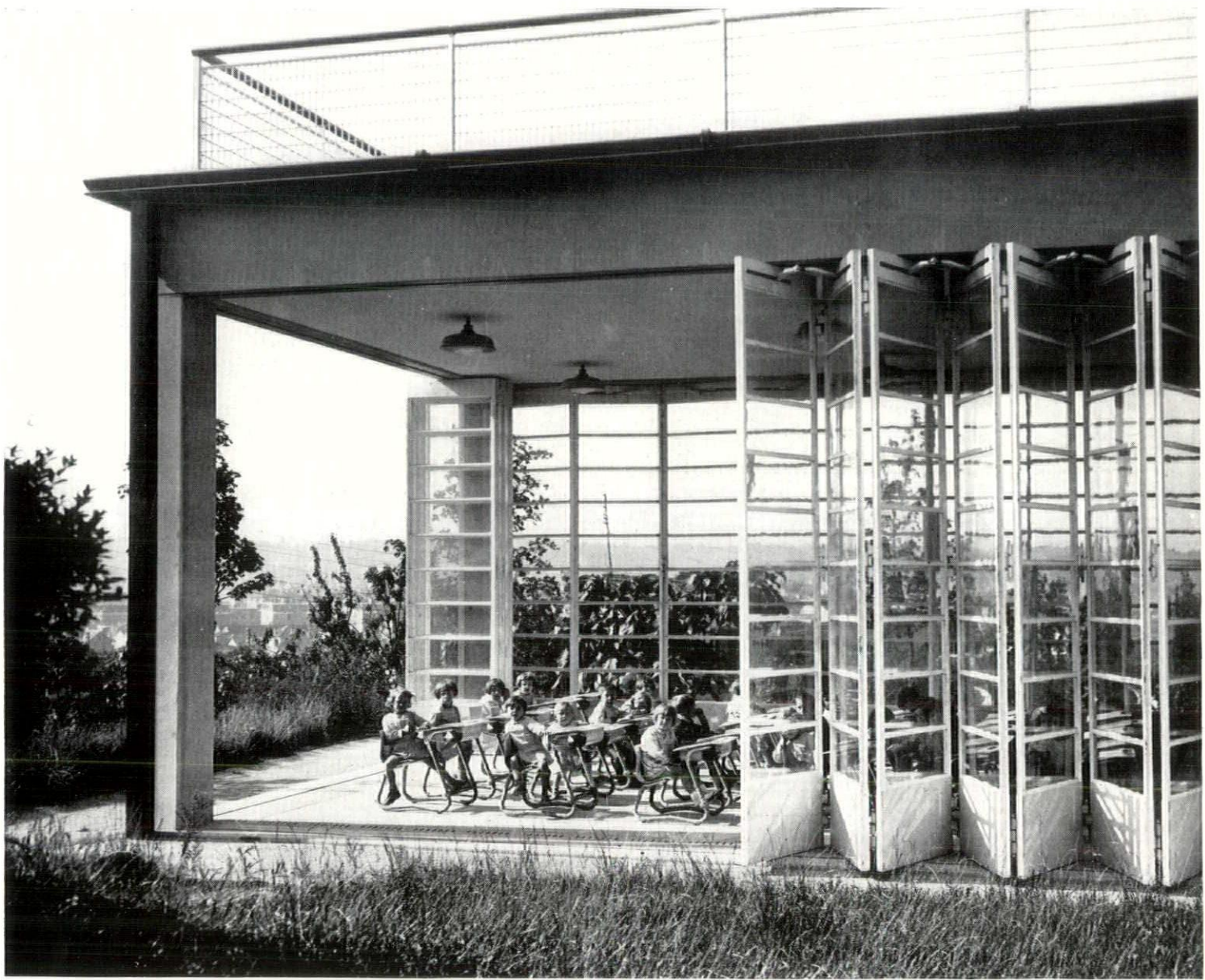

PHOTOS: WIDE WORLD

## THE FRESH AIR SCHOOL, SURESNES, FRANCE

EUGÈNE BEAUDOUIN AND MARCEL LODS, ARCHITECTS

### PURPOSE

Fresh air and sunshine are absolutely necessary to the health of many delicate children, and the more they get of each the better. Therefore, to provide the utmost fresh air and sun at all times and for all the activities of 144 children is the purpose of this school. It provides open but protected and

controlled space for their study and play, their games and crafts, their luncheon and rest.

### SITE

The plot, wooded with fruit trees, slopes to the east on Mont Valerien, Suresnes, near Paris. For protection the two-story solid wall of the main building spreads itself at the north.



Looking toward the girls' two-story wing of the main building from the wooded central courtyard. The ramp which connects the dormitory floor with the roofs of the classrooms forms the roof of the connecting passages of the ground floor. A maximum of light and air is provided by the straightforward functional architecture which gains dignity through its very simplicity

## PLAN

Eight separate three-exposed classrooms are joined by open galleries leading from the main large building. The two long galleries meet at the far end in the medical office. The roofs of the classrooms are used as solarium when weather permits. Ramps are provided instead of stairs, as they conserve the children's energy. Classes are also held in the open, but in hedged areas adjacent to the classrooms.

The long main building is divided into three parts; center, administration and mothers' portion; left, girls' wing; right, boys' wing. Each wing provides coatrooms, lavatories, toilets and showers; a large multi-purpose area, called the "covered courtyard, and a manual training room at the extremity. The floor above is the dormitory for rest and for the siesta, compulsory after the mid-day meal.

## CONSTRUCTION

In general, steel skeleton frame, with concrete for fixed walls; movable walls are of glass, in steel frames. Glazed walls are *sliding* for the covered courtyard; *accordion-folding* for classrooms; and *descending* for baby pavilion. Exposed metalwork is painted clear blue. Floors are tiled. Roofing, sheet metal, insulated.

## SHOWERS

Large shallow basin, rather than individual stalls, and a rain of warm water from many shower heads in the ceiling.

## HEATING

Classroom floor is entirely heated by steam to 85 to 95 F. centrally controlled, supplemented by a "curtain" of forced, fresh, warm air from channel tubes surrounding the classroom floor and controlled by the teacher.

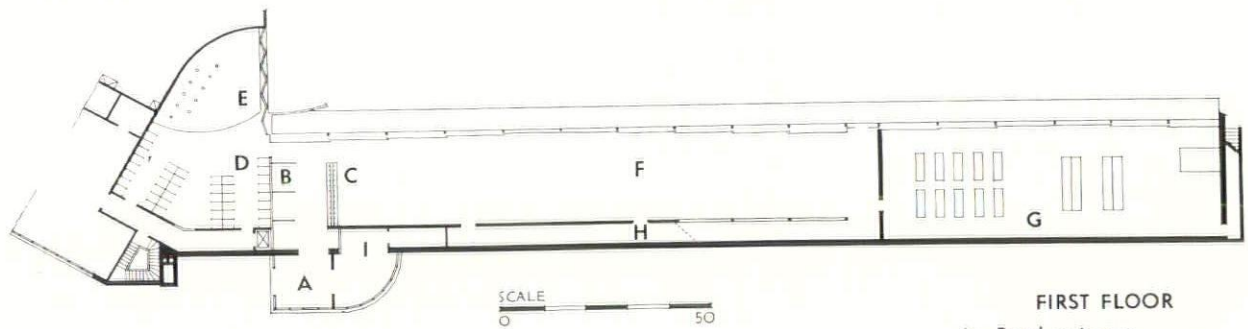
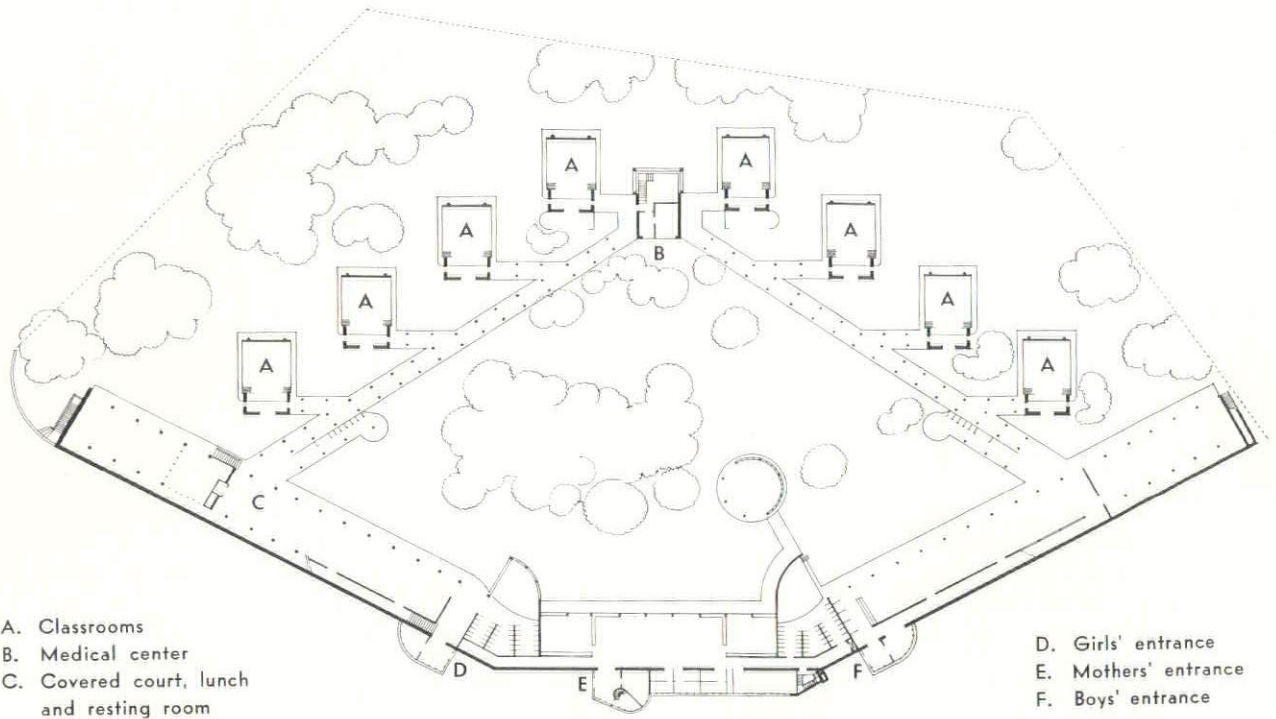

FIRST FLOOR

- A. Boys' entrance
- B. Cloakrooms
- C. Lavatories
- D. Dressing rooms
- E. Showers
- F. Boys' covered courtyard
- G. Practical work
- H. Storeroom
- I. Parlor

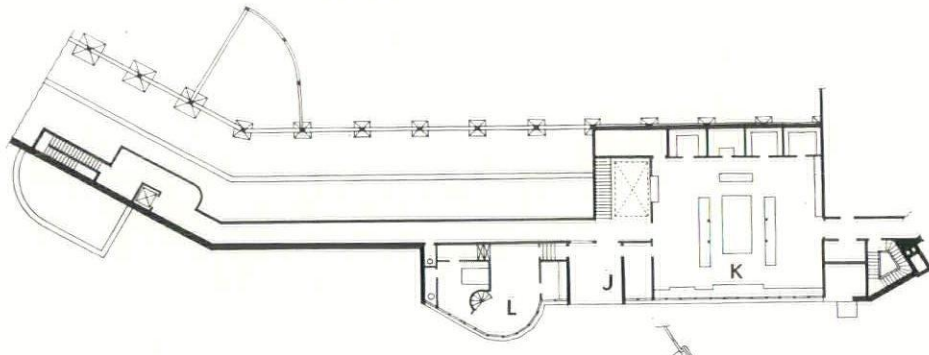

SECOND FLOOR

- J. Porch
- K. Kitchen
- L. Janitor

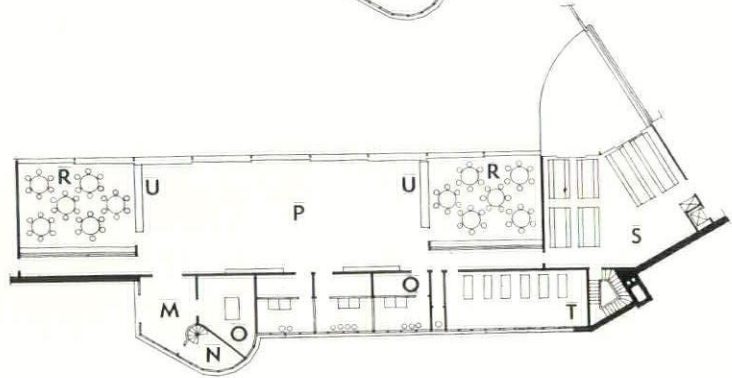

THIRD FLOOR

- M. Entrance
- N. Janitor's place
- O. Office
- P. Mothers' "courtyard"
- Q. Cloakrooms, lavatories
- R. Classrooms
- S. Mothers' dining room
- T. Artificial beach
- U. Animals





The classroom roofs are used as solarium when weather permits and are connected by the ramps (shown above) with the second floor dormitory wings in the main building

The classrooms are spaced for a maximum of sunlight and air. They have accordion-folding glass walls on three sides and a solid wall for the teacher's platform, desk and blackboards on the fourth side. A door leads to the coatroom, lavatory and toilet

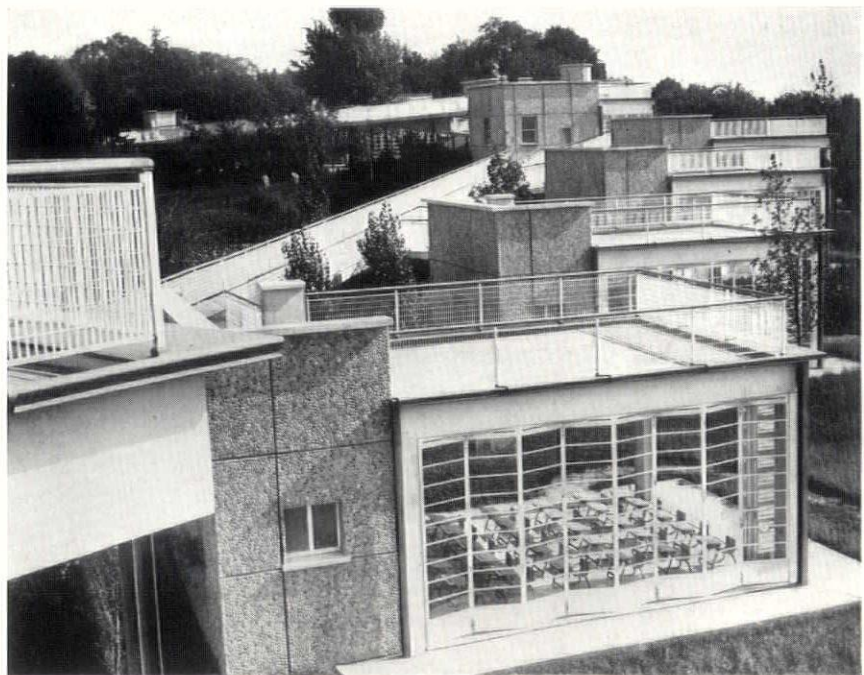
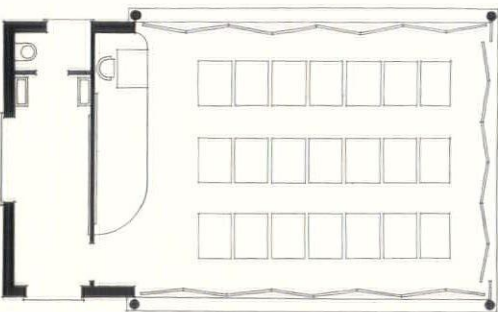

A maximum amount of sunlight on the South is provided by the band of windows running the full length of the central portion of the building



PHOTOS: PEYSER & PATZIG

# THE OPEN AIR SCHOOL

NEWARK, N. J.

JOHN T. SIMPSON & BROWN ROLSTON, ARCHITECTS

THIS SCHOOL was planned to care for tubercular inclined children, culled from the public schools of Newark. The design problem was therefore both one of education and a modified form of hospitalization. To provide ample sunlight and air in classrooms, without stringing the building out in one long succession of rooms on the South side, was a difficult task. This was accomplished by placing the four classrooms on the South side, putting in an airing balcony on the North, and lowering the ceiling of the dividing corridor to 8 feet. A sawtooth skylight facing the South was installed, and another was placed facing the North to nullify the darkening effect of the roof. The sides of the airing gallery were left open, but were so constructed that sash might be installed later if found necessary. A playroom was provided on the first floor for recreation and the airing gallery serves as a place for periodical rest periods. The stairs were made with very low rises and broad treads, which are easy to ascend without overtaxing the strength of the pupils.

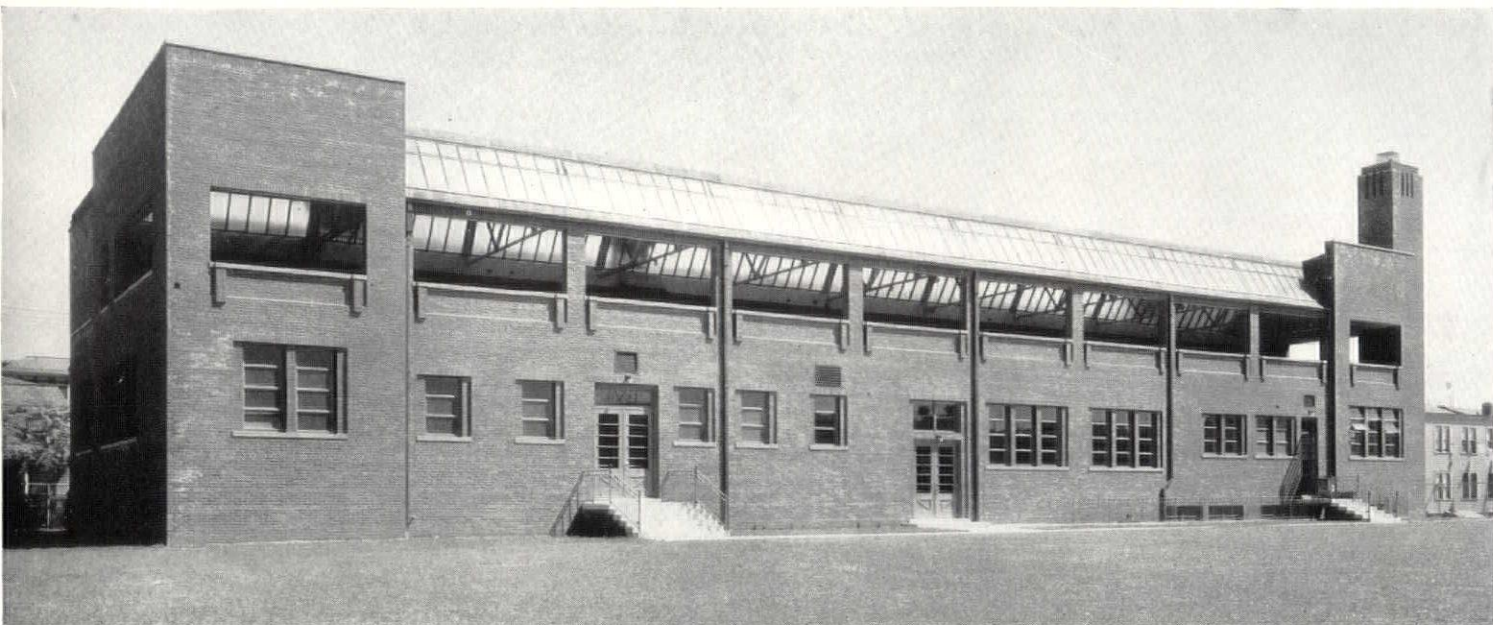

THE OPEN AIR SCHOOL, NEWARK, N. J.

JOHN T. SIMPSON & BROWN ROLSTON, ARCHITECTS

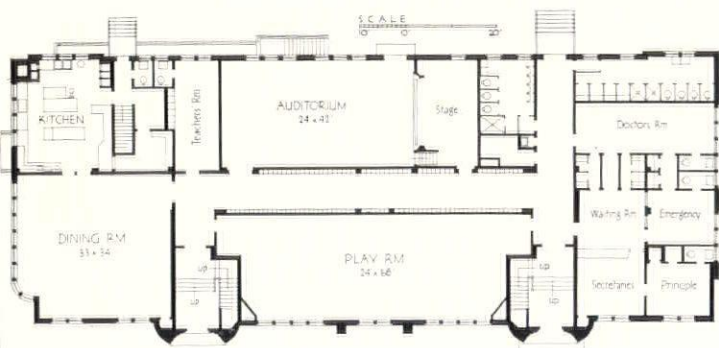

First Floor Plan

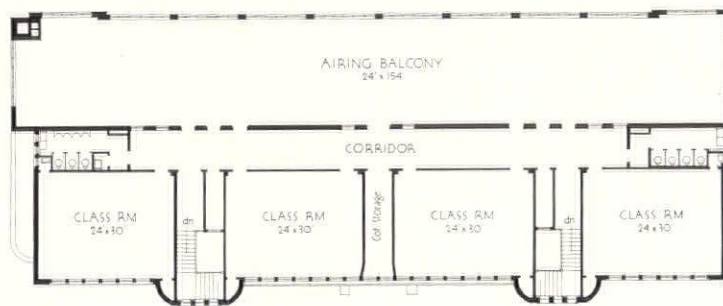

Second Floor Plan



# UTILIZATION vs. EXPLOITATION

BY LOUIS K. COMSTOCK\*

THE present depression, . . . has laid bare certain fundamental weaknesses in the method of land utilization which call loudly for correction.

Some of these weaknesses have been matters of common knowledge for years, but others have made themselves apparent only within the last half decade. These weaknesses which have been recognized for years have not been corrected perhaps because the real estate industry has lacked effective organization and the necessary collective vigor to combat unrestricted selfishness on the part of the owners, operators, brokers, lenders and lending institutions.

\*President, Merchants Association, New York, to the New York Building Congress, upon the announcement of the Congress' new program of a constructive attack on the problems of building for the public welfare.

Those other weaknesses related to land economics, trends of population, analysis of social consequences flowing from an almost total lack of understanding of the larger aspects of the application of the law of supply and demand to real property, are only now beginning to be dimly realized. Any full realization of these aspects will be accomplished only by the slow and painful process of battling against individualism, selfishness and ignorance. The law of co-operation must be substituted for the law of the jungle. Individual opportunity must be co-ordinated with, and made subordinate to, the welfare of the neighborhood and of society as a whole. Capital should not be available for enterprises in real estate improvement which will damage neighborhood in-



vestment or provide housing facilities not needed.

We must forget the lofty towers and turn to rehabilitation; we must turn from the skyscraper, destructive of surrounding values, and look to city planning; we must turn from the marble palaces to reconstructed and modernized housing; we must watch the activities of the Federal Government with respect to housing, mortgage financing, public works, work relief, and social security insurance; these things are of the utmost importance to the building industry. . . .

From every point of view—whether economic, city planning, or actual construction possibilities—rehabilitation and modernization should have first attention. This is proven by the fact that—

- 32 per cent of residential structures in New York are 36 years old or more;
- 24 per cent of the family dwelling units are without central heat;
- 16 per cent without running hot water;
- 15 per cent without tubs or showers;
- 12½ per cent without private indoor toilets.

Similar rehabilitation and modernization is indicated among commercial buildings, and this is proven by the fact that—

- ⅓ of the total loft-building space is in buildings 41 years old or more;
- 30 per cent of the office building space is in buildings 41 years old or more;
- 17 per cent of store-building space is in buildings 41 years old or over.

It frequently has been said that New York is over-built. It is not over-built, but we have too many buildings in the wrong places, and we have filled too many spaces with the wrong kind of buildings. Our building program in New York never has been a program. Buildings have been built from a highly individualistic standpoint, without reference to any reasonable city planning, and without reference to the damage done to surrounding areas. The law protects this kind of development, but that is only because the law lags behind the moral and civic consciousness of the public. It is possible to commit highway robbery on (Continued on page 108)



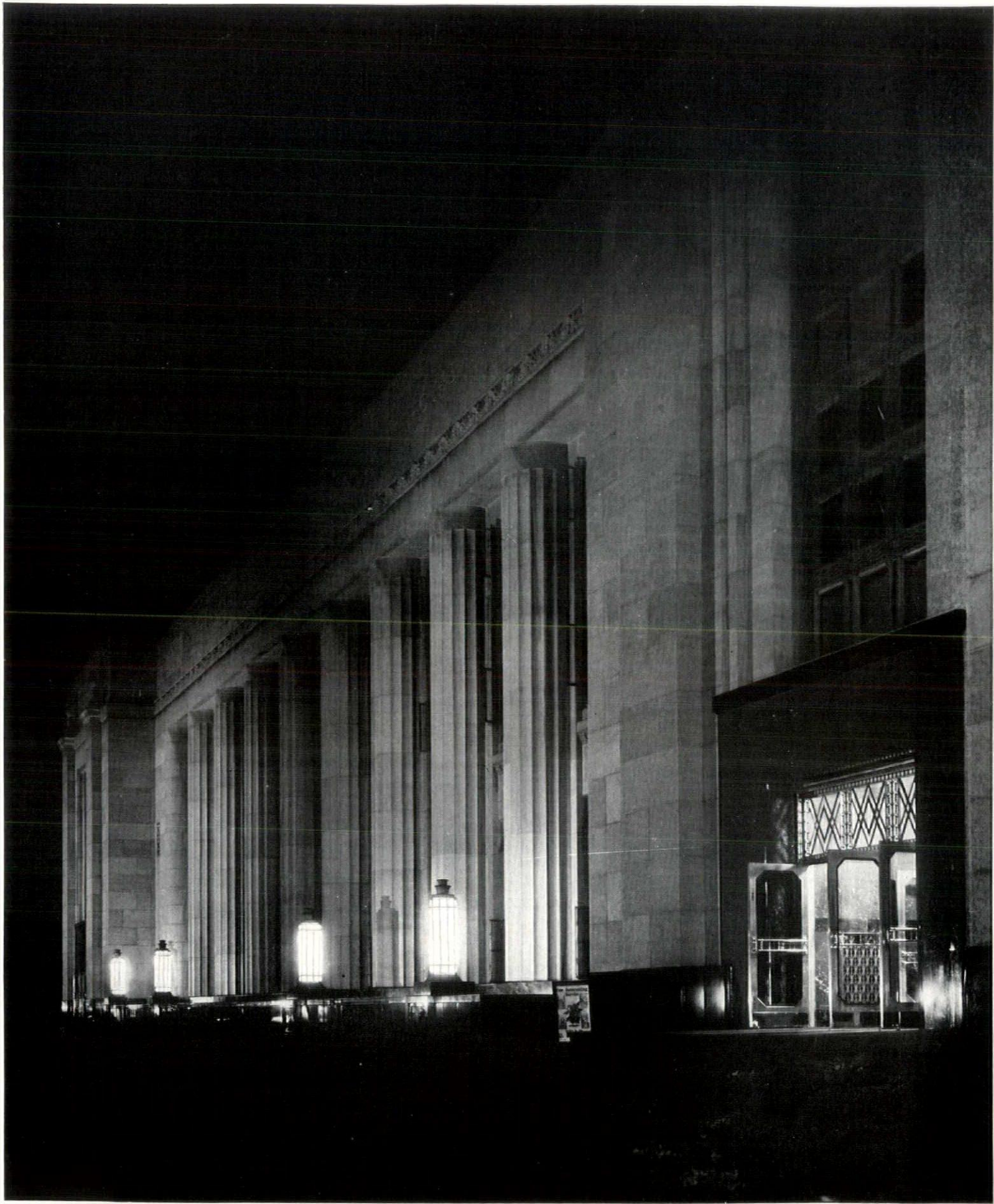



PHOTOS: THOMPSON

U. S. POST OFFICE AND COURT HOUSE, KNOXVILLE, TENN.  
 BAUMANN & BAUMANN, ARCHITECTS

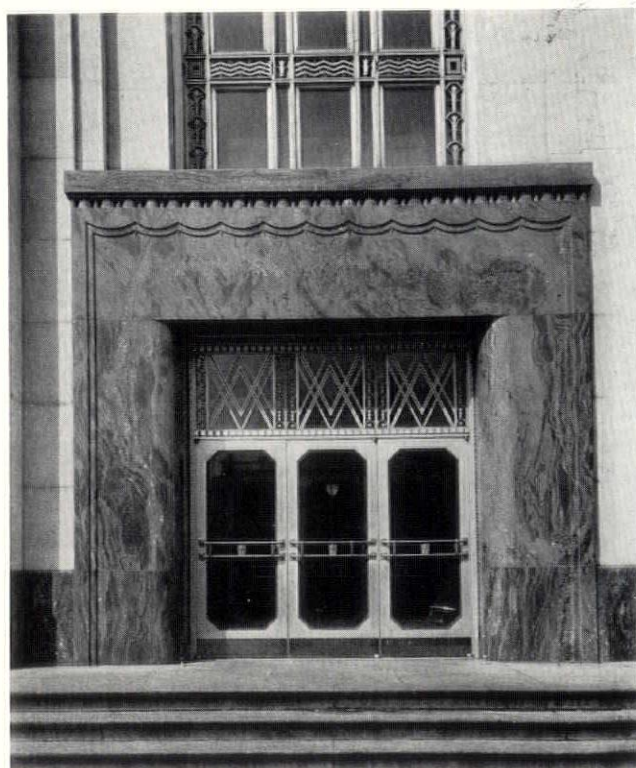

Like most large city Post Offices, this new federal building at Knoxville, provides office space for agents of the federal departments and bureaus, although most of the building is devoted to the Post Office and the United States Court. Located in the heart of the Tennessee marble belt, the exterior is faced with 37,000 cubic feet of Edward and Craig pink marble with a light sand-blasted finish. The base, steps, balustrade and entrance are Rainbow granite. The lighting standards, window casements, grilles and entrance doors are aluminum in a satin and sand-blasted finish



U. S. POST OFFICE AND COURT HOUSE, KNOXVILLE, TENN.

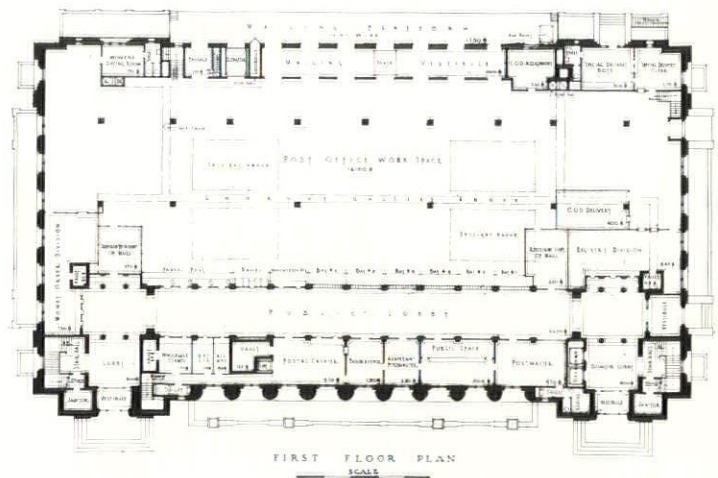
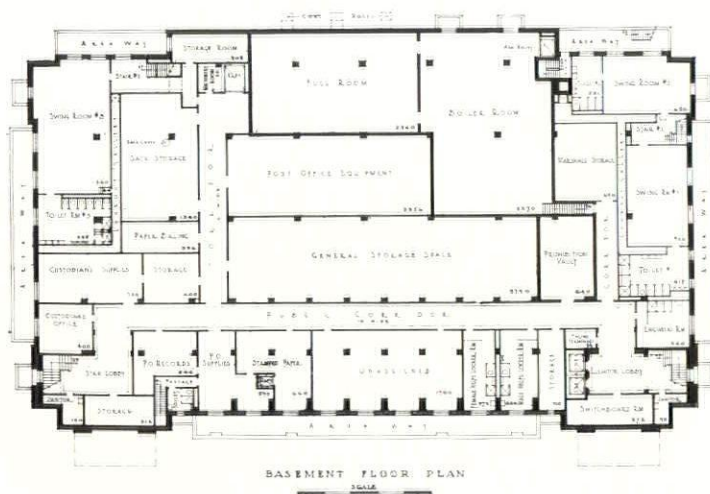



The walls of the court room (opposite page) are maple veneer, stained a Mexican mahogany finish, with Tennessee Fleuri marble for the wall base. The jury box and judge's desk are finished in satinwood and ebony, with panels set in burl maple. The doors, and panels under windows are the same material and stained to match the general tone of the walls. The frieze and ceiling are acoustical plaster. Floor of inlaid cork. . . . At the right is the public lobby. The trim, base, and horizontal bands are Tennessee Fleuri marble, with the fluted pilasters, and frieze in Campania deep rose. The walls are Monteneva marble (Tennessee), and the floors are Hamil pink and Tennessee Fleuri with pattern defined by nickel-silver strips



BAUMANN & BAUMANN, ARCHITECTS

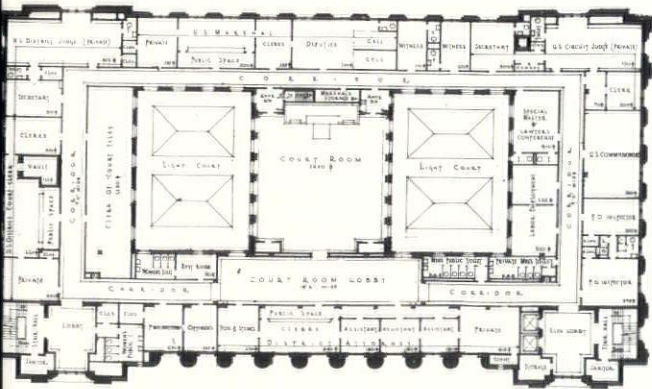

SECOND FLOOR PLAN  
SCALE

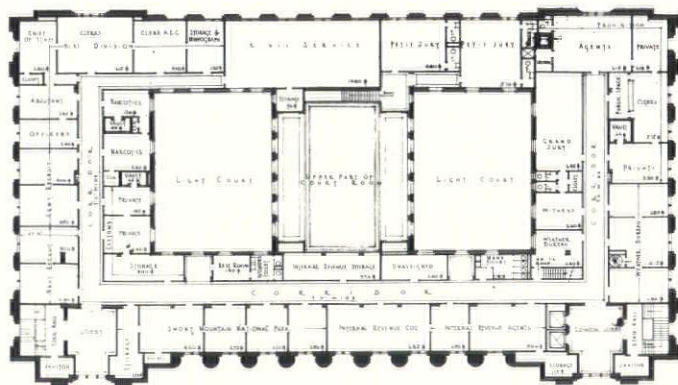

THIRD FLOOR PLAN  
SCALE

# SCULPTURE in the U.S.S.R.

In the Gorki Park of Culture and Rest in Moscow; at right, "The Discus Thrower" in bronze. E. Janson-Manizer, sculptor

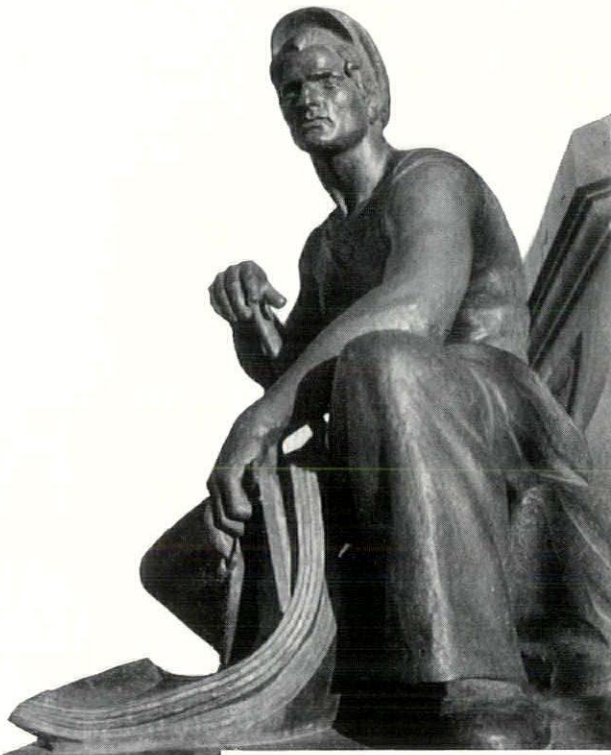

ROVFOFO

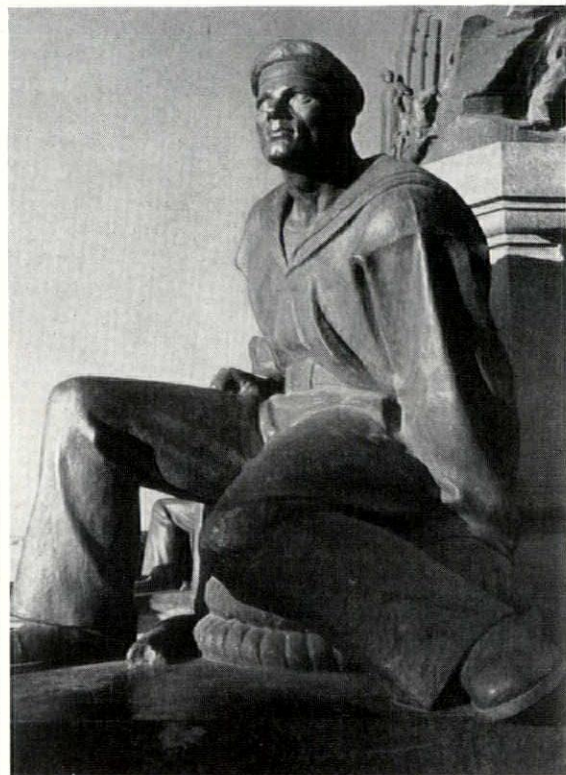

Top, left: Figure of "The Worker"; left and right at bottom are "The Soldier" and "The Seaman," at the base of the Lenin Monument in Sebastopol. V. V. Kozlov, sculptor

# The Legal Side of Architecture

BY CLINTON H. BLAKE  
Blake and Voorhees, Counsellors-at-Law

## Original Architect Cannot Recover for Plans Used for Alterations

WHAT right has an architect to additional compensation based on additions to a building first designed and supervised by him, where another architect designs the additions and makes use in this connection of the original plans and specifications?

This, in substance, was the question recently passed on by the Supreme Court of Nebraska. The architect in the case (*Berlinghof v. Lincoln County*, 257 Northwestern 373) was employed to make plans and specifications for and to supervise the construction of a courthouse. The courthouse was duly built and the architect was paid his agreed commission on its cost. Some time later the County decided to enlarge the courthouse and appointed a new architect to prepare plans for the addition and to supervise the work. Apparently the County gave the new architect a copy of the plans and specifications prepared by the first architect, and the second architect made some use of these in preparing his plans and specifications for the additional work. Plaintiff, the original architect, claimed that he was entitled to a commission for the additional work, in addition to the fee he had already received. The court held:

"Plaintiff is claiming 3½ per cent commission on his estimate of \$125,000, which it would cost to make the changes, alterations and reparations in the building under the new levy for such purposes in August, 1931, and filed his claim before any contract was let for such alterations, reparations, completing or finishing the building (whichever it may be), because he made the original plans and specifications for the building, and that the county permitted the newly-employed architect to use his plans."

### CLIENT'S OWNERSHIP OF PLANS

THESE facts indicate quite clearly that the building was constructed as a complete courthouse on or before December, 1927. There is no allegation that the first contract with McMichael Brothers was left unfinished, or any action taken

by the county board that indicated the contemplation of any changes, alterations or reparations or finishing of the courthouse, until August, 1931, when the new levy was made, which was 10 years after the date of plaintiff's contract. Under these conditions it is apparent that the first contract with McMichael Brothers was complete and at an end, and it follows that plaintiff's contract was fully performed by him and Lincoln County on or before December, 1927. That being established, plaintiff has no further claim on the county; the trial court rightly sustained the demurrer. Plaintiff does not allege that he retained ownership in the plans and specifications, and the county using or permitting C. C. Coursey to use the plans and specifications does not give the right to his commission for their use.

"An architect ordinarily has no right to the ownership of a plan furnished to, accepted by, and paid for by another, and plans forming an essential part of the building contract, unless proved to be the property of the architect, are deemed to be the property of the employer." 5 C. J. 259.

"Further, the county board could not lawfully contract with plaintiff in 1921 to pay him commissions on his plans and specifications at some future and undetermined date, as in this case ten years later. In *Roberts v. Thompson*, 82 Neb. 458, 118 N. W. 106, 107, this court held: 'A county board is not authorized to levy taxes to pay the expenses of subsequent years, nor to contract with reference to levies of subsequent years, nor to create an obligation which would bind the county to levy taxes in the future, unless authorized by a vote of the electors.'

"The appellee asserts that under this statute (Section 26-116, Comp. St. 1929), plaintiff was not entitled in any event to receive commissions on any sum in excess of \$178,690.68, which was the amount raised by the five-mill levy made in 1929, and which five-mill levy was the maximum amount that could be voted to build the courthouse. It will not be necessary to pass on this question in view of our finding that, when the courthouse was completed and occupied and both the contractor and plaintiff paid therefor, it was a completely fulfilled contract and plaintiff had no further rights to commission for his plans."

In so far as the decision is based on the ground that the County Board could not contract in 1921

for the payment of commissions at an indeterminate future date, it is based, of course, on the special Nebraska statute involved. Nevertheless, statutes of this type exist very generally. They are in line with the general tendency strictly to limit the power of any governmental board to bind its successors in office in matters pertaining to public expenditure.

#### ARCHITECT'S SERVICES TERMINATE ON COMPLETION

THE court correctly stated the rule with respect to the ownership of plans. In the absence of a specific agreement to the contrary, the plans belong to the client who pays for them. In the present case, however, even if the usual agreement has been made that the plans should remain the property of the architect, it does not follow that the architect would have been allowed to recover for the new work merely because the County had allowed the second architect to refer to a copy of the original plans and specifications. The important and determining fact was that the work of the first architect had been completed and the additions were a separate job.

Had the original plans or specifications been used in part or in whole as the plans and specifications for the additions, a different situation would have been presented. In that case the contractor, in carrying out the new work, would have been following plans prepared by the original architect. In the present case, the new work was carried out under the new plans and specifications. These were entirely separate from the original plans and specifications. The only use made of the latter apparently was that the new architect had them before him in preparing the plans for the additional work. It undoubtedly was a convenience to him to have the old plans for reference, but had they been inaccessible, he could quite readily have proceeded with the new plans, since the work covered by the original plans had been completed and any measurements and the like which he required could readily be made.

#### ORIGINAL WORK ESTABLISHES NO CLAIMS FOR FUTURE WORK

A DECISION of the court in favor of the plaintiff would have been tantamount to a finding that "once an architect of a building, always the architect thereof." It would have disregarded the well-established rule that, in the absence of a special agreement to the contrary, the services of a professional man may be dispensed with at any time. It would have meant that an owner, wishing to enlarge his building or change it in other respects, would be forced, in order to avoid lawsuits, to employ the original architect, although the new work might have no real relation to the old and might represent an entirely new and separate building operation.

It would be neither good law nor good sense to create a situation of this kind. The architect is entitled to be protected with respect to his own work and to be paid the reasonable value of his own services. He is entitled to be reimbursed for the use of his plans and specifications and the erection of the building which they cover. He can not reasonably seek more than this or ask that he be paid a commission on new work carried out by a different architect because the latter had been shown a copy of the original plans and specifications.

If the parties desire to change the general rule, they can always do so by special agreement. It is legally quite possible to provide, if they wish, that an architect shall act as architect for any alterations or additions in a given job. If such a contract be made and the architect be not employed, he would be entitled to recover as damages the profit which he would have made had he done the work. A contract of this kind, however, would only be called for under exceptional circumstances where, because of special reasons, it is equitable that the usual rule be departed from and the architect be given, in effect, a continuing retainer with respect to a particular building operation.



*—and the*  
GRANDEUR THAT WAS ROME



OTOS ENIT



FLOODLIGHT, THE ARCH OF CONSTANTINE (Above)

THROUGH THE ARCH OF SEPTIMIUS SEVERUS (Right)

TEMPLE OF MATER MATUTA, SANTA MARIA IN COSMEDIN  
BEYOND [PAGE 52], AND RESTORED TEMPLE OF VESTA  
AND HOUSE OF THE VESTAL VIRGINS [PAGE 53]



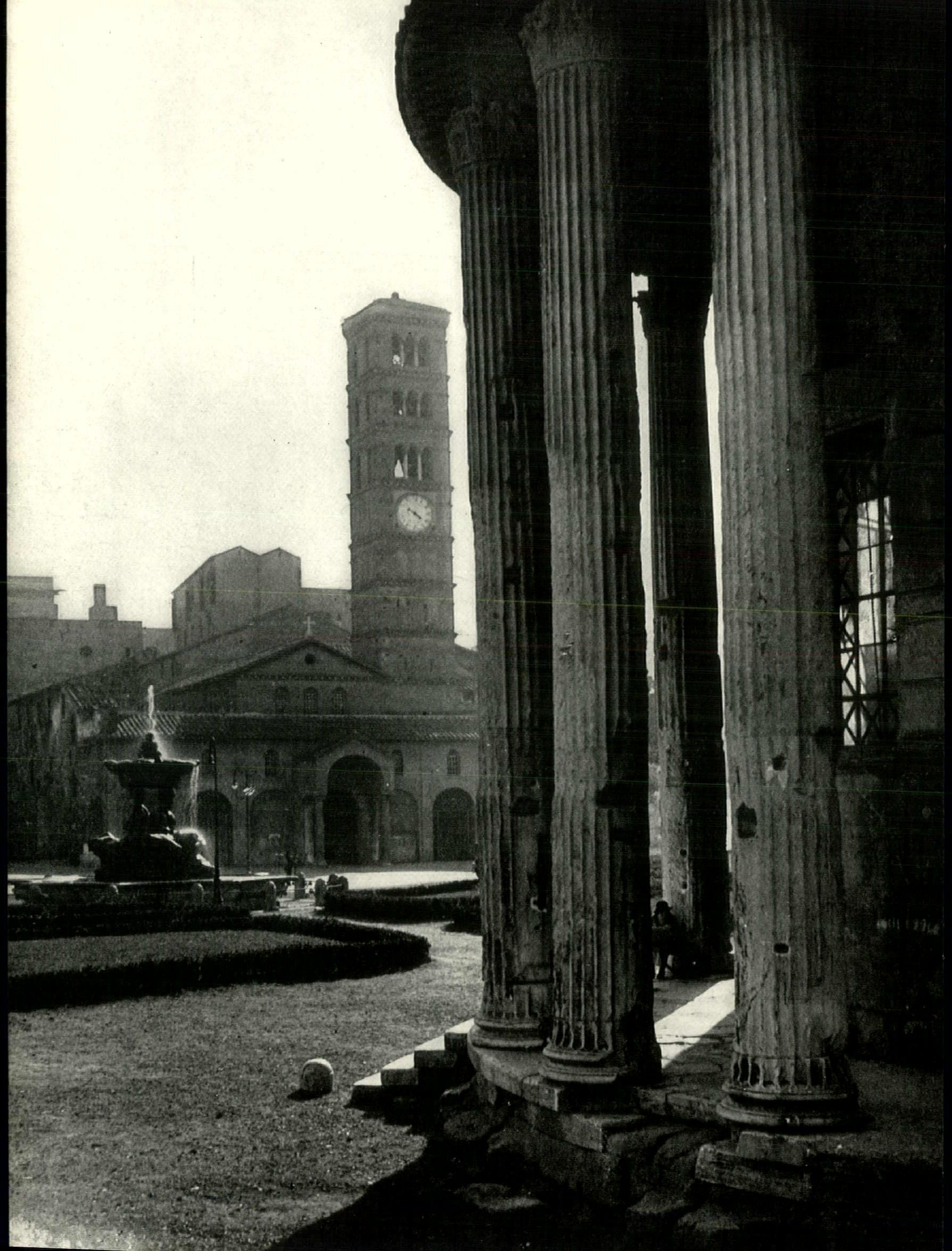







SUNSET LIGHT, ARCH OF CONSTANTINE (ABOVE)

THE COLOSSEUM, THROUGH THE ARCH (RIGHT)





MAJESTIC MASONRY, PALATINE HILL, ROME

# The Boom, The Architect and The Operative-Builder

ALL oracles proclaim an imminent home-building boom. October was the nation's biggest home building month in four years, showing an increase of nearly 110 per cent in residential construction over October, 1934. The home-building curve has definitely started upward, slowly to be sure, but reflecting the increased confidence of the public in recovery. This has resulted from stabilization of the sour mortgage situation, from new safeguards for those who lend on real property, and from the new amortized-mortgage financing plans modeled on the F.H.A.

- The boom will grow. The dwelling deficiency due to the five-year cessation of building activity and depreciations of fire and obsolescence must be made up. Subdivisions which flopped in 1929-30 will be resuscitated and revamped. Thousands of families will buy or build new homes while "values," prices of labor and materials are still low, hoping for ultimate profit on a rising market. They will buy or build in spite of the fact that their equity suffers first when depression deflates values. They will either buy a house ready-made from the developer who has been attracting them with his model homes, or they will build their preconceived "dream homes," with or without benefit of architects.
- The most potent factors in the boom will be the developer or "operative-builder" and the local contractor and realtor, for they have a more direct contact with the buying and building public than the architect. How then, can the architect share more fully in increased home-building activity? How can he be of greater service to the community? How can he assist in raising the standards of site planning, design, construction and equipment?
- Four ways suggest themselves—1. By increasing contacts leading to direct commissions, through publicity, realtors, etc.; 2. By participating as a principal with others in real estate developments; 3. By rendering professional services to the developers; 4. By convincing those who will finance that architectural service is necessary to the protection of their funds.
- The first means increased effort along usual lines; the second, an invasion of the speculative builder's field in direct competition as a proof that architects can produce better values; the third, a co-operation with those who will produce most of the houses to be built—the operative-builder. This third service may vary from acting as consultant in giving constructive criticism of the developer's site plans, house plans and details,—up to providing full professional services, or becoming the developer's employe. The fourth is a matter of educating lenders, and of salesmanship, in order to be retained as architect.
- Should any of these be abhorrent to the profession? Do the ends justify the means? If the ends sought are better land-utilization, more amenities in community site planning, better small house design, higher quality materials, and more honest workmanship, how can they be attained by the architect if he remains aloof? This is not a matter for architectural organizations, but a choice which must be made by the individual architect. Which path leads to the desired ends?

## THE STAGE IS SET

**M**ORE than fifty-eight million lines of advertising based on the "better housing" program of the Federal Housing Administration have been sold by newspapers of the country to space buyers during the past twelve months, as estimated by H. Dorsey Newson, chief of the newspaper section of the FHA. "Eighty-six per cent of the nation's dailies are regularly co-operating in publishing better housing sections. Sixty-three companies specializing in building materials report an aggregate net income of 1,550 per cent in 1935 over 1934." Residential contracts for the month of October jumped to \$55,100,000 in the thirty-seven states east of the Rockies, an increase of 109.5 per cent over October of last year, according to the Federal Home Loan Bank Board. A continued rise in rentals over a nineteen months' period is likewise reported by the board. Federal Housing Engineer, A. C. Shire, estimates that 14,000,000 housing units will be necessary within the next ten years to take care of the demands for new housing. If history repeats itself, it looks as if we are on the brink of a building boom, for certainly the stage is set exactly as it was in the early years after the World War. Architects might take hope in the thought that from little houses, big houses will follow, and then will come the big buildings and big commissions.

## "THINKERS" vs "FEELERS"

**I**N architecture, as in women's clothes, change is inevitable, though fortunately not so sudden. To Sir Giles Gilbert Scott, President of the Royal Institute of British Architects, "the old battle of the styles has existed with us since a live tradition in architecture ceased to exist . . . which may be broadly regarded as a struggle between the 'Thinkers' and the 'Feelers,' and the present controversy of Modernism versus Traditionalism is the same issue under other names. . . ."

"Modernism, by its attempt to approach architecture purely from the functional and materialistic point of view, appeals to the scientific or thinking side of our minds, and by its extremism has made, by contrast, all Traditionalists appear Romantics. Of course, neither school is entirely right nor entirely wrong. The scientific approach to architecture, in so far as it concerns planning, construction and materials, is essential, but this is not enough; man, being what he is, demands something more than scientific satisfaction of his material requirements, nor is the purely artistic approach to architecture enough,

but it is just in deciding where and how this quality that appeals to man's feelings, call it art or what you will, can be brought in that we find ourselves in difficulties. . . ."

"An escape is possible by a certain sacrifice of dogma; for instance, by a more frank recognition of the influence of surroundings upon the choice of materials and the technique of their use. Or could not the advantages of modern developments be combined with materials that, though not modern, have stood the practical test of time far more satisfactorily than some modern materials seem ever likely to do? My plea is for a frank and commonsense acceptance of those features and materials which are practical and beautiful, regardless as to whether they conform with the formula of either the Modern or the Traditional school. . . ."

"Modern developments have undoubtedly brought a breath of fresh air into what had become a stagnant architectural atmosphere, and now that the modern expression has affected most architects, it is to be hoped that it will gradually develop into a tradition enabling all architects to work in the same style." And herein lies the success or failure of modernism of architecture as a business and as an art.

## FOUR MONTHS TO GO!

**T**AKE a good look at these figures and then analyze the possibilities for getting some work started in your office—Apartments, 643,779; Hotels, 29,462; Retail stores, 1,526,119; Wholesale Establishments, 164,170; Manufacturing Establishments, 141,776; Institutions (colleges and schools), 20,267—these are the buildings eligible for modernization under the \$50,000 loan amendment to the National Housing Act. The most important point for you is that this act passes out of existence on April 1, 1936! There is no time to waste in bringing your prospective clients to sign on the dotted line, and developing those potential clients who are still on the fence. What you will do with your opportunities depends largely upon how well you are able to sell your prospects on the idea of the economic necessity of modernization.

## CRAFTSMEN! WHERE ARE THEY?

**A**N old-timer in the building industry writes us —"Steel and cheap labor are not the solution of the housing problem. Prefabricated construction in mass production may be the solution, but not in steel, until steel is cheaper; not in concrete, until concrete is cheaper and more workable; not in

# t o t h e E d i t o r s

plastics, until we know more about their lasting qualities. To save the building industry we need craftsmanship. Unless we consider the intelligence and ability of our future craftsmen, at the first sign of an upturn the monkey-wrench will head us back on the road of speculative nuts and bolts." Private construction companies are already beginning to cry aloud for skilled craftsmen. Where are they? During the past six years we have been unable to develop any new talent. The youngsters who would have followed in their fathers' footsteps have turned to other trades, to C.C.C. or enforced idleness, and hundreds of men active six and eight years ago are now on the retired list. Here is a problem that needs immediate attention from the trade schools, through every branch of the industry, down to the private architect's office.

## DON'T CLOG THE WHEELS

COMMENT by architects from widely segregated sections of the country on the outlook for increased building activity generally, indicates that the cost of construction must be held at its present level; if the headway already gained is to be maintained. A significant fact in this respect is reported by the Dow Building Service report for October, showing that the cost of building in the Metropolitan area of New York—generally where the cost of construction is highest—is less by 14 per cent than in twenty-six other leading cities. With an increasing demand for labor and materials it has always been a difficult matter to prevent a rise in cost. While labor and material manufacturers may deserve increased prices from the low levels which have prevailed for some time, it would seem an unwise move at this time to increase the cost of construction, which would undoubtedly greatly retard the demand for new building.

## SIX MILLION OPEN EARS

SOME sixty thousand schools are now equipped with radio receiving sets, reaching nearly 6,000,000 children, as reported by the Radio Institute of Audible Arts. But you may say, what has this to do with architects and architecture? Young minds are receptive, and young ears are eager to listen—and what is more, these six million youngsters, every one of them, are future prospective or potential clients for the architectural profession. An educational campaign to the youth of the nation via radio might turn the trick in the years to come. Today, we cannot afford to look back—we must look ahead.

## "RE-BUILD AMERICA"

TODAY, America is the greatest potential market on earth for a replacement and modernization movement on a large scale," thinks Clarence Francis, executive vice president of General Foods Corporation. And he backs up his declaration with some startling figures, that should make us all sit up and take notice. "In the United States there are 22,833,000 one-family dwellings. The Real Property Survey of 64 cities last year showed that 2 per cent were unfit for use, 15 per cent needed major structural repairs, 45 per cent needed minor repairs—and these repairs would only make them livable! Only 66 per cent of the city dwellings had hot and cold running water, 8 per cent had no water; 25 per cent had only cold water, 23 per cent had no bathtubs, and 17 per cent had no indoor toilets. In 1932 the number of residence telephones was only 11,089,850. There were in that year approximately 20 million wired homes, 4 million electric refrigerators, 8 million electric washing machines, 9 million electric cleaners and 1 million electric stoves. Think of it!—5,000,000 farmhouses still await electric light and power. In 1933 there was produced only enough paint to supply less than three gallons per one-family residence, inside and out." No wonder we look so bad. Are those critics right who say that America suffers from over-production?

## A CURB TO CONGESTION

WARNING against the creation of new industrial and residential slums with the resumption of building construction in our metropolitan cities, Robert D. Kohn, past-President of the A.I.A., and former director of housing of the PWA, urges drastic changes in zoning laws to curb excessive building heights in the future, and the overcrowding of land, areas, as now permitted. "We must not allow the present opportunity to escape us to put a stop to such further crowding of land as will make the damage irreparable. For instance, the average built-up residential areas of New York now house 189 persons per gross acre. The Lower East Side averages 450 persons per gross acre in its old tenements. Surely not an ideal! Yet one new Lower East Side housing development, financed by the government, has 750 persons per acre. Is there any sense in allowing such congestion?" If the architects of the country wish to become real public servants they can do nothing better than to urge upon the authorities of their city the passage of new zoning ordinances that will prevent such congestion.

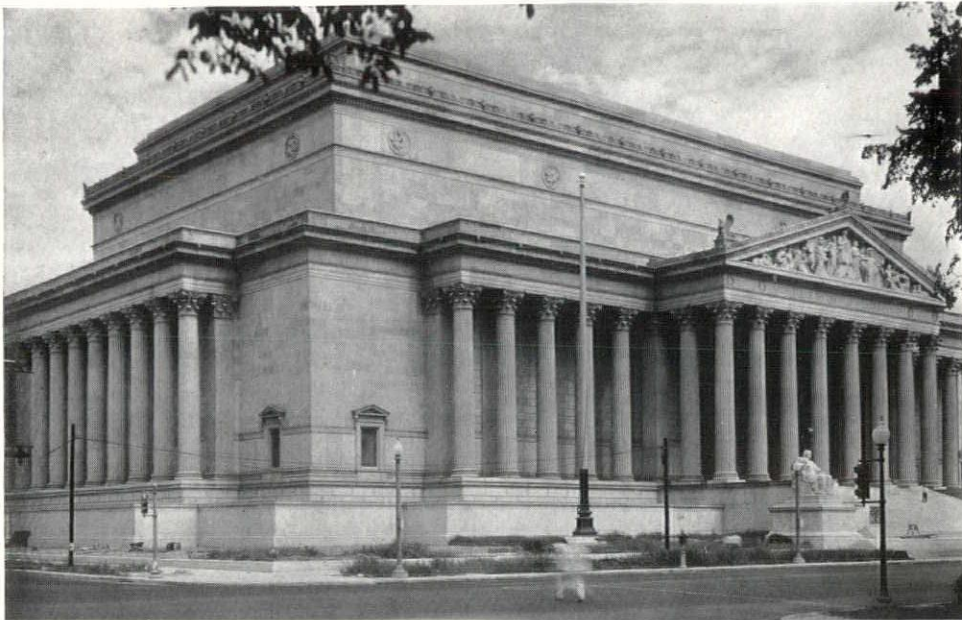

HARRIS & EWING



ACME

Archives Building, Washington, nears completion; Office of John Russell Pope, Architect . . . Top right, demolishing towers of the Trocadero, Paris, to make way for the 1937 exposition . . . At right, the new Rostov-on-Don theater in the U. S. S. R., to seat 2,400; designed by Shchuko and Rilfreich

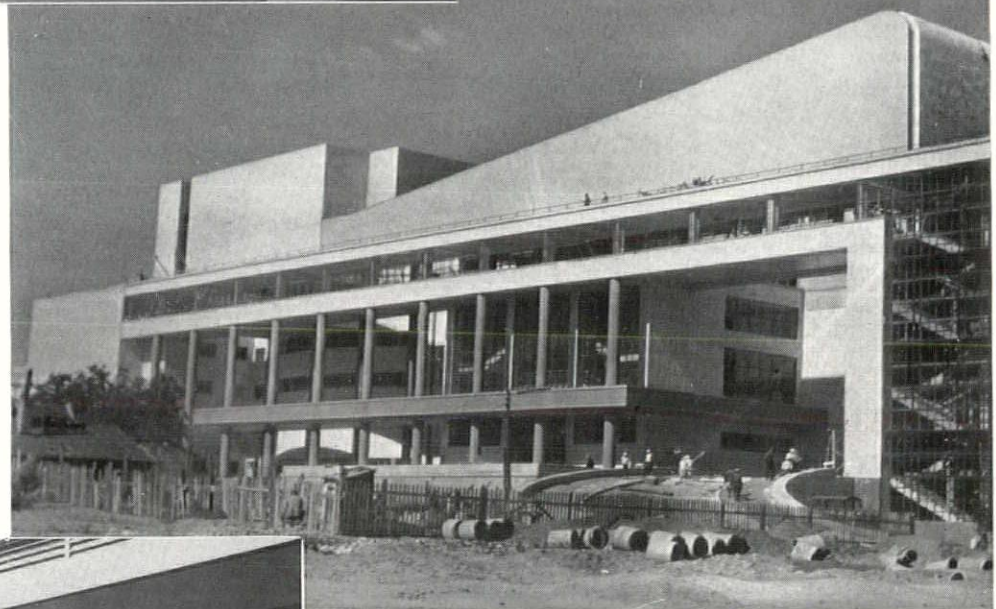

BRYAN-BUCHER



KEYSTONE

Outdoor Kindergarten at Los Angeles, Calif. Richard J. Neutra, Architect

## Trends and

**BUILDING IS ON THE UP AND UP!** . . . The volume of construction undertaken in the thirty-seven States east of the Rocky Mountains reached \$200,863,700 during October, the highest monthly total since Dec. 1933, according to figures by the F. W. Dodge Corp. The figure for September, 1935, was \$167,376,200, and for October, 1934, it was \$135,224,800. The residential total for last month was \$55,100,000, bringing the figure for ten months of this year in this classification to \$394,007,800, against \$214,379,900 for the same period in 1934. The total for all types of construction for ten months this year is \$1,392,561,400.





HARRIS & EWING  
Howard Leland Smith, new chief architect of the FHA . . . At right, 3,300 sets of PWA Housing plans start out with 9,900 sets of "specs," covering 46 projects. Left to right; C. W. Fitch, Assistant Director, Kathleen Brown, Clerk, and A. R. Clas, Director



HARRIS & EWING

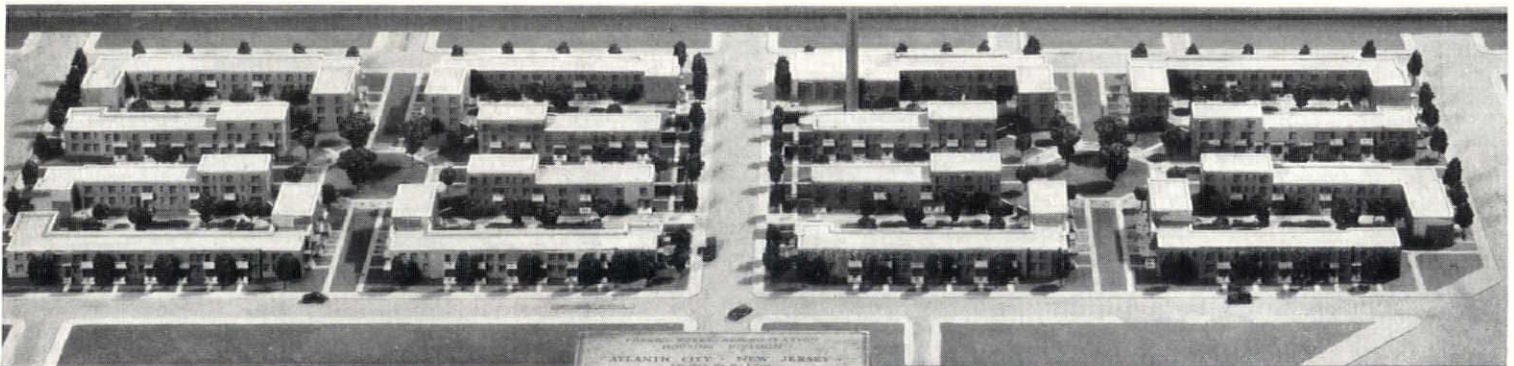

New homes for Atlantic City. Scale model shows how the PWA's \$1,700,000 slum clearance and low-rent housing project will look when completed. The project will provide 337 homes

## Topics of the Times . . . .

**FIVE HUNDRED MILLION FOR MODERNIZED HOMES**  
. . . is the Federal Housing Administration's goal for 1935. The combined total for both modernization loans and mortgages selected for appraisal as of October 16th is \$400,873,742. The breakdown shows individual totals of \$182,255,380 for modernization and repair notes insured; \$197,246,488 for mortgages selected with fees paid for appraisal and \$21,371,874 for low-cost housing mortgages accepted for insurance. 38 per cent of the mortgages accepted for insurance represents new dwelling construction. Federal Housing Administrator, Stewart McDonald, points out that the volume is expected to reach the \$500,000,000 mark before the end of the year.

**"SIMPLER FORMS FOR BUILDING DESIGN . . .** especially in residential design, will be the future trend of architecture," declares Ely Jacques Kahn, New York Architect and Fellow of the A. I. A. "Modernism is not necessarily the goal. The tendency is towards clean forms in which the merits of materials will be enhanced by honest presentation. There will be more construction in glass." This may be true with the announcement of the Owens-Illinois Glass Company of the development of an improved glass block which has stood up under pressures of 72,500 pounds to a single block and is said to reduce heat flow, deaden sound, transmit and diffuse light, deflect sun glare and resist fire. Pre-cast concrete and other old and new materials will be developed in 1936.

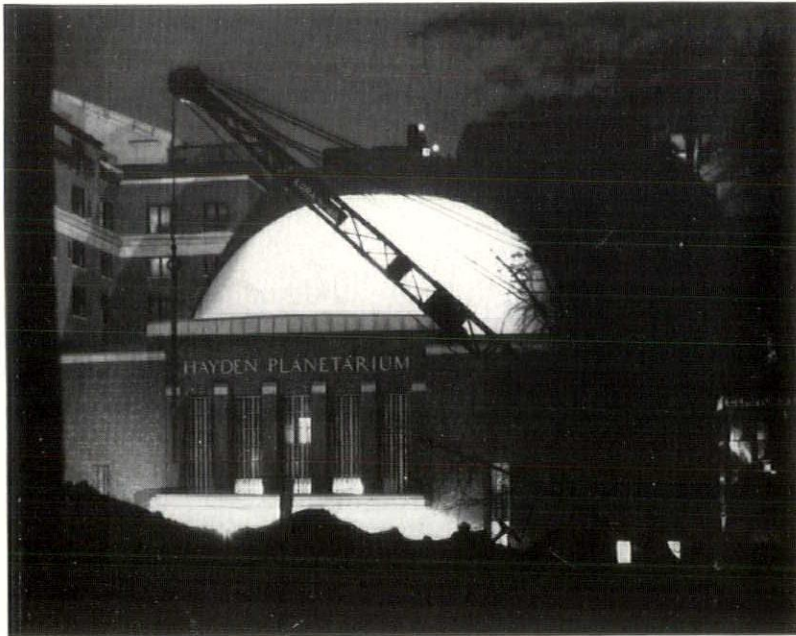

CHAS. PHELPS CUSHING

- A signal system which is described as the "electric weather man" has been installed in the windowless office building of the Hershey Chocolate Corporation at Hershey, Pennsylvania, which indicates the weather conditions outside. A small brass panel near the electric clock in each office has three colored glass bull's eyes with a miniature electric light behind each; the colors are red, white and green so that seven different combinations have been adopted to keep the occupants posted on weather conditions. White will indicate clear weather; white and green, cloudy; red, rain; red and green, sleet; green, snow; red, white and green, clear with temperature above 90 degrees.

- The Federal Housing Administration has outlined the policy it will follow in regard to the eligibility of equipment and machinery obtained under the Modernization Credit Plan in a booklet recently released. There is a complete list given of equipment that has been ruled eligible for loans up to \$50,000 for apartment houses, multiple family houses, hotels, office—business or other commercial structures—hospitals, colleges, orphanages, schools and industrial plants. It also gives the policy, in detail, regarding loans up to \$2,000 on other types of property. Copies are available at FHA headquarters, Washington, or at State and District insuring offices.

- The Miller dual-bond bill, which passed the last session of Congress, compelling contractors to post two bonds, requires that all contracts for the construction, alteration and repair of any public building or public work of the United States shall be accompanied by a performance bond protecting the United States, and by an additional bond for the protection of persons supplying materials and labor for such work.

*(Continued on page 95)*

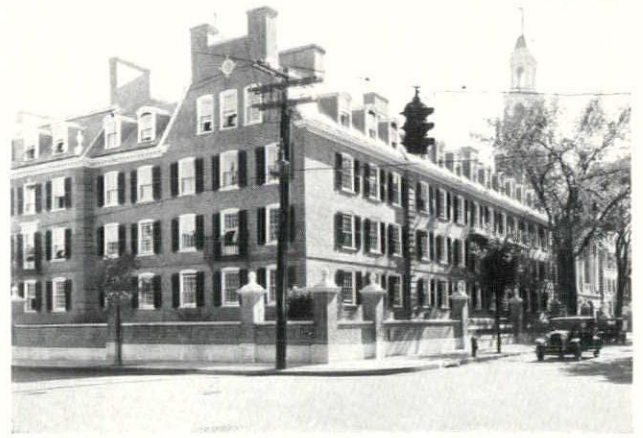

WIDE WORLD

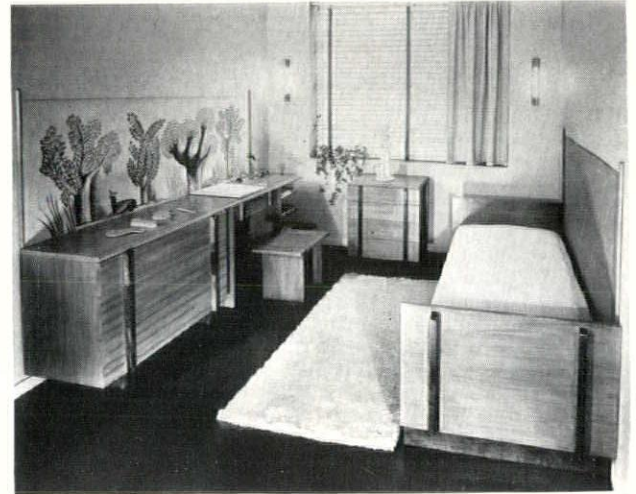

WYATT DAVIS

The New Hayden Planetarium, New York, is shown at top left, as it neared completion. The building was opened to the public late in October. Trowbridge & Livingston, Architects. Top right, Timothy Dwight College, the new undergraduate unit just completed at Yale University. James Gamble Rogers, Architect . . . Modernistic information booth in the Socony-Vacuum Exhibit in Rockefeller Center, New York, Henry Dreyfuss, Designer, is seen in the center . . . Bottom right, modern nursery room, designed by Ilonka Karasz, for Saks Fifth Avenue Store, New York. All furniture designed at small scale



B. ALTMAN

Curtains of white Cellophane and lemon cotton thread in horizontal stripes in penthouse living room. The sofa is upholstered in a novelty basket weave cotton, from France, in gray, brown and lemon. The lounge chair is covered with lemon terry cloth

## TEXTILES . . .

# TEXTILES . . .

## PART II—FABRICS

AMERICAN ARCHITECT "MATERIALS IN DESIGN" SERIES NO. 6  
PART I, DEALING WITH CARPETS, APPEARED IN SEPTEMBER

BY CARL T. SIGMAN AND WILLIAM J. WARD, JR.

**M**ODERN textiles can properly be called one of the newest and most adaptable of architectural tools. More and more the field of architectural practice embraces the design of interiors and includes the selection of every item of furniture and decoration. Thus to architects a knowledge of textiles becomes increasingly essential. A complete study of the subject obviously is not possible within limits of an article. But the following paragraphs outline the characteristics of "architectural fabrics," those textiles that are variously adapted to interior design and with which the architect will be most concerned:

Thousands of fabrics are today available to the designer. Thousands of variations exist in pattern, texture and color. But fundamentally all textiles can be placed in one of three weave classifications. First, *plain weave*, in which the warp and weft threads are approximately equal in spacing and thickness, one woven alternately over and under the other. Second, *twill weave*, in which two or more warp threads are passed over and under one or more weft threads in regular succession. Third, *satin weave*, in which the bulk of either warp or weft shows predominately on the face of the fabric. In a true satin the warp shows, in sateen the weft. The surface thread on the face of the fabric in either satin or sateen is always the finer one. In fine cloth threads are woven so closely that the fabric has the appearance of having all the threads on the surface. These fine parallel threads are softer to the touch than plain or twill weaves. They reflect rather than diffuse light thus giving satin or sateen its characteristic sheen. It must be understood that technically the terms *plain*, *twill*, or *satin* refer to weaves and not to materials, although twill and satin are commonly and commercially referred to as materials.

From these three fundamental weaves are developed a multitude of variations as to pattern, texture, color and material. Fabric materials are largely limited to eight fibers, although combinations of two

or more of them and variations in the textures of the materials themselves can produce nearly an infinite combination of finished fabrics. The fibers are:

1. Rayon—a synthetic fiber from cellulose
2. Cotton—fiber around the cotton seed
3. Linen—fiber of the flax plant
4. Mohair—fleece of the angora goat
5. Silk—cocoon of the silk worm
6. Wool—fleece of the sheep
7. Jute—fiber of an Indian plant
8. Ramie—Indian plant fiber

Of all these silk is the longest natural fiber, ranging from 400 to 1300 yards in length. It is also one of the strongest and most elastic.

It can be readily appreciated that within the limits of these three weaves and the eight basic weaving materials nearly a limitless number of fabrics can be developed. Obviously, not all of them are adapted to use in architectural interiors. And the following paragraphs will, therefore, be concerned only with those which the architect might naturally consider in the development of an interior design:

### UNFIGURED FABRICS

**N**EVER before in the history of weaving has there existed such a great number and variety of beautiful unfigured fabrics. They have been created through the use of the three fundamental weaves combined with variations in construction, yarns and coloring.

For example, one of the constructional variations is produced by weaving rough weft threads with smooth and regular warp threads or vice versa. Produced thereby is a wide range of unevenly surfaced fabrics such as shikii and cloister cloth. Again, by passing groups of weft threads over and under groups of warp threads, another group of loose textured fabrics—the basket weaves—can be obtained.

Reps and cords, an important drapery and upholstery group, have been developed by weaving

heavy warp threads with fine weft threads or the reverse. Still another group owes its distinctiveness to various methods of finishing. Moiré, for example, is made commercially by a process that passes the cloth, dampened and folded or rolled, between hot rollers. Changeable silks and taffetas owe their shifting colors to a use of a warp of one color or shade and a weft of a different color or shade.

One of the earliest methods of introducing color was to lay in the warp in stripes of contrasting tones. This effect, known as Imberline, is achieved in all sorts of widths and colors and constitutes the nearest approach to design in plain fabrics.

There are two other effects known as strié and jaspé. Modern strié effects are produced by using warp threads contrasting in tone. Each individual thread, however, is uniform in color from one end to the other. They appear in the fabric as parallel streaks varying in width. Jaspé, on the other hand, obtains its mottled, marble-like effect from a warp in which the individual threads are not uniformly colored and appear in broken lines. Both give us plain fabrics that belie their names in a complex play of color.

### DAMASK

TODAY when a plain, twill or satin weave incorporates figured designs, the lines of which run in a different direction from those of the background, the fabric is called damask. This is ordinarily woven in one color, and the ground is either a satin with figures of contrasting weave, or else the figure is satin with a ground of contrasting weave. Although most damasks are woven in monotone, many contain a contrasting color for the figure. Modern damask is fabricated not only in silk, but in cotton, woolen, linen, mohair artificial silks and various combinations of these.

Although damasks woven for draperies are usually reversible they need not be, although any that are not reveal the pattern clearly on the back.

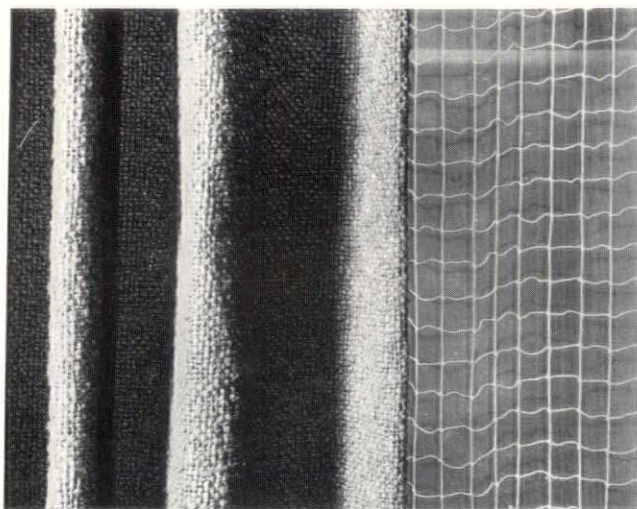

PHOTO: F. S. LINCOLN

A study in contrasts; monks-cloth and fish-net used as modern curtains in a furniture show room. Frederick Kiesler, Architect

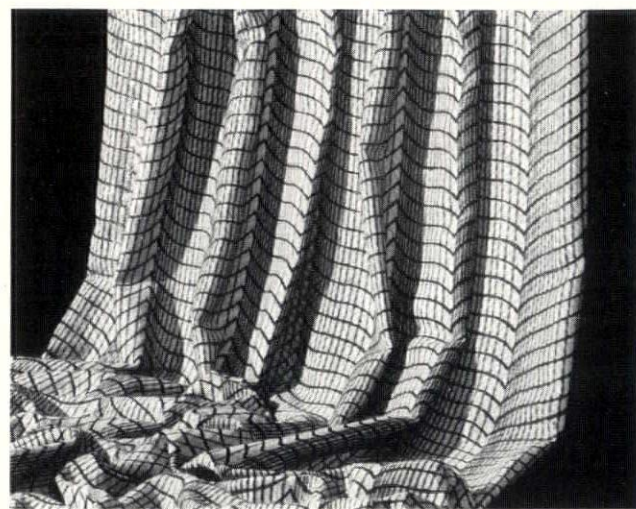
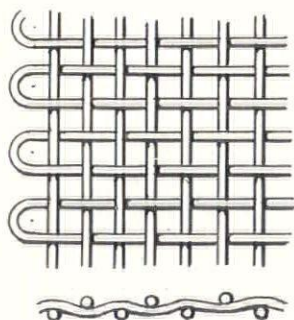
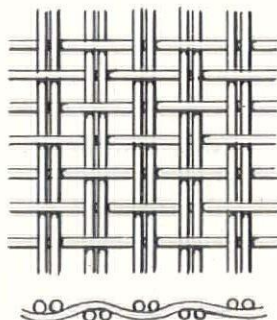

PHOTO: FRANK RANDT

Goodall printed mohair, designed by Ely Jacques Kahn, Architect, for exhibit in the Metropolitan Museum of Art, New York



PLAIN



TWILL

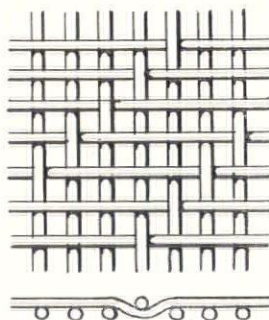

SATIN

### BASIC WEAVES FOR TEXTILES

The terms Plain, Twill and Satin refer technically to weaves and not to materials, although Twill and Satin are often referred to as materials. From these three fundamental weaves are developed a multitude of variations as to pattern, texture, color and material



W. & J. SLOANE

The draperies are rose and beige mercerized cotton stripe; valance, rose damask with painted rings of wood, in the library, above. The love seat is glazed chintz, the rug is of hooked wool



B. ALTMAN & CO.

The draperies in the dining corner, above, are printed rayon satin in gray, jade and bright blue. The seat and side chairs are upholstered in monks-cloth of oatmeal color

For hotel rooms, draperies with an interwoven lining as opposed to lined curtains are suggested. Although the original material cost would be greater, the purchase cost and maintenance would be less.

Originally both warp and weft of damask were of silk, but today cotton is frequently woven with silk, giving a softer sheen. Damasks of a high sheen are often woven of silk, artificial silk and mohair. Wool damasks have a soft rich depth particularly desirable for certain interiors. Linen damasks are usually woven for table cloths and napkins.

Damasks today are made on a Jacquard loom similar to those used for Wilton and Brussels carpets.

### BROCADELLES

**B**ROCADELLES are simply a variation of the damask weave, made on the Jacquard loom. Coarse weft threads beneath the surface throw the satin figures into bold relief against a twill ground. The resulting raised effect, almost sculptured in quality, is perhaps closer to velvet than to either damask or brocade.

Because the weave is adapted to bold effects and the designs tend to be large and striking, brocattelle is a material worth considering for high-ceilinged banks, hotel dining rooms, etc.

### BROCADES

**B**ROCADES while usually grouped with damasks and brocatelles, under the heading of ornamented silk, are distinctly different from either. In contrast to the simpler tones of damask, brocades are made in an infinite variety of colors. They resemble hand embroidery standing out against a rich ground of any one of the fundamental weaves—plain, twill or satin.

Brocades can be made of any material, but were developed first in silk. Often the embroidery effects are produced by threads of gold or silver, although the metals will eventually tarnish. A rare type has both background and embroidery in metal. Unlike damasks, brocades are not reversible.

### VELVETS, VELOURS, PLUSH

**V**ELVET, more than any other fabric, denotes richness in the popular mind. In addition to silk, velvets are made of linen, cotton, wool and mohair. One of the oldest in existence is a Coptic velvet of linen with a wool and linen pile.

Velour is simply the French word for velvet and theoretically there is no difference. However, velour has come to mean a velvet in which rows of pile



PHOTO: MATTIE EDWARDS HEWITT

Terra cotta Cellophane has been effectively used for the draperies in this living room, decorated in the modern manner. The furniture is upholstered in a dead white rough-textured fabric of cotton and silk. The floor covering is black chenille carpet. Jane Smith, Inc., Decorators



L. C. CHASE & CO., INC.

Hand-printed mohair in a simple, but colorful, floral pattern. Many color combinations can be secured

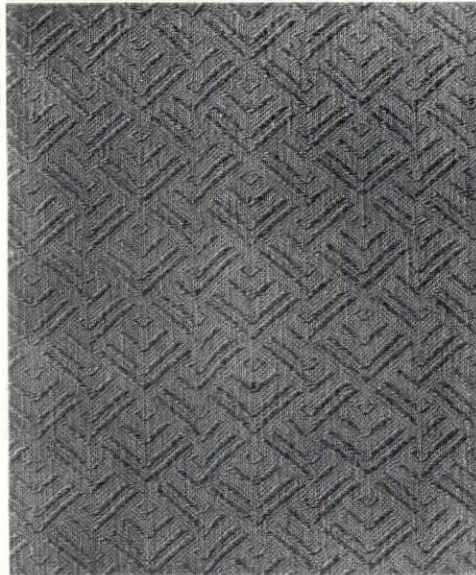

A mohair with Chinese Chippendale influence in its woven pattern; bright Mandarin colors, interesting texture



Printed mohair, conventionalized fern pattern, which may be had in a variety of colors to suit a color scheme

## DEFINITIONS OF FABRIC TERMS

**ARMURE** . . . Ribbed silk or cotton fabric usually with a small design formed by the warp floating on the surface.

**ARTIFICIAL SILK** . . . Highly lustrous vegetable fiber produced from the cellulose of plants. Materials of this fiber are now called glos or rayon.

**BATIK** . . . Figured fabric produced with a wax resist and successive dyeings or paintings after an ancient Javanese process.

**BLOCK PRINTS** . . . Fabrics patterned by the application of engraved wooden blocks applied in the same manner as a rubber stamp.

**BROCADE** . . . Figured silk fabric usually of many bright colors and raised designs made on the loom by floating wefts on satin or grosgrain grounds.

**BROCATELLE** . . . Heavy fabric, similar to a damask, having a linen filling which gives it an embossed effect.

**BROCHE** . . . French term for brocade, also for the bobbin used to carry the colored filling across the width of the design on a hand loom.

**CALENDERING** . . . A process of rolling fabrics between cylinders, usually heated, to produce a smooth glossy surface.

**CHINTZ** . . . Closely woven cotton fabric, printed in soft color and fine designs.

**CLOISTER CLOTH** . . . Cloth of a rough appearance made of coarse cotton yarns.

**CRETONNE** . . . Cotton fabric of heavier texture and bolder design than chintz. If linen, it is called printed linen.

**DAMASK** . . . Reversible fabric usually in one or two colors woven with the lines of the figures running in the opposite direction to those of the ground.

**EMBOSSSED** . . . Effect obtained by treating fabrics between engraved rollers so the design appears in high relief on the surface.

**FAILLE** . . . Heavy corded silk of the rep variety with wider and more pronounced cross-ribs than grosgrain.

**FILLING** . . . See **WEFT**.

**FRIEZE OR FRISE** . . . Velvet of linen, wool or other yarns, which shows the looped or uncut pile. Also called Bouclé.

**GLAZED CHINTZ** . . . Chintz with a surface treatment of sizing and calendering to obtain a glossy finish and stiff texture.

**GROSGRAIN** . . . Ribbed or rep silk woven with heavy weft threads covered with fine warps. A heavy ribbed taffeta.

**GROS POINT** . . . Heavy embroidery stitch done on canvas with two or more foundation threads giving the effect of tapestry.

**IMBERLINE** . . . Striped effect produced in a fabric by laying the warp in colors.

**JASPE** . . . Irregular striping of the same color. It is produced by dyeing yarn twice. First the entire skein is dipped in a light dye then portions of it in a darker shade. From the French word meaning marbled.

**MERCERIZED** . . . Treatment of caustic soda and tension which gives cotton yarn the smooth lustrous surface of silk.

**MOHAIR** . . . Wool-like fiber derived from the fleece of the Angora goat and used for many upholstery and drapery fabrics.

**MOIRÉ** . . . Silk fabric which has acquired a watered appearance by passing dampened between cylinders which flatten the surface in irregular wavy lines.

**NINON** . . . A sheer weave of Celanese.

**ORGANZINE** . . . Best quality of silk yarn. It is twisted or "thrown" from many strands of raw silk and used particularly for the warp in taffeta and other silk fabrics.

**PANNE** . . . Pile fabric which has been flattened by pressure so that the pile lies close to the back giving a shiny appearance.

**PETIT POINT** . . . An embroidery stitch on canvas with one foundation thread in contrast to the two or more threads of gros point.

**PLAIN WEAVE** . . . The completed alternation of warp and weft at right angles.

**PLUSH** . . . Cut-pile fabric of silk, mohair, cotton, linen or wool, with a deeper pile than velvet.

**POPLIN** . . . Finely woven fabric of silk or high lustre cotton yarns with light cross-ribs and very fine warp.

**RAMIE** . . . Fiber shredded from the stalk of a plant grown in India. Its characteristics are similar to those of linen and it is used for the same purposes.

**REP** . . . Ribbed fabric made of silk, mercerized cotton or wool having fine warp threads covering the entire surface.

**SATIN** . . . A weave in which the bulk of either warp or weft shows predominantly on the face of the fabric.

**SHIKII** . . . Rep with a slub yarn filling (a yarn with evenly recurring thick and thin portions).

**SHOT** . . . The number of weft threads considered in reference to the tufts or loops of surface yarn. 2-shot means that there is one weft thread between each row of pile tufts. 3-shot means three weft threads to each row of tufts, one on the back and one on each side. 3-shot, requiring more material and more loom motion, adds to cost, but increases durability.

**STRIE** . . . Striated effects or streaks of different widths produced by the use of warp threads which vary in tone.

**TAFFETA** . . . A plain, closely woven, smooth silk fabric with warp and weft of the same or nearly the same count.

**VELOURS** . . . Cut pile fabric of more open weave than velvet, with the rows of pile showing distinctly against the ground.

**VELVET** . . . Pile fabric forming its soft compact surface by a second warp woven into the loops and then cut out or left as woven.

**WARP** . . . Threads which run the length of the cloth and are first set up in the loom.

**WARP PRINT** . . . A fabric with the design printed only on the warp and then woven.

**WEFT** . . . Threads which run from one selvage of the cloth to the other. Also wool or filling.

show distinctly against the ground in contrast to the compact pile surface of ordinary velvet. Plush is simply a deep pile velvet.

All three types may be plain or figured. Sometimes the pile has two depths showing the design in relief above the group known as *Deux Hauteurs*. Cisélé is a velvet with figures chiseled out in fine lines on a plain velvet background. Another type, known as *Velours de Genes*, is characterized by velvet figures on a satin background.

Usually velvets are woven like Axminster carpets—that is, the pile is woven over wires on the ends of which are blades which, when withdrawn, cut the pile. When the pile remains uncut the same weaving process produces fabrics known as uncut velvets, frieze or bouclé. Frieze is generally woven of linen, wool or mohair rather than silk, and is a very durable upholstery material, particularly when mohair is used. Plain velvets are woven face to face and then cut apart, forming two pieces of fabric.



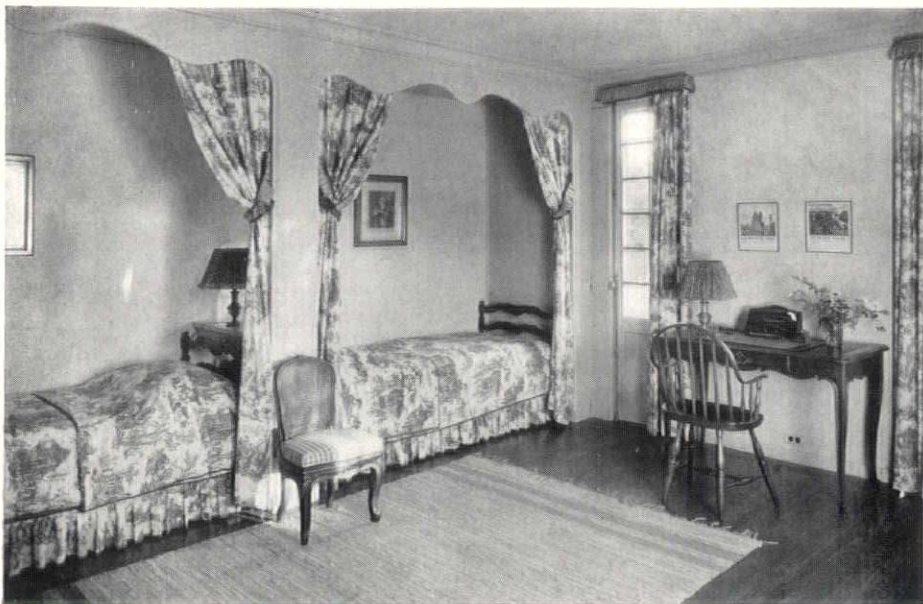

PHOTO: MATTIE EDWARDS HEWITT

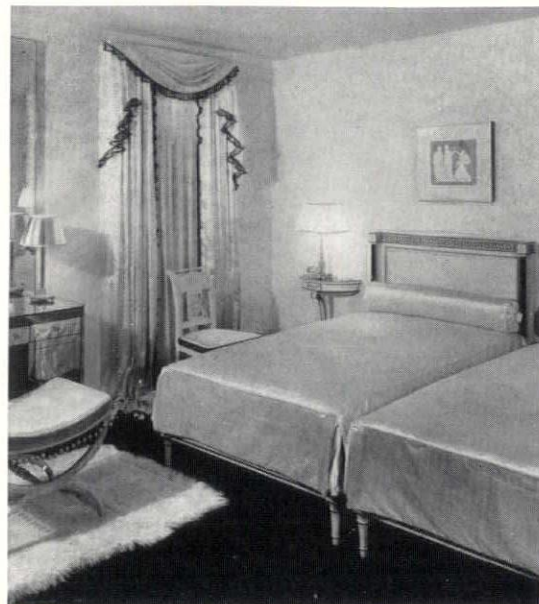

PHOTO: ROBERT E. COATES

Toile de Jouy chintz has been used for the curtains, hangings and bed covers, in the guest room at the left. Nancy McClelland, Decorator. . . . At right, the bedspreads are of white flat pile velvet. White duPont rayon satin was used for the upholstery, combined with red moiré rayon on the straight chair. Draperies are of the same fabric, with which are used glass curtains of white rayon voile. Decorated by The Hampton Shops. Fabrics by Whitcombe McGeachin

Velvets, velours, plushes and friezes are all drapery and upholstery materials, friezes being used almost exclusively for that purpose. Being subject to pile crush, silk velvet is usually more satisfactory for draperies than for upholstering although this is not true of mohair velvet

## CHINTZ AND CRETONNE

CHINTZ was originally an Indian importation. In fact its name is derived from "chint," the Hindoo word for printed cloth. In later years it has come to mean a lighter fabric with small English patterns, while cretonne—named for Creton, a French village widely known for its prints—now signifies a somewhat heavier fabric with bolder design. Today both chintz and cretonne are made mechanically.

Patterns are either hand-blocked or machine-printed. Hand-blocked prints have a softer, less mechanical appearance than the printed chintzes and are usually the more expensive. When seen together the two are easily distinguishable.

When a vitreous brilliance is desired for a flat surface, chintz may be lacquered thus producing a hard texture and pronounced high lights. A second process of rolling the fabric repeatedly between steam filled cylinders produces the flat, burnished aspect of Indian calendered chintz. A third method involving the addition of a starch solution gives the stiff body as well as the gloss to glazed chintz. In order to produce a surface impervious to dust, another kind of finishing has been recently perfected—a semi-glaze which retains the softness of an unglazed fabric.

Chintz and cretonne are both ideal as drapery and upholstery materials. They are useful also as slip

cover materials where cheerful effects are desired and more durable materials are not required. Glazed chintz can be mounted on walls in place of paper and is adaptable to a wide variety of uses particularly above a wainscoting, creating interesting effects.

## TAPESTRY

CONTEMPORARY tapestries are influenced by three historic schools of weaving. At Arras the first Gothic tapestries were woven. With the passing of the Gothic age, Brussels became the second great tapestry center. Here were made the finest tapestries of the Renaissance. Paris in turn rose to fame as her celebrated Gobelin works developed, holding its prestige to this day.

Occasionally tapestry proves ideally adapted to upholstery for the design can be proportioned perfectly to any size or shape. The fabric withstands very hard wear and with skill can be restored to its original beauty after years of service. The user's choice of tapestries depends upon the size, age, beauty and cost.

Many fine tapestry fabrics are still woven by hand, but commercial tapestries are produced on the Jacquard loom.

## MOHAIR

MOHAIR is made from the fleece of the Angora goat. Once the exclusive and officially guarded possession of Turkey, Angora goats were introduced to America in 1849. Today there are more than 5,000,000 Angoras roving the western plains and this country has become the largest producer of mohair in the world.



W. & J. SLOANE



PHOTO: F. S. LINCOLN

LORD & TAYLOR PHOTO: RICHARD AVERILL SMITH

Glass curtains of Cellophane and ratiné are used in the room at top left. . . . In the living room, top right, the draperies are chintz; glass curtains, white Celanese. The love seat is upholstered in cinnamon corded wool rep, and the chair in white, green and beige chevron damask. . . . At far left, the draperies are satin, the floor covering is Chambray carpet in two-tone champagne color. . . . At the left, the curtains are cerulean blue sheer chiffon velvet, with tassels in silver bullion. The sash curtains are silver net, and the draw curtains silk, in shaded blue and coral. Miss Gheen, Inc., Decorator

Under a microscope, the fabric appears as a hair without the bristles of wool, but similar in many other respects. It is fine and lustrous and particularly capable of shedding dirt, which for draperies and upholstery in public buildings is a highly important factor.

Mohair today is woven into an astonishing variety of smart textures and weaves ranging from a soft, sheer glass curtain material to a heavy plush. The smoothness of the angora fleece gives to mohair a brilliant and lustrous sheen when dyed. It will not fade readily and absorbs color evenly. It is, therefore, suitable for slip covers, glass curtains and draperies. More resilient than wool, mohair does not crush and is, therefore, a proper material for slip covers and upholsteries. Mohair velvets and plushes are more than twice as strong as similar woolen fabrics and the fact that it is extensively used in railway cars,

buses and private automobiles is an indication of remarkable durability. Considering that re-upholstering costs are usually greater than fabric costs, the increased original outlay is really an economy.

Besides velvets and plushes, beautiful friezes, reps, hand-blocked and printed fabrics are available for theater seats, hotel lobbies, offices, etc.

Chemists have perfected a solution which makes mohair mothproof when it is dyed. The treatment is generally in use and some manufacturers will replace any mohair that has been moth-eaten at any time while in use.

## RAYON

IN 1878, Count Hilaire de Chardonnet, from his study of the silk worm, conceived the idea of synthetically "digesting" the cellulose content of mulberry leaves to produce silk filaments. That in

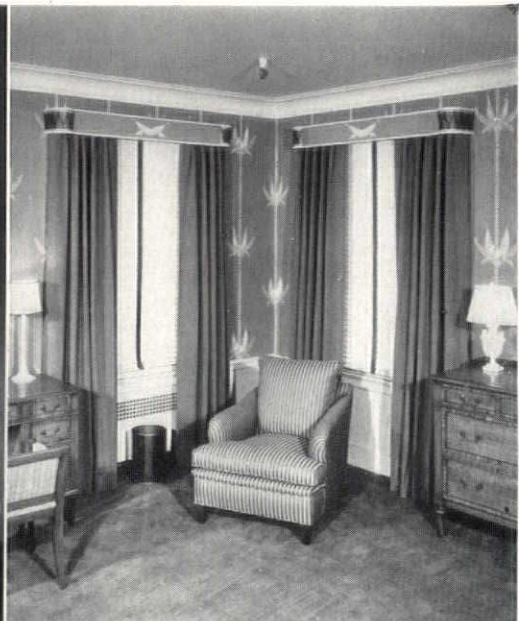
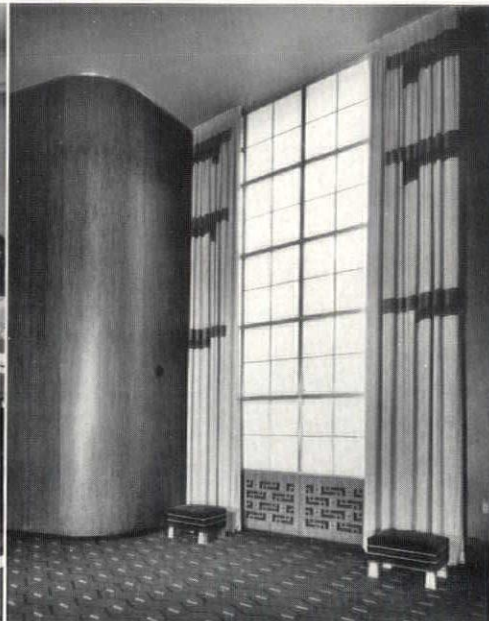

ORINOKA MILLS, INC.

PHOTO: F. S. LINCOLN

VARIETY IN DRAPERY FABRICS AND MATERIALS FOR CURTAINING

Gray quilted matelassé lined with fuchsia silk satin was used for draperies in the room at top left, with white woven glass curtains. . . . The draperies in the center picture (Rockefeller Center Music Hall) are silk in champagne color; the horizontal bands are suede in blue and red. Eugene Schoen & Sons, Decorators. . . . At top right, wine pebbly silk rep curtains; easy chair, upholstered in blue and tan damask. . . . Below, the over draperies are of Celanese in lake blue, with white Celanese for the curtains. Diane Tate and Marion Hall, Inc., Decorators

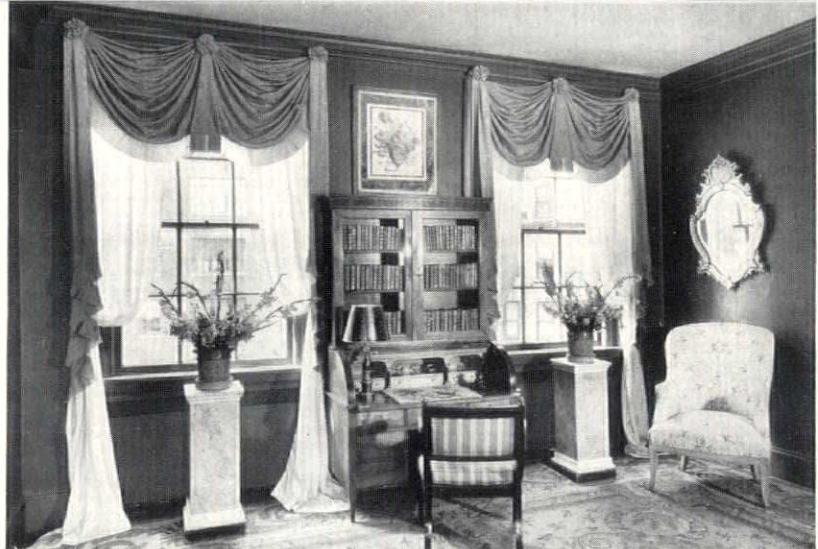

PHOTO: F. S. LINCOLN

W. & J. SLOANE (TOP)

substance is the principle followed today in the manufacture of rayon from spruce pulp and linters, the small fibers that cling to the cotton seed. These are not so much imitation silk, as man-made silk, which like many another synthetic product, is superior, in a number of ways to the original.

Three major processes are used today in the manufacture of rayon. The first, known as the viscose process, is one by which a pulp of wood or cotton linters or both are treated with caustic soda, and then with carbon bisulphide to form cellulose xanthate. A weak solution of caustic soda is then added and after thorough mixing, a viscous liquid is formed which is forced through minute holes in spinnarets that are submerged in an acid bath which coagulates the filaments, producing a hardened thread.

Cotton linters provide the cellulose base in the

second or cuprammonium process. In spinning the filaments, this process follows the others quite closely. The one difference is that the liquid fibers on emerging from the tiny spinnarets through which they are forced, must be passed through a sulphuric acid bath to be hardened.

The third process by which celanese or cellulose acetate is made employs cotton linters which are treated with acetic acid, acetic anhydride and a catalytic agent. In the other two processes chemicals change the physical form but not the chemical composition or qualities of cellulose. In this process an entirely new product is created.

All three types of rayon, though similar, take dyes differently and have slightly different characteristics which are not of great importance to the architect as he usually chooses finished fabrics.

The walls in the Ladies' Lounge, at right, in the Center Theater, Rockefeller Center, New York, are covered with metal cloth in dark brown and silver. The floor covering is Wilton, with white, coral and burgundy ornaments. The chairs are upholstered in horsehair. . . . Below, the drapery material back of beds is white silk satin



PHOTO: F. S. LINCOLN

EUGENE SCHOEN & SONS



PHOTO: MATTIE EDWARDS HEWITT

W. & J. SLOANE

Today Rayon, in all its forms, is of such quality and fineness that often it is difficult to distinguish from the finest silks. Generally speaking, the characteristics of rayon are such that, in its various forms, it is as satisfactory a product for draperies and upholstery as silk.

Fabrics made from rayon are entirely free of weighting and drape in rich, supple folds. Rayon taffetas do not readily split, crack, or flay. Due to the smoothness of the fibers, dust does not cling to

them and decorative fabrics do not readily become soiled. They will not mould or mildew, and dampness does not affect them.

For draperies and glass curtains rayon is woven into ninons, taffetas, permanent moires, satins, velvets, plushes, damask, tapestry, prints, voile, and other fabrics.

Durability, design possibilities and particularly richness of color are among the characteristics of rayon fabrics. Their texture is soft and shimmering. They drape smoothly, do not rot with age and are not harmed by moths. Rayon will not discolor and can easily be washed or dry cleaned.

In combination it gives new beauty to silk, satin and wool because the two fibers may take dyes in different tones. The same thing can be said of the various kinds of rayon which take dyes differently.

Interwoven with cotton, rayon is used to produce a range of practical fabrics notable for their popularity. Moreover, the combination is stronger, for the rayon fiber strengthens cotton in the dry state, whereas cotton strengthens rayon in the wet state. And when interwoven the two fibers soil less easily than does cotton by itself. Worsted fabrics containing rayon are firmer, more interesting and shrink less easily.

## CELLULOSE FABRICS

○ N the market today are a number of fabrics formerly considered to be in the novelty class. These have been developed through the discovery of new materials or manufacturing processes.

For a brief period a few years ago it seemed possible that glass fabrics might assume a place of im-



PHOTO: F. S. LINCOLN

DIANE TATE AND MARION HALL, INC.

The fabric covering the walls in the dining room is Fortuny with a gray background, the design is in silver and gold. The curtains are in gray taffeta. . . . Below, the drapery back of divan is three layers of chiffon, one overhanging the other, in three shades of yellow. The window curtains are of the same material

portance in the field of decoration. Those produced were interesting. But they proved to be impractical, too expensive to manufacture and market. They are, therefore, no longer produced to any extent in this country although they are still made in Germany.

Cellophane has definitely taken its place in the family of fabrics. It is cut from sheet-form into tiny ribbons, varying in width down to one-one hundredth of an inch and is then woven into fabric usually in combination with wool, cotton, silk or rayon.

To prevent draperies from losing their shape the filling threads of another material (those running across the fabric) should be close together. But where sheer fabric is required it is necessary to use Cellophane for the filling threads, with only an occasional use of another filling material to produce the color or design desired. When Cellophane is the base of a drapery fabric, it should run both ways in the weave.

Cellophane can be metallized with aluminum, which does not tarnish quickly. This fact, coupled with the inherent qualities of the material, makes possible effects obtainable with no other fabric.

### TEXTILES FOR WALL COVERINGS

TEXTILE manufacturers have made the interesting observation that decorative trends complete their cycle every twenty-one years. As an illustration—wall covering fabrics are returning to popularity.

The adaptability of glazed chintz for wall covering has already been noted. Rapidly increasing in popularity is a pyroxilin-coated cotton fabric which is available in a wide range of colors. It is strong,



PHOTO: F. S. LINCOLN

SCOTT & TEEGEN

very durable and can be obtained in textures that range from smooth surfaces to reproductions of coarse grained leather.

There are no limitations in the kind of material used for this purpose. The fabric is mounted by pasting, or is stretched and tacked to a frame. In the latter case there is a moulding, top and bottom, and the material may be blind-tacked, or any form of cover mould may be used. If the walls are newly erected and still wet the fabric should be applied



W. H. KRESS

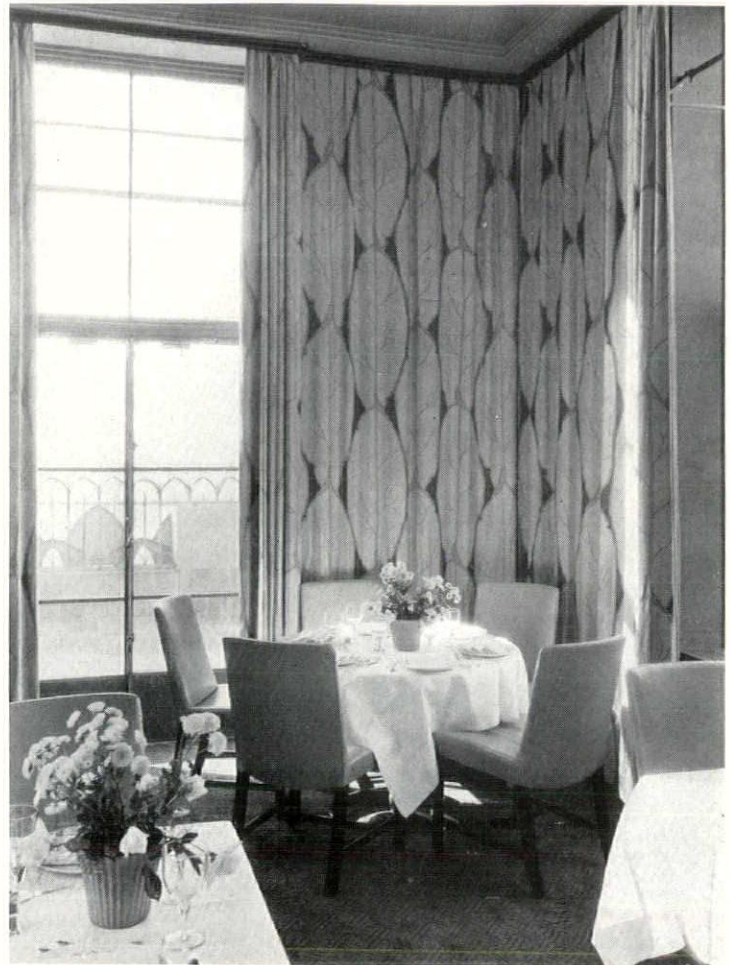

PHOTO: SAMUEL H. GOTTSCHE

The walls of the German boudoir (left) are covered with quilted chintz, with glazed figured chintz used for draperies. . . . In the dining room, at right, the wall draperies are plain weave printed linen, tobacco leaf design in shades of sepia. Eleana B. Schmidt, Decorator

over cotton batting; if comparatively dry, muslin lining should be used; if thoroughly dry, no lining is required.

When fabric is pasted to the wall it should first be sized. However, when stretched and tacked the finished appearance is superior and it is possible to use the material for another purpose at a later time.

Fabrics hung as wall draperies for entire rooms or single walls are coming increasingly into use. Certain acoustical advantages are to be gained in this way and the material may be easily taken down, cleaned and replaced.

The authors wish to acknowledge their indebtedness to the following companies for technical information and advice:

Clarence P. Baxter Co., Bigelow-Sanford Carpet Co., L. C. Chase & Company, The Celanese Corporation, Firth Carpet Company, Floor Covering Advertising Club, Frank D. Maxwell Corp., Mohawk Carpet Mills, Inc., Moss Rose Mfg. Co., Orinoka Mills, F. Schumacher & Co., W. & J. Sloane, DuPont Rayon Co., Inc., International Silk Guild, Inc.



NANCY MCCLELLAND, INC.

The overdraperies in this room are of linen in natural color trimmed with wool fringe, and the curtains are of casement cloth in natural color

# Time-Saver Standards

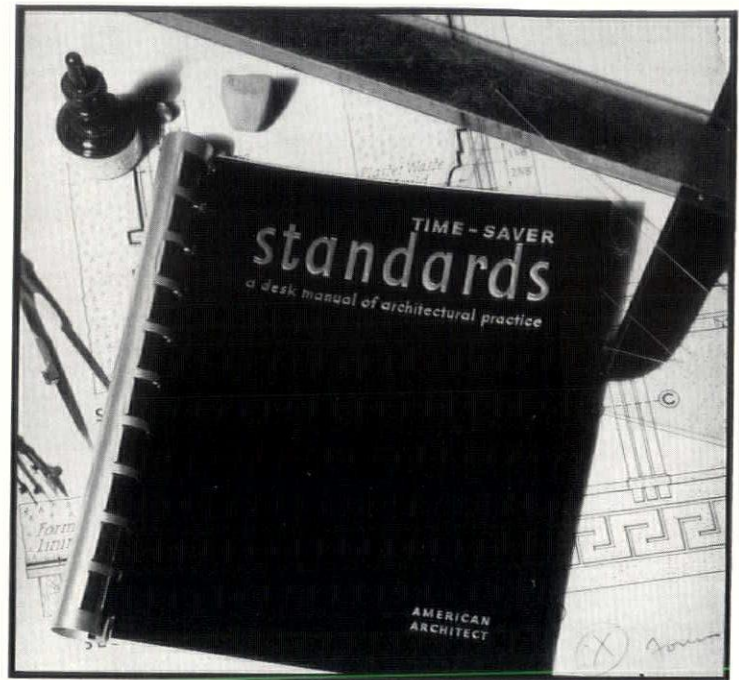

AMERICAN ARCHITECT Time-Saver Standard sheets—simplified technical information on all phases of architectural practice—are available to all active architects, engineers and designers who have registered their application with the Technical Director of American Architect. If you are: 1. A member of an architectural firm or an individual architect in private practice; 2. A consulting or designing engineer actively engaged in building work; 3. A regular employe of an architectural or engineering organization in the capacity of designer, specification writer or "squad boss"; or, 4. A designer, supervising architect or engineer for a financial or educational institution, large property owner or developer—you are eligible to use American Architect Time-Saver Standard sheets to develop your own desk manual of architectural practice.

IN THIS ISSUE . . . Complete Time-Saver Standard Data on SEWAGE DISPOSAL SYSTEMS, including 1. GENERAL DESIGN; 2. SEPTIC TANKS; 3. SLUDGE DRAINS and PITS; 4. LEACHING CESSPOOLS; 5. SUB-SOIL DISPOSAL BEDS; and, 6. SAND FILTERS

# SEWAGE DISPOSAL—1. General Design

TABLE 2. RELATIVE ABSORPTION

Time—1" drop in minutes	Relative Absorption
0—3	Medium
3—5	Rapid
5—30	Slow
30—60	Semi-impervious
60—up	Impervious

For LEACHING CESSPOOLS see Sheet 4  
SUB-SOIL DISPOSAL 5  
SAND FILTERS 6

## PURPOSE

This and the accompanying five sheets on Sewage Disposal enable the architect to design private (or self-contained) sewage disposal systems for residences, camps, summer cottages, schools, factories, hospitals, institutions and the like for any number of occupants up to the equivalent of fifty persons in residences. For larger systems, a sanitation engineer should be consulted.

Past experience, engineering practice and bacteriological research have proven that the old-time sewage cesspool is a menace to health and a nuisance. Sanitation engineers agree that all sewage disposal systems must include a septic tank, wherein sewage is changed by the action of anaerobic bacteria into gases and an effluent liquid, which is then rendered harmless by earth leaching, where aerobic bacteria oxidize all obnoxious components.

## INFLUENCING FACTORS

A complete sewage disposal system, with all essential and optional elements is presented on the next page. The final design of a specific installation is influenced by (1) the amount of sewage handled, which is based on the "Equivalent Occupancy" and (2) the character of the soil as expressed by its "Relative Absorption." Both of these factors can be determined for any project by methods described herein.

## EQUIVALENT OCCUPANCY

The amount of sewage to be handled is related to the type of building and its occupancy. The base is the normal amount of sewage obtained under residential conditions per person per 24 hours. See Table 1. That is, in residential service 50 gallons of sewage per person must be treated each 24 hours. Other types of buildings are related to this base by means of a conversion factor.

**Rule 1.** To find the Equivalent Occupancy in any project, multiply

TABLE 1. EQUIVALENT OCCUPANCY

Type of Building	Gallons per Person	Conversion Factor
Residence	50	1
Camp	25	1/2
Summer Cottages	40	4/5
Day Schools		
Without Showers or Kitchens	15	3/10
Factories		
Without Showers or Kitchens	15	3/10
Day Schools		
With Showers and Kitchens	30	3/5
Institutions		
except Hospitals	100	2
Hospitals	200	4

NOTE: To find Equivalent Occupancy multiply number of persons occupying Type of Building by Conversion Factor.

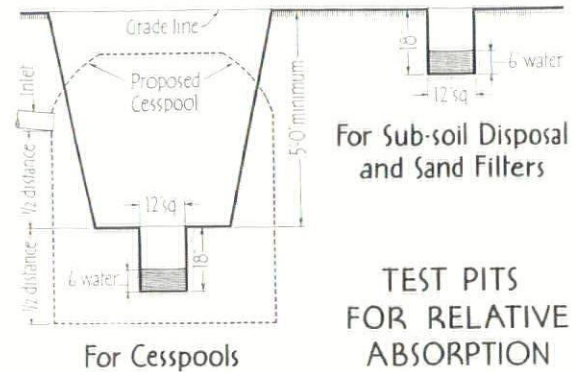

the number of persons occupying the type of building by the conversion factor given in Table 1.

Equivalent Occupancy governs the size of the septic tank and of course also influences the capacity required in the effluent disposal system. For convenience Table 1 is repeated on each sheet where Equivalent Occupancy is a factor in design.

## RELATIVE ABSORPTION

The porosity or absorption of the soil is a vital factor in design. A simple field method of determining the characteristics of any soil in relation to effluent disposal consists of digging a pit of fixed dimensions and measuring the rate of outflow of water from the pit.

The depth below grade of this test pit varies according to the unit under consideration, as developed in detail on Sheets 4, 5 and 6. The size of the pit in which the water test is made is always 12 inches square and 18 inches deep as illustrated above. Water to the depth of 6 inches (about 3 3/4 gallons) is poured quickly into this square test pit and the time required for the water to disappear is measured and one-sixth of this time is taken as the average time for the water level to fall 1 inch. This latter time is the Relative Absorption factor for the soil but for convenience is expressed as rapid, medium, slow, semi-impervious and impervious as indicated in Table 2.

## DESIGN PROCEDURE

A tentative layout of the proposed sewage disposal system, similar to the diagrammatic plan on this sheet, should be made over a topographic plot plan of the property. Test pits should be dug at the sites of any proposed leaching cesspool or other effluent disposal area as detailed on this sheet and the Relative Absorption determined.

With these data and the Equivalent Occupancy known (as per Rule 1) reference should be made to Table 3 to select the type of effluent disposal system best adapted to project conditions.

TABLE 3. SELECTION OF EFFLUENT SEWAGE DISPOSAL SYSTEM

CONDITIONS	TYPE OF DISPOSAL SYSTEM		
	Leaching Cesspool	Sub-soil Drainage	Sand Filter
RELATIVE ABSORPTION:			
Rapid	YES	YES	NO
Medium	YES	YES	NO
Slow	YES	YES	NO
Semi-impervious	NO	YES	NO
Impervious	NO	NO	YES
AVAILABLE AREA:			
Large	YES	YES	YES
Moderate	YES	YES	YES
Small	YES	NO	NO
GROUND WATER: Below Grade	8'0" minimum	2'0" minimum Only required for semi-impervious soils	4'0" minimum
FINAL DISPOSAL OF EFFLUENT	Not Necessary		Always Necessary
RELATIVE INITIAL COST	LOW	MEDIUM	HIGH



**SEWAGE DISPOSAL—1. General Design** Serial No. 17 NOVEMBER 1935

**ELEMENTS OF SEWAGE DISPOSAL SYSTEMS**

**HOUSE SEWER . . .** Extends from House Main to septic tank. The "house main" is a continuation of the cast iron soil line to a minimum of 5 feet outside of foundation. No trap or fresh air inlet is required in the house main. The house sewer may be solid glazed clay tile, cement bell and spigot pipe, or preferably cast-iron pipe, laid with filled joints. Always use cast-iron within 100 feet of any potable water supply and near trees. Never connect surface drainage lines to sewage disposal system.

Requirements: Size: 6" preferable, minimum 4". Pitch: 1" in 8 feet for 6" pipe; 1" in 4 feet for 4" pipe. Grade: northern latitudes 1'6" minimum below surface; southern latitudes, sufficient depth to cover.

**Grease Bearing Waste and Trap.** Optional elements, used to separate grease and oil from waste. For specific recommendations see Sheet 3. When installed run from grease-carrying waste in building through trap to house sewer.

**SEPTIC TANK . . .** This is the essential element of a sanitary disposal system. Locate as far to leeward of building as possible.

Its function is to retain the raw sewage out of contact with air until anaerobic bacteria can break down the solids into gases which escape through vents and an effluent liquid which is subsequently purified by oxidation. Some solids settle as sludge. Construction and operating details are given on Sheet 2.

**Siphon Tank.** Required in large installations and when sand filter is used; desirable but not essential with small septic tanks. It functions to collect effluent from the septic tank and periodically discharge it to the effluent disposal system. For details see Sheet 2.

**Sludge Drain and Pit.** These elements are optional, and serve to draw sludge from septic tank without interrupting its operation for cleaning. Drain is similar in construction to house sewer. For details see Sheet 3.

**EFFLUENT DISPOSAL . . .** There are three principal types of effluent disposal systems, between which choice is governed by soil conditions and topography. All are designed to permit the effluent to come in contact with air and soil where it may be oxidized and rendered harmless by aerobic bacteria.

**Effluent Sewer.** This element is common to all systems and is a closed sewerage line similar in construction and size to the house sewer, extending from the septic or siphon tank through a distribution box or gate to the chosen type of effluent disposal element. Minimum pitch may be 1" in 16 ft.

**Distribution Box or Gate.** This device serves to distribute the effluent to one part or another of the effluent disposal system in order to "rest" the part not in use. Details are given on Sheet 3.

**Choice of Effluent Disposal** system is governed by factors included in Tables 1 and 2 of this sheet. Selection is determined from Table 3 and from the following:

- Leaching Cesspool. See Sheet 4.
- Sub-Soil Disposal. See Sheet 5.
- Sand Filter. See Sheet 6.

All data in this series of six Time-Saver Standards have been prepared by the Technical Service Staff from data collected exclusively for American Architect by Ralph Eberlin, C.E., and Harold R. Sleeper, A.I.A.

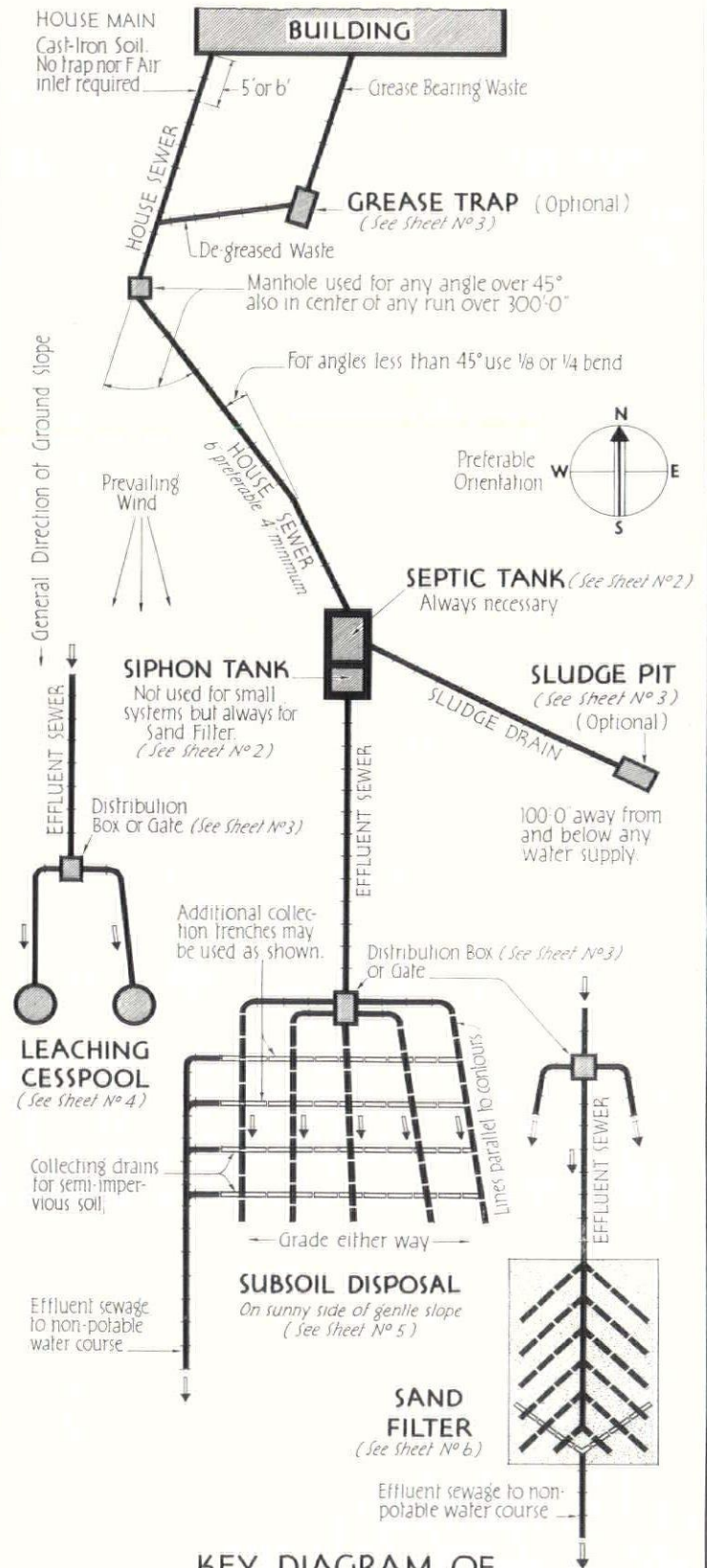

**KEY DIAGRAM OF SEWAGE DISPOSAL SYSTEM**

TABLE 1—EQUIVALENT OCCUPANCY

Type of Building	Gallons per Person	Conversion Factor
Residence	50	1
Camp	25	1/2
Summer Cottages	40	4/5
Day Schools Without showers or kitchens	15	3/10
Factories Without showers or kitchens	15	3/10
Day Schools With showers and kitchens	30	3/5
Institutions Except Hospitals	100	2
Hospitals	200	4

**PURPOSE**

This is the second sheet in a series of six relating to the complete design of private (or self-contained) sewage disposal systems for residences and other buildings having any number of occupants up to the equivalent of 50 persons in residences.

The septic and siphon tanks here detailed are of reinforced concrete construction and can be constructed by any competent contractor without requiring the use of any patented or manufactured element other than the automatic siphon which is an essential part of a siphon tank. Septic tanks, however, are made in commercial units and available in all parts of the country. They are of steel, precast concrete and other materials. The use of commercial septic and siphon tanks eliminates the need for detailed design of these units as presented herewith, but the selection of the proper size of a commercial unit is also indicated by the data presented herewith.

**OPERATION**

Raw sewage from the house sewer enters the septic tank where, by means of a submerged intake, it reaches the liquid in the tank below the overflow level. The liquid in the septic tank quickly forms three distinct layers or strata; solid matter or sludge settles to the bottom, effluent sewage forms the main liquid content in the middle, and the upper stratum is a scum which serves to keep air out of contact with the effluent sewage and permits anaerobic bacterial action or septicization to take place. Most of the suspended solid matter is changed by this action into (1) gases which escape through vents provided for the purpose, and (2) effluent sewage which overflows either directly or through the siphon tank into the effluent sewer and then to the effluent disposal system.

The sludge which forms at the bottom of the septic tank must be periodically removed to avoid filling the tank with solid matter. In large installations where interruption of the operation of the septic tank for cleaning purposes is undesirable, a sludge drain and sludge pit should be provided to permit removal of sludge while the tank is in continuous operation. Layout of sludge drain and pit is covered in Sheet 1 and the design of these elements is described in Sheet 3 of this series.

Whenever an effluent disposal system of sand filter type is used, when the system is designed for 1000 gallons or more daily capacity, and preferably in all residences, the septic tank should be equipped with a siphon tank. The latter unit, however, is not actually required in small installations using leaching cesspools or sub-soil disposal beds.

The siphon tank functions to collect overflow from the septic tank and discharge it periodically through the action of the automatic siphon into the effluent sewer and disposal system. This permits the disposal units to absorb the effluent intermittently, and prevents saturation of the disposal beds.

**DESIGN**

The size of a septic tank, and therefore the size of its related siphon tank, is governed wholly by the number of gallons of sewage to be treated per 24 hours. This can be determined from the data relating to equivalent occupancy given on Sheet 1, which is repeated here for convenience.

**Rule 1.** To find the equivalent occupancy in any project, multiply the number of persons occupying the type of building by the conversion factor given in Table 1.

**Rule 2.** To find the dimensions and construction details for any reinforced concrete septic tank and siphon tank as detailed on the accompanying drawings, refer to Table 2 and find in the first column the equivalent occupancy nearest to that calculated for the project. Read horizontally to the right for all dimensions not given directly on the drawings.

**Rule 3.** To find the capacity of any commercial septic tank proceed as in Rule 2 but find in Table 2 the capacity in gallons (second column) which corresponds to the equivalent occupancy of the project (column 1) and select a unit guaranteed by the manufacturer to treat that quantity of sewage per 24 hours. The siphon tank adapted to the manufactured septic tank will be indicated by the manufacturer's own data.

**LOCATION**

When a septic tank is equipped with a sludge drain and pit the septic tank can be buried and its manhole cover identified merely by the position of the protruding vent or vents. However, the manhole for access to the sludge drain gate valve should be carried near to the surface so that it can be exposed conveniently for operating the valve. When no sludge drain and pit are provided the septic tank should be so located that the covering earth may be periodically removed without disfiguring the property. The same precautions also pertain to the manhole cover for the siphon tank.

**MAINTENANCE DATA**

The owner of a septic tank should be provided by the designer with a written memorandum containing the following data: (1) A plan indicating the exact location of the septic and siphon tank manholes (and sludge drain gate valve manhole when used). (2) Advise inspection of the septic tank each spring and fall by removing the vent caps and testing the depth of the sludge by means of a rod or plumb-bob. Also during severe weather periodically examine the vents to see that excess flowing on the interior has not obstructed their operation. (3) Whenever the sludge level appears to reach the low end of the intake or discharge pipes, or in the event of any signs of flooding, immediately clean out the septic tank (or draw off the sludge to the sludge pit). (4) Whenever the siphon tank requires cleaning, it is also advisable to remove the manhole cover of the siphon tank and inspect and clean the automatic siphon.

**SEWAGE DISPOSAL—2. Septic & Siphon Tanks** Serial No. 18 **NOVEMBER 1935**

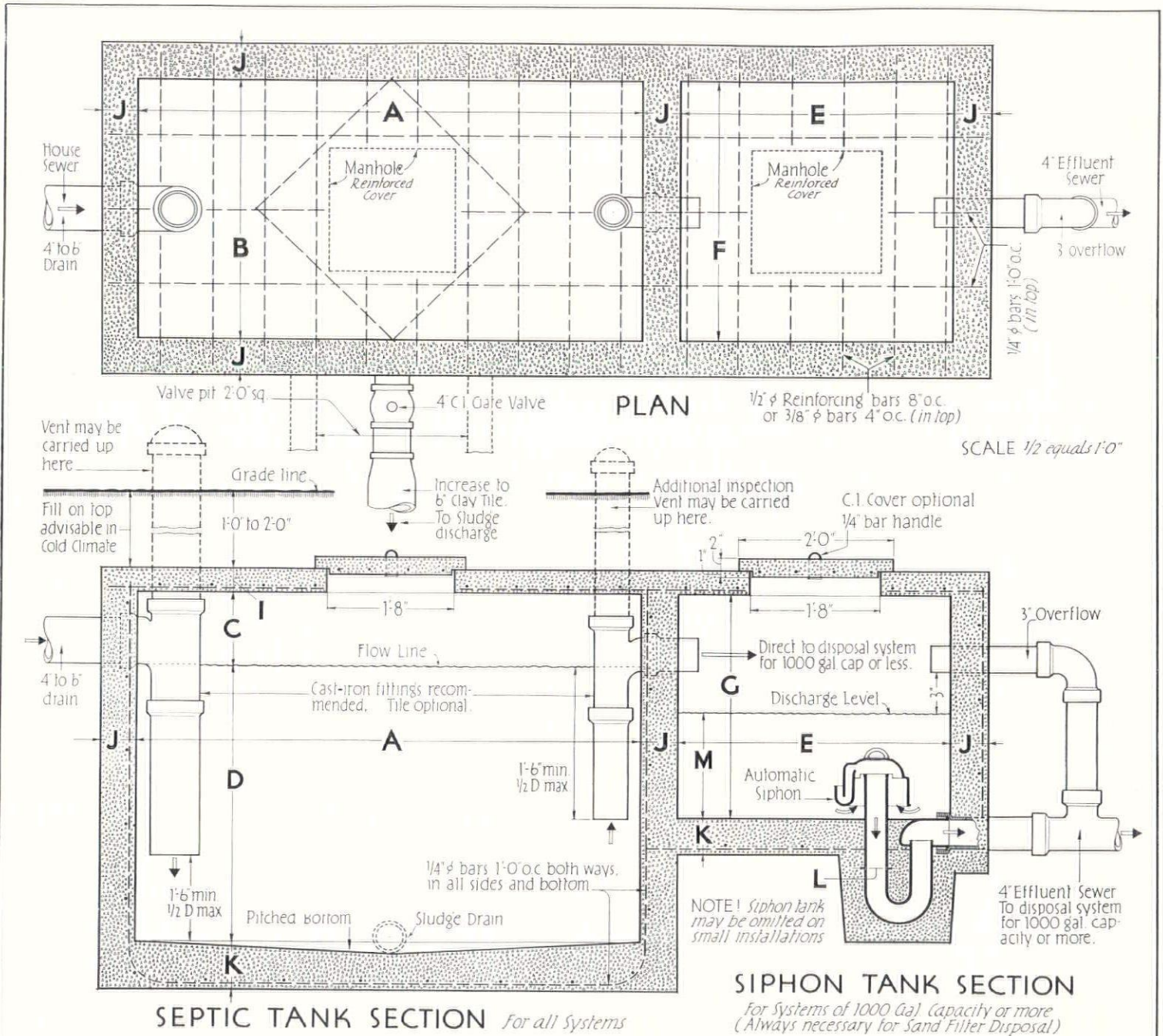

TABLE 2—SEPTIC AND SIPHON TANKS, SELECTION AND DESIGN

Equivalent Occupancy	SEPTIC TANK					SIPHON TANK			SIPHON		CONCRETE THICKNESS		
	Cap. in Gals.	Length A	Width B	Air Space C	Liquid Depth D	Length E	Width F	Depth G	Size L	Drawing Depth M	Walls J	Top I	Bottom K
1-4	*325	5'-0"	2'-6"	1'-0"	3'-6"	**							
5-9	450	6'-0"	2'-6"	1'-0"	4'-0"	**3'-0"	**2'-6"	**3'-0"	3"	1'-6"	6"	4"	6"
10-14	720	7'-0"	3'-6"	1'-0"	4'-0"	**3'-6"	**3'-6"	**3'-0"	3"	1'-6"	6"	4"	6"
15-20	1000	8'-0"	4'-0"	1'-0"	4'-0"	4'-0"	4'-0"	3'-0"	4"	1'-8"	6"	4"	6"
21-25	1250	9'-0"	4'-6"	1'-0"	4'-3"	4'-6"	4'-6"	3'-0"	4"	1'-8"	7"	5"	6"
26-30	1480	9'-6"	4'-8"	1'-3"	4'-6"	4'-8"	4'-8"	3'-6"	4"	2'-2"	8"	5"	6"
31-35	1720	10'-0"	5'-0"	1'-3"	4'-8"	5'-0"	5'-0"	3'-6"	4"	2'-2"	8"	5"	6"
36-40	1950	10'-6"	5'-3"	1'-3"	4'-9"	5'-3"	5'-3"	3'-6"	4"	2'-2"	9"	5"	6"
41-45	2175	11'-0"	5'-6"	1'-3"	4'-10"	5'-6"	5'-6"	3'-6"	5"	2'-2"	9"	5"	6"
46-50	2400	11'-6"	5'-9"	1'-3"	5'-0"	5'-9"	5'-9"	3'-6"	5"	2'-2"	9"	5"	6"

Capacity of tanks based on 50 gallons per Equivalent Occupancy per 24 hours. \*Smallest size recommended.  
\*\*Siphon Tank not essential for Septic Tanks under 1000 gallons capacity. Rarely used on smallest size.

TABLE 1—SLUDGE PIT DIMENSIONS

Equivalent Occupancy	Cap. in Gallons	Length A	Width B	Air Space C	Liquid Depth D
1- 4	325	5'-0"	2'-6"	1'-0"	3'-6"
5- 9	450	6'-0"	2'-6"	1'-0"	4'-0"
10-14	720	7'-0"	3'-6"	1'-0"	4'-0"
15-20	1000	8'-0"	4'-0"	1'-0"	4'-0"
21-25	1250	9'-0"	4'-6"	1'-0"	4'-3"
26-30	1480	9'-6"	4'-8"	1'-3"	4'-6"
31-35	1720	10'-0"	5'-0"	1'-3"	4'-8"
36-40	1950	10'-6"	5'-3"	1'-3"	4'-9"
41-45	2175	11'-0"	5'-6"	1'-3"	4'-10"
46-50	2400	11'-6"	5'-9"	1'-3"	5'-0"

Sludge pits should be of the same capacity as the septic tanks they serve.

## PURPOSE

This is the third of a series of six sheets relating to the design of private (or self-contained) sewage disposal systems in residences and other small buildings for any number of occupants up to the equivalent of 50 persons in residences. This sheet provides data for the design of 3 types of units: grease traps, sludge pits and distribution boxes. Of these, grease traps and sludge pits are optional units which may or may not be required by the system, according to the conditions defined in Sheet 1 of this series. Distribution boxes are required in practically all systems.

## GREASE TRAPS

The function of a grease trap is to separate grease and oil from kitchen, laundry and other specialized wastes and to prevent it from entering the sewage disposal system. Grease and oil may interfere with the formation of a proper scum in the septic tank and may clog or reduce the porosity of leaching cesspools, sub-soil disposal beds, or sand filters. The use of a grease trap is therefore recommended in the majority of installations, but is not a mandatory requirement of small installations where no great quantity of grease or oil occurs.

The grease traps here detailed are of concrete construction for use outside the house. Such a unit is not required where a metal grease trap is installed indoors in waste lines carrying grease or oil. These indoor traps offer greater convenience for cleaning, and may be used in small or medium sized projects, if the odor arising during their cleaning operation is not a serious objection.

Complete design data are contained in the accompanying drawings. The size of the grease trap does not vary materially with the size of the building it serves; however, when the quantity of waste causes rapid flow it is advisable to use a rectangular trap with baffle.

Owners should be advised to clean grease traps frequently;

therefore, trap should be located at a point where the loose earth over the cover may be removed and replaced without impairing the appearance of the property. Within reason, the grease trap should be located as far as possible from the building and to the leeward to minimize objections to the odor which always follows a grease trap cleaning operation.

## SLUDGE PITS

As is indicated on Sheet 2 of this series the use of a sludge pit depends upon the need for cleaning septic tanks without interrupting their operation. The location of a sludge pit is indicated on Sheet 1 of this series.

Since the size of a sludge pit must be such that it has a capacity equivalent to the septic tank it serves, refer to Sheet 2 for methods of determining the size required, and to Table 1 on this sheet for all dimensions not shown directly in the accompanying drawings.

## DISTRIBUTION BOXES

The location and general use of distribution boxes is indicated in the general design diagrams in Sheet 1 of this series, and in each of the following sheets (Nos. 4, 5 and 6) relating to effluent disposal methods.

They function to control and direct the flow of effluent sewage from the effluent sewage main to various parts of the effluent disposal system, permitting part of that system to enter while another part, or parts is functioning.

The type of distribution box varies according to the number of outlets and the manner in which the flow must be controlled. It should be noted that in every installation the distribution box should be designed to provide one or more additional outlets than is contemplated in the initial installation to facilitate the extension, removal or re-location of the effluent disposal units. Complete design data for concrete distribution boxes are contained in the accompanying drawings.

**SEWAGE DISPOSAL—3. Distribution Boxes, etc.** Serial No. 19 NOVEMBER 1935

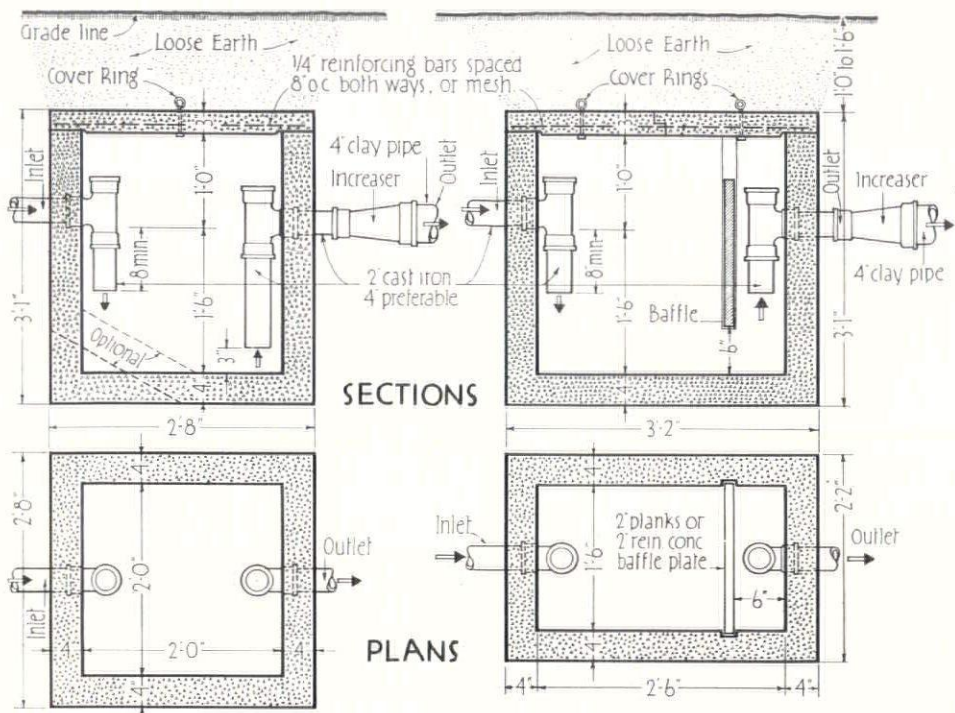

**Square Type without Baffle**      **Rectangular Type with Baffle**  
*Cast Iron Connections shown but these may be Clay Tile for economy.*

**GREASE TRAPS**      *Scale 1/2"=1'-0"*

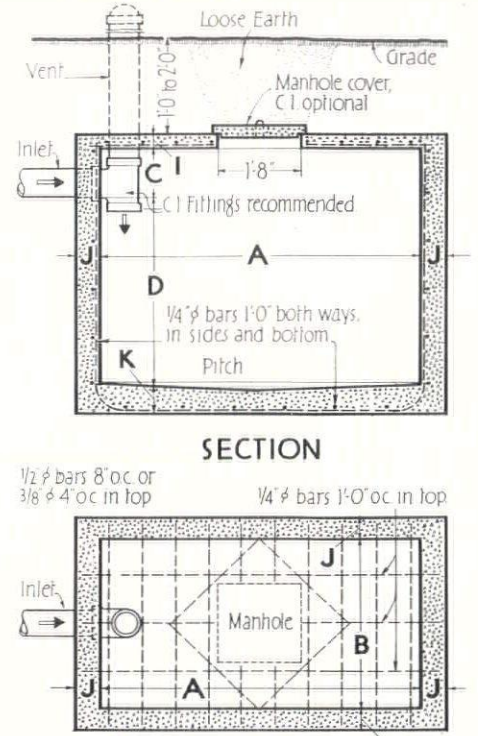

**SECTION**

**PLAN**  
*Scale 1/4"=1'-0"*

**SLUDGE PIT**

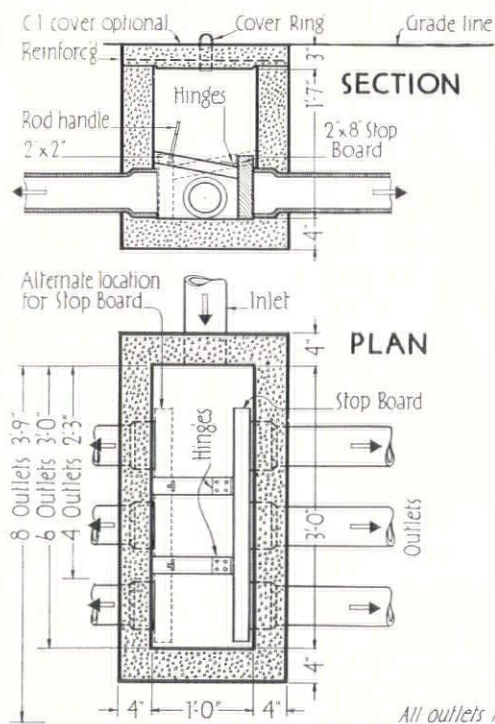

**Box for 4 or more Outlets**

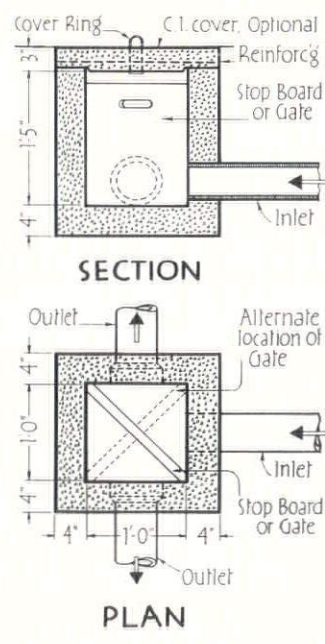

**Box for 2 Outlets**

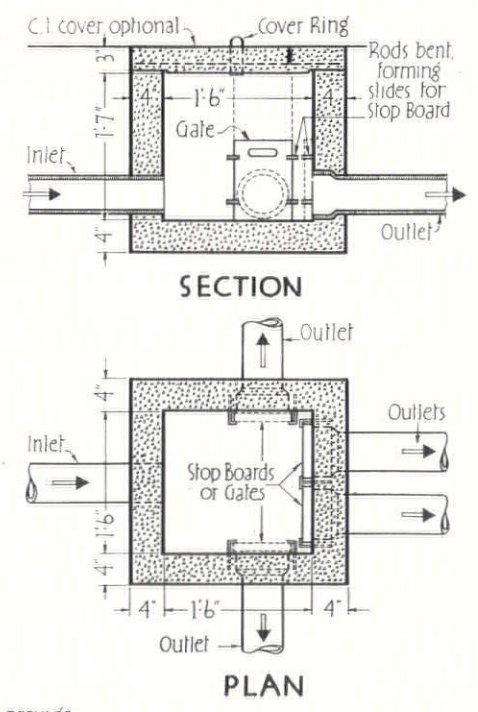

**Box for 4 Outlets**

*All outlets must be set exactly level. Stop boards are used to provide a rest period for a part of the disposal field. Always used for filter beds and recommended for all but very small installations of all types*

**DISTRIBUTION BOXES**

*Scale 1/2"=1'-0"*

# SEWAGE DISPOSAL—4. Leaching Cesspools

## PURPOSE

This is the fourth sheet in a series of six on design of private (or self-contained) sewage disposal systems for residences and other minor buildings for any number of occupants up to the equivalent of 50 persons in residences. This sheet gives complete design data on leaching cesspools which constitute one of three types of effluent disposal methods from which the designer may choose. The choice is governed largely by soil conditions and the amount of land area available as defined in detail on Sheet 1 of this series.

## APPLICATION

Advantages of the leaching cesspool are: It requires a minimum of land area, it can be used on a site of any slope, it is low in initial cost, and it seldom requires cleaning at more frequent periods than about two years. It can be used in all reasonably absorptive soils.

Limitations on its use are these: The leaching cesspool can never be used in a soil rated as semi-impervious or impervious, it requires a location where the normal ground water level is at least 8 feet below grade or 2 feet below the bottom of the cesspool, it should never be located within 100 feet or more of a potable water supply, and it should be situated at least 15 feet from the building it serves.

Leaching cesspools are limited in capacity; hence several units may be required to handle the effluent from large septic tanks. The spacing and therefore the land area required by multiple leaching cesspools is indicated on the accompanying diagrams. It is recommended that when two or more cesspools are used at least the first pair be connected through a distribution box for alternate operation rather than be installed in tandem. When more than two are employed tandem operation is permissible for the first pair, as then the more remote cesspool takes the overflow of the nearer unit when loads are heavy.

## OPERATION

Leaching cesspools receive the effluent sewage from the septic tank or siphon tank and allow the liquor to be absorbed by the surrounding porous earth. Walls of the pool are laid up below the inlet with open seepage joints to allow the liquor to pass through these joints to a surrounding layer of broken stone and thence to the earth. The bottom of the pool is also an absorptive surface. All masonry above the inlet should be laid with tight mortar joints to minimize the entrance of surface water as well as for structural strength.

TABLE 1—EQUIVALENT OCCUPANCY

Type of Building	Gallons per Person	Conversion Factor
Residence	50	1
Camp	25	1/2
Summer Cottages	40	4/5
Day Schools Without showers or kitchens	15	3/10
Factories Without showers or kitchens	15	3/10
Day Schools With showers and kitchens	30	3/5
Institutions Except Hospitals	100	2
Hospitals	200	4

TABLE 2—RELATIVE ABSORPTION

Time—1" Drop in Minutes	Relative Absorption
0- 3	Rapid
3- 5	Medium
5-30	Slow
30-60	Semi-impervious Do not use Leaching Cesspools
60-up	Impervious Do not use Leaching Cesspools

## DESIGN

To determine the size and number of leaching cesspools required by any project, it is first necessary to determine the Equivalent Occupancy (which governs the amount of effluent to be treated) and the Relative Absorption of the soil (which influences the capacity of the individual units). Methods of determining these two factors are given on Sheet 1 of this series in general terms, but are repeated here for convenience.

**Rule 1.** To find the Equivalent Occupancy in any project, multiply the number of persons occupying the type of building by the conversion factor given in Table 1.

**Rule 2.** To find the Relative Absorption of the soil at the site of any leaching cesspool: Excavate a test pit at the site selected for the cesspool to a depth approximately half the distance from the inlet level to the bottom of the proposed cesspool but never less than 5 feet below grade. Make this pit large enough to work in conveniently. At the bottom of this pit carefully excavate a rectangular pit 12 inches square and 18 inches deep. Pour water into this small pit as quickly as possible, to a depth of 6 inches (requiring approximately 3¾ gallons). Note the time required for this 6 inches of water to be absorbed, and take 1/6 of this time as the average time for the water to fall 1 inch. Refer to Table 2 and find the Relative Absorption as rapid, medium or slow. If the rate of absorption exceeds 30 minutes, the site is not suitable for leaching cesspools.

**Rule 3.** To find the dimensions of any cesspool and the number of cesspools required for a given Equivalent Occupancy and determined Relative Absorption, refer to Table 3 and the accompanying drawing. Note that the table is divided into three parts according to the type of soils and that in each part the first column indicates the number of cesspools required.

# SEWAGE DISPOSAL—4. Leaching Cesspools

Serial No. 20 NOVEMBER 1935

Keep Cesspools at least 100'-0" away and on down grade from any water supply.

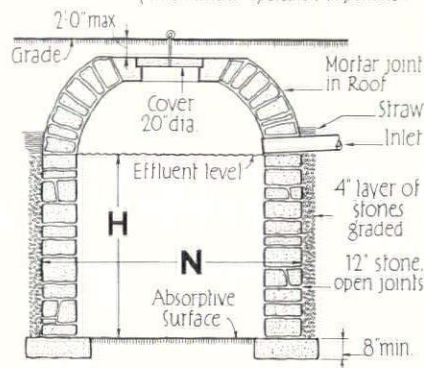
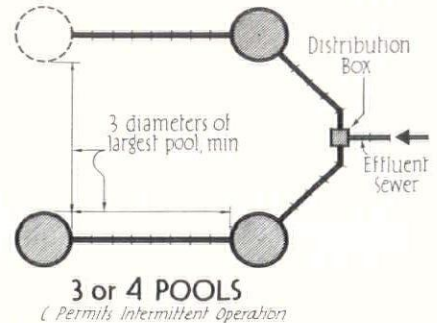
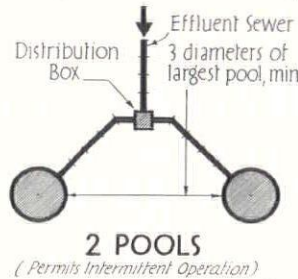
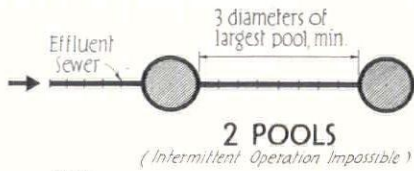
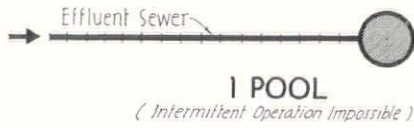

Section

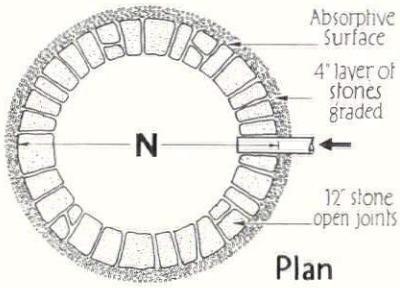

12" STONE

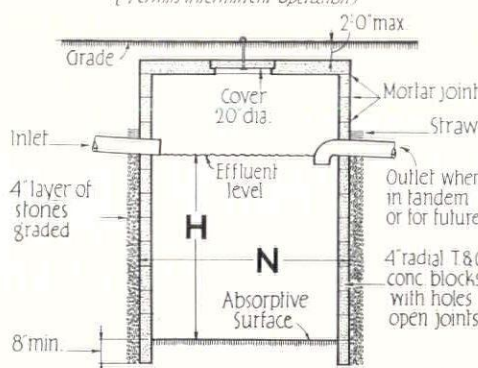

Section

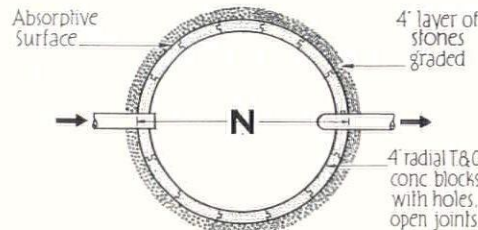

4" RADIAL CONCRETE BLOCKS

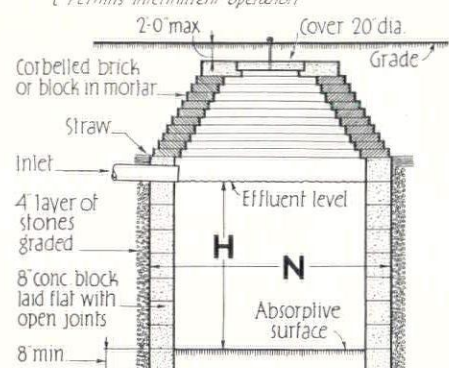

Section

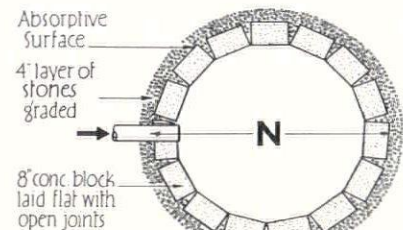

8" CONCRETE BLOCK

TABLE 3—LEACHING CESSPOOLS, SELECTION AND DESIGN

Equivalent Occupancy	RELATIVE ABSORPTION											
	RAPID ABSORPTION COARSE SAND OR GRAVEL				MEDIUM ABSORPTION FINE SAND OR SANDY LOAM				SLOW ABSORPTION CLAY WITH SAND OR LOAM			
	No. of Cess-pools	Dia. N	Depth H	Absorptive Area per Person (Sq. Ft.)	No. of Cess-pools	Dia. N	Depth H	Absorptive Area per Person (Sq. Ft.)	No. of Cess-pools	Dia. N	Depth H	Absorptive Area per Person (Sq. Ft.)
1-4	1	5'	5'	24.5	1	6'	6'	35.0	2	5'	5'	49.0
5-9	1	6'	6'	15.7	2	6'	6'	31.3	2	8'	7'	48.0
10-14	1	8'	6'	14.4	2	8'	6'	28.7	2	10'	8'	46.7
15-20	2	6'	6'	14.1	2	9'	7'	26.14	3	10'	8'	49.5
21-25	2	7'	6'	13.6	2	10'	8'	27.1	4	9'	8'	46.4
26-30	2	8'	6'	13.4	3	9'	7'	26.14	4	10'	8'	43.6
31-35	{ 1 1	{ 8' 9'	{ 7' 7'	13.6	{ 1 2	{ 9' 10'	{ 7' 8'	26.1	5	10'	8'	46.7
36-40	{ 1 1	{ 9' 9'	{ 7' 8'	13.7	4	9'	7'	26.1	4	12'	10'	48.9
41-45	3	8'	6'	13.4	4	9'	8'	25.7	5	12'	10'	54.3
46-50	2	10'	8'	13.0	4	10'	8'	26.1	5	12'	10'	48.9

# SEWAGE DISPOSAL—5. Sub-soil Disposal Beds

## PURPOSE

This is the fifth sheet in a series of six on the design of private (or self-contained) sewage disposal systems for residences and other buildings having any number of occupants up to the equivalent of 50 persons in residences. This sheet covers the design of sub-soil disposal beds which represent one of three methods for disposing of liquid effluent after it leaves the septic tank or siphon tank.

## APPLICATION

Advantages of the sub-soil disposal bed as compared to leaching cesspools or sand filters are: It may be used in any soil except that rated as impervious. When used in soils rated as rapid, medium or slow, distribution drains only are required; but when used in soils rated as semi-impervious, both distribution and collection drains are needed, and the filtered effluent sewage from the collection drains must be disposed to more absorptive soil or to a non-potable water course. These beds may be located on ground that is level or slightly sloping; occasionally on relatively steep slopes by proper arrangement of drainage lines, and they require little or no cleaning if the septic tank is kept in good operating condition. When possible the disposal beds should be placed on a southern slope.

Limitations on the use of this method are: Ground water should be more than 2 ft. below grade. The initial cost of sub-soil disposal beds is usually greater than the cost of leaching cesspools, though less than that of sand filters. The amount of land area required is greater than for either cesspools or sand filters.

## OPERATION

Sub-soil disposal beds consist of a series of drain lines laid with tight joints where slopes are relatively steep, leading to continuations of these lines laid with open joints through which the effluent sewage filters into the surrounding soil. The open joint lines are laid at slopes ranging from 1 inch in 24 ft. to 1 inch in 32 ft., and therefore usually follow the contour lines. The arrangement of lines shown in the accompanying drawings are purely diagrammatic.

## DESIGN

Capacity of a sub-soil disposal bed is governed by the number of lineal feet of 4-inch drainage lines laid with open joints. Note that drain lines laid with tight joints for purposes of effecting proper separation of the seepage lines are not counted in com-

puting the capacity of the bed. Capacity, of course, is related to both the equivalent occupancy upon which the entire system is designed and to the relative absorption of the soil. Methods of determining these factors are covered in Sheet 1 but are repeated here for convenience.

**Rule 1.** To find the equivalent occupancy in any project, multiply the number of persons occupying the type of building by the conversion factor given in Table 1.

**Rule 2.** To determine the relative absorption proceed as follows: At the site of the proposed bed excavate a rectangular pit 12 inches square and 18 inches deep below the finished surface grade of that area, shaping the sides for accurate measurements as carefully as possible. Into this pit quickly pour water to the depth of 6 inches (requiring approximately 3¾ gallons) and measure the time required for the water to be completely absorbed by the soil. Take ¼th of this time as the average time required for the soil to absorb 1 inch. Refer to Table 2 and find the relative absorption as rapid, medium, slow or semi-impervious. If the time for a 1-inch drop exceeds 60 minutes, sub-soil disposal beds should not be used. If the time for a 1-inch drop is from 30 to 60 minutes, design the bed with collection drains as indicated in the accompanying drawings and carry the collection line to a non-potable water course or to a cesspool or a second disposal bed in a more absorptive soil.

**Rule 3.** To determine the lineal feet of 4-inch open joint tile drain required for any equivalent occupancy and for any relative absorption up to impervious soils, refer to Table 3 and find in the first column the equivalent occupancy figure nearest to that determined for the project. Read to the right for the lineal feet of 4-inch open joint drain tile in the column representing the relative absorption of the soil as determined by the preceding test. Note that the same lineal feet of tile is used for soils of slow absorption and those rated as semi-impervious, the difference in systems being reflected in the use of collection drains in semi-impervious soils.

## METHOD OF LAYING TILE

Complete data on the layout of sub-soil disposal drains are contained in the accompanying drawing which also shows accepted methods for protecting the open joints between tiles. A suggestion is indicated for using stakes and boards for accurately aligning the slope of drainage lines. Choice between various types of drainage lines is governed largely by their local availability and cost, and ease of laying under project conditions.

Type of Building	Gallons per Person	Conversion Factor
Residence	50	1
Camp	25	1/2
Summer Cottages	40	4/5
Day Schools without showers or kitchens	15	3/10
Factories without showers or kitchens	15	3/10
Day Schools with showers and kitchens	30	3/5
Institutions except Hospitals	100	2
Hospitals	200	4

Time—1" drop in minutes	Relative Absorption
0- 3	Rapid
3- 5	Medium
5-30	Slow
30-60	Semi-impervious Use Collection Drains
60-up	Impervious Do not use Sub-soil disposal

Equivalent Occupancy	RELATIVE ABSORPTION		
	RAPID Coarse Sand or Gravel	MEDIUM Fine Sand or Sandy Loam	SLOW or SEMI-IMPERVIOUS Clay with Sand or Loam
	Lineal Feet of 4" Open Joint Tile Drain Required		
1- 4	100	150	250
5- 9	200	350	700
10-14	340	500	1000
15-20	475	650	1250
21-25	600	800	1500
26-30	725	1025	1800
31-35	850	1150	2100
36-40	975	1300	2400
41-45	1100	1450	2700
46-50	1200	1600	3000



# SEWAGE DISPOSAL—5. Sub-soil Disposal Beds

Serial No. 21 NOVEMBER 1935

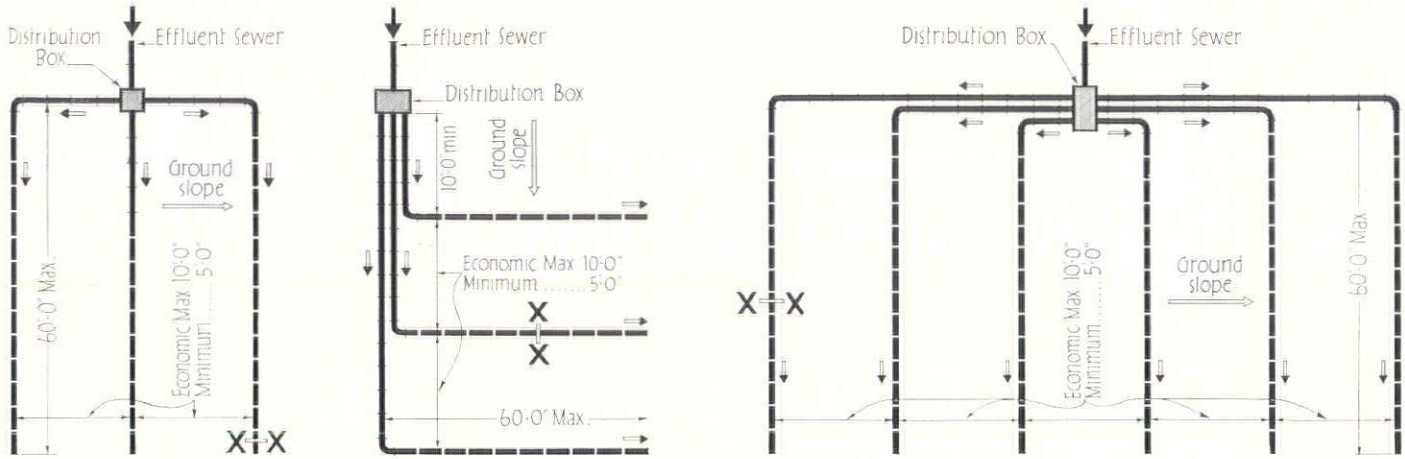

SUB-SOIL DISPOSAL FIELD DRAINS FOR FLAT OR SLIGHTLY SLOPING GRADES

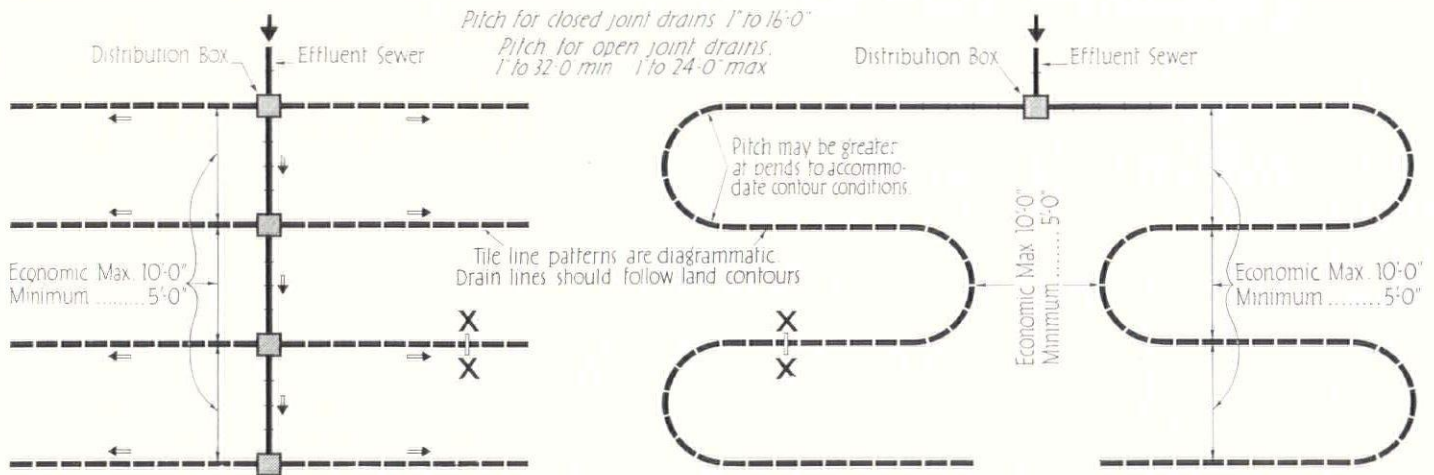

SUB-SOIL DISPOSAL FIELD DRAINS FOR STEEP GRADES

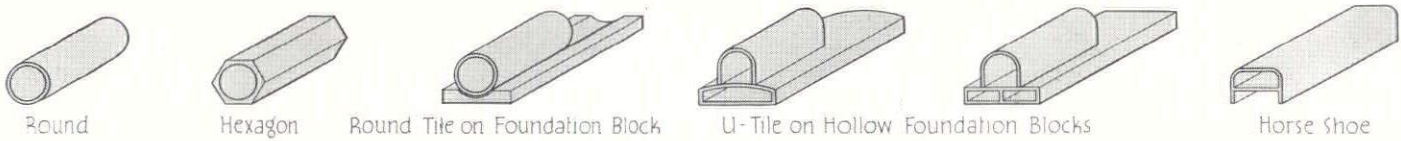

## TYPES OF DRAINAGE TILES

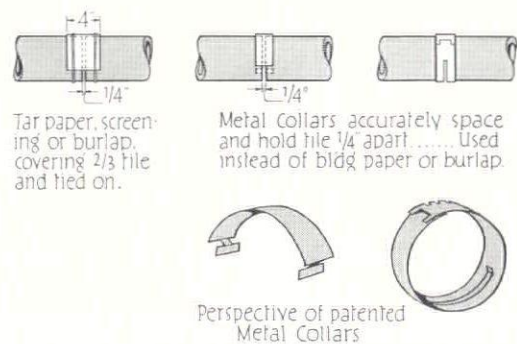
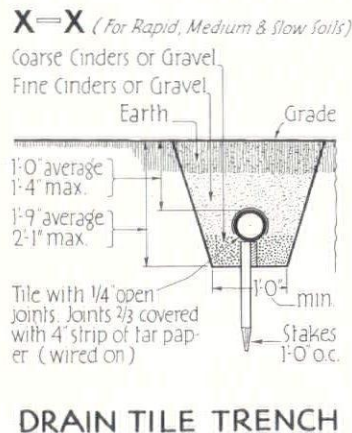
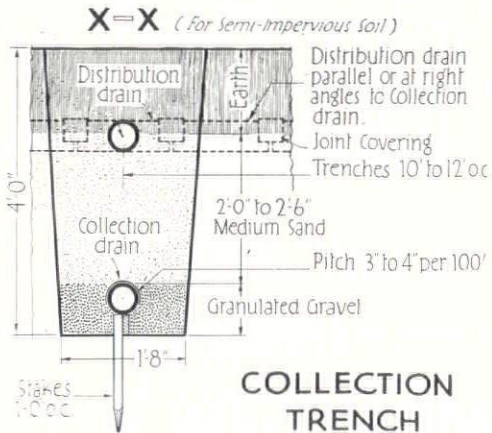

## PURPOSE

This is the last sheet in a series of six on the design of private (or self-contained) sewage disposal systems for residences or other minor buildings for any number of occupants up to the equivalent of 50 persons in residences. This sheet gives complete design data on sand filters, which constitute the last of three types of effluent disposal methods from which the designer may choose. The choice, as indicated in Sheet 1, is largely governed by soil conditions as this type of system is the only effluent disposal method adaptable to soils rated as impervious; the other two methods being less expensive would normally be chosen for other soil conditions.

## APPLICATION

The sole advantage of sand filters lies in their adaptability to impervious soils. The limitations and disadvantages of this effluent disposal method are: Collection drains must be used and the collected effluent carried to a non-potable watercourse, or to leaching cesspools or sub-soil disposal beds in more absorptive soils. The cost is relatively high as the entire area of the filter bed must be excavated and refilled with suitable filtering material, usually clean, coarse sand. The total area, however, is considerably less than the area of land required for sub-soil disposal beds.

There are two types of sand filter. The closed type carries both the distribution and the collection drains underground in the filter bed, covering the upper layer of drains with earth. These closed sand filters may be laid out in approximately rectangular or round patterns as indicated in the accompanying drawings; or, when circumstances of site and capacity both permit, in the form of a long filter bed, having a single pair of distribution and collection drains.

The open type is far less desirable as it exposes the effluent sewage and requires a filter bed free of any covering over the sand. In some instances it is less expensive to construct and may be adapted to institutions or large estates where the filter bed is removed from the building. The effluent sewage is conveyed in

closed joint drainage lines above the surface of the bed, with outlets discharging into wood troughs which serve as splash boards, and are laid out in the same manner as the lateral branches of the drain tile system.

## DESIGN

Capacity of sand filter is expressed in its surface area in square feet and, of course, is related to the Equivalent Occupancy of the building it serves. Since this system is normally used only in impervious soils it is advisable also to determine the Relative Absorption of the soil on the site. Methods of determining these two factors are given in Sheet 1 but are repeated here for convenience.

**Rule 1.** To find the equivalent occupancy in any project, multiply the number of persons occupying the type of building by the conversion factor given in Table 1.

**Rule 2.** To determine the Relative Absorption proceed as follows: At the site of the proposed bed excavate a rectangular pit 12 inches square and 18 inches deep below the finished surface grade of that area, shaping the sides for accurate measurements as carefully as possible. Into this pit quickly pour water to the depth of 6 inches (requiring approximately 3 $\frac{3}{4}$  gallons) and measure the time required for the water to be completely absorbed by the soil. Take  $\frac{1}{3}$  of this time as the average time required for the soil to absorb 1 inch. Refer to Table 2 and find the Relative Absorption as rapid, medium, slow or semi-impervious. If the time for a 1 inch drop exceeds 60 minutes, sand filters should be used.

**Rule 3.** To find the surface area of sand filter bed required for a given Equivalent Occupancy refer to Table 3 and find in the first column the Equivalent Occupancy nearest that computed for the project. Read to the right for the area in square feet of earth for closed or open types of sand filters.

The detailed design for sand filters is clearly indicated in the accompanying drawings.

**SEWAGE DISPOSAL — 6. Sand Filters** Serial No. 22 **NOVEMBER 1935**

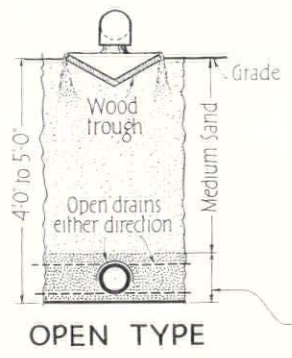
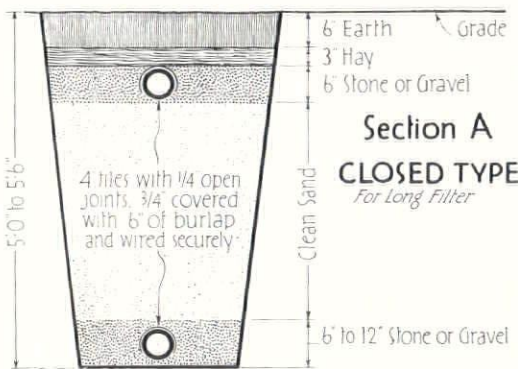
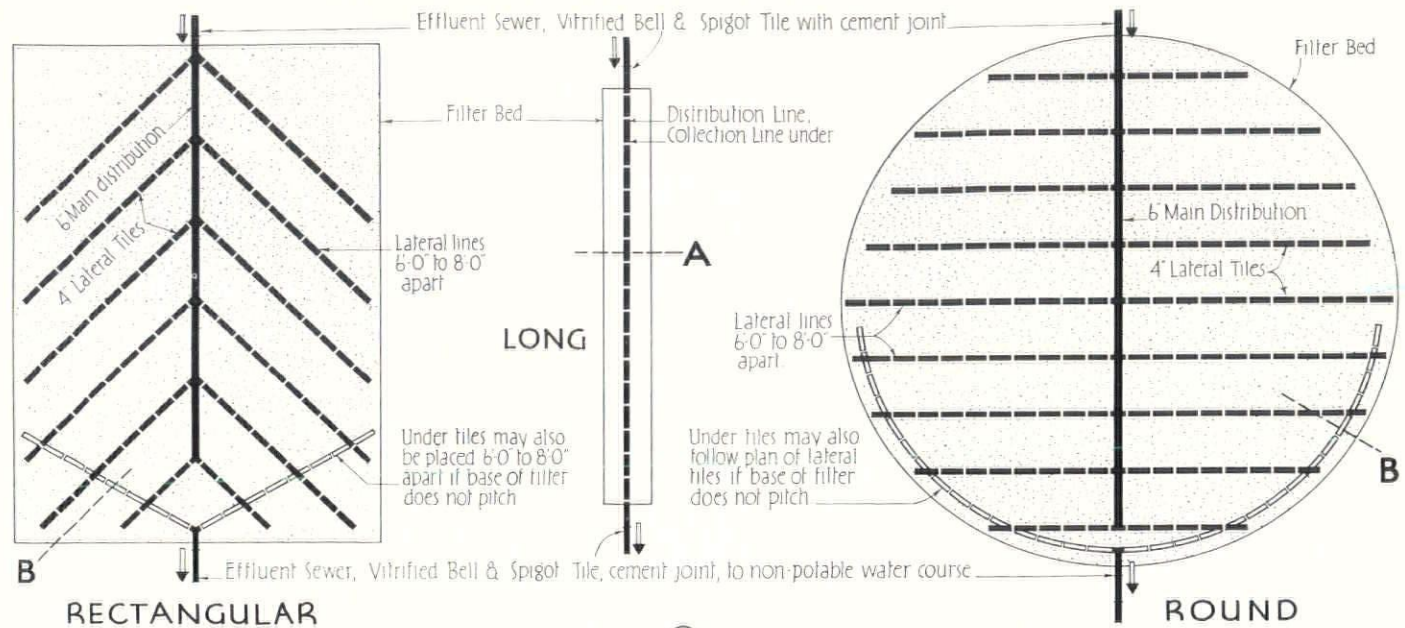

*Pitch for closed joint drains 1" to 16'-0"*  
*Pitch for open joint drains 1" to 32'-0" min 1" to 24'-0" max*  
*Bottom of Filter Beds to pitch 1" to 8'-0"*

Type of Building	Gallons per Person	Conversion Factor
Residence	50	1
Camp	25	1/2
Summer Cottages	40	4/5
Day Schools without showers or kitchens	15	3/10
Factories without showers or kitchens	15	3/10
Day Schools with showers and kitchens	30	3/5
Institutions except Hospitals	100	2
Hospitals	200	4

Time—1" drop in minutes	Relative Absorption
0- 3	Rapid Do not use Sand Filter
3- 5	Medium Do not use Sand Filter
5-30	Slow Do not use Sand Filter
30-60	Semi-impervious Do not use Sand Filter
60-up	Impervious Use Sand Filter

Equivalent Occupancy	AREA IN SQUARE FEET	
	Closed Type	Open Type
1- 4	200	100
5- 9	900	450
10-14	1400	700
15-20	2000	1000
21-25	2500	1250
26-30	3000	1500
31-35	3500	1750
36-40	4000	2000
41-45	4500	2250
46-50	5000	2500

ARCHITECTS  
ENGINEERS  
DESIGNERS  
SPECIFICATION WRITERS

in active practice may have copies of all  
Time-Saver Standards reprinted in sheet  
form for convenient desk use...without cost!

SIMPLY FILL OUT AND MAIL  
THE COUPON ON PAGE 96

# THE BUILDING WORLD

News from research laboratories, the field of practical construction, the world of manufacturing and the realm of building finance.

**A**BORTIVE attempts at prefabricated building have not been the sole result of the research fever which has gripped the construction industry—and particularly manufacturers of building materials—since 1930. Recently made public by the Reynolds Corporation of New York, is a system of house construction and equipment, the technical details of which may prove to be quite as important as the plan of co-ordinated engineering which is their basis.

Briefly, the system constitutes a method of co-ordinating the important structural and equipment factors of a dwelling with a series of prefabricated units, all of which are manufactured by the Reynolds Corporation. The resulting dwelling is not prefabricated in the usual sense of the term. A designer is allowed the fullest play as far as plan, elevation and finishing materials are concerned. But from his shoulders a staff of Reynolds engineers takes all the work necessary to develop framing plans, and complete

layouts for the plumbing, heating and air conditioning systems. Up to a certain point, both architect and builder work as they have been accustomed to do. Beyond that point, the Reynolds Corporation acts as specification writer and co-ordinating engineer.

This engineering co-ordination is limited to those structural and mechanical parts of the dwelling which are manufactured by the Corporation. These are: 1 framing and structural flooring; 2, plaster base; 3, metal insulation; 4, an air conditioning system; 5, a plumbing system; 6, steel windows; and 7, roofing. Under the Reynolds system these items are not sold as individual materials, but as part of a complete specification developed by the Corporation's engineers and co-ordinated with the architect's design and general specification.

## The Structural System

**T**HE basic framing members include joists, plates, studs and floor slabs. All are flame-proof,

terrine-proof and relatively light in weight. With the exception of the floor slabs, they are of metal, but are of such a nature that each member can be nailed, handled and used as comparable members are used in a house framed with wood. Floor joists and studs are manufactured on a stock production basis—that is, they are fabricated in sizes to meet any dimension requirement. Floor slabs, however, are produced in standard sizes.

A house constructed under the Reynolds System can be called "prefabricated" to the extent that structural members—and a large part of its mechanical equipment—arrive at the job cut to size and ready to erect in the manner traditional to the wood-framed house. Characteristics of individual members, however, make possible a greater structural flexibility and—depending upon the plan and design of the house—should produce material and labor economies in many instances.

Shapes of various members are indicated by the accompanying details. Generally speaking, all are formed of sheet metal, crimped and filled with a hard, dense material similar in appearance to a finely grained, lightweight concrete. The exception to this generality occurs in the joists and

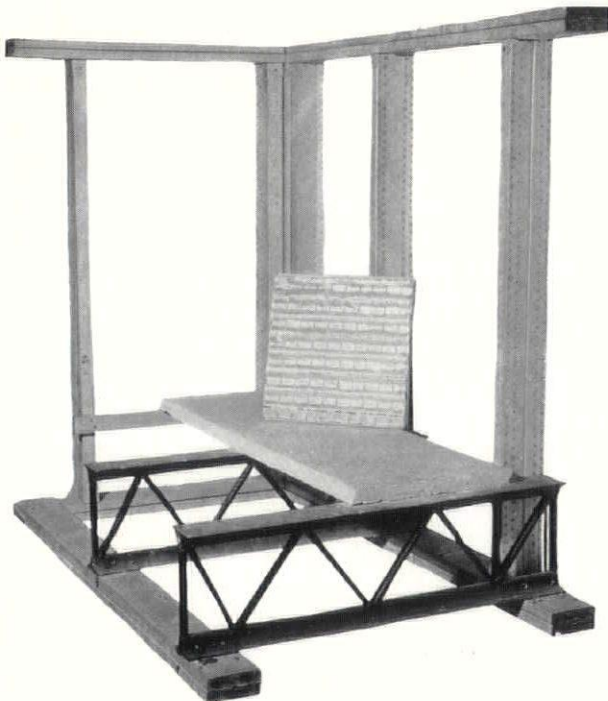

Structural units of the Reynolds System include plates, joists, floor slabs, and studs shown above and in several drawings, on page 92. Left: Detail of a typical assembly. Underside of floor slabs is a welded wire plaster base combined with metalized building paper

floor slabs. Joists are patterned after the steel open truss type. Top and bottom chords are formed of cover plates and wide flanges, crimped and filled. Between them is a series of web members spot welded to chord flanges. Chords are nailing members. Joists can be handled as in timber construction. Safe spans extend to 18 feet.

Floor slabs are made of a light-weight, pre-cast compound, similar in appearance to gypsum. The standard size is 4 feet by 15½ inches by 1¼ inches. Each slab is reinforced with a series of small bars and is cast on a metallized Ecod Fabric, a plaster base of welded wire lath and building paper.

### Construction Practice

SINCE all structural members can be handled in much the same manner as wood building units, construction progresses under the Reynolds System in much the same way as it does with conventional types of construction. After the foundation is laid, sill plates are anchored and studs toenailed at spacings of 16 or 24 inches on centers. Joists are

nailed to sills at intervals of 2 feet and are bridged every 8 feet with a 2 inch steel band. Floor slabs are laid at right angles to the span and nailed to joists. Openings are framed with bucks in place of studs. These have one concave side and one straight side.

After the first floor framing is completed, the second floor and roof is framed similarly, the whole operation being closely patterned after the technique commonly employed in wood construction. Partition studs, secured by a shoe on the floor and a plate of similar dimensions on top, are spaced 15 or 24 inches on center. They are installed after the main chassis of the house has been erected and are adapted to include necessary units of the electrical, plumbing and air conditioning systems.

After framing and mechanical installations are completed, the interior is faced with Ecod plaster base with the metallized surface facing the air space between studs. The type of exterior inclosure depends upon the desire of the architect and owner. In case of brick veneer, Ecod lath is applied directly to the studs, covered

with a parge coat of mortar and the brick laid one inch from the wall and slushed in solidly with mortar. For stucco as well as for brick veneer no sheathing is used. If the exterior is to be finished with wood siding or shingles, sheathing is nailed directly to the studs and the finish applied in the usual manner.

### Mechanical Installations

INSTALLATION of electric units does not differ materially from the procedure followed in the average house. Nor does the installation of plumbing lines and fixtures. The latter, however, are all of Reynolds manufacture and form part of the specification developed by Reynolds engineers before construction begins.

Of all the mechanical equipment of a Reynolds System house the air conditioning system is most noteworthy. It differs from other systems in two essential instances. First, it is furnished as a complete unit from burner to grilles, including ducts, supply and return lines as well as the air conditioning unit itself. This last is equipped to clean, heat, circulate and humidify, or, in conjunction with

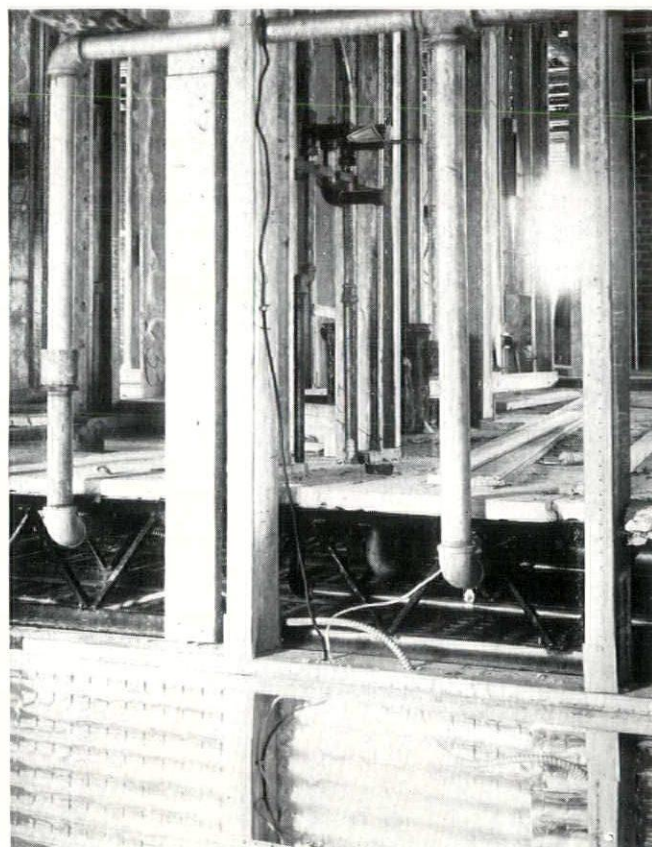
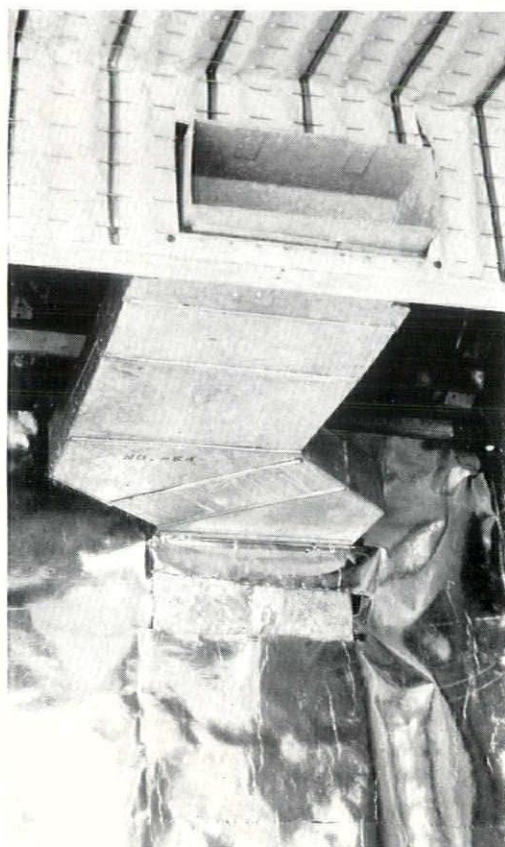

Mechanical equipment in a Reynolds System house is installed in the same manner as in traditional construction. Left: two views of the standard air conduits employed in all Reynolds air conditioning systems. Straight runs, turns and reduction units are kept in stock and assembled on the job with a snap lock joint requiring no solder or screws

# Sealex Linoleum

*meets requirements of architect and client*



NEW CATALOG—If you haven't yet done so, write for a copy of our newest "Resilient Floors" catalog. Fully illustrated, it gives thorough information about floors of the linoleum or cork composition type.



**T**HE Newark Athletic Club installation of Sealex Linoleum Floors is an example of all-round satisfaction for architect and client.

The *architect* found Sealex Linoleum adaptable to the individual requirements of each interior —

For the billiard room he selected Sealex Veltone Linoleum, installed with strips of Cork Carpet around the table areas as shown above. The Cork Carpet not only prevents slipping; its resilience quiets footsteps and lessens the impact when the ends of billiard cues come in contact with the floor.

And his requirements for colorful individuality in the combination banquet hall and ballroom (upper left) were entirely satisfied, at no sacrifice of practical advantages, by Sealex Veltone Linoleum with a decorative hand-cut inset.

And complete satisfaction is assured the *client*. For these floors, installed by authorized contractors of Bonded Floors, are backed by Guaranty Bonds covering the full value of workmanship and material. Write for information about Sealex Floors for new or remodeled interiors.

CONGOLEUM-NAIRN INC., KEARNY, NEW JERSEY

**SEALEX** TRADEMARK REGISTERED *Linoleum Floors and Wall-Covering*

the compressor, also to cool and dehumidify the air. All of its parts except the compressor are located within a steel cabinet which ordinarily is located in the basement, but may be installed in a first floor heater room if desired.

Units are built in four sizes. Circulating fans are of the low speed type and are large enough to insure a reserve capacity at higher speeds if necessary. Both motor and fan are mounted on resilient bases to reduce vibration. The oil burner, mounted directly on the combustion chamber, is of the pressure atomizing type. A cast-iron heat exchanger of the extended surface fin type is built in sections to permit a variety of sizes for different types of houses.

THE second noteworthy feature of the system is the duct arrangement. Unlike most air conditioning ducts, those of the Reynolds System are shop fabricated in a number of units and sizes that are adaptable to any distribution layout for any sized house. Size of wall stacks has been standardized to facilitate installation in regular stud

construction; and wall grilles have been designed to co-ordinate properly with these standard sized ducts. Duct units, which are kept in stock at the Reynolds factory, are assembled on the job with a snap lock which makes a strong, air-tight joint and eliminates the need for solder. Main ducts are uniformly 8 inches deep.

In combination each integral part of a Reynolds System house should produce efficiencies in construction and probably some economies in job installations. It is impossible to deal with the question of comparative costs. The idea behind the Reynolds System may ultimately produce for the owner economies over the construction of a house engineered in the traditional fashion and constructed according to the present time-honored formulas. For the architect it seems possible that the procedure described herein offers an opportunity to enlarge a small house practice, eliminate some of the elements that now constitute "production overhead" and in consequence produce a larger margin of profit from professional commissions. The extent of economies to the owner or of added profits to the

architect will remain matters for conjecture until the Reynolds idea has been thoroughly tested through practical experience. Without question, however, the idea itself points to the possibility of a more direct and logical procedure in the field of residential construction.

FOR the first time, a single manufacturer is co-ordinating a series of products used in a single building by adapting standard units to an unlimited range of conditions. It is "vertical" selling in the building field, as against "horizontal" selling of products across the entire range of building types. It portends further simplification of building design and construction in the direction of having fewer sources of materials to deal with, while the supplier rather than the buyer undertakes to relate the elements to each other. If successful, the architect's work of co-ordination ultimately may be between a few groups of vertical production agencies instead of, as now, between forty-odd trades and several hundred producers. This is a significant trend worthy of careful study and encouragement.

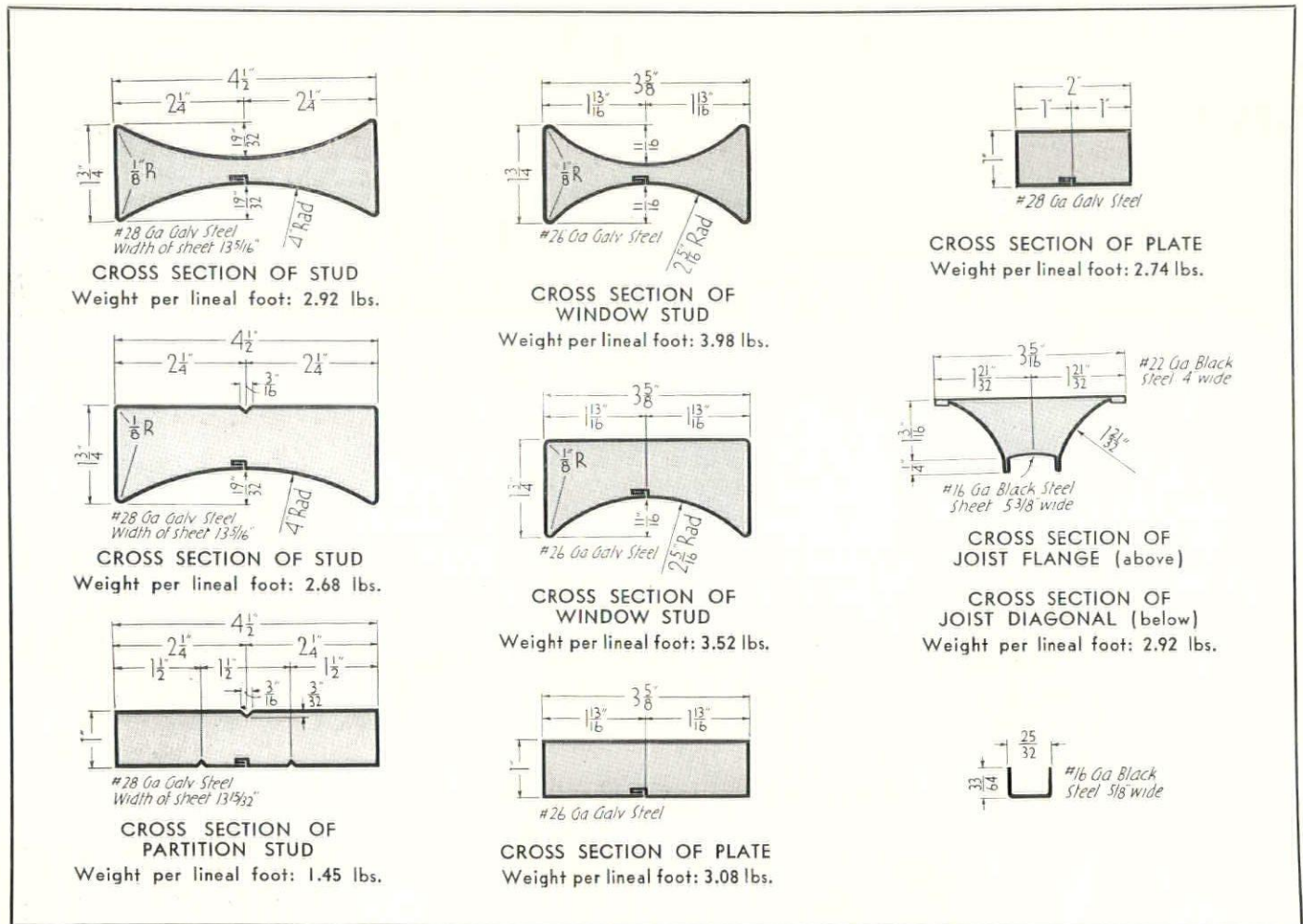



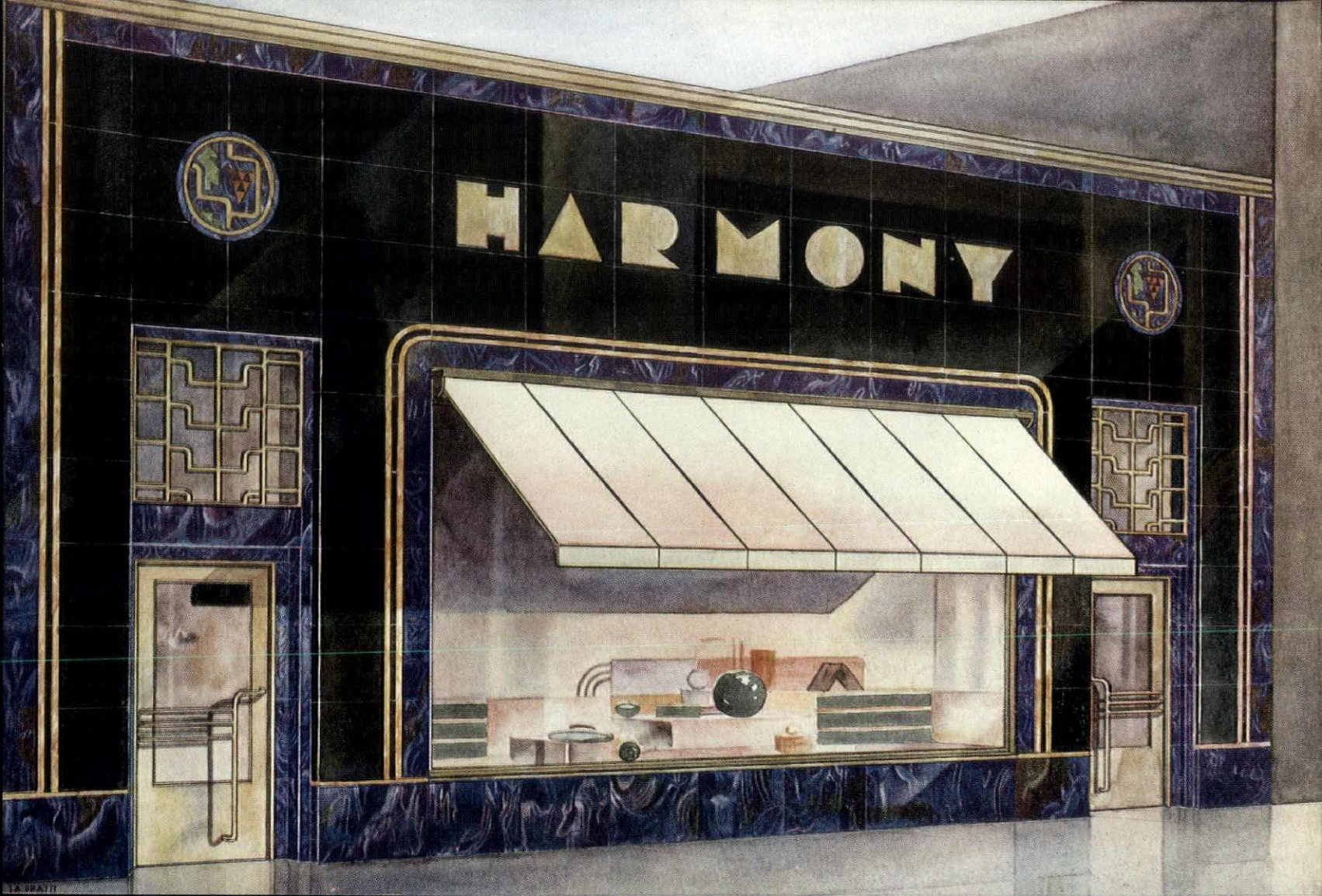

# Beautify and Modernize for Permanence with **VITROLITE**

LIFETIME beauty, today and always—modern, brilliant, colorful—that's what Vitrolite brings to new or remodeled structures.

Sixteen beautiful colors—ten rich, solid hues, six handsome agate shades, an endless variety of sandblast, inlay-decorated, and color-decorated effects—give unlimited opportunity for development of color schemes.

The gleaming, flint-like surface of Vitrolite is ever new—impervious to water, acids, oil or grease. It will not stain. It will not check, craze, or grow dull with age. It is always bright, cheerful, clean, and sanitary. A damp

cloth is the only facial treatment Vitrolite ever requires.

Vitrolite pays its own way by immediately increasing property value, by increasing ready salability or rentability of property, by attracting and increasing flow of traffic in retail establishments, by its no-upkeep cost, and by its ease and economy of installation. (Applied directly over present walls, without fuss, muss, or cost of tearing out plaster.)

Your Vitrolite Distributor has a special display easel on which he will gladly set up actual arrangements in Vitrolite to illustrate designs and color possibilities.

Vitrolite Division

**LIBBEY • OWENS • FORD GLASS COMPANY**

**VITROLITE**

A LIBBEY • OWENS • FORD PRODUCT

## The *Colorful* Structural Glass

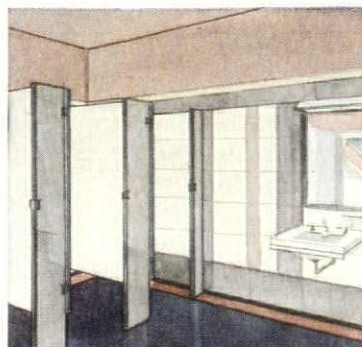

*Tear out and mail*

Vitrolite Division, Libbey-Owens-Ford Glass Co. (G-11)  
208 W. Washington St., Chicago

Please send New Vitrolite Color Chart of 16 colors—10 solid hues, 6 agate shades, and various surface effects—together with:

- Vitrolite Construction Details (Interior)
- Vitrolite Store Fronts (Colored Views)
- Vitrolite Store Fronts and Building Exteriors (Construction Details)
- Vitrolite Bathrooms and Kitchens

Name \_\_\_\_\_

Address \_\_\_\_\_

City \_\_\_\_\_ State \_\_\_\_\_



# REWIRE AMERICA

The electrical and structural modernization of America's business property is under way. Through the Federal Housing Administration, the money is available. Business men and the Government are stressing Modernization for one purpose: To create better busi-

ness for all. Architects are being asked to draft the plans.

Electrical adequacy is necessary to profitable business. You will find that the General Electric Line of Wiring Materials meets all requirements. Specify: General Electric "Safe-

cote" Code Wire, G-E White Rigid Conduit and Fittings, Switches, Convenience Outlets. Send for complete information today. Write Section CDW-2410, Merchandise Department, General Electric Company, Bridgeport, Connecticut.

**GENERAL**  **ELECTRIC WIRING MATERIALS**

## ENGLISH PUBLIC TASTE

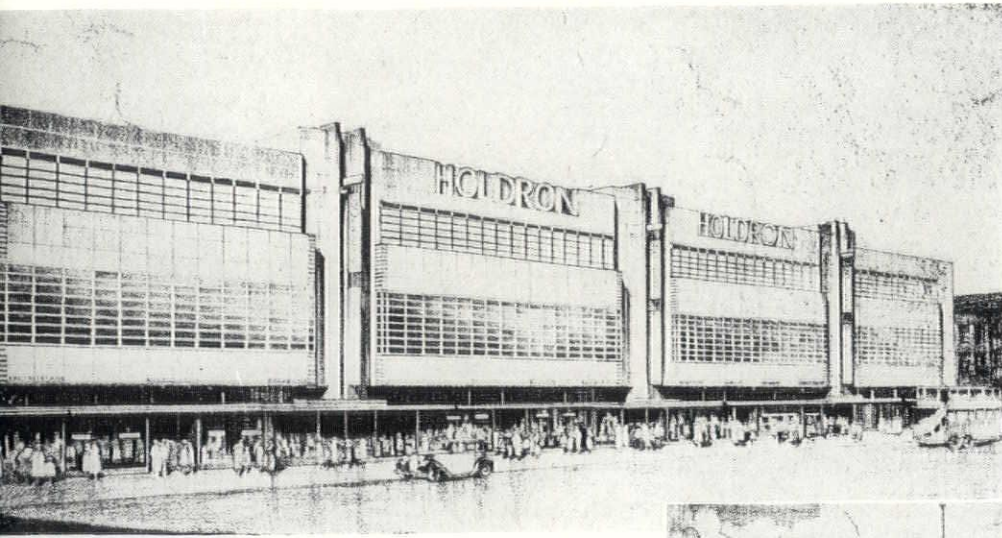

The London public voted their preference of these department store designs. Result: No. 1. 5280 votes; No. 2. 5164 votes; No. 3. 664 votes

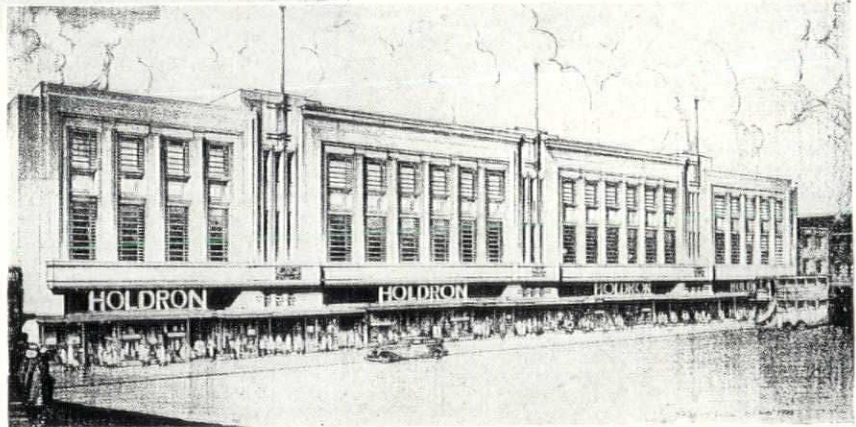

No. 2

## TRENDS AND TOPICS . . .

(Continued from page 62)

- Insured mortgage conferences or "clinics" as they are designated by Federal Housing Administrator Stewart McDonald, being held throughout the principal cities of the country are bringing about a broader knowledge of the insured mortgage system, at the same time bringing together property owners and financial institutions which are able to extend credit for dwelling construction, mortgage refinancing and property modernization on a business-like basis. Following the clinic sessions in Toledo in August, the banking interest there reported a prospective business approximating \$2,500,000, of which \$700,000 represented applications for insured mortgages to finance new dwellings.

- One of the world's largest permanent exhibition and entertainment centers is to be constructed in London, England, at an estimated cost of \$6,000,000. The building will be a concrete structure, 80 feet high, providing more than twelve acres of exhibition space on two floors. An interesting feature of the plan is a provision for a clear space of two and one-half acres on the ground floor, unbroken by columns. The building will provide seating accommodations for 25,000 and will house such shows as the British Industries Fair, the Ideal Home Exhibition and the Motor Show.

- Cautions to be taken against fire hazards in designing and installing air conditioning systems, according to E. W. Fowler, writing in *Heating and Ventilating*, are: keep ductwork localized without passing it through fire walls; heating elements should be installed with due regard to proper clearances between hot surfaces, woodwork and other combustible materials; coils carrying refrigerants, flammable or poisonous, should not be in conditioning unit or anywhere in duct system; air filters of readily flammable materials should not be used; viscous oil in air filters should have a flashpoint, not less than 300 degrees F. and ducts should be designed so as not to reduce the effective fire retarding value of walls, floors and partitions. Forced drafts of mechanical ventilating hasten spread of fire and ducts offer greater danger by spreading smoke and hot gases from room to room and to far parts of building. In selecting and installing air conditioning systems due regard should be given these suggestions.

- Through extensive research of records two centuries old or more, the exact colors used on walls of Colonial days have been discovered. Detailed descriptions and formulas for mixing pigments to reproduce these colors are now possible. Much has been contributed to authentic knowledge of early paints by the recent restoration of eighteenth-century Williamsburg, Virginia.

how to obtain *Free*

AMERICAN ARCHITECT

# Time-Saver Standards Service

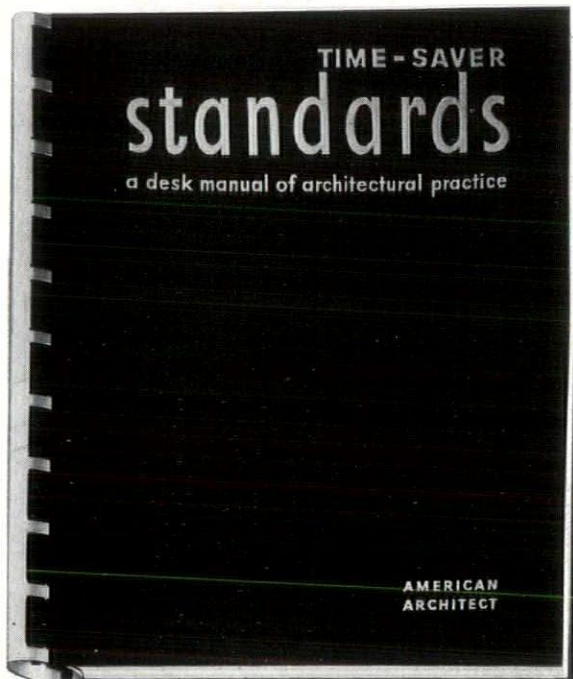

This special Tubak Binder is made exclusively for AMERICAN ARCHITECT Time-Saver Standards. The back is of one piece aluminum with the new non-farnishing Lumilite finish. Covers are semi-flexible, of a black plastic material, non-inflammable, waterproof, durable. Sheets can be removed and added instantly without damage. Price of the binder is \$1.00, postpaid, including title pages, index data and blank sheets for your own office standards.

## STOP WASTING TIME AND ENERGY

hunting for the same data on every job—stair details, window openings, sizes of plumbing fixtures and hundreds of similar things you can't carry in your head.

Simplify your daily office work by filing today an application for the new, *free* Time-Saver Standards Service offered to all eligible architects, designers and engineers. Use the coupon below.

Time-Saver Standards sheets in sets of sixteen or more are mailed periodically as fast as they can be prepared.

Each sheet is printed on both sides of durable paper stock, die-cut to fit the special Tubak Binder illustrated. You will want to keep the sheets in the binder as a handy manual for use at your own desk or drafting table. Unfortunately, we cannot supply binders free. They are available at the nominal cost of \$1.00 each, postpaid, including blank pages for your own office memoranda.

### APPLICATION FOR AMERICAN ARCHITECT TIME-SAVER STANDARDS SERVICE

Director, Technical Service, AMERICAN ARCHITECT, 572 Madison Ave., N. Y.:

Please enroll me to receive *without charge* AMERICAN ARCHITECT Time-Saver Standards sheets, as issued.

Name of Individual.....

Name of Firm.....

Address of Firm.....

Dominant class of work done by firm (principal types of buildings such as small or large residences, commercial buildings, schools, etc.).....

Position of applicant (firm member, designer, engineer, specification writer, squad boss, etc.).....

Are you a subscriber to AMERICAN ARCHITECT?..... If not, do you see it regularly?.....

I certify the above answers are correct

Signed.....

Order for Tubak Binder for Desk Manual of AMERICAN ARCHITECT Time-Saver Standards

Enclosed is \$1.00 for Desk Manual binder, index and memo sheets, postpaid

Send Desk Manual binder C.O.D. to address above. I will pay postman \$1.00 plus collection charge

Signed.....

First mailing of Time-Saver Standard sheets and binder will be made about December 15th

YOU ARE ELIGIBLE to receive without cost all Time-Saver Standards issued by AMERICAN ARCHITECT for one year if your application shows you to be:

1. A member of an architectural firm or an individual architect in private practice.
2. A consulting or designing engineer (mechanical, electrical, structural, etc.) actively engaged in building work.
3. A regular employe of an architectural or engineering organization in the capacity of executive, designer, specification writer or "squad boss."
4. A designer, supervising architect or engineer for a financial or educational institution, large property owner or developer.

USE THE COUPON TODAY!  
YOUR ANSWERS WILL  
BE HELD CONFIDENTIAL

# For the New Home and the home made new

Score another point of improvement in bathroom equipment—the new Crane ECONOMY Shower Head. The world is asking for the new, the useful, the economical in home equipment. The ECONOMY Shower Head answers that requirement with a new kind of shower, a spray using less water, and a spray at less cost.

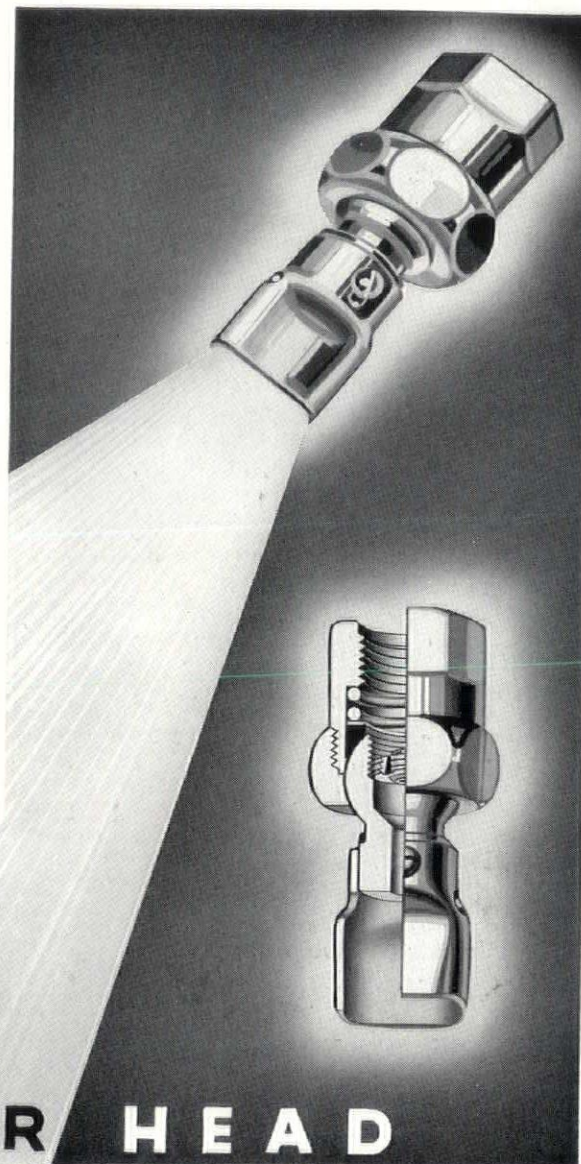

THE CRANE

*Economy*

SHOWER HEAD

MORE  
SHOWER

•  
LESS  
WATER

LOW-COST

The new ECONOMY Shower Head saves water because it directs water *only* at the bather—none is wasted as in a circular spray which is effective only at its center. Actually, only one-third the amount of water used by a 4-inch spray head is required by the ECONOMY. Large diameter outlet resists clogging. Removable brass spreader breaks up the stream by a swirling

action which precipitates good *wet* drops in place of mist-like spray. Spray guide conforms spread of shower to an elliptical shape which fits a tub, concentrates on the bather. Ball joint easily adjusted, will not corrode, has spring-loaded packing. Openings in spray guide aerate the spray, give soothing effect to body. Furnished for  $\frac{3}{8}$ " or  $\frac{1}{2}$ " pipe, with ball joint only. Of solid brass, heavily chromium plated. Cost is surprisingly low. Write for Circular No. 162.

CRANE CO., GENERAL OFFICES: 836 S. MICHIGAN AVE., CHICAGO, ILLINOIS • NEW YORK: 23 W. 44TH ST.  
Branches and Sales Offices in One Hundred and Sixty Cities

**CRANE PLUMBING AND  
HEATING MATERIALS**

## PERSONALS

• If you change your address, please report the change direct to *American Architect* five weeks before the change is to take effect, sending both old and new addresses. The Post Office will not forward copies to your new address unless extra postage is provided by you. Our request is made to save you this expense and to assure the receipt of your *American Architect*

• A warning is issued by Royal Barry Wills, Architect of Boston, that all architects and others in the building industry should be on the lookout for a young man impersonating him (Royal Barry Wills). This man is in possession of a bronze medal awarded Mr. Wills in the 1934 Better Homes in America competition which was taken from his office. The impostor will try to cash worthless checks and otherwise try to obtain money. He married a woman in New York under the name of Royal Barry Wills and presents the marriage certificate as further means of identification. The man's real name apparently is Kingsbury, according to Mr. Wills. He is described as being a man about 30 years old, 6 feet tall, weight 140 pounds, dark hair, sallow complexion, wears a brown felt hat and dark suit. Anyone who might come in contact with this man should hold him for the authorities and notify Mr. Wills in Boston immediately.

• George N. Lykos of Wilmington, Delaware, has been awarded the Medary scholarship of the American Institute of Architects for 1935-36. Mr. Lykos was graduated from the Massachusetts Institute of Technology in June, and will continue postgraduate work at that Institution. He was chosen from a group of twenty young men, representing several different colleges, who in their graduating year received A.I.A. medals for general scholastic excellence.

• Robert T. Brooks, New York, has been elected Executive Vice President of the American Institute of Steel Construction. He has been Treasurer of the Institute for the past four years and identified with the structural steel industry in New York for thirty years.

• Clifford H. James, Architect, formerly of the office of James & Zorns, Architects which was dissolved in 1932, has moved his office from 2422 15th Street, Lubbock, Texas, to 1710 Guadalupe Street, Austin, Texas.

• Henry Titus Aspinwall, Architect, announces the association with him of Paul F. Simpson in the firm of Aspinwall & Simpson, Architects. The firm is located at South Station Plaza, Great Neck, Long Island.

• Harold L. Curtiss, landscape architect, announces the removal of his office from 208 Engineering Building, University of Wyoming, to the U. S. Forest Service, Ogden, Utah.

• Edward A. Nitsche and Wilfred W. Beach, Archi-

itects, have closed their offices at 28 E. Huron Street, Chicago. Mr. Nitsche's present address is 2843 N. Kilbourne Street, Chicago, where he will continue his architectural practice. Mr. Beach, is temporarily located at 3707 W. Cambridge Street, Seattle, Washington, and will be interested in a connection with any architectural or engineering office in this country or abroad as a specification writer. He is now completing the script for his forthcoming text-book on "The Preparation of Construction Specifications," companion to his "Supervision of Construction Operations" which appeared serially in the *Architectural Forum* during 1929-32.

• The Board of Directors of the American Institute of Steel Construction has elected Mr. V. Gilmore Iden to the office of secretary. Mr. Iden has been serving the Institute, for the past year, in the capacity of Acting Secretary. He joined the Institute staff in 1927 to become its director of public relations. Prior to that time he had been engaged in newspaper work in Washington and New York.

• A. Fraser Rose & William Allan Rose, Architectural Engineers, formerly of Miami Beach, Florida, announce the opening of a structural engineering office on the top floor of the Wills Building, 286 Fifth Avenue, New York.

• Elias Nadelman, Designer, would like to have manufacturers' data on residential construction, decoration, furnishings and mechanical equipment; stores, garages, and electric lighting. He is located at 4114 4th Street, N. W., Washington, D. C.

• John Hutchins Cady, architect and planning consultant, has moved his office to Hospital Trust Building, Providence, Rhode Island. He also may be reached at the office of the State Planning Board, 520 Potters Avenue.

• Warden H. Fenton, Architect and member of the A. I. A., formerly of the office of Hiss & Weekes, announces the opening of an office for the practice of architecture at 101 Park Avenue, New York City.

• Robert Stanton, architect, has been appointed the architect for the Del Monte Properties Company and has established his office at Hotel Del Monte, Pebble Beach, California.

• S. Bossak Company, manufacturers and designers of cabinet and architectural woodwork, are now located at 408 East 25th Street, New York.

• Frederic C. Hoth & Paul B. Schumm, Landscape Architects and Engineers, announce the removal of their offices from 5 Columbus Circle to 1775 Broadway, New York.

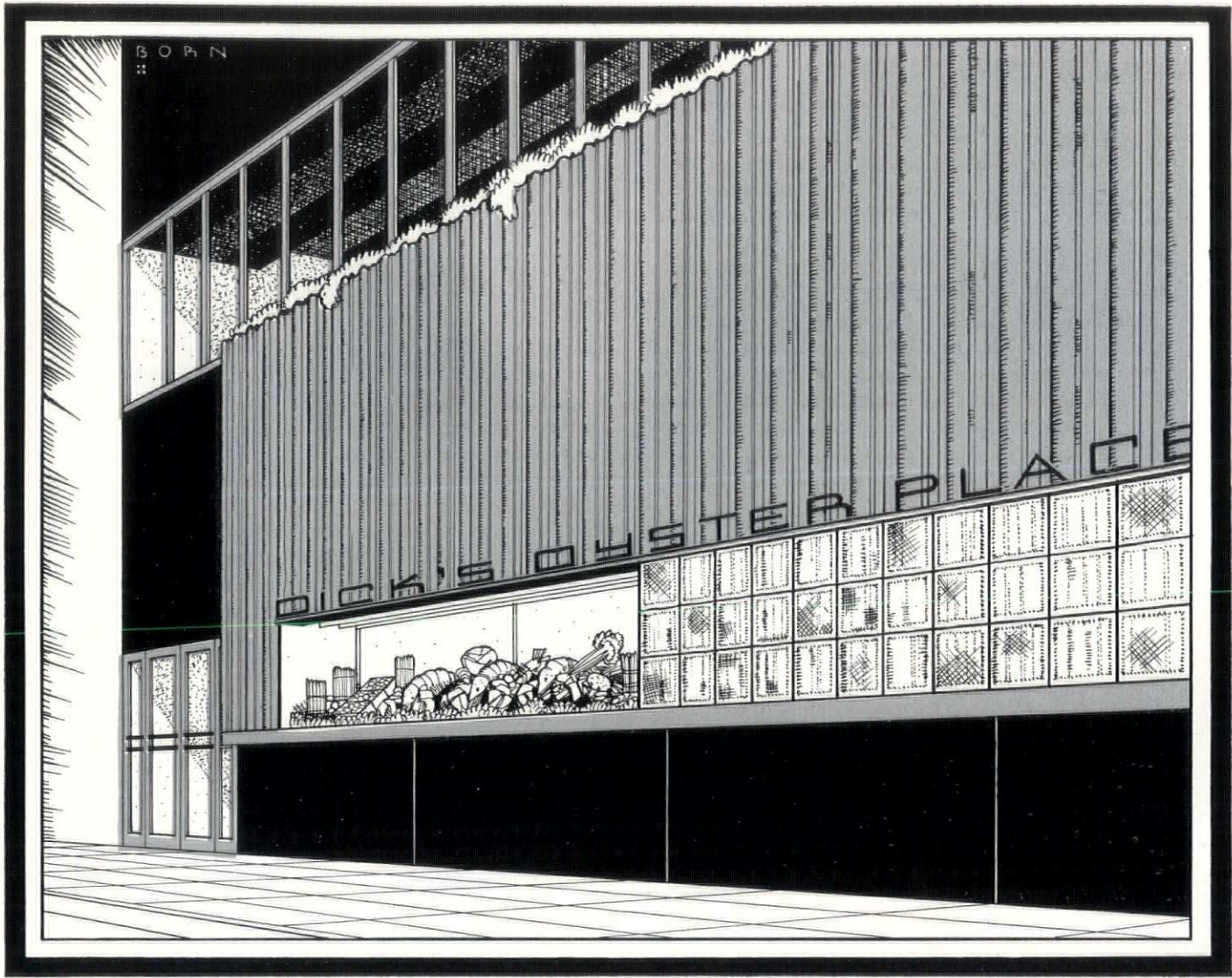

## BOTH UTILITARIAN AND DECORATIVE

The incomparable versatility of extruded Alcoa Aluminum is a fertile source of structural economy and of decorative splendor ★ Wide, extruded shapes, butted side by side, give this facade texture, brilliance, exceptional advertising value ★ Doors and windows employ extruded shapes in the usual structural manner ★ Several thousand standard shapes are available; special shapes may be produced at very reasonable cost ★ Aluminum Company of America, 1895 Gulf Building, Pittsburgh, Pa.



## ANNOUNCEMENTS

- In keeping with the current tendency to have the architectural school and the profession more intimately related, the School of Architecture, Agricultural and Mechanical College of Texas, announces the appointment of Maurice J. Sullivan, of Houston, Texas, as critic in design. Mr. Sullivan is a member of the American Institute of Architects, a past president of the South Texas Chapter, and has had a long and successful practice in Houston. His years of experience and sympathetic understanding of the student's problem will undoubtedly be of great value to the students and to that institution. Mr. Samuel B. Zisman, who has been an instructor in architecture at the Massachusetts Institute of Technology for the past five years, will have charge of the elementary work in design.
- Mrs. Frances M. Pollak, Director of the Art Service Projects of the WPA, announces the opening of a design school to be known as the Design Laboratory, and patterned after the famous Bauhaus of Germany. The school will be under the direction of Gilbert Rehde and will be held at the Y. M. H. A., Lexington Avenue at 92nd Street, New York. The school will offer instruction in industrial design, graphic arts and fine arts. There are no entrance requirements and the professional artist will be just as welcome as the amateur. Students will be placed in classes which best suit their needs, and instruction will be individual rather than mass. The school opened on November 11th.
- A study of air conditioning will be made for the first time this year in the Columbia University Extension, New York, it is announced by Director James C. Egbert. John Everetts, Jr., secretary-treasurer of Air and Refrigeration Corporation and an associate of Walter Fleisher, air conditioning engineer, will make a comparative analysis of refrigerating equipment and refrigerants used in connection with air conditioning. The new course will be given on Wednesday and Friday evenings in the department of architecture.
- The President and Fellows of Harvard University announce a gift of \$100,000 as a foundation for a fellowship in architecture, in memory of Arthur W. Wheelwright of the class of 1887. The yearly income, approximately \$3,500, is to be awarded annually for travel and study outside the United States to some student who has completed a satisfactory course in architecture; this student is to be chosen on his complete record rather than by any one test, examination, or competition. The entire \$3,500 will be paid upon departure from the United States, and the period of study is not limited to one year. The recipient shall not be required to account for the expenditure of the money nor to make any report concerning his travel and studies. The candidate will be selected by the council of architecture or whatever body controls the curriculum of architecture.
- The Fellowship and entire sum involved will go to one candidate for one year and not be divided between two or more persons. With the gift of this Fellowship, the School of Architecture at Harvard becomes richly endowed with five traveling fellowships.
- A contest for a poster to stimulate European travel, with prizes totaling \$800 and a round trip passage to Europe, is announced by the Institute of Foreign Travel, New York City. The contest will be open to artists of the United States and Canada, and three prizes, the first \$500 and a round trip passage to Europe, the second \$200 and the third \$100, will be awarded. Posters are to be in color and to scale to 23 inches by 36 inches. The art work is to be built around the phrase, "See Europe Next," and must be general enough in appeal to stimulate travel to Europe as a whole, by all steamship lines. Charles T. Coiner, Byron Musser, Gordon Aymar, Edward F. Molyneux and Edwin Georgi have been selected as a jury of award. Entries must reach the Institute of Foreign Travel, 80 Broad Street, New York, not later than December 31, 1935.
- The Metropolitan Museum of Art, New York, announces several courses of combined classroom and gallery lectures on the principles of design. The short courses for the public and for members consist of eight study hours. While each course is complete in itself and forms a unit, the units are arranged as sequences to run through the season. In the Sunday series alternate lectures will be given by outside specialists in design. Among these are: Edgar I. Williams, on Design in Domestic Architecture; Eugene Schoen, Design in Furniture; Miss Nancy McClelland, Design in Wall Coverings; John C. Milne, Design in Textiles; Walter W. Kantack, Industrial Design Today: Metals; and Leon V. Solon, on Industrial Design Today: Pottery and Glass.
- The College of Architecture of the University of Michigan at Ann Arbor, announces a number of changes in its curricula. While retaining for a short time longer the four year program, partly as a base for the five year plan announced in 1933, the latter has been developed with a view to meeting the needs of the student as an individual rather than having identical requirements for all. To this end there are offered five options or groups of courses to be added to the four year basic program, or combined with it over a period of five years. These options are in general education, architecture, business administration, historical and decorative art and in city planning and housing. They will be offered in collaboration with the other divisions of the University. For the degree of Bachelor of Design there are also options, in interior decoration and other related fields, with a four year program in drawing, painting and design.



- New York University, School of Architecture and Allied Arts, announces a series of courses designed for those who desire instruction preparatory to standing examination for architects' licenses. These courses review the fields of architectural design, construction and practice. They have been planned to meet the requirements of the various state licensing boards of architecture, and include a review of questions similar to those given during past examinations. For those who have had experience in the various phases of architectural practice they offer a review and preparation in any particular specialty in which the students are deficient. The courses are thoroughly practical and will be given by men who are specialists in their various fields of practice. Admission is open to those who are eligible for the examination for architect's license or who have equivalent professional qualifications, provided official credentials of previous schooling and experience are submitted in advance.

- The Architectural League of New York announces its Fiftieth Annual Exhibition to be held at the Grand Central Palace from February 10th to 19th. The last day for advance submission of photographs has been set for December 16th; return of entry slips on January 8th; exhibits received on February 3rd; preview for the press and invited guests will be held on February 9th; award of medals will take place on the same date and the exhibition will be open to the public on Monday, February 10th.

- Architectural clubs, Societies and other organizations interested in holding exhibitions of small house designs are invited to apply for inclusion on the schedule for the traveling show of about seventy-five drawings, including prize winners and mentions, submitted in the *Pencil Point* 1935 Architectural Competition, sponsored by the Iron Fireman Manufacturing Company.

\* \* \*

- It is encouraging to note that privately financed building construction is contributing to the upturn in the heavy industries, reports the American Iron and Steel Institute. During the second quarter of this year output of steel for building construction increased by 14 per cent over the first quarter. The increased demand for steel products in the second quarter coincided with gains of nearly 100 per cent over the first quarter in residential construction and 25 per cent in non-residential building. By contrast, public works contracts were down 10 per cent from the first quarter and 52 per cent below the average for the first half of 1934. An upturn in the heavy industries is indicative of a rising building market.

\* \* \*

- In connection with the illustration appearing on page 62 of our October issue, it has been called to our attention that the architectural contract for the United States Supreme Court Building was awarded to Cass Gilbert, Cass Gilbert, Jr., and John R. Rockhart.

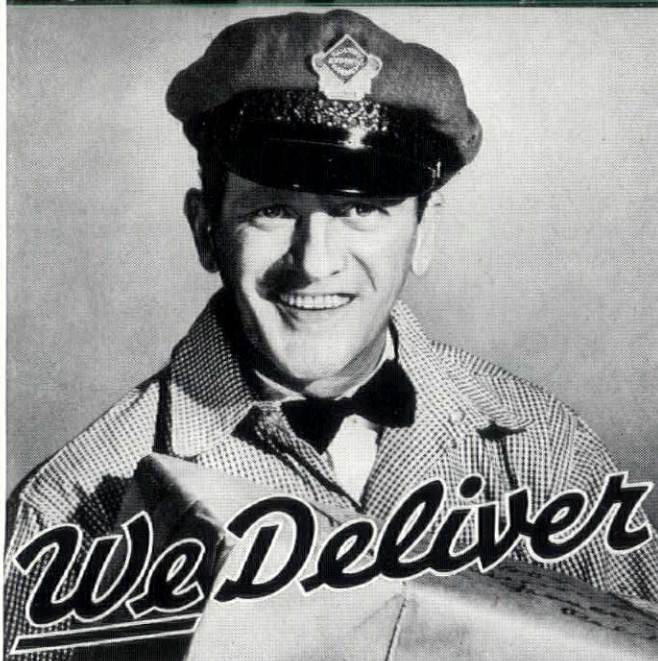
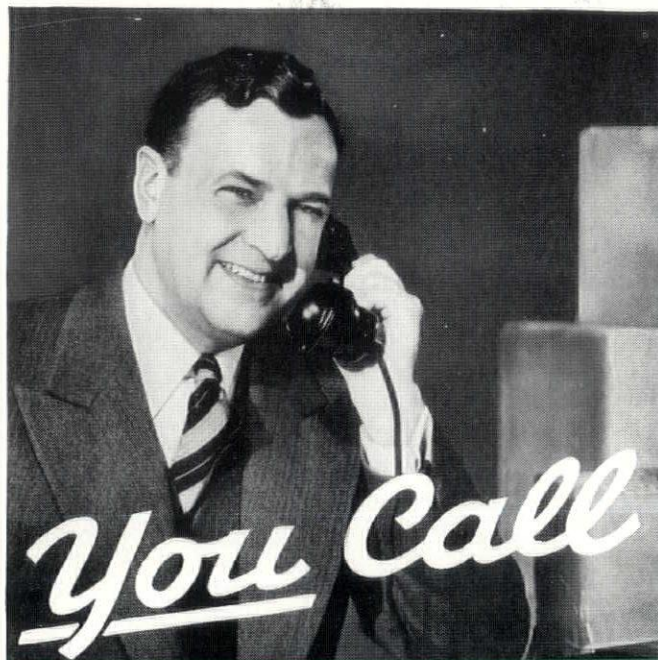

It doesn't matter what you wish to ship or order, Railway Express will rush it at passenger train speed. Prompt pick-up and delivery service in all important cities and towns. Low rates. For service or information telephone the nearest Railway Express office.

ON THE AIR

TUNE IN on the RAILWAY EXPRESS NEWS PARADE

Every week from the following stations

Boston, WEEI • New York, WOR • Cleveland, WHK  
 • Chicago, WLS • St. Louis, KWK • New Orleans,  
 WDSU • Dallas, WFAA • Atlanta, WGST • San Fran-  
 cisco, KYA • Los Angeles, KNX • Seattle, KOMO  
 Minneapolis-St. Paul, KSTP

Watch for local announcements

# RAILWAY EXPRESS

AGENCY, INC.

NATION-WIDE RAIL-AIR SERVICE

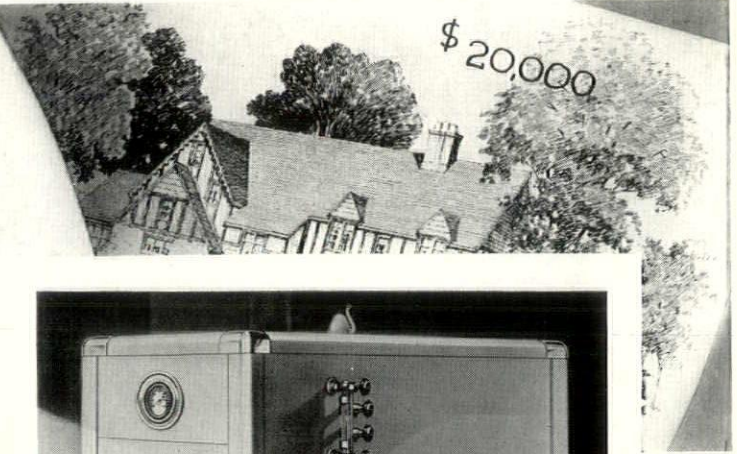
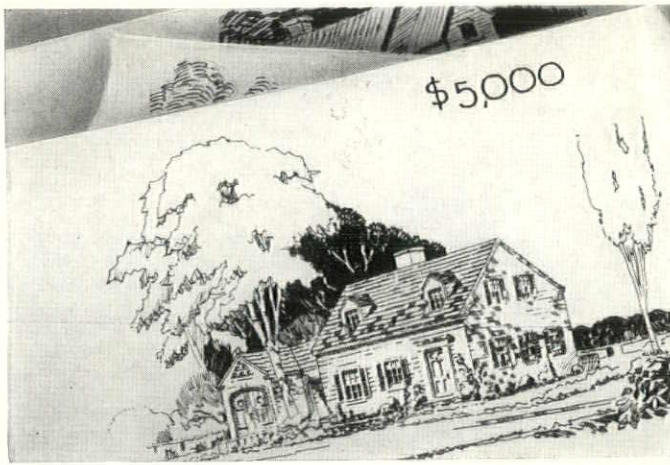

**"Seven livable homes"**

*ranging in price from  
\$5,000 to \$20,000,  
built by Boston's  
big department store,  
Jordan Marsh Company*

**all heated by**

# FITZGIBBONS OIL-EIGHTY AUTOMATIC STEEL OIL-BURNING BOILERS

There is deep significance in this selection by Jordan Marsh Company of one make of boiler for seven different sized homes, financed by seven different sized incomes. The modest home demanded economy first—the luxurious residence required brilliant performance and beauty as well as adaptability for use with a well-known air-conditioned unit. All of these considerations are equally well served by the Oil-Eighty Automatic.

In addition these homes will all get year-'round INSTANT HOT WATER without the need of a storage tank—another outstanding feature of this modern oil-burning boiler.

Built throughout of corrosion-resistant copper-steel, designed as only steel construction will permit, on the scientifically correct lines for the burning of oil, these boilers are proving in all sections of the country the true value of oil as fuel, and the true importance in the home of modern automatic heat.

Built in thirteen sizes—ample to fit any residence from the small home to the large estate. (Other types for larger installations.)

## ***Fitzgibbons Boiler Company, Inc.***

GENERAL OFFICES: 570 SEVENTH AVE., NEW YORK, N. Y.

Works: OSWEGO, N. Y.

BRANCHES AND REPRESENTATIVES IN PRINCIPAL CITIES

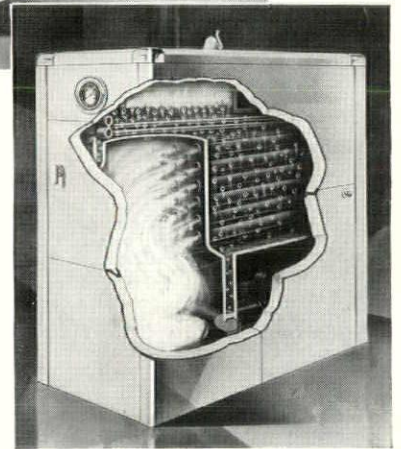
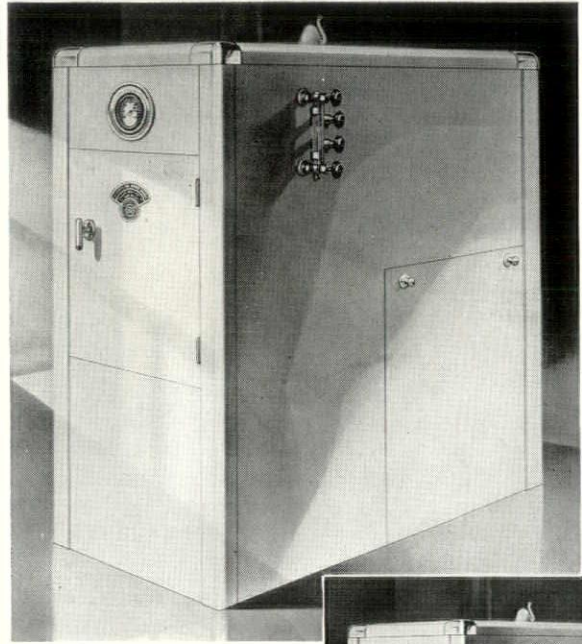

### **WORKS WITH ANY BURNER**

In thousands of installations, over two hundred and fifty different makes of oil burners are doing their best work, teaming up with the Fitzgibbons Oil-Eighty. The burner may be placed behind the panel, inside the jacket, away from damage, prying fingers, dust or dirt—and where any combustion sound is muffled.

**GET THE FACTS—NOW  
WRITE FOR OIL-EIGHTY  
CATALOG AM**



# NEW CATALOGS . . .

Readers of AMERICAN ARCHITECT may secure without cost any or all of the manufacturers' catalogs described on this and the following page by mailing the prepaid post card printed below after writing the numbers of the catalogs wanted. Distribution of catalogs to draftsmen and students is optional with the manufacturers

## KENMAR COPPER SHINGLES

796... The features and inherent qualities of Kenmar Copper Shingles for residences, small or large buildings with pitched roof areas, are described and illustrated in a colorful 8-page booklet issued by The New Haven Copper Co., Seymour, Conn. Details, including weights, colors available, approximate cost, and notes on installation methods, are given.

## CONCRETE FLOOR DESIGN

797... Portland Cement Association, Chicago, has issued a 72-page booklet on the simplified design of concrete floor systems. This booklet enumerates and discusses various concrete floor systems and their characteristics, and illustrates methods of design by typical examples. A large part of the booklet is devoted to structural design charts and concludes with a section on special details of construction.

## ELEVATORS AND DUMBWAITERS

798... A sixteen-page catalog has been issued by John W. Kiesling & Son, Inc., Brooklyn, N. Y., which gives data on their line of dumbwaiters, sidewalk elevators, invalid elevators, residence elevators and elevator cable equalizers. Descriptions of each type of unit and brief specifications are given. Filing size; A. I. A. file 33.

## GRINNELL THERMOFIN

799... Grinnell Company, Inc., Providence, R. I., has published a 12-page catalog on its Thermofin unit, a convector for room heating. Complete details are given on both types available—Simplex Thermofin for single-pipe heating systems and Duplex Thermofin for two-pipe heating systems—including mechanical features, design of cabinets, and capacities and dimensions. Filing size; A. I. A. file 30-C-4.

## HOT WATER STORAGE HEATERS

800... General information on Patterson solid Everdur Hot Water Service and Storage Heaters is contained in a four-page catalog issued by Patterson-Kelley Co., East Stroudsburg, Pa. Capacity tables, a suggested specification form, and illustrations of typical installations are included. Filing size; A. I. A. File 29-D-25.

## WEBSTER BOILER PROTECTORS

801... A discussion of boiler failure and how it can be prevented by using the Webster Boiler Protector is contained in an 8-page filing-sized catalog issued by Warren Webster & Co., Camden, N. J. It explains how this unit works, gives its capacity, and describes its design and construction.

## C-E STOKER UNIT

802... The new C-E Stoker Unit, applicable to all types and sizes of boilers from small heating units to power boilers developing up to 400 h.p., is described in a 4-page booklet issued by Combustion Engineering Co., Inc., New York. All details of the stoker unit are clearly illustrated, together with a number of typical installations in various buildings.

## TRANE ORIFICE SYSTEM

803... The Trane Company, La Crosse, Wis., has issued Bulletin 105, an 8-page filing-sized catalog which illustrates and describes the Trane Orifice System used in conjunction with convection heating, with or without humidifier. Installation details and schedule of pipe sizes are included.

## LIGHTING FIXTURES

804... A special 16-page booklet which describes and illustrates the lighting equipment designed for the General Electric "New American Homes" has been published by Lightolier Company, New York. A chart is included which shows the various types of fixtures designed for each particular house in the group.

## STANLEY MAGIC DOORS

805... Stanley Magic Door equipment for the operation of heavy entrance doors in stores, office buildings, hotels, factories, hospitals, etc. by means of a photo-electric cell arrangement, is described in a four-page catalog (Form B-77) issued by The Stanley Works, New Britain, Conn. Typical installations of this type of equipment are shown. Other types of Stanley Door Operators are also described. Filing size; A. I. A. file 27-C-3.

## J-M INDUSTRIAL PRODUCTS

806... Insulation materials, refractories, floorings, roofings and transite in its various forms are a few of the products described in a comprehensive 48-page catalog of industrial products issued by Johns-Manville, New York. The booklet is profusely illustrated with photographs, drawings, tables and charts, and contains detailed recommendations for insulating in various industries.

## KEWANEE RESIDENCE BOILER

807... The Kewanee Residence Type R Boiler, which is available in models for coal, oil or gas burning for heating bungalows, homes and smaller buildings is described and illustrated in Catalog 88g issued by Kewanee Boiler Corp., Kewanee, Ill. Detail drawings, rating and measurements, specifications and other data are included. These boilers may also be equipped with indirect hot water coils and an auxiliary incinerator. Filing size; A. I. A. File 30-C-1.

NO POSTAGE REQUIRED ON THIS CARD

AMERICAN ARCHITECT, New York

November, 1935

Please have the following catalogs reviewed in this issue sent to me.  
Numbers .....

• I also desire further information about the new products described in this month's "New Materials and Equipment." . . . (See pages immediately following this insert.)

Numbers .....  
• I would like to have catalogs and information concerning the following products advertised in this issue. (Write page number or name.)

Check here for FREE copy of "WHEN YOU BUILD" booklet.

Name .....

Firm name .....

Address .....

City .....

Occupation .....

# These NEW Catalogs may be obtained through AMERICAN ARCHITECT

## GUTH INDIRECT LIGHTING

808... Illustrations and descriptions of various types of indirect lighting equipment are contained in Catalog 28 recently issued by The Edwin F. Guth Co., St. Louis, Mo. Dimensions, wattages and list prices for each type of unit are given. Filing size; A. I. A. File 31-F-23.

## STURTEVANT UNIT VENTILATORS

809... The problem of ventilating school buildings is discussed in Catalog 377-1, a new 20-page filing-sized booklet issued by B. F. Sturtevant Co., Hyde Park, Boston, Mass. The features and characteristics of Sturtevant Unit Ventilators for school rooms are fully described. Also included are capacity tables, dimension data, specifications and details showing standard arrangements of de luxe units.

## CONCEALED AWNING ENCLOSURES

810... Newman Bros., Inc., Cincinnati, Ohio, have issued a 12-page catalog which gives complete details on Newmanco Concealed Awning Enclosures for store fronts. Detail drawings show the application of these enclosures to six typical store fronts. The booklet also contains data on glass setting moulds and other Newmanco products. Filing size; A. I. A. File 15-A.

## KINNEAR DOORS

*Three booklets have been issued by Kinnear Mfg. Co., Columbus, Ohio.*

811... A four-page folder giving data and illustrations on Kinnear Power Units for operating rolling metal doors. Filing size; A. I. A. File 16-D-13.

812... "Kinnear Steel Rolling Service Doors" is a four-page folder illustrating and describing the advantages and mechanical features of this type of door. Filing size; A. I. A. File 16-D-13.

813... An eight-page broadside pertains to Tip-Top Door Hardware for garage doors. It illustrates several typical installations and gives brief specifications.

## LEWIS AIR CONDITIONING

814... Several types of air conditioning units manufactured by Lewis Air Conditioners, Inc., Minneapolis, Minn., are presented in a new 8-page catalog. Included are data on the H-1 Series, a cabinet-type humidifier for homes, offices, shops and like areas; the H-2 Series, a similar unit for smaller homes; the M-3 Series for indirect or split system all-year air conditioning; and the GC Series for converting a gravity type furnace into a winter air conditioning unit.

## REPUBLIC WIRE PRODUCTS

815... A new 40-page catalog (Form ADV. 226-B) on Republic wire, rods, wire nails, wire staples and fence posts has been prepared by Republic Steel Corporation, Massillon, Ohio, giving complete up-to-date information on these products, with illustrations.

## WATERFILM BOILERS

816... Waterfilm Boilers, Inc., Jersey City, N. J. has issued a portfolio which contains complete data on its Waterfilm boilers for oil and automatic firing. Ratings, dimensions, prices and other pertinent data are included. Filing size; A. I. A. File 30-C-14.

## FURNACE BLOWERS AND FANS

817... The Emerson Electric Mfg. Co., St. Louis, Mo., has issued Catalog X573 which gives complete information on Emerson furnace fans, blowers, air washers, filter housings, and bonnet controls for warm air heating and air conditioning systems. Specifications, dimensions and list prices are given.

## METAL LATH AND ACCESSORIES

818... The principal types of metal lath and metal lath accessories manufactured by Penn Metal Company, Parkersburg, W. Va., are illustrated and described in a new 16-page filing-sized catalog. Data on sizes, weights, uses, etc. are also included.

## HOLOPHANE IN-BILT LIGHTING

819... To demonstrate the flexibility of In-Bilt Lighting and its adaptability to specific needs for both concealed and exposed lighting, the new 20-page booklet issued by Holophane Co., Inc., New York, shows many typical installations of this type of lighting and gives interesting details of each project. An 8-page supplement gives engineering and estimating data.

## EXCELSCO HOT WATER SUPPLY EQUIPMENT

820... Factual data on Excelso indirect water heaters, fuel oil preheaters, Tempo mixing valves, direct water heaters and Klearway cleaning valves are contained in a 14-page portfolio issued by Excelso Products Corp., Buffalo, N. Y. Construction features, capacity tables, installation data, are given for each of these products. Filing size; A. I. A. File 29-D-2.

## KOH-I-NOOR DRAWING MATERIALS

821... Koh-I-Noor Pencil Co., Inc., New York, has issued a 16-page illustrated catalog and price list on its line of drawing and sketching materials.

## DECORATIVE SILKS

822... "Silk Merchandise News," a new 12-page brochure published by International Silk Guild, New York, contains interesting discussion of various types of silk drapery, upholstery and other decorative silk fabrics. Each fabric is described, the range of colors given and, in some cases, typical uses of the material are suggested. The booklet is profusely illustrated with pictures showing selected patterns of some of the fabrics.

## ARMSTRONG'S LINOWALL

823... A beautifully prepared 24-page consumer booklet, "Colorful Walls That Never Grow Old," has been published by Armstrong Cork Company, Lancaster, Pa. which presents data on Armstrong's Linowall, a linoleum base wall covering. It gives description of the material, hints on where and how to use it, and pictures of typical interiors printed in natural color. Also included are installation instructions and full color illustrations of various patterns in which this material is available.

## CONCRETE REINFORCING BARS

824... A new bar card recently issued by the Concrete Reinforcing Steel Institute, Chicago, Ill., gives areas and weights of the eleven sizes of concrete reinforcing bars which have been adopted as standard by the industry.

FIRST CLASS  
PERMIT NO. 5  
(Sec. 510 PL & R)  
NEW YORK, N. Y.

**BUSINESS REPLY CARD**

NO POSTAGE STAMP NECESSARY IF MAILED IN THE UNITED STATES

2c. POSTAGE WILL BE PAID BY

**AMERICAN ARCHITECT**

572 Madison Avenue

New York, N. Y.

AMERICAN ARCHITECT

# New Materials and Equipment

## G-E Room Cooling Unit

**521M** A self-contained room cooling unit which operates on ordinary 110-volt A.C. lighting circuit, requiring no special power connection, has been announced as being the first of its kind. Designed for single-room use, it cools, dehumidifies and circulates the air and also provides ventilation from outdoors. The unit itself is air cooled. Moisture taken from the room air is evaporated and carried outside by a stream of air, eliminating need for water and drain piping. Use of three compressors, instead of one larger unit, permits operation on light circuit, as sequence starting of four motors (one for fans and one for each compressor) prevents overloading and heavy inrush of starting current. The new unit is manufactured by General Electric Co., Bloomfield, N. J.



## Friez Air Meter

**522M** A moderately priced instrument for use in studying and measuring pressures or vacuums as well as velocities in feet per minute of air inside of ducts or at the faces of grilles, fans, etc. has recently been placed on the market. This Friez Air Meter covers velocities as low as 140 fpm and up to 2832 fpm, and pressures or vacuums as low as .00125" and up to .50" of water. It carries dual scaling throughout in both inches of water and velocity. The zero correction and leveling devices are integral parts of the instrument. This new product of Julien P. Friez & Sons, Inc., Baltimore, Md., is intended for field use only and not for exacting research work.

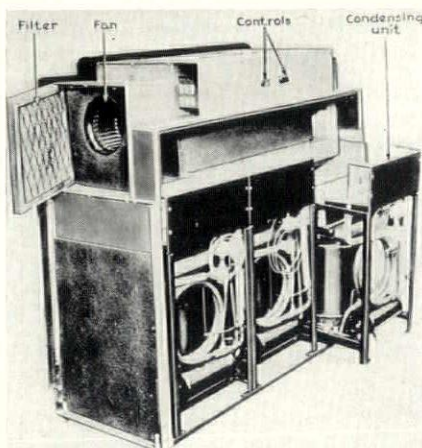

## Kelvinator Oil-Burning Boiler Units

**523M** Three new oil-burning boiler units, combining a sectional cast-iron boiler, water heater and automatic controls, have been introduced for new or existing residences and commercial buildings. They are designed for steam, vapor or hot water heating systems and provide total heat radiation of 780, 1230, and 1635 sq. ft. respectively for steam and 1170, 1845 and 2450 sq. ft. for hot water. Provision for year around air conditioning equipment is made in each unit. The entire mechanism and boiler of the units are enclosed in a

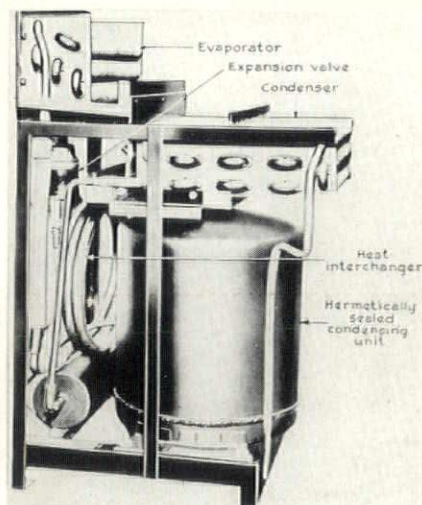

steel jacket, insulated with asbestos board and finished in gray enamel trimmed with bright chromium. These three boiler-burners complete the line of automatic heating equipment manufactured by Kelvinator Corp., Detroit, Mich.

## Stainless Steel Tubing

**524M** A thin wall stainless tube, without or with carbon steel inserts which are fabricated into the tube when applications demand additional strength and rigidity, is a new form of architectural tubing. It is known as Allegheny Metal Architectural Tubing and is available in round O.D. sizes  $\frac{5}{8}$ ",  $\frac{3}{4}$ ",  $\frac{7}{8}$ ", 1",  $1\frac{1}{4}$ ",  $1\frac{1}{2}$ ", 1.9"; also in certain sizes of square and rectangular shapes. It has been introduced by Allegheny Steel Co., Brackenridge, Pa.

## Triangular Protractor Scale

**525M** A useful time-saver scale for office, field and school work combines five calculators in one and permits laying out angles to degrees, minutes and seconds. Made in pocket size of celluloid, it also contains an ordinary scale (half full size), a decimal scale, a bevel or slope scale, and a trigonometric computer. The information obtained, it is claimed, can be applied to any 12" ruler with accurate results, and eliminates the ordinary protractor. The scale is offered by The Triangular Protractor, 654 Schenck Avenue, Brooklyn, N. Y.

## G-E Automatic Time Switches

**526M** Wide adaptability, simplicity, reliability and low-cost installation and maintenance are features claimed for two new general-purpose automatic time switches. One unit, designated as Type T-17, is for either indoor or outdoor use and is designed to control almost any electric circuit on a schedule related to the time of day. It will perform any practical number of operations per day and can be set to skip one or more days if desired. The other unit, Type T-27, is for indoor use only and is similar to Type T-17 except that it is not equipped with a weatherproof case or with an omitting device for selected days. These switches are manufactured by General Electric Company, Schenectady, New York.

## Streamlite Flat Wall Paint

**527M** A new type of interior paint, called Streamlite Flat Wall paint, uses water as the thinning medium and is said to dry in thirty minutes when applied upon the average

surface. According to the manufacturers it covers in one coat and can be applied to any surface wet or dry, is non-inflammable, leaves no brush marks or paint odor, is easily washed and may be tinted to any color. Exceptionally high light reflectivity is claimed for the paint which is a product of the A. C. Horn Co., Long Island City, N. Y.



New Briggs Plumbing Ware

**528M** A new drawn-metal lavatory, measuring 20" x 24" is supported by streamlined or wing designed wall brackets and takes standard fixtures, either group or individual. It has a removable overflow pipe for cleaning, a wide ledge all around and a bead to prevent water from dripping over the edge. A bracket adjustment permits installing it flush against the wall or two inches away. Announcement is made also of a sink and tray combination in double tray or double sink ensemble, or with right or left sink and laundry tray. The fixture is supplied either with or without back and with cabinet or legs and wall bracket. Both products are manufactured by Briggs Manufacturing Co., Detroit.

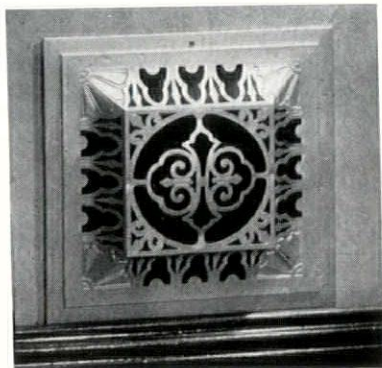

Electromode Unit Heater

**529M** A feature of the new Electromode Heater is its cast-in electric heating unit, which con-

sists of a helicoil sheath-wire type of resistance heater element cast integral with an aluminum fin-type grid. These fin-type grids, it is said, give maximum dissipation of heat in a given area, making possible compact units of high Btu output. The heat transformed from electrical energy is conducted through the fin area of the heating unit and is carried off by forced air circulation. These heating units operate with a maximum temperature of 250 F. Electric Air-Heater Co., Mishawaka, Indiana, is the manufacturer.

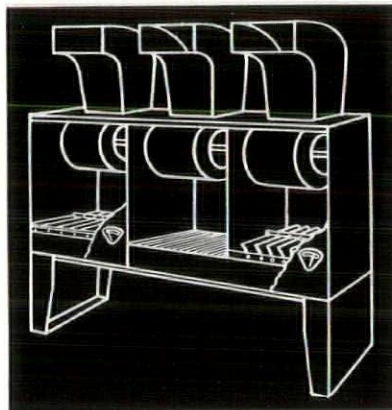
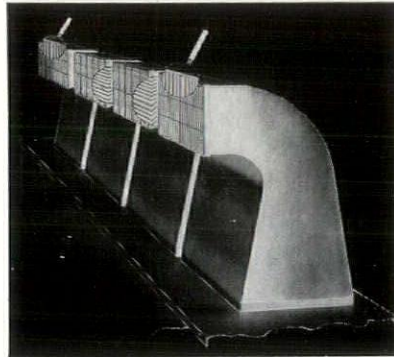

Trane Unit Heaters

**530M** Several new features have been added to the 1936 line of propeller and blower type unit heaters produced by The Trane Company, La Crosse, Wis. The propeller type units have improved appearance, all corners rounded, a crinkle brown furniture-like finish. The units incorporate the "floor line spread principle" which, it is claimed, keeps the heat down at the floor line or cold air strata. In the blower type units, the Multiflex feature eliminates special outlet nozzles for distributing heat. A Multiflex grille with directional flow louvers is slipped over the outlets and heat is diffused and directed where wanted. The Flexitrol feature allows the automatic opening or closing of one or more of the heat sections so that the air is shut off, thereby eliminating variable speed motors.

Kawneer Store Front Sash

**531M** Only three parts are used in this new type of store front sash:—a self-supporting gutter, an interlocking face member, and a resilient and continuous spring which, when inserted in the gutter, pushes the glass outwardly against the face member. This is said to assure perfect miters and sight lines because the glass is aligned with the face member instead of the gutter. Glass of varying thicknesses may be used on the same job without difficulty since the glass lines up on the outside face. Continuous spring grip giving absolutely even pressure, greater ease and economy of installation, better drainage and ventilation, and self-supporting sash are advantages claimed for this new product introduced by The Kawneer Company, Niles, Mich.

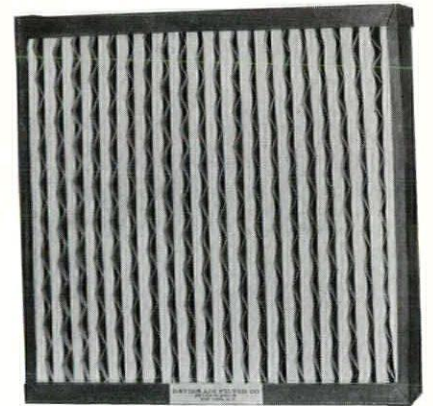
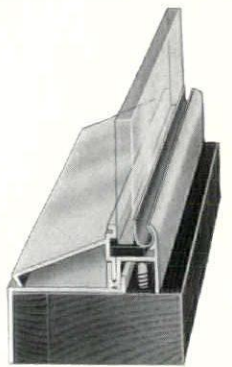

Airplex Air Filter

**532M** Lower resistance, higher efficiency and longer life are claimed for the improved Airplex replaceable dry-type air filter recently developed. The filter medium is a specially processed cotton, lightly glazed on both sides, pleated back and forth eighty times so that over 30 sq. ft. of filter material is contained in a frame 20x20x4". On the air inlet side, strips of netting run the full length of the folds. This netting is not used on the exit side. The pleats are separated by means of corrugated cardboard spacers. The filter medium is designed to operate at temperatures ranging from minus 32 to 200 F and up to 100% humidity. The product is manufactured by the Davis Air Filter Corp., New York.



A P P E A R A N C E • D U R A B I L I T Y • E C O N O M Y

## are Features of Terrazzo

and Alundum Aggregate Adds SAFETY

### NORTON COMPANY

WORCESTER, MASS.

New York Chicago Detroit  
Philadelphia Pittsburgh Hartford  
Cleveland Hamilton, Ont.  
London Paris  
Wesseling, Germany

**T**HIS beautiful foyer in a Municipal Auditorium is typical of the high class jobs for which terrazzo is becoming justly popular. It is also a job in which the terrazzo has been made SAFE as well as attractive. In the monolithically installed floor and the precast treads Alundum Aggregate is assuring permanent walking safety. Even water tracked in on stormy days causes no slipping hazard.

When you are specifying terrazzo take full advantage of its possibilities—make it non-slip with Alundum Aggregate. Send for Catalog C, giving full specification data.

T-427

*Fiftieth  
Norton Year*  
1885 - 1935

# NORTON FLOORS

ALUNDUM TILES — TREADS — AGGREGATES

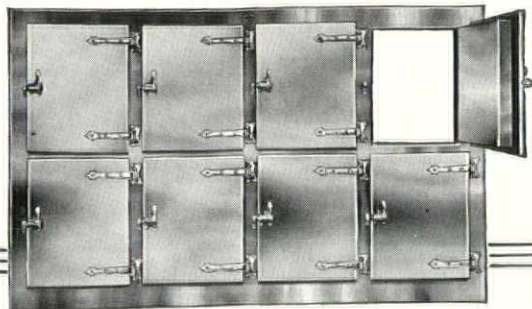

## REFRIGERATOR FRONTS

must harmonize with their surroundings. Jamison-built fronts for use in kitchens, hospital laboratories, stores, institutions, morgues, etc., can be furnished in any design and special finish you specify. And behind this outward beauty is Jamison ruggedness, long wear, ease of operation, and insulation to meet your needs.

For full information, address  
**JAMISON COLD STORAGE DOOR CO.**  
 Jamison, Stevenson, & Victor Doors  
**HAGERSTOWN, MARYLAND, U. S. A.**  
*Branch Offices in Principal Cities*



## How Much Business Will Last Summer's HEAT Bring YOU??

There was a time when nearly every business man felt that he could not avoid losing volume during hot summer months. Even the railroads were losing customers to their competitors—until the railroad coach builders discovered the business-attracting value of genuine—

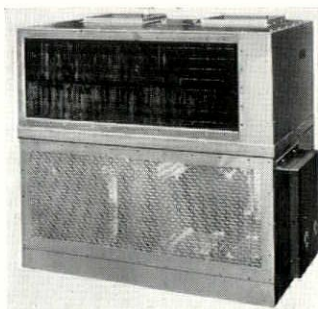
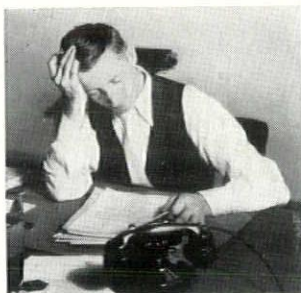

There is a LIPMAN Air Conditioning system of a type and size to meet the needs of any business exactly. Complete and compact, LIPMAN duct or unit type systems can be quickly installed in basement or store rooms. Carefully tested at the factory, LIPMAN systems come all ready to be connected up to water and electric lines or adaptable for specially engineered plans. Send for complete information about LIPMAN Air Conditioning Systems, together with plans for typical installations and charts for estimating requirements.

**GENERAL REFRIGERATION SALES COMPANY**  
 Dept. A-11, Beloit, Wisconsin, U. S. A.

## UTILIZATION VS EXPLOITATION

(Continued from page 41)

Fifth Avenue with all the sanction and protection of the law; but some day this kind of robbery will be illegal.

The Land Utilization Committee of the New York Building Congress has conservatively estimated the surplus residential and commercial space constructed during the last decade at \$740,000,000. \$740,000,000 of surplus space! What could have been accomplished with that amount of money in water-front development, low-cost housing, parks and playgrounds. . . .

Much of the New York water-front constitutes blighted areas; whereas, the water-front in foreign cities—notably Paris, London, Stockholm, Hamburg, Florence, Munich, Geneva and Buda Pesth, are the most beautiful parts of the city. Let no one think that beauty in cities is without commercial value. It has far more commercial value than blighted areas.

Daniel H. Burnham said, "Make no little plans. They have no magic to stir men's blood and probably themselves will not be realized. Make big plans; aim high in hope and work, remembering that a noble, logical plan once recorded will never die, but long after we have gone will be a living thing, asserting itself with ever-growing insistency."

\* \* \*

- In our September issue there appeared an illustration, page 83, of the Cocktail Bar in the Savoy Plaza, New York, for which we gave credit to Walter M. Ballard, as the decorator. This was an error and the credit should have been given to De Wolfe Equipment Corporation, Decorators.

- The Twelfth Semi-Annual Meeting of the Producers' Council, Inc., will be held in Detroit on December 4th and 5th, 1935. The keynote of this meeting will be: Increased co-operation between governmental agencies, financing institutions, architects, builders, and material manufacturers to promote quality.

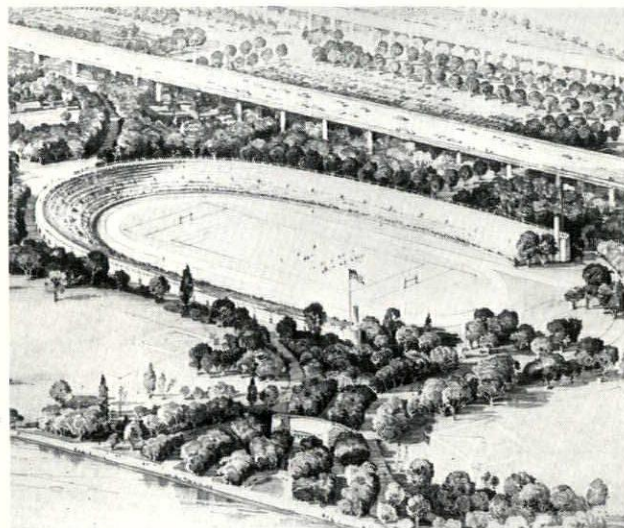

A \$1,000,000 stadium to be erected on Randalls Island in the East River at New York, with relief labor and Federal funds. Maximum capacity will be 45,000



## The Readers Have a Word to Say

(Continued from page 6)

writer is hoping to apply her idea of the "ounce of prevention" insofar as possible without having actually to starve to death.

Why the slum? Somebody gets sufficient worldly wealth to purchase a finer home in a more fashionable or showy locality and prefers "to rent Texas and live in H-11" a la General Sheridan. So that is hard on Somebody's former home if the rent-money to spend in H. is all Mr. S. (or more often his "female relatives") cares about being a good citizen. Can he sell the old home and give someone else with more capital a chance to modernize it or even keep it in as good condition as he tried to keep—well Texas, for example? Kindly ask your readers for information on this subject and I will be very much obliged.—*L. B. Mecutchen, Rochester, N. Y.*

## • THE PUBLIC SHOULD KNOW

Editor, AMERICAN ARCHITECT:

PEOPLE sometimes wonder what the letters "A. I. A." after the name of an architect stand for. Sometimes, but less frequently an architect's name appears with four letters following it, namely, "F. A. I. A." which is still less frequently understood.

The letters A. I. A., of course, refer to the fact that that architect is a member of the American Institute of Architects, the oldest and most conservative architectural organization, and comparable to the "Royal Society of British Architects" of Great Britain.

The letters F. A. I. A. refer to the fact that the architect whose name they follow is not only a member of the American Institute of Architects, but that he has been elected by the Institute to the honorary degree of "Fellowship" in the Institute. Members of the organization are elected to Fellowship by a national jury of Fellows of the Institute only after a very careful consideration of some duration.

Fellowship in the American Institute of Architects constitutes only about 11 per cent of its total membership and less than 3 per cent of the total number of practicing architects in the country. It is the highest honor the Institute confers upon its members and one not given too readily.

It seems to me that it would be a most valuable asset to the members of the American Institute if the public were more fully acquainted with the meaning of "A. I. A." and "F. A. I. A." Some steps should be taken towards this end.—*Herbert B. Biedler, Architect, Chicago, Ill.*

FOR NOVEMBER 1935

## • SLAG BLOCK UNITS

Editor, AMERICAN ARCHITECT:

IN your August issue, on page 64, you show a photograph of the interior of the Tower Theater, Detroit, designed by Arthur K. Hyde. In your description of the photograph you state that paint was used on cinder block. The fact is that the block was slag block and not cinder block.

The slag that we used in making these blocks is a crushed blast furnace slag which we obtain from the local steel mills. The texture of the block is similar to that of a cinder block, but the unit is an entirely different unit. Tests indicate that from a fire resistance standpoint it is probably the best aggregate that can be used.

We should appreciate it very much

if you will have an opportunity of correcting the impression that the units in the Tower Theater are cinder units.—*Benjamin Wilk, General Manager, Standard Building Products Co., Detroit, Michigan.*

## • THANK YOU

Editor, AMERICAN ARCHITECT:

AS a subscriber to AMERICAN ARCHITECT through a period of years, I have been helped by the splendid presentation of views and articles on designing and construction. May I say to you that the issue of August, 1935, particularly appeals to me and I have enjoyed it thoroughly. I should like to have two additional copies of this issue.—*Algernon Blair, Contractor, Montgomery, Ala.*

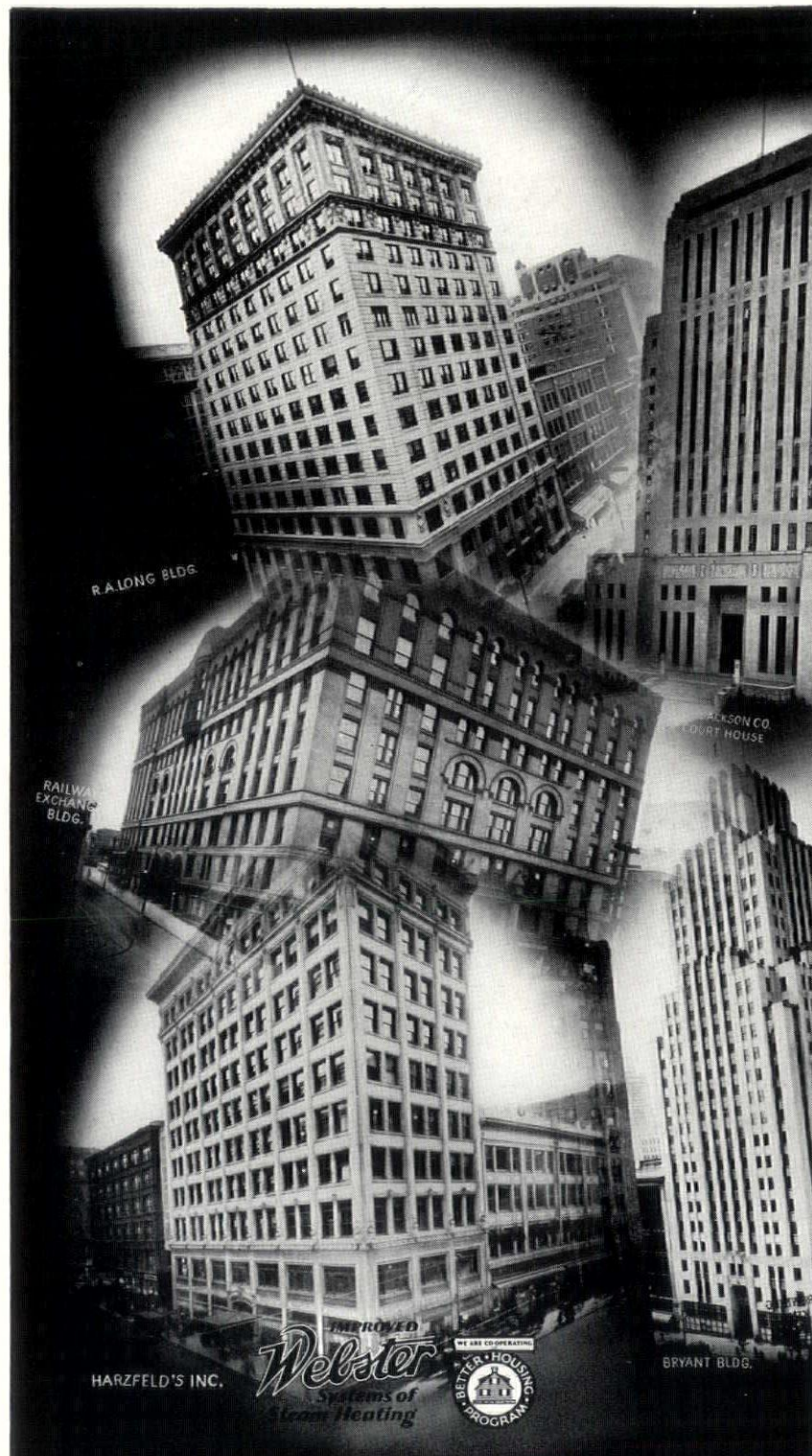

## CUT FUEL COSTS IN FIVE KANSAS CITY BUILDINGS

Webster Moderator Systems  
Give Full Heating Satisfaction  
For Less Money

### SOLVE DIVERSE PROBLEMS

Performance Demonstrates  
Practical Economy of  
Heat Control

### OWNERS WELL SATISFIED

Kansas City, Mo.—Five Kansas City buildings, including the new Jackson County Court House, are securing economical, trouble-free heating service, regardless of outside weather conditions with Improved Webster Systems of Steam Heating.

Despite the fact that vastly different heating problems were encountered in each building, results have been uniformly satisfactory.

In addition to the Jackson County Court House, Webster Central Controlled Systems have been installed in Harzfeld's, Inc., a leading department store, and in three large office buildings, the R. A. Long, the Bryant and the Railway Exchange Buildings.

The Webster Moderator System saved the Bryant Building \$1,204.23 and the Railway Exchange Building \$2,196.21, during 1934-35, the first season after the installations were completed. In four months, at the R. A. Long Building, steam consumption was reduced the equivalent of \$875.26. Between November and June of the 1934-35 heating season, Harzfeld's, Inc., saved \$341.45.

Savings are based on the difference between the dollar value of past and present monthly steam consumption after correction for degree day differences. There was no "starving" of the systems to get results.

In addition to making the installation at Harzfeld's, Inc., where installed direct radiation totals 7,883 square feet, the U. S. Engineering Co. acted as modernization heating contractors in the Railway Exchange and Long Buildings. There are 24,921 and 21,753 square feet of installed direct radiation, respectively, in the latter installations.

The John J. Sherin Plumbing & Heating Company made the installation in the newer Bryant Building, where there is a total of 26,441 square feet of installed direct radiation.

No comparison of fuel costs is possible in the Jackson County Court House, since it is a new building. However, heating service has been adequate during the severest weather and the control equipment has operated to the complete satisfaction of the management. Installed direct radiation totals 28,320 square feet. This Webster System was installed by the Inter-State Heating & Plumbing Company, of Kansas City.

By meeting every heating demand in five separate Kansas City buildings, Webster Systems of Steam Heating have again demonstrated the practical economy of installing effective central heating controls in all buildings, old or new.

If you are interested in (1) improved heating service and (2) lower heating cost in your building, address WARREN WEBSTER & CO., Camden, N. J. Pioneers of the Vacuum System of Steam Heating. Branches in 99 principal U. S. Cities—Estab. 1888

# Wall-thick CAPITOL

ROCK WOOL  
INSULATION

meets

# 5

## Vital Needs

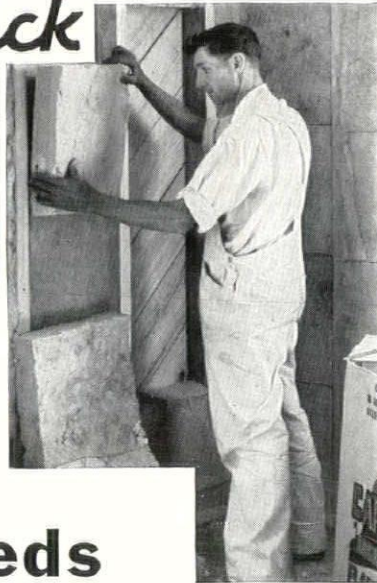

- 1** Saves 80% of the heat otherwise lost in winter through walls and roof. Kills drafts.
- 2** Cuts temperatures 8° to 15° in summer.
- 3** Creates practically uniform temperatures throughout the house.
- 4** Puts fire-proof material under the roof and between the walls. Deadens sound. Moisture-resisting.
- 5** Pays for itself by reducing fuel costs 20% to 35% (permits smaller heating equipment, if desired).

## CAPITOL ROCK WOOL INSULATIONS

Capitol Rock Wool is so easily and quickly handled that it seldom costs more than inferior materials. Manufactured in 15" x 23" bats, it fits between 2 x 4 studding spaced 16" or 24" centers. No wastage; every piece is usable; can be ordered to approximate square footage desired.

It can likewise be applied as readily to existing construction in a blown form. Contractors are available in all cities, licensed to install Capitol Rock Wool Blowing Fibre by our patented pneumatic process.

[ Write for our technical data prepared especially for architects' and engineers' files, covering methods of installing and full details of the insulation efficiency. ]

### MAIL THIS CONVENIENT COUPON

INSULATION DIVISION, The Standard Lime & Stone Co. (Est. 1888)  
First National Bank Building, Baltimore, Md.

Please send us the free Capitol Rock Wool facts on:

- Home Insulation.
- Building or Apartment Insulation.
- Technical Data for Architects or Engineers.

AA-11

Name .....

Address .....

## INDEX TO ADVERTISERS

This index is an editorial feature, maintained for the convenience of readers. It is not a part of the Advertisers' contract and American Architect assumes no responsibility for its correctness.

Aluminum Co. of America.....	99
American Tel. & Tel. Co.....	3
Armstrong Cork Products Co.....	1
Chase & Co., Inc., L. C.....	112
Congoleum-Nairn, Inc.....	91
Crane Co.....	97
Fitzgibbons Boiler Co., Inc.....	102
General Electric Co.....	94
General Refrigeration Sales Co.....	108
Jamison Cold Storage Door Co.....	108
Linde Air Products Co., The.....	7
Nelson Corp., The Herman.....	4-5
Norton Co.....	107
Otis Elevator Co.....	8
Portland Cement Ass'n.....	111
Railway Express Agency, Inc.....	101
Standard Lime & Stone Co., The.....	110
Union Carbide & Carbon Corp.....	7
Vitrolite Div., Libbey-Owens-Ford Glass Co...	93
Webster & Co., Warren.....	109

# Watch Architectural Concrete!



*The Public Market Building at Portland, Oregon, illustrates the distinction lent to commercial structures by architectural concrete. Lawrence, Holford, Allyn & Bean, architects*

## ... IT BRINGS NEW FREEDOM TO DESIGN, NEW ECONOMY TO BUILDING

**T**HE technique of using concrete as a decorative material is advancing more rapidly today than ever before.

It is noteworthy that during the depression, with building in general at its lowest ebb, concrete has established itself as a foremost combined architectural and structural material.

Whatever the function of the building contemplated, concrete lends freedom in design. Recent concrete exteriors of note run the gamut of architectural types.

Concrete is a practical material—consistently

economical in first cost—durable and low in maintenance under the widest range of service and climatic conditions.

To help you design your next building in architectural concrete, let us send monographs covering specifications, construction and design details, and textures. Write us or mail the coupon.

### TOWARD A BETTER PRACTICE

PRACTICAL MONOGRAPHS FOR YOUR FILE

#### PORTLAND CEMENT ASSOCIATION Room 2611, 33 W. Grand Ave., Chicago, Ill.

Please send monographs on architectural concrete. Also  
 booklet, "Beauty in Walls of Architectural Concrete."

Name.....

P. O. Box or St. No.....

City..... State.....

# THE NEW MOHAIR *is your finest* "BUILDING MATERIAL"

**M**OHAIR IS LIKE GOOD MORTAR; sound mohair weaves hold together longer under wear and tear than any other decorative materials ever produced. And as for eye-appeal . . . let the new mohair weaves from the Goodall-Sanford looms show you what that really is!

Here are shadow-sheer casement cloths of mo-

hair. Drapery and non-slip-cover mohairs printed in keeping with every period. Modern textured weaves for upholsteries. Rich velvets and friezes, their beauty protected by a positive moth-preventive process. There is, in fact, the exact mohair for your every need in the largest assortment in existence . . . *Goodall-Sanford's!*



**SWAN** . . . printed mohair for Regency interiors.

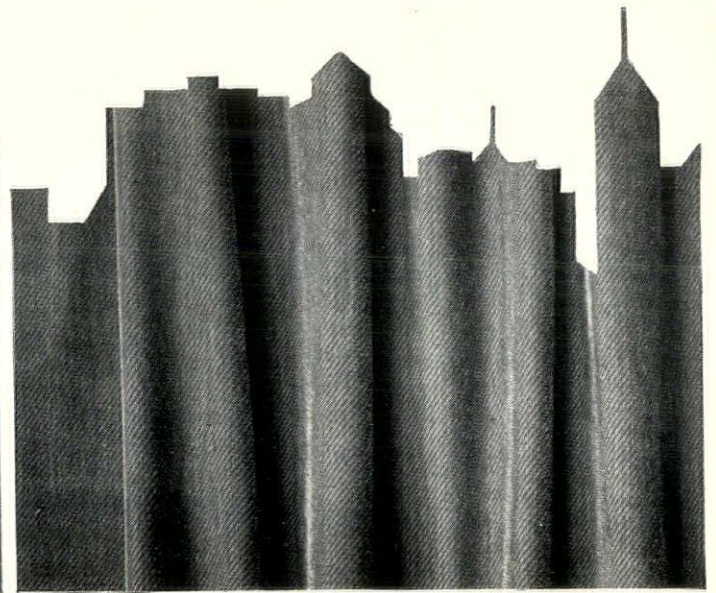

**BETHEL** . . . modern, diagonal weave mohair velvet.

VELMO UPHOLSTERIES  
GOODALL MOHAIRS

**Goodall-Sanford**  
INDUSTRIES

SEAMLOC CARPETS  
LEATHERWOVE FABRICS

L. C. CHASE & CO., Inc., selling division of Goodall-Sanford, 295 Fifth Avenue, New York  
BOSTON CHICAGO DETROIT SAN FRANCISCO

# OUTLINE OF ESSENTIAL TEXTILE PROCESSES

Broadly speaking, textile activities fall into four major divisions: SPINNING, WEAVING, PRINTING, and DYEING. Bleaching and Fulling or Shrinking should be incorporated as necessary factors in the textile scheme.

## SPINNING (Front cover, right)

The most primitive type of spinning device is the distaff and spindle which has been in use since the most ancient times. The hand operated wheel has been used in India (and Persia) for centuries, but not until about the 14th Century was the spinning wheel introduced in Europe. The Jersey Wheel, also known as the "great" or "wool" wheel was one of the early forms; later came the Saxony or Flax wheel, a more complicated mechanism. Paul Lewis applied the first mechanical appliances to spinning in 1732. James Hargreaves, a carpenter, invented the spinning jenny which took 16 spindles; this was about 1764-67. Some suppose that it was named after his daughter, but the female mule is called a jenny, and mules had been used as a power source, so this origin is also possible. Richard Arkwright, about 1768-69, invented a frame that enabled cotton spinning processes to become entirely mechanical; inaugurating an important step in the Industrial Revolution. He was the greatest industrial magnate in England and was knighted by George III in 1786.

Samuel Crompton invented the Spinning Mule in 1774 which, at a single operation, drew, twisted and wound the cotton into a very fine yarn. Poverty and the cost of patenting forced him to sell his rights for 60 pounds Sterling. Later a grant of Parliament gave him 5,000 pounds.

## WEAVING (Front cover, left)

The most primitive loom is simply a taut cord or thong between two posts or trees. Fixed and weighted poles or "warp beams" are used by the Navajos. John Kay invented the Flying-Shuttle in 1733 which greatly increased production. Edmund Cartwright invented the first successful power loom in 1785. Design weaving by power was first successfully accomplished by Joseph Marie Jacquard, who introduced it at the Industrial Exposition in Paris in 1801. In 1806 his loom was bought by the government and made public property. The Jacquard loom is of the greatest importance in modern textile weaving. The basic weaves in loom-ing are Calico (or Plain), Twill, and Satin, from which all other weaves are developed. Directions and relationships of warp and weft are shown in the diagrams.

## PRINTING (Back cover, right)

The printing of textiles is very old. Calico printing is sometimes classified as—1. Block Printing; 2. Cylinder Printing; 3. Resist Printing; 4. Stencil Printing; 5. Discharge Printing. Block printing, the oldest, is

essentially a hand process, though there is a mechanical adaptation of it employing the Perrotine machine which has never come into general use.

In 1770 Thomas Bell came forth with a block printing machine which was not successful, but in 1783-85 he presented his cylinder printing machine which printed from intaglio patterns instead of relief patterns, as in block printing. This made possible printing from one to 16 colors in a single revolution of the cylinder. Oberkampf established at Jouy a printing establishment with J. B. Huet in charge in 1760 which lasted until 1811 and marked the peak in cotton printing as a decorative art. Resist or reserve printing employs a mechanical or chemical "resist" (as wax in batik work) which keeps the parts treated free from color. Discharge printing through use of chemicals removes color leaving a white pattern on a dark ground as in bandanas. Stencil printing which has reached a high degree of perfection and artistry in Japan has the pattern cut in an opaque, color-resisting material such as heavy paper, and the color is painted on with a brush to make the design.

Bleaching processes may be applied to the raw material before it is spun into thread or after weaving into cloth. Primitive bleaching by exposure to the sun and dew in open fields is still in use and according to some writers still the finest method. It is sometimes combined with chemical bleaching.

## DYEING (Back cover, left)

Until comparatively recent times, dyeing was done with natural dyes, not with artificial or synthetic dyes. Natural dyes are obtained from vegetable, animal and mineral sources. Madder root, Alizarin, Indigo, Logwood are examples of vegetable dyes,—Cochineal, Kermes, Tyrian purple (from a snail) are animal dyes,—Ocher and Prussian blue are mineral dyes. They have been almost entirely replaced by the synthetic dyes most of which have a coal-tar base. Dyes are direct (dye in color as actually seen) or mordant (dye dependent on the kind of mordant used—Alizarin, for instance, yields various colors depending on the mordant used).

Artificial Prussian blue was invented in 1710. A. W. von Hoffman identified Aniline as a product common to various sources, indigo, nitrobenzine and coal-tar (from which nitrobenzine comes). Runge discovered, in 1834, the principle of aniline dyeing, but it remained for Sir William Perkin to produce the first actual aniline dye. A vast field of chemistry was opened. In 1868 the first artificial Alizarin was produced by Graebe and Liebermann, important because it is the first synthetic reproduction of a vegetable dye. In 1878 Baeyer produced Artificial Indigo.

ERNEST BORN

DYES ARE CLASSIFIED AS NATURAL AND ARTIFICIAL OR SYNTHETIC

VEGETABLE • ANIMAL • MINERAL

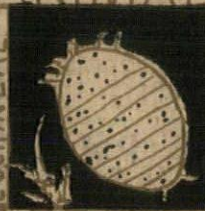

# PRINTING

FIRST PRINTED TEXTILES PROBABLY IN INDIA - IN EUROPE ABOUT 17<sup>TH</sup> CENTURY



BLOCK PRINTING IS OLDEST

1518 - FIRST COCHINEAL COMES TO EUROPE FROM MEXICO

1710 - PRUSSIAN BLUE

1834 ANILINE PRINCIPLE BY RUNGE

1856 FIRST ANILINE DYE PERKINS

1770 - BELL - ENGRAVED PLATE PRINTING

1783 - BELL - CYLINDER PRINTING

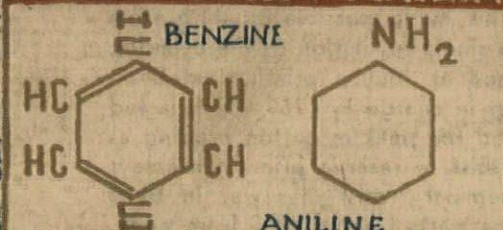

LANCASHIRE DYE JIG

BENZINE THE FOUNDATION OF THE ANILINE STRUCTURE

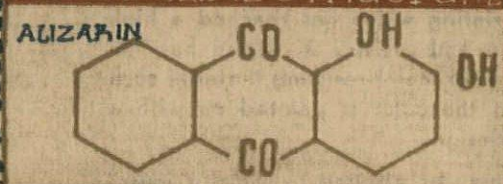

ALIZARIN GRAEBE & LIEBERMANN IN 1868 PRODUCTION FIRST ARTIFICIAL VEGETABLE DYE

1878 BAEYER ARTIFICIAL INDIGO EXPERIMENTS ON SPECTRUM

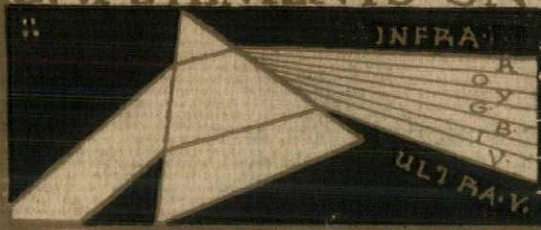

BEGIN MODERN SCIENTIFIC COLOR STUDY SIR ISAAC NEWTON 1666

OBERKAMPF JOUY 1760-1811 BY HUET DESIGNS

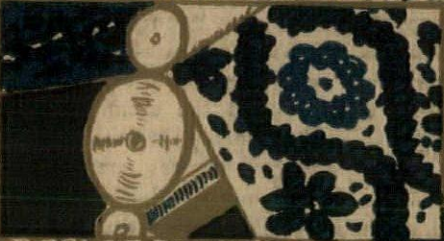

RESIST PRINTING WAX IS A RESIST IN BAIK



DISCHARGE



JAPANESE ART MASTER STENCIL PRINTING



BLEACHING

CROFTING OR GRASS BLEACHING STILL IN USE

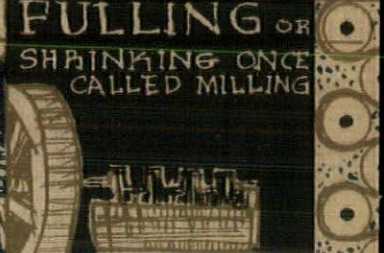

FULLING OR SHRINKING ONCE CALLED MILLING

PESTLES & FULLER'S EARTH IN VATS

# DYEING

FOUNDED 1876

# AMERICAN ARCHITECT