

Oct 71

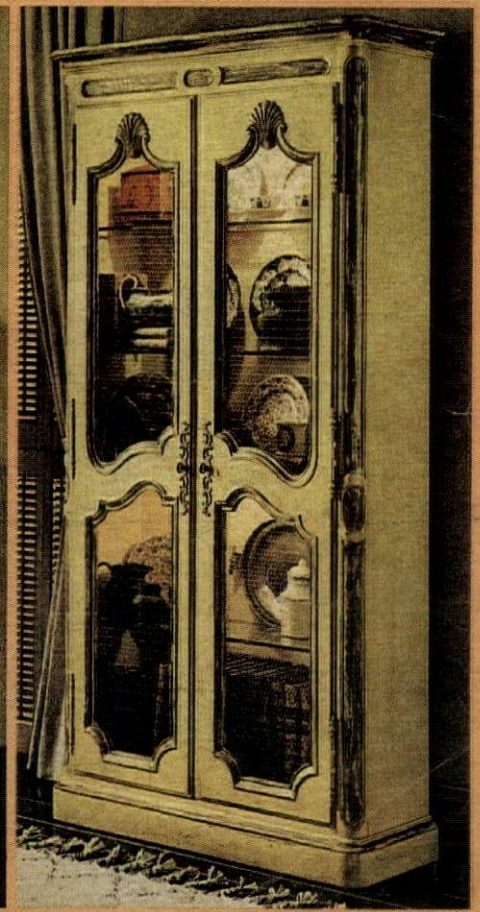

Henredon's Four Centuries Collection... French country styles from the past translated into modern American.

From the reign of Louis XIII until the beginning of the Republic, the French designed furniture that endures in beauty right up to today. And Henredon has recaptured it in their Four Centuries Collection. This is the furniture of the French countryside, of the chateaux where the living was sophisticated, but more casual and freer than city life.

Four Centuries is faithful to that feeling... It is robust, natural, yet always elegant. It can be light or massive in scale, delicate or bold in detail. For example, the bookcase or china cabinet shown on the right with its sturdy upright shape, open grillwork panels, and adjustable shelves contrasted with its delicate shell carvings.

Four Centuries is for bedroom, dining room, or living room—and always for people who enjoy their home and furnishings. For complete brochures, including upholstered furniture, send \$1.00 to Henredon, Dept. HG 10-71, Morganton, North Carolina 28655.

Henredon

PERIODICAL
S
NA7100
HG
140
no. 4
U.H. LIBRARY

The Pleasure Principle

As long as you're going to spend the money for a good scotch, why not spend a little more and get a great scotch.

J&B RARE
The Pleasure Principle

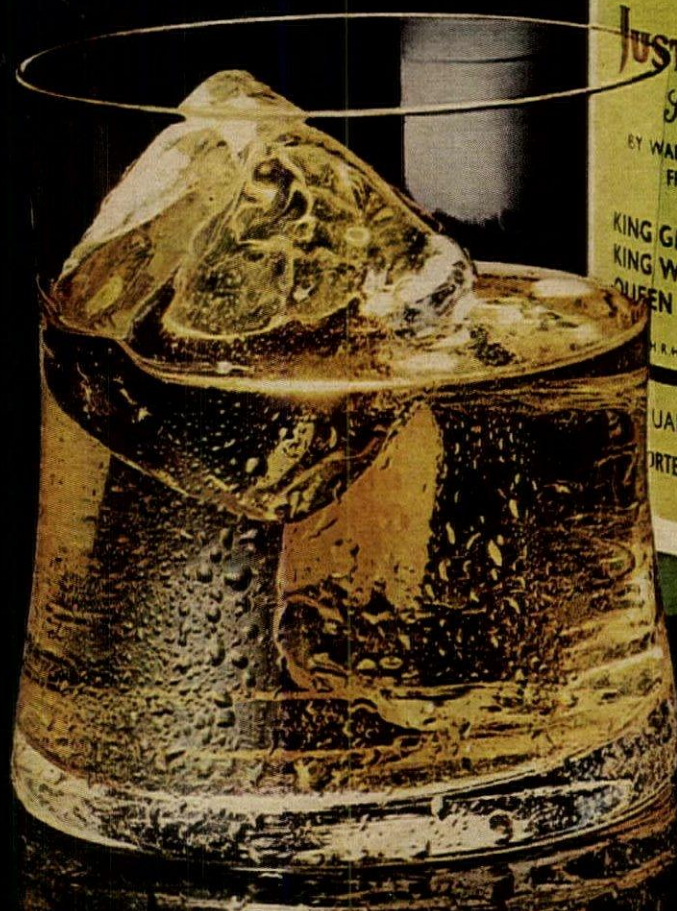



A new generation should create its own traditions. Introducing Golden Aegean Weave.

Wallace created Golden Aegean Weave sterling for people who want to express their individuality. Establish their own traditions.

Golden Aegean Weave has a warm, natural simplicity. Its long, smooth rounded stems, contrasted by a textured basket weave, are bordered by four delicate golden bands. Dress it up for company next to gold-rimmed china or mix it with more casual china for a "just us" occasion. It's graceful. Elegant. Refreshingly unique.

(Golden Aegean Weave is sterling silver with electroplated gold bands. Also available without gold trim.)

Golden Aegean Weave isn't just a beautiful new sterling pattern from Wallace. It's the beginning of a tradition that will probably last forever.

**WALLACE
STERLING** 

House & Garden

INCORPORATING **LIVING** FOR YOUNG HOMEMAKERS

PERRY L. RUSTON, CHAIRMAN

ALEXANDER LIBERMAN, EDITORIAL DIRECTOR



HORST

On the cover: A deep Venetian red that goes lighter and more orange in sunlight sets up Susanna Rattazzi's New York dining-sitting room in rich lacquer gleamings achieved with lots of coats of both paint and lacquer. Our cover shows the hanging-around part of the room with its wonderful combinations of modern fabric and old furniture, plants, a modern table and tiny TV. The Louis XV bergère is covered in African inspired cotton print. Other elements: beige suede ottomans, an Edwardian armoire of straw and bamboo, a green lacquer table by Karl Springer, rug by David Hicks. To see more of this carefree mixing of color and texture, find out how Countess Rattazzi worked with her team of decorators see pages 116 to 123.

OCTOBER, 1971

VOL. 140 NO. 4

Decorating, Architecture, Building

- 8 A decorator speaks his mind: How to be an expert with pattern *by William Baldwin*
- 38 The loveliest rooms I've ever seen *by Cornelia Conger*
- 85 How do you bring your rooms up to date for living now? (*Editorial*)
- 86 Fifty pieces of furniture for living now and how you can decorate with them in new ways
- 100 The great change in living values—a conversation with Jack Lenor Larsen and Robert L. Schwartz
- 102 Clean-sweep space for living now: Everything in one enormous room
- 104 Big look in not-very-big rooms
- 108 Nonstop rooms
- 116 One woman's adventures with her three decorators *by Susanna Rattazzi*
- 126 For living now—a house next to nature
- 149 Building facts
- 152 Ingenious ways to turn one room into two

Entertaining

- 18 Thoughts for the hostess *by Mary Moon Hemingway*
- 130 Corkscrew: Your liquid assets—drinks for parties
- 131 House & Garden Cook Book: Four great Christmas recipes—a lesson with James Beard

Decorate-it-yourself

- 70 Notes to help you decorate-it-yourself *by Patricia Corbin*
- 124 The art of burnished gilding—an Isabel O'Neil fantasy finish
- 150 How to make a slipcover like an expert

Gardening

- 76 A gardener speaks his mind: A walk with perennials *by William B. Harris*
- 112 The very personal garden of the Emilio Pucci: Land art—a garden carved into the earth
- 224 Gardener's notes *by James Fanning*

Beauty and Health

- 46 Some notes on good looks & good health *by Rebecca Warfield*

Kitchens and Housekeeping

- 52 Notes of a happy housekeeper *by Mary Elizabeth Falter*

Features

- 31 Art for everybody: An interview with Charles Cowles *by Mary Roche*
- 72 Questions & answers: Antiques *by Louise Ade Boger*
- 85 How do you bring your rooms up to date for living now? (*Editorial*)
- 100 The great change in living values—a conversation with Jack Lenor Larsen and Robert L. Schwartz

Reader's Service

- 144 Shopping information
- 149 Building facts
- 156 Shopping around with Betty Fagan
- 228 Best in booklets

EDITOR-IN-CHIEF
MARY JANE POOL

MANAGING EDITOR
MARY ROCHE

ASSOCIATE EDITORS
DENISE OTIS MIKI DENHOF

ART EDITOR
G. WOODFORD PRATT

DECORATING
**JACQUELINE GONNET
SUZANNE MORRIS
KAAREN PARKER**

HOME FURNISHINGS EDITOR
HERMINE MARIAX

FURNITURE-DESIGN PROJECTS
**MARGARET KENNEDY
PETER NEIL** ASSISTANT
AUDREY NICHOLS SILVER-CHINA-GLASS
JOYCE MACRAE FABRICS-WALL COVERINGS
DEANE B. WOLFE ASSISTANT
MEG MUNDY THURROTT FLOOR COVERINGS
BED-BATH READY-TO-USE DECORATING

ARCHITECTURE-BUILDING
WILL MEHLHORN

TRENDS-ENVIRONMENTS
ELIZABETH SVERBEYEFF

KITCHENS-EQUIPMENT
BARBARA PORTSCH EDITOR
JOYCE DICK

ENTERTAINING-SPECIAL PROJECTS
GALEN BRAND

COOK BOOKS-CORKSCREW
**JANE BACON ELLIS
PENELOPE JOHNSON** ASSISTANT

GARDENS
MARYBETH LITTLE WESTON EDITOR
RUTH CRANSTON

DECORATE-IT-YOURSELF CRAFTS
PATRICIA CORBIN

SPECIAL FEATURES EDITOR
BEVERLY RUSSELL

CONTRIBUTING BEAUTY EDITOR
REBECCA WARFIELD

COPY EDITOR
KENNETH BATES

TRAVEL-SPECIAL ASSIGNMENTS
NANCY MCCARTHY

ASSISTANT MANAGING EDITOR
**JEROME DENNER
PENUAL ALLAN** ASSOCIATE

ART DEPARTMENT
**HOWARD SPERBER
PATTI MADIGAN
LINDA M. RATH**

ADMINISTRATIVE COORDINATOR
LORNA DAMARELL CAINE

CONTRIBUTING EDITORS
PRATT WILLIAMS NEW YORK
JOSÉ WILSON
KATHERINE MEEHAN
JOAN GARDNER WASHINGTON
DOROTHEA WALKER SAN FRANCISCO
MARILYN SCHAFER
GWENDOLYN WARNER SANTA BARBARA
LOUIS J. GARTNER PALM BEACH
MARGARET WYLLAUMEZ
BETTINA MCNUITY LONDON
MARIE-PIERRE DE CICCIO PARIS

EXECUTIVE EDITOR
ANNETT JOHNSON

MERCHANDISING
SALLY DOUGHERTY

SHOPPING AROUND
BETTY FAGAN EDITOR

ASSOCIATE PUBLISHER
HENRY H. HOLMES

ADVERTISING DIRECTOR
JOSEPH L. FUCHS
ADVERTISING MANAGER
VERNE E. WESTERBERG

PROMOTION DIRECTOR
LEONA L. SILLS

NEW ENGLAND
Stallier Building, Boston, Mass., 02116
DAVID J. MOORE

CHICAGO
875 North Michigan Avenue
Chicago, Ill., 60611
JOHN H. REOCK

CLEVELAND
Bulkley Building, Cleveland, Ohio, 44115
R. J. BIESMEYER

ATLANTA
1371 Peachtree Street, N.E.
Atlanta, Ga., 30309
LOUIS M. FRICK

PACIFIC COAST
3921 Wilshire Boulevard
Los Angeles, Calif., 90005
TED KRAL

FLORIDA
150 Southeast 25th Road
Vizcaya Towers
Miami, Fla., 33129
ROBERT E. YOST
The Dawson Company
5995 S.W. 71st Street
South Miami, Fla., 33143

SOUTHWEST
Roy McDonald Associates, Inc.
3130 Southwest Freeway
Houston, Tex., 77006
Roy McDonald Associates, Inc.
Stemmons Tower West
Dallas, Tex., 75207

SHOPPING AROUND
420 Lexington Avenue, New York, N.Y., 10017
GERARD CARONARA

BRITISH HOUSE & GARDEN
Vogue House, Hanover Square, London, W.1

FRENCH HOUSE & GARDEN
(Maison & Jardin)
4 Place du Palais Bourbon, Paris 7

POUL HORNSTLETH, PUBLISHER

HOUSE & GARDEN IS PUBLISHED BY THE CONDÉ NAST PUBLICATIONS INC.

COPYRIGHT © 1971 BY THE CONDÉ NAST PUBLICATIONS INC. ALL RIGHTS RESERVED. PRINTED IN THE U.S.A. HOUSE & GARDEN INCORPORATING LIVING FOR YOUNG HOMEMAKERS IS PUBLISHED MONTHLY BY THE CONDÉ NAST PUBLICATIONS INC., 420 LEXINGTON AVENUE, NEW YORK, N.Y., 10017. SECOND-CLASS POSTAGE PAID AT NEW YORK, N.Y., AND ADDITIONAL MAILING OFFICES. SUBSCRIPTIONS: IN U.S. AND POSSESSIONS, \$7 FOR ONE YEAR, \$12 FOR TWO YEARS, \$16 FOR THREE YEARS. IN CANADA, \$8 FOR ONE YEAR, \$14 FOR TWO YEARS, \$19 FOR THREE YEARS. ELSEWHERE, \$9 FOR ONE YEAR. PAYABLE IN ADVANCE. SINGLE COPIES 75¢. FOR SUBSCRIPTIONS, ADDRESS CHANGES, AND ADJUSTMENTS, WRITE TO HOUSE & GARDEN, BOX 5202, BOULDER, COLORADO 80302. SIX WEEKS ARE REQUIRED FOR CHANGE OF ADDRESS. PLEASE GIVE BOTH NEW AND OLD ADDRESS AS PRINTED ON LAST LABEL. POSTMASTER: SEND FORM 3579 TO HOUSE & GARDEN, BOX 5202, BOULDER, COLORADO 80302.

FOR FURTHER INFORMATION ABOUT ANYTHING APPEARING IN THIS ISSUE, PLEASE WRITE HOUSE & GARDEN READER SERVICE, 420 LEXINGTON AVENUE, NEW YORK, N.Y., 10017.

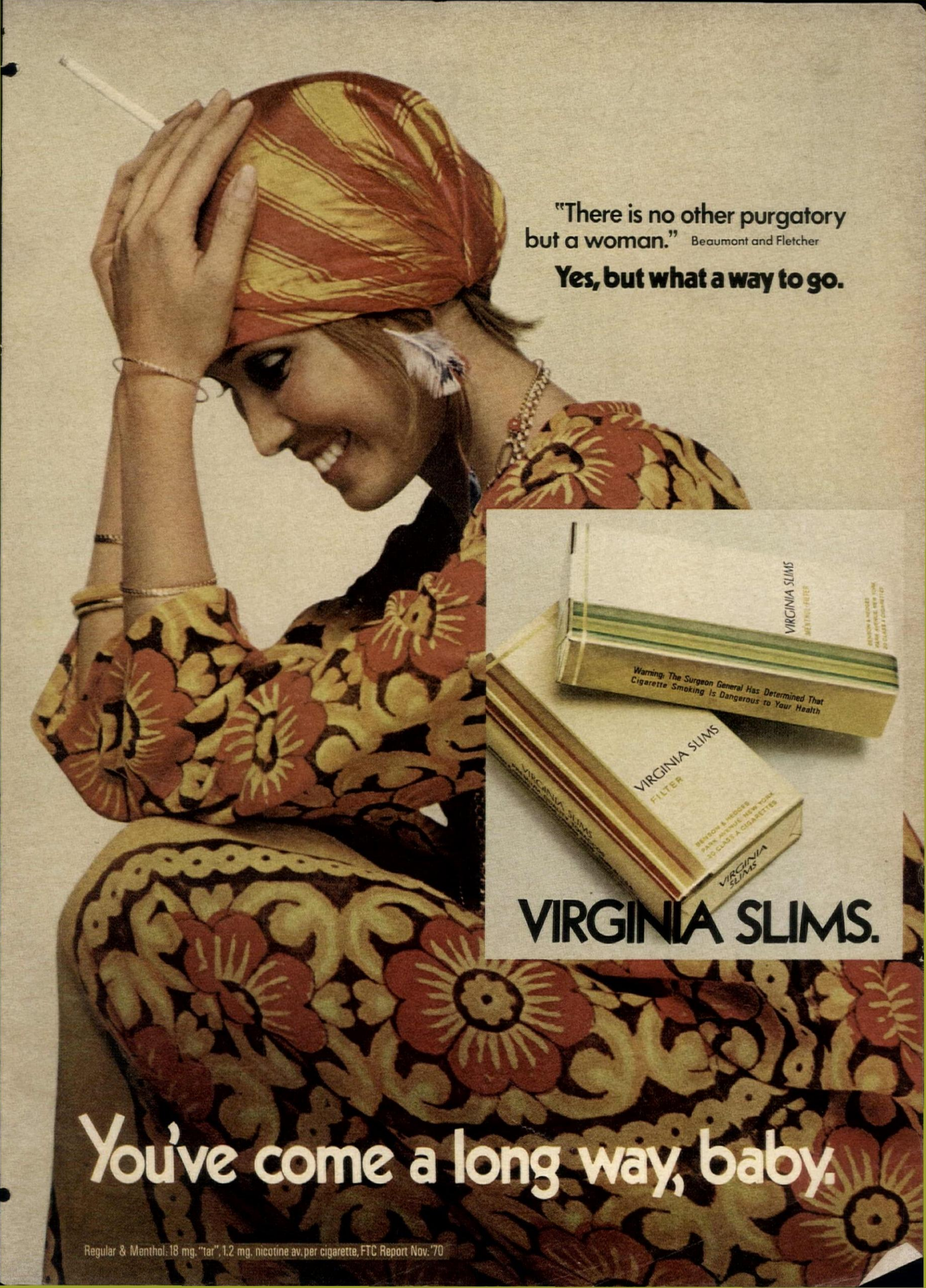

"There is no other purgatory
but a woman." Beaumont and Fletcher

Yes, but what a way to go.

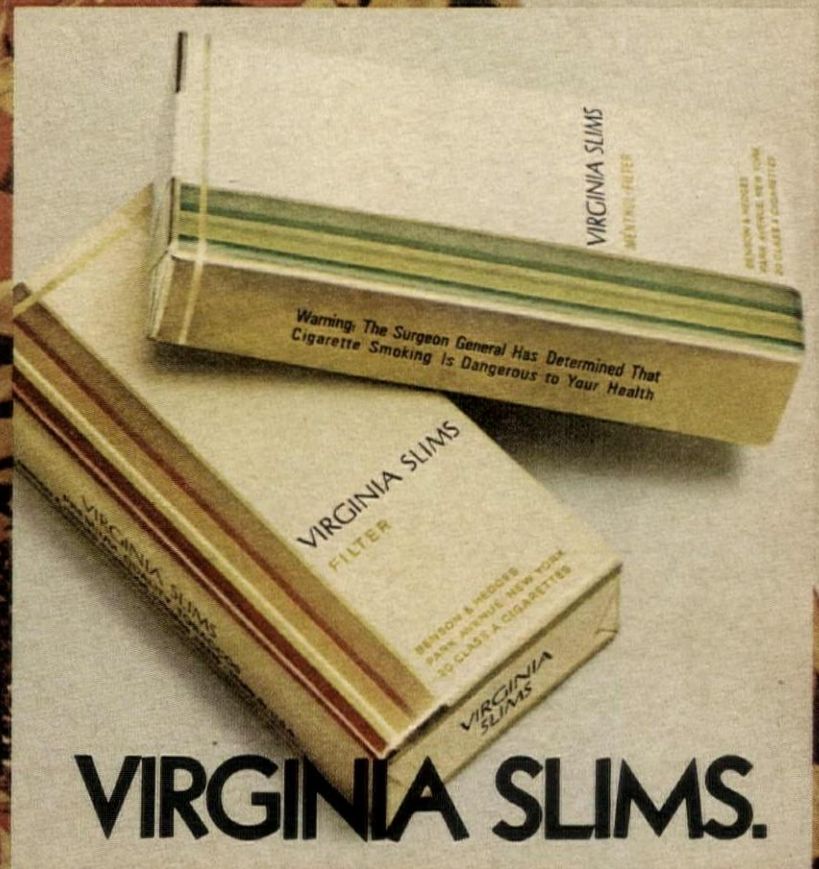

VIRGINIA SLIMS.

You've come a long way, baby.

Old lamps for sale.



In a real sense, the lamp in the center is several hundred years old. It was inspired by the stately church candlesticks created in Spain and Italy during the early Renaissance. Finished in distressed old brass, it is 37½ inches tall and costs about \$95. A perfect example of the way Stiffel makes an old lamp young again.

At left, a classical Georgian urn accented in black enamel. This Stiffel is 39½ inches tall, costs about \$99.50, and has the detail and craftsmanship needed to support the longevity of its design.

In the late Renaissance period, Italian artisans were creating oil lamps such as the one to your right. Using bright old brass finish and electricity, Stiffel artisans have updated this classic. The finished piece stands 38 inches high and costs about \$99.50.

To know more about the Stiffel collection, send 25¢ to The Stiffel Company, Dept. G, Chicago, Illinois 60610. You don't even have to hurry. Our lamps will be in style whenever you get around to writing.

Prices may be higher in the South and West.

Stiffel



It's the \$100 chair inside our \$400 chair that makes it a better buy than any \$300 chair



You can buy a chair that looks just like ours, but costs \$100 less. And for a while you'd think you had a bargain.

Then one day, you'd sink into it and there'd be a lump where you expected kindness. And soon the curve you like to rest your head on would begin to droop.

Now, if you'd invested another \$100 and bought our chair instead, it would keep its curves and comforts long enough to become an heirloom.

Because we use that \$100 difference to put an extra chair inside our chair. A chair composed of extra springs secured with extra webbings, so the seat never sags under the sitter. Extra layers of padding held down with extra stretches of burlap, so the stuffing stays where you need it. No lumping ever. Extra curves carved into the framework for a wood base that will last. (We don't just pad our chairs into shape—we build the shape in at the start.)

When you're buying a new chair, you can't tell—just by sitting—how much sitting you'll get from it. Unless it has the name Heritage on the outside, to guarantee that you're also getting the essential extra chair on the inside.



HERITAGE

Furnishings Group / U.S. Plywood-Champion Papers Inc.
Furniture by Drexel / Heritage / Meadowcraft / Carpet by Trend

For a catalog of our upholstered pieces, plus some other Heritage collections, also a helpful room planning kit, send \$2 to Dept. UL, Heritage Furniture, High Point, N. C. 27261

How to be an expert with pattern

By William Baldwin

In Paris recently, I saw a freshly decorated room with a great collection of antique French chairs. To update them, their intricately patterned tapestry covers had been replaced with plain-colored satin ones. A friend of mine, a woman with marvelous taste, saw the finished room too. "It is obviously very expensive, but an utter bore," she said. "It is absolutely patternless. There is nothing for your eye to feed on."

Pattern-on-pattern is nature's way

In my own experience, I have learned that to omit pattern from a room is to leave it looking flavorless. "Lots of pattern makes a room too busy," protest novices, not sure of themselves. They forget pattern-on-pattern is nature's way.

In small rooms pattern has an intimate quality

In decorating, there are two ways I use pattern: a little or a lot. When you use a lot, you create the currently popular pattern-on-pattern room, where practically no surface is left untouched by pattern of one sort or another. Such clutters of pattern look best in small rooms, because small rooms and lots of pattern have the same kind of intimate quality about them.

When I decorated Kenneth's salon in New York, I didn't draw a blueprint calling for pattern-on-pattern, but that's the way it worked out. The allover patterns in reds and golds just happened to create the kind of atmosphere we were looking for: coziness, feet-up relaxation, a place where a woman would feel coddled the moment she stepped through the door. Pattern-on-pattern has a way of doing that.

Large rooms need a little pattern for spice

In a larger room, so much pattern would be either dreary or so overpowering it would knock you down. In such rooms, I like clean, open spaces, expanses of fresh clear colors, and a little pattern for spice. In a blue and white room I did in France, the pattern is limited to rugs, ottomans, sofa cushions, and a collection of Chinese porcelains. If you were to eliminate any of the pattern, the room would look rather antiseptic. But any more pattern would be just too fussy.

Continued on page 16

When the Queen of England wanted bone china for her wedding table, she chose Aynsley.

The Queen had her choice. And she chose Aynsley. It's that good. Take *Henley*, it pictures the perennial bloom of an English garden of flowers. \$28.95, five-piece place setting.

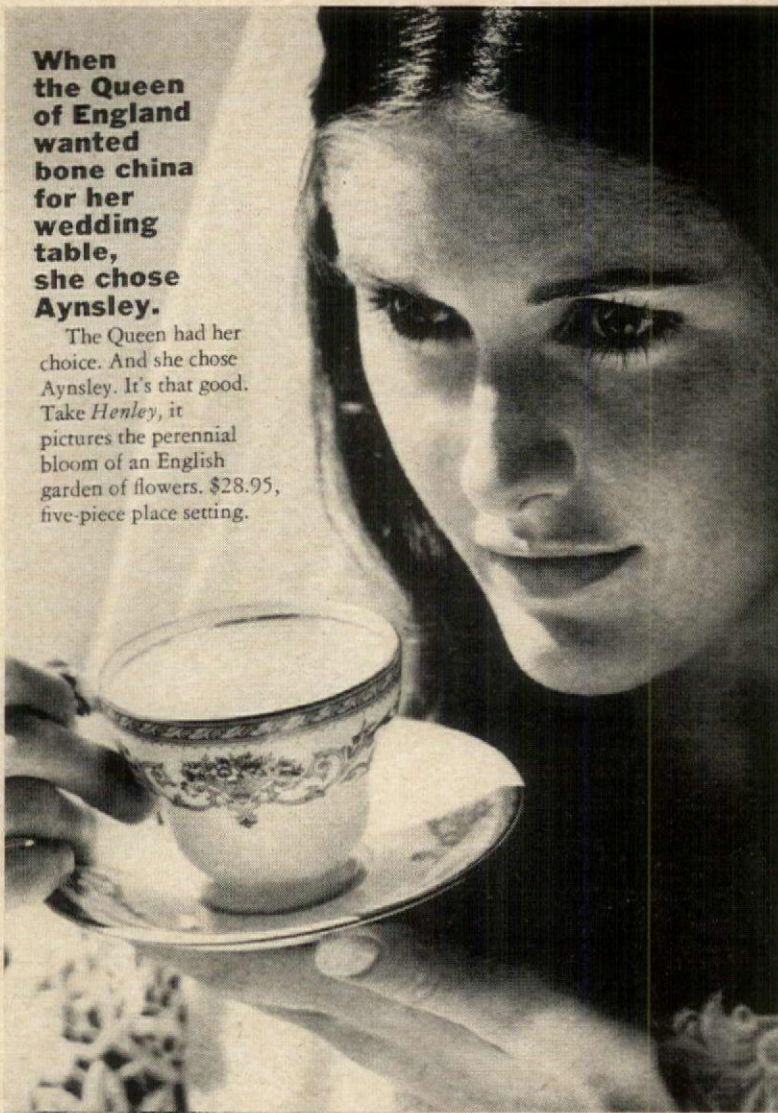

And when the president's daughter wanted crystal, she chose Waterford.

The *Alana* goblet, made by hand with heart, is a signed original, as is each piece of Waterford Crystal. \$12.

For free brochures on how to wine and dine happily ever after, write to Aynsley & Waterford, 225 Fifth Ave., N.Y. 10010.

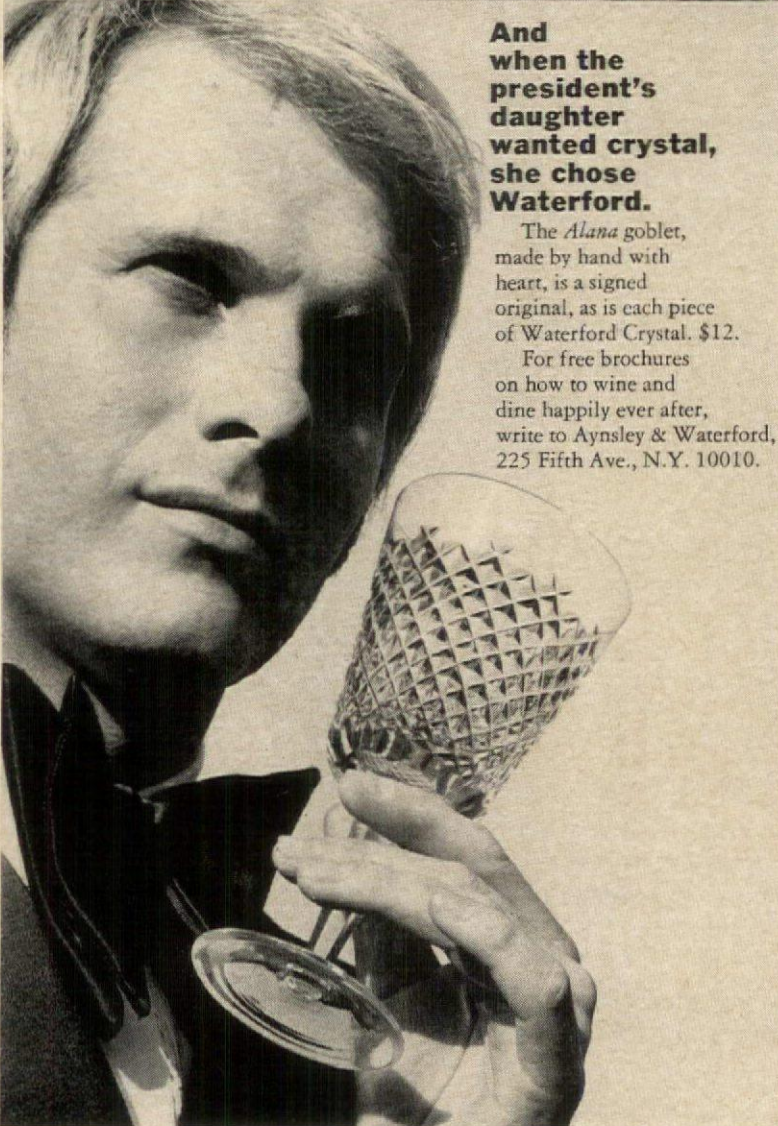



Gypsy Caravan

A dramatic collection of decorative fabrics and wallcoverings



Available through interior designers and at fine stores everywhere

SCHUMACHER

F. Schumacher & Co. • 939 Third Avenue • New York, N.Y. 10022

PROTECTED WITH
DURABLE
ZEPEL
STAIN REPELLER

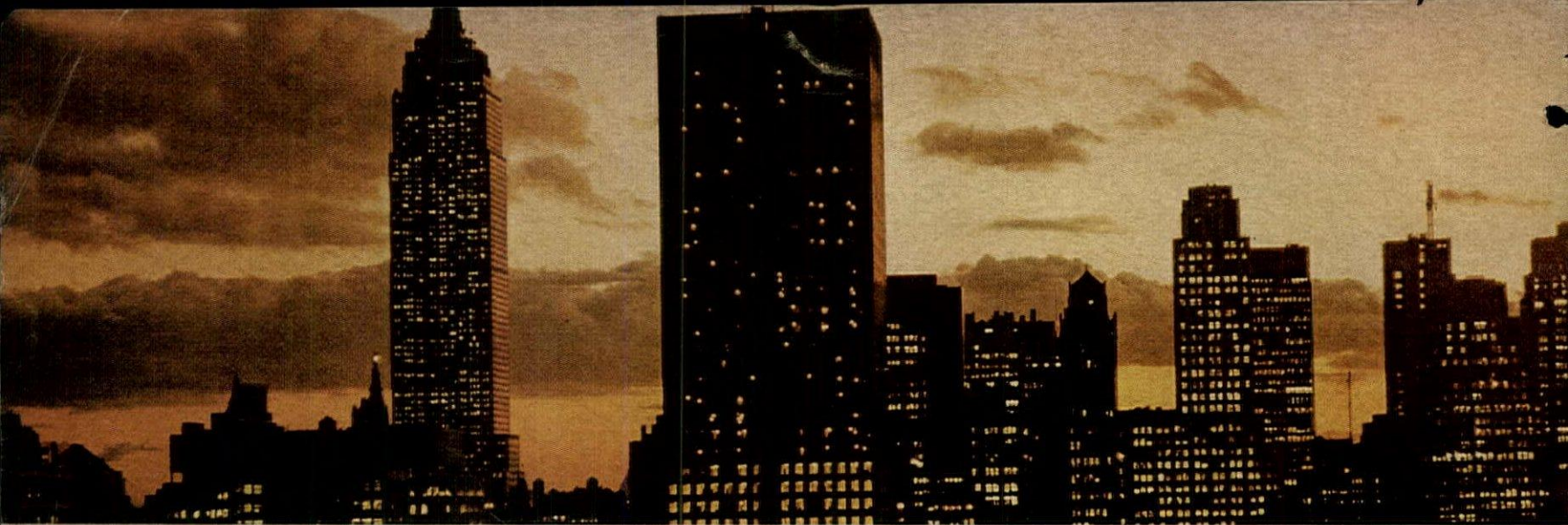

The new Bill Blass Collection for Springmaid creates a penthouse environment in your home.



From the new Bill Blass collection for Springmaid—a tweedy, tailored, totally new look for bed and bath. Inspired by the casual clean-edged elegance of a penthouse apartment, the Tweed scheme is handsome enough for a man to feel totally at home with, chic enough for a woman to love. The ensemble, in a classic tweed with tweedy plaid accents, includes no-iron Wondercale sheets

and pillowcases of 50% Kodol® polyester and 50% combed cotton, no-iron cotton hopsacking bedspread, sheared cotton terry towels, and co-ordinated shower curtain. All are also available in navy.

For the store nearest you, call no charge any time: (800) 631-1971. In New Jersey, (800) 962-2804.



SPRINGS MILLS, INC., 104 WEST 40th STREET, NEW YORK 10018



Now, his kind of whiskey,
has your kind of smoothness.

Get to know a beautiful new taste—the taste of Four Roses Premium. It's lighter than the lightest Scotch, smoother than the smoothest Canadian. Plus a subtle note of friendly American flavor. The kind of taste you can start with, and stay with.

We suggest you try Four Roses Premium on the rocks, with a little water. See if you don't agree that there's never been a whiskey like it.

New **Four Roses Premium.**
You've got to taste it to believe it.



AMERICAN WHISKEY • A BLEND • 86 PROOF • 75% GRAIN NEUTRAL SPIRITS • © 1971 FOUR ROSES DIST. CO., N.Y.C.

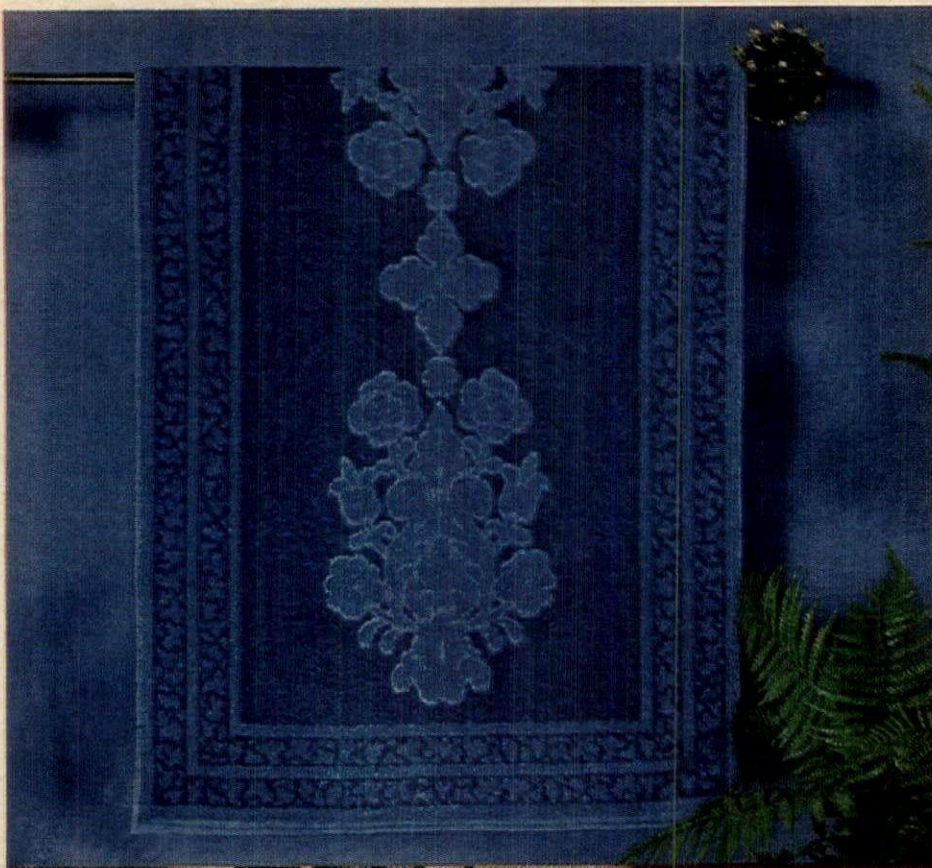

*When you know what you want to do with your bath, isn't it nice to find **DUNDEE** has done it?*

An exciting collection of fine bath beauties to fit your most exacting decor. SUSSEX, a sheared jacquard in blue, gold, green or pink about \$2.50. FLOWERTIME, a sheared print on solid ground, in pretty floral combinations of blue, pink and lemon about \$2.00. FLEURETTE, sheared solid in blue, pink, white and lemon with color coordinated Schiffli embroidery about \$2.50. At department stores everywhere. **DUNDEE**

Dundee Mills Inc., 1075 Ave. of the Americas, New York 10018. Mills at Griffin, Georgia • Towel makers since 1888.

MENUS FOR A WHOLE YEAR OF DINNERS

YOURS FOR ONLY \$1 (Plus postage and handling)

This big \$8.95 volume is your no-obligation introduction to the new Good Housekeeping Book Club

As a member you need never purchase another book from the Club unless you want to

Here at last is a book club that's frankly feminine — with the same wide range of interests as the modern American wife and mother. Interests that range from home decorating, gardening, cooking, sewing, to a lively concern with what's going on in the community, the country — the world.

As you know, up to now there has never been a book club edited—as Good Housekeeping magazine is edited—especially for women, a club that really knows what a woman's life is all about. But now the Good Housekeeping Book Club will feature books that cover subjects on everything from stretching your household dollar . . . health and beauty . . . hobbies and crafts . . . travel . . . cooking and entertaining . . . diet pills and LSD . . . to modern sex research and what it has to say about happiness in marriage.

Accept this beautiful new cookbook, and you'll never again need to say: "what shall I have for dinner tonight?"

Here's a book that gives you a complete dinner menu, with recipes and tips, for every single day of the year—and every recipe has been evaluated and approved in Good Housekeeping's own kitchens!

You'll find menus for family meals, holiday meals, company meals. In fact, menus for every conceivable dinner you'll need to prepare all year!

There are menus to help you stay on your budget; menus you can prepare ahead and have ready in a few minutes; menus that include dishes you can bake together; menus planned for a minimum of cleanup. And there's a quick-reference index you can use to pick out a recipe that fits the bargain your favorite food store is advertising!

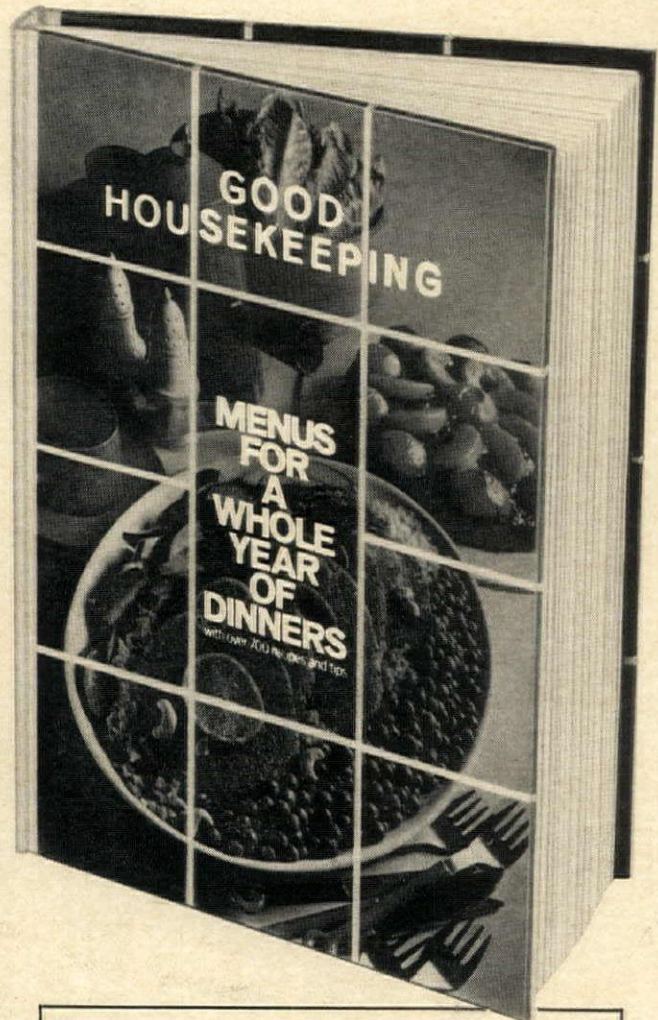

Menus For A Whole Year of Dinners is yours for only \$1.00 simply to introduce you to the Good Housekeeping Book Club. Simply return the membership coupon at bottom and we'll enroll you as a member, send you Menus For A Whole Year of Dinners, and bill you for just \$1.00, plus postage and handling.

After seeing it, if you aren't delighted, simply return it and owe nothing.

As a member you'll receive a monthly notice of the Club's current selection and alternates which you may accept only if you wish at member's low prices that will be 20-30% less than book store prices. If you do not wish any book, you simply return the convenient "No thank you slip" and nothing will be sent. As a member you are under NO OBLIGATION to purchase a single volume ever. We offer you this \$7.95 savings as an introduction to the Club.

SO DON'T DELAY—MAIL THE MEMBERSHIP COUPON TODAY!

GOOD HOUSEKEEPING BOOK CLUB
P.O. Box 2317, F.D.R. Station, New York, N.Y. 10022

C281

Please enroll me as a member of the Good Housekeeping Book Club, send my copy of *Menus For a Whole Year of Dinners* and bill me later for just \$1.00 plus a small charge for postage and handling. After receiving my copy of *Menus For a Whole Year of Dinners*, if I am not delighted, I may return it within 10 days. That will cancel my membership and I will owe nothing. I understand that, as a member, I will receive about every month, advance notice of the latest Club book selection. If I do NOT wish to receive a selection, or if I prefer an alternate book instead, I will let you know promptly by returning the convenient form which always accompanies the advance notice. I understand that if I DO wish to receive the monthly selection I need do nothing and it will automatically be sent. As a member I need never purchase a single additional volume and may cancel my membership at any time.

Name _____ Please Initial _____
Please Print
Address _____
City _____
State _____ Zip _____

Available only in U.S. and its possessions. © 1971 The Hearst Corp.

Most women ruin their carpet before it's ever installed in their homes.

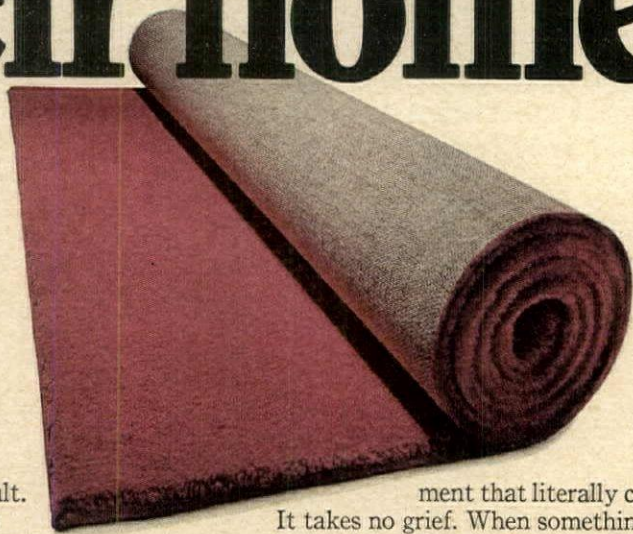

And it's not even the woman's fault. The culprit is: The cushion. When you settle on cushion, you start your carpet's ruin.

Carpets wear out when the backing breaks down. And the backing breaks down when it doesn't get even support from the cushion. Cushions, you see, do a lot besides cushion. They crumble, collapse, smell and even disappear under certain conditions.

But don't blame the carpet salesman. Cushion is all he's had to sell till now.

Now there's carpet foundation.

Omalon™ Carpet Foundation. A patented* new develop-

ment that literally can double a carpet's life. It takes no grief. When something pushes down, Omalon pushes back. Evenly. That goes for 100 pound televisions, 200 pound husbands, 700 pound pianos, anything that tries to make a lasting impression.

In short, Omalon won't crumble, collapse, smell or disappear. So neither will your carpet.

For the nearest Omalon dealer, call this special number free—800-243-6000. In Conn. call 1-800-942-0655.

But before that write Dept. OM at the address below for a free booklet. And leave the cushions to things they belong with. Like couches or pins.

For nearest Omalon dealer call toll-free 800-243-6000.

omalon.TM
PATENTED CARPET FOUNDATION
BY **Olin**



*Produced under patented process. Olin U.S. patent no. 3506600. Olin Corporation, Dept. OM, 120 Long Ridge Road, Stamford, Conn. 06904 OMALON™ is an Olin Corporation trademark



Solid oak so strong it's guaranteed.



GUARANTEED for as long as you own it. Because we make furniture for the active family room life. With frames of solid oak. Shaped from oak beams up to 5" thick. Mitered and doweled by hand.

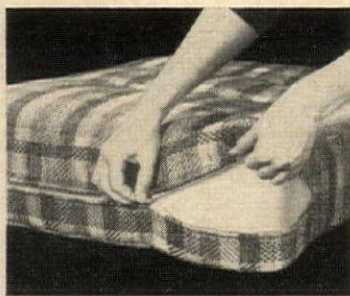

We guarantee you won't break it for as long as you own it.

Howard cushions are deep solid foam wrapped in soft polyester. Reversible for longer life. Covers are zippered for removal and spot cleaning.

As any cushions and covers, they *will* eventually wear out. But a whole new set for a Howard chair costs less than reupholstering an overstuffed chair.

And the point is, the chair will still be with you. More beautiful, as the golden oak takes on added luster. And always oak tree strong. It proves that beautiful furniture *can* be built to last a lifetime. But only if you design it for strength as well as for beauty.

And the price is reasonable.

About \$600 for sofa, chair, cocktail table and end table. In colorful **HERCULON*** fiber upholstery with stain release built in, not added on. With the matching pieces to make one big happy family room. Table and chair sets, bars, stools, rockers, love seats, wall units for storage and occasional chairs.

For pictures and the name of your dealer send 25c to Howard Family Room Furniture, Starkville, Mississippi 39759.

HOWARD® family room furniture

BACCARAT CRYSTAL ... since 1764

CERALENE CHINA ... in the distinctive French tradition

CERALENE CHINA ... imported from Limoges, France

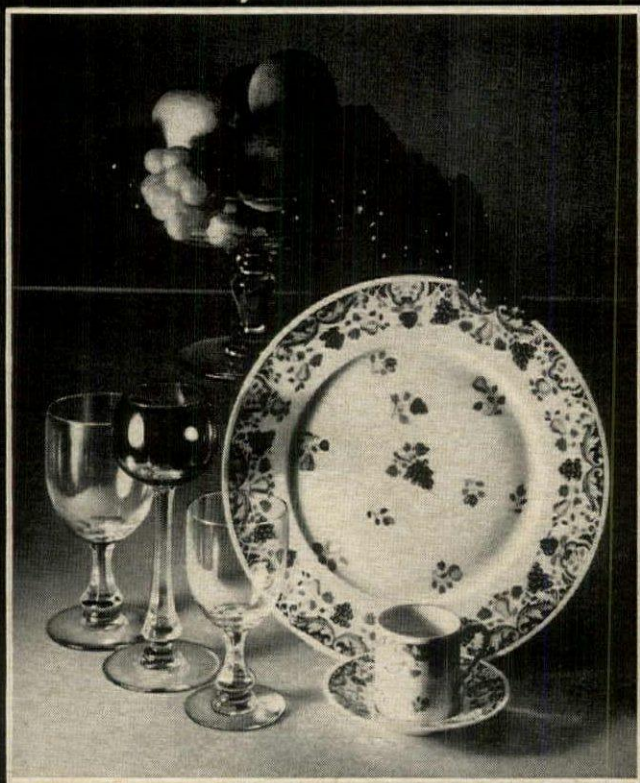

The GASCOGNE stemware pattern in full-lead crystal by BACCARAT, created in 1890, sturdy and classical, is \$9 per stem. The Rhine wine glass is \$19. The gay, colorful china is FIESTA, made by RAYNAUD & Cie. in Limoges, for CERALENE. It is inspired from an original in the museum in Strasbourg, circa 1735. The five-piece place setting, \$42.50.

at fine stores and at
BACCARAT
55 East 57th St., N.Y.C.

Write Dept. HG15 for brochures featuring stemware, china or gifts, 25¢ ea., and/or \$1 for "How to Choose and Use Wine Glasses."

PATTERN *continued from page 8*

Whichever way you use pattern, the one great pitfall to avoid is timidity. Many women, in a burst of decorating energy, will put up patterned walls, patterned curtains, patterned furniture, then screech to a halt and install plain wall-to-wall carpeting.

Have the courage to go the limit with pattern

You must have the courage to go the limit with pattern. Have a figured carpet or a stenciled floor, or at least the regular, monotone pattern of waxed quarry tiles. And for good measure, heap that flowery sofa with cushions—dozens of them—in lots of tiny prints.

One day I was sitting with a friend in a room I had decorated. We were just relaxing and talking, when suddenly she exclaimed, "Do you realize there are eight different patterns in this room?" Well I didn't realize it. I had to start counting. It certainly was not a pattern-on-pattern room. The walls were white, the floor a dark brown tile. There were wooden shutters instead of curtains—no pattern there. And the biggest pieces of upholstered furniture were covered with cream-colored linen. But grouped around the fireplace was a cluster of little chairs, benches, and stools, and sure enough, each was covered with a different cotton print.

A good blend is what counts

When I was working on the room, the patterns seemed so natural that I didn't even realize I was using so many. Looking back, I can see that if the little chairs had been covered instead with plain fabric, the room would have looked somehow "unseasoned." There would have been a noticeable gap that only pattern could fill. To have covered them all exactly alike would have been a bore. Needless to say, these patterns were not overpowering or everyone would have noticed them instantly. They were all in the same tawny shades of brown, cream, and black. They were all tiny—either regular little flowers or sharp geometrics. Yet they were by no means pallid or nebulous. They were crisp and bold. It was just that they blended so well into the room as a whole that they did their job inconspicuously.

The only way you can really learn how to use pattern is by training your eye. Get yourself accustomed to looking at good pattern-on-pattern, and let your eye, rather than your mind, absorb the way patterns relate to each other. Take a look around. It will suddenly strike you that the whole world is pattern-on-pattern. Spend some time at a gallery or even with a few books on Oriental and Middle Eastern art or decorating or even fashion. The Japanese, Arabians, Indians, and their neighbors are experts with pattern, putting the most exciting prints together with artless perfection. *Continued on page 142*

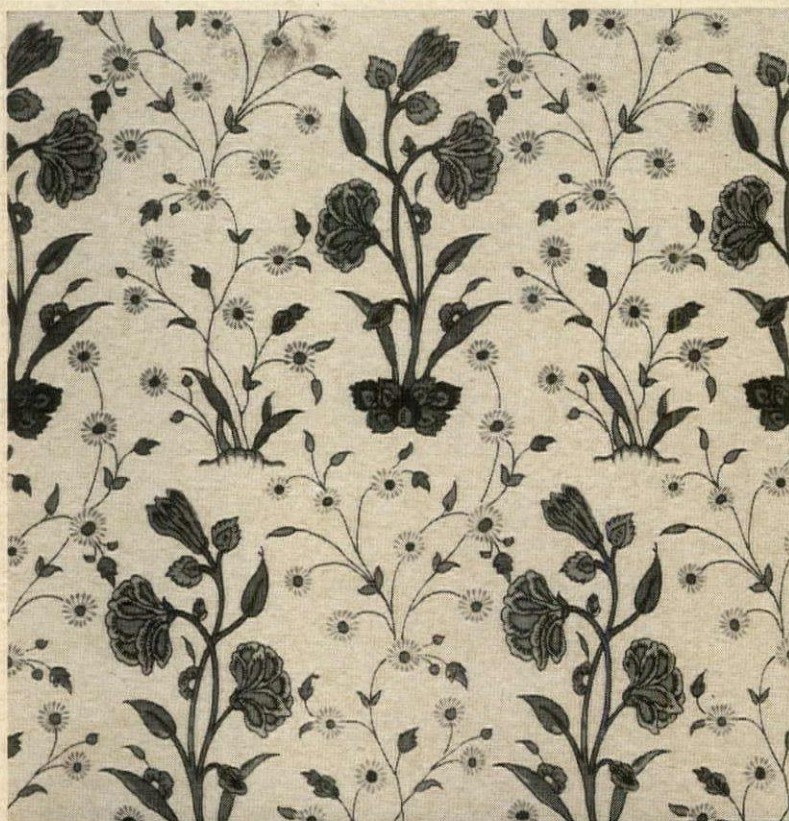

REGINA—A cotton and linen print from a naive 18th-Century "India Chints."

Brunschwig & Fils

Decorative Fabrics and Wallcoverings

979 THIRD AVENUE NEW YORK 10022

Philadelphia • Boston • Chicago • Los Angeles • San Francisco • Seattle • Dallas • Houston • Paris

Available through your interior designer and decorating departments of fine stores.



Shades of the Tiffany look!

When Mr. Tiffany first saw those pagoda umbrellas shading Oriental royalty, he went home and designed a lampshade. You loved it. We loved it, too. But it's been around a while. So now Sears takes the look of open-weave cane and bamboo, and updates the Tiffany!

Table lamps, floor lamps, chain lamps. All U.L. listed. With opal glass globes and walnut-finish columns. Sensational! They'll add something special. A shade that actually decorates a room.

The Cane Collection. See it now at most larger Sears, Roebuck and Co. stores, and in the catalog.

The Cane Collection. Only at **Sears**

Free booklet helps you find the best home values.

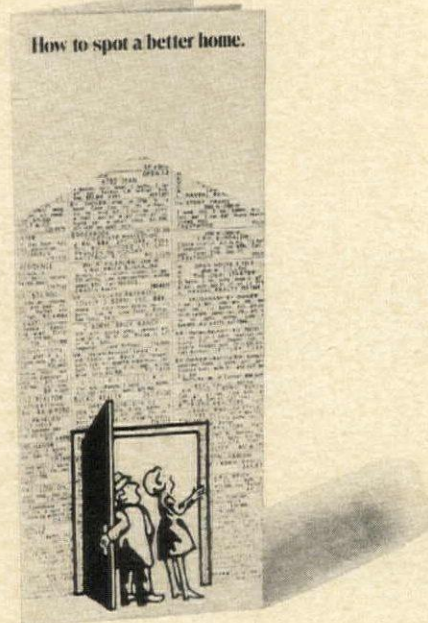

This free pocket-sized booklet includes 16 important things to consider (including quality wood windows and wood panel doors) when you look for a new home or apartment. They'll help you avoid major pitfalls later and get the most for your money now. Send for it today. It's absolutely free.

Please send me your free booklet, "How to Spot a Better Home."

Name _____
 Address _____
 City _____
 State _____ Zip _____
 hg

 **Ponderosa Pine** Woodwork
 39 S. La Salle Chicago, Ill. 60603

THOUGHTS FOR THE HOSTESS

BY MARY MOON HEMINGWAY

Two, four, six, eight . . . the parties I appreciate right now after a summer of expansive, fairly unstructured entertaining are the get-togethers with a few friends for an intimate meal. A splendid *dinner for two* is a great way to honor your spouse on his birthday or just for instance. I like to choose an attractive spot for a small table, some place more special than the dining room, then deck the table with nostalgia, i.e. wedding presents. The menu would include not only my husband's impossible-for-a-party favorites but a fancy surprise as well. Tokens of my appreciation might include oysters on the half shell with a superlative white wine, steak *au poivre*, soufflé potatoes, snow peas cooked at the last minute, an excellent burgundy, and for the unexpected, a Grand Marnier soufflé and more Grand Marnier.

For a foursome, I would not be such a slave to the culinary clock. Instead I'd plan an evening of bridge, Scrabble, any four-way game we can share with friends and follow this with tray suppers served right at the gaming board. Perhaps eggs baked with mushrooms or chicken livers; Caesar salad mixed at the table, popovers (they can be made ahead and reheated), and a Kirsch-laced fruit compote with gaufrettes on the side.

A party for a half dozen can be staged in the kitchen, the guests enjoying cocktails and conversation while the cook or cooks concoct. This allows for some interesting digression from the usual as host and hostess can be, theoretically, in two places at once. A perfect setup for Chinese cuisine, a kitchen party is also practical for a serve-immediately Austrian supper—Wiener schnitzel, fried parsley and spaetzle accompanied by Gumpoldskirchner, with a *kaiserschmarren* as the sweet. And an excellent solution for bouillabaisse or fondue. For an innovation try a *fondue de veau*, substituting cubes of veal, calves' liver, and kidneys for the beef. Or an Oriental fondue, for which you use cubed lamb in boiling meat stock instead of oil, and offer curry sauce, chutney, and any other Indian side dishes you like along with rice.

Dinner for eight seems to me to be just about the right number for good talk, good food—a number that can be handled with easy elegance even if you have no help. For such a dinner I enjoy doing everything with a flourish—the whole gamut from place plates to finger bowls, if I can get a waitress. If not, a gloriously photogenic buffet on the sideboard to be served by host and hostess. When on my own I might serve a mushroom broth—mushrooms cooked in chicken stock then whirred in the blender—from a handsome tureen in the living room. That would give me a chance to set up the rest of the dinner: possibly a cook-in-advance, enjoy-it-now menu of salmi of duck, a ring mold of mixed wild and white rice, zucchini filled with puréed peas, and babas au rhum as a finale. Carafes of vin rosé set in wine coasters at both ends of the buffet would be pretty and facilitate serving.

Granted good food is fundamental to a good party, there are parties with other points of interest. A friend of ours recently held *an evening auction party* at her house, each of the

Continued on page 20

Select your favorite *Surety* Dacron/Linen tablecloth at your nearest May Company store and branches.

MAYCO CALIFORNIA
 Los Angeles, Calif.

FAMOUS-BARR CO.
 St. Louis, Mo.

the **MAY** co.
 Cleveland, Ohio

KAUFMANN'S
 Pittsburgh, Pa.

The *Hecht* Co.
 Baltimore, Md.

Meier & Frank Co.
 Portland, Ore.

G. FOX & CO.
 Hartford, Conn.

ONEILS
 Akron, Ohio

MAY-D&F
 Denver, Colo.

The *Hecht* Co.
 Washington, D.C.

Strouss'
 Youngstown, Ohio

MAY
Cohens
 Jacksonville, Fla.

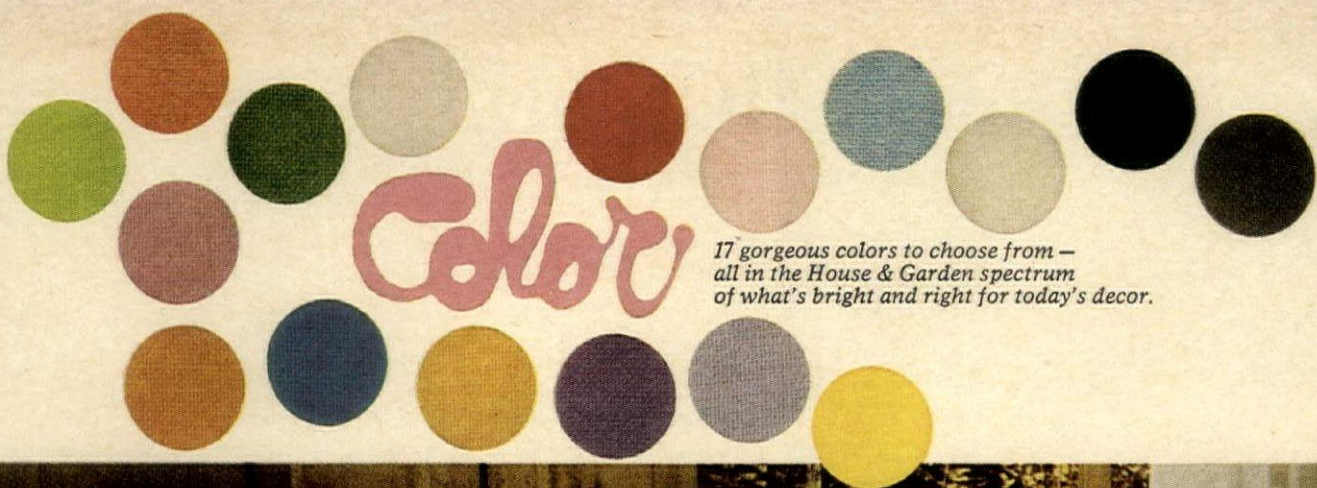

17 gorgeous colors to choose from —
all in the House & Garden spectrum
of what's bright and right for today's decor.



For beauty and the feast

Capture the holiday spirit with this care-free, easy-living Dacron Polyester/Linen *Surety* tablecloth. Remarkably talented! No-ironing. Machine washable. Soil-releasing. Its beauty will brighten your festivities year after year . . . and never a worry.

Sizes to suit your setting: from 52" x 70" to 60"/120" oblong or oval, and rounds. Select napkins in matching or contrasting colors. All at the May stores listed opposite.

© Du Pont Registered Trade Mark

Surety

Dacron® 75%/Linen 25%
Permanent Press,
Soil Releasing Tablecloth

Dacron®

By Du Pont



When it comes to
designing better kitchens,
we wrote the book.

It's yours for \$2.

If your new kitchen is still in the dreaming stage, you'll want to pause over the many idea-pictures and room arrangements to see how we've turned kitchens into exciting rooms for other smart women.

If you're just about ready to get your new kitchen, you'll want to read a typical case history to see the many ways a St. Charles dealer/designer can help you plan your kitchen, interpret your ideas, and save you time and effort.

You'll find a full panorama of decors and finishes in this full color, 44-page folio—contemporary, traditional, provincial, classic, and country stylings—all distinctively St. Charles. So send in \$2 today for your folio and find out why St. Charles Custom Kitchens have earned the reputation of being the most distinguished kitchens money can buy.

St. Charles CUSTOM KITCHENS
613 Tyler Road, St. Charles, Illinois 60174

Enclosed is \$2. Send me your full color, 44-page folio on St. Charles dream kitchens.

We plan to: Remodel Build



Name _____ (Please print)

Address _____

City _____ County _____

State _____ Zip _____

THOUGHTS FOR THE HOSTESS

continued from page 18

guests having brought some treasure to be auctioned off, the proceeds going to a mutually admired cause. The auctioneers were friends endowed with the appropriate talents. Other guests came the day before to help receive donations and tag them descriptively. In lieu of dinner—the auction started at nine—finger sweets and dessert wines were served after the last bid was in.

Anyone who has been to an antique show lately knows that **pewter is it**. To set a whole table with old pewter would be prohibitively expensive but that's no reason to forgo the pleasure and gleam of pewter. International Silver Company is now producing good-looking stemware—goblets in three sizes and small cordials as well. If you're a real pewter buff you can match the stemware with plain pewter dinner plates from the Woodbury Pewterers. For the weekend house, such a table setting would be both impressive and unbreakable. Combined with china or glass, pewter makes a nice change, and stainless steel flatware has a happy affinity for it.

My old Chinese sectional sweetmeat dish has delighted me for years, serving cocktail tidbits as it does with beautiful self-containment. Today you can buy reproductions, but right now I am rejoicing in a less formal **variation of the sweetmeat dish**—a handcrafted mahogany lazy Susan, carrying six mahogany bowls, the center one with a cover. Extremely tidy for snacks, marvelous as well for fondue sauces, six-boy curry, breakfast garnishes, ice cream toppings. Carefully made in Puerto Rico, the set may also be had with an ebony or walnut finish.

Now that the days are getting shorter and more light needs to be shed on every subject, **a candle at each place setting** would not be amiss—a pretty symbol of sharing warmth and light. For the fun of it and for informal illumination, you can get a combination napkin ring and candle holder. Consists of a wrought-iron ring topped by a tulip-like holder for a gourd-shaped candle that comes in a riot of colors, pale to passionate.

Have you ever thought:

Of all the possibilities of pumpkin beyond jack-o-lanterns and pie? Soup, soufflé, mixed in a cake, baked like squash.

Of dressing and cooking a leg of lamb with pineapple? You can baste it with the juice from the can now that pineapple is packed in its natural juice.

Of making "melba toast" with fingers cut from English muffins? Crunchy, lovely with pâté.

Of supplying both linen and paper napkins when the food is to be picked up with the fingers? Linen for the lap, bright paper for the fingers. Good answer to boiled lobster or chicken in the basket.

Of updating the old punched-cardboard needlework motto? Design one yourself, sentiment and all, and work it in wild colors as a house present.

Of sending out invitations to a bon voyage party on big luggage tags?

Of keeping a hostess diary to record not only the guest list, menu, and decorations, but the highlights, quotes, and mood of the party?



... Burlington—th
... and socks and pantyh
... ington House, the widest col
... ever offered under one
... years in the home furnishings b
... made our first bedspread forty years
... seen how lost most people feel when s
... to buy things for the home. After all, the



Burlington House
... should be the nicest place you ever go.

BURLINGTON INDUSTRIES, 1345 AVENUE OF THE AM

Art for everybody

BY MARY ROCHE

EDITOR'S NOTE: Charles Cowles, who was born in California and grew up in New York, started to collect art while a student at Stanford University. In the beginning he bought many prints, and his first contemporary object—a steel assemblage by Robert Hudson—is still one of his favorites. You will see others on the walls of his new apartment, page 102. For the past six years he has been publisher of Artforum.

Art in one form or another seems to be more easily available to more people today than ever before—do you agree?

Definitely. Between prints and originals and the number of people who are creating art today, it really is available to everyone in every price range. If you can't afford to spend \$5,000 or more for a painting by a prominent contemporary artist, you can perhaps afford to pay \$1,000 for the work of a young unknown or \$100 for a contemporary print.

And the supply?

New galleries are springing up every day. Every time I drive through the side streets of New York I see galleries I've never heard of before. At the same time there are some 50,000 people living in New York who call themselves artists. Well, if you say there might be a hundred reputable established New York galleries, each handling twelve to twenty-four artists, that means there might be 2,400 artists who are recognized. What happens to the other 47,600? For every artist who becomes well known, famous, in vogue, there are probably ten others who are painting exactly the same way. Some may be copying but some are achieving the same styles and techniques on their own. Many artists who are quite competent paint all their lives and never receive recognition. It's a matter of the art world being overpopulated. So you can seek out and find a young artist that you feel confident is doing good art, and you can buy his work to support him, or for your own aesthetic pleasure.

Is it best to buy through a dealer or gallery or directly from the artist?

If the artist has a dealer, it becomes a matter of integrity to buy through him, or at least the artist is obligated to pay him a commission. There is also a better chance that the artist is going to become successful if he has a dealer. But if you feel that you have the eye—the ability to pick a good painting from an artist who has no dealer—go right ahead.

Once you get away from New York, how do you find artists and galleries?

If you're lucky enough to live in a community where there's a reasonably decent museum, watch its activities. See whose work is being shown on a local level. Try to become active in the museum and your activity will make available a certain amount of guidance from the staff. Just because you or I or someone else has never heard of an artist doesn't mean

anything. But you should be aware of the fact that for every semirespectable gallery there are ten that are not.

How do you explain the sudden mushrooming of "Soho," New York's downtown art neighborhood?

It's mainly a matter of space. Soho had been developed after the Civil War as an industrial area but most of the small firms who had been renting lofts there had either folded or moved outside the city. The area had become depressed. Artists were attracted to it because there they could get enough space to work in at a fairly reasonable cost. Meanwhile rents uptown where most of the galleries were located had in some cases doubled. And with artists painting larger and larger canvases, the galleries needed more space too. After all, if you want to look properly at a painting 10 feet square, you have to get back 20 or 30 feet from it. So now there are nineteen galleries in Soho. More going on of course brings more people down there—also you have such a wide price range because of the many new artists. I moved downtown myself because I had more paintings than I could possibly hang in my apartment uptown and I didn't think it was fair to myself or to the young artists whose works I owned to have them stuck away in storage. Now I can really live with them and enjoy them. I rotate them regularly—about once a month.

Would you recommend prints as a good starting point for first-time art buyers?

Certainly. Most of today's greatest artists are doing etchings or lithographs. Some specialize in them. Some do them only occasionally. But there is a tremendous difference in price between a print and a painting. Everybody recognizes Frank Stella as a major force in contemporary art and his paintings sell for around \$25,000 but you can buy one of his prints for \$250, although some go as high as \$1,500. And the prices of older prints are going up. In the early sixties you could buy a Jasper Johns lithograph for \$75; now they're as high as \$7,500. This is quite a different situation from the early years of the century when no one cared very much about prints. Picasso and Cézanne, for instance, both made graphics, but except for a handful of each edition, they disappeared. Now they are beginning to turn up again. I spent five years looking for one from Picasso's "Saltimbanque Suite," but couldn't find it at any major print dealer's in the world. One finally came up for auction and sold for a very high price, then suddenly, within six months, ten appeared on the market.

What about multiples?

Multiples, whether they are made of plastic, enamel, metal, or whatever, are three-dimensional and often machine-made. Some are very inexpensive. I understand last spring's show of multiples at the Philadelphia Museum included examples

Continued on page 154

Your meals change every day. So should your dishwasher.

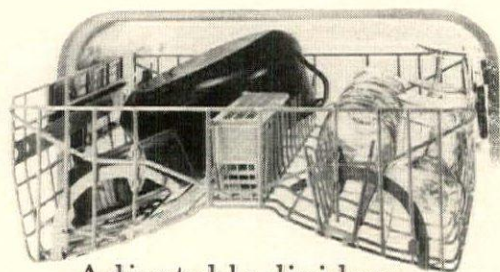

Adjustable dividers in the top rack hold glasses in place, fold flat for larger items.

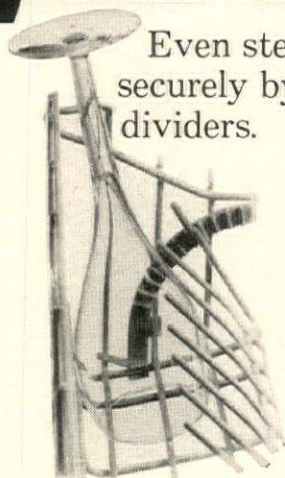

Even stemware is held securely by the adjustable dividers.

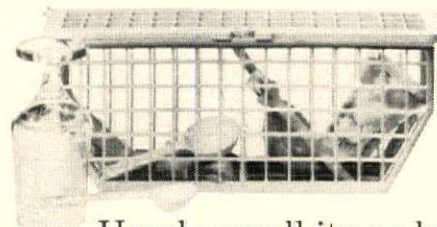

Handy small-items basket holds such things as measuring spoons, corn cob holders and pickle forks.

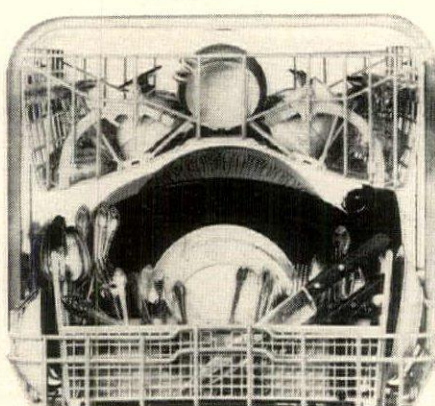

The top rack adjusts to 9 different positions. Lower it. Raise it. Or tilt it to make room for big things in both racks.

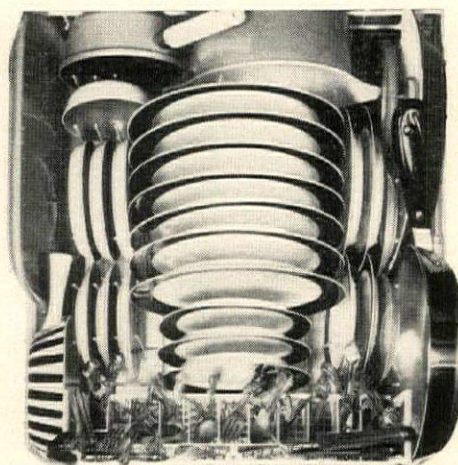
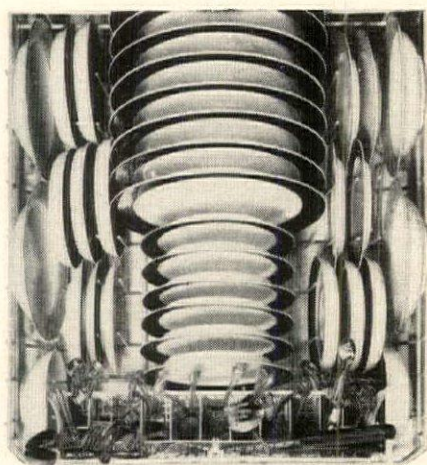

Line up a tableful of plates in the lower rack. Or fold down the dividers in the back for an extra casserole. Pans fit easily along the sides.

This new KitchenAid Superba dishwasher adjusts to your eating habits. It's the closest thing yet to a custom made dishwasher. See it at your KitchenAid

dealer. He's in the Yellow Pages. Or write to KitchenAid Dishwashers, Dept. 1DA-10, The Hobart Manufacturing Company, Troy, Ohio 45373.



KitchenAid
Dishwashers and Disposers
Hot-water Dispensers

King Congo is here.

He's sweeping the country! King Congo—and his collection of carpets by Congoleum—the experts in covering floors. Bold, splashy prints built to take it in high traffic areas. Deeper, bouncier shags, in decorator multi-color. Plushes that look like pure velvet. Formal sculpture—and more. King Congo got the answer for any floor in the house. And he's waiting for you—at your local "Carpets by Congoleum" dealer.



Carpets by

Congoleum

Seven great ways to bring the outdoors in

The outdoors is what makes the indoors so great. And bringing the outdoors in is where glass comes in. Glass opens up your rooms. Lets the sunshine in. Keeps the weather out. Rooms become part of the total landscape.

Today's new glass gives you all this. Plus beauty, safety, weather-beating insulation and reduced fuel bills.

Here are just a few ideas for decorating and living now with glass. Look at how the great outdoors steps right in to make the indoors scene the greatest.

Why not look into glass for your new home or remodeling plans.

PPG: a Concern for the Future

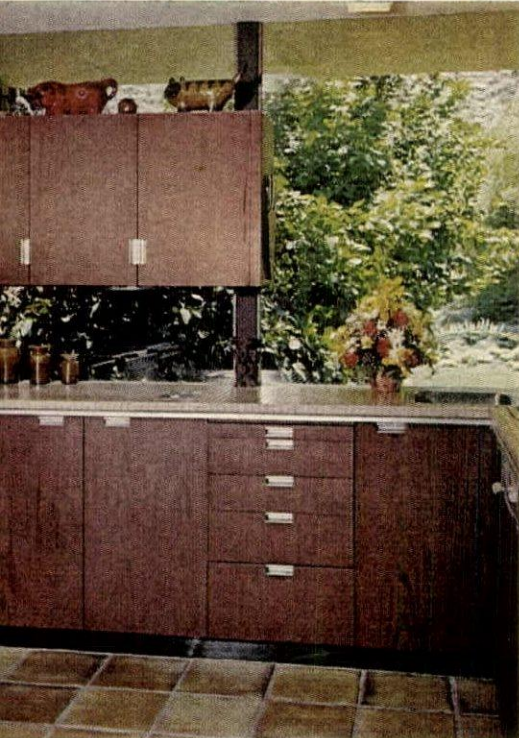

Wm. F. Cody & Assoc., Architects

1 This kitchen has a sunny disposition because the cabinets are positioned to hang in front of the sunlit glass wall. Beautiful idea, and in cold climates PPG *Twindow*[®] insulating glass makes it even more practical.

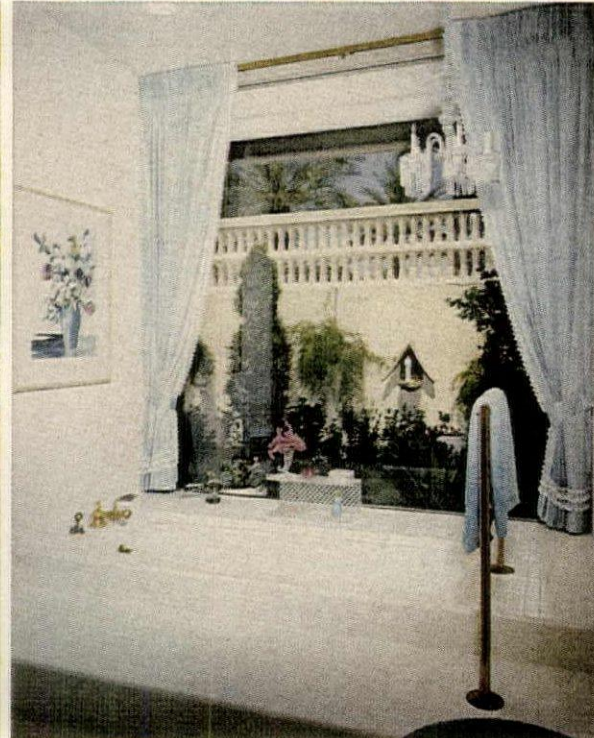

Wm. F. Cody & Assoc., Architects

2 The garden bath, which uses a picture window overlooking a private court, lets you bathe in Roman splendor, but in privacy. And in an area like this, PPG *Herculite*[®] K safety glass lets you move about in safety.



Donald L. Bren, Builder

3 Mirrored wardrobe doors introduce glamor, a feeling of spaciousness, more light and beautiful practicality to the master bedroom. And to give the finest reflection to this idea, use PPG *High-Fidelity*[®] mirrors.

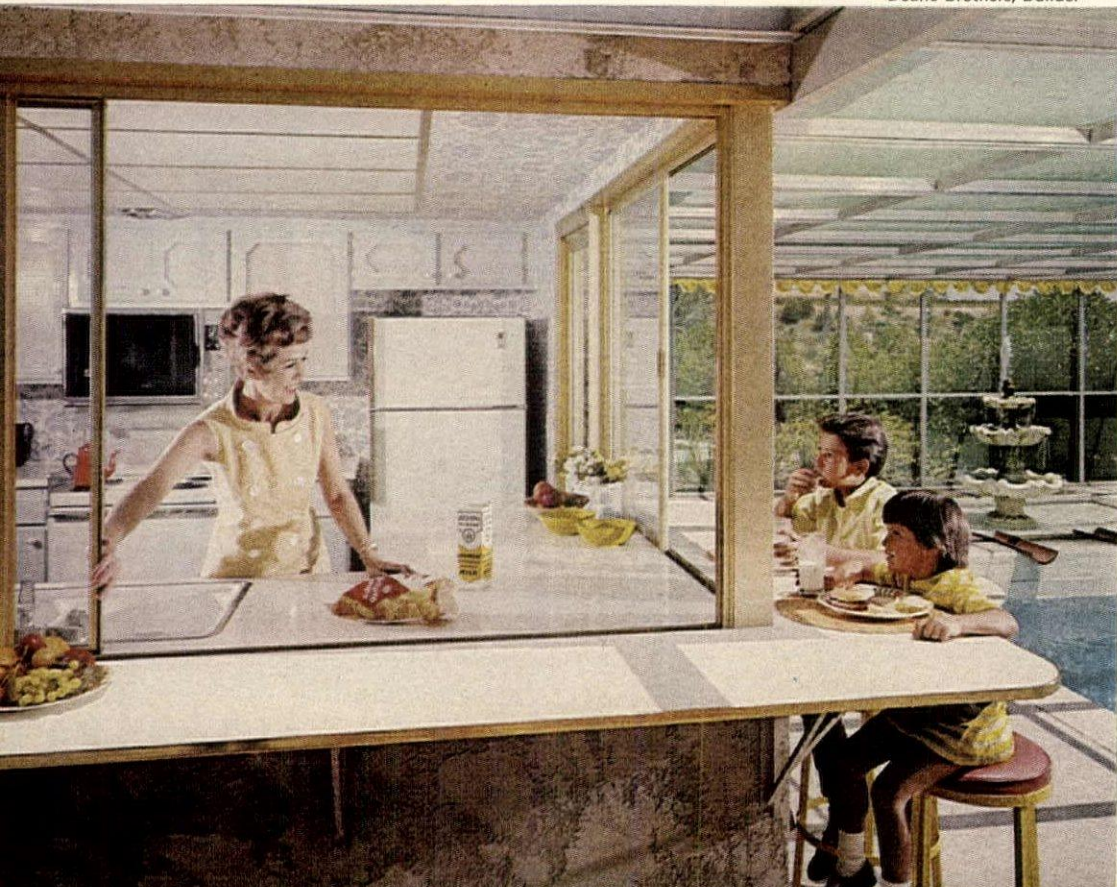

Deane Brothers, Builder

4 Now the outlook for kitchens can be exciting, as well as practical. Sliding glass windows with a wrap-around, pass-through serving counter make this kitchen and the great outdoors one big happy unit.



outdoors indoors with PPG glass.

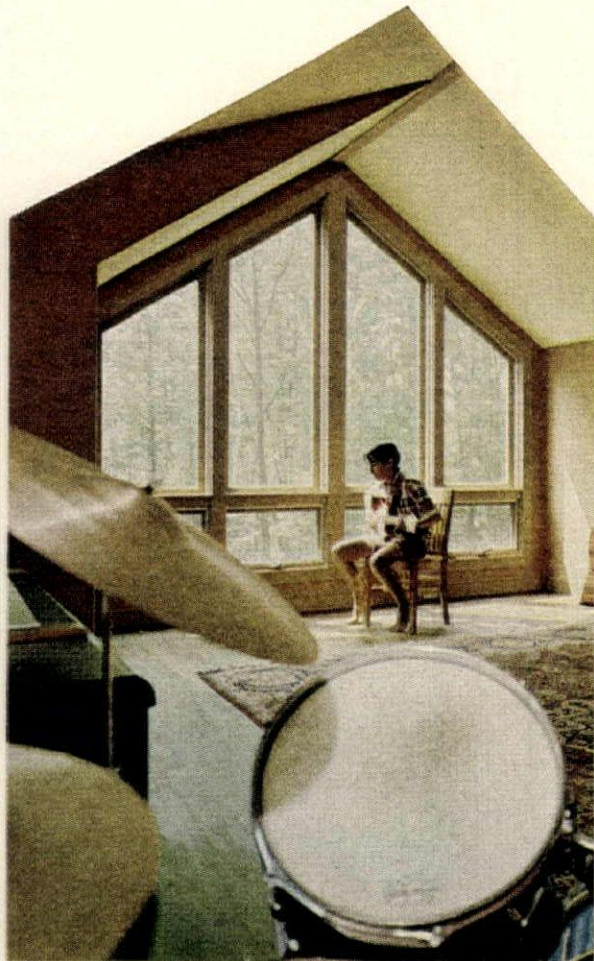
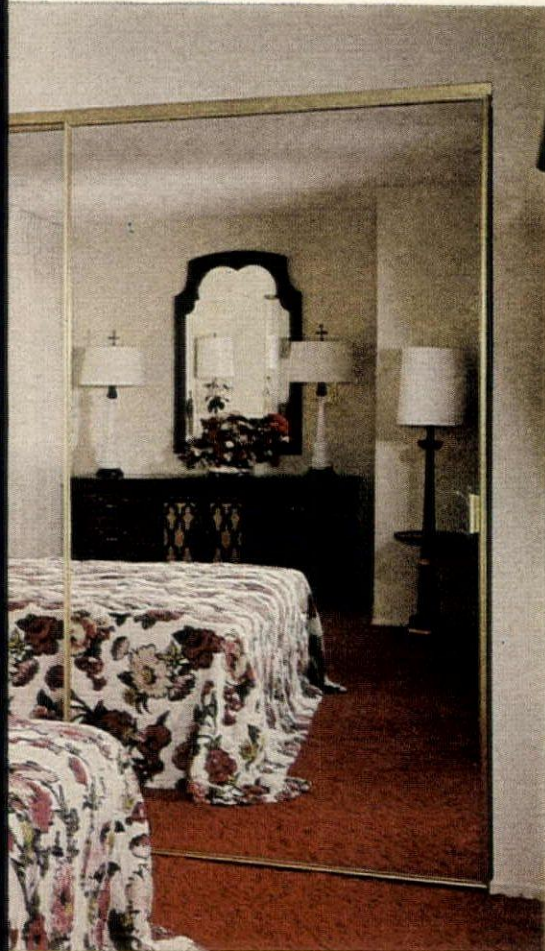

Charles B. Wills & Co., Builder

5 Who says attics are dull, dark and dismal places. Gable end windows in this colonial create a cheerful upstairs rumpus room.



Robert Andrews, Builder

6 A two-story fixed-glass window wall overlooking a private court gives this dining area light, excitement and a real outdoors flavor.

Richard Chalfant, Architect



7 Here's leisure living in the up-dated sun porch. PPG *Herculite K* safety glass in glass walls and sliding glass doors makes an idea like this possible, practical and safe.

If you'd like hundreds of other beautiful, innovative ideas with glass, send the coupon with 25¢. We'll send you PPG's "Open House/USA." Fifty-six pages of building, remodeling and decorating ideas in full color. PPG Industries, Inc., One Gateway Center, Pittsburgh, Pa. 15222.

PPG Industries, Open House
One Gateway Center, Dept. HG-1-4
Pittsburgh, Pa. 15222

Gentlemen:
Enclosed is 25¢ for handling. Send me a copy of PPG's "Open House/USA" at the following address:

Name _____

Address _____

City _____ State _____ Zip _____

This mattress is rated **X**

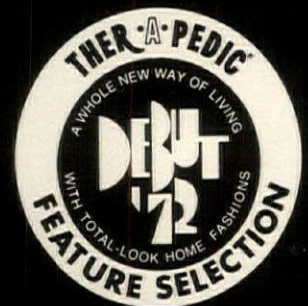

- X** This mattress is rated "X" for extra value . . . extra, patented features at no extra cost to you. It's the mature mattress restricted to mature people.
- X** Enjoy extra support and extra years of comfort with Triple Edge extra value . . . Therapedic's patented no-sag mattress border. No more annoying sag, sway or roll.
- X** Can you handle the x-rated mattress? You can, with Perma-Grip . . . Therapedic's patented no-rip handle. First handle you can really use. To make up your bed easier, turn it in a breeze.

See the X-Rated Mattress: Follow the Crowd to Your Registered Therapedic Dealer.
 Mfrs. Suggested Retail Price \$89.95, mattress or foundation



first and only major
 bedding manufacturer
 to earn the
FURNITURE U.S.A.
DESIGN AWARD

THER·A·PEDIC[®]
Medi-Coil with **TRIPLE·EDGE[®]**

Therapedic Associates, Inc., Garwood, N. J.



For elegant traditional living . . . Con-Tact brand flocked 'Empress' and provincial 'Wormy Chestnut'.

Con-Tact®
it's a
living
thing.

Same room—so many ways to decorate it.

A little here, a whole lot there and tradition comes alive — the incredibly easy self-adhesive Con-Tact plastic way.

Or — if your mood is modern, create your own supergraphic atmosphere with Con-Tact polished patent plastic.

Send for the new FREE "Con-Tact How-To" folder which shows 6 easy-to-make graphic designs, including instructions on how to make the graphic picture above the fireplace, plus a full-color guide to 200 Con-Tact patterns. Write to Con-Tact, Dept. G 1407 Broadway, New York, N.Y. 10018.

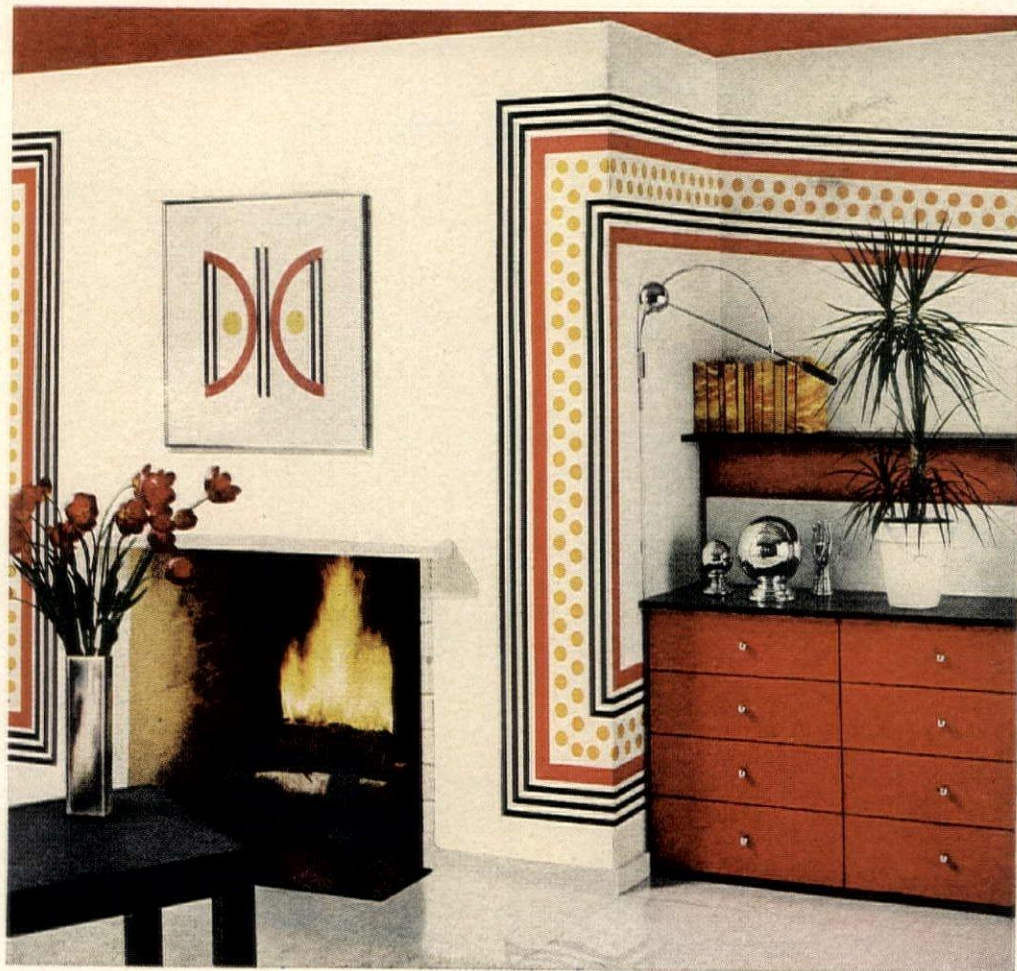

For ultra modern living . . . polished patent Con-Tact brand 'Discotheque' pattern and shiny solids.

Distributed in Canada by Daly & Morin, Montreal, Que.

CON-TACT® IS A REGISTERED TRADEMARK OF COMARK PLASTICS, A CONSUMER PRODUCTS DIVISION OF UNITED MERCHANTS AND MANUFACTURERS, INC.

Con-Tact®
 BRAND
 SELF-ADHESIVE PLASTIC

TOMLINSON

Regency Bamboo and glass—
fresh from the 18th Century.
The Hasi Hester Collection.
For free card of intro-
duction to your Tomlinson
retailer, write to Helen
Gay, Tomlinson Furniture,
High Point, North
Carolina 27261.
Set of design folios \$5.

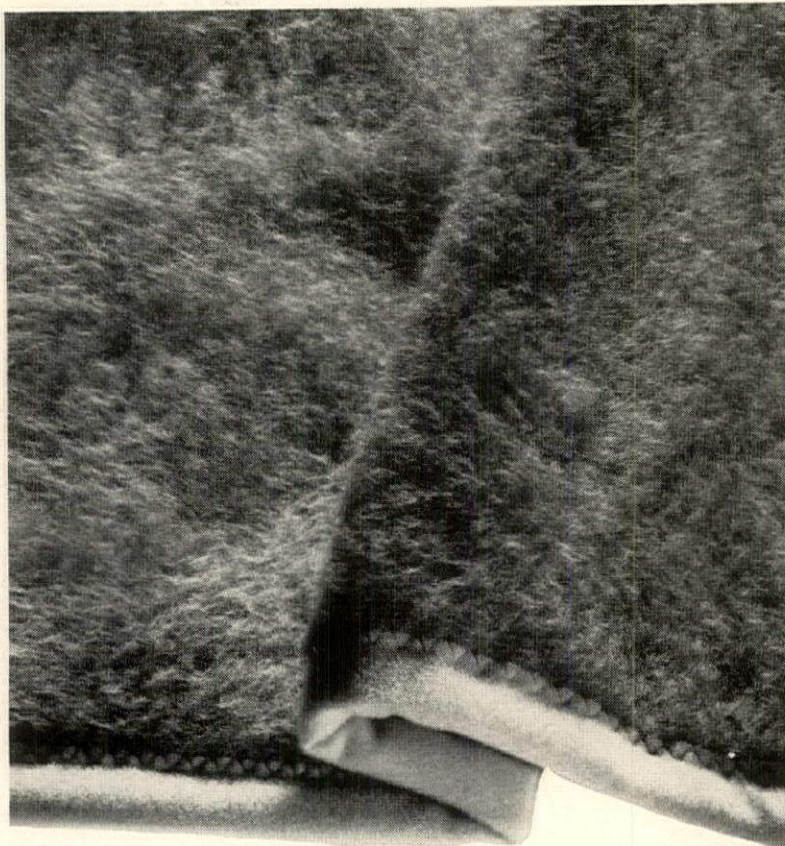
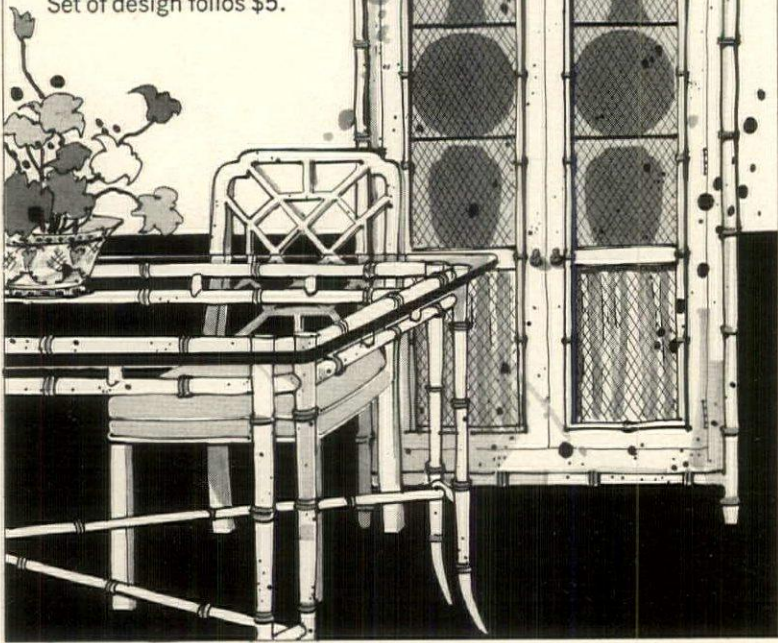

The blanket you have to go to bed with.

"Zephyr"®, an experience in sensuality. A delightful gift. 100% virgin Acrilan® acrylic. Monsanto Wear Dated 3 year guarantee. In 5 sizes from \$19 to \$35 at better department stores.

Another masterpiece from **North Star** by **Chatham**

ELKIN, N.C. 28621

Available at: THE BROADWAY STORES, California

JORDAN MARSH, Boston, Mass.

KRAUSS COMPANY, LTD., New Orleans, La.

The Loveliest rooms I've ever seen

BY CORNELIA CONGER

EDITOR'S NOTE: *We may be quite happy today sitting on the floor. We may be content to sleep, eat, and work in one place as long as it gives us a sense of freedom. We certainly value the independence to be whatever we are and not what someone tells us we ought to be. Yet it's rewarding now and then to look back at houses and rooms designed for an altogether different life style, and few people can take us back as far and as vividly as the much admired Chicago decorator, Cornelia Conger. Her professional career began in 1915 when she opened her own office, which she has run ever since except for three years in the twenties. During that time she managed the antique shop in Chicago owned by Syrie Maugham, the decorator who sparked the first great rage for white. A founding member and now a fellow of the American Institute of Interior Designers, Miss Conger has been first vice-president of the organization's national board and president of its Illinois chapter. But "the four loveliest rooms I have ever seen" she visited not as a professional designer but as a young guest. Although she has shared these reminiscences with audiences in several cities about the U. S., this is the first time she has described them in print.*

SUMMER ENCHANTMENT IN A ROCOCO PALACE

Many years ago—in 1911 to be exact—my mother and I spent several months in Venice. She made friends easily and effortlessly with many of the attractive Venetians, among them the famous beauty of the nineties, Contessa Morosini, the daughter of a successful banker who had married into one of the great ducal families. But she had divorced her husband and, with her daughter, had gone to live in the Palazzo di Mula where twice a week she "received" in the evening, keeping open house. After nine, her friends drifted in and gathered in her salon on the *mezzanino*—a long low intimate room in marked contrast to the lofty and stately apartments on the *piano nobile*, where she held her renowned birthday ball and where most of the crowned heads, great artists, and distinguished people of the time had been entertained. This more informal room where we met so often was one of the most entrancing I have ever seen. The walls were what my mother called the "cookie-cutter" style of architecture—panels surrounded by fanciful arabesques cut out of the plaster and sunken only a fraction of an inch, the surface painted in a hard shiny ivory, the recessed stiles in a dull finish of the same tint. In these panels were set four large decorative paintings of the romantic Hubert Robert type of ruins and water. Between them hung lovely dim mirrors in narrow baroque gilt frames. Very full curtains of eighteenth-century Venetian damask, in that wonderful yellow no other city ever surpassed, hung at windows that ran across the

Continued on page 44

HOUSE & GARDEN

The "in" career that lets you be "way out"

As an interior decorator, you can turn your imagination loose...and get paid handsomely for it!

If you like to express yourself—if you take pleasure in being creative—why don't you become a professional interior decorator and really let yourself go? With a little spare time training—in your own home—you'll be amazed at how you can develop your talent.

Trained newcomers are welcome in this field. Many begin their careers in smart department stores, elegant decorating studios and charming specialty shops.

There are plenty of opportunities for starting your own business, too. You can use your talents in decorating homes, offices, clubs and institutions. Designing and furnishing even a single room may earn a decorator hundreds of dollars—larger assignments much more. Every day is like a shopping spree—with other people's money!

Being a decorator lets you shape your own life. Your career can be full-time or part-time, with hours practically of your own choosing. You are always doing something new, meeting interesting people, working in a world of fashion.

Learn in your spare hours

The LaSalle Course in Interior Decorating gives you complete up-to-date instruction at home. Lessons come to you by mail; they are as fascinating as the professional work itself. A remarkable set of visual aids is included in the course; a simple-to-operate slide projector and a complete set of color slides that let you see interiors almost as big as life on your wall. You also get professional sketching equipment, coloring materials,

stencils that make it easy for you to draw room plans, and much more.

Step by step, you are shown how to make the most of your creative ability. You are taught the principles of color and design, trained in the selection and use of furniture, fabrics, accessories, lighting—and adapting them to the newest patterns of living. You learn the tricks of blending traditional and contemporary styles that sets the keynote of today's best decoration.

You receive individual attention throughout your training. Even before you have finished the course, you can apply your new skills to beautifying your own home.

More than 2,000,000 people have enrolled in LaSalle's home-study programs. If you are seriously interested in an exciting decorating career, mail the coupon for your free booklet "Your Career in Interior Decoration." You may be surprised at the low cost of the course. LaSalle, 417 S. Dearborn Street, Chicago, Illinois 60605.



LA SALLE EXTENSION UNIVERSITY

A Correspondence Institution

417 S. Dearborn Street, Dept. 70-021, Chicago, Illinois 60605

Please mail me your illustrated booklet "Your Career in Interior Decoration," describing the LaSalle home study course.

Mr. _____ Age _____
Mrs. _____
Miss _____ (Circle title and please print)

Address _____ Apt. No. _____

City _____

State _____ Zip _____

116

Photographed at The Hartman Galleries, N.Y.C.

© 1971 LaSalle Extension University

**Before
you lay out
the money
for carpeting,
you owe it
to yourself
to read this:**

Wool is the fiber with bounce and buoyancy built in for life.

Inside of each wool fiber is an uncopyable coiled spring structure that gives wool its lasting resiliency and strength. The wool fiber can be stretched 30% of its length or crumpled into a tight ball and still return to

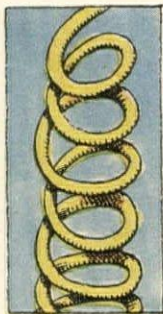

its original dimensions without damage.

It can be flexed and twisted thousands of times without breaking. That's why you've heard of wool carpets lasting beautifully for hundreds of years.

If man-made fibers could copy the structure of wool they wouldn't be man-made. They would be wool.

Wool cleans easily because it's the only fiber with a natural protective covering.

Wool stays cleaner longer and cleans beautifully when it needs it because the uncopyable inner structure of the wool fiber is protected by an uncopyable outer covering.

If you look at the surface of a strand of wool under a powerful microscope you will see that it has a covering of thin scale-like cells that overlap each other like the shingles on a roof. Just as a shingled roof protects your house, the shingled layer protects the heart of wool.

And that isn't all. There's still another protective layer on top of that... that's why wool carpets have a natural resistance to spills and dirt and why they resist the build-up of static electricity which attracts dirt.

These are all part of the reason why wool cleans easily whether in small areas or wall-to-wall.



Wool is now well within your price range.

Now you can have all the beauty and benefits of wool for far less than you'd expect.

Now because of new and improved ways of processing wool, you can choose from a whole world of styles and textures for less than \$10.00 a square yard. From the biggest names in carpeting.

But even if you choose a higher priced wool carpeting it's still a better value than other carpet fibers. Less expensive fibers are more expensive in the long run.



Wool is the only fiber with a natural affinity for color.

Because the wool fiber is protein, it soaks up dyes completely, permanently and beautifully. The reason wool holds color so well is because the color actually becomes part of the fiber. That's why wool carpeting gives you the choice of the richest colors possible.

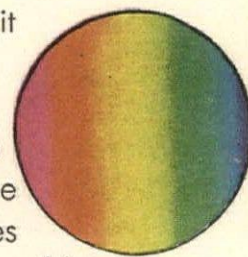

And wool's unique, uncopyable natural structure is what makes it look and act and feel incredibly luxurious for years no matter what the style and texture—from plush velvets to wild uninhibited shags.

Wool is the carpet fiber that is naturally flame resistant.

Properly constructed wool carpets do not melt or support combustion. That's why safety experts recommend using a wool rug or blanket to smother flames.

Now, when you're covering an area as large as a floor, of course flame resistance is an important consideration.

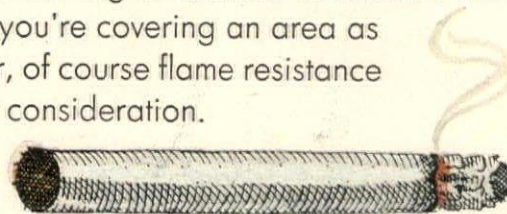

And it's nice to know that a dropped cigarette or lighted match won't leave a permanent ugly black mark as it usually does on synthetic carpeting. With wool, the charred fibers can easily be brushed away leaving little or no change in appearance.

Wool is the only fiber with this mark of quality.

The Woolmark label on carpeting means it has passed a battery of tests in the Wool Bureau laboratories, for fiber content, pile weight per square yard, mothproofing, backing construction.

So look for the Woolmark label. It means you've got a quality-tested carpet made of pure wool pile.



Wool. It's got life.

The Wool Bureau, Inc., Carpet Division
360 Lexington Avenue, New York, N.Y. 10017

HG-2

Before I lay out the money for carpeting, send me a **FREE CARPET BUYING GUIDE** that compares the features and performance of all the leading carpet fibers.

Name _____

Address _____

City _____ State _____ Zip _____

entire front of the room from floor to ceiling. The folds were looped back to let in the gentle summer breeze and spilled voluptuously onto the dark polished terrazzo floor. Masses of flowering plants—all white—were banked high in the corners. Beneath each of the four pictures stood an old gilt sofa covered in faded brocade with fauteuils and bergères charmingly and invitingly grouped around it. Three or four bridge tables were always set up, perfectly equipped. Chandeliers of soft-toned Venetian glass hung like bouquets from the ceiling, which was cut into the same designs as the walls. Sitting around the room were women in pale chiffons, naval officers in crisp white. Usually one couple was leaning on the yellow brocade cushions that lay on the top of the stone balustrade at the window—leaning on them to look down on the canal and catch the songs from the music boats farther along toward the piazza.

We usually played late and when we were ready to leave found our patient gondoliers curled up asleep in their boats near the water-doors—the boats tied to posts painted blue with the Morosini coat of arms atop each one.

Slipping silently along the canal on our way home, we could see the first hint of dawn coming up and feel the still night air freshened by the cool early morning breeze from the Adriatic. For me today, it all has a dream-like quality of a vanished world—charming, frivolous perhaps, but highly civilized and full of grace.

ROSE MARBLE AND THE OPÉRA COMIQUE

In those days one of the greatest connoisseurs of eighteenth-

century decoration was Count Boni de Castellane. His great ambition was to build the most beautiful house in Paris, to devote his life to the perfection of each detail. He had heard of a design for a great staircase that was to have been built at Versailles just before the French Revolution—and of a quarry of exquisite pale rose marble owned by the French government from which to execute this work. The legend was that the debonair Boni was willing to marry any woman who would enable him to make this dream come true and—rather unfortunately for her—he persuaded the gentle American, Anna Gould, later the Duchess of Talleyrand, to be his wife.

You probably recall the house, about halfway up the Avenue du Bois de Boulogne on the right—not very impressive as you pass since the ground is terraced up and only one story shows along the avenue, its façade in the style of the Grand Trianon. But around the corner is a great court and there two full stories are revealed. My mother and I dined there one night shortly before World War I. As we entered, the great marble staircase rose before us. We went up a few steps to a broad landing and through an archway leading to the library where the guests assembled. At the time of the Castellanes' divorce the house had not been finished—the banquet room was never built—so dinner was served beside the white marble swimming pool. The table was unforgettably lovely, covered with thousands of bits of delicate old lace sewn together. Down the center were many urns of white soft paste Sèvres full of pink rambling roses and interspersed with countless ormolu candelabra. At each place was an individual gilt soup tureen, Louis XV, its cover surmounted by a tiny rosebud.

Continued on page 140

A.M. P.M.

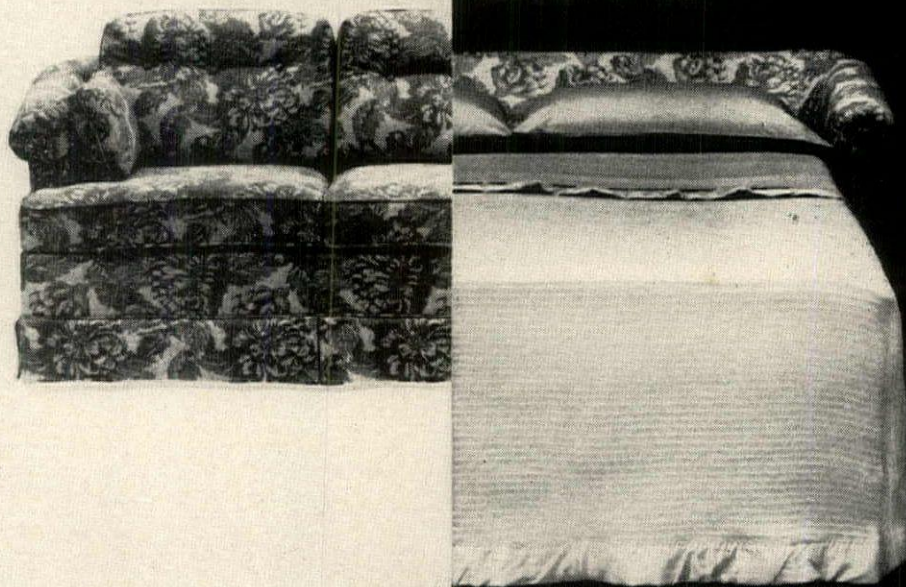

The sofa that handles both day and night
with the same beauty and comfort.

**The Sometime Sofa[®]
by Jamison**

Since 1883

©Jamison Bedding, Inc., P. O. Box 989, Nashville, Tennessee 37202

Fabrics protected by
DUPONT
ZEPHEL[®]
STAIN REPELLER

21 great features in one Tappan gas range.

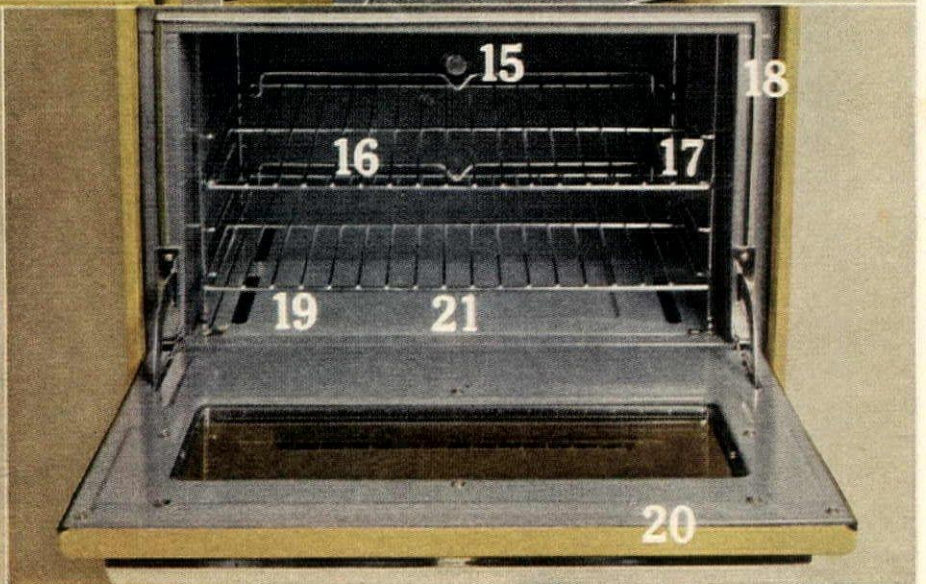
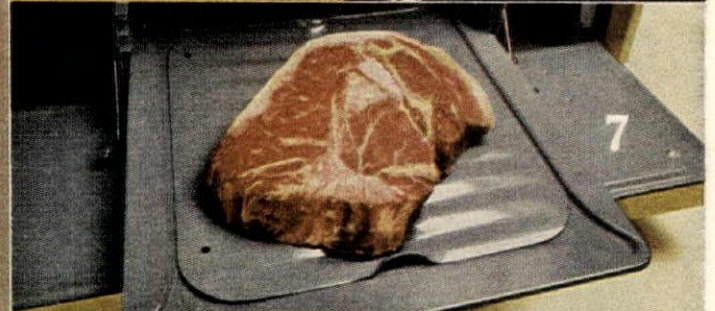
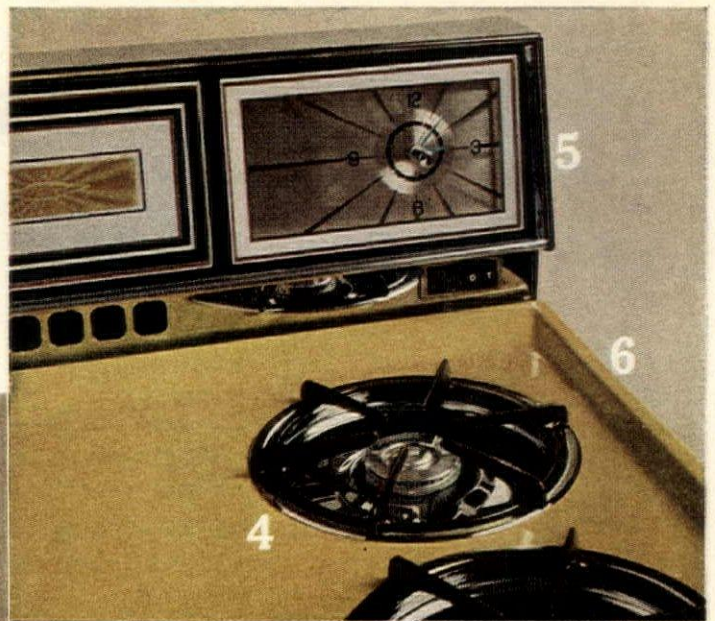
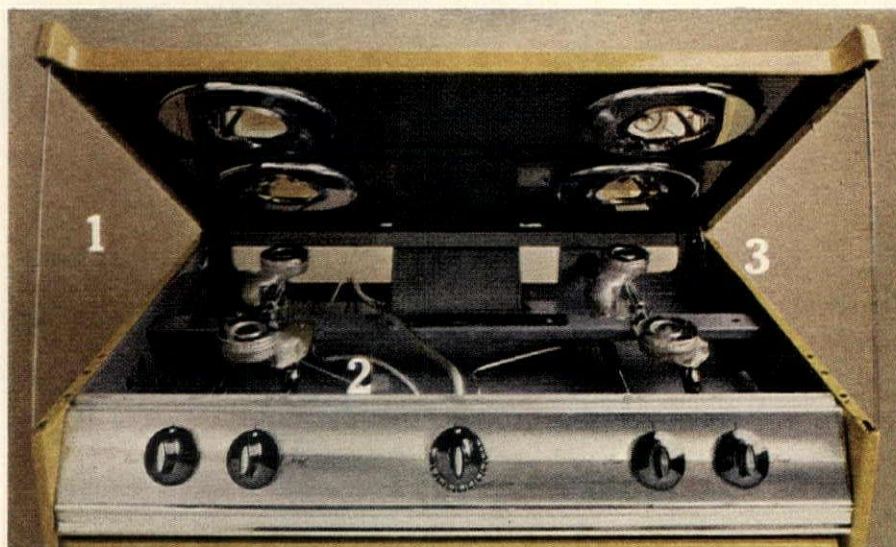

\$199⁹⁵

\$199.95. For gas model Z30-1139, shown. Also available in 36-inch model at a slightly higher price. Prices subject to variation in different sections of the country.

Here's the quick, responsive cooking that only gas gives you. Plus 21 Tappan features that will make your life easier.

1. Lift 'n Lock top for easy cleaning.
2. Pressure regulator assures even, steady gas flame.
3. Vitamin Saver Gas Burners for better cooking.
4. Chrome spillover bowls. Easy to clean!
5. Clock with a 4-hour timer.
6. Recessed cooktop catches spills.

7. Roll-out smokeless gas broiler.
8. Illuminated back panel—lights cooking surface.
9. Low keep-warm oven setting. Thaws frozen foods, too.
10. Big oven window, switch-on light.
11. Full side panels keep heat in.
12. Airwash insulation keeps your kitchen cooler.
13. Colors—Harvest gold, avocado, coppertone, white.

14. Tappan Certified Nationwide Service.
15. Super-size gas oven cooks big meals all at once.
16. Two sturdy chrome oven racks.
17. Removable 4-position rack glides.
18. Removable oven seals make cleaning easier.
19. Porcelain oven bottom—it's removable.
20. Oven door lifts off to help you clean.
21. Automatic gas pilots on burners, broiler and oven.

TAPPAN GAS

Tappan Feature Fair now going on at participating dealers.

AMERICAN GAS ASSOCIATION, INC.



ARE YOU BUYING *Take It!*

in recent years a scientific literature has accumulated testifying to the undoubted cosmetic value of many natural substances when applied externally to the skin—notably fruit and vegetable juices.

Unfortunately, this information has set the groundwork for the ubiquitous operators of the fast buck. A miasma of "natural" preparations have appeared which, to put it bluntly, are complete frauds. Cucumber preparations made with "cucumbers" that never grew—creams and lotions with "peaches" that never saw the inside of a can—"strawberry" soaps, oils, facials, emulsions, masks, and what have you—all strictly out of the chemist's beaker, etc. etc. ad nauseam, with every "natural" ingredient one can conjure up.

As so many of our patrons know, we have for many decades featured a group of Cucumber cosmetics actually containing the genuine article. Now, to bring a further sense of responsibility into this area of fantasy-quackery, we are introducing three bona fide, natural moisture creams. These, we guarantee, are absolutely the real thing. They are designated under the copyrighted name of CERTI-NATURAL® as evidence that our pharmacists have incorporated into these creams the actual, pure substance indicated—derived from its natural source—in a definite proportion—as certified on the label.

CERTI-NATURAL® CREAMS
4 ounce \$5.00 16 ounce \$15.00

PEACH in a super-rich, whipped cream base for *dry skin*

BANANA in a bland, easily absorbable base for *normal skin*

STRAWBERRY in a delicate, emollient base for *oily skin*

As one of the originators of genuine, natural beauty aids—our testimonials hark back to Sarah Bernhardt, Lillian Russell, Adelina Patti and beyond—we are proud to present these unequivocal, truly natural creams.

CASWELL-MASSEY CO. LTD. ★ EST. 1752		
CERTI-NATURAL® MOISTURE CREAMS		
(Check Skin type, size & quantity required)		
SKIN TYPE	SIZES	QTY.
Dry _____	4oz. @ \$5 16oz. @ \$15	_____
Normal _____	_____	_____
Oily _____	_____	_____
Name: _____		
Address: _____		
City: _____		
State: _____ Zip: _____		
CHEMISTS & PERFUMERS ★ 320 W. 13th ST.		

All major charge cards accepted. Kindly include charge number. Visit our historic pharmacy at 518 Lexington Ave. (48th St.) or send \$1.00 for two issues of our unique catalog. Sorry, no C.O.D.

SOME NOTES ON GOOD LOOKS & GOOD HEALTH

BY REBECCA WARFIELD

BOTULISM PUSHES THE PANIC BUTTON

Suddenly last summer one of the classic features of the great American Dream—the American Woman's daily exercise-stroll down the supermarket aisle—suffered a Loss of Innocence. American women—reaching out for a can of soup—felt that they had become Big Gamblers overnight. Was it or wasn't it safe? The fact that the odds are overwhelmingly on the side of safety is not quite the same as that old dead-certainty.

The circumstances. Botulism, a rare, peculiar, perverse, and deadly disease, had struck without warning. On the evening of June 29, a Westchester couple sat down to a supper of bowls of cold vichyssoise that had come from a can of soup, produced by a well-known small firm who—it later turned out—also put out many products under other, also posh labels. The next day this man, a prominent New York banker was dead and his wife gravely ill. The cause was attributed to botulism present in the vichyssoise and untold thousands started living with a private panic.

Most doctors who knew of botulism had never seen a case and most Americans had never heard of it. Those familiar with the word felt certain that everything was under control. For instance, this lulling paragraph appears in a journal currently in use in the medical department of a large New York firm—"In the United States most of the outbreaks [of botulism] now follow the eating of home-preserved vegetables or fruits served cold in a salad. Years ago, commercially canned foods were often at fault, but after intensive research, D. K. Meyer and his associates showed the packers how they could always be sure of destroying the highly heat-resistant spores that were causing all the trouble. Since then it has been the home-preserved foods that caused the outbreaks of botulism."

The cause of death. What went wrong this summer? Human nature, presumably. The situation is still unclear but it is understood that the proper procedures were in effect at the plant. What seems to have happened is that an operator, wanting to leave early, turned off the heat for a vat of soup a few minutes before it would have reached the effective conditions for destroying botulism. An instant alarm went out for the tainted batch and five cans were found to be contaminated. On the seventh of June, the Food and Drug Administration along with the Agriculture Department ordered a recall of all the soups, sauces, and other canned foods made by the company, as well as all food put out by them under other labels. That is reassuring. What is so unnerving is the very life style of the bacillus that seems to tear up and throw away the max-

Continued on page 48



The \$520 Beautyrest. It supports you in a style to which you're not accustomed.

All the pampering and creams in the world can't do as much for your looks as a good night's rest.

The kind you get on the most luxurious mattress ever. The King size Beautyrest® Exquisite.

It has a light, fluffy, quilted thing, something like a comforter, sewn right onto the top.

And, if that doesn't make you feel as if you're lying on a bed of roses, the Pauline Trigere-styled damask rose fabric cover will. So will the Beautyrest

coils inside. Each coil is built into its own separate pocket. So each one is free to separately support whichever part of your body it happens to be under.

By conforming to your shape, a Beautyrest gives you more support than any other firm mattress.

The price of the Exquisite includes our new, scientifically designed Full-Support Beautyrest

Foundation. A Queen size set costs \$399.95. Twin or double sets cost \$279.95.

The Beautyrest Exquisite. It may be a luxury. But the good night's rest it gives you is a necessity.

For your nearest Beautyrest dealer, call this free number: 800-243-6000. (In Connecticut, call 1-800-942-0655.)



Beautyrest by Simmons

gives every part of your body a good night's rest.

Douching vs. Norforms

(Once you make the comparison, there's no comparison.)

9:04

You decide to douche to stop embarrassing feminine odor.

9:04

You decide to use Norforms[®], *The Internal Deodorant*.™

9:05

You collect all that douching equipment from its hiding place. (Remember, later you'll have to hide it all over again.)

9:05

You insert one tiny Norforms. (Wasn't that much easier than douching?) And Norforms are the germicidal suppositories that stop odor in a way no douche can.

9:06

You begin mixing and measuring. (Oops—you just spilled some.)

9:06

Doctor-tested Norforms kill germs, stop odor where it starts—internally. So safe to insert, you can use them as often as needed. And remember, with Norforms—no mess, no fuss, no equipment.

9:10

You begin douching.

9:10

You know you'll feel clean, fresh, odor-free for hours with Norforms.

9:15

You're still douching.

9:20

You're still douching.

9:25

You're still douching...

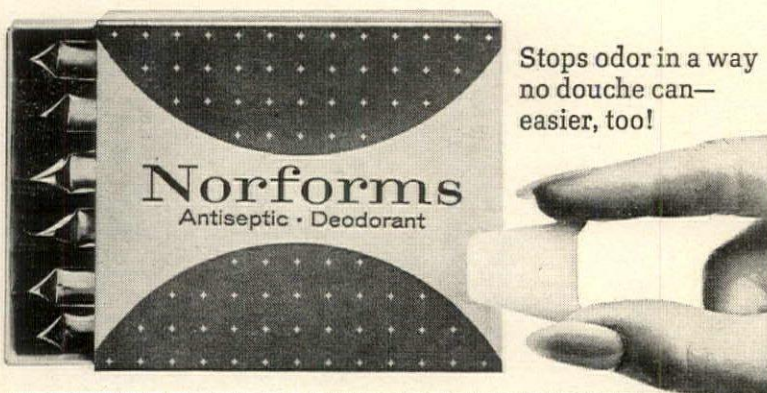

For women only! Free new 12-page booklet, "Answers to Questions Women Ask Most Often." Send this coupon to: The Norwich Pharmacal Company, Dept. HG-10, Norwich, New York 13815.

Name _____

Street _____

City _____

State _____ Zip _____

Don't forget your zip code.

GOOD LOOKS AND GOOD HEALTH

continued from page 46

ims that most Americans of this century were brought up to hang onto—"One, keep everything spotlessly clean; two, rush everything edible instantly into the refrigerator and no harm will befall you." Now we learn that sloppy housekeeping has nothing to do with the case, and that if we want to kill botulism we should never put it on ice. Instead we should rush it to the stove. What is this peculiar killer, anyway?

The character of botulism. If botulism were not such a virulent poison, it would be a wildly fascinating organism. *Clostridium botulinum* is primeval, far predating the Dinosaur and the Dodo Bird, it was alive and well when the earth was new and anaerobic, (from the Greek for "no air") theoretically. Gradually oxygen came into the atmosphere and the anaerobes settled deep in the earth everywhere on earth. Here they have the uncanny and unpleasant ability to turn into spores, which means that they form tiny walls around themselves becoming far more heat-resistant than ordinary cells. This way, when the food they're lodging in is not sufficiently heated, they are sealed alive inside it. Now danger really starts—the spores become active and produce a poison they never owned when they were on earth. This is that toxin so incredibly potent that one millionth of a gram—a speck invisible to the naked eye—can kill a man. Scientists speculate that two glassfuls, properly administered, would be enough to exterminate the whole human race.

When botulism hits the human race. For all its hideous strength, when recognized and treated, it can and has been conquered. The symptoms of this uncommon bacillus, though sometimes confused with common food poisoning, are basically different, because botulism attacks the center nervous system. The patient first develops double vision and drooping eyelids, feels tired and sometimes dizzy, experiences difficulty in swallowing and speaking and—very idiosyncratic of botulism—a certain ropy quality in the saliva. Death usually comes from respiratory failure or from pneumonia. The prognosis that somehow takes some of the horror away from the awful potential is that if patients live past the ninth day they are likely to recover.

Hand off the button? The first reaction of the normal neurotics is to swear off canned foods forever. Next, to promise themselves that they will boil every can of food they ever come near. But the Movers and Shakers, the pioneers in the field of Public Health are unanimous that this is unnecessary so far. They still maintain their unbroken confidence in the absolute integrity and almost religious devotion to the correct procedures of all the big companies in the country.

Dr. Michael Foster, Director of the Food and Research Department of the University of Wisconsin, is very much into botulism and passionate on the subject of home-canning—still the danger zone. No one, he believes, should attempt this without a home cooker, must follow directions fanatically. But when eating commercially canned foods, he says—be wary, never touch a can that is swollen or one with leaky seams or food that smells bad. Sometimes there are no symptoms. There was the case, detailed in a famous piece by Berton Roueché

Continued on page 151

Nylon has always had natural strength.
Now we've given it natural color.

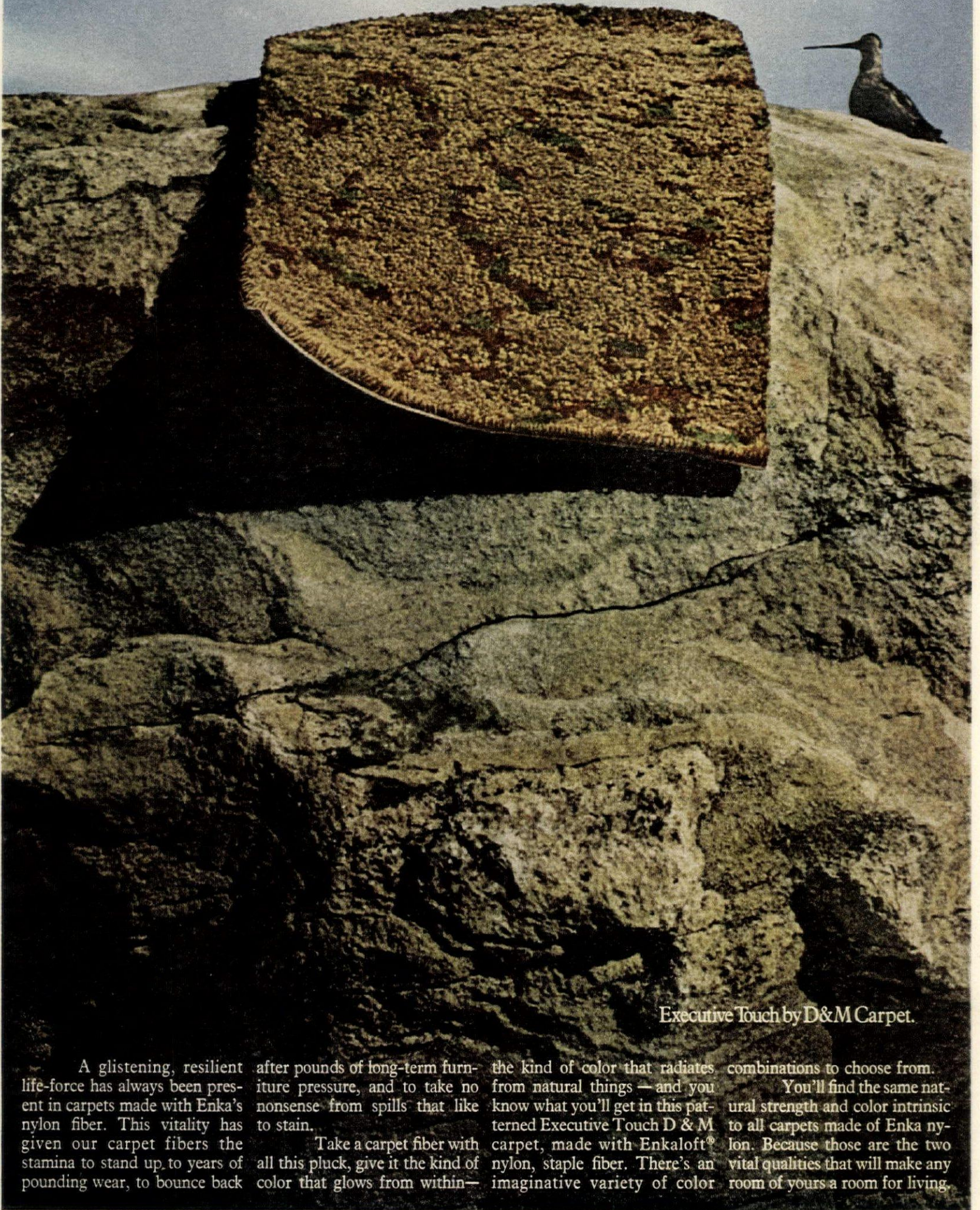

Executive Touch by D&M Carpet.

A glistening, resilient life-force has always been present in carpets made with Enka's nylon fiber. This vitality has given our carpet fibers the stamina to stand up to years of pounding wear, to bounce back

after pounds of long-term furniture pressure, and to take no nonsense from spills that like to stain.

Take a carpet fiber with all this pluck, give it the kind of color that glows from within—

the kind of color that radiates from natural things — and you know what you'll get in this patterned Executive Touch D & M carpet, made with Enkaloft® nylon, staple fiber. There's an imaginative variety of color

combinations to choose from.

You'll find the same natural strength and color intrinsic to all carpets made of Enka nylon. Because those are the two vital qualities that will make any room of yours a room for living.

Enkaloft by **ENKA**. The nylon for natural color.

FOR YOUR NEAREST DISTRIBUTOR, CONTACT D&M CARPETS INC., P.O. BOX 672, CARTERSVILLE, GEORGIA 30120

The most



DUPONT
Soft-Textured
Nylon

- Symbol of Quality
for
- LASTING BEAUTY
 - CLEANABILITY
 - LONG WEAR

in Upholstery Fabrics

comfortable part of your day!

The most comfortable part of your day is whenever you get a chance to sit in your La-Z-Boy®. It's a busy life filled with a million details. And your very own La-Z-Boy® is always there to relax and refresh you. You wanted it because of its unusual comfort as well as its outstanding beauty. Your favorite style actually enhances that favorite room of yours. Wisely, you selected DuPont's irresistible quality of soft-textured nylon, valued for its durability and high performance. And from the kaleidoscope of colors, you picked your favorite shade and fabric. Your La-Z-Boy® Reclina-Rocker® truly provides the most comfortable part of your day!

LA-Z-BOY® RECLINA-ROCKER®

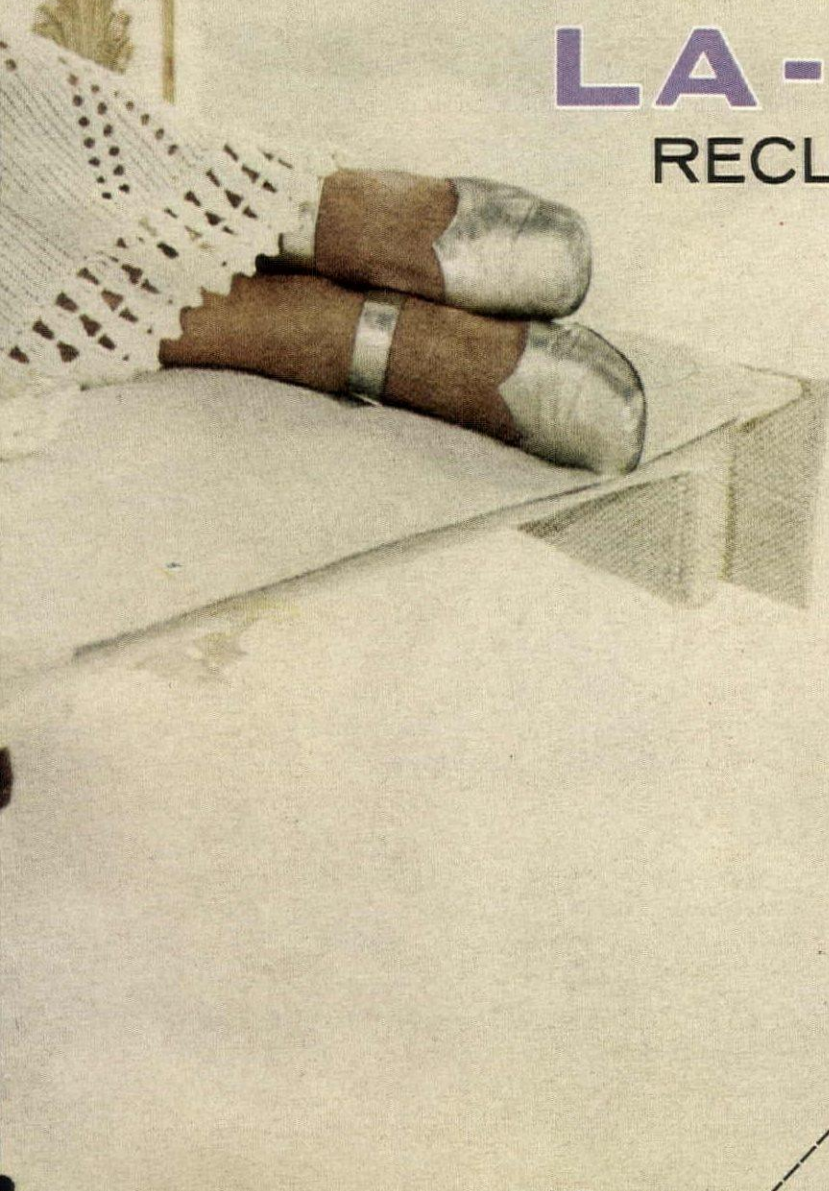

LA-Z-BOY® CHAIR CO., Dept. HG-R71-7, Monroe, Michigan 48161
Please send me FREE Reclina-Rocker® color literature.

NAME

ADDRESS

CITY

STATE

ZIP



help
stamp out
groovy
floors

Insist on Beauti-Glide, the only bed frames guaranteed against damage to floors and carpets. Stop letting the casters on an old-fashioned bed frame make unsightly grooves and gouges under your bed. Get a new Beauti-Glide guaranteed bed frame, complete with modern Rug Rollers or Super Glides! And be sure to check for a Beauti-Glide frame under any new bed you buy. Beauti-Glide bed frames cost as

little as \$14.95. They fit beds of all sizes. And they are the only bed frames guaranteed in writing against damage of any kind to floors and carpets. What's more, Beauti-Glide bed frames make even a king-size bed easier to move when you're cleaning. So read our guarantee, insist on Beauti-Glide bed frames... and help stamp out groovy floors!



Lear Siegler, Inc.
Beauti-Glide Company
Seymour, Indiana 47274

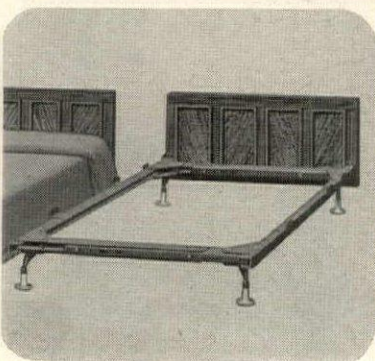
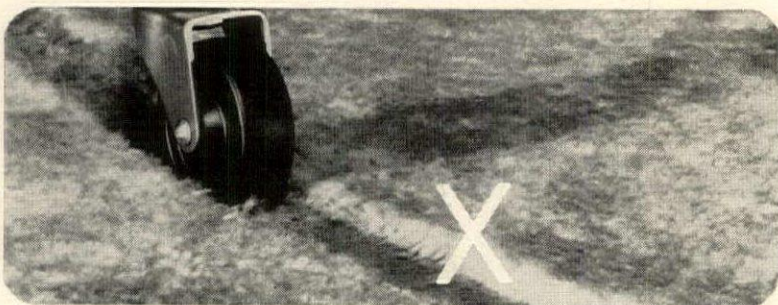

Beauti-Glide®
bed frames, equipped with
Rug Rollers or Super-Glides are

GUARANTEED
for the useful life of the frame, not to
permanently damage carpet or floor sur-
faces of any type. If a carpet or floor
surface is damaged, Beauti-Glide Com-
pany will repair the damaged carpet or
floor surface.

★
Good Housekeeping
GUARANTEES
REPLACEMENT OR REFUND TO CONSUMER

NOTES OF A HAPPY HOUSEKEEPER

BY MARY ELIZABETH FALTER

Now that I've found a fairly *easy way to put on patches*, I'll be able to rescue more of Tommy's worn but beloved jeans. I've always loathed the job because I'm all thumbs when it comes to holding the patch in place, keeping the edges tucked under, and sewing at the same time. So I decided to tackle each of these operations separately. I began by pressing a quarter-inch hem all around the patch with a hot iron. Then I anchored the patch in place with some bits of Scotch tape while I whipstitched the folded edges of the patch and finally the trimmed edge of the original hole. Wouldn't you know that both Tina and Tommy now want me to make colored patches on all their jeans.

Browsing in my favorite kitchen shop the other day I suddenly came upon a dazzling display of shiny, brilliantly colored plastic bowls, plates, cups, and cooking spoons—all looking tempting and practical at the same time. This *gay new plastic kitchenware* comes in orange, red, purple, avocado, and sunflower yellow, all designed to be mixed or matched. Many items are dual purpose: All the mixing bowls turn into salad or serving bowls and trays become platters or relish dishes. There is a good assortment of cooking tools such as slotted spoons and stirring spoons, also a full complement of dishes—plates, cups, mugs. All of it is inexpensive, heat resistant, dishwasher proof. I started our collection with mugs in all the colors, a salad bowl and servers, and an intriguing mixing spoon that looks like an oval loop on a handle and will be just great for whipping up muffin batter and the like. The name of this collection is Gourmet Accessories and it is made by Rainbow Wood Products.

Chalk up a *safe and practical reuse for cleaners' bags*. Sally spent last weekend reorganizing her belongings, and she used the plastic bags to create dust-free storage on her closet shelves. Her retired collection of stuffed animals that she can't part with are now reposing on the top shelf under a see-through tent-like cover made by slitting one bag down the sides. Taped to the back wall and the under side of the shelf, the bag covers the animals completely. As she has more shelf space than drawer space, she arranged a series of open-ended bags along each shelf and put in them all her handbags, sweaters, bathing suits, and shorts. Some of the bags she cut down so that there is just enough of the plastic left at the top to tuck under the pile, making it easy to remove things as they are needed.

After doing heroic duty as a food server at informal parties, my Salton Hotable buffet cart made its debut as a *highly efficient bar*. Instead of setting up the bar on the table in the living room, where it always creates a traffic jam, Tom got the bright idea of temporarily removing the love seat

Continued on page 56

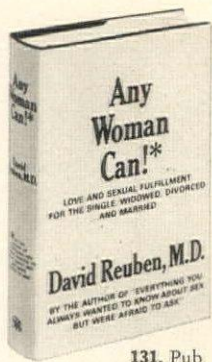

131. Pub price \$7.95

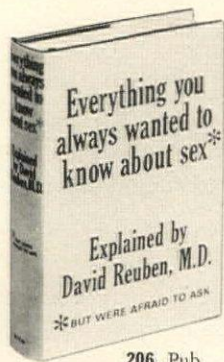

206. Pub price \$6.95

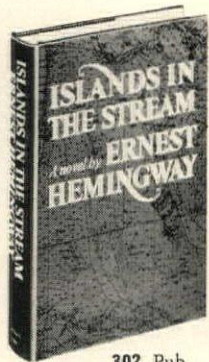

302. Pub price \$10

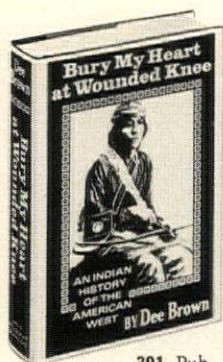

391. Pub price \$10.95

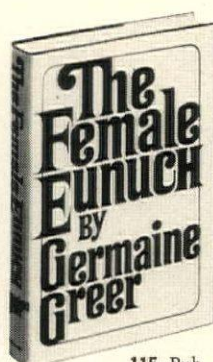

115. Pub price \$6.95

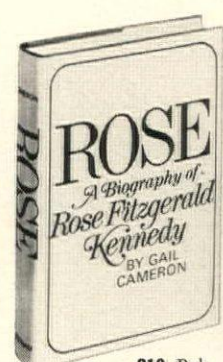

210. Pub price \$6.95

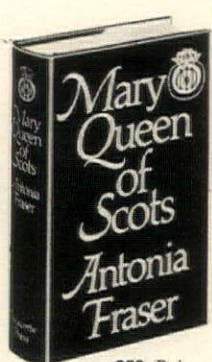

328. Pub price \$10

CATCH UP ON THE BOOKS you have promised yourself to read...

118. THE SAN FRANCISCO EARTHQUAKE by GORDON THOMAS and MAX MORGAN WITTS Photographs (Pub list price \$7.95)

130. THE GRAHAM KERR COOKBOOK by THE GALLOPING GOURMET. Photos (Pub list price \$7.95)

450. THE KEY TO FEMINE RESPONSE IN MARRIAGE by RONALD DEUTSCH. Illustrated (Pub list price \$6.95)

431. THE RISE AND FALL OF THE THIRD REICH by WILLIAM L. SHIRER (Pub list price \$15)

127. THE POETRY OF ROBERT FROST. Edited by EDWARD CONNERY LATHEM (Pub list price \$10.95)

140. THE COMPLETE MEDICAL GUIDE by BENJAMIN F. MILLER, M.D. 3rd Revised edition Illustrated (Pub list price \$9.95)

318. RICH MAN, POOR MAN by IRWIN SHAW (Pub list price \$7.95)

163. MACRAMÉ Creative Design in Knotting by DONA Z. MEILACH Illustrated (Pub list price \$7.95)

161. JOY OF COOKING by ROMBAUER and BECKER Illustrated (Pub list price \$6.95)

184. EMILY POST'S ETIQUETTE. 12th and latest edition. Revised by ELIZABETH L. POST (Pub list price \$6.95)

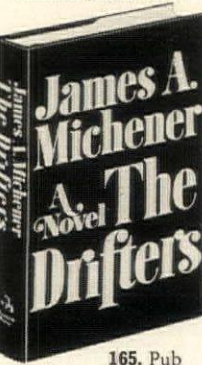

165. Pub price \$10

109. FRANK CAPRA: THE NAME ABOVE THE TITLE by FRANK CAPRA Photographs (Pub list price \$12.50)

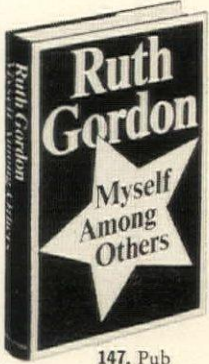

147. Pub price \$10

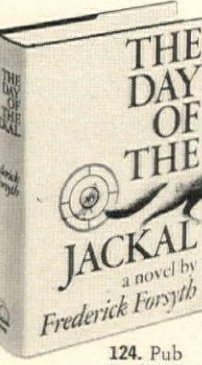

124. Pub price \$7.95

168. THE FAMILY BOOK OF PREVENTIVE MEDICINE by BENJAMIN F. MILLER, M.D., and LAWRENCE GALTON. (Pub list price \$12.95)

117. THE CONDOR PASSES by SHIRLEY ANN GRAU (Pub list price \$7.95)

373. SEX IN HUMAN LOVING by ERIC BERNE, M.D. (Pub list price \$6.95)

531. KHRUSHCHEV REMEMBERS Translated and edited by STROBE TALBOTT Notes by EDWARD CRANKSHAW Photographs (Pub list price \$10)

198. CREWEL EMBROIDERY by ERICA WILSON. Illus. (Pub list price \$7.95)

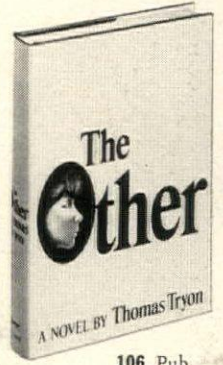

106. Pub price \$6.95

580. MASTERING THE ART OF FRENCH COOKING by CHILD, BERTHOLLE, BECK Illustrated (Pub list price \$12.50)

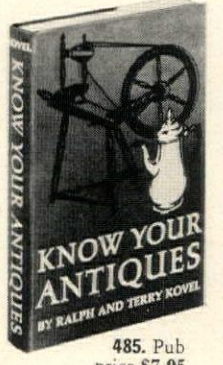

485. Pub price \$7.95

200. HOW CHILDREN LEARN and HOW CHILDREN FAIL by JOHN HOLT. (Pub list prices total \$9.45)

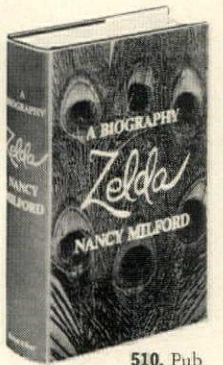

510. Pub price \$10



370. Pub price \$20

256. LOVE IN THE RUINS by WALKER PERCY (Pub list price \$7.95)

351. INSIDE THE THIRD REICH: Memoirs by Albert Speer. Photos (Pub list price \$12.50)

353. THE NEW YORK TIMES COMPLETE MANUAL OF HOME REPAIR by BERNARD GLADSTONE. Illustrated (Pub list price \$7.95)

345. THE EUROPEAN DISCOVERY OF AMERICA The Northern Voyages by SAMUEL ELIOT MORISON. Illustrated (Pub list price \$15)

162. KENT STATE What Happened and Why by JAMES A. MICHENER Photographs (Pub list price \$10)

114. EINSTEIN The Life and Times by RONALD W. CLARK Photographs (Pub list price \$15)

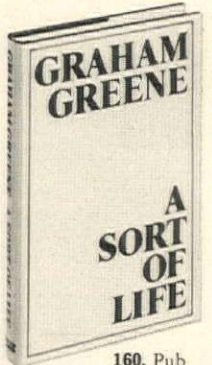

160. Pub price \$6.95

529. A WHITE HOUSE DIARY by LADY BIRD JOHNSON Photographs (Pub list price \$10.95)

A short experimental membership in the **BOOK-OF-THE-MONTH CLUB®** will demonstrate how effectually you can insure yourself against missing the books you are most anxious to read

YOUR CHOICE OF ANY FOUR FOR ONLY \$1

IN A SHORT EXPERIMENTAL SUBSCRIPTION

You simply agree to purchase four additional Club choices within a year at special members' prices

A LIBRARY-BUILDING PLAN EVERY READING FAMILY SHOULD KNOW ABOUT

THE EXPERIMENTAL MEMBERSHIP suggested here will prove, by your own actual experience, how effectually membership in the Book-of-the-Month Club can keep you from missing books you fully intend to read.

As long as you remain a member, you will receive the Book-of-the-Month Club News, a literary magazine each issue of which describes the coming Selection as well as scores of other important books, most of which are available at substantial discounts—up to 40% on more expensive volumes. All of these books are identical to the publishers' editions in format, size and quality. If you wish to purchase the Selection, do nothing and it will be shipped to you automatically. However, there is no obligation to purchase any particular volume. If you do not wish the Selection or any other book offered in the

News—or if you want one of the Alternates—simply indicate your decision on the convenient form provided and mail it so that it is received by the date specified on the form.

If you continue after this experimental membership, you will earn, for every Club Selection or Alternate you buy, a Book-Dividend Credit. Each Credit, upon payment of a nominal sum, often only \$1.00 or \$1.50—somewhat more for unusually expensive volumes or sets—will entitle you to a Book-Dividend® which you may choose from over 100 fine library volumes available over the year. This unique library-building system, together with the sizable discounts on Book-of-the-Month Club Selections and Alternates, enables members to save more than 60% of what they would otherwise have to pay for books they want to read and own.

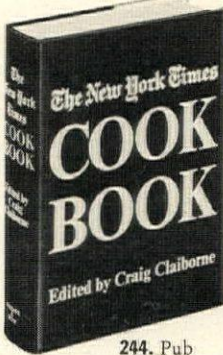

244. Pub price \$9.95

These three count as one book 174. IN SOMEONE'S SHADOW, LISTEN TO THE WARM, STANYAN STREET & OTHER SORROWS by ROD MC KUEEN. (Pub list prices total \$13.50)

BOOK-OF-THE-MONTH CLUB, INC., 280 Park Ave., New York, N.Y. 10017

Time to rejoice. . .

even revel, perhaps, in Carefree Living with high pressure Laminates. Sheen, color, durability for keeps. Soft cushions* float on rubber webbing suspended between chrome-plated rails. Lastingly fresh design by MILO BAUGHMAN. A Debut '72 Collection.

When it comes to modern, THAYER COGGIN thinks of everything.

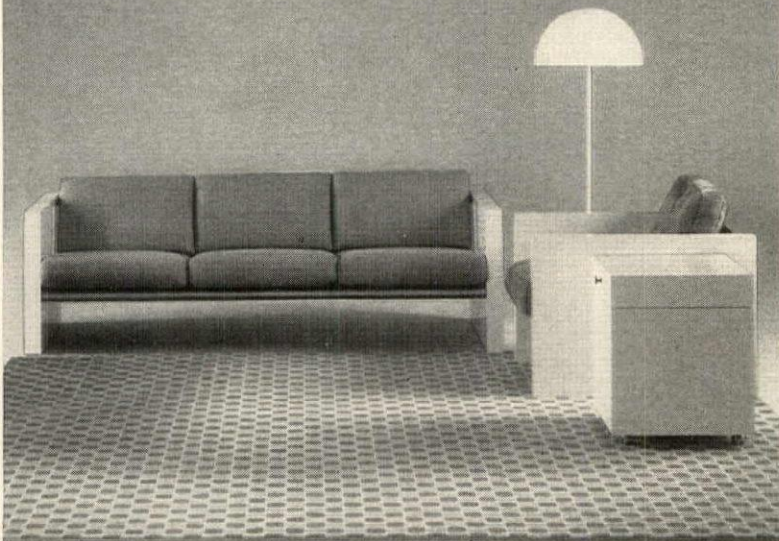

THAYER COGGIN

For a kit of color brochures about Thayer Coggin furniture, send \$1.00 to Hilda Lee, dept. F-1, Thayer Coggin, Inc., South Rd., High Point, N.C. 27262
*Cushions filled with Dacron® polyester

NOTES OF A HAPPY HOUSEKEEPER

continued from page 52

from the hall and putting the Hotable in its place. That not only freed guest space in the other rooms, it gave Jerry the bartender more room to work. He put the bottles and mixers on the cart's pull-out Formica shelves and used the bottom shelf for all the glasses and cocktail napkins. The glass Hotray top became a stain-proof surface to be used for mixing the various drinks.

Now that the abundance of summer is gone, we have to look for **longer-lasting arrangements of fruits and flowers** to dress up the house. I like to fill our oval blue and white bowl with shiny green peppers, satiny white onions, and limes. They can all be used after the first bloom of freshness is gone and in the meantime they brighten up the dinner table. Another of my favorites is the round white Japanese bowl filled with persimmons and black grapes. If you buy the persimmons when they're still almost green they'll probably outlast several batches of grapes, which have a way of falling into the hands of family nibblers. Chrysanthemums have a lengthy lovely season and can be made to last a long time if you cut the stems, trim the lower foliage, and add good old Floralife to the water. If the blooms are *very* fresh to start with, it's possible to enjoy them for two weeks, especially if they are put in china or glass containers. You can get Floralife at most florist shops.

A brand-new, heavy-duty floor cleaner has turned up for those who like freshly scrubbed and waxless kitchen floors or have permanently finished floors. An ammonia-based cleaner, it comes in a pushbutton aerosol can and will clean the dirtiest floors literally in seconds. All you do is spray it on and sponge it off with a sponge mop and clear water. Also good for dedicated wax users when they want to remove old wax build-up before rewaxing. The name is Modern Living and it's made by Essex Chemical Corp. I plan to try it out for other heavy cleaning.

Memo to blanket manufacturers: For months I have been hunting for a replacement for our **king-size electric blanket** and I can't find one with the same generous 14-inch drop on the sides. The best I've been able to locate is a blanket with an 8- or 10-inch drop, which isn't enough to keep out the drafts when someone is under it. So I keep mending the old one and searching.

The road to perfect needlepoint is not always smooth. I have been a slow learner and it took me a long time to realize that ripping out every mistake is the only way to success. So when I suddenly discover that the stitches in my pretty red flower are all going the wrong way, I take up the seam ripper I found in a notion department and cut and rip them back to the beginning of the mistake. Then I use a fine crochet hook to rip out several more stitches until the yarn is long enough to weave into the back with the needle. But using the needle to pick out stitches, I've discovered, tends to split and fray the yarn.



MAJESTIC FLORAL for your WALLS

Beautifully drawn blossoms on a shadowy fern background give THE MARBURY a refreshing new concept in decorative elegance.

Send 50¢ for samples of The Marbury . . . or \$1 for samples PLUS Decorator Kit of wallpaper ideas: 4000-MB Chevy Chase Dr., Los Angeles 90039



AT BETTER INTERIOR DESIGNERS & WALLPAPER DEALERS

THE SUDDEN BLISS OF A LITTLE EXTRA TIME ISN'T EVERYTHING...

With Thermador's Thermatronic Microwave Ranges.
It's Only Part of Your Beautiful Bonanza!

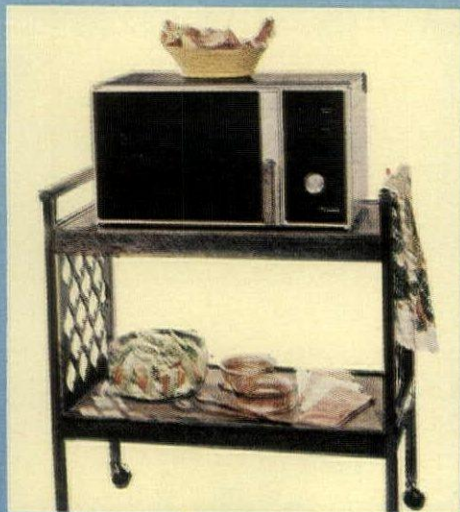

Enjoy the features that make the Thermatronic special:

- Browning Element
- Cooks in shallow metal pans
- Stainless steel interior
- Black glass doors

Elegantly designed models in combination with the self-cleaning oven and single units, all for built-in installation.

Now the portable Thermatronic, Model MC11 is Thermador's handy portable Microwave Range. Its the only one with a browning element. Move it easily to any room in the house . . . or patio . . . wherever there's an electrical outlet. Write for more details.

 **Thermador**
The Elegant Difference



5121 District Blvd., Los Angeles, California 90040

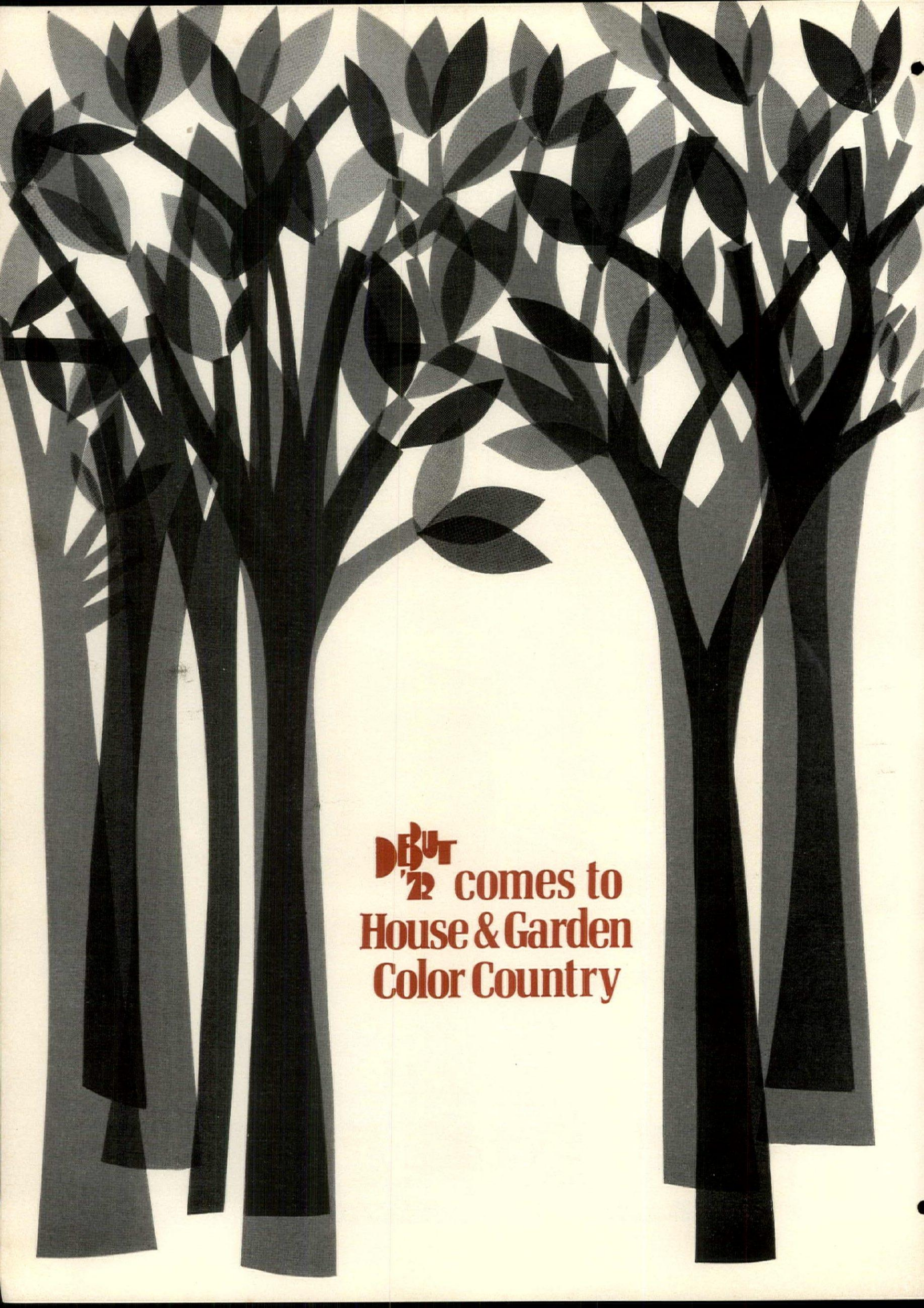

DEBUT
'22 comes to
House & Garden
Color Country

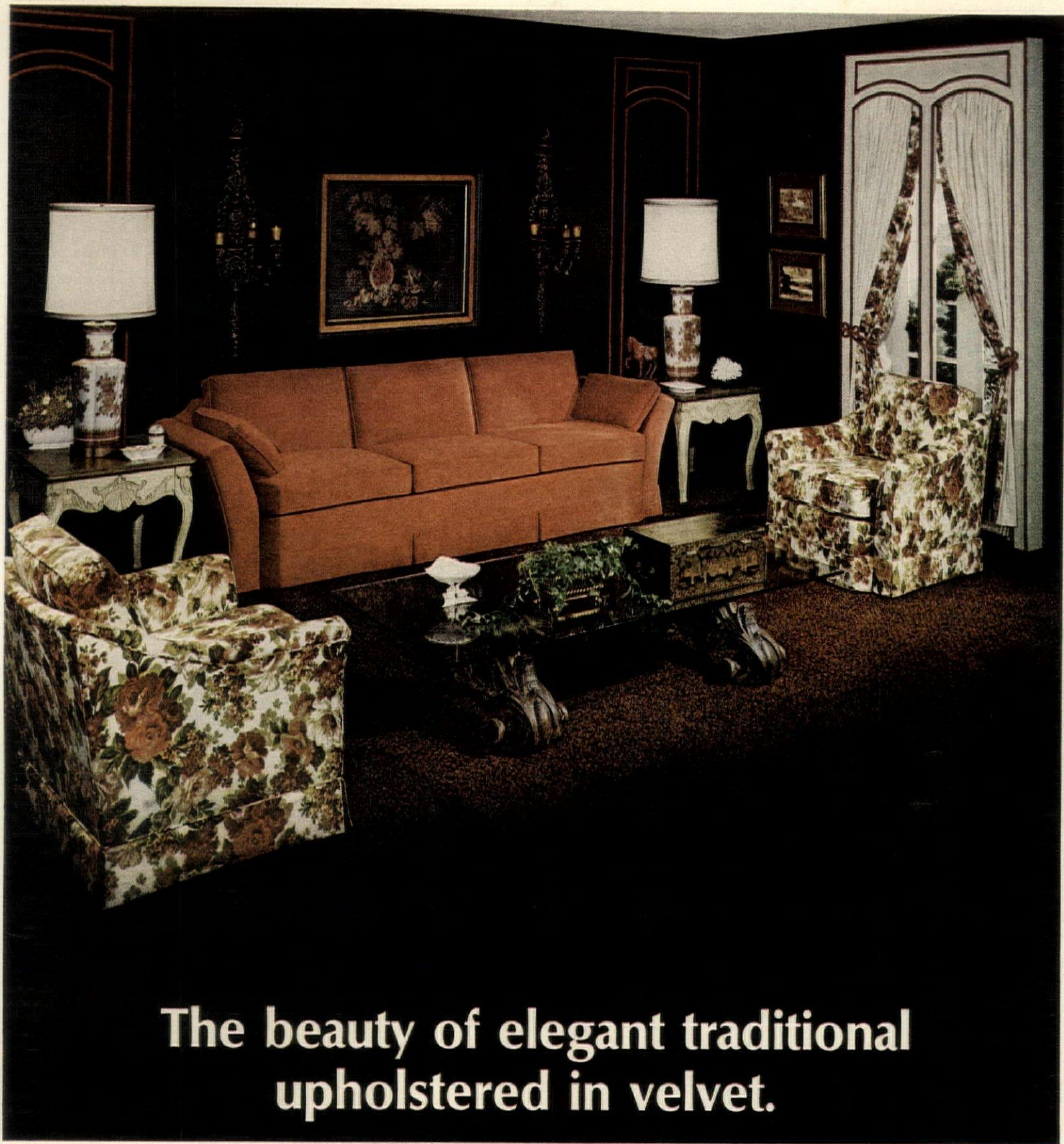

The beauty of elegant traditional upholstered in velvet.

This classic-styled traditional group by Flexsteel features beautiful, long-wearing Dacron® velvet by DuPont. This combination of style and fabric blends true luxury and carefree living into a new standard of excellence for fine furniture.

Each piece features Flexsteel's patented spring construction, solid hardwood frames and the finest upholstery materials. For more information write:

Flexsteel Industries, Inc.
P. O. Box 877
Dubuque, Iowa 52001

DACRON
A DU PONT FIBER

FLEXSTEEL®
FINE UPHOLSTERED FURNITURE

FLEXSTEEL FACTORIES AT . . . DUBUQUE, IOWA; WAXAHACHIE, TEXAS; LANCASTER, PENNSYLVANIA; SALT LAKE CITY, UTAH;
STRATFORD, ONTARIO; NEW HAMBURG, ONTARIO; VANCOUVER, BRITISH COLUMBIA

Norman's makes draperies for you
as if no one viewed the world quite like you.
No one does.



You...and a Norman's specialist. Suddenly you're creating your own window treatments! Combining fabric and pattern in surprising new ways with Norman's unique Fabric Library. Easily. Giving our custom craftsmen your own design. Saying "this is me!" Write Dept. J-4172, Drawer 799, Salisbury, N.C. 28144, for the Norman's specialist near you.



Norman's of Salisbury



DEBUT '72 comes to House & Garden Color Country

All the home furnishings stores listed below feature furniture, carpet and accessories in House & Garden Colors for 1972—and merchandise from participating Debut '72 manufacturers. Visit one of the Color Country stores in your area and bring a part of Color Country home.

ALABAMA

FlorenceBlevins Furniture Co., Inc.
FlorenceLamar's
HuntsvilleMarks-Fitzgerald
MobileGardberg's
MontgomeryCarriage House Interiors

ALASKA

AnchorageFuller-O'Brien Corp.
AnchorageNerland's
AnchorageWolf's Home Furnishings
FairbanksNerland's

ARIZONA

TucsonDorson Furniture Co.

CALIFORNIA

BerkeleyStone-Pierce Co.
BurbankEmpire Furniture
CarmichaelCarmichael Furniture
CoronaKellers Home Furnishings
Costa MesaMartin Furniture
Daly CityWestlake Maple Shop
DinubaMathis & Bolinger
El CerritoTravalini Furniture Co.
FresnoJosephine Furniture Co.
FresnoTurpin's Furniture
FresnoWeinstock's
FullertonGold Furniture Co.
FullertonMcMahan's Furniture Stores
Los AngelesClarke's Furn. Co.
Los AngelesSan Fernando Furniture Co.
Los AngelesSouthern California Furniture Co.
MantecaHafer's Home Furnishings
MontereyFurniture Square
Mountain ViewCarriage House
OaklandE. Bercovich & Son
OaklandBerman's
OrovilleHill Furniture Co.
PasadenaJ. H. Biggar
PasadenaFedde Furniture Co.
PasadenaLowe's
Pico RiveraAbar's Furniture
PomonaJ. H. Biggar
ReddingRoy F. Brown Interiors
SacramentoBrandwein-McMahan
SacramentoModern Furniture Co.
SacramentoWeinstock's
SacramentoWilson's Furniture, Inc.
San FranciscoLachman Bros.
San JoseMartino's Home Furnishers
San Luis ObispoDavidson's Furniture
San PedroForster Furniture

San RafaelCasa Marin
San RosaStone Furniture
Santa AnaJ. H. Biggar
Santa AnaHorton's
Santa BarbaraGarretts Furniture Manor
Santa BarbaraJacobson's Furniture
Santa MonicaAaron-Scott Furniture
Santa RosaPedersen's
StocktonAmerican Home Furn.
StocktonCapitol Furn.
StocktonWeinstock's
TulareMathis & Bolinger
UkiahH & H Furniture Co.

COLORADO

Colorado SpringsHome Furniture
Colorado SpringsF. M. Stark & Co.
DenverVogue Furniture Co.
Ft. CollinsBowling Galleries
GreeleyRuckers Inc.
LongmontHarris of Longmont

CONNECTICUT

AnsoniaSpector Furniture
BridgeportBreiner Furniture
DanburyHenry Dick & Son
DanburyHowland
East HartfordCalano Furniture, Inc.
GrotonShafner's Furniture Store
ManchesterWatkins Bros. Inc.
MeridenMeriden Auction Rooms
MilfordWayside Furniture
NaugatuckTalevi's
New HavenThe H. M. Bullard Co.
New HavenThe Edward Malley Co.
New HavenYale Furniture Co., Inc.
New LondonShafner's Furniture Store
NorwichSilberman Furniture Co.
OrangeAlexander's Furniture Shop
SeymourSeymour Furniture Co.
SouthportFreedman's of Southport
StamfordSilberman's
TerryvilleTerryville Furniture Store
WethersfieldModern Living Furniture

DELAWARE

WilmingtonH. Feinberg's

DISTRICT OF COLUMBIA

WashingtonColony House
WashingtonCurtis Bros.
WashingtonHub Furniture
WashingtonLansburgh's
WashingtonMazor Masterpieces
WashingtonW & J Sloane

Continued on page 62



to the most living,
t to be Fox.



Fox builds furniture to last. And we've been building it that way for 65 years.

There's Fox Mediterranean. Fox Contemporary. And Fox American Provincial. All easy-to-care-for, wonderfully affordable collections.

You can probably see the entire Fox line the next time you drop in at your favorite furniture store. In the meantime, why not send for the Fox Portfolio? It only costs fifteen cents, and it's got all sorts of new ideas and suggestions on decorating. Plus lots of good stuff about Fox.

The furniture you can live with.
From now on.



FOX



Furniture for people who do a lot of living.

Enclose 15¢ in coins and mail to Fox Manufacturing Co., Dept. HG, P.O. Box 753, Rome, Georgia 30161

Name _____

Address _____

City _____

State _____ Zip _____

FLORIDA

DaniaBaer's Furniture Co.
 Ft. LauderdaleBaer's Furniture Co.
 Ft. LauderdaleCarl's Furniture Inc.
 Ft. PierceGrant Furniture Co.
 Leesburg..Boyd's Furniture, Carpets & Gifts
 MiamiPearl's Furniture Corp.
 NaplesFurniture Fashions
 PalmettoWhittle's of Palmetto
 St. PetersburgKanes Skymart Inc.
 St. Petersburg Lew Bros. Standard Furn. Co.
 SarasotaSavon Furniture
 TampaKanes Furniture Plaza
 Vero BeachGrant Furniture Co.
 West Palm BeachGrant Furniture Co.
 West Palm Beach..J. J. Cater Furniture Co.

GEORGIA

Albany ...Albany Housefurnishing Co., Inc.
 AlbanyCarter Home Furnishings
 AthensJohn Thurmond Furniture
 AtlantaCarriage House Furniture
 AtlantaDavison's
 AtlantaSoutheast Wholesale Furn. Co.
 AtlantaSterchi Bros. Furniture Co. Inc.
 DaltonBarganier's
 FitzgeraldHome Furniture Co.
 MaconEmpire Furniture Co.

HAWAII

Kahului MauiNerland's

IDAHO

NampaTerry's Home Furnishings
 PayetteSteiniker's Quality Furniture

ILLINOIS

AuroraLeath Furniture
 BelvidereLeath Furniture
 BloomingtonLeath Furniture
 ChampaignKecck's Furniture
 ChicagoThe Contemporary Shop
 ChicagoDistrict Furniture & Appliance
 ChicagoGately's Peoples Store
 ChicagoJulian Furniture & Interiors
 ChicagoLe May Furniture Co.
 ChicagoRestano Furniture & Interiors
 ChicagoJohn M. Smyth Company
 ChicagoTown House Interiors
 DanvilleLeath Furniture
 DecaturLeath Furniture
 De KalbLeath Furniture
 DixonAmes Furniture
 DixonKreim's Furniture Co.
 DundeeDundee Furniture & Rug Center
 ElginLeath Furniture
 FreeportLeath Furniture
 GalesburgLeath Furniture
 GurneeLeath Furniture
 JolietLeath Furniture
 KankakeeHome Appliance
 KankakeeLassers Furniture Co.
 KewaneeGood's Furniture House
 MolineLeath Furniture
 Morton Grove
 Northern Home Furnishings Co.
 No. AuroraSimons Furniture Co.
 PekinLeath Furniture
 PeoriaAdams Furniture
 PeoriaCohen Furniture Co.
 PeoriaLippmann's Furniture & Interiors
 PeoriaSiegrist Furniture & Appliances
 RockfordLeath Furniture
 Rockford-North TowneLeath Furniture
 Rockford..Rockford Standard Furniture Co.
 SpringfieldLeath Furniture
 SterlingDunbar Furniture & Interiors
 SterlingLeath Furniture
 WatsekaLassers Furniture Co.

WaukeganLeath Furniture
 WheatonCarriage House Inc.
 WheatonThe Toms-Price Co.

INDIANA

AndersonLeath Furniture
 BlufftonThoma Furniture
 ConnersvilleHolthouse Furniture
 Ft. Wayne ...Adams & Walda Furniture Co.
 Ft. WayneKaplan Furniture Co.
 Ft. WayneLeath Furniture
 FranklinHolthouse Furniture
 GaryLeath Furniture
 GoshenBaer's Home Outfitters Inc.
 GrabillSouders' Home Center
 GreensburgHolthouse Furniture
 GreensburgRex Peoples Furniture Co.
 IndianapolisBowman Furniture, Inc.
 IndianapolisKelly Furniture Co.
 Indianapolis
 Kittles Home Furnishings Center
 Indianapolis
 Ludlows Modern Furniture, Inc.
 KendallvilleBerhalter Furniture Inc.
 KendallvilleKendallville Furniture
 KokomoLeath Furniture
 LafayetteReifers Furniture Co.
 La PorteBaer's Home Outfitters Inc.
 La PorteFenker & Co.
 MarionLeath Furniture
 MarionStewarts Furniture
 MuncieCountry House
 MuncieLeath Furniture
 New AlbanyReisz Furniture Co.
 New CastleBrammer-Jacobs Furniture
 New CastleHolthouse Furniture
 PeruWallace Furniture
 PortlandHolthouse Furniture
 Rensselaer
 Hoover House Furniture & Carpet
 RichmondHolthouse Furniture
 South BendBaer's Home Outfitters Inc.
 South BendRies Furniture Co.
 ShelbyvilleHolthouse Furniture
 ValparaisoValparaiso Furniture Co.
 WabashLeath Furniture
 WinchesterHolthouse Furniture

IOWA

Cedar RapidsHall Home Furnishings
 Cedar Rapids..Hilltop House Furniture Inc.
 Cedar RapidsSmulekoff's
 Charles City..Sylvester's Furniture & Floors
 DavenportLeath Furniture
 Des MoinesYounkers'
 DubuqueLeath Furniture
 MarshalltownHome Furniture Co.
 Marshalltown
 McGregor Home Furnishing Stores

KANSAS

Dodge CityHulpieu-Miller Interiors
 LenexaDuff & Repp
 MarysvilleSanders Furniture Co.
 Prairie VillagePilgrim House
 TopekaEd Marling Stores

KENTUCKY

AshlandParson's Furniture Store, Inc.
 CovingtonLouis Marx & Bros.
 CovingtonModern Furniture Company
 CovingtonTillman Furniture Co. Inc.
 LexingtonBurke Furniture, Inc.
 LouisvilleBensinger's
 LouisvilleEvans Furniture Co.
 LouisvilleHubbuck in Kentucky
 Louisville..Middletown Furniture Showrooms
 MadisonvilleJordan Furniture Co. Inc.
 MiddletownFurniture Showrooms
 Mt. Sterling
 Carrington Furn. & Appliance Co.

**"A summerhouse sofa has to seat people with wet hair and bare feet.
It also has to sleep two. Comfortably?"**

"That's why we chose a Hide-A-Bed® sofa.

It's everything it should be. And more.

What more?

More beautiful. More comfortable. More custom-made-for-me than any other sofas I looked at.

Sure, I looked around. I don't think a sofa is something you buy on an impulse. I compared. And I found Hide-A-Bed sofas had more to offer.

More styles, for one thing. The whole range. From casual to formal. From Modern to Colonial. (From \$200 to \$1400.) Almost every kind of sofa you could think of. And a few you couldn't. Like this one.

Then they've got over 400 fabrics to choose from. Only I stopped looking when I found this one. It was love at first sight. And—it was already treated for stain resistance. Which means when people relax and put their feet up, I can relax, too!

And then, of course, the hidden bed.

In your choice of widths, from single to Super size. And best of all, the mattress is Simmons! You can pick a Regency® or a Beautyrest® mattress.

And you know how comfortable *they* are.

Anyway, *we* know.

Our guests always sleep late."

SIMMONS



For decorating booklet, "Hide-A-Bed Sofas for the Way We Live Now," send name, address and 25¢ to Simmons, 2 Park Avenue, N.Y.C. 10016.



Sofa shown: Infinity-4. White molded fiberglass frame with black plinth base. Cushion fabric: 8930 Parrot Green. About \$910. Prices start at \$895. From Graceline Collection. Fabric protected by ZEPPEL Soil/Stain Repeller.

When Simmons can give you the sofa you want, isn't it nice there's a bed in it, too?

**THE HIDE-A-BED SOFA BY SIMMONS
FOR THE WAY WE LIVE NOW.**



The Magnificent Impostor by Berkline.

Look at him. Sitting and waiting. But he's resigned to it. As long as he can sit and wait comfortably. In a Berkline. The rocking recliner that doesn't look like one. She planned it that way. Because she knew the Impostor would show off for her. And lean back with him. What better way to keep him calm while he's waiting for her to get dressed. Just one from the Mayfair collection by Berkline. See them at a dealer near you. Send 25¢ for a color brochure to The Berkline Corporation, P.O. Box 100, HG-2, Morristown, Tennessee 37814.



BERKLINE

LOUISIANA

- AlexandriaHemenway Home Furnishers
- Baton RougeHemenway Home Furnishers
- Baton RougeJoy's
- LafayetteDauterive Furniture Co., Inc.
- Lake Charles.....Hemenway Home Furnishers
- New Orleans...Hurwitz-Mintz Furniture Co.
- New Orleans...Morris Kirschman & Co., Inc.
- New Orleans...Lafayette Furniture Co., Inc.
- New OrleansNu-Idea Furniture Co.
- ShreveportHemenway Home Furnishers
- WestwegoBon Marche Furniture Co., Inc.

MAINE

- PortlandYoung's Furniture Co.

MARYLAND

- BaltimoreB. Bugatch Stores, Inc.
- BaltimoreLevenson & Klein Inc.
- BaltimoreMartin's Furniture
- BaltimoreNational Furniture Co.
- BaltimoreM. Shaivitz & Sons
- BaltimoreShofer's Furniture Co., Inc.
- CambridgeDean's Furniture
- Cumberland...L. Bernstein Furniture Co., Inc.
- Damascus...Cain's Early American Furniture

MASSACHUSETTS

- AdamsA. C. Simmons Inc.
- AuburnGoodwin's Carriage House
- CambridgeHedin Furniture Co.
- DanversYoung's Colonial Manor
- FraminghamGoodwin Furniture
- LawrenceWeiner Furniture Co. Inc.
- LowellHousehold Co.
- LynnSaxony House Furniture
- LynnYoung's Furniture Co.
- MaldenKotzen's Furn.
- New BedfordAlpert's Fine Furniture
- No. PembrokePembroke House
- No. Quincy...Dudley Furniture & Appliances
- RoslindaleAllen Furniture Co.
- SpringfieldEdwards Wayside Furniture
- StonehamSloane Furniture Co.
- WakefieldWakefield Colonial Shop

MICHIGAN

- AdrianWalper Furniture
- AlmaTrower Furniture Co.
- AlpenaAlpena Furniture
- Ann ArborHolland House Furniture
- BangorSherrord's Furniture & Carpet
- Bay CityC. E. Rosenbury & Sons
- Benton HarborLeath-Neuland
- Benton HarborLewis Furniture
- ChesaningBueche Furniture
- ColdwaterMcKinley's 1876 House
- DearbornDaly Brothers
- DetroitEnglander Triangle
- DetroitPeoples
- DetroitTrees Furniture
- Drayton PlainsThomas Furniture Co.
- FarmingtonRay Interiors
- FerndaleEnglander Triangle
- FlintPierce Furniture Co.
- GladwinRice Furniture
- Grand Rapids...Galewood Home Furnishings
- Grand RapidsHuizingh's Furniture
- HartfordConklin's Home Furnishings
- Imlay CityImlay City Furniture Store
- JacksonShaw's Furniture Inc.
- JacksonVermeulen Furniture, Inc.
- KalamazooCentral Furniture Co.
- KalamazooHome Furnishings Company
- KalamazooNational Furniture Co.
- KalamazooSharpe's Colonial House
- LansingBishop Furniture Co.
- LivoniaThe Hearthside
- LivoniaHouse of Maple Inc.
- MasonBall-Dunn Home Furnishings

- MorenciMeyer's Furniture Store
- Mount Pleasant...Bonnell Superior Furniture
- MuskegonPine St. Furniture
- Port HuronLeath Furniture
- Royal OakEdward Furniture Co. Inc.
- SaginawLeath Furniture
- St. Clair ShoresDraper's Fine Furniture
- St. JosephTroost Brothers Furn.
- SouthfieldGormans Gallery, Inc.
- Sterling HeightsNewman Furniture Inc.
- SturgisBigelow Furniture Co.
- SturgisSigrist's Furniture Co.
- Traverse CityWilson Furniture Co.
- UticaSchwark Furniture
- WarrenSterling Furn. Co.
- WayneW. L. Gates Furniture Co.

MINNESOTA

- FountainDrury's Inc.
- MankatoGosewisch Bros. Inc.
- MankatoLandkammer Bros. Co.
- MinneapolisGamble Skogmo Inc.
- St. Paul...Schumeister's Furniture Minnesota
- WillmarWillmar Hi-Way Furniture Co.

MISSOURI

- Cape GirardeauRust & Martin, Inc.
- CharlestonEconomy Furniture Co.
- FlorissantCousins Furniture Co.
- Jefferson CityMilo H. Walz, Inc.
- Poplar Bluff
Andersons' Home Furnishings, Inc.
- SedaliaHomakers, Inc.

MONTANA

- BillingsElliot's Inc.
- HavreValley Furniture Co.

NEBRASKA

- LincolnMiller & Paine

NEVADA

- RenoWeinstock's
- Zephyr CoveDayton's Furniture

NEW HAMPSHIRE

- Laconia...Chertok-Lougee Robinson Co., Inc.
- PortsmouthMargeson's Inc.

NEW JERSEY

- BerlinDougherty's Furniture Store
- DoverFurstman & Feinberg Inc.
- East PatersonKorvettes
- ElizabethFricke Furniture Co.
- ElizabethMcManus Bros.
- ElizabethRockford Furn. Co.
- NewarkBorok & Son Inc.
- NewarkRockford Furn. Co.
- NutleyKastner's Furniture Inc.
- PatersonBograd Bros.
- PatersonRobak Decorator Showrooms
- PennsaukenTriad Furniture Co., Inc.
- ShipbottomOskar Huber Inc.
- SuccasunnaSuburban Furniture
- SummitZeigner's of Summit
- TrentonPark Lanz Furniture
- UnionThe Mart Furniture Galleries
- WillingboroR. M. Edwards Co.
- WoodbridgeRockford Furn. Co.

NEW MEXICO

- AlbuquerqueEckert's
- AlbuquerqueAmerican Furniture Co.

NEW YORK

- AlbanyJohn B. Hauf Inc.
- AlbanyHouse of Montague
- AlbanyMayfair, Inc.
- AlbanyStandard Furniture
- AlbanyA. Swire Furniture
- Amsterdam ...Charles Olender & Sons Inc.



DEBUT '72 TOTAL LOOK

is built into Tell City MixAbles

Beautiful rooms like these almost create themselves when you start with Tell City Early American. Hundreds of pieces—lamps, accessories, furniture for every room—are all decorator-coordinated to mix beautifully together. You can suit your life-style, your home, even your whims. Go a little wild. You can't go wrong. Debut '72 calls it the Total Look. We call it MixAbility. Either way, it's the modern trend in decorating.

See all the MixAbles and dozens of Early American rooms like these in the Tell City "Primer of Early American Home Decorating." Ask your Tell City dealer or send \$2.00 to Tell City Chair Co., Box HU, Tell City, Indiana 47586.

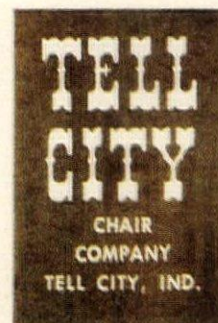

FURNITURE CRAFTSMEN
SINCE 1865



We're out to impress you,
but not with our name.

When you walk into a furniture store, you're immediately impressed by certain pieces of furniture. No names—just the furniture . . . the style, craftsmanship, and design are striking. That's the kind of furniture we make at Hammary. But we're not interested in impressing you with our name. We're interested in impressing you with our furniture. We make furniture that sells itself. Send 50¢ for a distinctive brochure to Hammary Furniture, Div. U.S. Industries, Inc., Dept. 2, Lenoir, North Carolina 28645.

HAMMARY

It's not our name that sells our furniture.

Continued from page 64

- Bath Fagan's Furniture Inc.
 Binghamton The Fair Store
 Brooklyn Peoples Americana
 Brooklyn Pincus Decorators Inc.
 Buffalo Cape Cod Shop
 Buffalo Hansom House
 Buffalo F. Scherer & Sons Inc.
 Camillus Roth Bros. Manor House
 Chatham Chatham Furniture
 Dewitt Roth Bros. Manor House
 Elmira Edgecomb's Carriage House, Inc.
 Elmira Peterson's Furn. Stores, Inc.
 Fonda Duross Bros. Inc.
 Herkimer Howland
 Hilton Marple Furniture Inc.
 Horseheads Hample Interiors
 Huntington Station Jefferson Carriage House
 Jamestown Field & Wright
 Mineola Gensel's Wayside Furniture
 Mt. Kisco Mt. Kisco Furniture
 New Hartford Carriage House
 New Hartford J. B. Well's Home Store
 New York Sachs New York
 Niagara Falls Arnon Furniture Co.
 Niagara Falls Levy Bros. Furniture Co., Inc.
 Oneonta Bresee's Oneonta Dept. Store
 Oswego Browne-Davis, Inc.
 Port Chester Tunick's Furniture Store, Inc.
 Port Jervis Levin Furniture Co. Inc.
 Poughkeepsie Sherman's Furniture
 Rochester Bayles Furniture
 Rochester Flanigan Furniture
 Rochester McNall's Furniture Galleries
 Rochester Northside Furniture
 Rochester Ruby-Gordon, Inc.
 Scarsdale The Maple House
 Schenectady Breslaw's
 Schenectady Robinson Furniture
 Syracuse Dunk & Bright Furniture Co.-Bright Horizons
 Utica Carriage House
 Utica Grace Furniture Co.
 Utica E. Tudor Williams Inc.
 Vestal Love Furniture
 Warsaw Zeches Inc.
 White Plains J. H. Harvey Inc.
 White Plains Howland
 Williamsville Country Manor Drexel Galleries
- NORTH CAROLINA**
 Aulander Aulander Furniture Co.
 Burlington Canady Wayside Furniture
 Burlington Colonial Furniture Co., Inc.
 Chapel Hill Johnson-Strowd-Ward
 Hendersonville Brunson Furniture Co.
 High Point Annex Furniture Galleries
 High Point Boyles Furniture Sales, Inc.
 High Point Paramount Furniture Co., Inc.
 High Point Rose Furniture Co.
 Raleigh Caraleigh Furniture Co.
 Sanford Sprott Bros. Furn. Co.
 Warrenton Warrenton Furniture Co.
 Wilmington Furniture City
 Winston-Salem State Furniture Co.
- NORTH DAKOTA**
 Fargo Furniture City
 Williston Conlin's Furniture
- OHIO**
 Akron Polsky's
 Akron Marvin Wollins Furniture Inc.
 Ashland Gilbert Furniture
 Ashtabula Carlises
 Bluffton Basinger Furniture, Inc.
 Bucyrus Wm. Wise & Sons
 Chillicothe Ebenhack & Son
 Cincinnati Bigner Furniture
 Cincinnati Springfield House, Inc.
- Cincinnati Sun Furniture & Appl. Co.
 Cleveland Leopold Bros. Furniture
 Cleveland Mantel & Goetz Furniture & Interiors
 Columbus Ci Bon Furniture
 Columbus Durrants Furniture, Inc.
 Columbus Glick's Furniture
 Columbus Haas Furniture Company
 Columbus Sears, Roebuck & Company
 Covington Sellman Furniture & Carpet Co.
 Dayton Day's Carriage House
 Fremont Tschumy's Interiors
 Findlay Brindles Wayside Furniture Co.
 Greenville Holthouse Furniture
 Laura Roark Furniture
 London Dwyer Bros., Inc.
 Mansfield Penny Pearson Furniture Co.
 Maple Heights The Janda Furniture Co.
 Massillon Finefrock of Massillon
 Maumee Rogers Furniture City
 Mentor Pummel's Home Furnishings
 Napoleon George's Furniture Co.
 New Carlisle Trostel's Home Furnishings
 Niles Carlises
 Piqua Holthouse Furniture
 Sandusky Herman's Furniture & Colonial Shoppe
 Sylvania Pioneer Tradition House
 Tiffin The Furniture Shop, Inc.
 Tipp City Thornton's Inc.
 Toledo The Buckeye Furniture Company
 Toledo Ideal Furniture
 Toledo Johnson's Fine Furniture
 Toledo Walker Furniture
 Washington, C. H. Holt-House of Furniture
 Wauseon Randolph Furniture Co.
 Westerville McVey Furniture
 Youngstown Furnitureland of Youngstown
 Youngstown Haber's
- OKLAHOMA**
 Ada Campbell's Furniture & Decorating
 Bethany Keener's Ye Olde Early American Shoppe
 Lawton Christopher's Home Furnishings
 Norman Norman
 Landsaw's of Norman, Furniture & Interiors
 Norman Town & Country Furniture
 Oklahoma City Borthicks Furniture
 Oklahoma City Callaway's Home Furnishings
 Oklahoma City O. Davis Furniture Co.
 Oklahoma City Knight Furniture, Inc.
 Oklahoma City Mathis Bros. Furn.
- OREGON**
 Corvallis Blackledge Furniture
 Corvallis Furniture Village
 Eugene Rubenstein's of Oregon
 Portland Smith's Home Furnishings Inc.
 Portland Tarlow Furniture Co., Inc.
- PENNSYLVANIA**
 Altoona Wolf Furniture Co.
 Ambridge Economy Furniture Co.
 Bellefonte Brachbill's
 Berlin Johnson & Son Furniture Co.
 Erie Arthur F. Schultz Co.
 Finleyville Finleyville Furniture Co.
 Gettysburg Sixeas Furniture
 Harrisburg M. Lee Goldsmith Inc.
 Lancaster Oblender's Inc.
 Lancaster Plastino & Owens Inc.
 Leesport Village Furniture Galleries
 McKeesport R & J Furniture Co.
 McKeesport Wander Sales
 McMurray Manor House
 Meadville J. H. Nunn Co., Inc.
 Monroeville Faller Furniture
 Mt. Carmel Guinan's Dept. Store
 New Castle A & M Westgate Furniture, Inc.

Continued on page 68
HOUSE & GARDEN



Forget what mama liked.



Because things have changed. Mama couldn't have subtle Marquise. Smoky and sophisticated. It's brand new. On a Jewelite Chrome pedestal. With matching chairs that swivel. Think of it. Getting up and down at the table gracefully. Then there's Marquise's counterpart, crystal clear Tiffany. And a smart new matching bar ensemble. Chromcraft has more exciting designs in dining and entertaining furniture than you've ever seen before. See them today at any good furniture store. Or write us.

CHROMCRAFT, INC.

SENATOBIA, MISSISSIPPI 38668

Send 25¢ for a full color brochure of dining for the 70's.

Name

Address

City

State Zip

This lush lap of luxury is probably the most comfortable swivel based lounge chair you can find. Yet, for all the depths of comfort Barrelmaster sinks to—it never loses sight of appearances. The molded base is in a choice of practically indestructible lacquer colors, black or walnut mylar. And Selig covers it in a seemingly limitless range of fabrics or vinyls. Try a Barrelmaster. Once you experience its luxurious leisure, you're sunk.

The Barrel Master Once you try it, you're sunk.

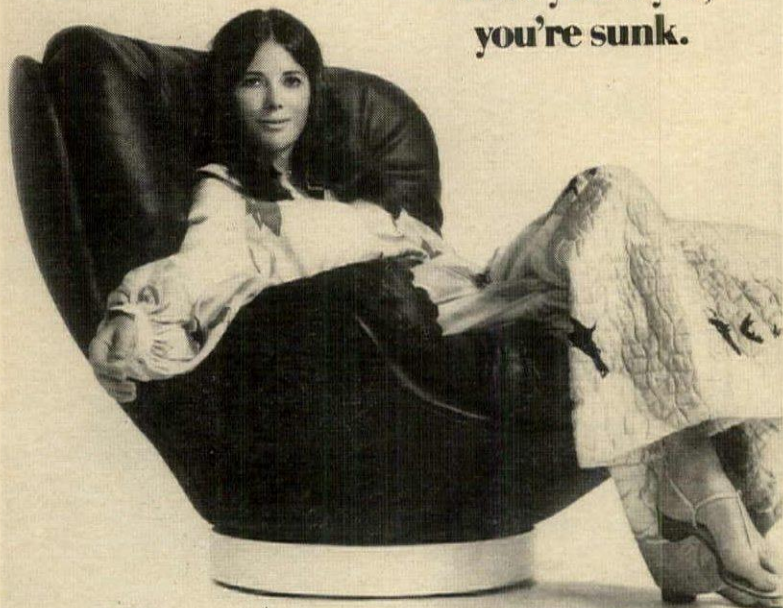

For our completely new folio of fine designs, send \$1.00 to Selig Manufacturing Company, Leominster, Mass. Showrooms to the trade: New York, D & D Building; Chicago, Merchandise Mart; San Francisco, Ice House; and at better stores everywhere.

SELIG

Your space, your taste, your budget.

Furniture scaled smaller to fit modern apartments. Or full size for spacious, gracious homes.

Maxwell Royal furniture fits the Debut '72 image with deep, cushiony comfort and smartly tailored fabrics you'll love to live with. Like the 3-D407 sofa pictured.

And (surprise!) Maxwell Royal is priced to please.

Whether you choose the exposed maple solidity of new Chatham Square, the rustic pine of Boone Trail, or tasteful Traditional, you'll be selecting furniture built to last thousands of tomorrows.

From Maxwell Royal . . . furniture that fits.

Perfectly.

Write for the name of your Maxwell Royal dealer.



MAXWELL ROYAL CHAIR COMPANY
HICKORY, NORTH CAROLINA 28601

Continued from page 66

New Castle Haney Furniture Company
Philadelphia Murta's Furniture
Philadelphia Oskar Huber Inc.
Pittsburgh May Stern & Co.
Pittsburgh Mutual Furniture Center
Pittsburgh Rollins Furniture Inc.
Pittsburgh Stern's
Pittsburgh Today's Home
Quakertown Smith's Furniture
Rockwood Henry's of New Centerville Inc.
Sharon Willson's Inc.
Southampton Oskar Huber Inc.
Uniontown Chesler's Furniture
Uniontown Cohen Furniture
West Chester Kauffman's
Wilkes-Barre Fowler, Dick & Walker
Wilkes-Barre United Furniture
Wilkes-Barre Faller Furniture

RHODE ISLAND

Providence Roitman & Son Inc.
Tiverton I. F. Morin Furniture, Inc.

SOUTH CAROLINA

Andrews Andrews Furniture Co. Inc.
Belton Maynard's of Belton
Charleston Southeastern Galleries
Columbia Colony House Furniture Co. Inc.
Columbia Rosewood East
Columbia James L. Tapp Co.
Greenville Tate Furniture Co.
Loris Carolina Furniture Co. Inc.
Loris Loris Radio & Appl. Inc.
Newberry The Home Furn. Co.
Prosperity Prosperity Furniture Co.
Spartanburg Hammond-Brown-Jennings

SOUTH DAKOTA

Sioux Falls Donahue Furniture

TENNESSEE

Bristol Gurley's Homestead House, Inc.
Bristol Home Furniture Co.
Chattanooga Fowler Bros.
Knoxville American Home Furniture Co.
Knoxville Woodruff's, Inc.
Manchester Pittman's Furniture Center
Nashville Beesley Furniture Co., Inc.
Nashville Harley-Holt Furniture Co.
Nashville Tennessee Maytag & Furniture Corp.

TEXAS

Amarillo Herring Furniture Company
Austin Cabanis Brown Showcase Store
Baytown Culpepper Furniture Co.
Brownsville Edelstein's Better Furniture
Coleman J. E. Stevens Co.
Dallas Adele Hunt Inc.
Dallas Liberty House
Dallas Milmac Furniture
Dallas Rex Homestead House
Ft. Worth Ellison-Obid
Ft. Worth Sam's Appliances & Furniture Inc.
Ft. Worth Southwest Furniture & Carpet Co.
Greenville Collins-Hilton Furn.
Houston Finger Furniture Co., Inc.
Houston Foley's
Alameda Foley's
Northwest Foley's
Sharpstown Foley's
Houston Georgetown Manor
Houston Suniland Furniture Company
Irving Fowler's Inc.
Kenedy Stimson Furniture Co.
Kerrville Crick's Inc.
Kerrville Fawcett Furniture Co.
Kerrville J. W. White
Lubbock Edlers Inc. Furniture
McAllen Strouds Home Furnishings

Mt. Pleasant Boatner's Home Furniture
Odessa Casstevens Furniture Company
Paris Cox Furniture & Decorators
Pasadena Norman Furniture Co. Inc.
San Antonio DuBose-Acme Floors
San Antonio Toudouze
Temple Temple Furniture Company
Tyler Pope and Turner Inc.
Vernon Dollar Down Furn. Co.
Victoria Stimson Furniture Co.
Wichita Falls Golden's Home Furnishings

UTAH

Cedar City Antones Interiors
Ogden Madsen Furniture & Interiors
Salt Lake City Madsen Furniture & Interiors

VERMONT

Burlington Vermont Mattress & Furniture Co. Inc.

VIRGINIA

Arlington Colony House
Colonial Heights The Crafer House Furniture Co.
Danville Clements & Parker Inc.
Falls Church Naomi Totten Furniture
Front Royal McLaughlins Furn. & Antiques
Hampton Midway Stores, Inc.
Hampton Wythe House
Martinsville Stan Finney, Inc.
Norfolk Louis Legum
Portsmouth Louis Legum
Richmond Hawkes Furniture Corp.
Richmond Holladay House Furniture Inc.
Richmond Furniture City of Richmond
Springfield Williams Wayside Furniture
Virginia Beach Louis Legum
Waynesboro J. L. Barksdale Furniture Corp.

Woodbridge Williams Wayside Furniture

WASHINGTON

Aberdeen Kaufman Scroggs Co.
Bremerton Kaufman-Lebo Co.
Raymond Jensen Furniture Co.
Seattle Howard's Furniture
Seattle K. C. W. Furniture Store Inc.
Seattle Olsen Furniture
Spokane Burgans Furniture
Tacoma Schoenfeld's Furniture
Tacoma Selden's

WEST VIRGINIA

Beckley Hall Furniture
Charleston The Diamond
Charleston National Furniture Co.
Man The Hensley Furniture Co., Inc.
Parkersburg Reps Furniture Co.
So. Charleston McClung & Morgan Stores Co.
Williamson B & L Furniture Co.

WISCONSIN

Appleton Leath Furniture
Baraboo McGann-Kurtz Co.
Beloit Leath Furniture
Brookfield Carriage House
Cuba City Donohoo's of Cuba City
Eau Claire Leath Furniture
Fond du Lac Leath Furniture
Janesville Leath Furniture
Kenosha Bode Bros. Co.
La Crosse Leath Furniture
Madison Leath Furniture
Madison-South Gate Leath Furniture
Milwaukee Bilt Rite Furniture Co.
Milwaukee Hack Furniture Unlimited
Milwaukee Klode Furniture Co.
Milwaukee Kunzelmann-Esser Co.
Oshkosh Leath Furniture
Racine Paulson's
Wausau Leath Furniture

RIO GRANDÉ



Paneling with the warmth and spirit of the sun country!

Rio Grandé. Handsome, rugged. With the weathered good looks of the great Southwest. It comes in five sun-drenched, earth colors: Leather. Sage. Adobe. Bone White. Bronze. And enough to cover a 12' x 8' wall costs as little as \$21.00. Bring the warmth of the desert sun into your home. With Rio Grandé paneling. You'll find it at your nearby Georgia-Pacific dealer. Stop by and pick up your free paneling idea booklets. For the name of your nearest Georgia-Pacific dealer, call 800/243-6000. In Connecticut, call 800/942-0655.

 **GEORGIA-PACIFIC**
PORTLAND, OREGON 97204



Paneling with the great American look.
From Georgia-Pacific.

624 ideas for decorating with lighting by Progress

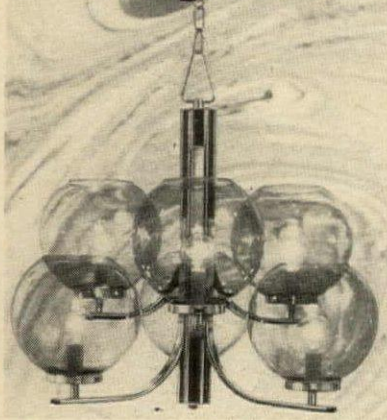

P-4055, black and chrome, smoked glass. About \$100.



P-4348, Mediterranean wrought iron. About \$110.

A new chandelier is a wonderfully inexpensive way to give a new look to your rooms. Modern, Traditional or Mediterranean . . . you'll find hundreds of ideas, for every room, in our lighting fashions catalog. Match any mood and budget with Progress, world's largest manufacturer of home lighting. Check the Yellow Pages under "Lighting" for the Progress showroom nearest you. Go there for expert advice.



See the newest lighting ideas in our 120 page, full color catalog.

Send 50¢ today to:

Progress Lighting, Dept. G-13,
Box 12701, Phila., Pa. 19134

Name _____
Street _____
City _____
State _____ Zip _____

progress[®]
LIGHTING
Division of LEA

NOTES TO HELP YOU DECORATE-IT- YOURSELF

BY PATRICIA CORBIN

I want to have matching shades and curtains in my bedroom, but there isn't going to be enough of the flowered fabric to go around. Is there a way to border the shades with strips of the material so that they match the curtains?

You could save whatever bits of the flowered material are left over from making the curtains and then use this to appliqué your shades. You could make an all-over design of the flowers, but not as densely patterned as your curtains. Buy shades that are the background color in your print; then cut out as many flowers as you can from the left-over material and paste them on the shades. To keep the edges of the flowers from raveling, paint the cutting line, on the back, with colorless nail polish before cutting. (Or if your material has bunches of flowers, spray each bunch to be cut out with Krylon, a clear acrylic spray.) Use small, sharp scissors for cutting and arrange pieces as a complete design on the shades. Use an adhesive glue that will remain flexible when dry so that the whole shade can easily be rolled up. Bond Cement Number 6793 is excellent for this kind of appliquéing.

There is a radiator in our bedroom in just the spot I would rather have a desk. Can I cover the radiator with a surface that could be used as a desk top?

You could use a Parsons table over the radiator if you line the underside with asbestos. Choose a table that is high enough to clear the radiator and deep enough for all your desk paraphernalia. Then paint the Parsons table and the radiator the same color as the walls.

How do you arrange a room around a baby grand piano?

A room has to be balanced in color and in weight. Since the grand piano is probably the heaviest piece of furniture in your room, it will have to be balanced with something that will hold down the opposite side of the room: a tall secretary or a seating arrangement of a substantial sofa and chairs surrounding a coffee table. To place the piano: Begin by measuring the room accurately, including the doorways and windows. Then, using a scale of 1/4 inch to the foot, which is one graph square, draw the outline of your room on paper. Measure your furniture. Then using the same scale of 1/4 inch to the foot, draw the shapes on paper and cut them out (it also helps to color the pieces). You can then work out the best furniture arrangement on your paper scale, moving the pieces around with your fingers. Place the piano first; it should be in a corner of the room with the straight side lined up to parallel the wall, the graceful curved side should face out, the keyboard should be away from the eye. Then arrange the rest of your furniture, remembering to balance weight and color and allowing for traffic patterns.

ETHAN ALLEN GALLERIES

Check list below
for the Ethan Allen Gallery
nearest you

CALIFORNIA

Los Angeles (Santa Ana) Georgetown Manor
Los Angeles (Torrance) Carriage House
Los Angeles Steins Furniture
Mountain View Carriage House
Sacramento Kincaid Home
Furnishings
San Bernardino Red Coach
Maple Shop
Santa Rosa Yeager's Carriage House
Whittier Hinshaw's

COLORADO

Boulder Homestead House, Inc.
Denver Homestead House, Inc.
Denver (Lakewood) Homestead House, Inc.
Ft. Collins Bowling Furn. Co.
Littleton Homestead House, Inc.

IOWA

Burlington Carriage House
Cedar Rapids Carriage House
Des Moines Carriage House
Ft. Dodge Carriage House
Ottumwa Carriage House Gallery
Waterloo Carriage House

KANSAS

Hutchinson Adams-Parker
Furniture, Inc.
Kansas City Falconer Furniture Co.
Prairie Village Pilgrim House
Topeka Moore's Furniture, Inc.

MINNESOTA

Minneapolis Concord House
Moorhead. Simon's Home Furnishings
St. Paul Swenson's Carriage House

MISSOURI

Columbia Mulkey's Carriage House
Jefferson City Mulkey & Marshall
Kansas City Pilgrim House East
Moberly Mulkey's Home Furnishings
St. Louis Carafiol's Colonial Manor
St. Louis (Bridgeton) Carafiol's
St. Louis (Lemay) Carafiol's

MONTANA

Great Falls Carriage House

NEBRASKA

Grand Island Swan's Furniture
Lincoln Davidson's American
Showcase
Omaha Carriage House
Omaha Davidson's Furniture
Showcase

OKLAHOMA

Ada Perry & McGee
Oklahoma City Village Carriage
House
Shawnee Perry & McGee
Tulsa Rich's of Tulsa

OREGON

Portland Georgetown Manor

UTAH

Salt Lake City Carriage House

WASHINGTON

Dishman Tradition House, Inc.
Everett Bon Marche
Oak Harbor Haddon Furniture
Richland Bon Marche
Seattle Bon Marche
Spokane Bon Marche
Spokane Tradition House, Inc.
Tacoma Bon Marche
Tacoma Ralph Johnson's
Carriage House
Tukwila Bon Marche
Yakima Bon Marche

For a Gallery near you,
if not listed above, write
Ethan Allen, Dept. HG-1071
Box 288, Murray Hill Station,
New York, New York 10016



Old Tavern Bonnet Top Secretary



Contemporary Still Life Serigraph

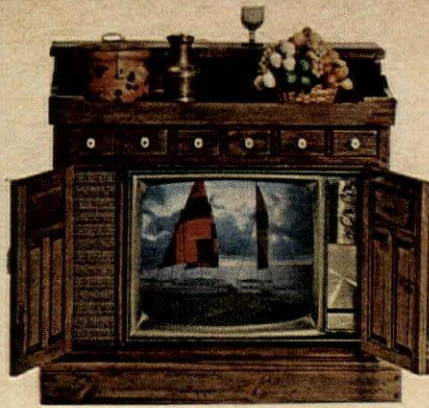

Old Tavern Dry Sink Color TV



17th Century Style Bow Back Windsor Chair

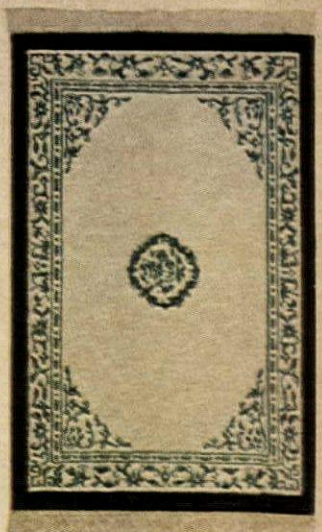

Peking Ming Oriental Design Rug



Hand Painted Tole Tithing Tray

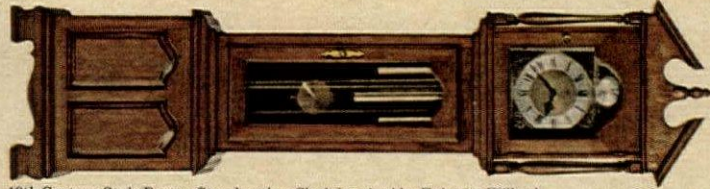

19th Century Style Boston Grandmother Clock Inspired by Ephraim Willard



18th Century Style Copper and Brass Scuttle and Kettle



Hand Decorated Ladder Back Chair



18th Century Style Breakfront With Crown Glass China



Clipper Ship "Independence" Painting



19th Century Style British Campaign Chest



18th Century Style Bonnet Top Highboy



Lusterware Dinner Plate

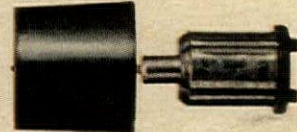

Imported Pewter Tea Caddy Lamp



Serpentine Bow Front Chest

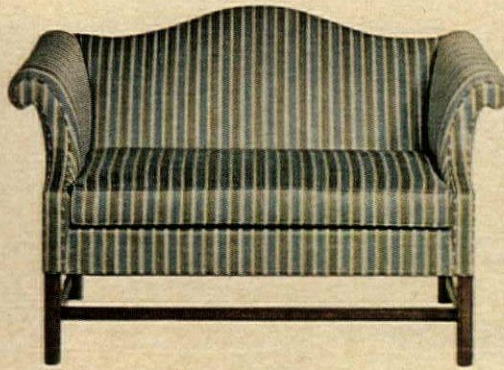

18th Century Style Chippendale Loveseat



18th Century Style Queen Anne Wing Chair



Classic Manor Bonnet Top Curio Cabinet



We can help you put all the pieces together.

Decorating a home or a room is like putting together a puzzle.

You have to know what goes where. Does that go with this? Or that? Does this go here? Or there?

And if you do find it a little puzzling, we at Ethan Allen can offer you some professional help.

At our galleries, we have people who are skilled home planners instead of just furniture salesmen. So we can show you what goes with what. And what doesn't go with what.

What's more, all our furniture and accessories are found in completely furnished American Traditional room settings. So you can get an idea of how to put the pieces together by seeing how we put them together.

You'll see over two-hundred years of classic designs including Royal Charter in the English Tudor tradition. Mellow Antiqued Pine and Heirloom from the cherished heritage of New England. And Classic Manor and Georgian Court which offer 18th Century beauty that's just as beautiful today.

But putting it all together means more than just furniture.

It also means rugs, draperies, wall coverings, lamps, pictures, clocks and almost any accessory you can imagine. All of which have been carefully selected and coordinated to work with one another.

In short, what we've done is brought together under one roof something you may not find under

a dozen others. The best designs in American Traditional furniture and accessories. So you can best express your individual taste.

Come into your nearest Ethan Allen Gallery soon. It could be the first step in getting all the pieces to fall into place.

And while you're there pick up the Ethan Allen Treasury. A 358-page book chock full of all kinds of decorating ideas. It's a \$5.00 value that's yours free for the asking.

For the Ethan Allen Gallery nearest you, see the listing on the opposite page.

Ethan Allen Galleries
We care about your home...almost as much as you do.

Belgian
crystal with
ogee edge,
floating on
antiqued brass.

"One nice
thing after
another"
from

*Knapp
& Subbs*



DISTINGUISHED DISTRIBUTORS OF FINE FURNITURE THROUGH YOUR DESIGNER, FURNITURE RETAILER OR ARCHITECT. ASK TO BE INTRODUCED IN: ATLANTA, CHICAGO, CLEVELAND, GRAND RAPIDS, LOS ANGELES, MIAMI, NEW YORK, SAN FRANCISCO.

QUESTIONS & ANSWERS

ANTIQUES

BY LOUISE ADE BOGER



This tureen with a tobacco leaf design will be on display at our antiques show. Can you give me its approximate date and tell me something about the pattern?

B.A.R.—Atlanta, Ga.

TOBACCO LEAF TUREEN

The Tobacco Leaf pattern is an overall design chiefly of tobacco leaves and flowers in combinations of shades in brown, blue, green, pink, rust, and gold. There are about eight or ten variations of this popular pattern in various shades. Quite often, as in your tureen, the design includes a pair of interlinked circles and a larger circle containing four flowers. Your Oriental Lowestoft piece probably dates about 1780. This type of ware is also called Chinese Export porcelain because it was made in China for export only and is a true porcelain.

EDITOR'S NOTE: *The High Museum Antiques Show in Atlanta, Ga. will be at the Merchandise Mart, Peachtree Center, October 6-9.*



CHARLES II TABLE

We inherited this table and were told it is a valuable antique. How old is it?

L.E.S.G.—South Orange, N.J.

Judging from the snapshot, your gate-leg table with baluster turned supports belongs to the Charles II era, and was made in England around 1660-1685.



NINETEENTH-CENTURY VASES

Our Rusk County Heritage Association was recently presented with these two blue vases, but we have no information about them and would be very grateful for whatever you can tell us about their place and date of origin.

E.H.L.—Henderson, Tex.

Your blue glass vases with white enameled decoration appear to be of mid-nineteenth-century Continental manufacture. The light and graceful, almost lace-like, decoration shows Grecian influence and is the work of a talented artisan.

Continued on page 74

What does one little black medallion have to do with an 18-color carpet?

Look closely. This black medallion means you're about to invest your money wisely. It guarantees that the carpet that's glowing before you is a genuine India hand-made Chindia.* No fooling and no faking. Just pure woolen yarns that proclaim their vibrant 18 colors in the truest chrome dyes. It's hand woven, hand-carved... and shouldn't it be luxuriating on your floors?



Chindia, medallion and all, can be seen at a fine store near you. So can Khalabar* and Bengali,* each bearing its own proud medallion. Another worthy investment... our full-color illustrated book of inimitable India hand-woven carpets... send 50¢ to **PANDE, CAMERON and COMPANY** of New York, 295 Fifth Avenue, New York, N.Y. 10016.



*Reg. U.S. Pat. Off.

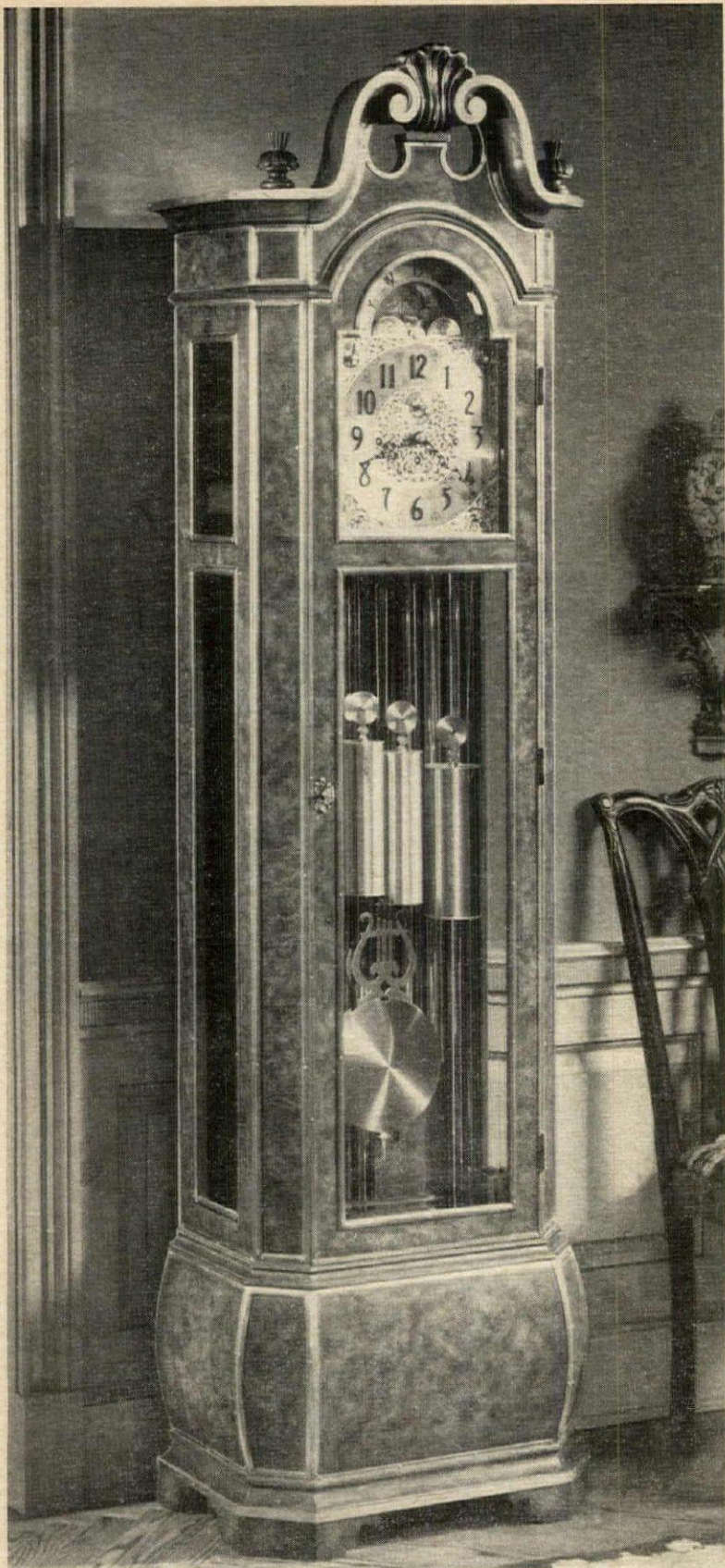

"The Clock," \$3400.

We make the most of time.

Ten companies in America make grandfather clock cases. Only Herschede makes grandfather clocks. Because only we make the movement that makes the case a clock. For a color brochure of America's finest clocks (with prices) write to Herschede Hall Clock Co., Starkville, Miss. 39759.

Herschede



Gold Medal Winning Clocks Since 1885

MING DYNASTY PLATE

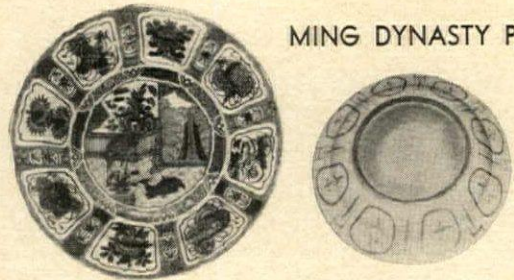

My Chinese porcelain dish is supposed to be from the Ming dynasty. Could you tell me if this is correct? J.A.—Newark, N.J.

Judging by your snapshots, your porcelain dish, painted in underglaze blue, was made in China during the Chia Ching reign of the Ming Dynasty (1522-1566).

PANETIÈRE

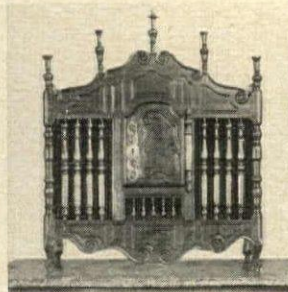

I bought this piece in an antique shop. They thought it was some kind of cupboard. Can you identify it? L.B.C.—Paoli, Pa.

You have a hanging cupboard, a charming piece of French Provincial furniture. It is a bread cupboard, called in French a *panetière*. It is in the Louis XV style, but since these cupboards have retained their popularity and are still being skillfully copied, it would be necessary to have your *panetière* examined to ascertain if it was made in the eighteenth century.

AUSTRIAN POTTERY

I traced the markings from the bottom of this piece of pottery for you. Can you tell me where it came from?

M.B.A.—Wichita, Kans.

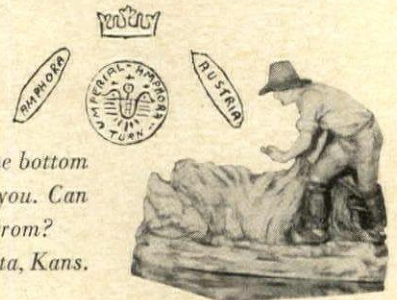

Your pottery, depicting a young farm boy scything grain and a hen picking up seeds was made at the Amphora Porcelain Manufactory at Turn, near Teplitz, Austria. Riessner and Kessel started this firm in 1892 and porcelain figures were its chief concern.

DUTCH MINIATURE CHAIR



I have a sterling silver miniature chair, 2 inches high. The marks on its back are, from the top, S.B.I., F, crown, lion, and, I think, an L. On the bottom is a sailing boat, 930, and a sign of a bell. What does it all mean? How old is it and where was it made? E.L.—Atlantic City, N.J.

Your miniature silver chair is Dutch in origin. The marks under the seat are more or less meaningless. 930 is probably the standard of silver. The full set of Sheffield marks on the front of the back panel was put on at the time the chair entered England, its foreign origin being shown by the F. The date letter is not entirely legible. It may be C (1895-96) or R (1909-10). The mark centered in the crest rail is probably a Dutch control mark.



any red blooded American would like a pioneer collection



Temple-Stuart

BALDWINVILLE, MASSACHUSETTS 01436

For colorful booklet showing complete collection of Pioneer Treasury furniture and name of nearest dealer, send name, address and 10¢ to HG-101.

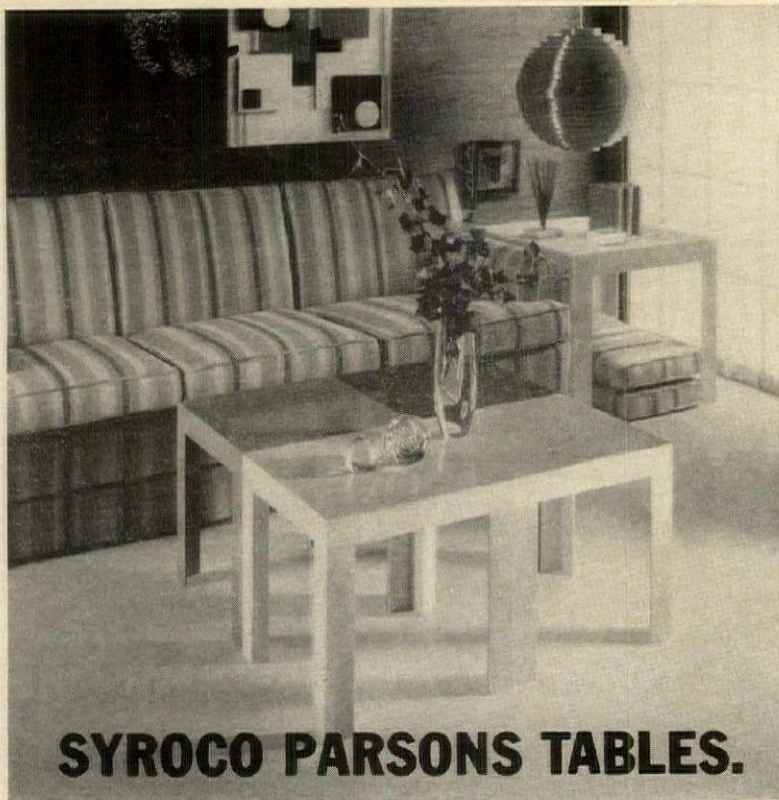

SYROCO PARSONS TABLES.

They make your home look young.

Decorating sensation of the year, these little beauties are terrific indoors or out. As cocktail tables, coffee tables, bunching tables, end tables, even as extra seating. Chip-proof ABS plastic (just like your telephone). Gorgeous House & Garden colors: Tangerine, Sun Yellow, Parrot Green, plus Jet Black and White White. 3 sizes: 16" x 16" x 16", 24" x 24" x 16", 24" x 24" x 21". About \$15 to \$30 at furniture, gift and department stores.

For "All About Walls", famous 180-page book that shows how to make your home exciting with wall accessories, send \$1 to Syroco, Dept. HG, Syracuse, N.Y.

SYROCO
A DIVISION OF DART INDUSTRIES INC.
SYRACUSE, N.Y. 13201

DEBUT '72



wings to stop the winds

The "wings" of the wing chair were designed to keep out drafts, hold in the warmth of a blazing fireplace! We kept every charming true-to-tradition detail... a sweep of Queen Anne curves from its high arched back to its solid cherry stretcher base! Pennsylvania House, Dept. HG1071, Lewisburg, Pa.

DEBUT '72

Pennsylvania House



A GARDENER SPEAKS HIS MIND

A walk with perennials

PART ONE

By William B. Harris

"There is nothing in this life pleasanter than to wander through woods, plains, garlanded and adorned with plants of various sorts, and most elegant to boot, and to gaze intently on them. But it increases that pleasure not a little more if there be added an acquaintance with the virtues and powers of these same plants." Those lines were written by Leonhart Fuchs in *De Historia Stirpium*, an herbal published in 1542, and were used recently by Peter Coats as an introduction to his excellent work, *Flowers in History*, which Viking published in 1970. We shall wander through no woods or plains, as pleasant as that might be in these crisp, fall days. Our walk will be restricted to the garden, but only that part of it devoted to perennial plants that do not get their start in life from bulbs. Most of those chosen are rugged, hardy things, suited to climates that drop to minus 20° Fahrenheit. I've noticed that gardeners who work with perennials tend to be conservative—in the sense that they concentrate on the genera they are most successful in growing. It seems to follow that any pleasure you get from this walk with perennials will come in terms of at least knowing a bit about many other plants, enough perhaps to help you decide to reach out for some of them. I have ticked off places of origin in most instances, added some phonetics to help pronounce those classical names that many gardeners find beastly (they can take heart from the fact that even Ruskin thought Linnaeus's nomenclature repulsive), noted common names, given color, and height range. And if culture requires something more than that delicious combination of sun, a good sharp garden loam, and water, I have added that too. In Zone 4 (the minus 20° regions) it is too late to plant most of these unless you have a ready source,

but in the warmer parts of Zone 5 (minus 10°) and farther south, planting this late seems safe. Of course, newly planted perennials, like nearly all other established perennials, need a protective covering to do well. Let's walk.

ACHILLEA (ack-ill-lee'a) **Yarrow.** These valuable garden plants from the North Temperate Zone are widely grown for the masses of flowers they bear throughout most of the summer. The foliage is attractive and fern-like. Plants grow well in dry, exposed places. They are not fussy about soil, but do best in a good garden loam. There are several excellent varieties whose colors range from shades of yellow or rosy-red to white, some 3 feet, others less than half that tall. Use in mid-border. The hybrid, *Coronation Gold*, produces one of the easiest flowers to dry—and one of the best. Plant in spring or fall.

ACONITUM (ack-ko-knee'tum) **Monkshood.** This genus of 100 species from the North Temperate Zone has many excellent fall-flowering varieties that help keep the perennial border in bloom before chrysanthemums come into flower. Blooms are far more interesting in shape than their common name suggests. Almost all varieties are extremely hardy and because they are tall make excellent back-of-border plants. Blue to purple is their predominant color, but some are yellow, others white. They thrive in good soils, and where shade is not too heavy they do as well as in a sunny location. They like moisture, but refuse to grow where the ground floods for periods or is too wet, and they strongly dislike being moved. The genus is not widely used undoubtedly because the plants are known to be very poisonous if eaten—they are not to the touch. Note: If you are thrown off by this remember to plant no delphinium, mountain

Continued on page 80

This is a new invention. We call it a stove.

The Corning range is more than a stove. It's the first total-cooking concept ever developed. You cook with precisely controlled heat, on a beautifully smooth glass-ceramic surface, in specially designed cookware. This perfectly matched system helps take the guesswork out of cooking and can even make you a better cook.

Precise, uniform heat. Both the Counterange™ electric range and Corning's built-in electric cooktop, the Counter That Cooks™ (below left), have a completely new kind of heating element, designed to deliver heat evenly and predictably across each cooking area. There are no hot spots. All four cooking areas are thermostatically controlled, just like your oven, which means you can set the dial and know that you'll never go above the desired heat setting. A simmer stays at a simmer. And you can always tell which cooking areas are on because each one has its own indicator light, and the sunburst areas turn yellow as they heat up.

What's so special about the self-cleaning oven?

We didn't invent the pyrolytic self-cleaning oven, but we think ours is particularly good. We moved the locking lever off the front of the range, out of reach of children. To clean, you simply turn two knobs. It's completely safe, too, because the oven door double-locks automatically. And cleaning costs about 12¢. But best of all, the oven is extra roomy—you can actually put three 8" cake pans on one shelf.

It looks clean because it is clean.

The ugly part of cooking is cleaning up. No one will argue that point. But when our cooking surface gets dirty you can see it... and restore it to its original beauty every time. Basically, it's just like cleaning your countertop. And you can quickly remove even stubborn cooked-on spots with a damp paper towel, our special silicone Cleaner-Conditioner and a little rubbing.

What about pots and pans? Whatever you use, it has to be flat-bottomed. That's why we designed a special kind of cookware for Counterspace Cooking called Cookmates® Cookware. They're the ultimate answer to that complete and precise control over your cooking we were talking about earlier. A Cookmates starter set is included with your new unit. As far as your other pots and pans are concerned, the best way to tell if they'll work is to try them. In any case, we think you'll like our cookware so well you'll eventually want to get a complete set. We have an assortment of fifteen shapes. Cookmates Cookware go from freezer to range to table beautifully, and because of the detachable handle, they'll fit into the dishwasher, too.

Think of the extra counter space.

When you're not cooking, the whole surface is there for you to use. In fact, you can use any area you're not cooking on because the heat stays where it's supposed to.



A word about installation and service. The Counterange uses standard electrical hookup and comes in two 30" wide models: free-standing and slip-in. The Counter That Cooks built-in cooktop measures 32¼" x 21½" overall. It's only 3⅞" deep so you can still have storage space under your cooktop. At Corning we stand behind every appliance we sell. The Corning Promise covers the replacement of parts and labor for one year and during the second and third years, critical parts will be replaced free—the only cost to the owner being labor. And for your convenience Authorized Corning Service Agencies are located throughout the country.

If you have any questions about Counterspace Cooking, stop in to see your local Corning appliance dealer. He's listed in the Yellow Pages under "Ranges." Or, write for complete brochure.

CORNING



5

4

3

2

1

This is the house that Herb rebuilt...

(with a little help from U.S. Plywood).

Meet Herb and Eileen Hebert and the house they rebuilt in Meriden, Connecticut.

When the Heberts and baby Jennifer first moved in three years ago, there was more than enough room for the three of them. But then along came Suzanne, now aged 2, Jessica, aged 1, and Murphy, aged 9½ months (he's the one with the tail, at left).

And a problem: how to fit five people and a dog into a house built for four? The Heberts felt stuck. And with a budget as tight as theirs, building or buying a new house was out of the question.

The only solution was to rebuild and remodel their old one. Herb would tackle much of the work alone. With a little help (help?) from Murphy and the girls, and quite a lot of help from U.S. Plywood.

That's where we came in. We talked with the Heberts. Listened to them. And for almost every improvement they had in mind, were able to suggest a U.S. Plywood product to do the job. In many cases, several.

First order of the day was adding more space. A new family room with a sundeck on top? We were able to supply them with U.S. Plywood products to help take it from the floor up.

Next was making better use of the space they already had. The

Heberts agreed they wanted three things from the rooms of their home. Good looks. Versatility. And easy maintenance. It didn't take much to convince them that our Weldwood® prefinished paneling was the answer. The only thing they couldn't agree on was which of the dozens of Weldwood panels to choose from. Eileen wanted elegance and light. Herb wanted a dark wood grain.

Eileen won, but only by promising to help with the installation. The final touch?

A miraculous face-lift to the old stucco exterior.

And we had 29 different styles of siding to show them.

For further adventures of the Heberts and the house they rebuilt, watch future issues of this magazine. Meanwhile, couldn't your house use a face-lift? All it takes is an average handyman's talent — like Herb's — and a little help from U.S. Plywood.

Your local lumber or building supply dealer has the ideas (and the siding, paneling, doors, underlayment, decking and finishes) to get you off to a good start. Look him up. Or look up your Weldwood Headquarters Dealer in the Yellow Pages under Plywood.

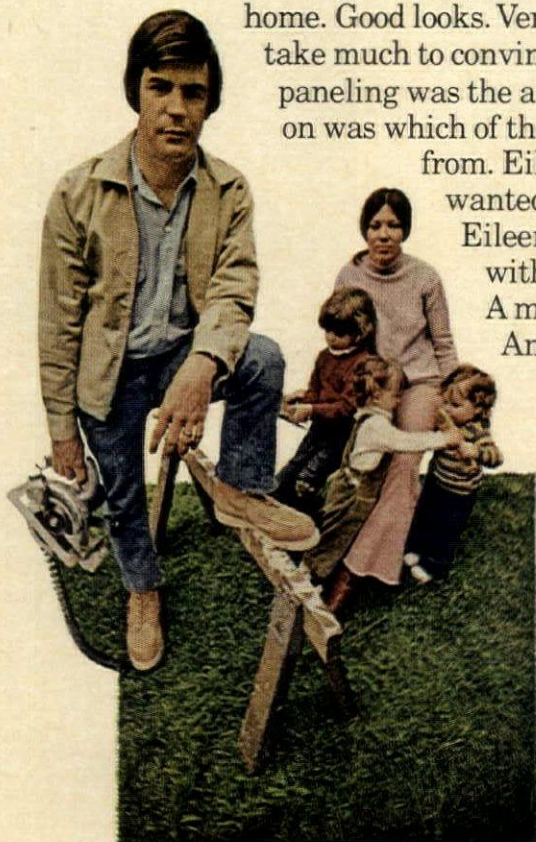

Photo shows Herb's house before these changes:

- 1) Family-room addition... sheathing, subflooring, bi-fold doors, Weldwood *Craftsman*® paneling... all by U.S. Plywood.
- 2) New sundeck atop addition... with Grid Pattern Permaply® decking.
- 3) Front entranceway relocated.
- 4) Remodeled living room... with Weldwood *Deluxe* paneling.
- 5) Entire exterior covered with Roughtex® board and batten siding.



U.S. Plywood

A Division of U.S. Plywood-Champion Papers Inc.

For the new family-room, Eileen wanted good looks that would stand the test of time.

Rebuild ■■■ She's almost settled on Weldwood's Craftsman® Rustic Hickory.

rest Japanese. They are especially hardy, but few have garden value. *A. Tabernaemontana*, the best variety I know, does best in ordinary soil in part shade; it likes moisture and makes an excellent plant for the edge of woodland, in a wild garden, or for a similar spot in a shrub border. Dense clusters of soft blue flowers show in May-June. It can be propagated easily by division in very early spring, which is the only time to plant or move it.

ANCHUSA (an-choo'sa) **Alkanet.** There are about forty species of these charming early bloomers from the Old World that belong to the forget-me-not order and are grown widely for their showy flowers. Those in commerce are mostly blues: heights vary considerably. Anchusa like a deep, well-drained soil, not too heavy, and do best in full sun. Plant only in the spring.

ANEMONE (a-nem'owe-nee) **Windflower.** This most charming group of perennials is widely distributed over the temperate regions in many forms. The genus is a member of the buttercup family. The fibrous-rooted forms generally do well in an ordinary

garden soil, but rich sandy loam suits them well and woodland soil is even better. The principal one, which has had its name changed to *Pulsatilla vulgaris*, is very hardy and grows, with great charm, from 6 to 10 inches tall. It comes in red, white, and purple. Spring planting is best.

ANTHEMIS (an'them-is) **Golden Marguerite.** Few species in this large Eurasian genus have ornamental value, except *A. tinctoria*, and it is about as well-known and as widely grown as can be. It is not the least fussy about anything. It can be planted in spring or fall.

AQUILEGIA (ack-wi-lee'jee-a) **Columbine.** Lacy greens and dancing blooms characterize this lovely border plant of over forty species found in high mountains over a broad range of the earth. There are also several strains of hybrids. Those with long-spurs are my favorites. They make excellent cut flowers and bloom over a period of four to six weeks. Varieties grow 20 to 30 inches high and should be planted toward the middle of the perennial border and in the rock garden. Mark the fact that they seed pro-

PERENNIALS *continued from page 76*

laurel, rhododendron, Christmas rose, foxglove, belladonna, and many other plants, shrubs, and bulbs, all of which are equally poisonous—and rip up jimsonweed, its parts are all deadly. Varieties can be planted in the spring or fall.

ADENOPHORA (a-den-off'ora) **Ladybell.** About twenty species of perennials from eastern Asia make up this genus, which, unless you are a botanist, is not easy to tell before bloom from campanula. The flowers, however, are drooping and in racemes. The varieties are hardy and generally do well in rich soils that are not too dry. The few in use (two, really) are grown for their pleasant blue flowers. Warm and sunny describes the best location. Adenophora is difficult to move, so plant where you want them to stay. Increase stock by cuttings; dividing the plant is nearly impossible. Plant in spring or fall.

AJUGA (a-joo'gah) **Bugle.** There are many splendid rockery plants in this European genus that show a wide range of color

on perky spikes 6 to 8 inches high. Ajuga is also one of the best ground covers for locations in sun or light shade. It spreads quickly and when established mats so heavily that weeds find it hard to grow. For quick covers place plants 6 inches apart. Ajuga is evergreen in mild climates and practically indestructible. May be planted spring or fall.

ALYSSUM (al-iss'sum) **Madwort.** Europe and Asia have given us the many useful shades-of-yellow species that make up this genus. Planted in ordinary, well-drained soil in full sun they are most rewarding. We suggest using them in groups in the perennial border, the rock garden, or as edging plants. *Saxatile* (called Basket-of-Gold) and *citrinum* are striking when planted in baskets or patio containers. Their flowers show in profusion in early spring on 12- to 15-inch stems. Plant them only in the spring.

AMSONIA (am-sown'ee-uh). There are only seven species in this genus—two American, the

...renew Unless, of course, she chooses Weldwood's Hawthorne® Avocado. Easy on the eyes. Easy on the pocketbook. Wipes clean with a damp cloth.

Both Heberts agree Weldwood's Vinylgard[®] Pecan would survive beautifully in the children's rooms. After all, its tough vinyl surface will stand up to

scratches, spills, dents and tooth marks.

...restore

digiously and that the seedlings, although they can be used, seem more bother than they are worth. Crowns of old plants sometimes get too high and may winterkill—to fix, dig up and plant the crown at the surface, where it first started. Aquilegia can be planted spring or fall.

ARTEMISIA (are-ti-miz'ee-a) **The Wormwoods.** A large genus of plants that are not grown for flowers. Their attraction is the silvery white, silky covering of down on the shoots and leaves. They are very useful as foil plants in the border and rockery and excellent for contrast in flower arrangements. Culture is easy: Give them a well-drained soil in a sunny position and they will be happy. Plant only in the spring.

ASCLEPIAS (as-klee'pe-as) **Butterfly weed. Milkweed.** There are over 150 species in this large group from the Western Hemisphere and Africa. Few are of interest in the garden and many are not hardy. *A. tuberosa*, an American, which throws bright orange flowers from July to September, is the best bet. It can be planted spring or fall.

ASPERULA (as-per'u-la) **Madder.** A genus of about eighty species of herbs (sometimes small shrubs) that are native to Europe, Asia, and Australia, but few have garden value. Flowers appear in terminal clusters, and although individual blooms are small, the clusters produce an excellent show. Most widely grown is *A. odorata*, Sweet Woodruff, whose dried foliage is very fragrant. *Asperula* grow well in almost any garden soil, and may be planted spring or fall.

ASTER (as-ter) **Michaelmas Daisies.** Strange that American gardeners show so little interest in this lovely flower. Perhaps this is because the wild form is a weed in much of the country. The new hybrids, nearly all developed in England, are very popular in Europe. They grow in any soil and stand up under the toughest treatment. All they require is full sun and lots of water. There are scores of varieties. Some grow in dwarf clusters, others go to 4 feet. Colors? Very broad. Asters bloom in August and September, so for this reason alone they are important plants

in any herbaceous border. Culture is similar to that of chrysanthemums insofar as separation and replanting are concerned. Dig them in earliest spring, divide and replant the vigorous outside growth, discard the old center. Asters may be pinched back to keep them from growing too tall, otherwise many varieties will have to be staked. They should be planted in the spring.

ASTILBE (as-til'bee) **Spiraea.** The best of these hardworking, beautiful border plants come from China and Japan. They throw pleasant flowers in long panicles or spikes in June and July, then bush out with decorative foliage. Astilbe grows practically anywhere in full sun, but does far better in light shade, for the color doesn't burn out and the blooms last longer. It also likes a damp location but is not the least fussy about soils. Use astilbe in bold groups in the perennial border or mass in shady locations for ground cover. Propagate by division. Astilbe is tough and can be planted spring or fall.

BAPTISIA (bap-tease'ee-a) **False Indigo.** This very useful

North American perennial (there are about twenty-five species) adapts itself to most soil conditions, and, although it tolerates full sunlight, it appreciates a bit of shade during the day. Its root system is extremely tight and spreading. Fact is, once established, baptisia can hardly be pried out of the ground and their vigorous spreading habit makes them weedy. The pea-like blooms are on 10- to 12-inch racemes; seed pods are valuable to birds that stay around all winter. They are rugged plants that may be moved in spring or fall.

BELAMCANDA (bell-am-can'-da) **Blackberry Lily or Leopard Flower.** A genus with a single species, *chinensis*, native to China and Japan, which is grown practically everywhere. Flowers are apricot-orange with black spots on stems 2 to 4 feet high. It is easily propagated by division in the spring, the only time it should be planted.

BERGENIA (ber-gen'ee-uh). An Asiatic native having twelve perennial species but only two, *cordifolia* and *crassifolia*, are hardy. They are cultivated for

Continued on the next page

...remodel

with a little help
from U.S. Plywood.

For their "new" kitchen, the Heberts are leaning toward Weldwood's Breckenridge[™] Surf.™ These color-toned panels have the look (and feel) of authentic weathered barnsiding.

WELDWOOD[®] PANELING BY

 **U.S. Plywood**
A Division of U.S. Plywood-Champion Papers, Inc.

their ornamental foliage, although the flowers are attractive. They need lime, gritty or sandy soils, and protection from the noonday sun. They grow in thick rosettes of fleshy leaves; the flower stems pop up from the base and provide panicles of bloom. Unlike many other Alpines they do not overrun other plants, another highly desirable characteristic. Plant in spring only.

CAMPANULA (kam-pan'you-la) **Bellflower.** A fine group of garden plants (over 250 species) native to eastern and southern Europe, the Alps, and Asia Minor. Varieties range from dwarf to 3 feet tall and look superb in the perennial border or rock garden. Colors are predominantly blue and white. Some bloom continuously from June to October. Culture is not difficult, as they need only a moderately rich, well drained soil. Be sure to give them protection each winter and divide half the stock every second or third year to keep it vigorous. Plant only in the springtime.

CHRYSANTHEMUM (kri-

san'thu-mum). There are over 150 species of this most valuable plant, which ranges the temperate and subtropical lands of the world. The Chinese and Japanese have cultivated them for over 3,000 years. The value of chrysanthemums in the garden is that they burst into color sensationally in the fall, the last of the flowering perennials. The choice of color and form is broad. Many gardeners buy mums in bloom in the fall, not knowing, we suppose, that fall-planted mums are not likely to winter well. It is easier to work with new stock in the spring. But this doesn't mean that you should resist good-looking mums at roadside in September. The pretty things will sparkle in an otherwise drab garden, bunches of flowers can be stripped from their sides for arrangements indoors, and, if you have a cold frame, you can probably winter them successfully. Note that chrysanthemums are tender when shipped and, although hardened-off in cold frames, cannot survive sharp frost in late spring. They need protection if planted early.

Culture: Unlike most perennials, which grow from a loose crown and which can be left in the ground for several years, chrysanthemums should be dug every year in early spring and divided. After digging, discard the center of the old root system and keep only the vigorous individual outside shoots. Each should have a good piece of root attached to it. These look like very small plants, and indeed they are, but they will grow beautifully during the season—just as well as the cuttings you buy in the spring. After division, there will undoubtedly be many more plants than needed, so give them away. Shoots or cuttings will need attention at various times during the growing season, for tops must be pinched back if one is to get a compact plant covered with bloom in the fall. Keep inspecting and pinching back new growth until July 4 or a bit later. Then let them grow. Experienced gardeners have learned that "hardy" mums are not as hardy as the ads imply and winter their spring-planted mums in frames. Particularly sensitive to the hours of daylight, mums are fooled by nurserymen who force

them to bloom by artificially shortening the day with black-cloth shade. Football-season mums, if unshaded, probably would not bloom until late December. Fortunately, garden chrysanthemum varieties have been developed so that they will rush into bloom in early September, others are bred to bloom in November. This makes it possible for gardeners all over the country to get bloom before the deep frosts. Light frosts do little damage to most varieties.

CIMICIFUGA (sim-me-siff-you'ga) **Bugbane, Snakeroot.** Tall white-flowering border plants that grow in ordinary soil in sun or light shade. They have large leaves and plume-like, branching flower spikes. I know of no tall perennial more effective in mid-July. Plant in spring or fall.

How many of the foregoing perennial genera do you know well, is now the question. If you have scored 90 percent and could pronounce all the names, you naturally should move to the head of the class. We shall do more wandering in an early issue.



Weiman
makes beautiful things happen

With the Jovan Collection of Country Louis XV and XVI occasional furniture.

Quality furniture that says you know the difference. The difference that means careful attention to detail... the pride of old-world craftsmanship... the elegance of Warren Lloyd decorator-selected fabrics.

Weiman makes beautiful things happen. For you. For your home.

Write for free colorful brochure on the Debut '72 "total look decor" ideas or see your Weiman and Warren-Lloyd dealer.

WEIMAN Ramseur, North Carolina 27316

The lady has taste.

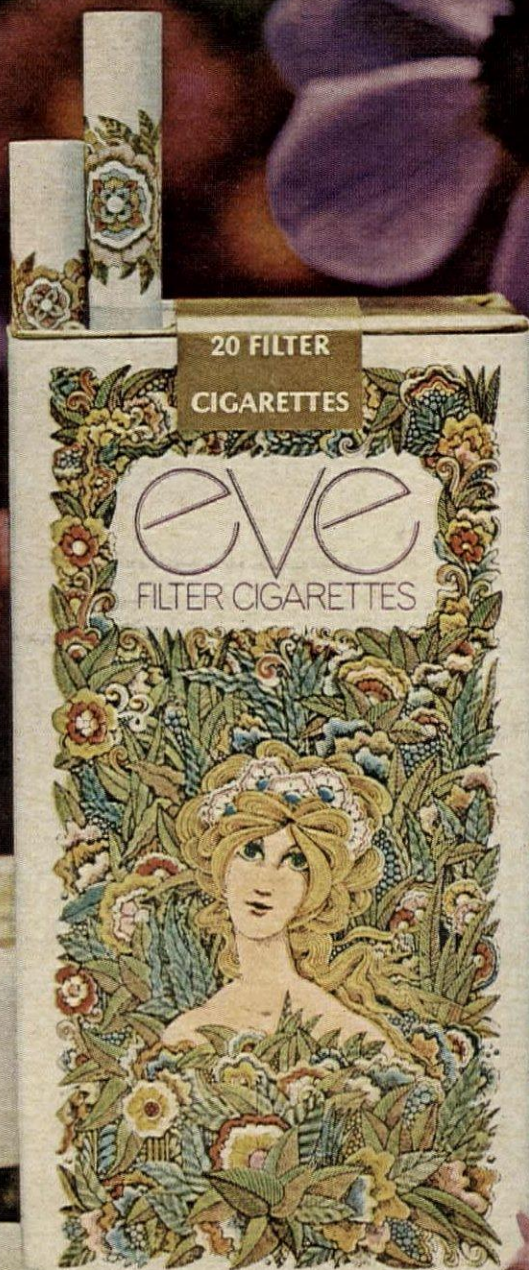

A garden of flavor just for you. That's Eve. Every cigarette is a special blend of fine tobaccos for a taste that's rich, yet gentle. Pretty pack, pretty filter, delicious taste. That's Eve. Also with menthol.

Smoke pretty.

eve

Warning: The Surgeon General Has Determined That Cigarette Smoking Is Dangerous to Your Health.

Filter: 17mg. "tar," 1.2mg. nicotine. Menthol: 18mg. "tar," 1.1mg. nicotine. av. per cigarette by FTC method.

Burlington House for bedspreads by Vera®



When we asked the artist, Vera, to create some bedspread patterns for us, she came through with flying colors. (Ten to be precise.) Plus six sensational patterns. So we took her creations and tailored them into bedspreads that look like they're custom-made. We fully quilted them with Kodol® polyester fiber fill. And used Avisco® rayon and cotton so they'd be ma-

chine washable and tumble dryable. You can even have these bedspreads automatically dry cleaned. Or take them to a regular cleaner. We also have mix and match Light-Control draperies by Vera. They're just as easy to care for. And they not only help block out light, but they also go with our bedspreads... beautifully. Ah, Vera. Ah, Burlington House. You've done it again.

BURLINGTON HOUSE
ALL THROUGH THE HOUSE.

Burlington House

A Division of Burlington Industries, 1345 Avenue of the Americas, N.Y., N.Y. 10019

To find where you can buy Burlington House bedspreads, call 800-243-6000. In Connecticut call 800-942-0655. Both calls, free.

CHANGE IT ALL AROUND?

Do it all over?

Show it all off?

CLEAR IT ALL AWAY?

HOW DO YOU
BRING YOUR ROOMS
UP TO DATE FOR

LIVING
NOW

What we love about contemporary decorating is that it's not done overnight, that it seeks out a new definition of quality, that it borrows equally from past periods and today's thinking, that the most successful rooms owe the most to your own specific knowledge of living, things you've collected, your love of family or the outdoors. This issue is a manual on how to put things together yourself, now, in your own totally unique way—a mixture of things you already have, pictures you'll group differently, old houses you've admired, old movies you've seen, trips you've taken, Indian fabrics, the Astrodome and a book on eighteenth-century furniture, the colors of an Imari plate. You'll find lots of different angles of opinion on decorating, some apparently contradictory. William Baldwin's ideas on pattern, page 8, how to mix and live with it so it comes off, give a thorough rundown on one kind of decorating. An example of one really fabulous pattern after another is the Rattazzi apartment, page 116. The dialogue between Jack Lenor Larsen and Robert Schwartz, page 100, leans more to the subtract-rather-than-add school of thought. The Lesser and Cowles apart-

ments are marvelous examples of a love of space—subtraction—worked out in a city apartment with medium-sized rooms and in a gigantic one-room floor-through. And in keeping with the idea of simplifying spaces, the terraced garden, page 112, looks like a vast Frank Stella driven into the earth.

Ideas for color schemes run from untraditional colors as the jolt for an otherwise traditional room, page 97; to a room, page 90, where the color idea is to have almost all texture and natural color—bleached woods and terra-cotta tile—as a background for handcrafts; to the living room, page 118, with blue and white plus warm peaches and apricots, a Persian rug and needlepoint chairs where the result is no scheme and lots of color. Room plans tuned to function and modern lives are the bed-living room, page 94; a two-table, two-sofa dining room filled with art, page 95; the

all-one-color, almost-no-furniture living room, page 104; or a more traditional bed-sitting room plan with a 6-panel screen behind the bed, an 8-foot sofa, and a big bedside table for eating on trays, watching a sleek TV, page 91. Window ideas run from the bareness of a painted molding framing three big windows in a garden room, page 92; to the Arabian tented look of the library-guest room, page 123; and the painted wood grillwork, page 108. There's an enormous roster of versatile furniture that can be used countless ways for very different effects, seen on pages 86-88—sort through the eleven rooms, from pages 89 to 99, to get an idea of how easy it is to use it all. There are two very good and opposite attitudes toward storage for everything—one closed, one open—on pages 104 and 108. Art for everybody means everything from a young collector's ideas on buying, page 31, his own apartment, page 102; to a dining room, page 95, where guests sit down and get a good look as opposed to passing something in the hallway.

We hope you'll put some of these ideas together for yourself. The only errors are a lack of enthusiasm and courage.

For living now

Fifty pieces of furniture and how you can decorate with them in marvelous new ways

We're taking you on a trip. We want to show you how you can walk through a furniture store in search of something new and refreshing for your house and *know* what will go with what, where, how, and why. We begin by isolating fifty pieces of furniture you can buy now, and then we show them again in rooms (you can identify each piece through its number) on the following twelve pages. Leading designers from stores across the country have decorated these rooms, and they can be seen in the stores we mention, from mid-September into October, at the time of Debut '72, the nation-wide event organized by the Home Furnishings Council to introduce 1972 designs. While each room is decorated very differently, we find a common denominator in them all. This is a clutterless, clean-cut quality, a pared-down look, a feeling of less rather than more. Why should we suddenly want to subtract rather than add? The answer is evidently this: To balance the complications of living today, we all feel a need to simplify at home.

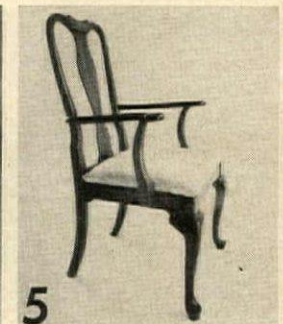

MIEHLMANN

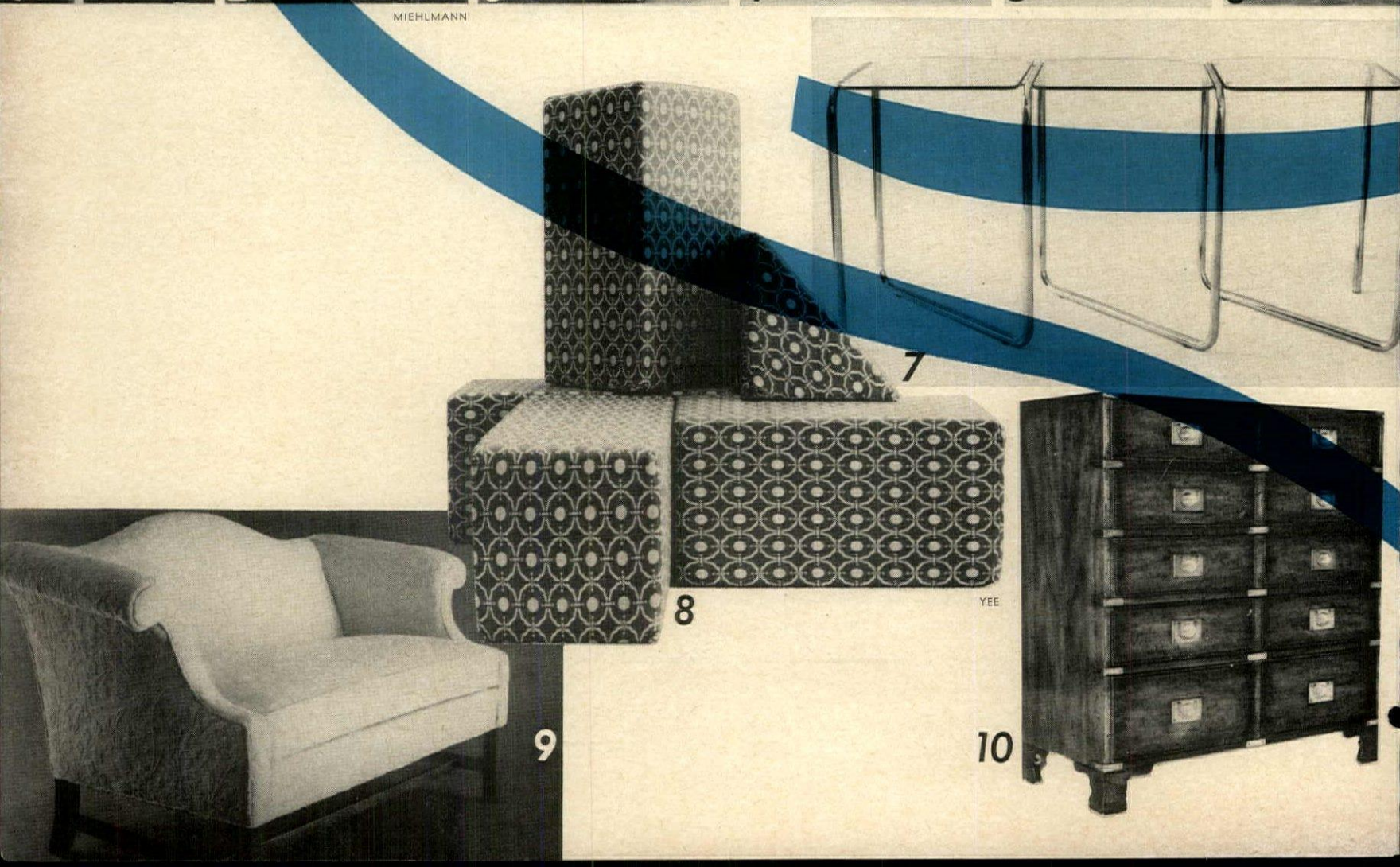



11

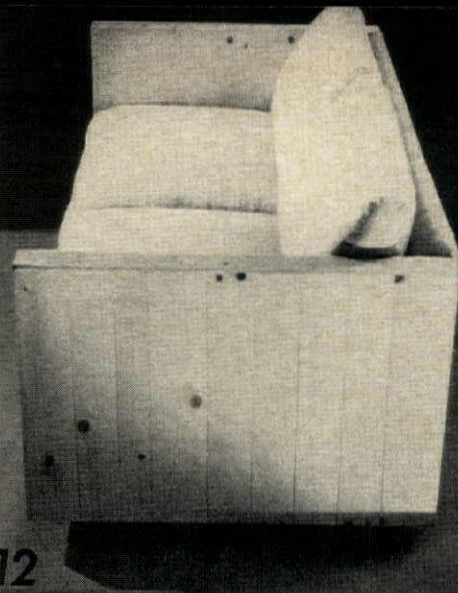

12



13

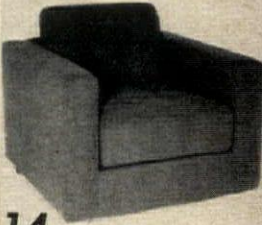

14

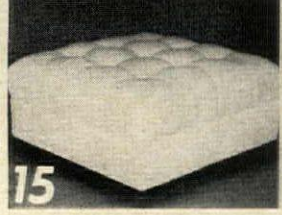

15



16



17



18



19



20



21



22

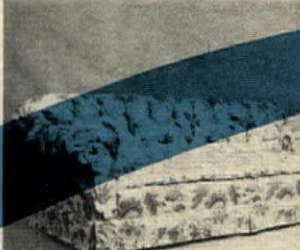

23



24



25



26



27



28

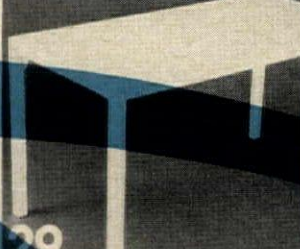

29



30



31

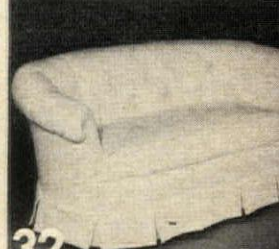

32

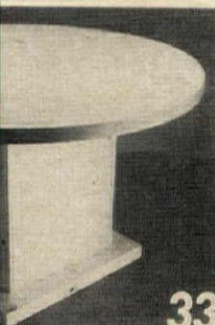

33

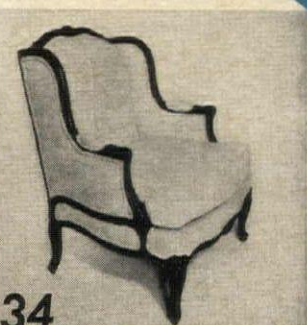

34



35

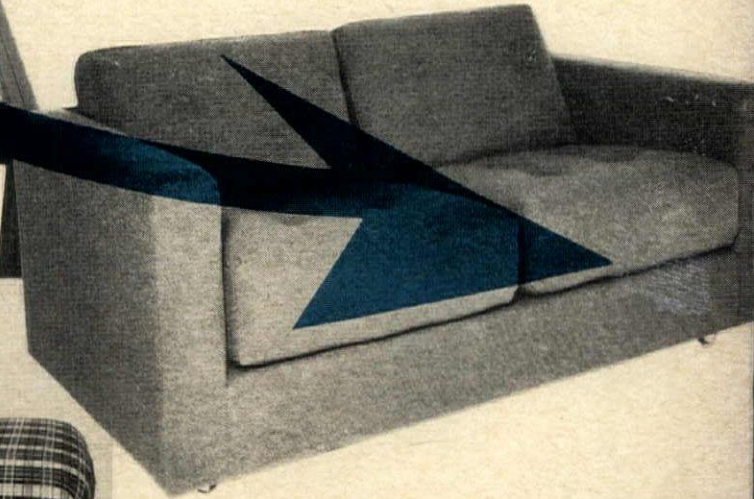

40



36



37

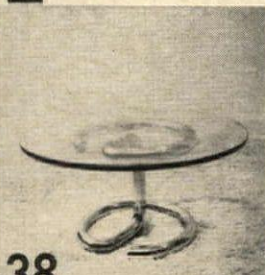

38



39

For shopping information, see page 144.

For living now

MAYR

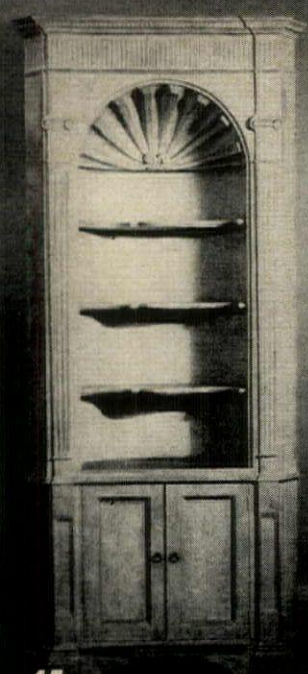

41



42

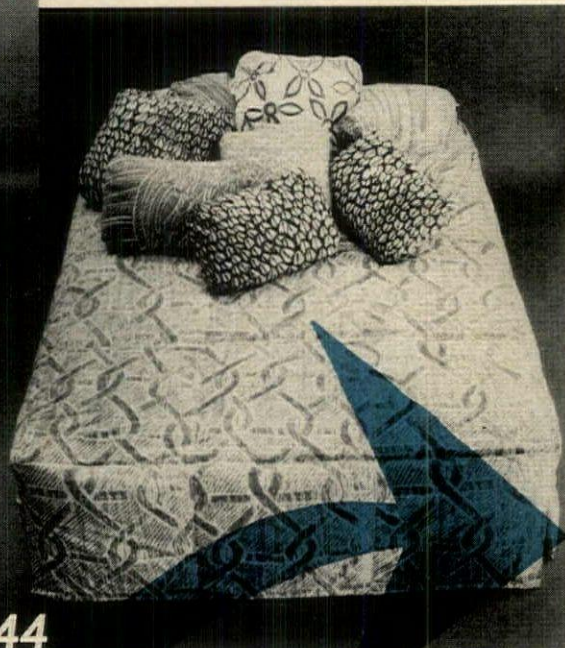

44

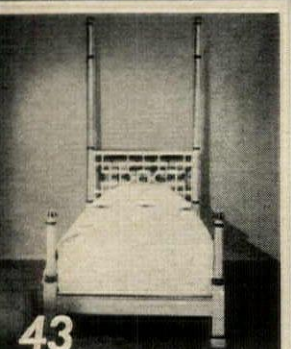

43

Great living room of put-together move-around furniture

All the seating's out in the open in this living-entertaining room, walk-aroundable and very movable, too, made of lightweight foam shapes. "Here's a forward-thinking room for people who don't like to be limited," declares the designer James Wilds of Bon Marché, Seattle. "Very adaptable, very livable." For parties, the chrome and glass tables against the wall serve as buffets and everyone sits around informally. A room of pale textures, Belgian linen on the walls, bamboo blinds, beige wool carpet, because, adds Mr. Wilds, "people, conversation, music, and art provide all the color."

In the room plan: foam blocks (8) covered with polyester knitted stretch fabric. Molded foam chairs in stretch fabric (16) and white vinyl (26). Round tables with chrome bases (42). Glass and chrome buffet tables (7). All by Founders. Carpet by Bigelow-Sanford. William Sellers sculpture from the Max Hutchinson Gallery. Harvey Quaytman painting from the Paula Cooper Gallery. Room at Bon Marché, Seattle.

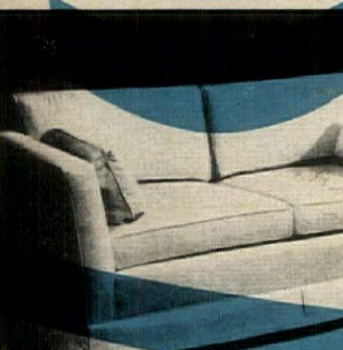

45



46



47

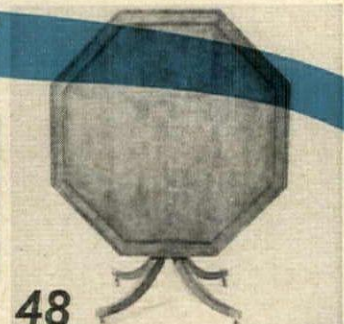

48

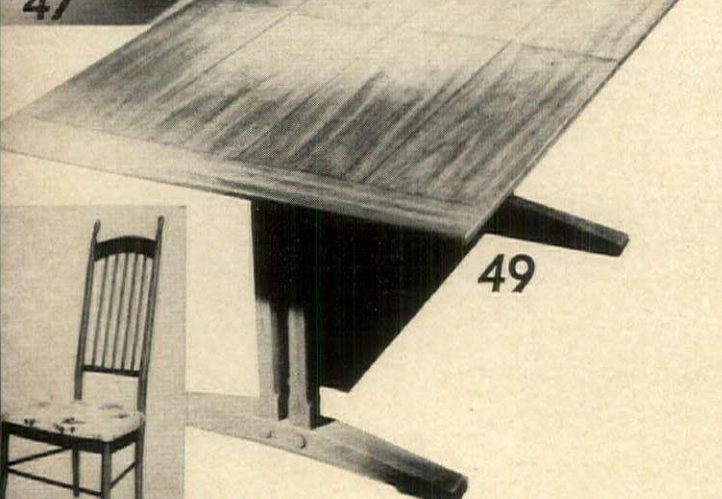

49



50

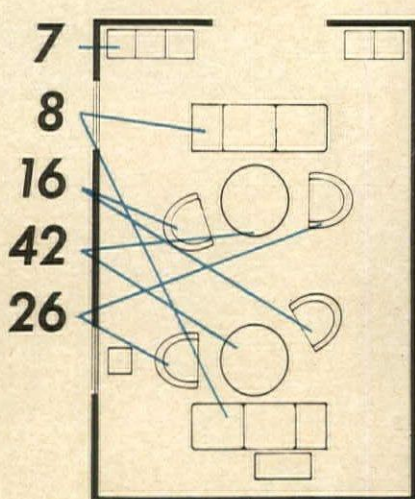

ALL PLANS BY BROTMAN

YEE

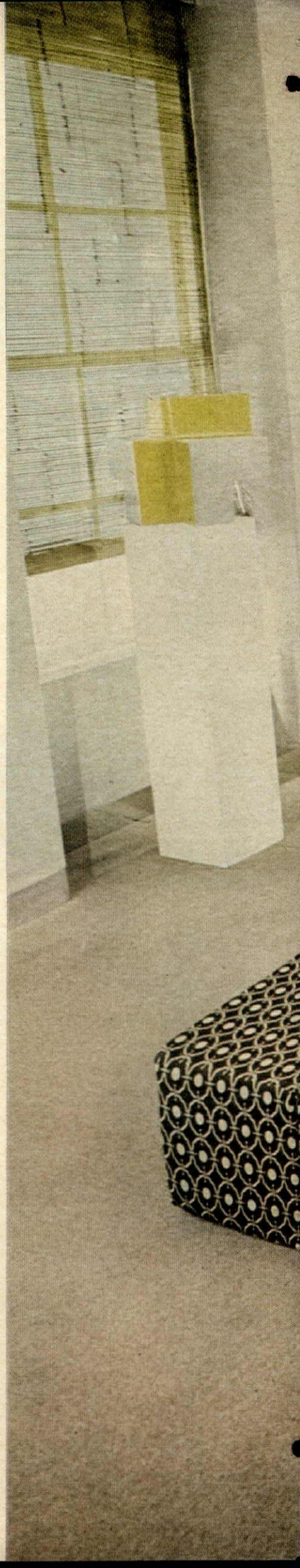





MASSEY

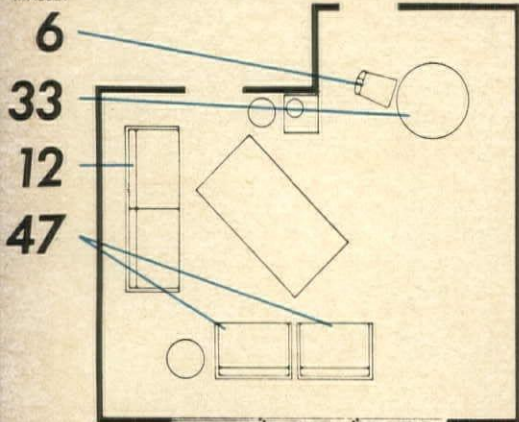

**For living
now**

Back to nature: pine, wicker, handcrafts

A marvelous room with "a feeling of living in a tree," says the designer Joseph Cuticchia of Kaufmann's, Pittsburgh, has plywood wall paneling and very new, natural, knotty-pine furniture. "It's a concept of life, a craftsman's room, earthy." Cushions on the love seat and chairs are covered in hand-spun Indian silk and more handworked things are all around—Navaho rugs, an Assiniboine Sioux quilt, beautiful baskets, and pottery jars. The floor is hand-molded rough terra-cotta tiling.

In the room plan: pine love seat (12) and armchairs (47) with Indian silk cushions. Round pine table (33) and double-doored storage cube both topped with beige Formica. Cane backed chair has white lacquered metal frame (6). All from Thayer

Coggin's Palomino Pine Collection designed by Milo Baughman. Terra-cotta floor tiles by Country Floors. Fir Planktex wall paneling by U.S. Plywood. Rugs and quilt from the American Indian Arts Center. Room at Kaufmann's, Pittsburgh.



Bedroom to live in all day

The sitting bedroom, a beautiful place to relax and unwind, read, sew, look at television. "See it as a living space and furnish it in an individual way," says the designer John Greene of Hudson's, Detroit. "If a great big sofa is relative to your needs or a little dining table for quiet meals alone, fine." Pulled away from the wall, the fourposter bed is lacquered yellow, set against Creamy Apricot walls on a Pompeian Red carpet. "Colors to make anyone feel pleased and comfortable."

Shopping information, page 144

In the room plan: single fourposter bed with yellow lacquered finish (43). Octagonal table copied from an original in the Woburn Abbey Collection (48). Pale pine-finished Chippendale armchair (1). Tufted sofa (23).

Corner cabinet of pine, with open shelves at top, doors below (41). Roll-around ottoman (2). All by Baker. Wool carpeting by Karastan. Bedcover in Moygashel Irish linen. Sheets by Wamsutta. Painting by Anthony Tortora. Room at Hudson's, Detroit.

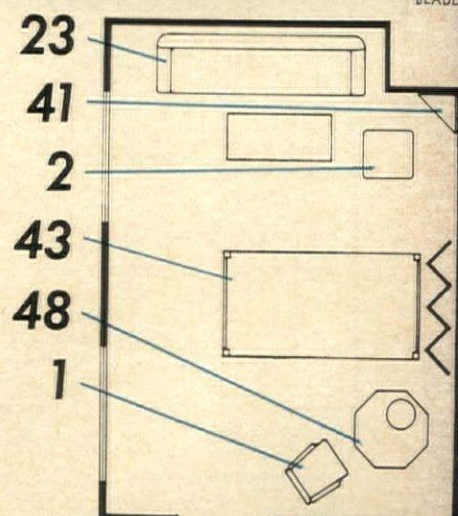



MASSEY

17

39

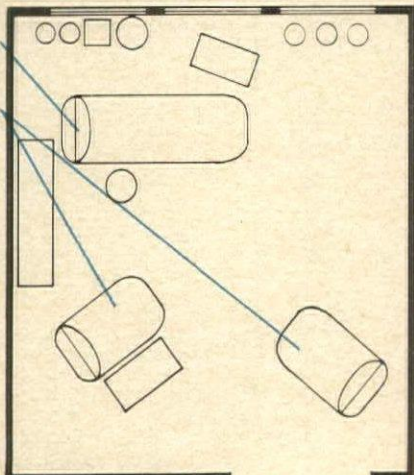

For living now

Garden sitting room with sunshine color

Wonderfully casual and comfortable, a garden sitting room with low-down chairs like big, puffy pillows, plaided in Real Red and Chrome Yellow. "They're great for feet-up reading, entertaining, or enjoying afternoon tea, as we show here, with a little champagne on the side," says Angelo Donghia, of Burge-Donghia, who designed both the furniture and the room for Lord & Taylor, New York. Sisal carpet, the lacing of greenery at the windows, all help to give this room a fresh feeling.

In the room plan: chairs (39) and chaise (17) looking like separate cushions are one-piece units padded with foam and Dacron, designed by Angelo Donghia of & Vice Versa for Interior Crafts. Cotton and polyester plaid

fabric from & Vice Versa and also the "Straight as an Arrow" mauve, blue, and green wallpaper. Coffee table, stool, and serving bar-cart all made in Cicolac by Beylerian. Room at Lord & Taylor, New York.

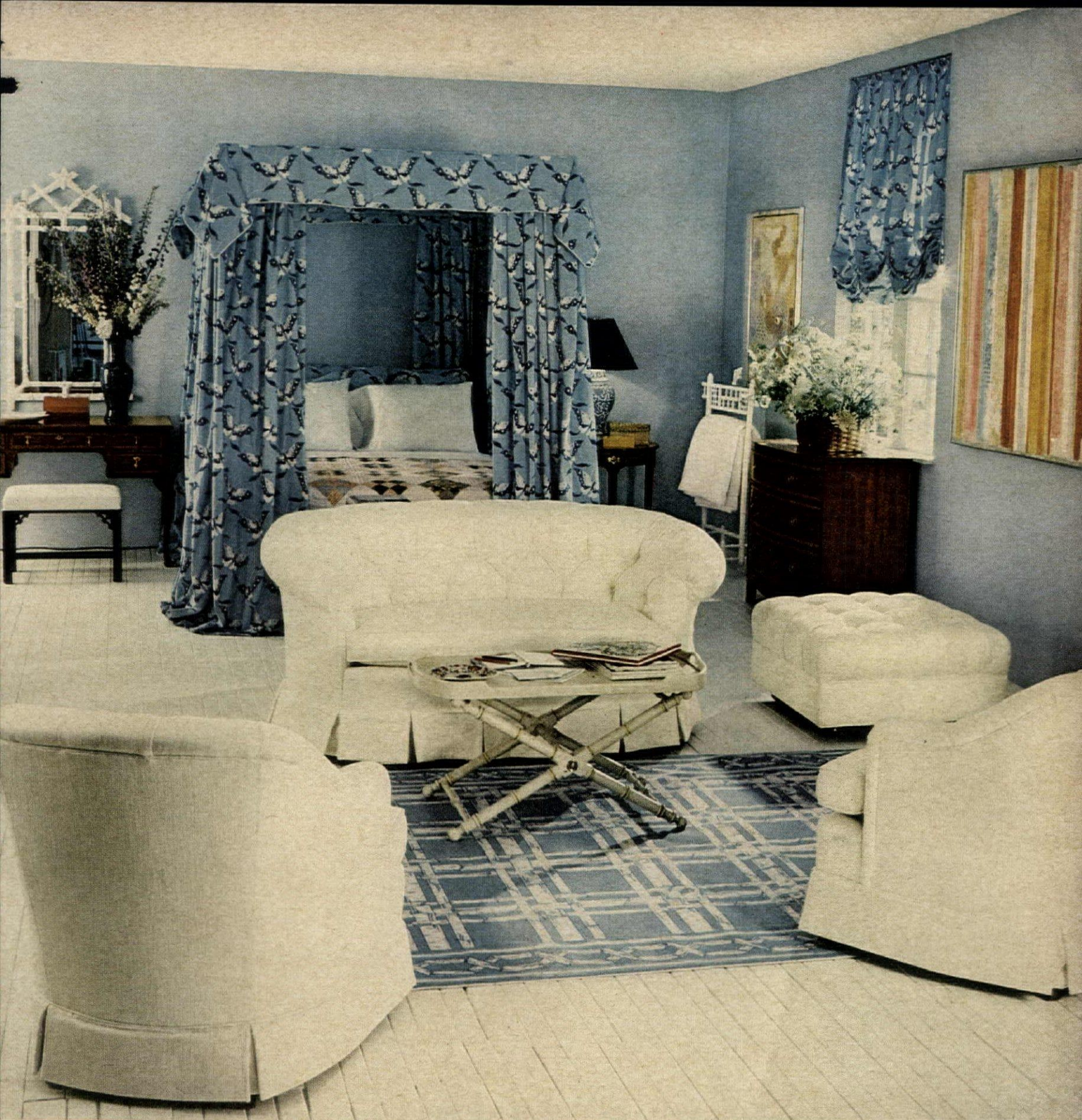

Heavenly bedroom all in blue and white

For a romantic bedroom sitting room, a shell of Blue Sky blanketed with white, in the soft down-seated chairs, love seat, and ottoman and with more white on the painted wood floor. "A calm, serene room for resting and relaxing, as well as sleep," suggests the designer Ann Bolitski of Jordan Marsh, Boston. A butterfly print billows around a Sheraton style fourposter bed and at the windows. All the other pieces of handsome furniture are faithful replicas of eighteenth-century designs in walnut and solid mahogany.

Shopping information, see page 144

In the room plan: down-cushioned love seat (32). Matching armchairs (20) and ottoman (15). Queen Anne style writing desk (27). Flip-top table (13). Bow-fronted chest (11), Chippendale-style bench (4). Fourposter bed (18). All by Henredon. Blue butterfly cotton fabric "Cathay" designed by Julian

Tomchin for Connaissance. "Pavillion" wool rug designed by Julian Tomchin for Harmony. Pale blue sheets and white blanket by Martex. Paintings by Robert Natkin from the André Emmerich Gallery. Room at Jordan Marsh, Boston.

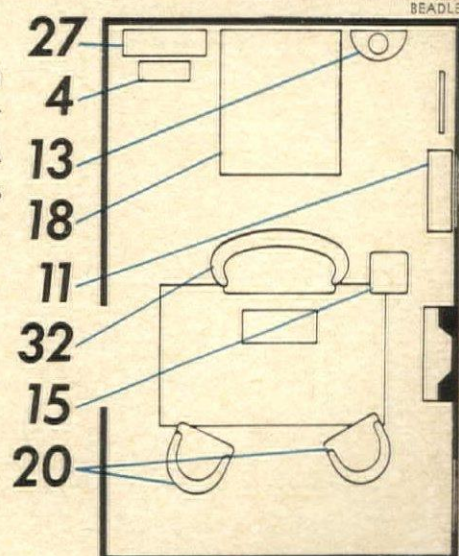



MASSEY

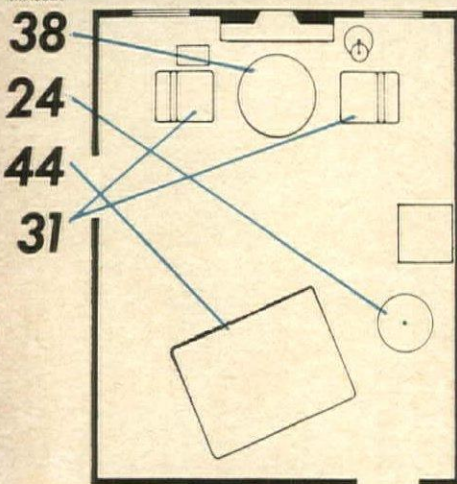

For living now

The bed-living room, a way of living now

A room of soft naturalness and rounded contours where you can live and entertain easily. The great bed with its pile of pillows is covered with a hand-printed fabric, and there's a handwoven touch in the sisal carpet. Seating, leathery looking, has a soothing rounded quality. "This is a very today way of living. We want to simplify at home while the world around us gets more complex," says the designer Farrell Fullerton of May Company, California. Mantel is pine, and the shutters and doors.

In the room plan: foam-filled tan, vinyl-covered easy chairs (31), mushroom ottoman (24). Polished chrome glass-topped table (38). All by Selig. Double-size mattress and box spring (44) Beautyrest Supreme by Simmons. 12-inch squares of sisal carpeting by Continental

Importing. Shutters and doors of ponderosa pine. Cotton fabric on bed and pillows from The Design Works of Bedford-Stuyvesant for Connaissance. African sculpture from the Henri A. Kamer Galerie. Room at May Company, California.

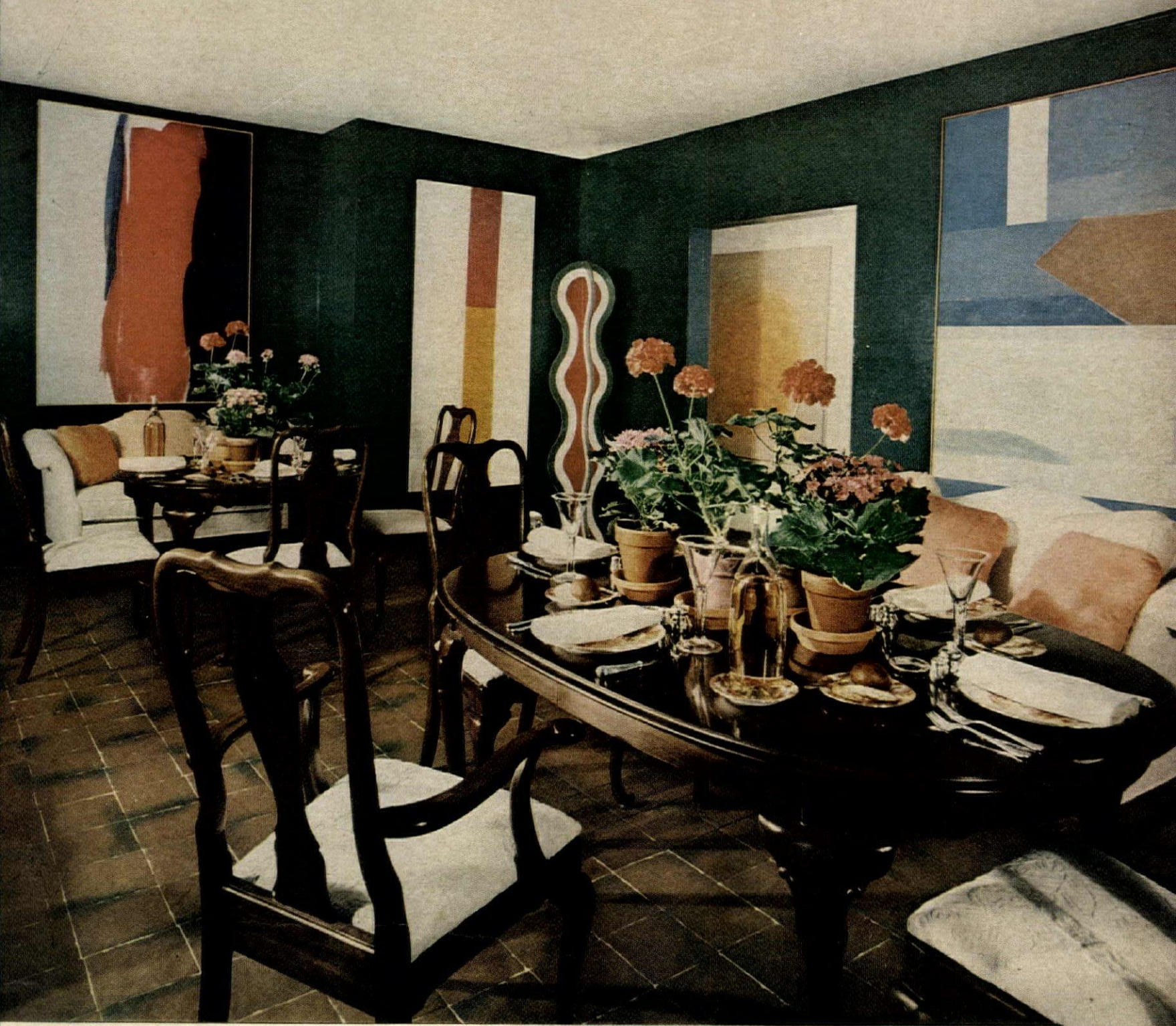

Two-tabled dining room art gallery

Perfectly organized, a dining room with two tables, one round, one oval "to suit the versatility of today's life," explains the designer Elaine Eisen of Altman's, New York. "Sometimes there are only four for dinner, sometimes it's full house. Whichever it is, you can sit in an intimate group." Lacquer Green walls are hung with modern paintings, making a fabulous background for Queen Anne style furniture. "The dining room is perfect for art, better than a hallway where you pass it by."

Shopping information, page 144

In the room plan: oval table, round table (30), Queen Anne side chairs, matching armchair (5) all from Ethan Allen's Georgian Court Collection by Baumritter. Chairs and love seats (9) covered in white crewel "Calcutta" from Ethan Allen's imported fabric collection. "Red Aves" Royal

Crown Derby china. Ceramic tile floor by American Olean. Paintings, left to right, by Cleve Gray, Calvert Coggeshall, Thomas Stokes, and Kenzo Okada. Sculpture by Paul Feeley. All from the Betty Parsons Gallery. Room at Altman's, New York.

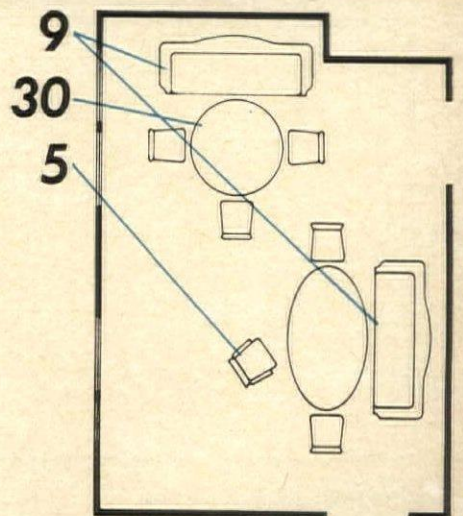

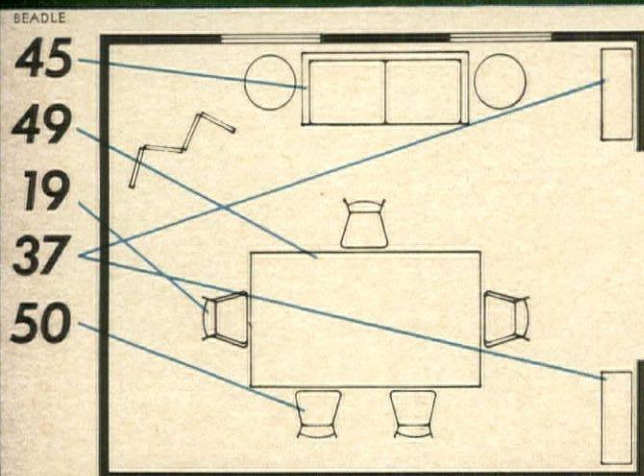
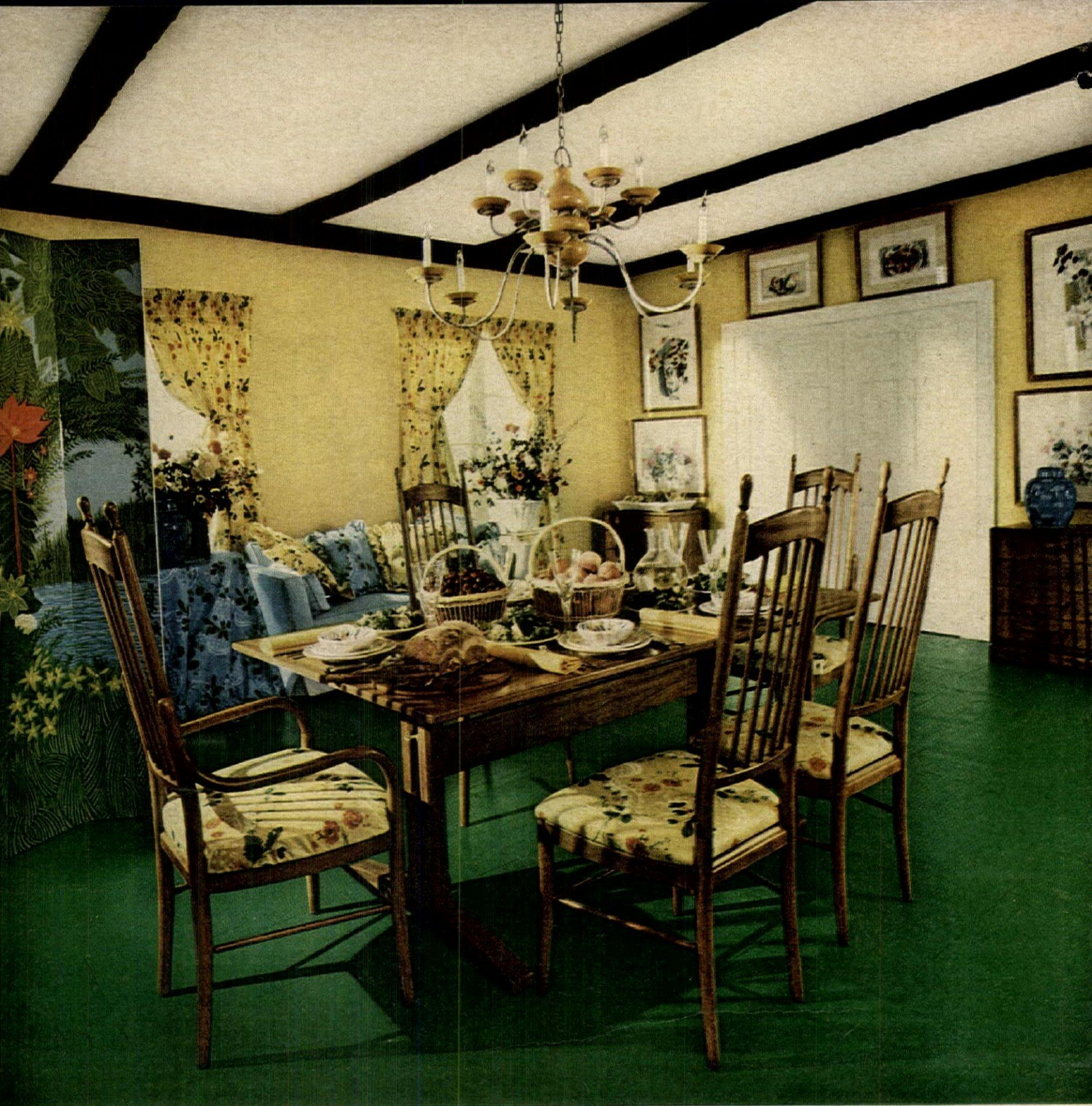

Dining sitting room like a garden

All the colors from a sunlit country garden flower in this dining room "bringing nature indoors—this is what everyone is thinking about today," reflects the designer W. Dare Snyder of Strawbridge & Clothier, Philadelphia. The floor is painted grassy green, golden Pineapple washes the walls, Blue Sky gentles a love seat. The Shaker-inspired furniture has chairs in the flowers-in-the-sunshine print that ties back at the windows.

In the room plan: slim spindle back armchair (19), matching side chairs (50), dining trestle table (49), and four-drawer chests (37) all from the Benchcraft Collection by Drexel. Love seat (45) covered with rayon and cotton also by Drexel. Yellow chintz on chairs and at windows, "French Rose"

permanently glazed cotton, Zepel protected, from the Designer's Choice Collection by Schumacher. Screen painted on canvas by R. Elliot at Isobel Worsley Gallery. Framed pastels by Philadelphia painter Hobson Pittman from the Babcock Galleries. Room at Strawbridge & Clothier, Philadelphia.

**For living
now**



Library living room in brilliant color

This library sitting room is furnished in an elegant traditional way "but strong *untraditional* colors and good plain cottons give it an updated, casual look," says the designer Paul Kettering of Woodward & Lothrop, Washington, D.C. Bittersweet is on the walls, glosses the étagères, and wraps an open-arm Chippendale chair. Sun Yellow blazes on a pretty tufted love seat and Kumquat on a second armchair. Little white banquettes built in beside the fireplace are bright with many pillows. *Shopping information, page 144*

In the room plan: Parsons desk table with white lacquer finish (29). Hardwood étagères (36) lacquered Bittersweet. These and the coffee table with cane top (35) by Lane. English tufted love seat (3) in Sun Yellow Scotchgard-treated cotton from the Barclay

Collection by Hickory Chair; and from their James River Collection, open-arm Chippendale chairs (21). Beveled oak planks on the floor by Bruce Flooring. Curtain rods and fittings by Kirsch. Graphics from Marlborough Graphics. Room at Woodward & Lothrop, Washington, D.C.

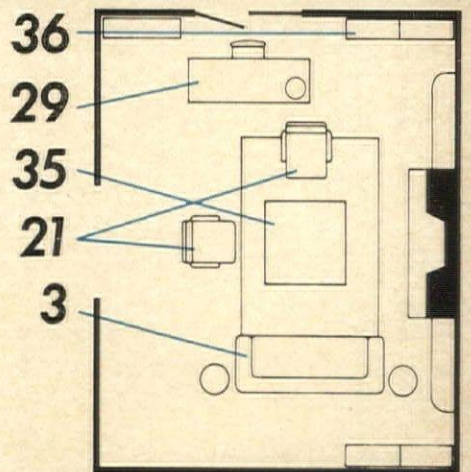



MASSEY

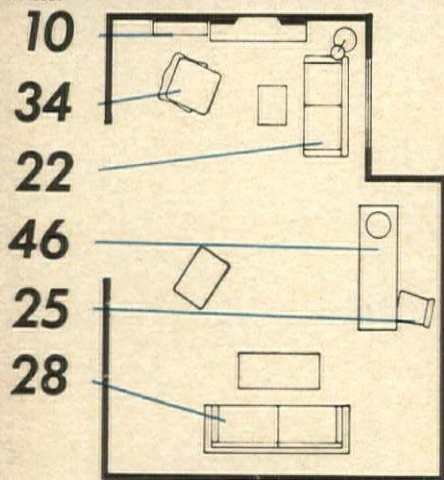

**For living
now**

That handcraft feeling in a live-in library

A calm, library living room, with lots of comfortable places to sit, designed by Dan Carithers of Rich's, Atlanta, to be changed "like you change your clothes. You make it blue with cornflowers, pink with petunias, white with daisies. Add or subtract colorful paintings when you wish." The trestle table serves for dining, playing games, reading, working. Boards on the walls are shelved for books and the floor paved with tiles. Great hangups: bedspreads lined with sheets for curtains.

In the room plan: Tuxedo sofa (28) upholstered in natural linen. Love seat in leather (22). Both by Heritage, and from their Tour de France Collection, linen-covered bergère (34). From their Norman Court Collection, desk table (46), side chair (25). From their Kingsbridge Collection, chest (10).

Fabric on floor pillow by Agnona for Jack Lenor Larsen. Floor tiles from Structural Stoneware. Southern pine paneling from Union Camp. Curtain rods and fittings by Kirsch. Martial Raysse poster, silkscreen by Kenneth Noland from Poster Originals. Room at Rich's, Atlanta.



Move-around curves in a living room

With white-painted sculptural plywood forms you can alter the architecture of an ordinary boxy space. Shapes here create curves around soft Ultramarine Blue sofas and chairs. "They're hollow inside, quite portable, so the room can be arranged and rearranged in many different ways," says the designer Douglas Brinkman of Joske's, Houston. "At night spotlights play up the curves, adding to the excitement." Pattern in this entertaining room is kept underfoot in a geometric carpet. *Shopping information, page 144*

In the room plan: love seats upholstered in textured Du Pont nylon protected with Zepel (40). These and matching armchair (14) from the Contemporama group by Flexsteel. Stainless steel cube table and glass-topped lamp table by John Vesey. "Chevron" geometric carpeting

of wool and nylon from the New Vista Collection by Couristan. Stacking cubes in opaque white plastic by Albrizzi. Eight curving forms when put together make a circle or a square, designed by Gary Dobosen. For additional variations see page 152. Room at Joske's, Houston.

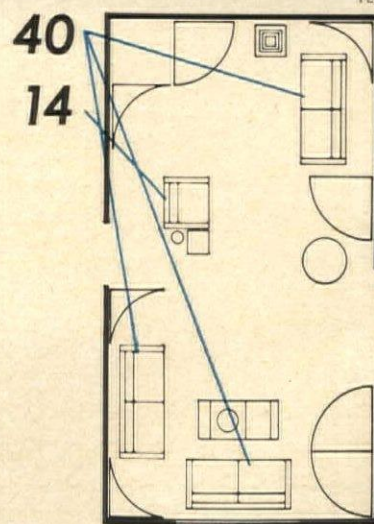

ALL PLANS BY BROTMAN

“It’s whether one’s happy in an environment that counts”

Jack Lenor Larsen and Robert L. Schwartz take part in a rap on living.

EDITOR’S NOTE: Jack Lenor Larsen, weaver, designer, explorer of fabric technology, is a dominant force in environmental design. And through his long associations as a trustee of the American Crafts Council and the Haystack Mountain School he has given leadership and help to young designers in many areas. His great retrospective exhibition of textile designs at the Boston Museum of Fine Arts this year was followed by another important accolade: the 1971 Elsie de Wolfe Award from the New York Chapter of the American Institute of Interior Designers. A scholar and traveler, he has fabrics in permanent collections of museums all over the world.

Robert L. Schwartz is a writer and business man whose wide-ranging interests all have a common thread—innovation. He was a member of the Columbia University Seminar on Technology and Social Change, created the Motel on the Mountain in New York, is one of the owners of *New York* magazine, and president of the Tarrytown Conference Center, the largest conference center in the United States. He is also on the board of directors of Esalen, the group therapy organization. A man with strong feelings about good design, as a guest speaker with Mr. Larsen at the Elsie de Wolfe award luncheon, he stressed a theme that the purpose of life is the quality of life. He begins the conversation . . .

This is one of the most exciting times we’ve ever gone through. So many things are going on—in architecture, uses of space, uses of institutions, the church, the school, the family, social relationships, none of which have really performed their proper function for some years. Everything is due for recycling.

LARSEN: I agree this is a good moment to be

living. Any time when a new world is being formed and all hell breaks loose is very creative. The quiet that we dream about, the static situation where we know where things are at, is really very *uncreative*.

SCHWARTZ: We should feel optimistic, because optimism is one of the lubricants of society. The general trend is so affirmative, so strongly upward, away from brutishness, taking advantage of each other, without exploitation. It really has been dog eat dog part of the time—for survival. But now we’re beyond survival and we have a sense of the higher order of human need. We are finding some meaning beyond survival. Experimenting with new ways.

LARSEN: This is reflected in what people want today. What they are searching for is not just a material sense of wholeness, having all the things they want, or of having arrived, but a sense of total design in their lives—in terms of the space they use both emotionally and physically. The feeling is what’s the point in buying a new car if it pollutes the air around you.

SCHWARTZ: We hear that young people are anti-things. But they’re not. They buy records, phonographs, tape recorders, domes, they find life styles, Volkswagen buses that express what they need. It seems to me that the expression of the new thinking will not be in the total disregard for products, but a disregard for some products that now exist.

***The really new living pattern
will involve places to hang
your hat for a change of scenery.
The second house, the vacation
house, the place that needs
no upkeep, that’s almost
stamped out of plastic.***

LARSEN: Some things are really obsolete and need to be rejected—our school system for example has to be remade from the bottom

up. If it is not our whole culture will collapse. If Rome had had more little revolutions, it might have been able to sustain itself. It’s when you become brittle and so crisp that you have no resilience and can’t cope with the minor shifts, that everything falls. I regard the new patterns in shopping as one of these minor shifts in the system. Our idea of luxury is changing, for example, space and sun and time are luxuries, so is homemade bread and country cheese and all things not stamped out of the mass mold.

SCHWARTZ: Rejection is good, it precedes growth. Look at nature, the butterfly from the caterpillar and the snake throwing off the old skin. It’s quite sensible in the biological sense that we reject any old skin we’re supposed to put on. As I look around at almost every single shell that we’re supposed to fit in as part of our life, or my children should fit in as part of their lives, I find it is not valid for what it is allegedly doing. Not the family for love and security, not the school for education and growth, not the church for comfort and tradition. They’re all essentially limiting and not growth-making. I admire the new forms of social relationships, which have more candor.

***We are looking for something
much closer to a natural kind of
way to live. It’s a question of
getting closer to real natural
tastes and inclinations.***

Look at the success of the Club Méditerranée back-to-nature resorts, where they don’t want you to use your second name, no one cares about your income, and you use beads instead of money! It seems to me that societies grow and ideas survive in society, in the same way that they do in the biological Darwinian sense, through mutants. Mutants somehow get along a little bit better, find a new way to do it and survive. All of the ideas

I'm talking about today are mutants that might have a chance, might show us a better way.

LARSEN: The common denominator in a lot of the thinking today is a new trust of feeling or at least a wish to trust feelings as opposed to systems or ideals, products, or whatever. Systems and rules don't seem to have much relevance as far as environmental design is concerned. Such as the idea that you shouldn't have this or that kind of taste, that you shouldn't be ostentatious, that you shouldn't strike out on your own. All these inhibitions that grew up in the middle nineteenth century under the idea of tasteful living for a bourgeoisie are really suspect now. The young simply think of them as hangups. They belong to mother's generation. Our generation rebelled slightly by saying we liked this kind of object instead of that, but in a sense that was not so revolutionary. What's the difference between the Mies chair and a Louis XV chair? They are both expensive, desirable status objects. What young people are saying today is, if you don't bother me I'm perfectly happy sitting on the floor—and I want somebody to sit with. I feel this is the revolutionary thing. It doesn't matter what the space is or where it is or what's in it, it's the people in it and whether one's happy in that environment or unhappy, whether one feels related or alien that counts. Of course there's still going to be room for beautiful things that are just nice to have or sit on or wear or whatever.

There's probably going to be a boom in handcrafts and special kinds of luxury goods.

I think the feeling is that they'll be accepted not for their status but for the feeling that derives from them. You'll go for a chunk of pretty velvet if it turns you on—not because your mother-in-law might think better of you if you have it.

SCHWARTZ: The revolution peculiar to our time is the revolution that has to do with the quality of relationships between individuals. This should become the first priority in all institutions—the family, marriage, the corporation, the school—not better work norms, not better products, not higher outputs, not better consumers, but people relating to each other better. And it seems to me that the revolutionary theme behind all this comes from a Hebrew philosopher named Martin Buber, who said that we are going from “I and it” to “I and thou”—from our relationship

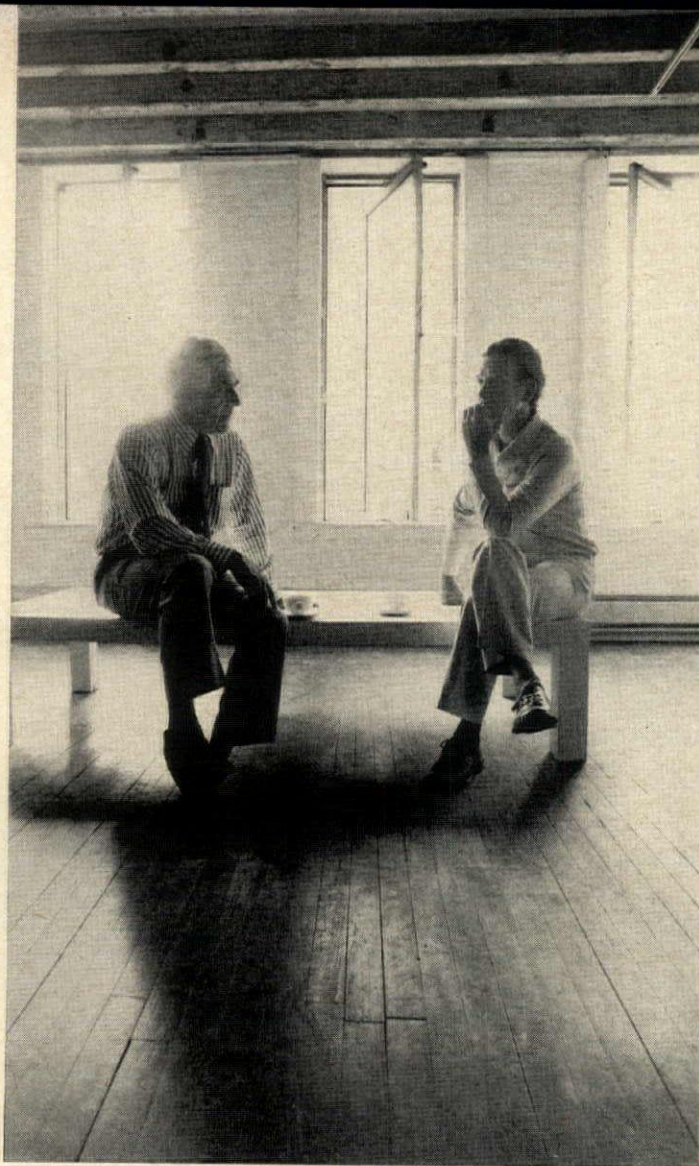

Rapping on living: Robert L. Schwartz, left, and designer, Jack Lenor Larsen. “What people want today is a sense of total design in their lives.”

to things, acquisitions, buildings, houses, essentially inanimate objects, to a relationship that has another person in it. “I and thou” is bound to be more fulfilling in its total sense than any relationship with an inanimate object. And you see this expressed in women's lib where wives have everything they want; they have more than their husbands do, statistically, but they are in revolt because the quality of their lives, having acquired all these things, has no meaning. They want a better relationship viability, a better relationship with themselves. Women's lib is not frivolous, I think it's the heart of what we're all saying today. What is the meaning of me, now that I've got everything? What do you do with life now that it's possible to have it? What do you do with I and thou? Our generation said to its parents: “If you're so smart, why aren't you rich?” And this generation says: “If you're so rich, why ain't you happy?” It's a better question.

LARSEN: A lot of your creative people still want to come to the city after school but they leave by the time they're thirty, which is entirely new. I think the city's existence depends on whether the cities can remain alive. It might be that we've outgrown the need for cities, but I tend to think that's not

the case, that the megalopolis trend will continue. But how does one make the city bearable?

SCHWARTZ: The city will come into its own much more strongly without the big office buildings, as the major corporations move out of the city centers. I see the city as a new university, as a place where people get together as part of the biggest show in town. As we grow more sophisticated, and have more special needs, we find people who share those needs are always in cities, they're not in small towns. If ideas, and rubbing against that kind of thing, are important to you, then the city will always exist. I'm sorry that the young creative people, they're bellwether types, are turning their backs on the cities. That really scares me.

We must start to make the city a garden in which people grow, not other things grow, not money grows, not finance, not transportation, but people.

Once we see this insight, that the purpose of all organizations, from the family to the school to the city, is to be a garden in which people can flourish in the fullest sense and design

a better life style, then the city will come alive. We are just beginning to explore social architecture, the design of how people should live together in urban places, now that we're past what I call brutishness or simple, fundamental survival living.

LARSEN: In the past, happiness wasn't much of a consideration in decorating one's house. I think there's been very little joy in it. It was a question of passing the test when somebody on the other side of the salt might wander in. It was a scary thing, full of inhibitions and taboos and questions of taste and timidity. If you did get your house fixed properly, then it was outlawed to children, dogs, and so on.

We should adjust to the glorification and pleasure in everyday things. The big thing is the difference between one's own spaces and the others next-door. Your house must say that “I'm me” and this place is “mine.”

and it might say it just through things one collects, the activities and the objects that make it personal. People feel today that artists' studios and lofts are nice places to be. They're the places where something is going on. You have this sense of identity. What is most important is (Continued on page 230)

CLEAN-SWEEP SPACE FOR LIVING NOW

Though originally tempted to break up the 75-by-100-foot, floor-through-of-an-1890s warehouse into twenty small rooms, *Artforum* publisher Charles Cowles realized he wanted the experience of living in one enormous room where big unobstructed spaces offer an almost Oriental serenity rarely available in city apartments, plus vast hanging space for a growing collection of works by young artists. Cowles went to Mark Hampton of McMillen, Inc. for advice on how to treat the space without using lots of furniture. Since the warehouse dated from the time when even factories were well built—this one has a cast-iron façade—Cowles made only minor structural changes. Once having resolved where to put a free-standing L-shaped wall that would x out the functional parts of the space—bedroom, library, storage—he painted everything white, sanded an undulating but sound wood floor, coated it in polyurethane, hooked up gallery fashion a system of track lighting, replaced gerrymandered window panes, then landscape gardened the big white columned room with a jungle of plants. The furniture moves as often as the paintings and the plants. The view of the living room, *opposite page above*, is at right angles to the big view of the living room, *both pages*. *Opposite page below, left to right*: The library; the bedroom with Dunbar bed; a kitchen that's mostly an expanse of butcher block, standard white kitchen equipment, food art on the counter. *This page below*: Along a gallery of windows in living room, a part of Mr. Cowles' collection of works by young artists: John Clem Clarke, Llyn Foulkes, Nigel Hall, Robert Hudson, Tom Holland, Gary Kuehn, Ronnie Landfield, Jeffrey Lew, Peter Reginato, Ed Ruscha, Keith Sonnier, John Tweddle, William T. Williams.

TOM YEE



EVERYTHING
- IN ONE
ENORMOUS
ROOM

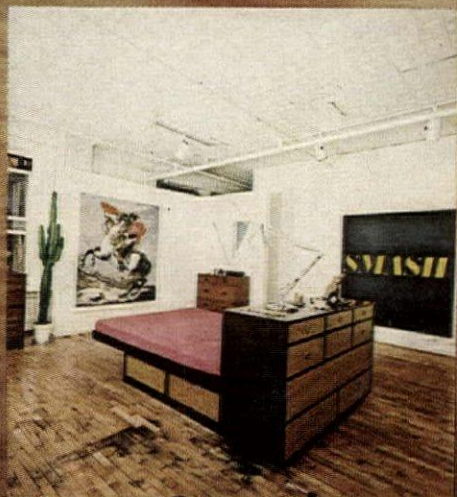
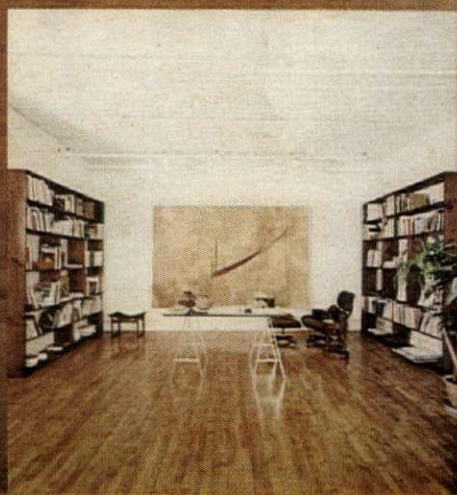
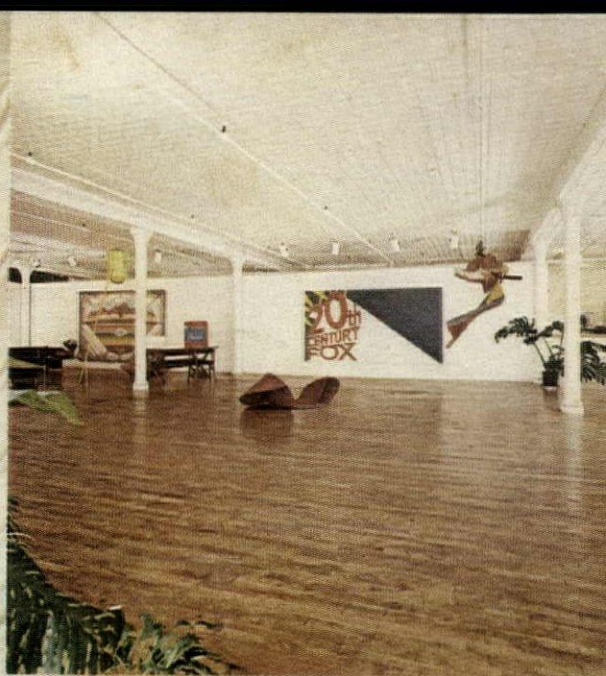



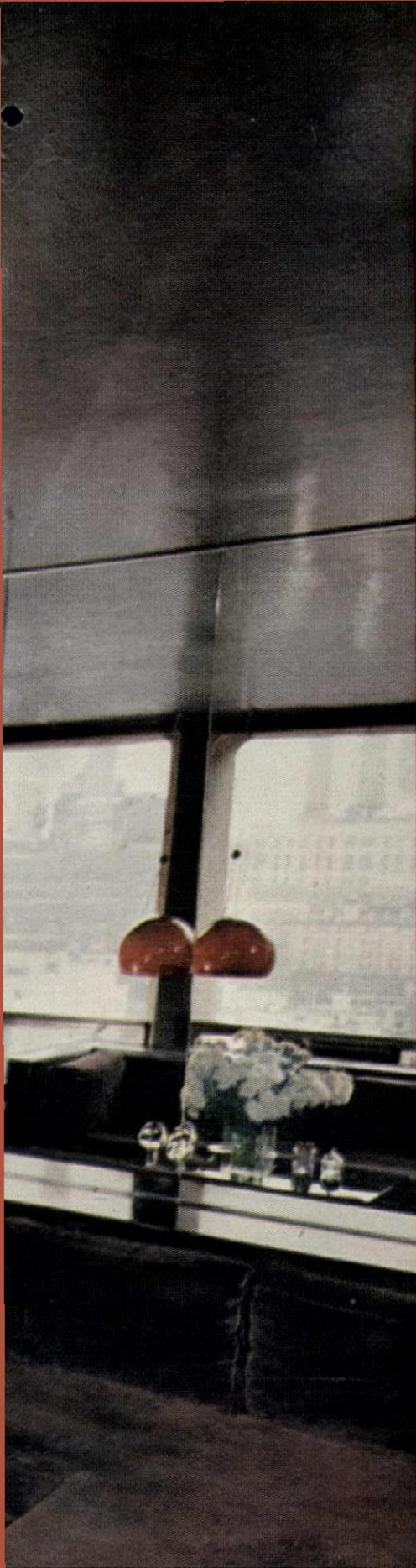

CLEAN-SWEEP SPACE FOR LIVING NOW

BIG LOOK IN NOT-VERY-BIG ROOMS

"My apartment's an environment for people, not objects. I used to be an incurable collector, and I still can't bear to part with things. But I don't want to look at them all the time. I work with objects and color all day and I want a restful place to come home to, to entertain friends in—so I put everything behind closed doors and reduced all the furniture to one big piece per room." In graphic designer Gilbert Lesser's living room, *left*, one whole wall has shelves for books, records, stereos, television, all invisible behind touch-latch doors, *insert*, until wanted. Furniture is at a luxurious minimum—a low, comfort-

able, 12-foot-square sofa-island centered on a steel and glass coffee table, and even that works for storage: Doors on one side of the sofa pull off so boxes can be stacked, pictures pushed under the hollow seat. To further increase the illusion of spaciousness in a not-very-big room, Mr. Lesser mirrored the wall opposite the windows, doubling a lovely view, covered the sofa in Charcoal linen velvet, and painted out every paintable surface—ceiling, walls, window frames—in shiny Charcoal. The closet-lined, spot-lit Tangerine hallway, *above*, the only bright splash in the apartment, can be glimpsed from every other room.



BIG LOOK IN NOT-VERY-BIG ROOMS *continued*

VAN CUYLENBURG

Each room in Gilbert Lesser's apartment is a one-color environment glossed in shiny paint—"the best way I know to bring dark colors to life." The dining room *above*—which he created by building a 2-foot-deep storage wall from floor to ceiling across one end of the living room because "I really prefer a separate dining room even if it's tiny"—is a Beach Plum cube just big enough for a table and four chairs. The bedroom, *right*, is a blend of warm naturals—shiny Brown Velvet walls, paler corduroy upholstery, a Camel-y llama blanket—with storage hidden behind every shiny surface. One wall, *opposite page top*, holds closets and the door to the hall. Doors on another wall, not shown, conceal floor to ceiling bookshelves; and the wide, solid-seeming

painted frame around the room-size bed is all storage. Sliding doors on both sides conceal shelves, trapdoors in the top of each side flip back to reveal telephone, reading lamps, bedside paraphernalia. At the back, the top comes up in two sections to make a headboard, with ample space for blankets and pillows underneath.

OUT-OF-SIGHT STORAGE AND A ROOM-SIZE BED

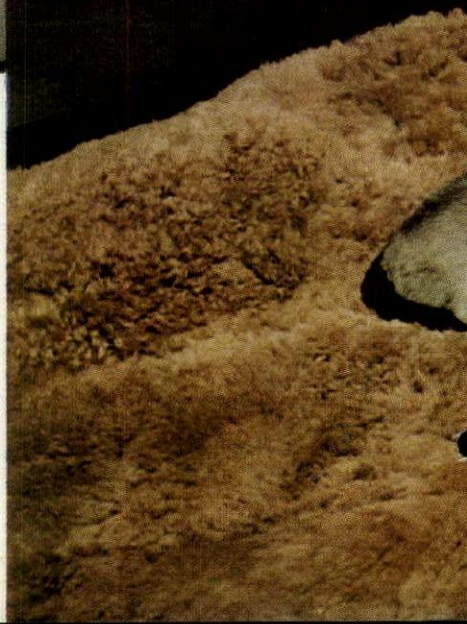

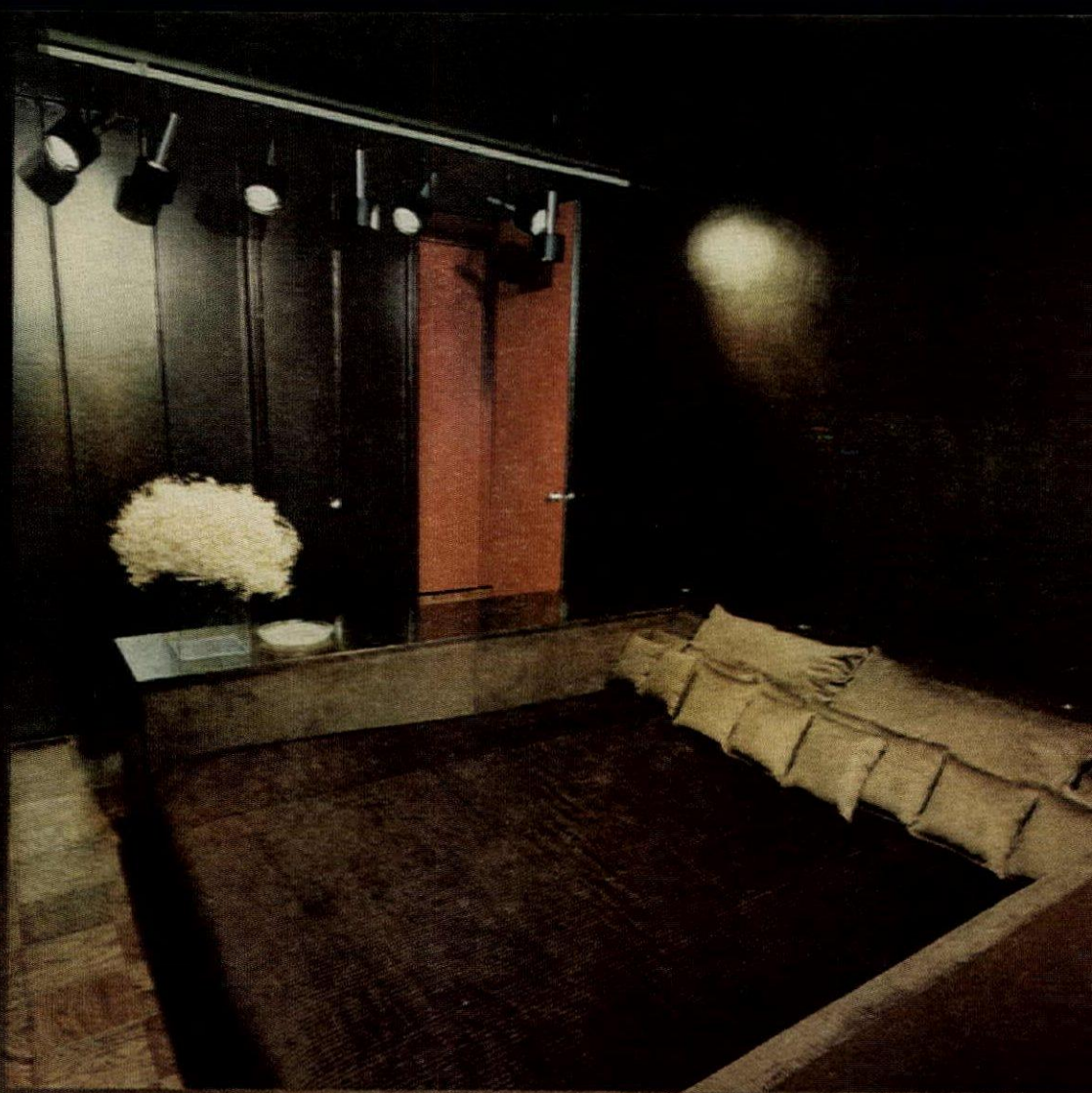

"We had lots of space but most of it was vertical, so we borrowed from the ceiling to make the bedroom." Designer François Catroux had only 400 square feet of floor space—one big double-story room, formerly an artist's studio, and a tiny adjoining apartment—to turn into a workable apartment for a young French business woman. He built a balcony along two sides of the living room, *far right*, for the owner, and instead of dividing it into three conventional rooms—bedroom, bath, dressing room—he left it all one. To suggest enclosure without stopping the eye and to give some privacy and protection, he encircled the balcony with a "see-through wall" of thin chrome poles and bookshelves. Leading upstairs from the center of the room is a marvelous spiral stairway by Roger Tallon that looks like a gleaming chrome sculpture. All the furniture was designed purposely low and simple to emphasize the height and openness of the room and to keep costs down. Catroux built platforms, covered each with the same sisal as on the floor, then topped them with large, brown cotton cushions pushed together to form a sofa or used alone. He used the same muted colors—brown and white touched with Tangerine—everywhere to give the apartment continuity, make it appear larger. To give the illusion of greater depth, he covered the walls, ceiling underneath the balcony with brown cotton, then painted the other walls and the open ceiling white. To the right of the stairway is a poster by Joseph Albers, over the fireplace a painting by Cruz Diez. *Above:* In the bathroom, sink and tub are exposed, toilet closed off at one end of the room. Pierced wood panels painted white replace curtains on all the windows, let in light, prevent outsiders from looking in. *Right:* Vertical poles emphasize height of the living room. *Bottom:* The house, at the back of a courtyard in Montparnasse—its traditional front hides a sweeping modern interior.

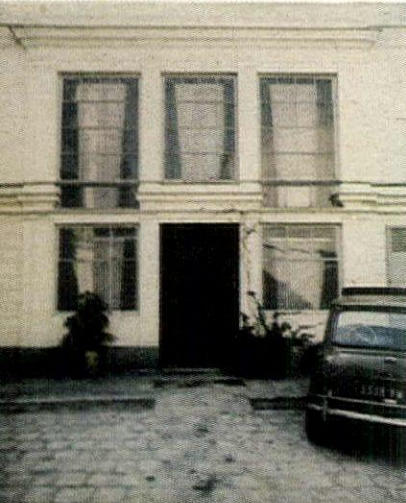

CLEAN-SWEEP SPACE
FOR LIVING NOW
**NONSTOP
ROOMS**

MASSEY





At the end of the balcony, *above*, is the bed, a mattress on a platform covered by a fur blanket and pillows by Revillon, over it a gouache by Gabrielle Terbotz. Brown walls and carpeting continue along the balcony to the bathroom, *left*, at the other end with its white walls and counter, built-in sink, and recessed tub. *Right*: Space from the small adjoining apartment was turned into a kitchen-dining room. Catroux confined the working part of the room to one compact area—everything is within arm's reach of the white Formica dining bar—left the rest of the space free for entertaining. This way, the owner can cook, be with her guests at the same time. All the storage shelves are open to emphasize the space beyond, show off pretty jars of marmalade, spices. *Inset*: The brown Knoll chairs form a conversation area around a stainless steel and white lacquered table. The walls are lacquered brown and on the floor is sisal carpeting.

MASSEY

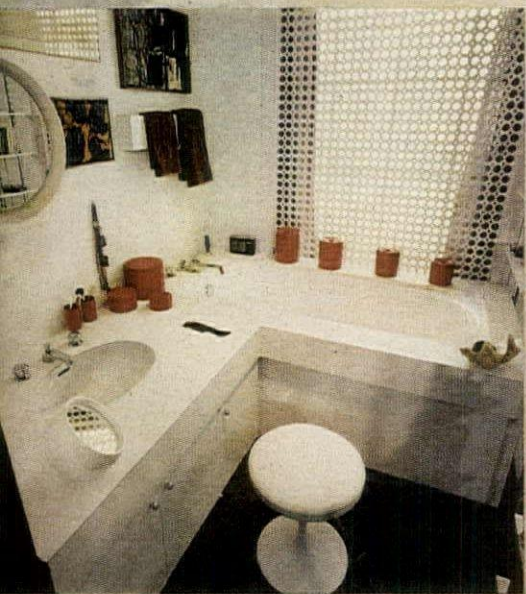

NONSTOP ROOMS *continued*
 BED-BATH
 BALCONY
 AND AN
 ENTERTAINING
 KITCHEN



LAND ART

The very personal garden of the Emilio Puccis

A garden carved into the earth

like an abstract painting

When the Marchese and Marchesa Pucci decided to redo the gardens surrounding the Pucci family's Tuscan villa, they consulted Milanese architect Gae Aulenti and created two highly untraditional gardens where their eighteenth-century Italian equivalents had been—one, a very abstract architectural essay in grassy terraces and cement borders that extend from the front of the villa along a long alley of trees to a pool; and the other, the exact opposite, a hillside of bright blooming plants, which makes as luscious and lyrical a statement as the terrace garden is pure and spare. Here, several views of the step garden as it falls away from the house.

DEBENEDETTI

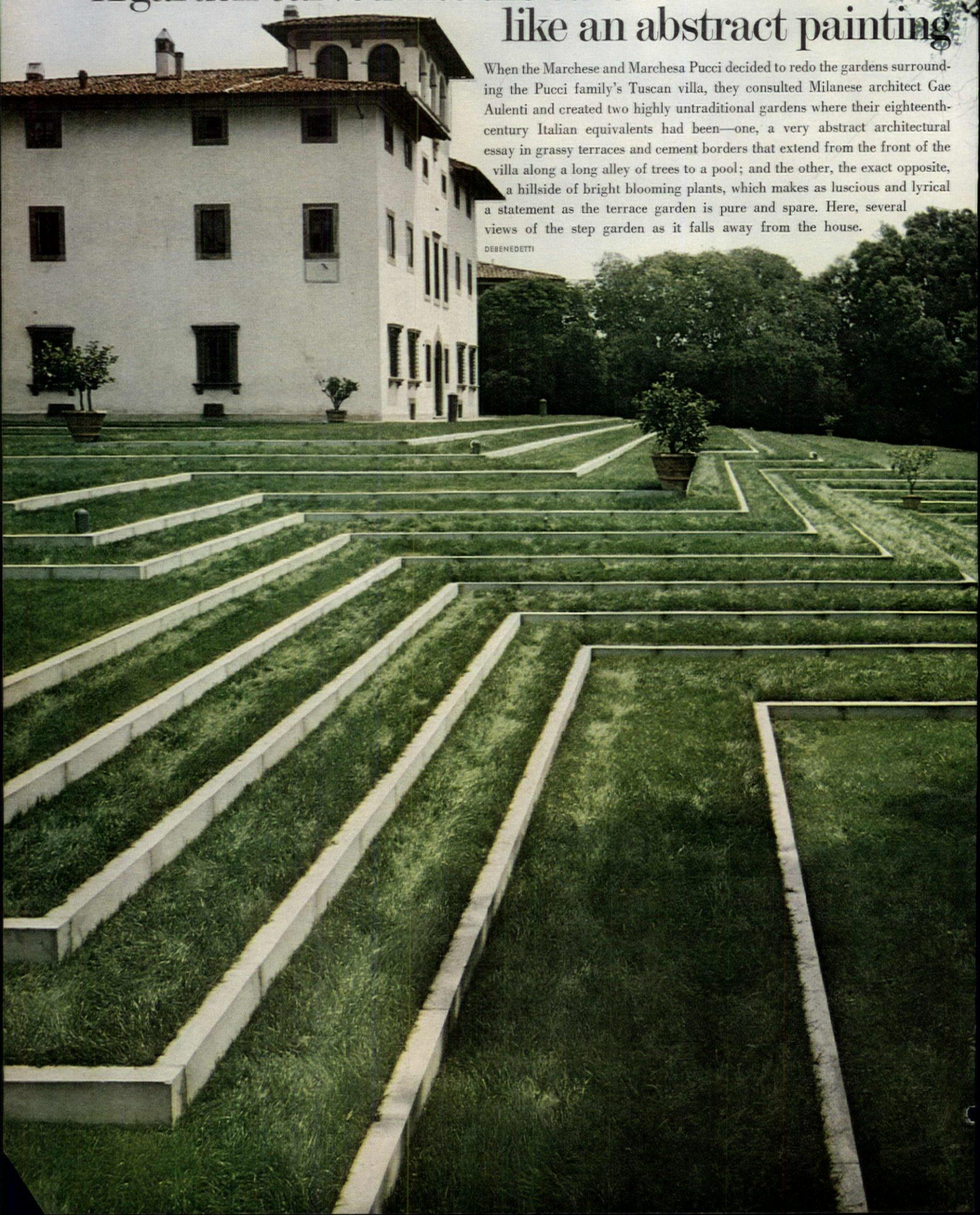

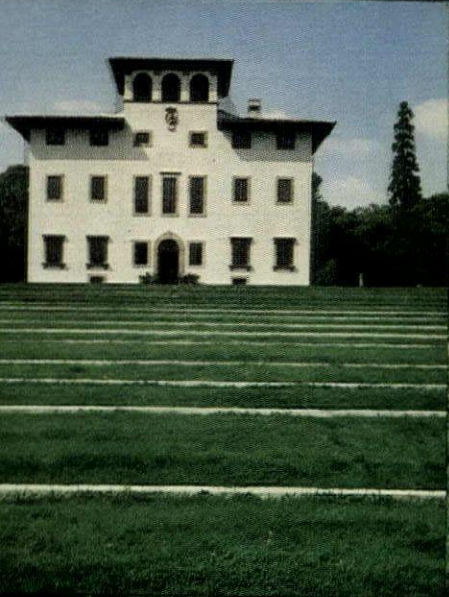

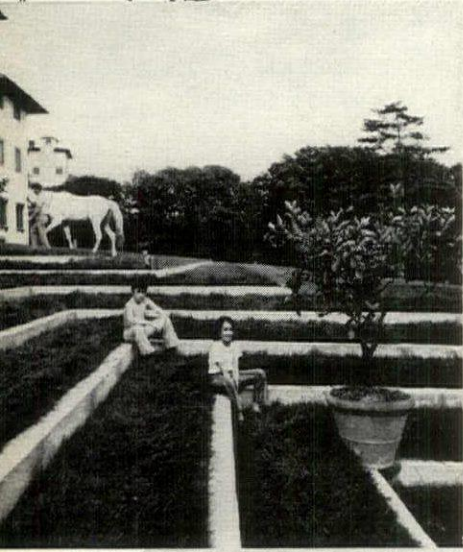
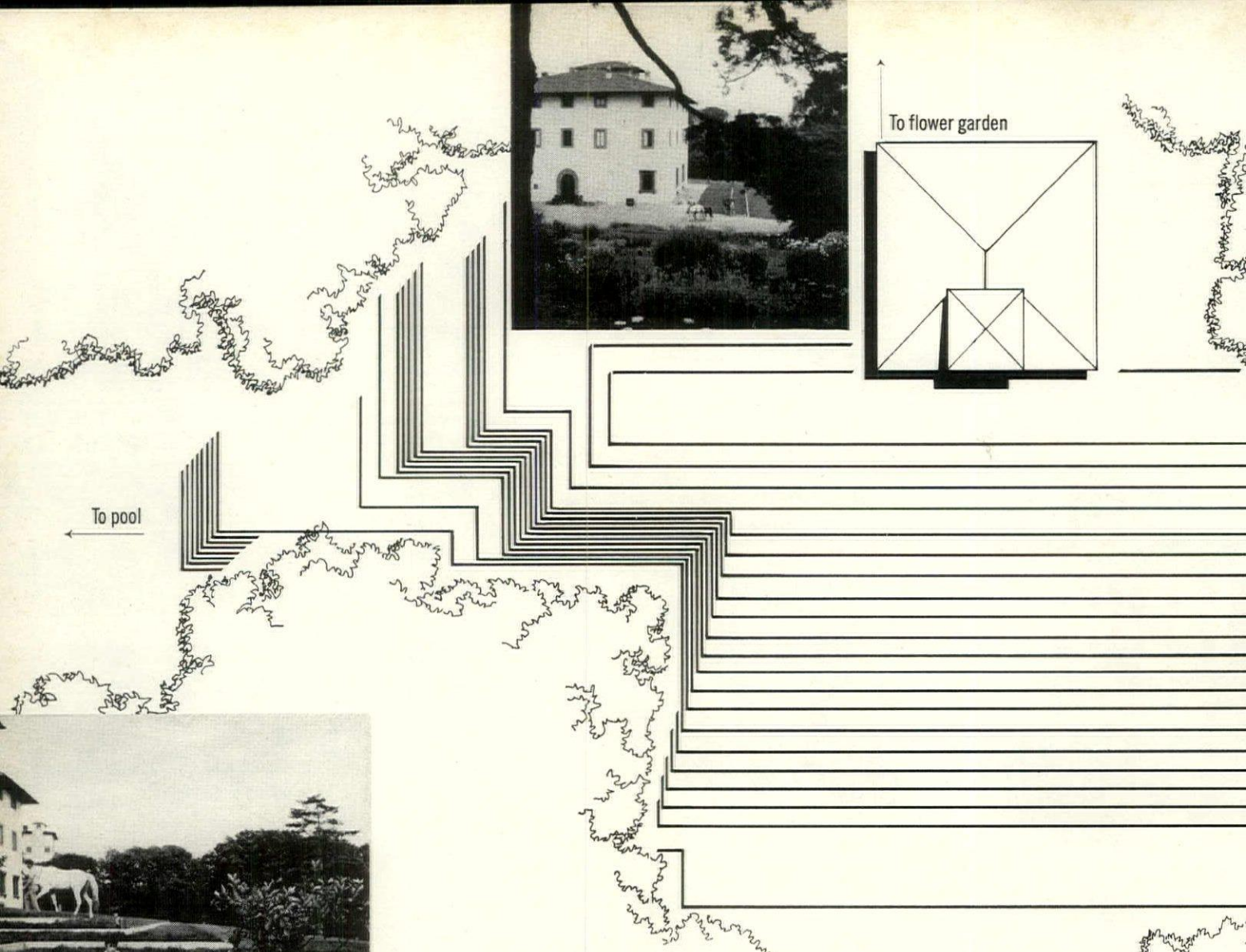

DE BENEDETTI



Architect Gae Aulenti wanted to do a very spare, sculptural design for her first garden. “I wanted an English garden, no flowers, just green. The principle I used was Land Art, an art that is written into the earth, signing the earth with a certain expression.” What she had to work with was a house that was “very clean and precise, very Tuscan with the stucco, tile roof and closed windows.” Surrounded by a bushy eighteenth-century garden with fountains and a park filled with trees brought from all over the world, the fourteenth-century house sits on top of a gradient rising 20 feet from a river running through the park below the house. To come down this rise of land from a jumble of geometrically planted bushes to a carefully planned step garden dramatized the starkness of the house—giving it the kind of sentinel quality of the barns jutting up out of a New England landscape. The first step in modifying the garden was to bulldoze terraces conforming to the contours of the land, then to lay out countless lengths of prefabricated cement borders, and finally to plant grass—three different varieties and a lot of seed to give the lawn strength. “It is constantly being watered since Tuscany is not the best land for lawns,” says the Marchesa, “and once it’s finished being mowed from top to bottom it’s long again on top. The process is continuous.”

The drama of the garden, since steps have always been part of gardening tradition, is in the scale of the terraces and steps. In contrast to this pure expanse of green and white, the Marchesa wanted flowers behind the house. Miss Aulenti designed a tiny valley of flowers behind the house, into a stand of dark trees on the site of what had been a formal cutting garden. The result is a rustic, almost wild looking garden was to have flowers blooming from April to October.

LAND ART

A sweep of flowers like an Impressionist painting

OPPOSITE PAGE: Bright splashes of color punctuate the hillside to the back of the house. THE PHOTOGRAPH ON THIS PAGE, LEFT, the dramatic perspective of the garden’s concrete borders as they fan out from a point. The lemon trees punctuate the intersection of the terraces. FAR LEFT: The Pucci children, Laudomiro and Alessandra, the horse and groom, give a sense of scale. TOP: Looking from the top of the hill down the rise behind the house down through the existing garden to the back of the house, and the beginning of the step garden to the side. THE ARCHITECTURAL PLAN OF THE GARDEN, ABOVE, shows the terraces stretching below the house like contours





One woman's adventures with her three decorators
"OF COURSE
THIS APARTMENT IS
OURS,
not
mine"
By Susanna Rattazzi

Susanna Rattazzi, shown in her New York living room, *above*, an Italian writer, traveler, mother-of-six intrigued by the richness and diversity of the U.S. today, determined to live here part of the year. This is her account of the friendship, wit, decorating skill, sheer stamina, and imagination involved in creating a background for her inexhaustible love of life.

Everyone said I was crazy to have more than one decorator do my apartment. "You'll go mad," they said. But I didn't and I have an apartment and three friends. Bob is tall and has curly hair; Mark is tall and wears a long coat; Vincent is French.

I went shopping with them across New York; we began at Fifty-seventh Street and ended in the warehouses. I tried to explain to them that I hate anything that is pompous and binding; that if you like to be free your house should give no idea of constraint. I think the three of them imagined I had a taste for little Louis XV tables and dark green velvet.

But to understand one another you have to know each other; and it takes a little time. Mark talked to me about his daughter and Bob about his mother and Vincent about Proust. I know they were all horrified at my lack of knowledge about furniture and anyway at my incredible taste. Vincent said, "C'est joli, gaaa?" Bob said, "Well, don't you adore it?"



HORST

And Mark said, "I hope you will like it." While they waited for my answer I could see their eyes staring despairingly into the probabilities of my crazy judgment. I had tea with Mark and coffee with Vincent and vegetable juice with Bob. I tried out on them what I wanted to write in my articles and closely studied their reactions. Bob generally laughed madly, Mark pretended he was not shocked, and Vincent was faintly and politely amused. We lived for practically two months, the workmen, the upholsterers, the contractor, Bob, Mark, Vincent, and I, in this unfinished flat. We bought too many flowerpots for the cachepots and then too many cachepots for the flowerpots and always, anyway, too many flowers for Francisca to water. The flowers died. So Bob came in the morning and watered them, then Vincent came in the afternoon and had them watered, and Mark came later and watered them again. And the flowers died because they had too much water.

Vincent and Bob and Mark don't under-

stand Francisca; Francisca doesn't understand them. Francisca is very thrifty and thinks she ought to prevent me from spending money. Especially on flowers, which I adore, and she considers a bad investment. "These boys will kill me," I said one day when six more cachepots arrived from God knows where and there were no flowers to put into them. "I don't know," Francisca said "si la van a matar, but one thing is sure la van a fundir." (They are going to ruin you.) With Vincent, I go to the theatre; with Mark, I go to the galleries; with Bob, I go to the health food shop. When I walk down the street with them, Mark covers me with his umbrella, Bob carries my parcels, Vincent holds my arm. With Bob I have a schoolboy friendship and we giggle about every foolishness until people on the streets turn around and look at us slightly shocked. Mark is my counselor, he has such a sweet steady way of seeing things. With Vincent, who is French, we have this saying "vous" to each other which makes it a more social re-

lationship. Vincent likes to read, Mark likes to paint, Bob likes to cook. I like to read, paint, and cook.

We have changed everything around five times; from the dining room to the living room; from the library to somewhere else. We have hung pictures on different walls and covered the walls with different materials. We have made mistakes and have grudgingly admitted it. We have tried to make the apartment look as if it were here from ever, growing on its own.

Of course this apartment is ours, not mine; it is Mark's and Vincent's and Bob's and myself's. We like the people who come here to feel that the sofas are there to sit on, the drinks are there to be poured, the fire to be lit, and that whoever is there standing or sitting or lying down is at home.

Sometimes it is difficult; sometimes I wish to talk to a friend and be alone with him and the bell rings and in walks somebody whom I am delighted to (Continued on page 226)

So much pattern and softness invite you to come right in

"I wanted an apartment that looked American, where everybody could drop in on me, where I would never give a formal dinner party. To achieve what I wanted, I was willing to change things as soon as I found out that I liked something else better," says the Countess Rattazzi of her New York apartment, which has the throwaway quality of a pair of jeans specially tailored for her by a Paris couturier. What "American" meant to her was really a version of English and American country houses where everything is very comfortable, very colorful, with no damasks or silks, no formal rooms in the grand European tradition. Though it is in fact tempting to sit on the floor, the apartment is in no way a slapdash hangout for friends. It is a lavish, no-holds-barred background for an intense, magnetic personality. With architect Page Cross, Countess Rattazzi remodeled the apartment, then with a team of designers—Denning and Fourcade and Mark Hampton, of McMillen Inc.—chose fabrics and changed them—compare sofa fabric on previous pages with that here—tried things one way and then the next in a determined attempt to get it right. Beautifully anchored on a rare antique Persian rug with a blue ground, the living room shown here is upholstered in a padded blue basket print cotton. The rest of the room is a series of warm yellows and peaches in different patterns in needlepoint, cotton, porcelain, and Oriental lacquer. *Below:* Fireplace with a Max Ernst above. *Right:* Looking toward the hallway, life-preserver-shaped pillows stacked on the sofa against the wall, a beautiful Turner above.

HORST







AT SUSANNA RATTAZZI'S *continued*

HORST

Like almost every room in the apartment, the dining room also works as a sitting room. Because Countess Rattazzi thought red was a good eating color, she and Mark Hampton worked out a Venetian red for the walls, had them painted seven times, then lacquered four more. The arches of the doorway are repeated in four old Italian paintings of the Elements. The white ceiling lightens the whole. An Edwardian armoire gets along with suede ottomans, the little television on a green lacquer table. Anything but grand in mood, the dining room adapts easily to buffet suppers.

Left: A view to the back of the room; *top*, to red lacquer sideboard and living room beyond; *above*, looking into the dining room. *Opposite:* The round poker table set for lunch.

Rich color and shine set up for dinner talk

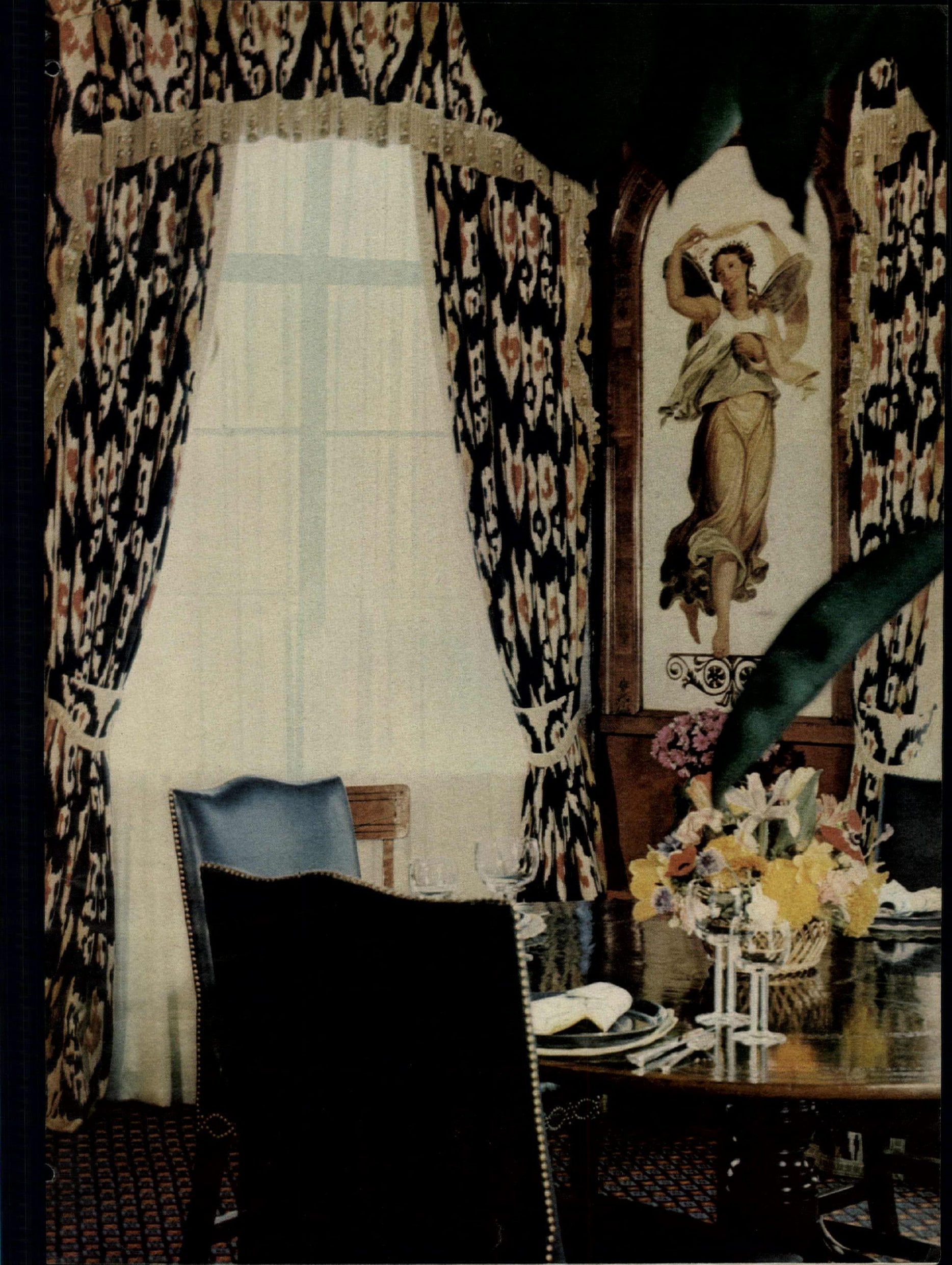





AT SUSANNA RATTAZZI'S *continued*

Like a little pavilion with a fabric-covered dome, Countess Rattazzi's take-off on a grand bedroom has one stunner of a piece of furniture—a massive mahogany and gilt bed made in the nineteenth century, found for her by Denning and Fourcade, placed majestically at an angle in what is basically a tiny room. An intricate African print covers the walls of the hall, and stairway, *above*, still doesn't look murky because of all the white details. Looking into the small library, *below*, one of the arched doorways repeated throughout the apartment. The library that doubles as a guest room, *right*, is built around the blue and brown of the horseman chintz plus book bindings. Its rich padded feeling comes from curtained doorways and shirred walls. The major piece of furniture is an early eighteenth-century red lacquer secretary. Beige, brown, black carpet adds more color, a different pattern; a lacquer coffee table picks up the red, adds shine to a room done in cottons. More white lightens all the blue and brown.

Arched doorways
and a dome turn small
rooms into pavilions



CREATIVE CRAFTS

Over the years since she opened the O'Neil Studio-Workshop in New York, Isabel O'Neil, the internationally known authority on fantasy furniture finishes, has shared with *House & Garden* the secrets of her fabulous techniques of creating with paint the look of bamboo, wood, tortoise, marble, and semiprecious stones. Now, as a bonus for those who have tried her fantasy finishes and as an enticement for those who have not, Mrs. O'Neil has gathered together complete histories and illustrated instructions for every technique she has perfected in her years of study, research, and teaching and put them in one treasure of a book: *The Art of the Painted Finish for Furniture & Decoration*. (A *House & Garden* Book, published in October by William Morrow—\$17.95 until January 1, 1972, then \$19.95. To order, see page 140.)

In the book as in her classes, the most advanced and demand-



ing technique is that of burnished gilding, the Renaissance art of turning furniture into treasure with a hair's-breadth coating of brilliant gold. The process is a painstaking one of floating precious leaf—so fragile (1/250,000ths of an inch thick) that it turns to butterfly dust at a touch—over a specially prepared surface of ivory-smooth gesso and flawless polished clay bole, then burnishing it with agate tools to a deep metallic luster. (Laying the leaf over any other surface produces a softly gleaming matte finish, pale and frosty compared to the ruddy brilliance of burnished leaf. See *House & Garden*, October, 1967.) Burnished gilding requires a sure, delicate hand and Mrs. O'Neil feels a good background in other types of leafing before attempting it, so detailed instructions are not included on these pages but may be found in her new book. The rewards for this patience are exquisite works of art, lavished with the radiance of deathless gold.

AN ISABEL O'NEIL FANTASY FINISH THE ART OF BURNISHED GILDING

Above: At the O'Neil Studio-Workshop, Mrs. O'Neil oversees a group of students during a two-week, eight-hour-a-day intensive course on basic furniture finishes. Students are transferring designs to boxes and mirror frames. Behind Mrs. O'Neil, a wall full of molding samples, each painted a different fantasy finish. *Opposite page:* A sampling of the products of Mrs. O'Neil's graduate gilders. *Clockwise from top:* Butterfly Parsons table with splendid burnished gold and tarnished silver leaf butterflies soaring on a background of silver and tarnished silver leaf. By Mrs. Willis Mills. Mirror frame finished in eggshell inlay, embellished and molded in raised burnished gold. By Mrs. Ramsey Wilson. Tiny burnished silver trunk just 9 inches long, with straps and buckles carved in raised gesso, then covered with burnished gold. By Mrs. Clifford Nellissen. Art Nouveau box with a design in three levels of gesso, plated variously with matte gold, burnished silver, burnished lemon gold, and brilliant burnished gold—12 inches long. By Mrs. Ramsey Wilson. Louis XV coffee table sheathed entirely in matte silver, with a fretwork of 22-carat burnished gold and burnished lemon-gold leaves. By Mrs. Daniel Kampel. "Jewel" studded picture frame of matte gold with gesso gems, borders of burnished gold. By Mrs. Henry Cook.

Beginning students of furniture finishing learn how to prepare the wood, paint, stripe, and antique it the professional way. Besides intensive-study summer courses, Mrs. O'Neil, who has been teaching for fifteen years and worked professionally for interior designers before that, conducts a full-year curriculum of courses, all with their prerequisites, in the various techniques.

BRUCE WEBER



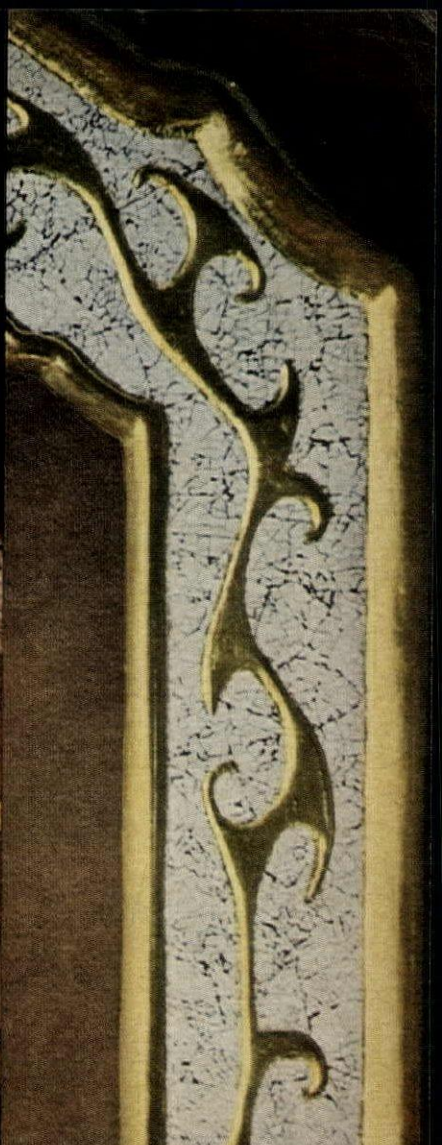



FOR LIVING NOW **A**
HOUSE
NEXT
TO
NATURE

Deep in 20 acres of magnificent woods in New York State, a serene white house, like a clear brush stroke in the wilderness, makes an arrestingly beautiful counterpoint to its site—the crest of a craggy bluff overlooking an old stream-fed quarry. Designed by architects Keith Kroeger and Leonard Perfido of Kroeger-Perfido, the house was painstakingly planned to keep the natural surroundings totally undisturbed and become the chief focus of the design. Every line of the low, flat-topped, white stucco exterior is pared to its essentials—crisp, pure, geometric. Inside, huge glass panels fill each room with the magic of moonlight, flights of birds, a snowfall, and streaming sunshine.

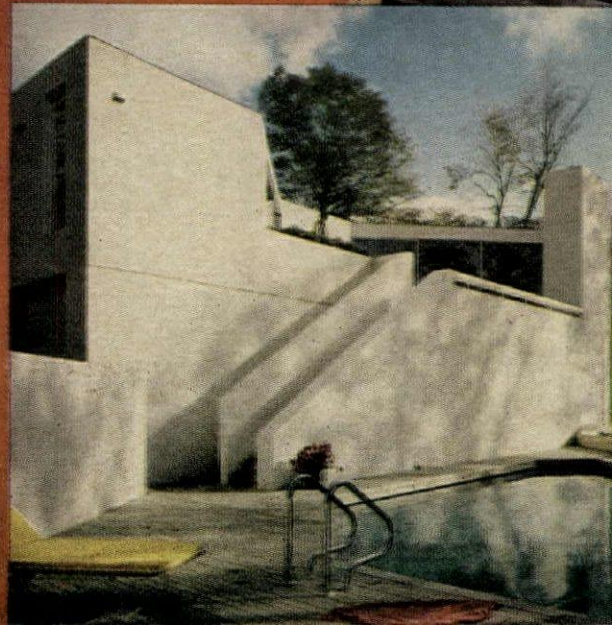
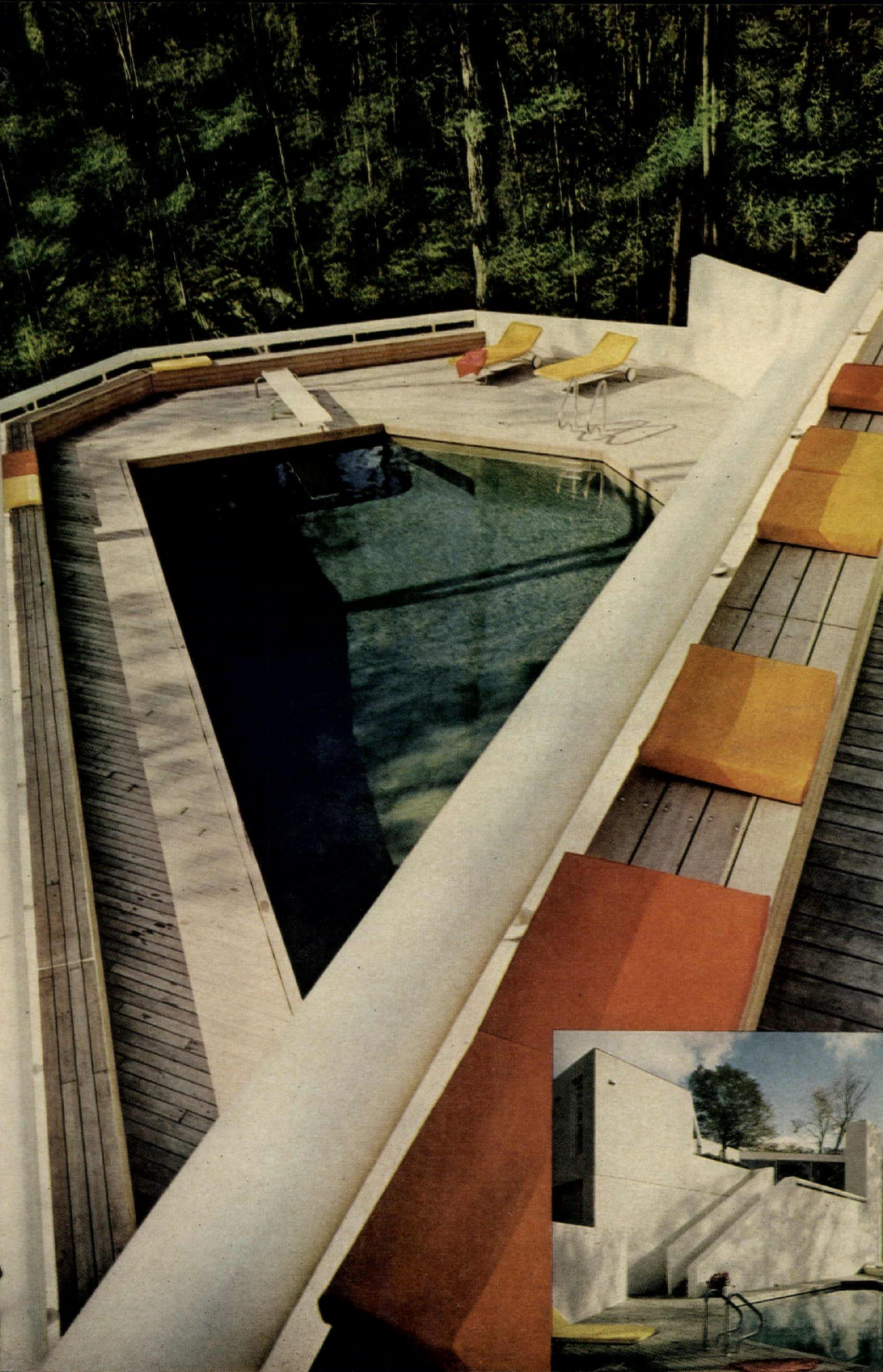

Pudding or Grand Pudding?

The difference is a spoonful of Grand Marnier.

Next time you're making your favorite pudding, try adding a little Grand Marnier. It's fine old cognac mysteriously sweetened with bitter orange. So in one easy step it can take a pudding and make it something right out of a pudding lover's dream.



Grand Marnier

You don't have to be a gourmet to cook like one.

Carillon Importers, Ltd., 745 Fifth Avenue, New York City 10022.
Product of France. Made with fine cognac brandy, 80 proof.
© Carillon Importers, Ltd.

CORKSCREW

Your liquid assets - drinks for parties

EDITOR'S NOTE: *Whether you're hunting inspiration for a party or information on how much champagne you'll need to serve 200, you'll find it in a beautiful brand-new book that takes up every angle of entertaining and puts it all together for you: House & Garden's Complete Guide to Creative Entertaining published by McGraw-Hill. Here we've given you a taste, from the chapter called "Your Liquid Assets," of its fascinating combination of sound basics, tips on logistics, and fresh ideas and recipes. After October 15, you'll be able to buy House & Garden's Complete Guide to Creative Entertaining (\$14.95 until December 31, 1971; \$17.50 thereafter) either at your favorite bookstore or by writing Condé Nast Books, P.O. Box 3308, Grand Central Station, New York, N.Y., 10017.*

Wines and spirits are the liquid assets that make a party pay dividends in fun and pleasure. A palate-provoking apéritif or bone-dry sherry before lunch, a full-bodied red or delicate white wine with dinner can turn a simple meal into an occasion. There's nothing like a well-mixed martini or margarita to stimulate the flow of conversation at the cocktail hour, while to round off an evening with a glow of well being and contentment a fine old Madeira or cognac, a fruit-flavored liqueur or white fruit brandy can't be bettered.

The cardinal rule of successful entertaining is "be innovative." Don't always stick with the same old highballs, the stereotyped cocktail party. Instead, why not give a one-drink party and serve nothing but a selection of champagnes, or dry and medium sherries, or imported beers from all over the world? In summer, a range of white wines with a buffet of cold seafood couched on ice, or pitchers of sangria and dishes of various kinds of olives, salted almonds, and cubes of sharp cheese and Virginia ham make a refreshing change from the usual mixed-drink pattern. In winter you might have an after-dinner gathering for coffee and cognacs, or, if your guests are Scotch fanciers, a tasting of the different blends of light and heavy Scotches and the straight malts, the unblended

Continued on page 135

OPPOSITE PAGE:

Festive food to make for parties and presents

James Beard (see inset) helps students prepare a huge bowl of fruits and suet for traditional Plum Puddings, teaches more holiday dishes (see recipes on following pages) that make super party fare, very special presents. For the giving: Steam Plum Puddings in clear oven-proof soufflé dishes (sized for two), show off Fruit Cake in Pyrex soufflé dish, Brandy Snaps in an Italian Mason jar. Shopping information, page 144.

YAMASHIRO, BEADLE

HOUSE & GARDEN



A LESSON
WITH
JAMES BEARD
FOUR
GREAT
CHRISTMAS
RECIPES

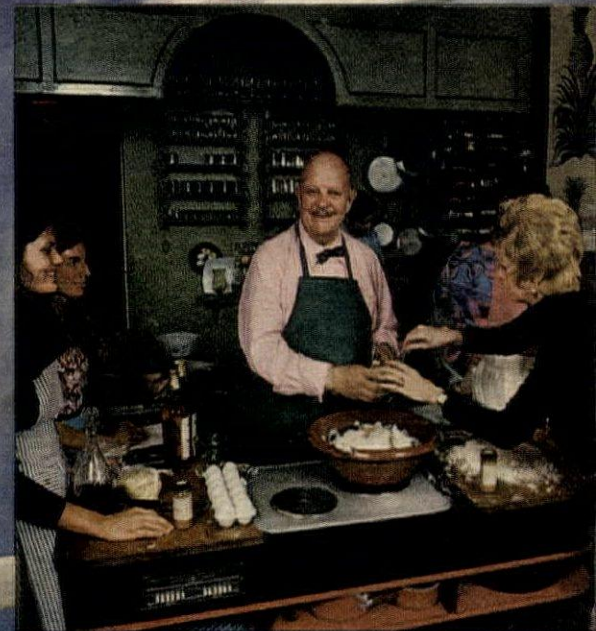

HOUSE & GARDEN VISITS JAMES BEARD'S COOKING CLASSES

Many of the great classics of holiday food must be made at least a month, preferably more, in advance in order to assume their full, rich, Christmas flavors. The time to make them is *now*, and why not make them in large enough amounts so that some can be kept for parties, the rest given as presents? "Keep Plum Puddings anointed with booze," advises Mr. Beard, "and they'll keep perfectly up to six months." Store them wrapped tightly in foil, in or out of the refrigerator. Give them with Cognac Sauce or Brandy Butter, and instructions for reheating. Holiday Fruit Cakes should be made at least a month ahead of time and wrapped in towels soaked in whiskey and then tightly in foil. Mincedmeat also needs aging. Mr. Beard learned this recipe from his mother who often made it a year in advance, aging it in huge crocks—with occasional treats of more brandy—for four months before putting it in jars. Brandy Snaps, unfilled and kept in a closed tin or jar, will keep for a month; once they have been piped with cream, they should be given within a day or two.

PLUM PUDDINGS, FRUIT CAKE, MINCEMEAT, AND BRANDY SNAPS TO MAKE FOR PARTIES AND PRESENTS

Holiday Fruit Cake

Butter

- 1 1/4 cups all-purpose flour
- 1/2 teaspoon baking powder
- 1/2 teaspoon salt
- 1 cup white raisins
- 2 cups finely cut mixed candied fruits
- 1/4 pound candied cherries
- 1/4 pound candied pineapple, cut in small pieces
- 1 cup chopped pecans
- 1/2 cup butter
- 1/2 cup sugar
- 3 eggs
- 10 tablespoons Irish whisky

Making plum puddings and fruit cakes calls for a great deal of chopping: fruits, nuts, suet, etc. Right: A student chops pecans for Holiday Fruit Cakes using a heavy sharp knife; teacher James Beard looks on. Below: Student sifts together flour, baking powder, and salt before adding to the bowl of candied fruits and raisins for the cake.

Butter well 2 9-by-4-inch loaf pans and line with waxed paper. Butter paper. Sift together the flour, baking powder, and salt. Mix in the raisins, candied fruits, and pecans. Cream the butter and sugar until light and fluffy. Beat in the eggs, one at a time. Combine with the fruit and flour mixture. Stir in 2 tablespoons Irish whisky. Pour into the pans and bake in a 300° oven for 1 1/2 to 2 hours, or until cake tests done. Cool and anoint with remaining whisky. Wrap in foil to store.



Pans for baking fruit cakes must be buttered and lined with buttered paper. To give as presents, use disposable foil pans or oven-proof clear glass soufflé dishes. Below, a student fills pans to within 3/4 inch of the top of container.

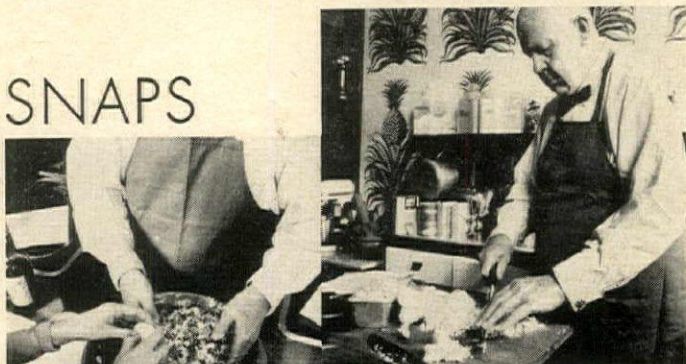

Making Christmas puddings is robust entertainment. The largest bowl possible is used to mix ingredients, and everyone in the family—this time, the class—stirs the mixture for luck, above. James Beard, above right, chops beef kidney fat (suet) finely. Pudding can be steamed in anything from a coffee can to a copper kugelhopf pan, right.

Christmas Puddings

- 2 pounds seedless raisins
- 2 pounds currants
- 2 pounds sultana raisins
- 4 tart apples, peeled and finely chopped
- 3/4 pound mixed candied peel, finely cut
- 2 pounds beef suet, finely chopped
- 3 cups flour
- 1/2 pound blanched almonds, chopped
- 3-4 cups fresh fine bread crumbs
- 1 teaspoon each cinnamon, nutmeg, and mace
- 1/2 teaspoon ground cloves
- 2 teaspoons salt
- Juice and grated zest of 3 lemons
- Cognac
- Rum or Grand Marnier
- 12 eggs, well beaten
- Beer (optional)



Combine raisins, currants, sultana raisins, apples, and mixed peel in a large bowl. Toss suet with some flour, stir into fruit mixture with remaining flour, almonds, bread crumbs, spices, salt. Mix well with hands. Add lemon zest, juice, 1 cup cognac, 1 cup rum or Grand Marnier, and eggs.

Mix well. If there is not enough liquid, add more cognac, or beer. Mixture should be well bound together. Cover mixture with foil, let stand 24 hours. Sample and correct to your own taste. Fill pudding basins with mixture, leaving room for expansion. Cover with foil and tie scalded, floured cloths around them. Or use pudding molds with tight-fitting covers.

Place basins or molds on a rack in a deep saucepan or ket-

Continued on page 134

BEADLE

Just because ice cream was your first love, doesn't mean it has to be your only love.



Remember how you and Johnny
(or was it Joey?) used to go gaga
over Pop's homemade ice cream down
at the candy store?

Remember the time you both ate
half the cherry?

It was only yesterday. Not too many
chocolate dreams ago.

Now, you can introduce your tongue
to a new love. A mature love. A richness
and smoothness of pudding, a coldness and
creaminess of ice cream.

Cool 'n Creamy® pudding. From
Birds Eye®. Cool 'n Creamy vanilla.
Dark chocolate. Light chocolate.

Chocolate café.
Butterscotch.

Lemon crème.

All ready to come out
of the frozen food section of
your friendly neighborhood
supermarket and into your

refrigerator.

Ready to stand proud
and tall. Unfrozen.

Waiting.

Ready to satisfy
the sweet tooth of
those you love.



Cool 'n Creamy. The best thing since ice cream.



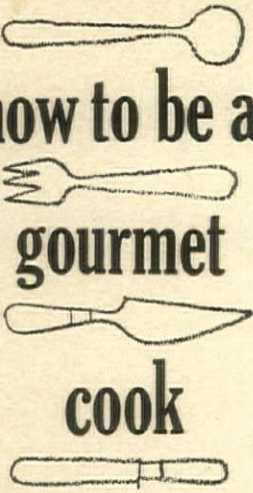

how to be a gourmet cook the easy way

Just follow the *delectable* recipes published monthly in House & Garden's gourmet Cook Book sections. Detachable, they can be filed for quick reference in H&G's handsome new binder. Binders \$2.00 each.

To:
House & Garden Cook Books
Dept. 10-71, P. O. Box 1910
Grand Central Station
New York, N. Y. 10017

Please send the following:

_____ Binders @ \$2.00....\$ _____

_____ Cook Book Inserts

(Checked Below) @ \$.25 _____

(Postage & Handling)....\$.25 _____

Total amount enclosed....\$ _____

Please make check or money order payable to HOUSE & GARDEN

- 48 Omelette
- 50 Quick Mix
- 56 Buffet
- 57 Ham
- 58 Bean & Lentil
- 65 Sandwich
- 67 Chinese: Part II
- 68 At-the-Table
- 70 Short Cut
- 72 Rice & Grain
- 73 Seasoning
- 74 French
- 76 Washington
- 77 Pickles & Preserves
- 81 Party
- 82 In A Pot
- 83 Middle East
- 84 Egg
- 85 Sausage
- 92 Master Menu
- 93 Pudding & Pie
- 94 Pot Roast
- 97 Frozen Foods
- 124 Cook Book for Epicures in the Arts
- 125 Mushroom Cook Book
- 126 Pate Cook Book

NAME _____

ADDRESS _____

CITY _____

STATE _____ ZIP CODE _____

Allow 3 weeks for delivery.

JAMES BEARD CHRISTMAS RECIPES

tle and add water to come half-way up the mold. Cover and boil puddings 6 to 8 hours, according to size, replenishing water if it boils away. Remove and cool. When cool, uncover, pour a glassful of cognac or rum over each, cover again, and leave in a cool place for a few weeks or months, the longer the better. You may wish to add more cognac or other spirit while they are ripening.

Before serving, the puddings will need reheating in boiling water in their molds, for 2 to 3 hours. Unmold on a hot dish and flame with $\frac{1}{2}$ cup heated cognac. Serve with Cognac Sauce or Hard Sauce or both. Makes about 5 1-quart puddings.

Cognac Sauce or Brandy Butter

Whip $\frac{3}{4}$ cup unsalted butter to a cream, gradually beat in $\frac{1}{4}$ cup confectioners sugar, and continue beating while adding $\frac{1}{4}$ cup cognac. Beat until very light. Serve cold.

Hard Sauce

Cream $\frac{1}{2}$ cup unsalted butter with 1 cup sugar. Beat until light and perfectly mixed, then add kirsch to taste and a small amount of salt.

Mincemeat

A family recipe James Beard learned from his mother.

- 3 pounds lean brisket or rump of beef
- 1 fresh tongue, about 3 pounds
- 1 $\frac{1}{2}$ pounds beef suet, finely chopped
- 2 pounds seeded raisins
- 2 pounds sultana raisins
- 2 pounds currants
- $\frac{1}{2}$ pound citron, shredded and diced
- $\frac{1}{4}$ pound orange peel, shredded and diced
- $\frac{1}{4}$ pound lemon peel, shredded and diced
- Dried figs or dates, optional

- 2 cups sugar
- 1 pint strawberry preserves
- 1 tablespoon salt
- 2 teaspoons nutmeg
- 2 $\frac{1}{2}$ teaspoons cinnamon
- 1 teaspoon allspice
- 1 teaspoon mace
- Ground cloves
- 1 bottle ($\frac{1}{5}$ quart) good sherry Cognac

Boil the brisket or rump and tongue in water until tender. Cool the meat in the broth, skim off the fat, remove all fat from the meat, and grind it coarsely or chop it by hand. Combine with the suet, raisins, sultanas, currants, citron, orange peel, lemon peel, and some chopped dried figs or dates, if you wish. Put this in a deep crock and add the sugar, strawberry preserves, salt, nutmeg, cinnamon, allspice, mace, and a little ground cloves. Add the sherry and enough cognac to make a rather loose mixture of the fruits and meats—it will take about 2 bottles. Mix thoroughly, cover the crock, and let the mincemeat stand for at least a month before using it. Check each week to see if the absorption makes it necessary to add more sherry or cognac or both.

Ways to use mincemeat

Mincemeat, of course, can always be used for the traditional pie, but Mr. Beard also suggests these imaginative uses for it:

Make a **deep-dish tart** of layers of sliced apples and mincemeat, topped with either a crisp, flaky pastry or a streusel topping.

Use mincemeat in a **frozen mousse**, folding the mincemeat into the basic mousse combination of sugar syrup, egg yolks, beaten egg whites, and whipped cream.

Mincemeat is a **delicious filling** for little double-header cookies, or tiny little turnovers served hot for tea.

Heat mincemeat, flame it, and **pour over ice cream.**

Add more cognac, heat it, and serve mincemeat as an **accompaniment to pork, goose, or duck.**

To make mincemeat pie, mix 2 $\frac{1}{2}$ cups mincemeat with 1 cup finely chopped apple. Put into a 9-inch pie plate lined with rich pastry dough. Top with pastry.

Brandy Snaps

- 8 tablespoons butter
- $\frac{1}{4}$ cup confectioners sugar
- 5 teaspoons light corn syrup
- 1 teaspoon molasses
- $\frac{1}{2}$ cup flour
- $\frac{1}{2}$ teaspoon ground ginger
- $\frac{1}{4}$ cup brandy
- Butter
- 1 $\frac{1}{2}$ cups heavy cream, whipped and flavored with $\frac{1}{4}$ cup confectioners sugar and 2 tablespoons brandy

Bring the butter, sugar, corn syrup, and molasses to a boil in a heavy skillet over medium heat, stirring until butter melts and sugar dissolves. Remove from heat. Gradually beat in the flour, ground ginger, and brandy. Beat over low heat until smooth. If mixture is thick, thin with a little brandy. Drop batter by teaspoons onto a buttered cookie sheet, about 4 inches apart, and flatten slightly with a spatula. Bake in the middle of a 350° oven for 8-10 minutes, or until cookies have spread out and turned golden brown. Turn off heat and leave sheet in oven. Working quickly, remove one cookie at a time with a metal spatula and quickly roll it while still warm around the buttered handle of a wooden spoon. When all are rolled, pipe the flavored whipped cream into each end. Makes about 15 3 $\frac{1}{2}$ to 4 inch brandy snaps.

whiskeys now on the market that are so different in flavor and character. Then, of course, there is the wine-tasting party, which has grown in popularity over the last ten years, especially with young marrieds who find this an entertaining, economical, and rewarding way of spending the evening with a group of friends while increasing their knowledge of the different types of wines.

You don't need an extensive or expensive bar or wine cellar in order to give good parties, just a willingness to experiment a little.

STAGING A WINE TASTING

While it would take a lifetime to make the acquaintance of all the wines of the world, you can get to know more of them, and more about them, by staging a series of wine-tasting parties with a group of friends. In this way, you can sample as many as eight different wines in a single evening without over-indulging or over-spending, for naturally you will all share in the cost of the wine tasting.

Don't try to taste a whole bunch of different wines, stick to those from one country or one area of a country that produces a great many wines. Wine tasting is for purposes of comparison, to judge the product of one chateau against another, or the white wines of the Rhine and Moselle against those of Alsace. So have an all-Bordeaux or all-Burgundy tasting, a group of representative whites and reds from Italy or Switzerland, eight wines from different wineries in Cal-

ifornia or New York State. Furnish your guests with pads and pencils so they can jot down their reactions and, after the tasting, offer coffee and cognac, to be sipped while everyone comments and compares notes.

To set up your wine tasting, space out the bottles in the order of tasting on a large table covered with a white cloth. Put the whites first, starting with the light and brisk and going on to the richer and fuller. Follow with the reds, beginning with the lightest and least important and progressing to the greater. If you want to include champagnes, have them first or last. Then group the glasses in front of the bottles. The best glass for wine tasting is the large-bowled, all-purpose wine glass, which allows the taster to swirl the wine around and get the full fragrance of the bouquet. This glass will also serve for sparkling wines, but the long slim flutes that hold the bubbles are pleasanter to sip from. You do not have to provide a separate glass for each wine, although it is nice to have two glasses per person if you are tasting both whites and reds. Instead, place several rinse bowls of water on the table so that the tasters can rinse their glasses after each wine. If this idea does not appeal to you, you can always borrow extra glasses from your wine-drinking friends, or even rent them for the evening. Provide something to clear the palate between wines—cubes of a mild cheese like Gruyère or Cheddar, and pieces of French bread, breadsticks, or plain unsalted crackers are best. Cheese does not help the flavor of white wines, but is excellent for reds.

Continued on the next page

How to cook for a man

He tells everyone what a great cook you are. And you love to hear him say it. But coming up with something new and different seven nights a week isn't exactly easy. That's where Birds Eye® can help. With recipe ideas that make life easier.

Carrots with Brown Sugar Glaze.

While the carrots simmer, broil a

Hamlet. Cook 1 package of Birds Eye One of 18 Birds Eye Combination Vegetables. 1 1/2 pound ready to eat ham slice, about 1/2 inch thick. After 7 minutes, turn the ham and spread the top with a teaspoon of prepared mustard. Then whisk it back under the broiler for another 5 minutes. Now top with the cooked carrots. And call him to dinner. Wasn't that easy?

Serves 3

"Meals to Please a Man" is a free booklet of other recipes like Hamlet. Just send your name, address, zip code, and one side panel from any Birds Eye Combination to: Box 1010, Kankakee, Ill. 60901.





GERBER
Legendary
BLADES

Let your love show

Gerber blades become part of proud family tradition to be used, cherished and handed down to succeeding generations. When you select a gift of Gerber blades your love shows.

A gift of Gerber blades is no ordinary gift. Not by quite a bit. The design is classic. Uncluttered. Harmonizes with any silverware pattern. Cutting edges are super sharp and stay that way through

repeated use because the blades are crafted from Gerber's exclusive high speed tool steel known as the steel that cuts other steel.

There are more than a dozen blade styles to choose from, available individually or in a wide selection of distinguished sets for carving, dining and kitchen use.

At fine silverware, cutlery and gift shops everywhere.

Write for free folder.

GERBER LEGENDARY BLADES/PORTLAND, OREGON 97223



PomonaStone

TILE SHOWN: 9 X 9 FAENZA LOW RELIEF, SABLE COLOR

It's a brand new era in all-tile design . . . with PomonaStone! The age of innovation . . . combining five rippling textures, seven earthy colors, two low-relief patterns and a sophisticated hexagon shape. The age of convenience . . . the whisk of a damp mop restores permanent elegance. PomonaStone . . . the age of creative fashion in ceramic tile.

For colorful brochure, send your name, address and 10¢ to:

Pomona Tile 

A DIVISION OF AMERICAN OLEAN

P.O. BOX 2249 • DEPT. HG-1 • POMONA, CALIF. 91766

PARTY DRINKS *continued from preceding page*

Temperature is important if you are to get the most from a wine. Bring the reds to the room where they will be served several hours ahead of time and remove the corks an hour before the tasting. When you uncork the bottles, place the corks beside them. True connoisseurs like to sniff the cork to get an idea of the condition and bouquet of the wine. White and sparkling wines should be chilled but not too icy or they will lose their flavor and taste flat. Push the bottles into wine coolers or buckets filled with ice and chill about fifteen minutes, turning occasionally to cool evenly. Or chill them in the refrigerator for two hours.

There are three things to note about a wine: color, bouquet, and taste. Pour 1½ to 2 ounces of wine into the glass (you don't have to measure, just estimate by the eye) and hold it up to the light. Is the color clear and brilliant or dull? Then roll the wine around in the glass, put your nose in the glass and sniff deeply. Does the wine have a delicate bouquet, a rich fragrance, or none at all? If the wine was made from one of the great grape varieties such as Pinot Chardonnay or Cabernet Sauvignon from which white Burgundies and red Bordeaux are made, can you detect the characteristic fragrance of the grape? Now take a sip and roll it around your mouth and over your tongue where it will come into contact with your taste buds. If you can, suck air through your lips and let it swirl through the wine, a professional's trick that points up the flavor. Finally, swallow slowly, carefully noting the body, the smoothness of the wine and the aftertaste, if any. Did the wine have a light rippling feeling in your mouth and throat, or was it round and full-bodied? Was it thin and watery? Did it have a smooth quality or was it harsh? How was the flavor—subtle or direct, delicate or rich? If the wine had an aftertaste, was it pleasing or unpleasing? When tasting white wines, consider whether the wine was flowery and a little sweet or dry, even flinty dry. Was it light, round, or full? Remember, you are tasting for yourself, in order to find a wine you might like to drink regularly. So do not be influenced by the opinions of the other tasters. The best wine for you is the one you like best.

DRINKS FOR CHAMPAGNE PARTIES

If you are feeling liberal, there's really nothing better than a champagne party, and provided you serve a good American champagne or a nonvintage French champagne, it really runs you little more than the cost of a cocktail party—and you don't have all the bother of providing lots of bottles and mixing drinks all evening. Or you may prefer to serve champagne as an apéritif before a very fine dinner, as the real wine connoisseurs do, or with just one course of the meal. A bottle of champagne goes further and fares better if it is served with a first course of caviar, smoked salmon, oysters and other shellfish, or pâté: or as an accompaniment to a main course of roast pork or ham, cold pheasant or quail, all of which welcome its fine, dry acidity. Even little hot sausages and *choucroute garni*, definitely bourgeois dishes, are quite at home with this aristocratic wine, so perfect with any kind of pork. And like most aristocrats, it goes on a picnic with perfect aplomb—

Continued on page 138

This Magic Chef cooks everything at once

(IN TWO CONTINUOUS-CLEAN OVENS)

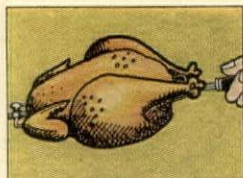

Rotisserie. In upper oven.

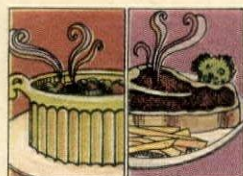

Two complete ovens. With separate thermostats. Bake and broil on both levels.

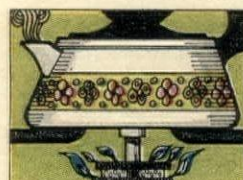

Pot watcher. Thermostatic burner prevents boilovers.



Smokeless broiler. In lower and upper ovens.

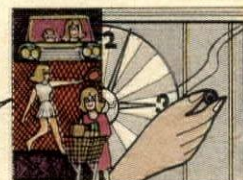
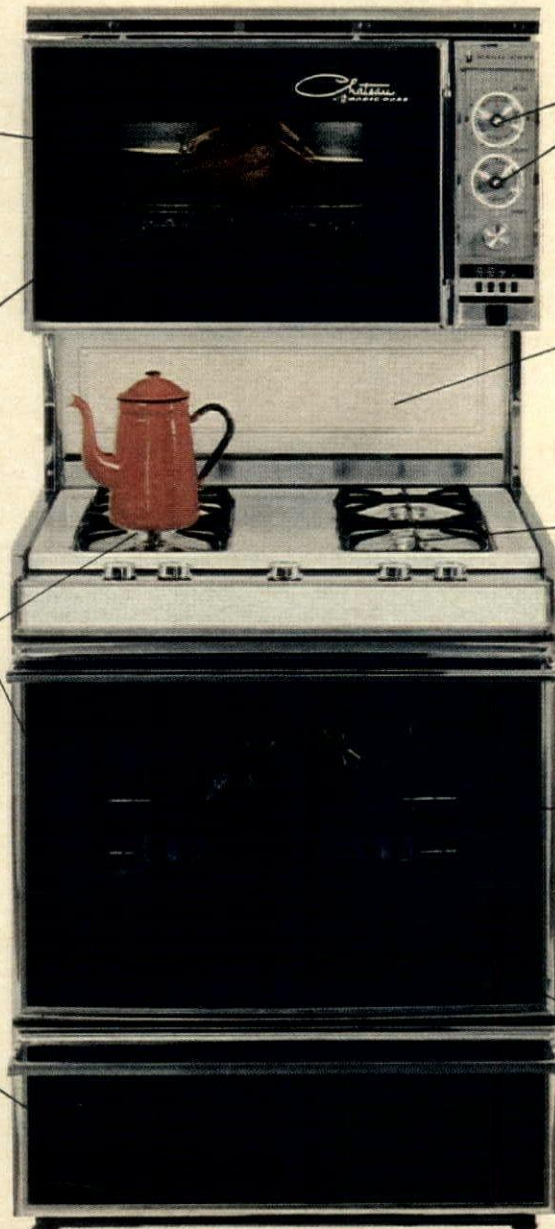

Cook and Keep Warm. Automatically. Holds dinner at a gentle 170°



Fluorescent cooktop light.

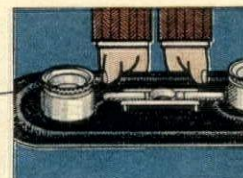

Uniburner. The space-age burner. Better flame control than other gas burners. Even has a built-in drip tray. Removable.



Low-heat oven control. Keeps meals warm without drying.

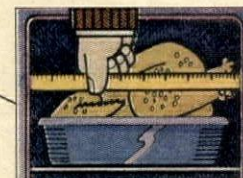

Big 25-inch-wide oven. Large enough for your biggest roaster.

This Magic Chef cooks everything in one place

(IN A CONTINUOUS-CLEAN OVEN)



Magic Chef has lots more conveniences that your old range doesn't have. Including waist-level radiant broiling. Removable oven door and door seals. Lift-up and lift-off cooktop. Continuous-Clean oven and oven door panels.

Ideas your mother never dreamed of.



Magic Chef.

This Magic Chef even has a griddle in the middle

(AND A CONTINUOUS-CLEAN OVEN)



the Edwardian fashion of feasting on a cold bird and a bottle of bubbly has yet to be bettered for eating outdoors.

If you would rather serve a champagne punch, which has the merit of stretching the supply when you have a huge guest list, there are various types from which you can choose, some rather more alcoholic than others. Here are three excellent ones.

Champagne-Sherbet Punch. Combine 3 bottles well-chilled dry champagne and 1 quart lemon, raspberry, strawberry, or cassis sherbet in a well-chilled silver or crystal punch bowl. Garnish with fruit: with lemon sherbet, lemon and orange slices; for raspberry, a few strawberries; for strawberry or cassis, strawberries and orange slices. The sherbet should be icy cold, but not frozen into a hard block or it will not blend. Serve in punch cups. This makes about 30-35 servings.

Champagne-Orange Punch. Combine 2 quarts orange sherbet or 3 to 4 undiluted cans frozen orange juice concentrate, 3 bottles well-chilled champagne, and 1 cup chilled Grand Marnier in an ice-cold punch bowl. Garnish with orange slices. Makes about 40 servings. If you use the frozen orange juice concentrate, you may need an extra bottle of champagne. For a brisker drink, you can add lemon or lime juice concentrate to taste, and for a more alcoholic one, add more Grand Marnier and a cup of cognac.

Champagne-Cognac Punch. Cut the peel from 2 lemons and 1 orange in long thin spirals with a sharp paring knife or the gadget called a stripper. Place in a chilled punch bowl with a large block of ice. Add 1/2 cup sugar, 1 bottle cognac, 2 cups water, and a good dash of Angostura bitters. Blend well and, just before serving, add 4 bottles chilled champagne, either extra dry or brut. Makes about 35-40 servings.

DRINKS FOR BIG PARTIES

For parties on a grand scale where you may want to serve a stronger drink, choose a punch with a spirit base—cognac, rum, whiskey. Some of the best, such as Fish House punch and Artillery punch, contain tea and, to guard against the weakening of the punch by melting ice, freeze the tea, which is nonalcoholic, into a block and use this as the chiller. (Don't try freezing anything containing wines and spirits though, or you'll end up with nothing but a liquid mess.) Select your punch and make a complete analysis of the ingredients some days before the party. Make up a batch of the essential liquors and flavorings and then try out some of this batch, adding the perishable and dilutive ingredients (tea, fruit juices, fruit) to see if they blend properly. If all seems well, mix several large pitchers of the basic spine of the punch and other pitchers containing the other ingredients and keep them all cold,

Continued on page 151

Ronson Cook'n'Stir... the only blender that heats!

It also does everything other blenders do, and does it better. It stirs, whips, chops. It even crushes ice!



WIDE-MOUTH DESIGN. Takes whole fruits and vegetables without pre-slicing. Easy-pour spout.



EXTRA-LARGE BLADES. With bigger base, there's room for bigger blades—driven by Ronson's extra-powerful 1/3 HP motor.

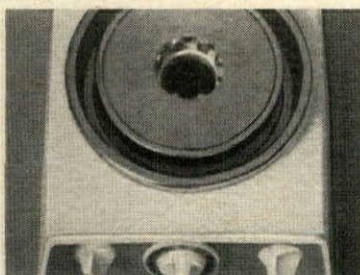

HEATING ELEMENT. Only blender with a heating element. Heats quickly and evenly.



CRUSHES ICE. Drop in whole cubes, set blender on "Cold"; ice is crushed in seconds.

HEAT ON INDICATOR LIGHT. Lights when Hot/Cold selector knob is turned to "Hot."

HOT/COLD SELECTOR. Turn to "Hot" for cooking heat; to "Cold" for regular blending operation.

TEMPERATURE INDICATOR LIGHT. Lights up when contents of blender carafe reach selected temperature.

TEMPERATURE SELECTOR. Thermostatically controlled to hold constant, correct temperature at any setting from "room" temperature to 375°.

SELECTOR FOR STIR RANGE/BLEND RANGE. Selects either stir or blend speed ranges.

PUSHBUTTON CONTROLS. Modern, convenient pushbuttons make speed selection simple and sure.

TEN SPEEDS. Speed ranges from 1 to 5 in Stir Range and 1 to 5 in Blend Range for a total of 10 speeds.

EXTRA-POWERFUL 1/3 HP MOTOR. Powered to blend or stir at any speed, without stalling. Blends whole vegetables, even crushes ice.

RONSON
DIFFERENT BY DESIGN AND BETTER BECAUSE OF IT



"Success Story" is offbeat, kinky and uncommonly lush. It's a new, thick, sexy, plush carpet of Kodel® polyester. The tufts are many, fat and springy . . . to make the carpet comfortable and your fun uninhibited.

Carpets for people to live on.



KODEL
POLYESTER FIBER

AT
\$2.25 A
CAN,
POPPYCOCK
ISN'T
PEANUTS.

Au contraire!
Poppycock is an ambrosial agglomeration of toothsome pecans, toasted whole meaty almonds and fluffy puffs of popcorn—all enveloped in a wicked caramel crunch derived from scads of Grade AA 93 score butter.

Of course, Poppycock isn't exactly peanuts. But then, if it were, it wouldn't be Poppycock.

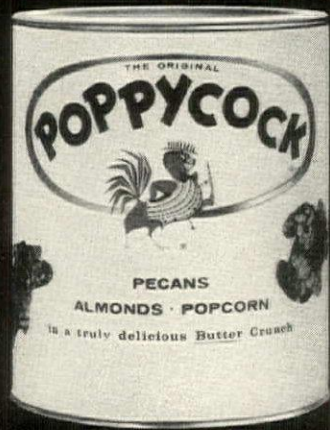

From Villa Park, Illinois, to gourmet food sections, to you.

THE LOVELIEST ROOMS *continued from page 44*

After dinner we returned to the staircase landing where the stairs divided and swept up on each side to two galleries, edged in fine balustrades and surmounted by high open arches, all of the pale rose marble. As we seated ourselves in one of the galleries for coffee and liqueurs joined by other guests invited for after dinner, there appeared in the gallery opposite us the company from the Opéra Comique in splendid eighteenth-century costumes. Even now, after so many years, I can close my eyes and see that picture lit by hundreds of candles and hear Muratore singing arias from *Manon*.

SKILLFUL ENVIRONMENTALIST

A wise woman knows that a becoming background is as important for her as a proper setting for a fine jewel. And no one knew how to set her stage more effectively than Lady Lavery, the former Hazel Martyn of Chicago and wife of the well-known portrait painter Sir John Lavery. She had a delightful house in London and was one of the brilliant and sophisticated hostesses of the pre-World-War-I period.

Houses have atmospheres—all houses—but some are more easily felt than others. Houses can be malicious, too, and Hazel's really was just that, whether or not by her conscious connivance, who can say? Yet it was a work of art, skillfully carried out to make her appear at her very glamorous best. If by so doing, it happened to make her average English guests look washed out and insignificant, that probably did not greatly upset her.

We went there for tea on a hot summer afternoon. When we entered the drawing room she had stepped out for a moment. The room was stunning and exotic. It was the year the Russian ballet had created a great vogue for Russian décor, and the walls were covered with that superb gold lamé of theirs that never tarnished. Hazel had had it dampened and wrung lengthwise into thousands of long wrinkles. When applied to the walls it was not stretched tight but left loose enough so that those lines gave a coruscated texture and a lovely dancing gleam. One great bank of windows was hung in flame shot taffeta, unlined, falling out onto the floor in lavish folds. The furniture was pale green Venetian lacquer. Across the sofa corners hung long limp cushions in every tone of lamé, gold, and silver shot with green, flame, mauve.

Now in those far off days it was the fashion to wear organdies and embroidered muslins and chiffons in faint pinks, sky blue, or white and wide, flower-laden hats. I had just arrived from Paris and my gown was a miracle of hand tucks and Valenciennes ruchings of shell pink with a wide Nattier blue sash. Roses and blue streamers adorned my great leghorn hat. The other women in the room were in similar costumes, dainty and feminine and summery. And what that cruel room did to us.

When Hazel returned with her pointed white face, her large dark eyes, and her delicate slim figure, she was wearing an intriguing frock of black tulle over pale pink. It was difficult to say where the gown left off and Hazel began. She sank onto a sofa—her red curls framed in an immense halo of black tulle against the crinkled golden wall. A ravishing and arresting picture. But after more than fifty years, I have not quite forgiven her for spoiling my best Paris costume.

Continued on page 142

THE ART OF THE PAINTED FINISH FOR FURNITURE AND DECORATION

by Isabel O'Neil



The only modern book ever written about the painted finish and a complete course that takes the reader through many levels of skill to the creation of breathtakingly beautiful finishes. A realistic and practical use is made of modern tools and materials, and even a rank amateur can follow the explicit, step-by-step instructions.

382 pages, 38 color plates.
\$17.95 through December 31st, 1971; \$19.95 thereafter.

HG1071

Mail to
Condé Nast Books, P.O. Box 3308
Grand Central Station
New York, N.Y. 10017

Please send me _____ copy(ies) of THE ART OF THE PAINTED FINISH, postpaid, for which I enclose payment of \$17.95 (offer good until 1/1/72) per copy,

check money order

If, for any reason, I am not delighted, I may return the book(s) within five days and my payment will be refunded at once.

NAME _____
ADDRESS _____
CITY _____
STATE _____ ZIP _____

Spare the rod and you can spoil the whole beguiling effect... of even the finest draperies. That's why we put so much care into our traverse rods. Patented, heavy-duty features that assure long-life. Silent-smooth glide. Happier hang-ups. Working beautifully behind the scenes, or proudly on display as in our sculptured-end, fluted-length decorative lines.

Graber rods. For every modern or traditional window fashion fancy you favor. Get your copy of the new, full-color, excitingly illustrated, 36-page book, "How To Create Your Own Beautiful Window Fashions", only \$1. At any Graber dealer, or write: Graber Company, Graber Plaza, Middleton, Wis. 53562. In Canada, Graber of Canada, Toronto.

fashion hangs on traverse rods by graber.

Graber
DRAPERY RODS
WINDOW SHADES

The Window Fashion People



A CONSOLIDATED FOODS COMPANY • RESPONSIVE TO CONSUMER NEEDS

Have you ever tried giving new life to an old child?

Luis is a nine-year-old who never had a childhood!

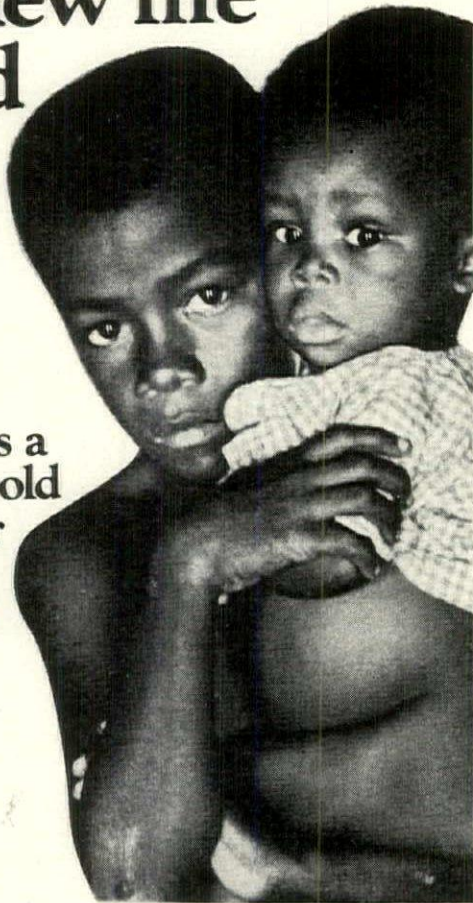

There are many children like him, grown old before their time. Stunted by hunger, numbed by the harsh life in the barrios and slums of South America and Asia.

Imagine! Children who don't know what it is to have enough to eat, who have never seen a doctor or the inside of a school. Malnutrition. Disease. Poverty. It can age anyone before his time.

By becoming a Foster Parent you can give a new life to one of these old children. You can help bring food, clothing, medical care and hope to families the world has overlooked. You can bring the Luises of the world laughter... perhaps even a toy to play with. You can help his family to help themselves. For just \$16.00 a month you can work a miracle! Won't you make room in your heart for one more? Send a gift of life and love... and give a child back his childhood.

FOSTER PARENTS PLAN, INC.

352 Park Avenue South, New York, New York 10010

I want to be a Foster Parent for a year or more of a boy _____ girl _____ age _____ country _____ Where the need is greatest _____

I enclose my first payment of: \$16.00 Monthly _____ \$48.00 Quarterly _____ \$96.00 Semi-annually _____ \$192 Annually _____

I can't become a Foster Parent right now but I enclose my contribution of \$ _____

_____ Please send me more information.

Name _____

Address _____ Date _____

City _____

State _____ Zip _____

PLAN operates in Bolivia, Brazil, Colombia, Ecuador, Peru, Indonesia, Republic of Korea, the Philippines, and Viet Nam. PLAN is registered with the U.S. State Department Advisory Committee on Voluntary Foreign Aid. Contributions are tax deductible.

In Canada, write 153 St. Clair Ave. West, Toronto 7, Ontario HG-4-101

THE LOVELIEST ROOMS *continued from page 140*

BACKDROP FOR CAMILLE

In Lake Forest, Ill., in a house designed by architect David Adler and decorated by his sister, Frances Adler Elkins, is one of the most exquisite bedrooms I know. Luckily it is a guest room, for no average woman could live up to it every night of her life. She could not go to bed with her hair in rollers or cold cream on her face, and even our very best "visiting" nighties would hardly be adequate in surroundings of such delicate subtlety and frail beauty.

The walls are of tarnished silver leaf and most of the furniture, too. Beside the fireplace with its marble mantel are a pair of wing chairs covered in plain white needlepoint. On the dark floor lie three rugs of finest silk petit point from a palace in Czarist St. Petersburg—soft pastel designs on straw yellow. But it is the beds that are so unusual and of such incredible distinction. Mrs. Elkins found four ivory bedposts banded in silver that had been made in India for one of the high British officials. These she used as foot-posts for the two beds. The rest of the beds—headboards, canopies, spreads—are ivory linen covered with ivory Queen Anne needlework of museum quality and value. In the corner between the windows is a chaise longue covered in off-white dull silk. Across the foot an ermine coverlet is folded, and pillows of old lace are heaped at the head. Lights shine softly through great chunks of rock crystal lying on the tables and commodes. Lilies and stock in bowls of the same crystal perfume the tranquil air.

To me this is the setting for the last scene of a Camille-like romance. I see a lovely woman, no longer in her first youth, but imperishably alluring, reclining in that chaise longue in a tea gown of ivory velvet banded in sable. Beside her kneels her lover, holding her frail hands in a last desperate clasp. She dies, beautifully but inevitably, as the curtain slowly descends.

EXPERT WITH PATTERN *continued from page 16*

Your eye will tell you what will work

Then study the paintings of Vuillard, with their innumerable patterns in simple, often somber, colors. Or the work of Matisse, the master of brilliantly colored pattern. Let your eyes evaluate, and learn to distinguish good pattern combinations from bad. You will begin to get the idea. An Indian necklace will suddenly seem tacky on a solid colored dress, and wildly beautiful on a patterned one—the way it was intended to be worn. You will discover a painting takes on new vitality when hung on a wallpapered wall.

When you walk into a room and one of the patterns strikes your eyes before the others, you will realize instinctively that it doesn't belong there. But you will set a vase of flowers on a table covered with a flowered cloth against a flowered wall, and the three elements, almost insignificant by themselves, will become a unified whole with incredible beauty. Great blends of pattern, like great dishes, must be often and carefully tasted. And constant tasting is what teaches a cook how to taste.

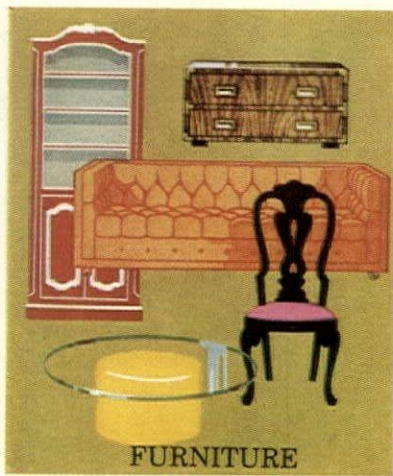

FURNITURE

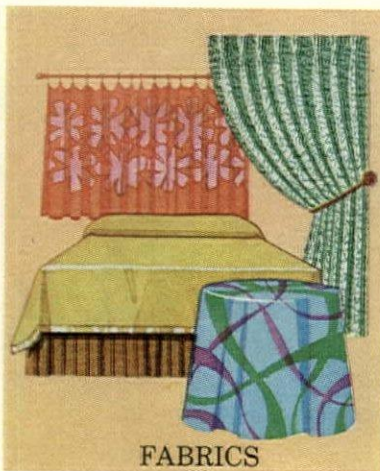

FABRICS

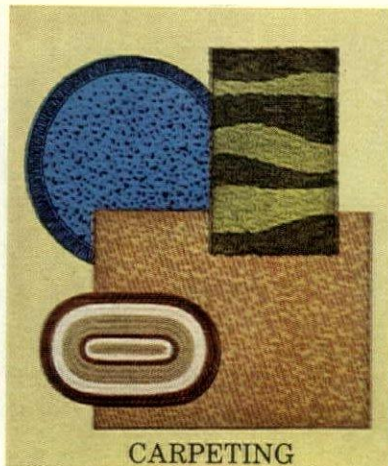

CARPETING



ACCESSORIES

Tru-Test pulls them all together

A rich, wash 'n wear latex in 1,116 luxurious colors to help you transform any room into a decorator's dream.

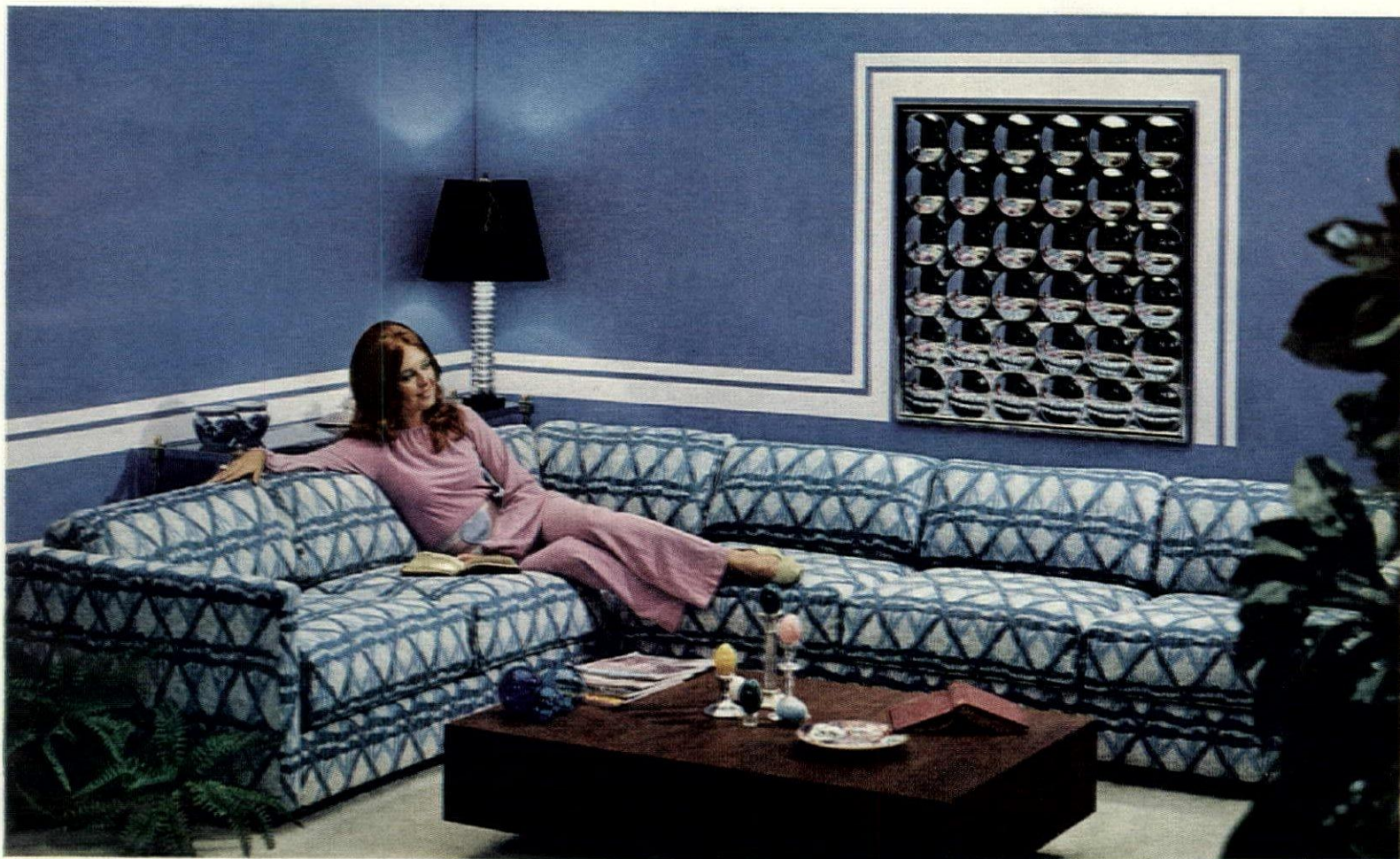

Tru-Test Supreme Sat-N-Hue Flat Interior Latex offers you smooth application with no thinning or lapmarks plus fast, 20-minute drying, amazing durability and easy soap-n-water clean up, all at the price of ordinary paints. Gal. **7.98**

Tru-Test Supreme Marvelustre Semi-Gloss Latex provides incredible resistance to stains, spots and soil in baths, kitchens and other hard-use woodwork areas where super protection is needed. Tough, colorfast finish continues to glisten after repeated scrubbing. Gal. **8.98**



Let's live **COLOR!** Exciting new 24 page booklet, loaded with great new decorating ideas. Available at your nearby True Value or V&S dealer.

Tru-Test Paint is sold only by True Value and V&S dealers who own their own paint factory. Look under "Hardware" in the classified Yellow Pages phone directory.

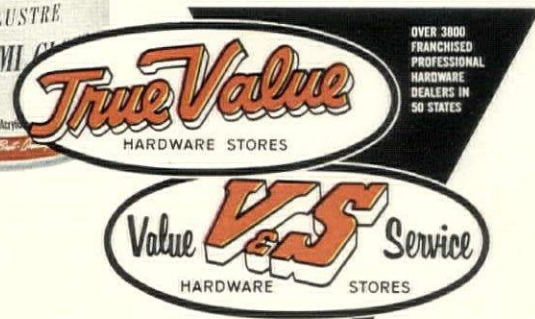

COTTER & COMPANY • 100% DEALER-OWNED • GENERAL OFFICES CHICAGO, ILL. 60614



Heirloom... or reproduction?

Time was such Colonial Chairs could only be found in museums or antique shops, at a price. Now just ask for a Nichols & Stone! In popular finishes, at better furniture and department stores.



The Home of Windsor Chairs



LOOK FOR THIS TAG WHEN YOU BUY
It's your guarantee of the authenticity of design, sturdiness of structure and fine finish that have made Nichols & Stone chairs famous for more than 100 years.
SEND FOR ILLUSTRATED BROCHURE

Nichols & Stone, Box 126, Gardner, Mass. 01441

Enclosed is 25¢ in coin for your 38-page booklet "How to Choose The Right Colonial Chair"

Name _____

Street _____

City _____ Zone _____ State _____

Shopping information

All prices quoted are approximate. *Consult your interior designer or store decorating department.

FOR LIVING NOW

Numbers below correspond to numbers on pages 86-88.

Page 89:

Blocks and wedges (8), 28" x 14" x 14" high, \$35 each for blocks, \$30 each for wedges. Matching chairs (16), 29½" x 28" x 25½" high, \$240 each. Chairs upholstered in white vinyl (26), 30½" x 30" x 27½" high, \$175 each. Cocktail tables (42) with synthetic-slate tops, 42" diam. x 16" high, \$225 each. Buffet tables (7), 60" x 18" x 27" high, \$140 each. All by Founders. Walls covered in natural colored Belgian linen, 54" wide, \$4 yard.* Stereo headphones, \$30 by Magnavox. Zonking Place magnetic ceiling lighting system, 48" polished chrome finish, \$30, with magnetized white enamel Zonker lights (also in red, yellow, or black), \$17.50 each, from George Kovacs. Everything at Bon Marché, Seattle.

"Gropoint" wool carpeting by Bigelow-Sanford, 9' widths, \$15 square yard. Bamboo blinds from Al Burkhardt Custom Shade Co.* Hand silk-screened wooden chest (foreground), 31" x 15½" x 12" high, \$100. Hand silk-screened box (on rear cocktail table), 12" square x 6" high, \$35. Both at Bell Designs.* Sharkskin boxes with ivory trim (on front cocktail table), \$225 each. Cowrie shell boxes with silver bases, \$135 to \$225. All at Chodoff. Dark brown box lined with red felt, 10" square x 3" high, \$120. Dark red porcelain vase, 12" high, \$195. One-of-a-kind plate (on rear cocktail table), 14" diameter, \$120. Orange porcelain vase (on right buffet), 16" high, \$225. All at Paul M. Jones. Red lacquer box, 10" x 8" x 5", \$45 from Tyndale. Baskets (on left buffet), from a collection of one-of-a-kind new and antique baskets at The Gazebo. Spheroid 8-track stereo tape player with AM/FM stereo radio, suction cup base, 12" diam., in white or yellow, \$160 by Weltron. Chrome door handles from William Hunrath.

Page 90:

Love seat (12), 59" x 33" x 27" high, \$483. Matching armchairs (47), 32½" x 33" x 27" high, \$312 each. Dining table (33), 54" diam. x 29" high, extends to 94" with leaves, \$340. Commode, 24" square x 19" high, \$120. Armchair with vinyl seat

(6), 21" x 26" x 43" high, \$90. All by Thayer Coggin at Kaufmann's, Pittsburgh.

Navaho wallhanging, \$110. Navaho rug, \$175. Assiniboine Sioux quilt, \$80. All at American Indian Arts Center. Pillow covers made from bedspreads, \$12 each spread at Sona. Baskets (foreground and on the wall) from The Gazebo. Pottery jars (on commode), \$10 each at The Greenhouse. Basket (left of commode), made in Taiwan, 21" high, \$45 at John Rosselli. "Archimedes Wheel" floor tiles, \$4.75 square foot at Country Floors. Antique natural pine doors, \$80 each at The Village Stripper. Polystyrene ceiling beams, 4" x 6", \$1.85 foot at Butler Lumber.

Page 91:

Poster bed (43), 39" wide x 82" long x 92" high, \$590. Octagonal table (48), 42" diam. x 29" high, \$740. Sofa (23), 96" x 36" x 31½" high, \$1260 C.O.M. Ottoman (2), 30½" x 22½" x 16" high, \$300 C.O.M. Armchair (1) with upholstered seat, 24" x 23½" x 39" high, \$370 C.O.M. Corner cabinet (41), 40" x 84" high, \$1150. All by Baker. Sofa, ottoman, and chair seat upholstered in "Tilla" cotton print fabric, 48" wide, 75" repeat, \$24 yard by Clarence House.* Cube coffee table, 42" square x 15" high, \$150 by Founders. "Beauté" carpeting by Karastan, 12' widths, \$17 square yard. Bed cover of Moygashel Irish linen in Clare quality, 45" wide, \$6 yard. "Paysage" Fortrel/cotton no-iron percale sheets, twin flat or fitted \$6.75, pillowcase \$2.40. 'Creations Primrose Bordier' for Wamsutta. Portable TV with 8" diagonal screen, earphone jack, 10¾" x 9¼" x 10½" high, \$115 by Magnavox. Everything at Hudson's, Detroit.

Antique 3-fold screens covered in 18th-century wallpaper, 94" high, 14½" panels, \$1400 each at Charles R. Gracie & Sons.* Red lacquer Japanese breakfast tray, \$21. Yi Dynasty sake bottle (holding flowers), \$24. Both at Art Asia. Celadon Chinese vase mounted as table lamp, \$350. Antique Persian fruit bowl, 8½" diam. x 4" high, \$45. Both at Rose Cumming. "Italian Fruit" china salad plate (on breakfast tray), \$8.40 at Ginori Fifth Avenue. Japanese Imari platter (on coffee table), \$90 at Art Asia. Antique blue and white plate (in top of cabinet), \$65 at John Rosselli.

Page 92:

Chairs (39), 37" x 39" x 29" high, \$370 each. Matching chaise (17), 77" x 38" x 14½" high, \$595. By Interior Crafts. Red plastic cocktail table, 27" x 17½" x 11½" high, \$45. White plastic serving cart, 27" x 17½" x 24¼" high, \$115. Red plastic stool, 17¾" high, \$32 with cushion (not shown). All by Beylerian. Console table by Tyndale, 19" x 60" x 28" high, \$300. "Straight As An Arrow" wallpaper, \$18 roll by & Vice Versa.* Everything at Lord & Taylor.

Page 93:

Love seat (32), 65½" x 34" x 30½" high, \$687. Matching armchairs (20), 31" x 33" x 30" high, \$378 each. Matching ottoman (15), 30" square x 15½" high, \$177. Single dresser (16), 39" x 20" x 32" high, \$329. Flip-top table (13), 28" x 14" x 26" high, opens to 28" diam. x 25¼" high, \$175. Writing desk (27), 49" x 26" x 30" high, \$395. Bench with upholstered seat (4), 24" x 16" x 17¼" high, \$112. Fourposter bed (18), 80½" high, \$299. All by Henredon. Mattress and box spring by Simmons. Hi-Lo table/server with removable tray, base adjustable to horizontal (shown) or vertical position, 36" wide x 20" deep x 17½" high, converts to 17½" wide x 20" deep x 30½" high, \$230 by Knob Creek of Morganton. Curtains, canopy and bed pillows made from "Cathay" cotton fabric, 48" wide, 12" repeat, \$16.50 yard (20 yard minimum order) by Connaissance.* "Pavillion" rug, 6' x 9', \$699 by Harmony.* Martex Dacron/cotton no-iron percale sheets, full flat or fitted \$6, pillowcases \$4 pair, by WestPoint Pepperell. Mirror with painted wood frame, 26" x 52" high, \$282. Bedside lamp, 30" high, \$86. Both by Tyndale. Blue vase (on desk), \$85. Stationery from the Gloria Vanderbilt Collection by Hallmark. Everything at Jordan Marsh, Boston. Martex white Ultra/VELLUX blanket, full size \$21 by WestPoint Pepperell at R. H. Stearns, Boston. Antique bamboo blanket rack, 20" x 12" x 44" high, \$240 at William L. Designs.* Wicker basket (on dresser), 18" square x 12" high, \$35. Small natural wicker basket (near lamp), 6" x 10" x 5", \$12.50. Antique patchwork quilt (on bed), \$95. All one-of-a-kind from The Gazebo. Antique Chinese porcelain plates (on desk and coffee table), \$60 each at Chodoff.

Page 94:

Orsola chairs imported from Italy (31), 34" x 39" x 26" high, \$310 each. Ottomans (24), 30" diam. x 16" high, \$120 each. Cocktail table (38), 40" diam. x 16" high, \$300. All by Selig. Beautyrest Supreme double mattress and box spring (44), \$200 by Simmons. Sofa table (in hallway), \$110 by Tropi-Cal. Antique carved coconut hull on carved Indian tripod stand, \$225. Bed and pillows covered in cotton

Continued on page 146

look what's
poppin' up
at Ozite.

WOOD HUES



and you can afford it!
all the carpet in this room
costs about \$99.00.

self-adhesive
carpet tile
with built-in
cushion — looks
like hardwood
with an ever
so soft feel.
three shades for
mix and match.

OTHER
NEW IDEAS
FROM



CARPET TILES of all kinds, tufted, shags, needlebonds.



LAWNSCAPE — The synthetic turf that goes anywhere.



BROADLOOM PATTERNS carpeting with decorator styling.



SNIP 'N STICK — The beautiful carpet that self-adheres when you put it down.

Ozite®

CORPORATION Libertyville, Ill. 60048

Hickory Farms.
OF OHIO

ANNIVERSARY CELEBRATION

Begins
Wednesday, Sept. 29



AT 209
HICKORY FARMS STORES COAST TO COAST

MINI-SWISS CHEESE

A superb, sweet, nutlike flavor. Buy it cut fresh from our small five-pound wheels.

REG. \$1.79 LB. ANNIVERSARY PRICE
\$1.59 lb.

SWEET-HOT MUSTARD

Hickory Farms' own distinctive flavor developed from an old German recipe. 6 ounce jar. REG. 55c

ANNIVERSARY PRICE
45c

BEEF STICK®

Summer Sausage

Our world famous Hickory Farms smoked summer sausage. Great eating anytime. Sample before you buy.

REG. \$1.99 LB.
ANNIVERSARY PRICE
\$1.79 lb.



Hickory Farms.
OF OHIO

"AMERICA'S LEADING CHEESE STORES"
209 locally owned
franchised stores coast to coast
Home Office: Toledo, OH 43615

There's a Hickory Farms of Ohio store near you featuring old-fashioned country store atmosphere

ALA Birmingham (3), Huntsville.
ARIZ Phoenix. **CALIF** Bakersfield, Carlsbad, Chico, Concord, Escondido, Fresno, Los Angeles Area: Beverly Hills, Costa Mesa, Downey, Glendale, La Habra, Long Beach, Los Angeles (2), Marina Del Rey, Montclair, Newport Beach, Northridge*, Orange (2), Playa Del Rey, Redondo Beach, San Pedro (2), Torrance, W. Covina*, Whittier; Mountain View, Palm Springs, Sacramento, San Diego, San Francisco Area: Daly City, Hayward, Mill Valley, Oakland, San Anselmo, San Bruno, San Francisco, San Mateo; San Jose (2), Santa Rosa, Stockton, Ventura.
COLO Colorado Springs, Denver.
CONN Enfield*, Hamden, Meriden*, New Haven, New London, Waterbury, West Hartford.
Washington D.C. Area: Alexandria, Arlington,

Annapolis, Gaithersburg, Landover Hills, Rockville.
FLA Ft. Lauderdale, Jacksonville, Pensacola*, S. Miami, West Palm Beach. **GA** Atlanta*, Columbus, Decatur, Savannah. **HAWAII** Honolulu, Kailua. **IDAHO** Boise.
ILL Bloomington. **Chicago Area:** Chicago, Evergreen Park, Harvey, Lombard, Mt. Prospect, Schaumburg*, Skokie, Waukegan (2); Peoria*. **IND** Fort Wayne, Indianapolis (3), Muncie, South Bend (2). **KAN** Wichita (2). **MD** Baltimore, LaVale. **MASS** Braintree, Dedham*, Framingham, Nantucket, Pittsfield, Springfield. **MICH** Grand Rapids*, Kalamazoo*, Lansing*. **MINN** Edina. **MO** Kansas City (3), Kimberling City, St. Louis (2). **MONT** Great Falls. **NEV** Las Vegas. **NJ** Pompton Plains, Westfield. **NY** Albany, Buffalo (3), Long Island (3), Middletown*, New Hartford, Rochester (5), Schenectady, Syracuse (2). **NC** Asheville,

Burlington, Chapel Hill, Charlotte, Fayetteville, Greensboro, Jacksonville, Raleigh (2), Rocky Mount, Wilmington, Winston-Salem. **OHIO** Cincinnati (3), Columbus, Dayton (3), Lima*, Mentor, Springfield*, Toledo (2), Youngstown. **OKLA** Oklahoma City (2), Tulsa. **ORE** Eugene, Portland, Salem. **PA** Monaca, Harrisburg, King of Prussia*, Lancaster*, Plymouth Meeting, Wilkes-Barre*, Wyomissing, York*. **SC** Charleston*, Columbia (2), Florence, Greenville. **TENN** Chattanooga, Memphis*, Nashville*. **TEX** Arlington, Austin*, Corpus Christi, Dallas, Houston. **UTAH** Granger*. **VA** Norfolk, Roanoke. **WASH** Bellingham, Kennewick, Olympia, Seattle (2), Spokane, Tacoma, Wenatchee, Yakima*. **WIS** Fish Creek, Greendale. **CANADA** (7).

*Opening Soon

SHOPPING INFORMATION

continued from page 144

fabric, 47" wide, 30" repeat, \$13.50 yard. By Design Works of Bedford-Stuyvesant for Connaissance.* Colombian pottery from The American Indian Arts Center. Everything at May Company, California.

Wooden cube covered with pieces of horn, 21" square, \$450 at Lutens, Clarey, Stern.* Mirror with hand-made shell frame, 31" x 37" high, \$480 at J. Garvin Mecking. Antique American pine mantel, 71½" long x 55½" high, \$1400. Antique wrought iron andirons with brass finials, 22½" high, \$180 pair. Antique fire tongs, \$30. Antique polished steel shovel, \$50. Log cradles, \$42 set. All at Edwin Jackson. Sisal carpeting, 12" squares, \$1.60 square foot from Continental Importing Co.* Ponderosa pine shutters and doors available through building material suppliers.

Page 95:

Oval extension dining table, 44" x 66" x 29" high, extends to 102" long, \$380. Round extension dining table (30), 44" diam. x 29" high, extends to 80" long, \$310. Side chairs, 20" x 23½" x 40" high, \$107 each. Matching armchairs (5), 20" x 23½" x 40" high, \$127 each. Love seats (9), 57" x 33" x 34" high, \$466 each. All by Ethan Allen. "Red Aves" china dinner plates, \$13.50 each by Royal Crown Derby. "Rattail" silver-plated flatware by Sheffield. Silver peppermills and salt shakers by Windsor. Silver ashtrays by Kirk. Wine liters, \$6 each. Everything at Altman's, New York. "Hearth" ceramic tile floor by American Olean Tile at your local flooring dealer.

Page 96:

Dining table (49), 70" x 44" x 29" high, extends to 110" long, \$375. Side chairs (50), 20¼" x 22¾" x 47½" high, \$95 each. Matching armchairs (19), 22¾" x 23½" x 47½" high, \$110 each. Chests (37), 30" x 10" x 30" high, \$155 each. Love seat (45) upholstered in Scotchgard-protected rayon/cotton fabric, 68" x 34" x 30" high, \$480. All by Drexel. "French Rose" cotton fabric in Sun Yellow (curtains, on chair seats, pillows) and Blue Sky (pillows), 54" wide, 20¾" repeat, \$10 yard by Schumacher.* Everything at Strawbridge & Clothier, Philadelphia. Antique Chinese porcelain ginger jar (on chest), 12" high, \$900 pair. Round wicker basket painted white (right of love seat), \$60. Both at David Barrett. "Fado" pottery dinnerware made in Portugal, dinner plate \$3, luncheon plate \$2.50, salad plate \$2.25, soup bowl \$3.50, coffee pot \$11, creamer \$3, sugar \$3.50, cup and saucer \$4. "Sharon" wine goblets from England, \$7.50 each. "Notsjo" wine decanter from Finland, \$13.50.

Continued on page 148

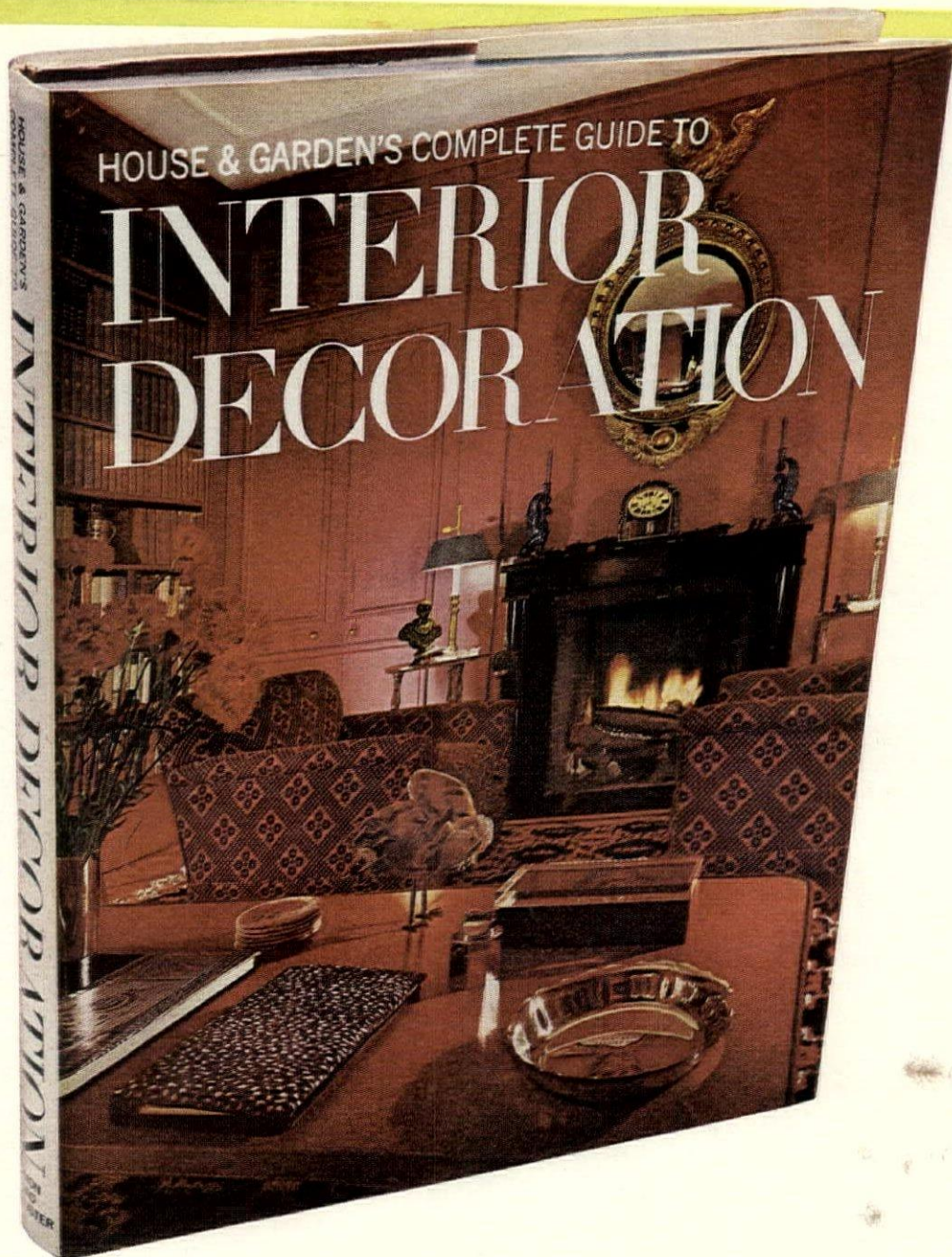

HOUSE & GARDEN'S COMPLETE GUIDE TO INTERIOR DECORATION

TELLS YOU HOW TO

- Decorate in today's idiom ■ Use color effectively
- Select the right carpet and rugs ■ Get the most from limited space ■ Arrange furniture ■ Plan good lighting
- Choose lamps and fixtures ■ Achieve the kitchen you really want ■ Turn a bedroom into a personal haven ■ Have a bathroom that is a delight ■ Use practical ideas for children's rooms ■ Master the art of one-room living ■ Find the storage space you need ■ And more!

ALL NEW! COMPLETELY REVISED!

JUST
\$17.50

Simply enclose your check or money order, and your copy will be shipped promptly—fully postpaid. If you are not completely satisfied with HOUSE & GARDEN'S COMPLETE GUIDE TO INTERIOR DECORATION, return it within 10 days and your money will be refunded.

If you prefer, you may charge your American Express or BankAmericard account.

Condé Nast Books • P.O. Box 3308 • Grand Central Station • New York, New York 10017

HG-1071

I would like to order _____ copies of HOUSE & GARDEN'S COMPLETE GUIDE TO INTERIOR DECORATION, \$17.50

My check or money order for \$_____, payable to Condé Nast Books, is enclosed.

Please charge my account:

American Express.
 BankAmericard Exp. date _____

Acct. # _____

Sig. _____

Name _____

Address _____

City _____ State _____ Zip _____

This is a gift order. Send book and card to:

Name _____

Address _____

City _____ State _____ Zip _____

Card to read: "From _____"



Come home to Barcalounger.



The "Darby," an elegant chair with two rather startling features. It's not only a full-size recliner, but a rocker as well. Gives you more comfort, more ways to relax than any other chair made. Looks smashing in any room. The "Darby" (from \$219) and other models now at great furniture stores everywhere. Let us send "A Chair for all reasons" folder to you with our compliments. Come home to Barcalounger. And relax.

BARCALOUNGER

the original reclining chair
Dept. 10-HG, Rocky Mount, North Carolina 27801

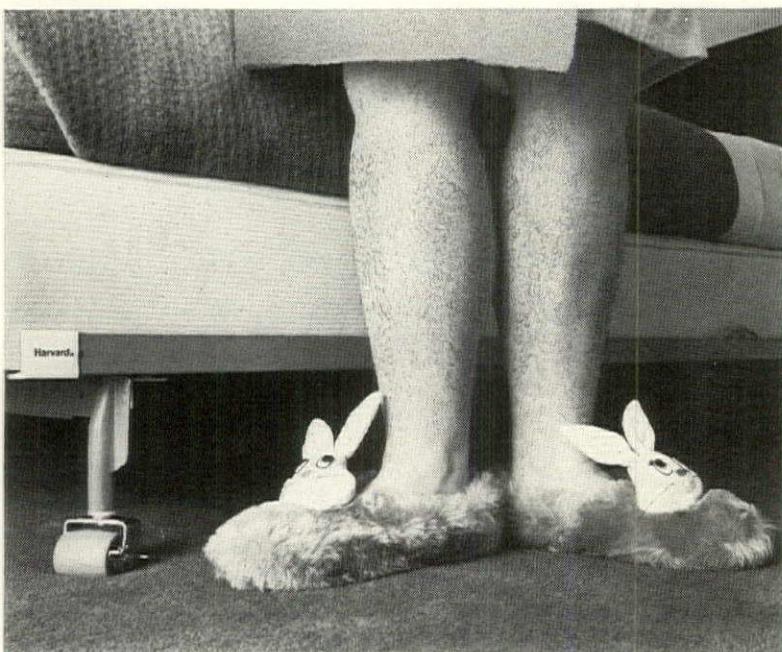

How to spot a bedroom imposter.

Start at the bottom.

Check those beautiful legs . . . super strong with your choice of casters, glides, or gentle-on-carpet Rug Runner wheels. Note the soft end caps with the Harvard name that protect precious bedding.

Imposters may let you down.

So make sure the bed frame you buy has a Harvard label.

Don't settle on anything less.

Harvard[®]

Manufacturing Company
A Division of Rusco Industries, Inc.
Bedford Hts., Ohio; Benicia, Calif.

"Classic" stainless steel flatware by Gentry of England. 4-piece place setting \$13. Baskets from France (holding fruit), \$5 for small, \$6.50 for large. All at Bonniers. Chandelier, 40" diam., \$435. By Dean Trimble at Thurston-McGuire.* Polystyrene ceiling beams, \$1.85 foot at Butler Lumber.

Page 97:

Parsons table (29), 28" x 56" x 29" high, \$115. Étagères (36), 30" x 14" x 72" high, \$145 each. Glass-topped cocktail table (35), 36" square x 16" high, \$135. All by Lane. Love seat (3), 68" x 34½" x 30" high, \$778. Chairs (21), 27" square x 37½" high, \$144 each. Both by Hickory Chair. Brass candlesticks by Virginia Metalcrafters, \$99 pair. White plaster "Tree" lamp with white shade, \$165 (base only) from Isobel Worsley. Stained rattan armchair with cane seat, 23½" x 21¼" x 35" high, \$390 from Yale R. Burge.* Black lacquer table with brass legs, 14" diam. x 28½" high, \$435 from Interior Enterprises.* Versailles linen carpet, 5'4" x 6', \$470 from Stark Carpet.* "Outrigger Rep" white cotton fabric (curtains and on banquettes), 54" wide, \$7.80 yard by Schumacher.* Curtain rod and fittings: Wood pole with natural finish (painted white), 1⅝" diam., from \$2.35 for 4' long to \$7.60 for 12' long; wood finials, \$1.20 pair; wood pole rings, \$1.70 bag of 7; wood pole brackets, 2½" projection, \$2 pair. By Kirsch. Everything at Woodward & Lothrop, Washington, D.C.

Graphics (left to right): "Green Sunbox" by Stamos; "Spartan Sunbox I" by Stamos; "Redcoats Foldout" by Rivers; "Summer Suite C" by Marca-Relli; "Two Bars" by Gottlieb; "Levitation" by Gottlieb; "Africa Suite #4" by Motherwell; "Delphic Sunbox I" by Stamos. All at Marlborough Graphics. Box covered in Fiji Tapa cloth (on Parsons table), 9" x 6" x 7" high. Writing portfolio (custom sizes and covers to order). Shell-covered vase from Bali, 16" high. All from Karl Springer.* Stone mantel, 43" high, \$1200. Andirons, \$125 pair. Both at Danny Alessandro. Brass fire tool set, \$280. Broom, \$6.50. Both at Edwin Jackson. Fireside Plank oak flooring in alternating widths of 2¼" and 3¼", 75¢ square foot or \$6.75 square yard installed. By Bruce Flooring.* (For dealer in your area write Bruce Flooring, P. O. Box 397, Memphis, Tenn., 38101.)

Page 98:

Sofa (28), 84" x 34" x 30" high, \$930. Love seat (22), 66" x 36" x 29" high, \$1052. Chair (34), 30" square x 37" high, \$500. Trestle table (46), 76" x 18" x 29" high, extends to 39" x 76", \$400. Side chair (25), 21" x 19" x 42" high, \$240. African mahogany chest (10) with brass fittings, 36" x 16" x 36" high, \$395. All by Heritage. Floor pillow

covered in fabric by Agnola, 54" wide, \$25 yard from Jack Lenor Larsen.* White table lamp, \$95 by Tyn-dale. Music equipment by Panasonic. Curtain rod and fittings by Kirsch (see above, page 97). Everything at Rich's, Atlanta.

Draperies made from 2 bedspreads, \$12 each spread at Sona. Parchment lacquer coffee table, 40" x 28" x 16" high, \$720. John Michele Frank bench with bleached walnut finish (shown on its side, by love seat), 24" x 16½" x 22" high, \$480. Both at Karl Springer.* Black lacquer box with gold chinoiserie design (on coffee table), 14" x 10½" x 6" high, \$270. Brown pottery fruit bowl, \$30. Both at Ann-Morris. "Chevron" glazed ceramic fireplace tiles imported from Spain, 11" x 5½", \$7.23 square foot at Country Floors. Andirons, \$140 pair. Fireplace grate, \$250. Steel and brass fire tool set, \$125. All at Danny Alessandro. Hand-molded stoneware tile flooring by Structural Stoneware. (For dealer in your area write Structural Stoneware, Inc., Minerva, Ohio, 44657.)

Page 99:

Love seats (40), 60" x 35" x 31" high, \$350 each. Matching armchair (14), 34" x 35" x 31" high, \$206. All by Flexsteel. "Chevron" carpet by Couristan, 12' widths, \$16 square yard. Everything at Joske's, Houston. Plywood environmental forms, 8' high, also available in metal or fiberglass and with doors and shelves for closets. By special order from Joske's, Houston and Garygraphics, New York.

Stainless steel coffee table, 47" x 22" x 21" high, \$4200. Lamp table with mirror finish aluminum base, 34" diam. x 24" high, \$390. Both at John Vesey.* Travertine cube on casters, 30" square x 18" high, \$645. Antique blue and white sea urchin plates (on cube and top stacking table), \$150 pair. Old African tortoise shell on black base, \$435. All at Doris Dessauer. White Perspex stacking tables, 9" to 18", \$390 set of 4. Black Perspex ashtray (on coffee table), 4¾" square, \$15. Matching cigarette box, 4¾" x 3¾" x 3¾" high, \$30. All at Albrizzi. Antique Japanese urn, \$350. Antique Chinese ceramic jar (both in stacking tables), \$420. Antique Japanese ceramic basket (on coffee table), \$440. Antique Japanese bronze bowl, \$140. Antique green ceramic vase, \$200. Blue ceramic vase (all on lamp table), \$320. Antique Korean white porcelain dish (on cube), \$200. All at Charles R. Gracie & Sons.*

COOK BOOK COVER

Page 131:

Italian 1½-qt. Mason jar, \$1.50 at The Pottery Barn. Boda Nova soufflé dishes \$8.75 each at Bloomingdale's. Pyrex 1-qt. soufflé dish, \$5 at Bonniers. Glass table from Longacre Furniture.*

DO-IT-YOURSELF SLIPCOVER

Page 150:

"Flamestitch Tulip" Zepel-protected

Belgian linen/cotton print fabric, 54" wide, 26½" repeat, \$11 yard at Schumacher.* Sofa, 54" long, from Thomas de Angelis.*

**ADDRESSES OF STORES MENTIONED
THROUGHOUT THIS ISSUE**

ALBRIZZI DESIGNS, 979 Third Ave., New York, N. Y., 10022.
 ALTMAN'S, 361 Fifth Ave., New York, N. Y., 10016.
 AMERICAN INDIAN ARTS CENTER, 1051 Third Ave., New York, N. Y., 10021.
 ANDRÉ EMMERICH GALLERY, 41 E. 57th St., New York, N. Y., 10022.
 ANN-MORRIS, 1061 Second Ave., New York, N. Y., 10022.
 ART ASIA, 1088 Madison Ave., New York, N. Y., 10028.
 BETTY PARSONS GALLERY, 24 W. 57th St., New York, N. Y., 10022.
 BLOOMINGDALE'S, Lexington Ave. at 59th St., New York, N. Y., 10022.
 BON MARCHÉ, Fourth & Pine, Seattle, Wash., 98101.
 BONNIERS, 605 Madison Ave., New York, N. Y., 10022.
 BUTLER LUMBER, 2311 Third Ave., New York, N. Y., 10033.
 CHODOFF, 127 E. 57th St., New York, N. Y., 10022.
 COUNTRY FLOORS, 300 E. 61st St., New York, N. Y., 10021.
 DANNY ALESSANDRO, 1156 Second Ave., New York, N. Y., 10021.
 DAVID BARRETT, 24 E. 54th St., New York, N. Y., 10022.
 DORIS DESSAUER, 200 E. 57th St., New York, N. Y., 10022.
 EDWIN JACKSON, 315 E. 62nd St., New York, N. Y., 10021.
 GARYGRAPHICS, 399 E. 72nd St., New York, N. Y., 10021.
 THE GAZEBO, 14 E. 57th St., New York, N. Y., 10022.
 GEORGE KOVACS, 831 Madison Ave., New York, N. Y., 10021.
 GINORI FIFTH AVENUE, 711 Fifth Ave., New York, N. Y., 10022.
 THE GREENHOUSE, 254 E. 51st St., New York, N. Y., 10022.
 HENRI A. KAMER GALERIE, 965 Madison Ave., New York, N. Y., 10021.

HUDSON'S, 1206 Woodward Ave., Detroit, Mich., 48226.
 ISOBEL WORSLEY, 210 E. 58th St., New York, N. Y., 10022.
 J. GARVIN MECKING, 188 E. 64th St., New York, N. Y., 10021.
 JOHN ROSSELLI, 255 E. 72nd St., New York, N. Y., 10021.
 JORDAN MARSH, 450 Washington St., Boston, Mass., 02107.
 JOSKE'S, Post Oak & W. Heimer Rd., P. O. Box 26735, Houston, Tex., 77017.
 KAUFMANN'S, 400 Fifth Ave., Pittsburgh, Pa., 15219.
 LORD & TAYLOR, 424 Fifth Ave., New York, N. Y., 10018.
 MARLBOROUGH GRAPHICS, 41 E. 57th St., New York, N. Y., 10022.
 MAX HUTCHINSON GALLERY, 127 Greene St., New York, N. Y., 10012.
 MAY COMPANY, 801 S. Broadway, Los Angeles, Calif., 90014, and branches.
 PAULA COOPER GALLERY, 96 Prince St., New York, N. Y., 10012.
 PAUL M. JONES, 979 Third Ave., New York, N. Y., 10022.
 POSTER ORIGINALS, 16 E. 78th St., New York, N. Y., 10022.
 THE POTTERY BARN, 231 Tenth Ave., New York, N. Y., 10011.
 R. H. STEARNS, 140 Tremont St., Boston, Mass., 02111.
 RICH'S, Broad & Alabama Sts., P. O. Box 4539, Atlanta, Ga., 30302.
 ROSE CUMMING, 499 Park Ave., New York, N. Y., 10022.
 SONA, 11 E. 55th St., New York, N. Y., 10022.
 STRAWBRIDGE & CLOTHIER, Market & 8th, Philadelphia, Pa., 19105.
 THE VILLAGE STRIPPER, 519 Hudson St., New York, N. Y., 10014.
 WILLIAM HUNRATH, 153 E. 57th St., New York, N. Y., 10022.
 WOODWARD & LOTHROP, 11th & F Sts., Washington, D. C., 20013.

Ekco has the only cookware guaranteed 15 years.* And you get nutritious cooking and tastier meals to enjoy.

Exclusive and striking! Jet black ceramic decorations bonded permanently to stainless steel. Fry, bake, boil up a beautiful feast in Criteria's triply construction... featuring a special sealed-in heat core that cooks faster and more evenly.

Shown, 7-piece set: 1 qt. and 3 qt. covered saucepans, 6 qt. covered saucepot, 10¾" skillet (saucepot cover fits). Price \$44.95. A most-welcomed gift item. Also available in 6 and 10 piece sets. 16 open stock items priced from \$8.95.

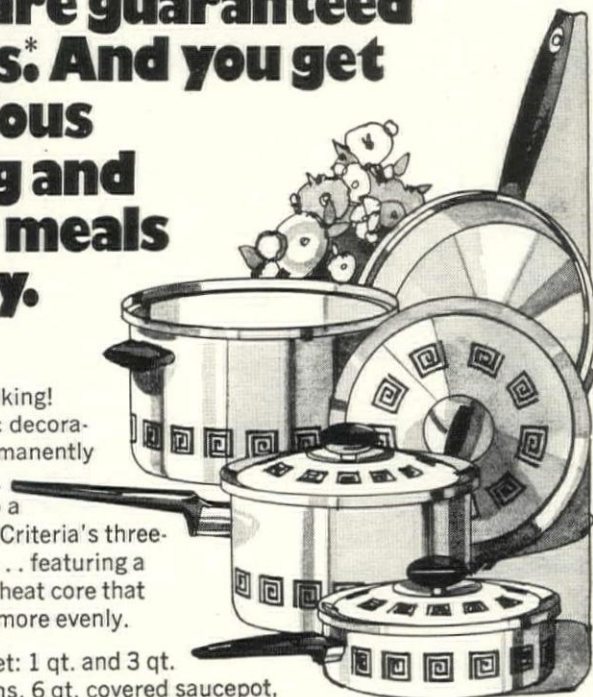

EKCO®

Send for Ekco's free Cookery Book. Write Dept. H1110 Ekco Housewares, Franklin Park, Ill. 60131.

*EKCO GUARANTEE. If Criteria cookware fails due to defects in workmanship or material within 15 years, Ekco will replace or provide equivalent substitute at no charge.

House & Garden SUBSCRIBER'S SERVICE

MOVING?

Please notify HOUSE & GARDEN and the Post Office when you move. For fastest service on address change, missing copies, etc., attach old mailing label in first space below. Otherwise please print clearly your address as we now have it.

OLD ADDRESS

(attach label here if available)

Name _____
 Address _____
 City _____
 State _____ Zip _____

NEW ADDRESS

(don't forget your Zip Code)
Please allow 6 weeks for change to take effect.

Name _____
 Address _____
 City _____
 State _____ Zip _____

NEW SUBSCRIPTIONS or RENEWALS

One year \$7 Two years \$12 Three years \$16

These rates are for U.S.A. & possessions. Canada, add \$1 per year; elsewhere, House & Garden is \$9 per year.

My payment is enclosed Bill me later

HOUSE & GARDEN SUBSCRIBER'S SERVICE

Boulder, Colorado 80302 3001

Building facts

Materials and equipment used in the house next to nature (pages 126-129)

ARCHITECTS: Kroeger-Perfido
CONTRACTOR: Subcontracted by owners

SIZE OF HOUSE: 4,500 square feet
SIZE OF LOT: 20 acres

STRUCTURE

Foundation: Concrete block anchored to existing rock.

Framing: Standard wood frame construction of walls, floors, and roof.

EXTERIOR OF HOUSE

Exterior walls: White stucco over wood sheathing by Tuckstone Stucco Co.

Continued on page 227

HOW TO MAKE A SLIPCOVER LIKE AN EXPERT

Anyone who sews can make a snug slipcover; the trick is in the precise fitting of each piece of fabric on the furniture. The choice of fabric is yours. A tightly woven fabric is the easiest to work with. Most armchairs require 8 yards; a two-cushioned love seat 4½ feet long requires 15 to 16 yards; a three-cushioned sofa, 6¾ feet long, takes 18 to 19 yards of 50-inch fabric. And according to expert Thomas de Angelis, who showed us how to do the job with a linen and cotton print by Schumacher, the current vogue for no-welt-ing simplifies the sewing task enormously.

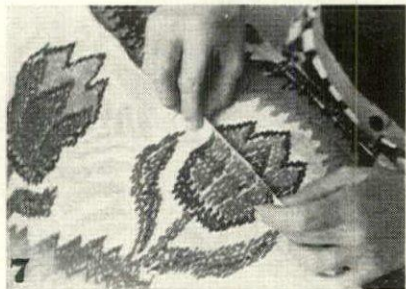

1 Lay fabric on the inside back of the sofa, placing the print to best advantage. Prepare to pin, chalk, and cut the first piece. All the pieces of one half of the slipcover are cut and pinned together before the opposite side is begun.

2 Pin fabric to sofa along top seam of the inside back, using the seam underneath as the guideline, making sure that the pattern is absolutely straight and smooth as you go, leaving only about 2 inches between pins. Stop pinning at top corner.

3 Hold fold of fabric taut with fingers and place another guide pin at corner of arm curve. Pin between guide pins. Tuck the fabric around arm and at bottom, leaving 4 inches. To mark for cutting, chalk straight line 1 inch wide outside pins.

4 Prepare to cut along chalk lines, beginning at the top of the inside back. Before cutting be sure material is smoothly and tautly pinned to the underseams of the sofa. This will help insure an exact fit to the finished slipcover.

5 To cut side of inside back, hold the fold of fabric out with fingers between two corner guide pins and follow chalked line exactly. Next, cut around the curve of the arm, then the bottom tuck-in of the inside back and up the center seam.

6 The inside back piece, after cutting, is ready to be joined to the next piece you cut: the top border. In order to have a continuous pattern of matched fabric pieces, each one has to be carefully fitted to the area cut just before it.

7 To pin the top border to the inside back, you match the pattern exactly as possible, place the cut edges together so that the fabric is smooth, then pin along, following again the underseams. Cut away excess, leaving a ¾-inch seam.

8 To cut the platform of the sofa, which is the part under the cushion, fit fabric to match the continuous flow of pattern to the floor, allowing a 4-inch tuck-in at the bottom of the inside back and the arm. Pin, chalk, and cut as before.

9 The inside sofa arm is fitted just as the other pieces. Notice that the pattern is going at right angles to that on the rest of the sofa. Cut outside sofa arm next, with the pattern going in the same direction as the inside arm piece.

10 Arm-top panel is cut next. Put zipper or snap tape (the kind with tiny snaps) on the outside back running up the right-hand side and on the back of seat cushions, allowing 2 inches of excess fabric for zipper or tape. Before unpinning, notch fabric every 4 inches. Turn slipcover wrong side out, match notches, repin, and sew. *For shopping information, see page 144.*



OLEKSAK



GOOD LOOKS AND GOOD HEALTH

continued from page 48

in *The New Yorker*, where marinated mushrooms at a Thanksgiving dinner felled three people, killing one. Mr. Roueché quotes the doctor in the case "... there was nothing unusual about the mushrooms, I saw them myself. They looked good and they smelled good. Delicious, in fact. It gave me a kind of a chill."

The idea is chilling although the botulism's rarity is what's most impressive to the canning industry where a spokesman has produced figures, immensely impressive to them—775,000,000 cans of commercially prepared food were consumed since 1925 with only three small outbreaks and four deaths from botulism.

This perspective is also shared by the renowned Dr. Meyer mentioned earlier, the authority on botulism who, as he says, has lived with it for more than fifty years, and is the co-author of *Sixty-five Years of Human Botulism in the United States and Canada*. "I've always felt that there should be a standing rule—unbreakable—no home-canned foods ever eaten or even tasted before they have been boiled." He feels that the big commercial canning industries, using their scientists and laboratories, have developed a food technology that is perfectly safe. What about human error which had such tragic results this summer. Dr. Meyer answers "That could never happen in California and 40 percent of the country's stuff is canned here." It was due to Dr. Meyer's efforts that enforcement of the costly and tedious safety methods were passed into law. "If one little squiggle on the record goes below par that whole big batch is taken out and destroyed. What we need is a Nader to make this happen in every state." Ralph Nader, are you listening?

PARTY DRINKS continued from page 138

ready for last-minute blending at party time. For measuring quantities, estimate 3 to 4 glasses of punch per guest. Tea, fruit juices, and ginger ale can be put in waxed cardboard containers and frozen.

Martinis can be made ahead of time and dispensed like punch—perhaps from a huge glass bowl set in an ice-packed bowl. First mix the gin and vermouth in the desired proportions, pour into half-gallon bottles, and chill until icy.

Another good wholesale dispensable is the Bloody Mary. Prepare several jugs of a 4- or 5-to-1 mixture of tomato juice and vodka seasoned with Tabasco, lemon juice, salt, and Worcestershire sauce. Freeze more tomato juice in chunks or cubes, chill the Bloody Mary mixture and serve in a punch bowl with a tomato-ice block or in pitchers with tomato cubes. Keep a bottle of vodka, frozen in a block of ice, at hand for pepping up. For Bull Shots, use frozen beef bouillon in place of the tomato juice and serve in the same manner.

Mass-produced Daiquiris can also be good, provided they are not merely weak rum punches. Use fresh lime juice and sugar syrup or Falernum to sweeten and chill thoroughly. Serve from a bowl or jug packed in ice and pour into chilled glasses or punch cups. Or try an old Tahitian rum drink. A day ahead of the party, insert one vanilla bean in each bottle of light or medium rum and chill. At party time, transfer bottles to ice buckets, pour the cold, delicately vanilla-flavored rum into glasses over crushed ice and add a slice of lime.

Nobody but Ekco has cutlery with a 15-year guarantee.* And it starts at \$1.75.

Cut, carve or slice up fruit for a salad, a meaty roast or a hot loaf of bread. Only Ekco Flint knives give you 7 different edges to choose from... a perfect edge for whatever you're cutting into. Plus mahogany Pakkawood® handles and virtually indestructible vanadium stainless steel to stay sharper longer. Ask for Ekco when you buy cutlery. It's guaranteed!

6-piece set shown: paring knife, utility knife, sandwich knife, French cook's knife, roast slicer and bread knife. Available in Mediterranean or Americana style holdsters. Gift boxed... a most-welcomed gift item. Priced from approximately \$24.95. 27 different knives available.

*EKCO FLINT CUTLERY GUARANTEE: If this product fails due to defects in workmanship or material within 15 years, Ekco will replace or provide equivalent substitute at no charge.



EKCO®

Send for Ekco's free Cookery Book. Write Dept. H1210 Ekco Housewares, Franklin Park, Ill. 60131.

How to select an oriental rug dealer

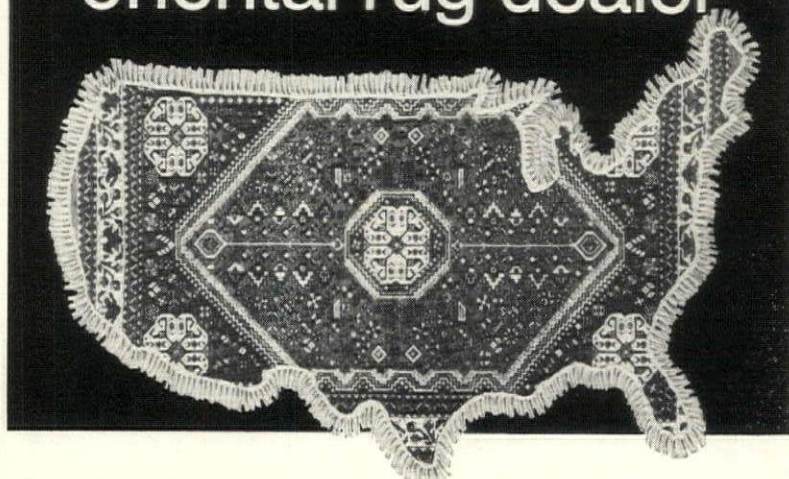

Because Oriental Rugs are one of the lesser known commodities... the proper selection of a fine Oriental Rug is difficult. Since the advent of many Oriental Rug purveyors, finding a reputable dealer can be just as difficult. For reliable and fair merchant representation, always contact your nearest ORRA dealer.

ALBED Rug Co., Wayne, Pennsylvania
AVIGDOR Rug Center, Inc. Brookline, Mass.
DALKRANIAN'S, Miami, Florida
DAVIDIAN, V. & J., Cleveland Ohio
DAVISON'S Oriental Rug Dept., Atlanta, Georgia
DEBEJIAN'S Rug Shop, Utica, New York
MEHDI DILMAGHANI & Co., Inc., Scarsdale, N.Y.
SALEM M. EWAYS, Inc., Charlottesville, Va.
ASTAUR GULAIAN & Son, Kansas City, Miss.
JERREHAN BROTHERS, Philadelphia, Pa.
M. KAMBOURIAN & Son, Inc., Richmond, Virginia

KEBABIAN'S Rugs, New Haven, Connecticut
MR. ZAVEN KISH, c/o Goldsmith's, Memphis, Tenn.
KOKO BOODAKIAN & Sons, Inc., Winchester, Mass.
MARKARIAN, c/o A.B. Closson Co., Cincinnati, Ohio
MEHAGIAN'S Furniture Galleries, Phoenix, Ariz.
K. A. MENENDIAN, Inc., Columbus, Ohio
MUSSALLEM ORIENTAL Rugs, Jacksonville, Fla.
PANDE CAMERON & Co., of Seattle, Seattle, Wash.
PASADENA RUG MART, Pasadena, California
K. A. PRIDJIAN & Co., Chicago, Illinois
V. Y. REJEBIAN & Son c/o Titches, Dallas, Texas
TADROSS & ZAHLOUTE, Detroit, Michigan
WALNUT GREEN GALLERIES, Greenville, Del.
G. S. VARTAN Oriental Rugs, Memphis, Tenn.



ORIENTAL RUG RETAILERS OF AMERICA

P.O. Box 6694, Cleveland, Ohio 44101, (216) 241-3463

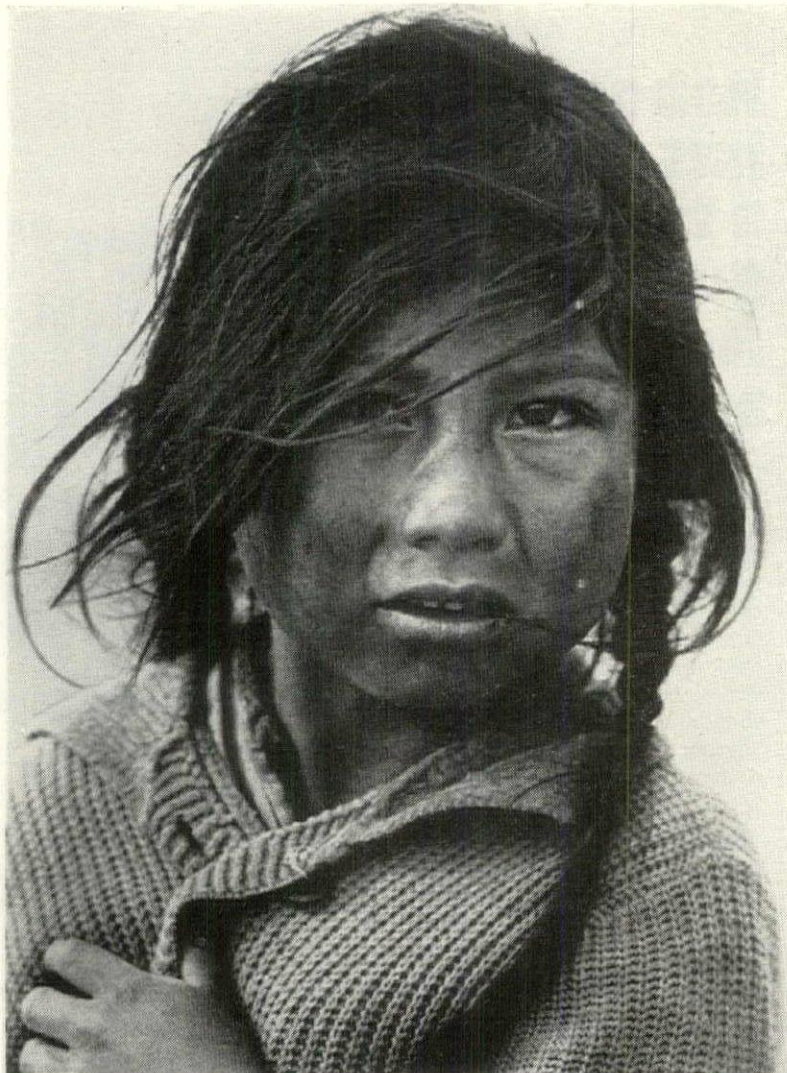

AN ORDINARY DOG IN AMERICA EATS BETTER THAN SHE DOES.

Cristina eats whatever she can find in the garbage. And that is far less than some prowling dog would find in your garbage can.

For just \$12 a month, you can save such a child.

Through our Children, Inc. "Adoption" program you can help provide a child with a better diet, new clothes and medical attention. Even an education.

But there's not a moment to lose. Every 60 seconds, five or six more children will die from starvation.

Write direct to Mrs. Jeanne Clarke Wood, Children, Incorporated, Box 5381, Dept. HG-10, Richmond, Va. 23220.

I wish to "adopt" a boy girl in _____

Name of Country

I will pay \$12 a month (\$144 a year). Enclosed is my gift for a full year the first month. Please send me the child's name, story, address and picture.

I understand that I can correspond with my child, and continue the "adoption" longer than one year if I wish. Also, I may discontinue the "adoption" at any time.

I cannot "adopt" a child, but want to help \$ _____.

Or, I will pledge \$ _____ per month.

Please send me further information.

If for a group, please specify _____

Church, Class, Club, School, Business, etc.

Name _____

Address _____

City _____ State _____ Zip _____

You can "adopt" a child from any of the following countries: Bolivia, Chile, Colombia, Guatemala, Honduras, Hong Kong, India, Iran, Japan, Korea, Lebanon, Mexico, Nigeria, Paraguay, Peru, Syria, Thailand, U.S.A. — Appalochian children or American Indians. (Or a child of greatest need.) All gifts are fully tax deductible.

CHILDREN, INCORPORATED

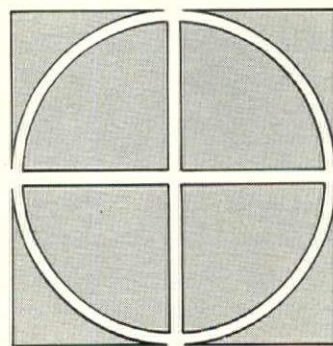

Basic units of eight forms

Ingenious ways to turn one room into two

The simple rectangular room—the kind so many apartment dwellers long to "do something about"—can very easily be made environmentally interesting with the sculptured plywood forms designed by Gary Dobosen (see page 99). Clustered, they create a circle within a square, *above*, 8 feet high, 6 feet wide. Taken apart, they become eight architectural elements almost anyone can lift and arrange in an infinite number of space defining ways. Here are five definitive answers to five problems.

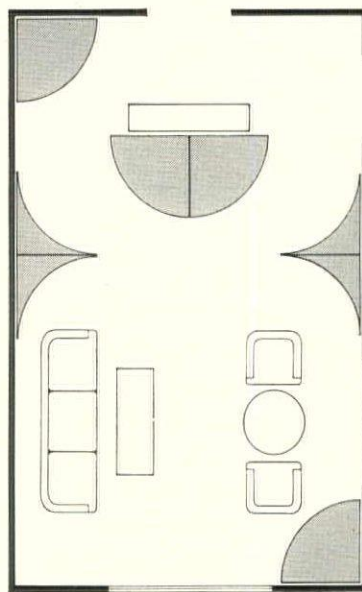

Lacking any sort of entrance area, an apartment can have a pleasant introduction by borrowing enough space from the living room for a foyer. Joined in pairs, the four concave forms suggest a dividing arch; two of the pie shapes form a baffle-like half-column between the two areas; the other two sit in corners as impressively as Nuremberg stoves—one in the foyer, one in the living room.

Bookish people who like all their first editions (and paperbacks) in one spot can have a library simply by cutting their living room in two. In one half, the concave forms—one in each corner—turn the sitting area into a pretty oval; in the other, four banks of bookshelves stretch from floor to ceiling, and the quartet of pie shapes are united in a central shaft as classic as a Greek column.

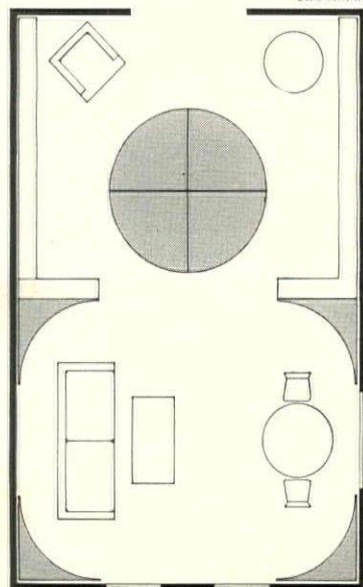

BROTMAN

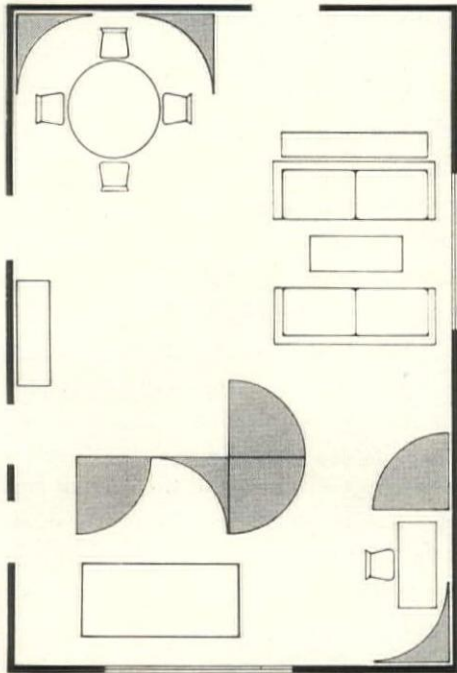

Solution to the problem of making a one-room apartment *not look* like a one-room apartment: In one corner, two of the concave forms are folded around the dining table rather like wings, giving it a nice sense of "apartness" from the sitting area. At the other end of the room, an arrangement of concave and pie shapes not only conceals the bed, but also makes a neat little niche for a desk and its chair.

Another example of slicing off a segment of a living room to create a foyer. In this instance, the entrance area is long and fairly narrow, with two concave forms at one end to turn a sharp right angle into a soft oval. Two of the pie shapes are butted in a half-column baffle, and the rest of the forms are arranged variously as a semi-partition and as enhancers for corners.

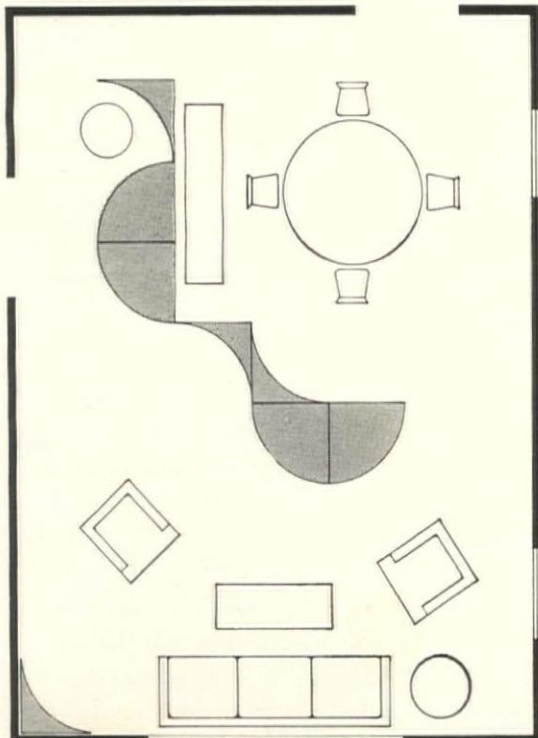
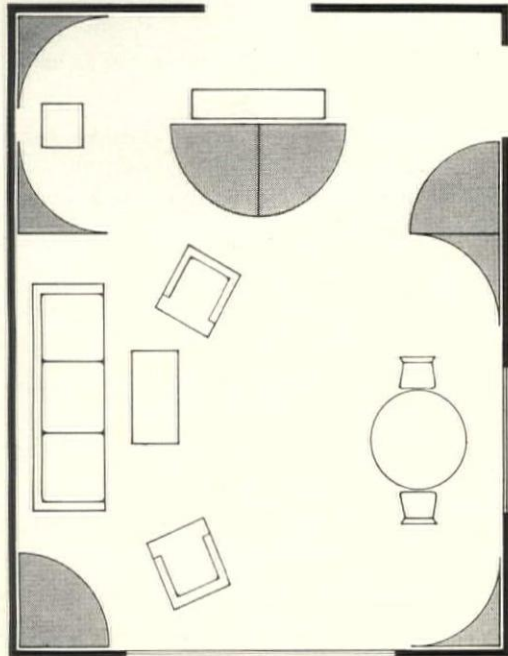

In a sizable room, the forms can be used with great invention to build—quite literally—a wall. Curling across the room in a serpentine twist, the partition almost completely separates the dining and sitting areas, plus offering the bonus of a little entrance area big enough for a table or a chair or (if the owner likes Victorian nostalgia) a nice old hatrack.

Available at Joske's, Houston, and Garygraphics, New York. Complete details on page 144.

Ekco has the only kitchen utensils guaranteed 15 years.* And they're pretty as well as functional.



Ekco Country Garden cooking and serving tools, pretty in the kitchen or dining room. Colorful flowers on dishwasher-safe Melamine® handles. But pretty is as pretty does; these stainless steel tools make flipping, dipping and stirring easier.

7-piece set includes ladle, basting spoon, potato masher, spatula, fork, pancake turner, and wall rack. Gift boxed . . . a most-welcomed gift item. Approximately \$15.95.

*EKCO GUARANTEE. If Country Garden kitchen tools fail due to defects in workmanship or material within 15 years, Ekco will replace or provide equivalent substitute at no charge.

EKCO
Send for Ekco's free Cookery Book. Write Dept. H1410 Ekco Housewares, Franklin Park, Ill. 60131.

In every respect this is the finest reproduction available today. It combines the precision of Chelsea's eight-day, eleven-jewel movement with traditional handcrafted quality. The case is hand rubbed mahogany and has polished brass trim. The glass panels are still authentically hand painted. The door panel is available in a choice of two famous scenes: Mt. Vernon or the Constitution-Guerriere naval battle. Dial: 6". Height: 32". Prices, in a choice of striking and non-striking movements, range from about \$335 to \$395 at finer jewelry and department stores. Or write us today at 289 Everett Avenue, Chelsea, Massachusetts 02150.

Chelsea Clock Co.
A subsidiary of Automation Industries



The Willard Banjo by Chelsea

BARBADOS

ST. JAMES BEACH

Stay at 1; enjoy 3 select resorts on St. James Beach, Colony Club, Discovery Bay, Coconut Creek, Exchange dining, Air cond. Hetland & Stevens, Rep. or your travel agent.

FLORIDA

JENSEN BEACH

FLORIDA HOUSEBOAT RENTALS

Cruise sheltered waterways on an exotic vacation you'll never forget. Boating experience unnecessary. Combine the poetry of secluded aquatic cloisters with a free performance of tropical waterfowl. And the fish always seem to be hungry. Advance reservations now being accepted.

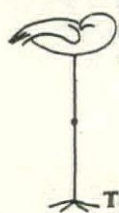

Write for brochure:

Waterbird (H-4)

Box 617

Jensen Beach, Florida, 33457

THE WATERBIRD FLEET

Do you have a "dream of a vacation" in mind ... a place where you can relax, have fun and treat yourself to the finest food? Read House & Garden's Travelog and make that dream come true.

JAMAICA

OCHO RIOS

Plantation Inn. Luxurious club atmosphere. All rooms with balconies facing the sea. See your travel agent or Robert F. Warner, Inc.

NEW JERSEY

ATLANTIC CITY

OCT.
NOV.
DEC.

VACATION . . .

in the sunny autumn, over a long Thanksgiving weekend, for the Christmas holidays. Completely modern with original charm. Adults' and children's game rooms, ocean-front decks, fashionable Edwardian Cocktail Lounge, famous food, renowned Trio, planned entertainment. Write for color brochure and rates.

Marlborough-Blenheim
 5 Magic Acres on the Ocean at Park Place
 Atlantic City 08404
 70 Years White Family Ownership-Management
 Elliot S. Ryan, General Manager

VIRGINIA

IRVINGTON

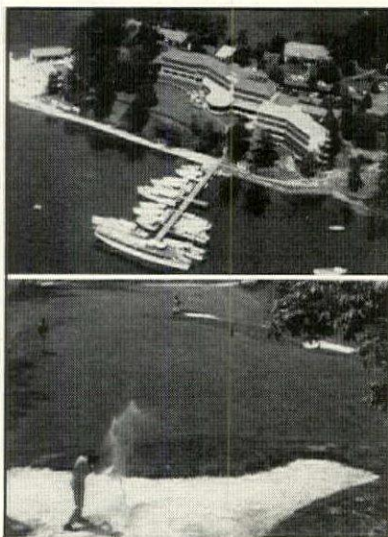

THE TIDES INN & The Tides Golf Lodge

Yachting, golfing, tennis and all the rest in an unsurpassed rural Virginia atmosphere of luxurious informality, within a day's drive of much of the South and East. (212) 586-4500
 Box 109, Irvington, Va. (703) 438-2611

ART FOR EVERYBODY *continued from page 31*

from \$2 to \$3,000. The fact that each multiple—or each print—is not a unique work of art is not of primary importance. Sometimes each impression is unique because of accidental variations in the printing or because the artist has intentionally made slight changes in the stone in the course of printing the edition. On the other hand paintings are often created in series on one theme. What gives a multiple or a print its intrinsic value as art is the degree of involvement of the artist—how closely he supervises the printing or manufacturing and whether he personally passes on the quality of each reproduction. I'm talking, of course, about woodcuts, etchings, engravings, serigraphs, lithographs, etc.—not photographic reproductions of paintings or drawings.

And posters—are they in the same class?

No. Posters are basically for decorative and educational purposes. The original purpose is usually to announce a show. They are perfectly valid for anyone learning about art, but they have no intrinsic value except in the rare case of a limited signed edition of perhaps the first 100 of a printing.

Would you advise beginners to buy sculpture?

Yes, it's easier to live with because it tends to be less fragile. But it might take more space, since you have to look at sculpture in the round. Sculpture now is made in editions by methods such as casting, so prices are apt to be somewhat lower.

How do you feel about renting paintings?

A good idea. Especially for people who are just becoming involved with art. It gives them a wider variety than they might normally be exposed to. Renting a painting gives you a chance to live with it, to understand more about it, and grow to appreciate it. Many museums around the country have special departments that offer rental services.

How about buying art as an investment?

A poor idea. I would venture to say that 90 percent of the so-called investors in art make serious mistakes. There are very few people who really know enough about what they're doing to do it properly. If you're buying a painting, you consider first whether you like it and understand it and really want it. You can buy art to decorate your home. You can buy art to satisfy your aesthetic needs. You can buy art you believe will have lasting value as art. But never as an investment. Really art should only be bought for personal pleasure.

What is the difference between a collector and someone who merely buys art?

If you stop buying art when you run out of wall space, you're not a collector. A collector is continually trying to upgrade his collection. Putting together a collection takes a lot of time and effort—years and years and years of constant trading and rethinking and reevaluating.

But suppose you're not yet a collector—what should you have in order to buy art intelligently?

I think you have to use a certain amount of judgment on your own. You have to have a certain awareness of what's going on in the art world. You should seek the best advice available whether it's from a dealer you trust or a museum curator or a fellow collector. And you should accept this advice, to a limited extent but not blindly—you have to have a certain basic intuition and knowledge yourself.

What do you mean by awareness?

Knowing what the major current trends are. You can keep up on these by following the museum exhibits and the art journals. You may not always agree with them but you should be aware of what's happening.

HELP YOUR POST OFFICE
 TO GIVE YOU
 THE BEST POSSIBLE SERVICE—
 MAIL EARLY IN THE DAY!!

THIS WOMAN REDUCED OVER 10 INCHES FROM HER WAIST, TUMMY, HIPS AND THIGHS IN JUST ONE HOUR

With the Incredible New SAUNA BELT™

HOT PANTS™

THE
ONE DAY
SLENDERIZER
WITH
'INSTANT'
HEAT

GUARANTEED TO REDUCE YOUR WAIST, TUMMY, HIPS AND THIGHS A TOTAL OF FROM 6 TO 10 INCHES IN JUST ONE DAY OR YOUR MONEY REFUNDED

THE ULTIMATE SLENDERIZER FROM BIOPHYSICAL RESEARCH & DEVELOPMENT CORP.—THESE NEW HOT PANTS REDUCERS CARRY THE MOST SENSATIONAL MONEY BACK GUARANTEE IN SLENDERIZING HISTORY.

There has never been an inches-off guarantee like this before. No longer is it necessary to wait months, weeks or even days to lose excess inches from your body... It is now possible to be 6 to 10 inches or more slimmer within just ONE HOUR of taking your Sauna Belt Hot Pants reducers out of their box.

USER'S RESULTS FROM THIS FABULOUS ONE DAY SLENDERIZER

NIKKI McNICHOL: "I went through the Sauna Belt Hot Pants program and just one hour later was 13¼" slimmer! I actually lost 2½" from my waist, 2" from my tummy, 3¼" from my hips and 2½" from each thigh and the inches have stayed off!"

FREDA KLOTT: "Wow! I tried Sauna Belt Hot Pants, the one day slenderizer—and here is what one day did for me—reduced my waist 4¼", took 3½" off my tummy, 2¼" off my hips and 3" off my thighs—a total loss of 13"—Fantastic!"

JOAN TURNIER: "I never dreamed anything could give such incredible results as the Sauna Belt Hot Pants. I used them just one day and lost 14 excess inches! My inch losses were: 3¼" from my tummy—3¼" from my waist—2" from my hips—2½" from each thigh—it's just fabulous—14" trimmer and I didn't even have to diet."

Lovely Pat Karlin, shown here, is an airline stewardess whose job demands a trim figure. When she noticed a few unwanted excess inches, she decided to give the new Hot Pants reducers a try. Pat spent one brief period one day using the amazing Hot Pants program and lost every excess inch, trimming over 10 inches from her figure. Her waist came down from 25½" to 24", her tummy from 34" to 32", her hips from 37¾" to 35", her thighs from 22" to 20"—and her photo shows the truly spectacular figure that she now has.

© Biophysical Research & Development Corp. 1971, P.O. Box 3984, San Francisco, CA 94120 / Patented



AMAZING THERMAL PACKS: The real heart of the Hot Pants program is the special thermal pack unit developed by a scientist from California Polytechnic. These thermal packs are designed to fit under the new inflatable super-insulated Hot Pants reducers, directly over the areas of your body where you most desire to take off excess inches—waist—hips—thighs—or ALL three areas. Incredibly effective, these thermal packs instantly amplify and augment the heat produced by the pants themselves and together with the special brief exercise program, enormously speed up the process of removing unwanted inches. **HERE IS HOW IT WORKS:**



Pat is shown here slipping one of the special thermal pack units under the Hot Pants reducers. Pat used three thermal packs under her reducers—one on each side for the hip and thigh area—one for the waist and tummy area.



After doing the movements of her special Hot Pants program, Pat now relaxes for a few pleasant moments—20 to 30—while the new super-insulated Hot Pants reducers and the amazing thermal packs continue to work their reducing wonders.

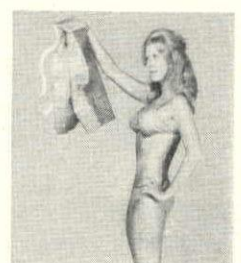

Pat steps out of her Hot Pants reducers. Total time for the entire program: Less than One Hour. Total results for this one brief period: Over 10 inches taken off Pat's waist, tummy, hips and thighs—Hot Pants, the world's most sensational slenderizer.

TRULY PHENOMENAL RESULTS ARE BEING ACHIEVED BY USERS. The new Hot Pants reducers have exploded all existing time barriers in slenderizing. Users are losing a total of 10, 12, and even 14 inches in just one day and are achieving even more spectacular inch losses—if they need or desire them—by continuing the program for 2 or 3 days or more. For maintenance the Hot Pants reducers can be used several times a month or as often as you feel the need. There may be variations of speed and/or degree of results due to individual differences in metabolism and body response. But remember this—these super Sauna Belt Hot Pants reducers are a true wonder and no matter what your metabolism, no matter what your body type, **if you do not lose a total of 6 to 10 inches from your waist, tummy, hips and thighs in just ONE DAY without dieting, you may within 2 weeks return your Hot Pants reducers and the entire purchase price will be refunded.**

HOT PANTS REDUCERS—THE WORLD'S FASTEST MOST EXCITING SLENDERIZING PROGRAM... and the price is only \$14.95... This one price includes everything. You receive your super-insulated Sauna Belt Hot Pants reducers; you receive a supply of the wonder working thermal packs; you receive complete instructions and programs; and most important to you, you receive an unconditional Money Back Guarantee that you must lose a total of 6 to 10 inches from your waist, tummy, hips and thighs in just ONE DAY—without dieting—or your money back.

So if you want to be suddenly slimmer, suddenly trimmer, order your new Hot Pants reducers today and discover what a difference a day makes. Just think, if you had your Hot Pants reducers today you could be 6 to 10 inches or more slimmer tomorrow... or your money back.

SAUNA BELT HOT PANTS, P.O. Box 3984, Dept. HG-17, San Francisco, CA 94120

Please send me _____ Hot Pants reducers along with complete easy to use instructions and program. I understand that if I do not lose a total of from 6 to 10 inches from my waist, tummy, hips and thighs in just ONE DAY I can within 2 weeks return the Hot Pants to Sauna Belt Hot Pants and receive my money back.

For each Hot Pants reducer and complete instructions I enclose \$14.95. (No COD's)

Cash Money Order Hip size _____
 If you desire Air Mail, add \$1.25 for each Hot Pants reducer. Hip size _____

Woman: Waist size _____
 Man: Waist size _____

Name _____ Address _____ City _____ State _____ Zip _____

SHOPPING AROUND

WITH BETTY FAGAN

ORDER MERCHANDISE BY WRITING DIRECTLY TO SHOPS. ENCLOSE CHECK OR MONEY ORDER.

ADD SALES TAX WHERE APPLICABLE.

ANY UNUSED ITEM (NOT PERSONALIZED) MAY BE RETURNED BY INSURED MAIL FOR REFUND.

PLEASE INCLUDE ZIP CODE.

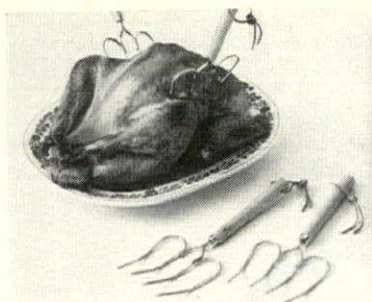

Every kitchen needs these fabulous tools!

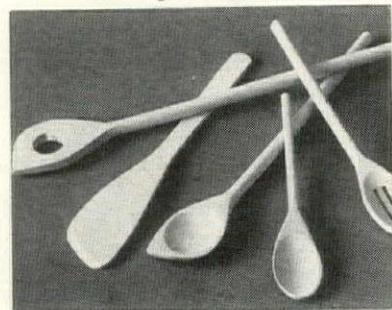

Please add 35c postage

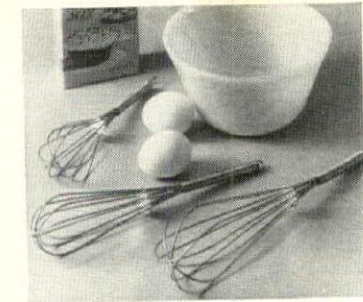

GIANT FORKS (above left) Set of 2 \$1.49

No more perilous juggling acts! Giant forks lift and turn heavy roasts with ease. Heavy steel, specially constructed to grip securely, specially designed to allow juices to drain back. 12" long, cool solid wood handles, leather hanging thongs. #8118

FRENCH WHISKS (above right) Set of 3 \$1.00

Prized by gourmet chefs for centuries—nothing like them for light and airy whipping. You get 3 sizes—8" for fluffy omelets, 10" for velvety sauces, 12" for smooth batters and puddings. Heavy tinned piano-style hoops, hanging loops. #8148

CHEF'S WOODEN TOOLS (at left) Set of 5 \$1.59

Fascinating forms and essential utensils—the finest chefs wouldn't stir without them! Spoons that get into corners, with holes for mixing dough or slots for draining, paddle shaped for folding—each different! Natural wood, 9-14" long. #6077

CGE The Country Gourmet Inc. Dept. G0, 545 Fourth Ave., Mt. Vernon, N.Y. 10550

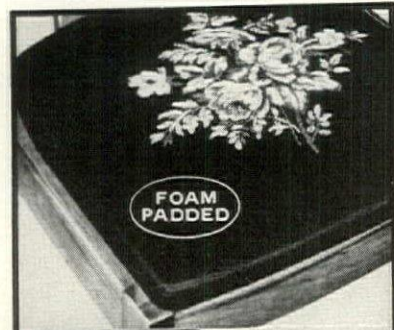

NEEDLEPOINT COVERS add new charm to old chairs! Machine-loomed to wear—look handmade! Black, beige or green frames muted colors of floral pattern. Foam-backed squares; cut to any shape.

20": 52662 Black. 52712 Green. 52522 Beige. Ea., 2.98; 4/10.98
23": 53892 Black. 53942 Green. 54072 Beige. Ea., 3.98; 4/13.98

BRECK'S OF BOSTON SINCE 1818
K41 BRECK BLDG., BOSTON, MASS. 02210



RIDE 'EM COWBOY

The cowboy plaque makes an exciting wall ornament for the study, den, or bachelor's digs. Nicely detailed metal with a gold finish to add western flavor. 13x15".

No. 173—Cowboy Plaque \$2.98
Mailing 35c Each

Calif. residents add 5% sales tax. Satisfaction guaranteed.

Anthony Enterprises Dept. HG101
585 Market St., San Francisco, Calif. 94105



GOOD OLD THINGS®

Nostalgic objects of yesteryear created anew for today's decorative trend. Coal shovels make ideal wall decorations. Coal scuttles perfect as planter, fireplace wood or patio charcoal accessories, magazine holder, etc. Colonial colors offer choice of red, green, black, white (be sure to specify).

SCS-1D Coal Shovel 11" long \$2.95
SCS-2D Coal Shovel Wall Planter with white ceramic pot 11" long \$4.95
SCS-16D Coal Scuttle 11" high \$11.95
Prepaid on receipt of check or money order.

St. Nicholas Boutiques
SANTA CLAUS, INDIANA 47579

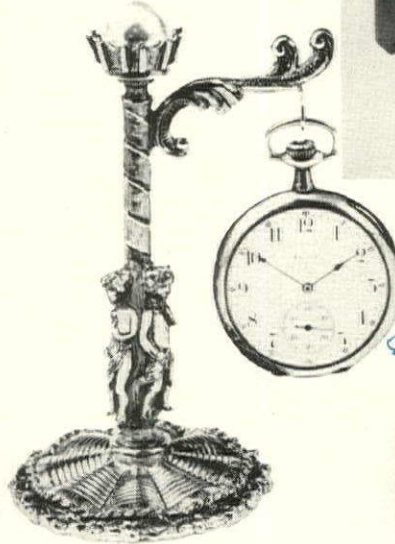

TABLE THIS TRIO

Three to animate any buffet board are hand carvings from Taiwan. Delightful to display and useful, too. Elephant ox hold toothpicks; piglet serves pepper. Ring-necked ox is 4" high; elephant, 4" long and pig, 2 1/4" high. \$3.50 each ppd. Order from Fashions by Donna, HG10, 122 W. 27 St., New York, NY 10001.

WAGON SEAT BENCH

A beauty for blankets, winter woolens, extra bed pillows. Super storage and/or seat is pine and hardwood in honey-tone, maple, antique or walnut finish. Fine at fireside for kindling; terrific for toys and what a happy hope chest! 36" l., 32" h. \$54.95; unfinished kit, \$41.95. Exp. coll. Yield House, HG10, No. Conway, NH 03860.



WATCH IT!

Antique brass mini lamp post is the perfect setting for an heirloom pocket watch. Cherubs circle the base, mock pearl looks like a light at top. Won't tip so your keepsake is safe. 4 1/2" high. \$3.98 ppd. The Ferry House, HG10, Briarcliff Manor, NY 10510.



WISE!

Super smart set of sepia owls on white ceramic plates. Four 8 1/2" plates, perfectly sized for sandwiches, desserts, each with different owl art. Four, \$6.95. The four mugs show all four owls. \$6.95. Add \$1.30 postage the order. Elizabeth McCaffrey, HG10, Northport, NY 11768.

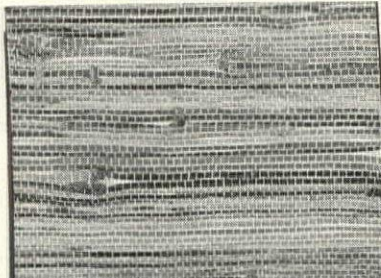

WHOLESALE! DIRECT IMPORT!

GRASS CLOTH

Burlap and many other Textured Wallcoverings

Do-it-yourself and save

Instructions and tools available

Send 50c for set of more than 40 actual samples and prices.

SHIBUI WALLCOVERINGS Dept. HG
P.O. Box 1268, Santa Rosa, Calif. 95403

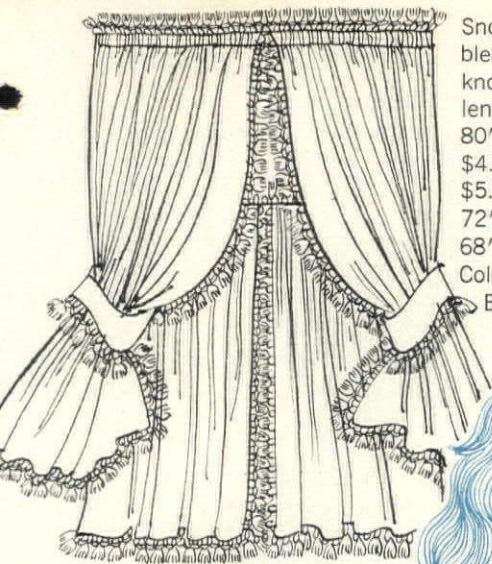

Snow white or natural unbleached muslin curtains with 2" knotted fringe. Hang as tiers, full length or cottage style as shown. 80" wide per pair; 24" long, \$4.50; 30", \$4.75; 36", \$5; 45", \$5.50; 54", \$6.25; 63", \$6.75; 72", \$7.50. Valance, 11" by 68", \$2.50. Add 75c post. Old Colony Curtains, Dept. G101E, Box 787, Westfield, NJ 07090.

PATCHWORK PERFECTION

Country cotton calico in red, black and yellow with broad black bands. Lean, long, lovely. Fully lined; elasticized waist; print sash. S, M, L. \$28. Scoop-neck nylon top is black, white or red. \$11. Add 90c post. Free catalogue. The Talbots, Dept. TE, Hingham, MA 02043.

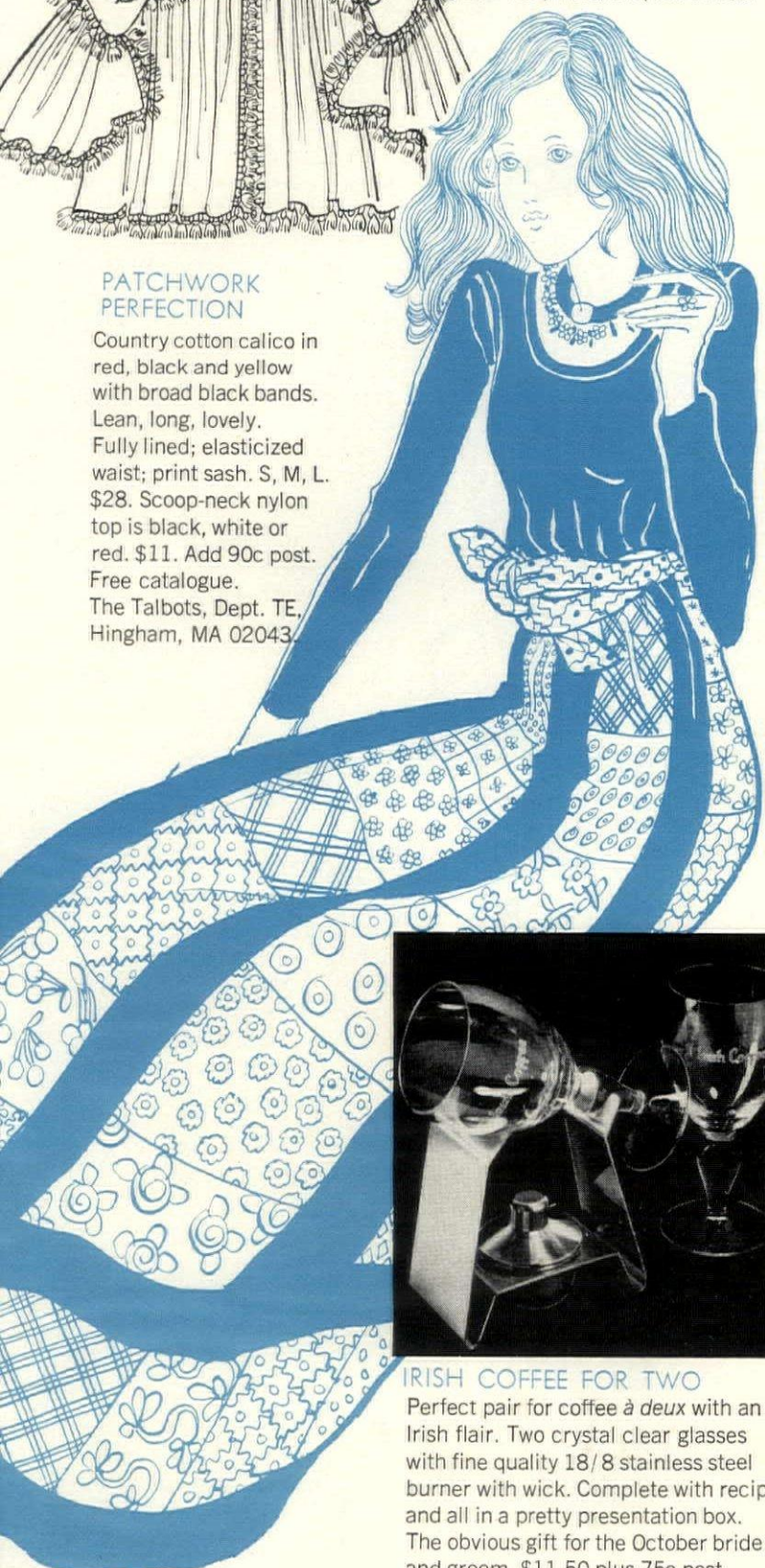

IRISH COFFEE FOR TWO

Perfect pair for coffee à deux with an Irish flair. Two crystal clear glasses with fine quality 18/8 stainless steel burner with wick. Complete with recipe and all in a pretty presentation box. The obvious gift for the October bride and groom. \$11.50 plus 75c post. Camalier & Buckley, HG10, 1141 Connecticut Ave. N.W., Washington, DC 20036.

RAGGEDY GO ROUNDS

Ann and Andy, the ever-favorite redheads rotate to music. Beautifully made of fine white porcelain, they're handpainted in the familiar colors and clothes of the beloved rag dolls. Raggedy Ann plays "Do-Re-Mi"; Andy's tune is "Babes in Toyland". 8 3/4" tall. \$7.98 each ppd. Downs, Dept. 1410, Evanston, IL 60204.



LAVISH AND LOVELY

A most ELEGANT and BEAUTIFUL ENSEMBLE. The delicate design, accented by the puffy fiberfill, presents a lovely floral theme FOR ALL SEASONS. Colors: White, Pink, Green, Gold, Lilac, or Blue on White.

Empress ENSEMBLE

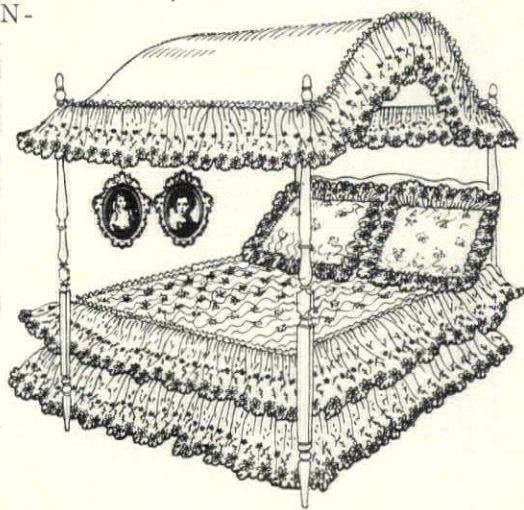

Twin Bedsread—\$59.00
Full—\$65.00
Queen—\$95.00
King—\$116.00
Canopy—\$32.00
Pillow Shams—\$10.00
Vanity Skirt—\$32.00
Valance—\$5.00
Tier Curtains 30" long—\$8.95
36" long—\$9.50

Tie-Back Curtains, Flat Canopies, and any special sizes made to order. Swatches—50c Catalog—75c

Hildegard's GM, 597 Farmington Avenue, Hartford, Conn. 06105



HAPPY DAY RUG!

STOP! LOOK! AND SMILE!

Round rug to keep you smiling! Hang on the wall or throw it on the floor. It's good for a grin every time you look at it. Deluxe quality, nylon all woven including face. 27" round rug with a non-slip Dur-A-Grip backing and it's machine washable and dryable. Use it in the kitchen, den, bedroom or hallway. Canary, Avocado, \$6.95 plus 94c Handling. Satisfaction Guaranteed. SEND FOR FREE GIFT CATALOG.

Henry R. Smith Studios ♦♦
Dept. G101, 39 Crestline Rd., Wayne, Pa. 19087

The Kenton Collection Christmas Book

representing:



KAHN
CARTIER
VALENTINO
MARK CROSS
GEORG JENSEN
GEORGES KAPLAN
KENNETH JAY LANE
1971

Dazzling and imaginative gift-selections from these most noteworthy names in the world of elegance. Now, via The Kenton Collection Christmas Book, a sixty-eight page shopping center, you can browse and buy without ever leaving home. Just send one dollar to: P.O. Box 34257 G Dallas, Texas 75234



FREE
KING-SIZE
SHOPPING
GUIDE

FOR TALL AND BIG MEN

Tired of trudging from store to store looking for Footwear and Apparel that offer fashion and fit? Send for the FREE new 144 Page Full Color KING-SIZE Catalog. Imagine McGregor, Jantzen, Arrow; Shirts, Sweaters, Jackets, Flare Bottoms and Double-Knits. PLUS 200 Shoe and Boot Styles, Sizes 10-16, AAA-EEE. Every item is designed for Tall and Big Men and Fully Guaranteed.

Please rush me your new KING-SIZE Shopping Guide of Apparel and Footwear for Tall and Big Men Exclusively.

Name _____
Address _____

City _____ State _____ Zip _____

The KING-SIZE Co. 4141 KING-SIZE BLDG.
BROCKTON, MASS.

"Anti-Freeze" Jacket

Wind-proof, cold-proof, a topper for town or country, sport or casual wear . . . wherever you require warmth without weight. Made of two layers of Nylon with 5 oz. Dacron Polyester fiberfill insulation between. Car-coat length (36"), has side vents, brass buttons, slash pockets. Good looking, featherlight, and comfortable! Color choice: OYSTER, NAVY, YELLOW. Sizes S, M, L (8-20)



\$22.50 ppd.

Free catalog



Johnny Appleseed's

Box 702, Beverly, Mass. 01915
Zip Code Required!

seamless beauty \$398^{yard.}

ONE-PIECE, FLOOR-TO-CEILING DRAPERIES.
 Now you can grace your home with elegant, 10 ft. wide fabrics woven to hang in deep, royal folds without lining. No seams to sew or show. Pre-shrunk and machine washable. Natural, white or color-matched to your sample. Cover a window or an entire wall and save up to 50%. Your choice of yardage, do-it-yourself materials—or completed, tailor-made draperies. Money back guarantee. Send 50c (\$1 air mail) for brochure and portfolio of swatches. "Refunded with order."



HOMESPUN HOUSE,
 9038 Lindblade, Culver City, Ca. 90230.



ELEGANCE YOU CAN AFFORD

Send 35c for 68 PAGE ILLUSTRATED CATALOGUE. Chandeliers, sconces and candelabra of imported crystal. Incomparable in design and quality. Pewter and early American brass. \$50.00 to \$1250.00. Shipped prepaid, insured in U.S.A. Satisfaction Guaranteed. In business for over a quarter of a century.

KING'S CHANDELIER COMPANY
 Dept. G-65, Eden (Leaksville)
 North Carolina 27288

PRELUDE — \$21.00
 plus \$1 ppd.
 In Black calf with a strap-happy T and 1" heel, beloved of the "talls."

Money Back Guarantee

NO EXTRA CHARGE FOR LARGER SIZES

all 'n Slim®

WIDTHS 6A's to B
 SIZES 6 to 13
 "FITTING THE NARROW HEEL"

WIDTHS	SIZES
6A's	7½ to 13
5A's, 4A's	6 to 13
3A's, 2A's	9½ to 13
A, B	9½ to 13

ORDER BY MAIL

SEND FOR FREE CATALOG HG-10

mooney & gilbert inc.

31 West 57th St., New York, N.Y. 10019
 5th Floor — Sohmer Building



TIBETAN UMBRELLA PINE

For bonsai—Yearling in 2" pot, with our fertilizer, training wire, soil condit. \$1.95 & instructions. (Mature specimen shown)

CHRISTMAS BONSAI KIT

One Japanese Black Pine, One Calif. Redwood, 2 imported bonsai pots, appr. 24 sq. in. & 18 sq. in., planter mix, Westarbor fert., iron soil cond., training wire and instructions, special complete. \$6.99 ppd.

Western Arboretum now offers over 400 unusual live trees suitable for bonsai. Not over 11" tall shipped wet-pack in 2" pots. Assorted Special this month includes: Italian Stone Pine, Chinese Blue Juniper, Monterey Pine, Austrian Pine, Japanese Black Pine, all 5 for \$5.99 (\$1.35 ea) ppd. Calif. Redwood, \$1.69 ppd. Catalog of trees, imported pots, tools, supplies, 25c, free with any order. Satisfaction guaranteed.

WESTERN ARBORETUM, Dept. QQ
 435 No. Lake, Pasadena, Calif. 91101

Unusual Gift



NEW!
 Compile your own Family Genealogy, CHARTS TELL HOW

100 Pedigree Charts
 Sheets only for standard binder.

FAMILY HISTORY RECORD

With these pedigree charts and the easy-to-understand instructions, the amateur or professional can trace and compile a family history to be treasured throughout the years to come. Punched for 3 ring binder, this 100 page set contains 6-generation ancestral charts, pedigree forms, biographical data sheets, family history forms, plus space for notes and photographs.

Immediate shipment via 3rd Class Mail @ \$3.95 ppd. or via Air Mail @ \$4.75 ppd. Send check or money order. Ten day refund if not completely satisfied.

An Ideal Gift for Friends or Family
 Order From

CHESCO COMPANY

Dept. HG10

P.O. Box 533, 346 Maple Ave., Westbury, N.Y. 11590

SHOPPING AROUND



WORK HORSE

Now, a butcher block work table with the convenient plus—a spacious drawer for cutlery, utensils. 2" block top, 34" high, 36" by 24", \$119.50; 48" by 24", \$129.50; 48" by 30" and 60" by 24", \$139.50; 60" by 30", \$159.50. Also, 30" high. Exp. collect. Catalogue, 50c. J & D Brauner, Inc., HG10, 298 Bowery, NY 10012.



IMAGE MAKER

Right and round for a hallway niche or a sunny guest room is this pretty little mirror. The wooden frame hand-painted in traditional Norwegian design. 11¼" dia. White, black, red or blue background. \$5.95 plus \$1 post. Brochure showing imported sweaters, figures, wall decor, 25c. La Boutique Unique, HG10, Box 823, Stamford, CT 06904.



AMERICAN EMPIRE SET

Made for the little girl who loves doll houses (and bigger girls who collect miniatures) is a set of four handmade cherry chairs with seats upholstered in plaid with a pedestal table with three legs. Empire goes with any period doll furniture. \$6 ppd. Furniture and toy catalogue, 25c. Federal Smallwares Corp., HG10, 366 5th Ave., NY 10001.

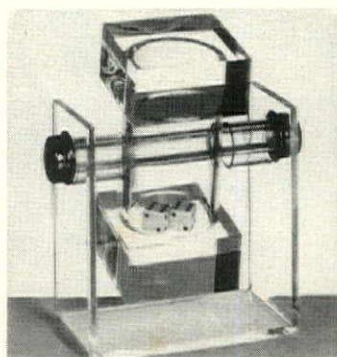

SPIN FOR DRINKS

Great addition for the office desk or home bar is an adult spinning dice game completely encased in transparent acrylic. Splendid pastime for an afternoon's play between halves of a football game. Game does double duty as a paperweight. \$10 ppd. Edith Haas, HG-E, 130 W. 42 St., New York, NY 10036.

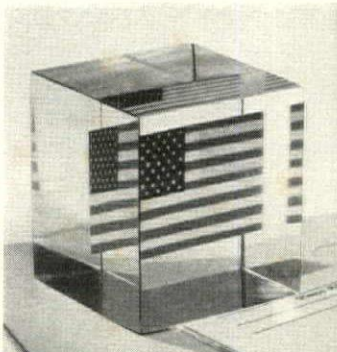

OLD GLORY

In honor of all things American—a flag paperweight. Stars and stripes can be yours forever with this 2" cube. Old Glory seems to float in clear lucite. \$1.98 plus 20c post. Great for home, school, office, or makes a good bridge prize. Order from Anthony Enterprises, HG10, 585 Market St., San Francisco, CA 94105.



NATURAL ART

Charming is the word for original wildlife lithographs by artist Michel. You have a choice of endearing raccoons, baby beaver, rabbit or chickadee—all caught in delightful posters, all signed by the artist. 11" by 14". \$3.50 each or set of four, \$10 ppd. Available only from The Frame Shop, HG10, 7120 W. Touhy Ave., Niles, IL 60648.



GOBLETS

Handcrafted of Armetale, these Goblets become incredibly cold when chilled and stay cold for long periods of time. Armetale Goblets won't dent, leak or tarnish. Wine Goblet, 5" high, 5 oz. cap.; \$7.50 ppd. Water Goblet, 7" high, 11 oz. cap.; \$8.50 ppd. Over 300 Armetale items in our new 78 page color cat. Yours for only 50¢! Money refunded if not delighted.

sagittarius enterprises
315 Tenbytowne Delran, N.J. 08075

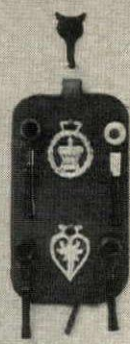

PIPE RACK

Made by Amish craftsmen in Pennsylvania, this Pipe Rack is hand tooled of harness leather in a walnut finish, with hand polished solid brass amulets. Fox head hook included. Shown above is our 12" x 7" Rack. \$15.00 ppd. (pipes not included) Also available, 8-pipe Rack, 24" x 7", \$25.00 ppd. Many early American items in our 78 page color cat. Available to you for 50¢! Money refunded if not delighted.

sagittarius enterprises
315 Tenbytowne Delran, N.J. 08075



WINE CART

A very unusual wine rack on wheels. Holds 20 bottles, and has a formica shelf for resting hors d'oeuvres, opening wine bottles or mixing drinks. In sturdy black wrought iron. Wheel it from room to room during festive occasions! 35" high, 15" deep, 17" wide. Weighs 50 lbs. \$65.00 shipped express collect. See our other exciting wine racks in dec. colors in our 78 page catalog, only 50¢! Money refunded if not delighted.

sagittarius enterprises
315 Tenbytowne Delran, N.J. 08075



HORN MUG

This great-shaped mug is made of Armetale—the metal that retains cold long after others have gone flat. For sporting bloods, a 10 oz. capacity. May also be used as an unusual planter. Armetale won't rust or tarnish, and is dishwasher safe. 5" high; \$7.50 ppd. We have over 25 different Armetale mugs in our new 78 page color catalog. Send 50¢ for your copy today! Money refunded if not delighted.

sagittarius enterprises
315 Tenbytowne Delran, N.J. 08075



LOG CARRIER

Excellent idea for carrying logs in from the wood pile on a cold winter eve! Made of sturdy leatherette, maroon in color, with tough fabric liner. Shown above with covered bridge silk-screened in gold. Also in Eagle or Hearth design. 13" wide. Please specify design. \$6.75 ppd. Great gifts from New England in our 78 page cat. Send 50¢ for it today! Money refunded if not delighted.

sagittarius enterprises
315 Tenbytowne Delran, N.J. 08075

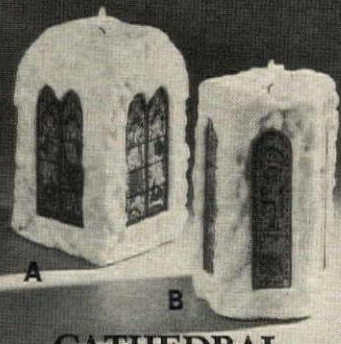

CATHEDRAL CANDLES

Made in Ireland of pure white wax, and decorated with full color windows that are authentic copies of famous European Cathedrals. Windows glow like stained glass as the 75-hour wick burns. 4" x 6"; \$5.75 ppd. Please specify (A) Cologne, or (B) Notre Dame. Votive refills available as well as an incredible variety of candles in our 78 page color catalog. Send 50¢ for it today! Money refunded if not delighted.

sagittarius enterprises
315 Tenbytowne Delran, N.J. 08075



DECANTER

Imported Old World Wine Decanter is handblown from heavy lead crystal. Slug of lead indicating purity of the crystal is implanted in the medallion. A most beautiful addition to your wine service. One Liter cap. (approx. 1 qt.) 11" high; \$8.00 ppd. Also available in 1/2 Liter cap.; \$6.00 ppd. Our 78 page color catalog has many unusual values in imported crystal. Money refunded if not delighted.

sagittarius enterprises
315 Tenbytowne Delran, N.J. 08075



SAUSAGE HOOK

Imported from Southern France, and created by artisans dedicated to authentic reproductions of the 15th to 17th centuries. Made of sturdy black hammered iron, with chain—without which no gourmet kitchen is complete. Diam., 10"; Height, 23" incl. chain. Weight, 5 lbs.; \$26.00 ppd. Our new 78 page color catalog is full of gourmet accessories. Send 50¢ for it today! Money refunded if not delighted.

sagittarius enterprises
315 Tenbytowne Delran, N.J. 08075



DOORKNOCKER

Sweetheart doorknocker is made of sturdy hand-cast iron, in antique gold finish. Young lovers heads come together in a kiss when the knocker is used. Giftboxed, and complete with two mounting screws. 5" x 3". Great gift for young marrieds! \$4.25 ppd. We have a full variety of unusual gifts in fine taste. Send 50¢ for our 78 page color catalog today! Money refunded if not delighted.

sagittarius enterprises
315 Tenbytowne Delran, N.J. 08075



TAPESTRY

Imported from Europe. This quilted Tapestry depicts Emperor "Charles the Courageous" of Burgundy. Colors are pale blue, red and green on a field of white. Outer borders are gold brocade. Hand printed on woven linen and cotton, 35" x 30". Comes with 37" wooden rod and 2 finials. \$48.00 ppd. Many other Tapestries in color in our 78 page catalog, available to you for 50¢. Money refunded if not delighted.

sagittarius enterprises
315 Tenbytowne Delran, N.J. 08075



COPPER PLANTER

Imported from Holland, this handmade beauty is an authentic copy of an antique coal helmet—shaped according to the most ancient traditions. All-Copper with two delft handles and bake lacquered for tarnish resistance. A great planter or dec. piece. 12" high; \$35.00 ppd. Smaller version has one delft handle, is 7" high and comes tin lined. Can be used for snacks or candy; \$14.00 ppd. Send 50¢ for our catalog and see our other pieces! Money refunded if not delighted.

sagittarius enterprises
315 Tenbytowne Delran, N.J. 08075

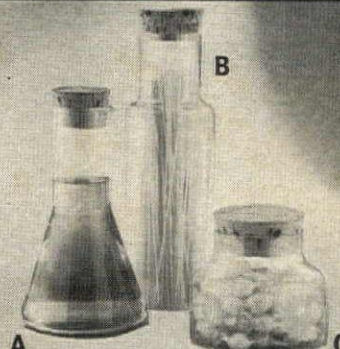

KITCHEN CHEMISTRY

The exciting new "natural" look of Crystal and Cork! Clean simple designs, permit the beauty of food to show "show-through." All handblown. Shown above: (A) Flask, 26 oz. cap.; \$7.75 ppd. (B) Spaghetti Jar, 13" high; \$7.75 ppd. (C) Canister Jar, 5" high; \$6.50 ppd. Many more sizes and exciting shapes of Kitchen Chemistry in our new 78 page color catalog. Send 50¢ for it today! Money refunded if not delighted.

sagittarius enterprises
315 Tenbytowne Delran, N.J. 08075

From Fabulous San Francisco, ANTHONY ENTERPRISES unveils
47 Exciting new ideas for gifts and better living



Special Award for the Golfer Who Hits a Long Ball.



Golfer's Diet Plaque. Wood Frame, 5 1/4 x 6 1/2".

GOLFER'S GAGS

- No. 146—Long Ball Hitter Award
- No. 132—Golfer's Diet Plaque
- No. 157—Definition of Golf Plaque
- No. 170—Nude Golf Tees

\$1.98 Each + 30c Mailing Each



Definition of Golf Plaque. Wood Frame, 5 1/4 x 6 1/2".

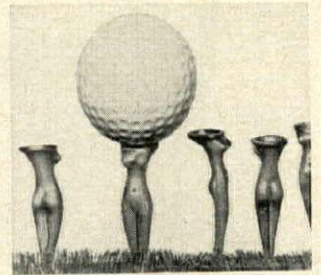

12 Multi-Colored, Plastic, Nude Golf Tees.

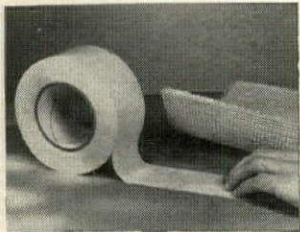

CARPET TAPE

Carpet tape prevents skids and falls. Tackless carpet installer "floors" scatter rugs, runners, room size carpets. 1 1/2 inch by 12 foot roll is double-faced to stick to both surfaces. Removable and re-usable.

No. 169—Carpet Tape \$1.49
Mailing 15c Each



STEAM IRON COVER

At last you can iron all hard-surfaced fabrics without causing shine. Simply slip one of these covers over your steam iron. Puts new beauty in serges, gabardine, dull-surfaced silks, woolens and knits.

No. 189A—Iron Cover \$1.00
Mailing 15c



TUB TAPE

Self-adhesive white tape seals the cracks and openings around the bathtub, sink, or basin. Press self-adhesive tape onto clean, dry surface and it's ready to work. Water-proof, easy to clean. 11 foot roll.

No. 201—Tub Tape \$1.98
Mailing 30c Each



WRITE SHORTHAND IN 4 DAYS!

Clerk-typists—make more money right away! Invaluable for students. Uses alphabet, no strange symbols. No tedious learning period. Complete 4-lesson course, with a practice handbook to develop speed.

No. 165—Shorthand Book \$2.98
Mailing 15c Each



FAT FREE BROILER

Heavy cast iron pan broils on top of stove, steaks, fish, or chicken without grease. Heat pan and place meat on ribbed bottom. Drippings drain away—flavor is sealed in. Measures 11 inches across top.

No. 190—Broiler \$10.98
Mailing \$1.85 Each

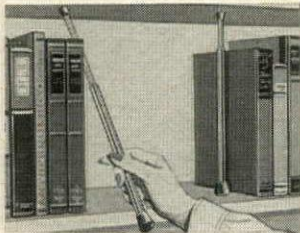

SPRING POST BOOKENDS

Post Bookends keep library books orderly, upright. Install in seconds, adjust to fit 9 1/2 to 13 1/2" high book shelves. Keep your built-in looking organized. Gold-finished anodized aluminum. Set of 2 posts.

No. 203—Post Bookends \$1.49
Mailing 20c Each Set



CLEANS SILVER FAST

Magic Leaf goes in the dishwasher, cleans your silver as you wash the dishes. Keeps silver shining bright and tarnish-free. It cleans engraved and embossed surfaces, even gold and silver jewelry. Odorless.

No. 205—Silver Leaf \$1.19
Mailing 15c Each



PAGE MAGNIFIER

Page Magnifier is easy on the eyes. Hold 7x10" magnifier 4 or 5 inches from copy for more comfortable reading. The whole page is magnified at one time! Stop squinting at telephone numbers, dictionaries.

No. 204—Page Magnifier \$1.98
Mailing 15c



84 CARD TRICKS

An explanation of the general principles of sleight of hand. And to become an expert in this hocus-focus requires very little practice. There are enough tricks to while away hours of time in real pleasure.

No. 171—Card Trick Book \$1.00
Mailing 15c each

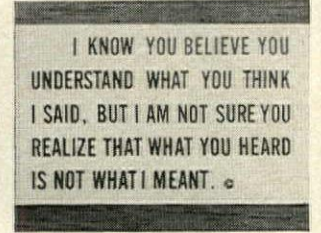

COMMUNICATION GAP

How's that again? A wall plaque which will rivet every eye's attention. Makes a perfect gift and is guaranteed to bridge the communication gap. Black letters on a golden plate in pine-finish plaque. 4" x 5".

No. 185—Communication Plaque \$1.98
Mailing 20c Each

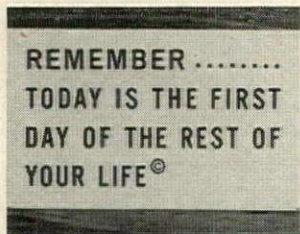

REMEMBER
TODAY IS THE FIRST
DAY OF THE REST OF
YOUR LIFE®

A NEW DAY

Never too late to change the course of your life! Inspirational wall plaque says, "Remember . . . Today is the first day of the rest of your life." Black letters on golden plate in pine-finish plaque. 4" x 5".

No. 180—First Day Plaque \$1.98
Mailing 20c Each

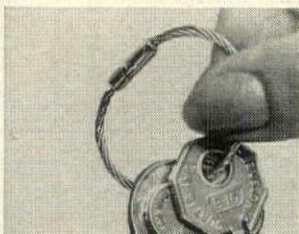

UNIQUE TWISTY KEY RING

No more lost keys. No links to loosen . . . no chains to break. Intriguing twist-lock opens easily—stays closed. Holds 25 keys. Withstands the pull of 150 lbs. Made of aircraft cable in smart gold finish.

No. 179—Twisty Key Ring \$1.29
Mailing 15c Each

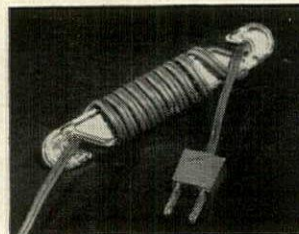

CORD SHORTENERS

Cord Shortener keeps those dangling electrical cords off the floor and out of the way. It holds up to three feet of cord. Just wind excess cord around the shortener and hook the cord in slots at end. Set of 6.

No. 195—Cord Shorteners \$1.29
Mailing 15c Each Set



EYEGLASS NOSE PADS

Here's the answer to glasses that slide down your nose! Tiny flesh-colored foam rubber pads that stick to any eyeglass frame. Relieves the pressure of heavy frames on sensitive spots. Set of 12 pads.

No. 127—Eyeglass Pads \$1.00
Mailing 15c



WORK WHILE YOU TALK!

"Shoulder Rest" holds the phone for you—leaves your hands free. Comfortably padded. Ends tired arms, sore neck. Fits all phones. Attaches in seconds for either right or left side. Black, beige, white, grey, green or red.

No. 130—Telephone Holder \$1.98
Mailing 25c Each

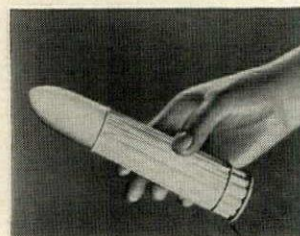

CORLESS MASSAGER

Battery-operated massager brings satisfying relaxation. Deep, gentle penetrating massage gives soothing relief from aches and pains and stimulates circulation. Batteries not included. Two sizes.

No. 196A—Massager, 7" \$3.98
No. 177—Massager, 10" \$6.98
Mailing 45c Each

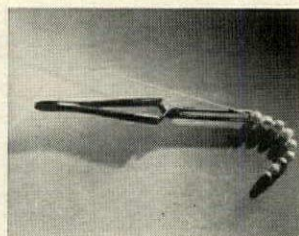

IT'S EASY TO RE-STRING BEADS!

It's easy, that is—if you have this clever bead stringer. It does the job quickly. Ties knots close between beads and next to clasp. Prevents scattering in case of breakage. Extra strong strands included. Complete with instructions.

No. 147—Bead Stringer \$1.29
Mailing 15c Each

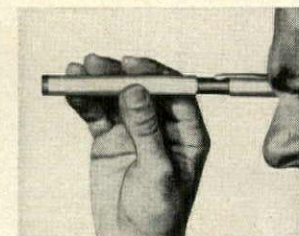

PEN SIZE TELESCOPE

Observe objects and people blocks away with the Spy Scope that fits pocket or purse. Has 8-power magnification, adjusts quickly for long-range viewing. Converts to 30 power microscope for precision work. Lightweight pocket clip.

No. 149—Spy Scope \$1.98
Mailing 15c Each



VEGETABLE STEAMER

Now always serve nutritiously delicious tender-crisp perfect vegetables with aluminum french folding steam basket that makes a double boiler. 6" wide with sides up, 9" flat. Wire handles for lifting. Will not tarnish.

No. 187—Steam Basket \$3.98
Mailing 40c Each

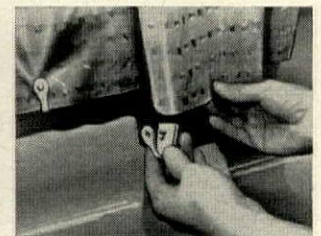

ELIMINATE WET FLOORS

No more shower curtain blowing. Plastic snap-on Magnetic Shower Curtain Holders hold shower curtain tight to tub or metal stall. Permanently magnetized. Will not rust or mar any surface. Set of 3.

No. 188—Curtain Holders \$1.29
Mailing 15c Each Set

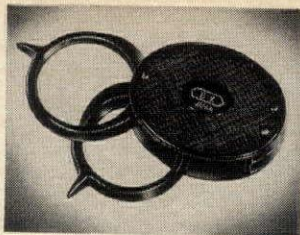

DOUBLE POCKET MAGNIFIER

Handy in dozens of ways! Use one lens, or two—for 4 power or 8 power magnification. Wonderful for reading small type, removing splinters, checking stamps or coins, hobbies. Lenses fold into sturdy, protective case when not in use.

No. 167—Pocket Magnifier \$1.98
Mailing 15c Each



MAGIC MENDING

New miracle crystal clear liquid glass chemical sensation creates a washable, waterproof, heat-or-cold proof iron bond. For permanent mending or repair of glass, china, crockery, ceramics and porcelain.

No. 178—Liquid Glass \$1.98
Mailing 15c Each



15-SECOND RUST REMOVER!

Rust, stains, tarnish disappear like magic from fabrics (safe on colors!), bath tubs, sinks, toilet bowls, chrome fixtures. Makes rusty auto bumpers look new again. Loosens rusty nuts and bolts. No rubbing, no scrubbing.

No. 120—Rust Remover \$1.59
Mailing 15c Each

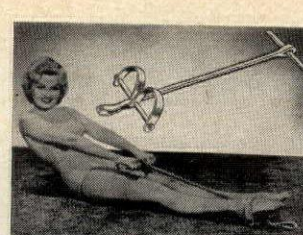

STRETCH TO HEALTH & BEAUTY

Get slim—keep slim. Develop muscle tone. Enjoy vigorous health through exercise. A few minutes each day on this rubber "rowing machine" provides scientific exercise for men and women. Includes big, illustrated chart for exercises.

No. 144—Rowing Machine \$5.98
Mailing 95c Each

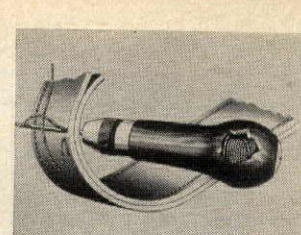

SEW ANY HEAVY MATERIAL

Handiest tool for sewing leather & canvas. Save money. Do your own repairs on awnings, seats, upholstery, shoes, sails, auto tops, hand bags, etc. Sews lock stitch. Includes bobbin of waxed thread, 3 diamond point needles. Extra thread, 50c.

No. 126—Sewing Awl \$2.98
Mailing 20c Each



WIPE AWAY BURNT-ON GREASE

New miracle cleaner for aluminum, chrome, porcelain. Dissolves carbonized grease and encrusted build-up fast from frypans, waffle irons, stove, oven, rotisserie, grill, etc. Will not darken or pit utensils 7 oz. can with brush.

No. 104—Carbon Cleaner \$1.98
Mailing 30c Each

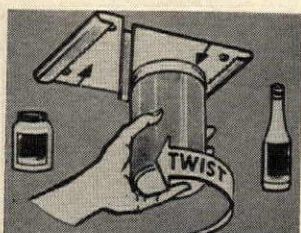

UNDER-SHELF JAR OPENER

No jar or bottle—large or small—can stay sealed when grasped by the notched steel edges of this amazing opener. Permanently installed under shelf or cupboard. Works quickly, safely—with no effort. Screws included.

No. 123—Under-Shelf Opener \$1.98
Mailing 30c Each

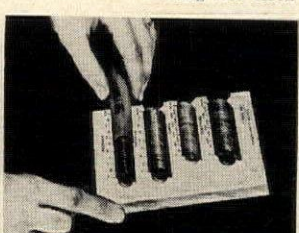

COUNT COINS FAST!

Sort, count, wrap pennies, nickels, dimes, quarters in seconds. Simply slide coins into 4 channels. Shows the totals as you go. No more fumbling with the wrapper. Real time-saver for merchants, cashiers, clubs, collectors, etc.

No. 102—Coin Counting Tray \$1.98
Mailing 30c Each



GLAMOUR SLEEP BRA

For undreamed comfort in nylon stretch lace for curve caressing control and feminine flattery. Ideal for sleep, gardening, golfing or just lounging. Snap front closure for dressing ease. White, A-B or C-D.

No. 128—Sleep Bra \$2.98
Mailing 20c Each



SCRATCHES VANISH INSTANTLY!

One stroke of the "Almond Stick" and superficial scratches disappear from pianos, furniture, woodwork, etc. Works wonders on Mahogany, Walnut, Oak, and other fine finishes. Used professionally by furniture dealers and movers.

No. 119—Almond Stick \$1.59
Mailing 15c Each



TOO MANY "CHINS" SHOWING?

A trim chin is a sign of youthful beauty. Treat your chin to the luxury of a Hollywood Chin Band. Wear it while you sleep, read or watch TV. You'll be amazed at the results. Fine latex with adjustable headband for proper tension.

No. 155—Chin Band \$1.49
Mailing 15c Each

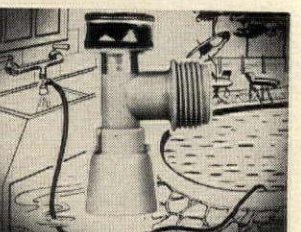

LOW-COST WATER PUMP

Why pay a lot of money for a gasoline or electric pump? Your home water pressure operates this handy little worker. Simple syphon principle empties up to 360 gallons per hour from flooded basements, pools, washing machines, boats, etc.

No. 160—Siph-O-Water Pump \$3.98
Mailing 30c Each

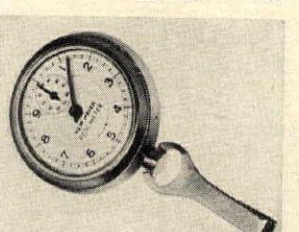

HOW FAR DID YOU WALK TODAY?

This precision-made *Pedometer* measures every step you take! Just set it for your stride, hang it from your belt. Registers up to 100 miles. Perfect for housewives, sportsmen, hikers, scouts, convalescents, etc. Fully guaranteed.

No. 207—Pedometer \$7.98
Mailing 35c Each



AUTOMATIC NEEDLE THREADER

Just drop a needle into the plastic funnel, press button, and presto the needle is threaded. Has spindle to hold spool of thread, plus built-in thread cutter blade. Saves eye-strain. Ideal for older people.

No. 163—Needle Threader \$1.00
Mailing 15c Each

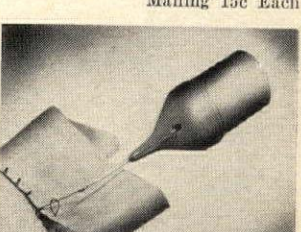

A MACHINE FOR HAND SEWING

A brand new device to make hand-sewing easy! No re-threading. It holds a full spool of thread. Uses regular sewing machine needle. Makes "loop" stitch, as in knitting. Perfect for hemming, basting, applique, decorative stitching, etc.

No. 151—E-Z Stitcher \$1.29
Mailing 15c Each

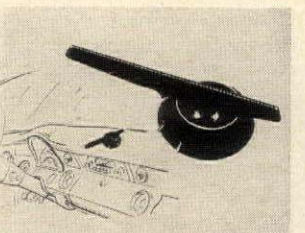

PARK YOUR CAR IN A JIFFY!

Ends guesswork, frayed nerves and scraped fenders. Fits any type car. Makes parking easy—even in the tightest spots. Adjust according to directions and park perfectly the first time—every time! Used by many driving schools.

No. 103—Car Parker \$2.98
Mailing 20c Each

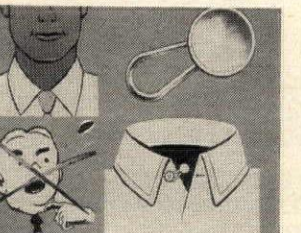

END SHIRT COLLAR "SQUEEZE"

Collar-Extender button "loosens" tight shirt collars. Ends all-day "tugging". Expands collar up to 1/2 size larger for that "just right" feeling. Invisible behind tie. Can be transferred from shirt to shirt in seconds.

No. 114—Collar-Eze (Set of 2) \$1.00
Mailing 15c

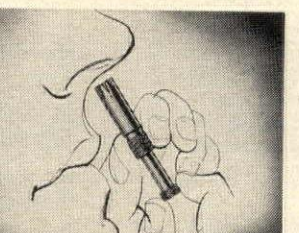

DON'T PULL HAIR FROM NOSE!

Why risk infection? Unsightly hair can be trimmed easily and safely with "Groomette". Merely insert in nostril and twist knob. Hair is snipped off painlessly and neat. Fine surgical steel. Use it to remove hair from ears, too.

No. 145—Groomette \$1.59
Mailing 15c Each



DRY CLOTHES—RAIN OR SHINE

"Drip-Dri Bar" hooks over shower rod and locks in place. Attaches in seconds. No screws, no adhesive. Can't mar wall. Adjustable 25"-31". Fits any standard bathtub. Holds full-length garments. Water drips into tub, not on the floor.

No. 131—Drip-Dri Bar \$3.98
Mailing 35c Each

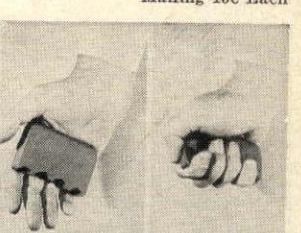

MUSCLE TONER

A wonderful exercising aid made of firm resilient rubber with space for each finger, designed to strengthen hand and arm muscles. Also recommended by doctors for relief from arthritic pain, aches and stiffness.

No. 106—Hand Exerciser \$1.98
Mailing 15c Each

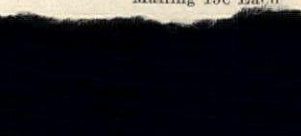

Picture . . . "COUNTRY CHARM" EARLY AMERICAN APPLIANCES . . . and You!

AUTOMATIC ELECTRIC RANGE . . .

. . . authentic **CAST IRON** reproduction from original patterns. Combined with the Early American charm of this handsome antique is the convenience of fully automatic oven and burner controls, and an easy-care porcelain top. Coffee mill uniquely houses clock, oven timer and minute minder. Fits modern range space. Prices start at **\$435.00**, plus freight charges.

CAST IRON WALL OVEN . . . (inset)

Front is **CAST IRON** with handsome scroll design. The 18" oven is fully insulated and porcelain lined. Hearth door conceals all controls, clock and timer. Available in right or left hand door models. Prices begin at **\$267.50**, plus freight charges.

Quality Backed by 35 Years of Skilled Craftsmanship.



FREE "Country Charm" Appliance Folder Upon Request

Made and Sold Only by
THE HOUSE OF WEBSTER
"Old Fashioned Gifts"
BOX HG-1071 ROGERS, ARK. 72756

SHOPPING AROUND



SEW HANDY

Headquarter sewing gear in a handsome Chippendale unit that doubles as an end table. It opens to 12 sq. ft. of work space. Bins and drawers aplenty for machine *et al.* Pine finished in honey, maple, antique pine or antique maple. Open, 72" w., 24" d., 30" h.; 37½" w. closed. \$79.95; kit, \$59.95. Exp. coll. Yield House, HG10, No. Conway, NH 03860.

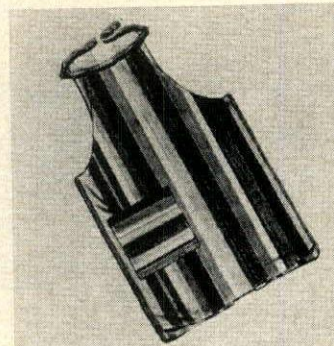

SPRIGHTLY STRIPES

"Pleasure Put-On" apron of lively Roman stripes in rust, gray, black, white and yellow has an adjustable halter neckline with snap closing that fits anyone! Fabric is wrinkle-free Fortrel polyester cotton and comes in generous 28" or 34" lengths. \$7.75; or two for \$14.50. Ppd. Aquarius Enterprises, HG10, Box 76849, Los Angeles, CA 90005.



HAND-BLOWN THISTLES

Borrow a lovely idea from German and Bohemian past—thistle glasses. Gracious, graceful hand-blown bowls now made in U.S. 11 oz. for table wines, 5 oz. for after-dinner sipping. Set of six wine glasses, \$14.95; set of six brandy, \$13.95. Ppd. Free catalogue of many wine glasses. Wine Glasses, HG10, Box 732, Sausalito, CA 94965.

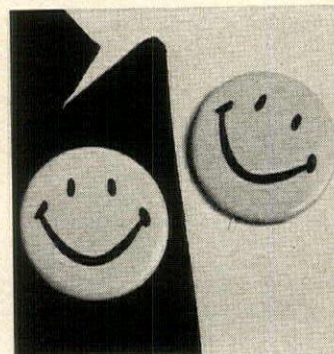

SMILE FOR PRESIDENT

We agree that the favorite candidate in '72 will surely be the guy who sports a smile button on his lapel. Each button is 2½-inches in diameter and is in warm *day-glo* colors to keep everyone smiling no matter what comes along. Two, \$1 ppd. Anthony Enterprises, HG10, 585 Market St., San Francisco, CA 94105.



Paint me. Stain me. Mix me with anything. The solid beech frame of our Louis XV Arm Chair is ready to finish any way you like. Caned seat and back. H 37", W 23", D 20". St. Ht. 17¼". \$97. Side chair, \$81. Exp. Chgs. Col. No COD's. 56-page catalog, \$1.

3140 M St. N.W. (HG) Wash. D.C. 20007

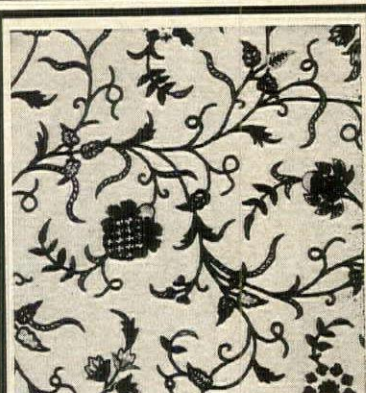

Hand-Embroidered Crewele from India IMMEDIATE DELIVERY

Graceful multi-colored floral pattern is hand-embroidered in wool on natural hand-woven cotton from Kashmir. Perfect for elegant draperies, upholstery, etc. From importer at tremendous values! 50" wide, \$9.95 per yard, post-paid.

Crewele Bedspreads: Twin \$50; Full \$60; King \$80
Crewele Tablecloths: 70" Rd. \$36; 90" Rd. \$45
Crewele Pillow Covers: 12½" square or round \$5.00 each.

NUMDAH RUGS 2x3 \$5.00; 3x4 \$10.00;
4x6 \$20.00; 3' round \$10.00 ppd.

Send 50c in coin for swatch and COLOR CATALOG

GURIANS, 11 East 33rd Street
Dept. HG-10, New York 10016



Send for
FREE



COMBINATION PEPPER MILL and SALT SHAKER

Gracefully styled, this exceptionally attractive piece comes in light Pewter that shines like silver but



WRETCHED MESS CALENDAR

What's cheerier than a month full of laughs? At least *you* are bound to, wherever you look at this calendar. Making a play on words turns Jan into Genieway and Feb into Frigiduary. A Horridscope is part of the deal. With "wroom to write," 8½" by 11" folded. \$2 ppd. Bruce Bolind, HG10, Boulder, CO 80302.

Showcases for the Achievers

SHOPPING AROUND

VICTORIAN BELLE

Charming loveseat with sweeping hand-carved top rail is made of solid mahogany. The back and sides are hand-tufted; fully sprung base with web bottom. 39" l., 23" d., 33" h. Variety of fabrics available. \$189.95. Exp. coll. Victorian catalogue with fabric samples, \$1. Magnolia Hall, HG10, 726 Andover, Atlanta, GA 30327.



WHAT'S HER SIGN?

The zodiac appeal is greater than ever. Now you can pick out 18k gold rings with the proper sign as the emblem—shown here is Pisces. Measure around her finger with a piece of string, set the string on a ruler for number of inches—important because ring has closed back. \$25 ppd. Heraldica Imports, Dept. HG10, 21 W. 46th St., New York, NY 10036.



19TH HOLE PICK-UP

Great set-up for a favorite four-some—four hollow balls, four tees plus an extra. Each ball is hollow and holds an ounce and a half of a pick-me-up to make the golf game bracing even before the famous 19th hole. \$1.98 plus 20c postage. Order from Anthony Enterprises, HG10, 585 Market St., San Francisco, CA 94105.



THREE'S A TEAM

That comes in mighty handy for extra seating, as end tables or to rest weary feet. Nesting taborets are natural rattan, light but remarkably sturdy. Large, 18" h., 16" dia.; medium, 17" h., 14" dia.; small, 16" h., 13" dia. Set of three, \$24.95 plus \$2 post. Catalogue, 25c. Fran's Basket House, HG10, 89 W. Main St., Rockaway, NJ 07866.



WEATHER WISE

When fair weather is in store the children come out, for rain or snow it's the old witch. The chalet they live in is gingerbread as they come, of marble-look plastic right for any wall. Fun and so useful. Thermometer, too. 5 3/4" by 4 1/2" by 1 1/2" deep. \$1.98 plus 20c post. Order #142. Anthony Enterprises, HG10, 585 Market St., San Francisco, CA 94105.

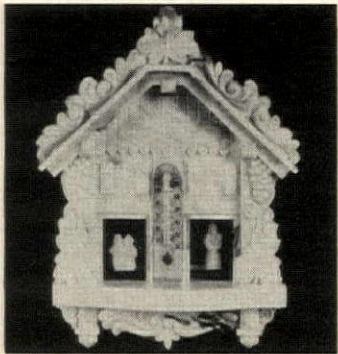

ORIENTAL DESIGN RUGS.

breathtaking patterns from time immemorial, that blend so perfectly with modern decor. Capture the romanticism of the alluring East into your living room, dining room, bedroom, foyer, den, office or showroom. Transform any drab area into a charmingly elegant setting. Exquisitely beautiful designs painstakingly woven into the back of the rug, out of natural yarns only. Will last longer than most rugs you have ever had, due to their sturdy construction, yet are soft and cozy under your feet. Require very little maintenance. Hide all spots and stains. Guaranteed imported. Cost?—The last real home-decorating bargain in this age of spiralling costs. AS LONG AS SUPPLY LASTS: approx. 4' x 6' \$17.95 ppd.; 6' x 9' \$33.95 ppd.; 8' x 10' \$49.95; 9' x 12' \$59.95; 9' x 15' \$89.95. But you must act now. Specify red, ivory, Wedgwood blue or green background. Prompt deliveries. Make ideal X-mas gifts. Our 35th year of proven reliability.



INTERNATIONAL RUG CO.

360 Amsterdam Avenue New York, N.Y. 10024

NOW EVERYBODY CAN BUY THEIR OWN EXTRA PHONE WITH NO RENTAL CHARGE AT ALL

Complete with 4-PRONG PLUG, RINGER, REGULAR CORD
Just plug it in! Nothing else to buy!

These well-made, top brand name standard dial phones are completely reconditioned by experienced factory-trained repairmen... rewired, refinished and inspected down to the last service detail. Each is READY-TO-USE, WITH RINGER, 4-PRONG PLUG AND CORD. There is nothing else to buy. Great as that extra phone... or 2-phone intercom system... in office, den, kitchen, bedroom, etc... and it costs you less to own it yourself than what you have to pay in one year's rent!



ON SALE—NOW ONLY 995

CHOOSE ANY PHONE YOU LIKE AND OWN IT—NO RENTAL CHARGES TO PAY EVER

 <p>COLOR PHONES with Bell Available in Red, Blue, Green, Yellow, White, Beige, Ivory, Pink, Black, Gold\$16.95</p>	 <p>ANTIQUe CRADLE PHONE (Vintage 1928) Antique Cradle Phone. Green, Yellow, White, Beige, Blue, Red, Pink, Gold, Ivory and Black\$22.95</p>	 <p>HANGER PHONE With Dial \$17.95 No Dial \$11.95 Black Only</p>
 <p>FRENCH CRADLE PHONE From Milady's boudoir. In Ivory, complete with bell and plug-in\$49.95</p>	 <p>COLOR-WALL PHONES White, Beige, Ivory, Green, Red, Blue, Black, Pink, Gold and Yellow\$22.95 includes bell</p>	 <p>UPRIGHT PHONE From the Days of Eliot Ness. Black with Brass Trim \$49.95 Brass with Black Trim \$59.95</p>
 <p>ERICOPHONE The famous European phone with the dial on the bottom. Lift, it is ready to dial or answer, set down and communication is cut off. The phone for style—Red, Ivory, Beige, White, Blue, Green, Yellow. With Buzzer\$49.95 With Tweeter\$59.95</p>	 <p>MODERN STANDARD COLOR PHONES Green, Blue, Pink, White, Ivory, Red, Beige, Green & Yellow, Blk. with bell. \$23.95 #500—Later Model \$29.95 Choice of Colors</p>	 <p>PRINCESS TYPE "STARLITE PHONE" Pink, Beige, Blue, Green and White, Ivory. Complete with Bell and Light \$39.95 BARONESS—White only with bell\$29.95</p>

GRANDCOM, INC., Dept. HG-10
1152 Sixth Avenue, New York, N.Y. 10036

Send me _____ phones as listed below: _____

SEND FOR FREE CATALOG
Hundreds of other phones available

Name _____ Shipping Charges \$ _____
Address _____ Tax if any \$ _____
City _____ State _____ Zip _____ Total enclosed \$ _____

Enclose check or Money Order. No C.O.D.'s

_____ \$ _____
Add \$1.50 shipping and Handling Charge for each phone ordered east of Mississippi.
\$2.00 for each phone west of Mississippi.

HUMOROUS DESK PLAQUES

It's hard to be
humble when you're
as great as I am

Gold-colored metal Desk Plaques in black lettering on stained wooden stand, 2 1/2" x 4".

Titles:

- _____ It's hard to be humble when you're as great as I am
- _____ Nobody's Perfect but me
- _____ Sales Mangler
- _____ Silence! Genius at work
- _____ Stupidvisor
- _____ Ulcer Dept.
- _____ Order Mistaker
- _____ Big Boss
- _____ Chairman of the Bored
- _____ Off Duty
- _____ Please! I'd rather you did it yourself
- _____ Temporarily out of service
- _____ I'm new here myself
- _____ What makes you think I work here
- _____ No Spika Da English
- _____ Inquire next Desk Please
- _____ I'm Still on my lunch hour
- _____ I never get lost, everyone tells me where to go
- _____ Tell it to my Psychiatrist He gets paid to listen
- _____ This Section Closed
- _____ Be reasonable—Do It my way

\$1.98 each + 25c Mailing Each

Calif. residents add 5% sales tax.

Anthony Enterprises

Dept. HG-101

585 Market St., San Francisco, Calif. 94105



SUPER-WOK with stand and dome lid \$3.98

The fabulous Chinese Wok—now better than ever! Deep dome lid assures proper saute-and-steam method for delectable dishes—the stand holds pan steady and secure, guarantees even heat. Authentic centuries-old design is the secret of cooking mouth-watering Oriental delights at home—AND the secret of low-calorie results, because you use mere drops of oil or water. 12" steel pan, recipes included.

#6389 Super-Wok\$3.98

Please add 75c post. & hdlg.

"THE PLEASURES OF CHINESE COOKERY"

By Grace Zia Chu—a treasure trove of healthful, tasty, budget-wise dishes. 192 fabulous pages. #6498\$1.45



The Country Gourmet Inc.

Dept. G0, 545 Fourth Ave., Mt. Vernon, N. Y. 10550



Madonna

A remarkable piece of work from the artisans of Bohemia to be treasured and enjoyed. A reproduction of the famous painting "Madonna of the Chair" is skillfully etched in crystal. With light shining through, the detail and expressions stand out with great clarity and beauty. 4 1/2" high.

\$6.95

Add 65c post. and handling

Pa. Res. Add 6% Tax • Sorry No COD's
SEND 25c FOR GIFT CATALOG

Clymer's of Bucks County

Dept. HG10-1, Point Pleasant, Pa. 18950



STUDY INTERIOR DECORATION

- 4 Month Practical Training Course
- 3 Year Course in Interior Design
- 6 Week Summer Session

Classes start Sept., Feb. and July

Approved by Bd. of Regents of the Univ. of the State of N.Y. Send for Catalog 11R.

HOME STUDY COURSE STARTS NOW.
Catalog 11C.

**NEW YORK SCHOOL OF
INTERIOR DESIGN**

155 East 56th St., N.Y. 10022



"LI'L BUTTONS"

A little boy or girl just learning to dress will be enchanted with this play-and-learn doll. Dressed up in clothes that unbutton, unzip, unbuckle, snap up, tuck in, untie. Doll is 16" tall.

\$6.95
Plus 95c postage

FREE CATALOG

CREATIVE HOUSE

221 W. 9th St. Kansas City, Mo. 64105

SHOPPING AROUND

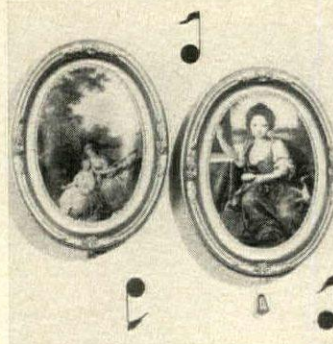

SETTING A NEW TONE

Brilliantly printed silk pictures are reproductions of famous European paintings with a different note—they're musical. Set in 8" gold-framed plaques, Hilair plays "Raindrops Keep Falling on My Head;" Mignard is "Spanish Eyes" or "Somewhere My Love." \$16.70 ppd. Catalogue, 50c. Hildegard's, HG10, 597 Farmington Ave., Hartford, CT 06105.

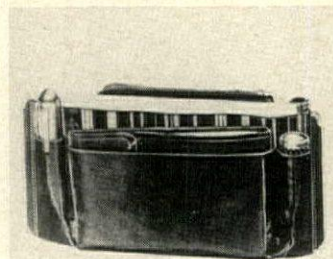

HELP'S AT HAND

Changing handbags is hazardous, especially if you like to tote a bureau drawer's worth of gear. If you insist, at least be wise with a purse organizer—seven pockets help keep order. In multi-toned fabrics. 7" by 3 1/2". \$1.29 plus 15c post. Anthony Enterprises, HG10, 585 Market St., San Francisco, CA 94105.



STAFFORDSHIRE SET

As gay and nostalgic as calico, this flower-strewn bowl and pitcher add period charm to bedroom, bath, any room. Fine English Staffordshire china in blue or brown. Eight oz., \$6.95; 20 oz., \$12.95; 32 oz., \$14.95. Ppd. Another elegant gift imported for you by Jenifer House, Dept. HG101, Great Barrington, MA 01230.



FEATHER YOUR BED

Now there's a way to combine an old-fashioned down comforter with regular fashionable no-iron sheets and pillow cases. Change bedroom décor by changing sheets. Prices from \$89 (twin) to \$139 (king). A free color brochure shows how. Send 50c to Scando-Duo Inc., HG10, 1414 E. Olive Way, Seattle WA 98122.

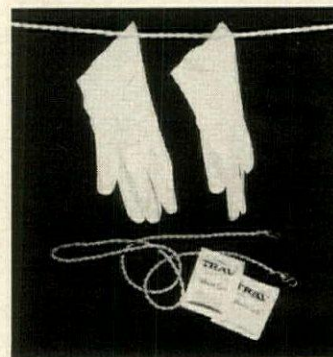

TRAVELER'S TREASURE

Clothes line to string up wherever travels take one requires no clothespins—just lay stockings or bras over, use hangers for slips, shirts and such. It stretches about 45"—room enough for a journeying family. Two packets of detergent included. \$1.29 plus 15c post. Anthony Enterprises, HG10, 585 Market St., San Francisco, CA 94105.



MONOGRAM BASKETS

Take a handsome basket, add your monogram in needlepoint, tie on a pretty ribbon and bow, and you've created something fashionable and uniquely yours. Complete kit includes basket, tapestry yarn, chart and canvas for monogram, easy instructions, and choice of a rose, gold, brown, blue, black, red, or green velvet ribbon.

HANDBAG KIT with 12" x 8" x 6 1/2" high Madeira basket \$4.95

HANDBAG KIT, same size, with straw lid\$5.95

WASTEBASKET KIT with rattan basket, 11" dia. x 10" \$4.95

Plus 50c postage each item. Pa. Res. add 6% sales tax. Sorry no COD's.

VICTORIA GIFTS
12-H Water St., Bryn Mawr, Pa. 19010



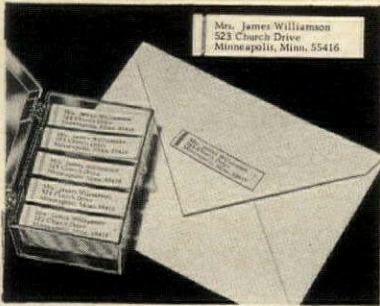

Mr. James Williamson
523 Church Drive
Minneapolis, Minn. 55416

Handy Name and Address Labels
Your name, address and zip code are on labels made of fine white or gold gummed paper. Use them to personalize checks, envelopes, records and packages! You may have up to four lines of type in sharp black on the 1 7/8" long labels. Both are in pad form in a plastic box. **RF365-6**—White, 1 pack of 1000, \$1 **RF452-6**—Gold, 1 pack of 500, \$2

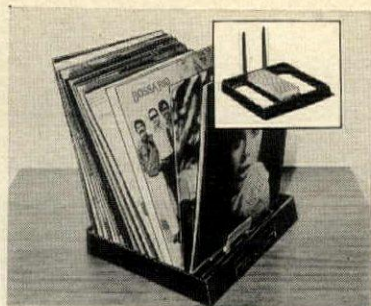

Self-Shuffling Record Selector
If this isn't magic—we'll eat our top 20 albums! Record Selector holds 24 LP albums and flips them forward automatically, one at a time, so you can read titles! Stop it whenever you like. Runs without motors or springs. Stops automatically at an empty slot to let you replace an album! Walnut plastic, 10 1/2"x12". **5070-6**—Record Selector . . . \$3.98



Grayline Garbage Bag Caddy
This space saver comes to you when the cabinet door it's mounted on is opened. Ends stooping and bending and is conveniently out of sight when door is closed. Steel rods have washable, rustproof cushion coating. Holds both grocery and plastic garbage bags out of sight but in easy reach. 6x12x13 1/2". With screws. **7316-6**—Bag Caddy \$2.98

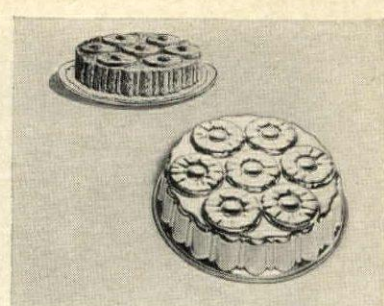

Upside-Down Cake Mold
You make picture-perfect pineapple upside-down cakes every time because this mold is indented to keep seven slices exactly in position. Anodized aluminum pan is coated with wonderful Teflon so nothing can stick—ever! Try molded gelatin salads and caramel-pecan rolls, too! Two-quart mold is 2x10". **7523-6**—Cake Mold \$3.69

Enjoy Personal Service right to your door...

Our merchandise is backed by an old-fashioned guarantee that insists upon your full satisfaction or a quick quibble-free refund. Courtesy and integrity of yesteryear have made us many friends in all of the 50 states. We'd like you

to be among them. But, try us! Order anything on this page—we're sure you'll be pleased with our merchandise and our service. We'll be glad to hear from you. Sincerely,

Alberta Kimball

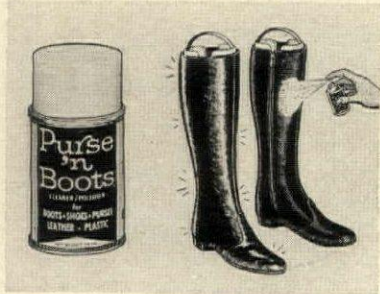

Purse 'n Boots Leather Care
Caretaker in a can for leather, patent and plastic—purses, boots, gloves, sports equipment and furniture! Lifts out soil and salt stains, softens the leather and brings out the rich grain and natural glowing lustre, and finally—waterproofs the surface. Four essential steps in one 3 1/2 oz. can! Not for buck or suede. **0283-6**—Purse 'n Boots \$1

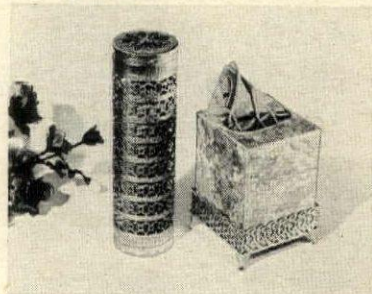

Tissue Holder, Spray Can Cover
Golden boutique touches for bathroom or dresser! Holder is sized to take a box of those pretty square pop-up tissues. It's 2" tall, 4 1/2" square, made of golden metal with intricate lacy trim. The same delicate metal openwork design is used in the spray can cover. It's 10x3". **0687-6**—Tissue Holder \$2 **0688-6**—Spray Can Cover . . . \$2.79



Miniature Punch Service
The prima donna of your miniature collection and an accessory to put any dollhouse in the Social Register! Here is exquisite handblown glass with a fiery brilliance. The 1 1/8" bowl rests on a 1 3/4" long silvery metal tray with filigree rim and mirror finish. Glass hooks hold four tiny punch cups. With ladle. **3236-6**—Punch Service \$6



Golden Monogram Pin
The art of monogramming—interweaving initials into unique designs—has fascinated man for centuries. Wear your own personal monogram in a 2x2 1/2" brass pin lavishly finished with 18K gold plate. Print plainly your three initials and underline the surname initial. All letters available except X. **XE520-6**—Monogram. Pin \$6

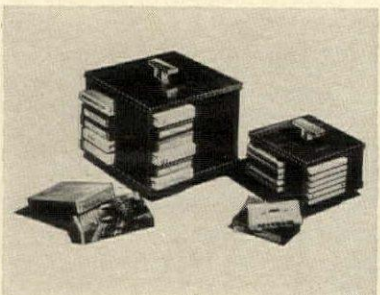

Stereo Tape Lazy Suzans
Tape Caddies have heavy-gauge molded plastic shelves, plastic base with the look of ebony, metal top with elegant walnut veneer finish and lustrous chromed handle. They twirl silently on steel ball bearings. The larger is 9 1/2" square, 9" high—holds 24 eight-track tapes. Smaller is 6 1/2" square, 5 1/2" high—takes 24 cassettes. Each has index labels. **5324-6**—Cassette Lazy Susan, \$9.98 **5325-6**—Eight-Track Susan, \$12.98

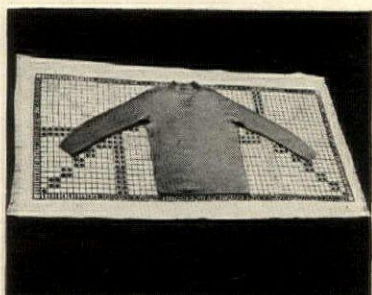

Blocking Towel by Dritz
A must for all women who wash knits! They won't stretch or shrink after washing when you have a blocking towel! Fluffy, beach-size terry towel has permanent, colorful inch markings and bias lines. Lay out the garment before washing, then place it on the same markings to dry. It absorbs moisture and is 35x60" to block even knit dresses. Full blocking instructions included. **5981-6**—Blocking Towel \$5

Free Catalog...

Check here to receive our new Fall catalog with 196 pages of fresh and exciting gifts, toys and housewares — each one fairly priced and guaranteed to please!



ITEM NO.	QUAN.	NAME OF ITEM	PRICE

Items on this page shipped postpaid. Total Amount Enclosed _____

Name _____

Address _____

City _____ State _____ Zip _____

Use this Order Form for the items on this page or to request Free Catalog. Send to:

Miles Kimball Company

236 BOND STREET - OSHKOSH, WISCONSIN 54901

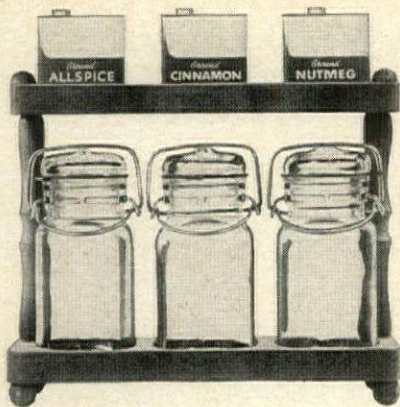

Spice & Everything Nice Rack



Carved like an old fashioned memory. Native wood, 8 x 10 inches. Comes with 3 olde tyme canning jars complete with vacuum-seal lids. Perfect for nuts and garlic. Top shelf for storing spice tins, too.

Stands on counter top or hangs on a wall. Send \$4.95 plus 80¢ postage. For Gifttime color Christmas catalog, add 25¢.

To: Damarc Products, Inc., Dept. HG-10
1515 N. Warson Rd., St. Louis, Mo. 63132

SHOPPING AROUND

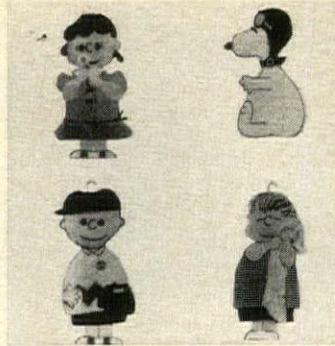

PORTABLE PEANUTS

Colorful carryalls feature felt appliques on sturdy cotton. Bag comes with hanger, stores laundry, p.j.'s, toys. Ideal for child's room or bath. 26" l. Choose Linus, Lucy, Charley Brown or Snoopy. Also Raggedy Ann or Andy. \$5.98; any two for \$11.50. Ppd. Brochure, 10c. The Marketplace, Dept. GE-10, 3357 W. 66th St., Chicago, IL 60629.

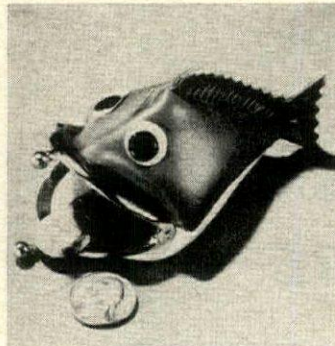

MINI MONEY MONSTER

Gilt-edged sea creature gobbles mad money. Metal jaws open wide for convenience. Reinforced white and red vinyl withstands wear and tear. Ideal for tokens, tolls. 4½" long. \$1 each plus 10c post.; two for \$1.98 ppd. Order a school-full for lots of Christmas stockings. Uni-Leisure, Dept. MPE-3, 20 Bank St., White Plains, NY 10606.

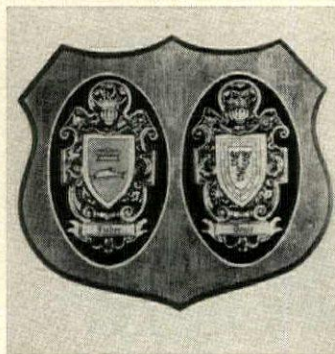

COAT OF ARMS

Handsome double Coat of Arms plaque for the bride and groom or an anniversary couple. Lineage of both husband and wife researched by heraldic experts, then handcrafted in England. In antiqued brass finish, on burgundy velour mounted on walnut finish. 17" by 14". \$49.95. Ppd. Canterbury Arms, Ltd., HG10, 125 Fifth Ave., NY 10003.



OPTIC OPERA AIDS

For those who hate to miss a move—folding opera glasses. Tiny enough to slip into any handbag or pocket. Sports fans, theatre buffs, and ballet bugs all love them. Makes balcony seats seem like first-row center! Chrome plated, 2.5 by 25 m/m. \$3.98 plus 20c post. Anthony Enterprises, HG10, 585 Market St., San Francisco, CA 94105.



PORCELAIN PETS

Tiny ceramic kitty and puppy snooze snugly in real woven wicker baskets! Imagine them on your bedside table or on a shelf near other little things! Wicker baskets are 2" long with raised sides and the delightful little sleepyheads are about 1¾" across. English imports! \$2 ea. ppd. Miles Kimball, 100 Bond St., Oshkosh, WI 54901.



MAKE MERRY MAILBOX

Needlepoint your way to Christmas and come on strong with an astonishingly festive basket for holiday mail. Hang it on mantle or door. Kit includes straw and canvas; red, green, gold tapestry wool; instructions. 9" by 5" by 6". Also with replica of air mail envelope. \$3.50 ea. plus 50c post. What's New Shop, 12H Water St., Bryn Mawr, PA 19010.

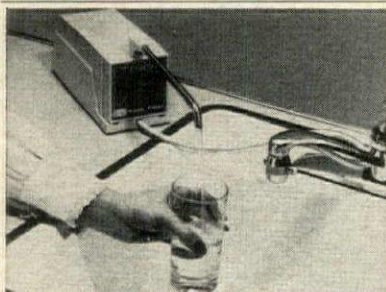

NOW— FILTER YOUR WATER DIRECT FROM THE TAP!

New EATON Activated Charcoal Water Filter gives you INSTANT mountain-fresh water. Inexpensive, replaceable cartridge needs changing only once a year—delivers hundreds of gallons of filtered water. Removes objectionable taste, odors, discoloration, chlorine and sulphur. Attaches in seconds to water faucet—WITHOUT ELECTRICAL CONNECTIONS. NO PLUMBING NECESSARY. Unconditional money-back guarantee.

Special introductory price \$24.95 complete. Send check or money order for \$24.95 to:

D & S EQUIPMENT CO.

Dept. A, 8110 W. Addison—Chicago, Ill. 60634

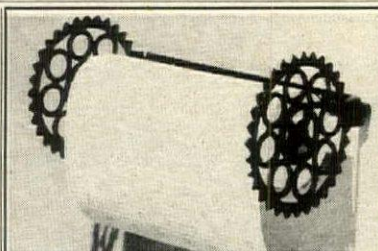

TRIVET TOWEL HOLDER

Ward off evil spirits in your kitchen with this charming paper towel rack, fashioned after famed Pennsylvania Dutch hex designs. 6" diameter cast iron trivets at either end. Rack holds jumbo or regular size roll of towels within easy reach. \$3.50 plus 45c postage.

KITCHEN UTENSIL RACK

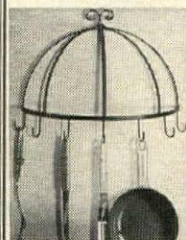

Stylish rack puts kitchen utensils at your fingertips. Copied from meat racks in French butcher shops. Has 7 sturdy hooks. Made of black wrought iron. 16"x-12"x7". \$3.50 plus 45c postage.

FERRY HOUSE Dept. HG-10
Briarcliff Manor, N.Y. 10510

Let "Gussie Grabbit" give you a hand!



For the countless times you rinse your hands in the kitchen — there's Gussie Grabbit, the stay-in-place hand towel. 100% terry, completely machine-washable, she loops over any rack, refrigerator handle, back of chair, etc. and fastens with a Velcro tab. Great for YOU — Rabbit Grabbit So grab Gussie. Available for Kids!

Colors: Avocado/Yellow, Blue/White, Turquoise/Yellow, Pink/White. Specify Colors — Also Specify "Gussie" and/or "Rabbit"

\$2.25 ea. 2 for \$4.00
3 for \$5.50 Postage Paid
Check or Money Order * No C.O.D.
Ohio residents add 4 1/4% sales tax

Carru Enterprises, 12434 Cedar Road
Cleveland Heights, Ohio 44106

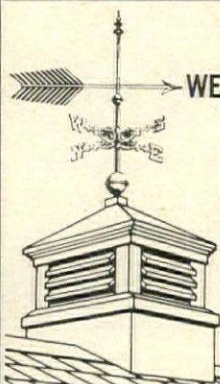

Fiske WEATHER VANES and Cupolas

Original Designs
AMERICA'S FINEST
FOR 100 YEARS
Established 1858

Fiske originals have topped homes for 100 years. Time does not dim their beauty or reliability. All are of hand-hammered copper, finished with 22k gold leaf. All are furnished complete with the four points of the compass.

Fiske offers a wide range of handsome ready-built cupolas. Write for catalog.

Vane illustrated . . . #131
ARROW, 24" long. Price \$49.



#200 ETHAN ALLEN, Jr.
HORSE ¾ full-bodied,
26" long. Price \$105.



#55 EAGLE
WITH ARROW
Full-bodied,
20" wing
spread.
Price \$116.

#332 ROOSTER, ¾
full-bodied, 13" high.
Price \$54.

Prices F.O.B. point of shipment
Write for Complete Weather Vane and Cupola Catalog.
J. W. FISKE ARCHITECTURAL METALS, INC.
113 Pennsylvania Ave., Paterson 3, N.J.

18 DECORATIVE CERAMIC TILES FROM ANTHONY ENTERPRISES

White Ceramic Tiles used as wall plaques or trivets. Cork base with hanger, 6" x 6". Designs will not wash off.

\$3.98 Each + 40¢ Mailing Each

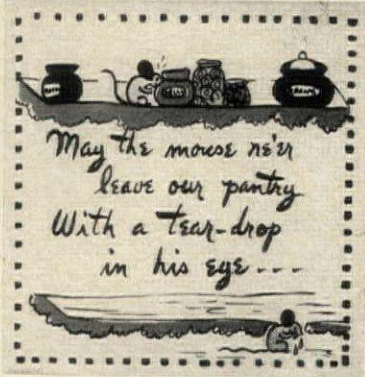

510 Pantry

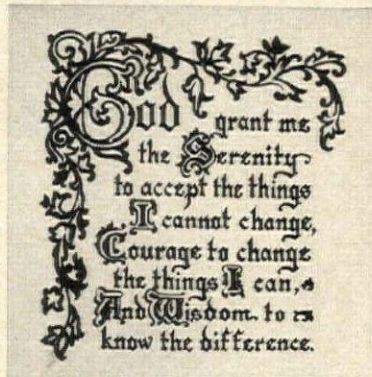

191 Serenity Prayer

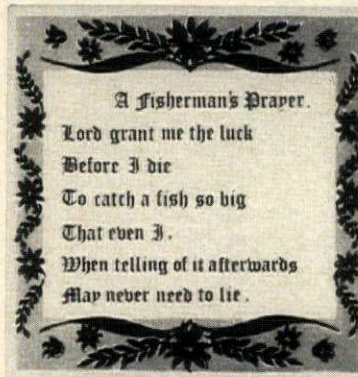

508 Fisherman's Prayer

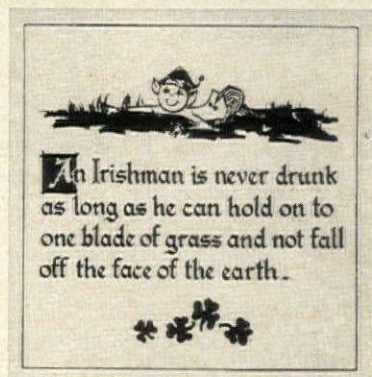

193 Irish Tippler

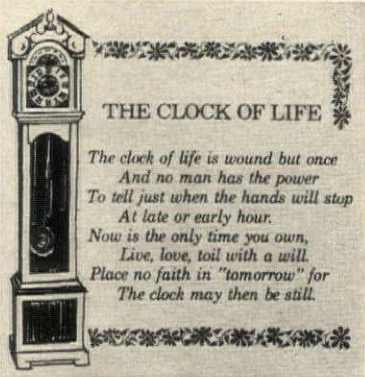

192 Clock of Life

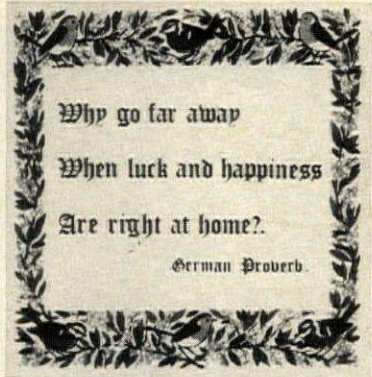

511 Happiness

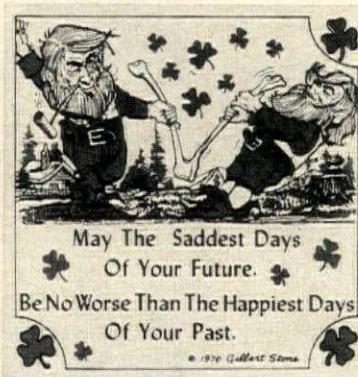

501 Irish Wish

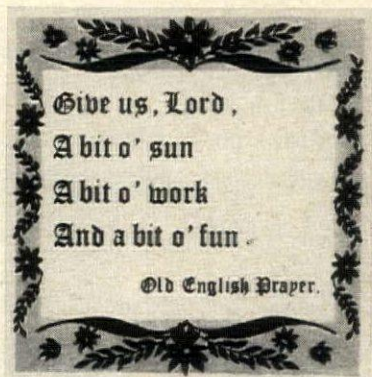

514 A Bit O' Sun

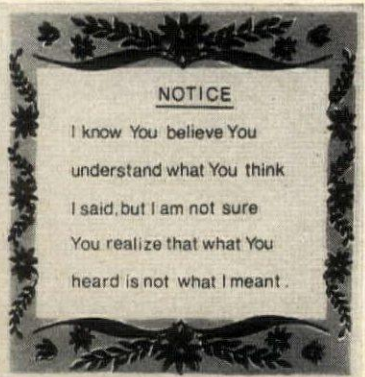

507 Notice

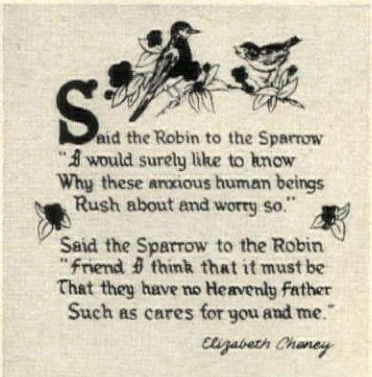

504 Robin and Sparrow

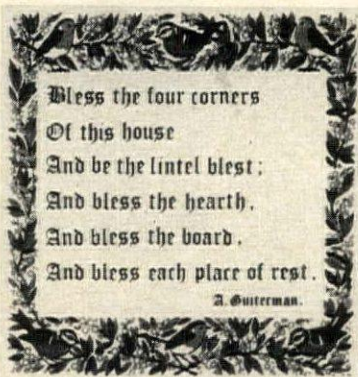

515 House Blessing

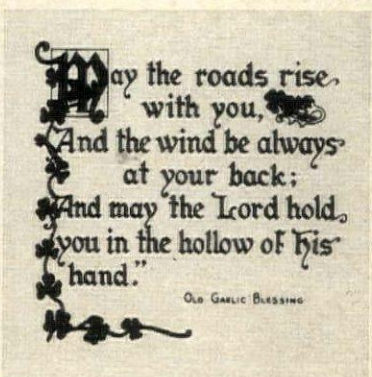

194 Gaelic Road

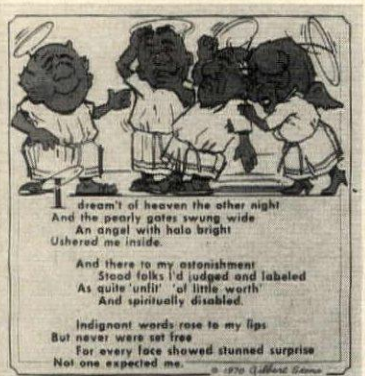

503 Dream of Heaven

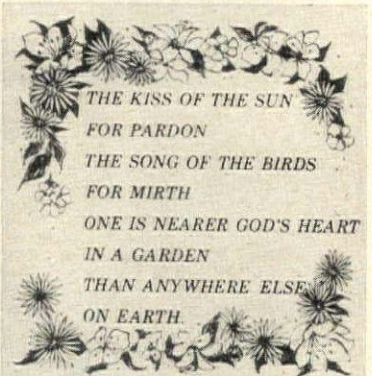

505 Kiss of Sun



502 Good Lord

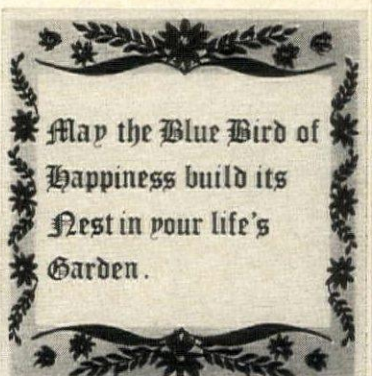

509 Blue Bird



513 Bird Song

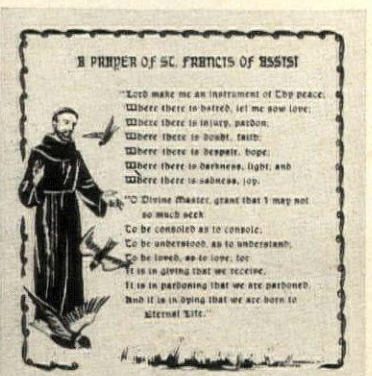

506 St. Francis Prayer

Anthony Enterprises 585 Market, Dept. HG-101 San Francisco, Ca. 94105		Name _____	Address _____	
		City & State _____	Zip _____	
Tile No.	How Many	Name of Tile	Price Ea.	Total
			\$3.98	
			\$3.98	
			\$3.98	
			\$3.98	
			Total	_____
NO STAMPS OR COD's, PLEASE				
SATISFACTION GUARANTEED OR MONEY BACK!		California residents add 5% Sales Tax		
		Mailing Charges—40c each tile		
TOTAL AMOUNT ENCLOSED _____				

OLD FASHIONED HANDCRAFTED IMPORTS



DELUXE DOLL HOUSE

Magnificently crafted by hand of fine hardwood, 1/2" thick. 5 rooms plus attic, staircase, wallpaper, etc. On ball-bearing wheels. All assembled, ready to furnish. 31" long, 23" high, 14" deep.

3359\$75

FREE 48 Pg. CATALOGS with order, or send 25c

48 page Doll House Furniture & Accessories plus 48 page Old Fashioned Toys, Dolls, Games, Books, Puzzles, etc.

We pay postage
Satisfaction Guaranteed
No cad's
N.Y. State residents add sales tax

FEDERAL SMALLWARES CORP. Dept. 13, 85 Fifth Ave., New York, N.Y. 10003



ANTIQUA REPLICA "JENNY LIND" DOLL
Genuine porcelain. Fully jointed, meticulously costumed by hand with lace-trimmed petticoat and pantaloons. A beauty! 8".

3512\$4.75



PORCELAIN BATHROOM SET

Exact miniature replicas of the old fashioned originals. Tub and sink have faucets; toilet has pull chain.

3651 Sink\$2.25
3648 Tub\$2.50
3656 Toilet\$2.50

All 3 for \$7.00

CHERRYWOOD ROLL-TOP DESK & CHAIR

Like the one Gran'pa had! Handsomely handcrafted. Top rolls down, gallery sections slides forward. For doll house, excels., etc. 4" x 4".

9212\$4.50 Set
2 Sets \$8.50

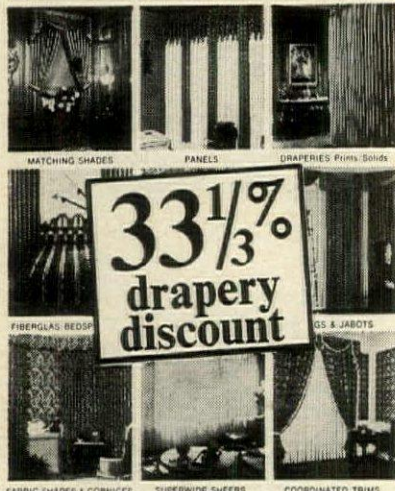

33 1/3% drapery discount

MANUFACTURER-DIRECT TO-YOU-DISCOUNT

We manufacture the world's largest selection of draperies, bedspreads and curtains. Ready-made and Custom-made. Buy direct and save 33 1/3%. Send for your FREE Ronnie Drapery Book today.

RONNIE DRAPERY CORP. Dept. 4L-13
145 Broad Avenue, Fairview, N.J. 07022



SPANISH PROVINCIAL CHAIRS, which suggest the antique but blend perfectly with classic modern interiors. Made by hand in Mexico, they have traditional Spanish peasant curving. Seat and back of handwoven rush; frame of sturdy Mexican wood. 37" h.; seat 18" w., 17" from floor. Choice of: Antique Charcoal Stain, \$30.00 pair. Unfinished Wood Frame, \$28.00 pair. Lacquered Frame, \$34.00 pair (lime, lemon, black, olive and white). **SPECIAL OFFER:** Deduct 10% on 4 or more chairs. (Express charges collect.) zN1354.

ELIZABETH McCAFFREY
Department HG-10C, Northport, New York 11768

TITANIA!

the most BRILLIANT JEWEL ON EARTH! says the Saturday Evening Post & READER'S DIGEST

about this amazing MAN MADE MIRACLE!



1 carat "Titania" Solitaire set in 14 kt. gold mounting. Complete. ONLY \$36

1 carat "Titania" set in a Mascu-line box style 14 kt. gold mounting. Complete. ONLY \$44

OUR 26TH YEAR!

Unset "Titania" jewels, 1 to 5 carats, for your own rings, brooches, pins, etc. \$15

Write for FREE HANDY RING SIZE CHART & 120 PAGE FULL COLOR JEWELRY CATALOG.

REGENT LAPIDARY CO. Dept. HG-10

511 EAST 12 ST., NEW YORK, N. Y. 10009



DATED NEWSPAPER COPY

Find out what happened the day you were born—or any other special date. You pick the date—any time from Jan. 1, 1900 through Dec. 31, 1964; you'll get the front page copy of the New York Herald Tribune for that day. Please specify exact dates. \$1.50 Ppd.

Write for FREE catalog of gifts.

Holiday Gifts Dept. 310-C
7047 Pecos St., Denver, Colorado 80221

SHOPPING AROUND

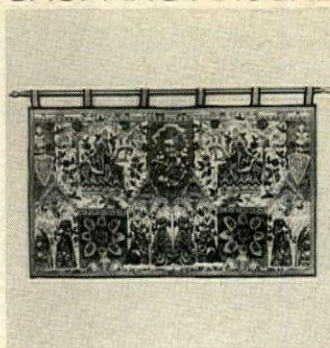

KNIGHT TAPESTRY

Magnificent tapestry with elegant quilted effect, 30" by 48" is worked in rose, blues and green with golden threads. The edges are gold brocade and velvet. Fabric is a cotton rayon blend that looks like artist's canvas. Rod not included. \$76.50 plus \$1.50 post. Lewis Import Mart, Dept. HG10, 125 Somerset St., North Plainfield, NJ 07060.



SHINING EXAMPLE

Start a campaign to end eye strain! Torch magnifier not only makes items look bigger, but brighter, too. Order several for the house, car, vacation home, everywhere. . . . Two junior size batteries make her shine. \$2.98 plus 25c post. from Anthony Enterprises, HG10, 585 Market St., San Francisco, CA 94105.



SET WITH JEWELS

Fabulous white glass candle holders imbedded with translucent jewels of brilliantly colored glass. When the candle is lighted the holders give off a rainbow of brilliance. 3" high and 2 1/2" dia. Perfectly sized for table or mantle. \$3.50 a pair plus 49c post. The Ferry House, Dept. HG10, Briarcliff Manor, NY 10510.



A TREE FOR ALL SEASONS

Paint a tree on wood and change it with the seasons after gay Christmas balls add dimension to your holidays. Abstract design is easy to follow, combines the new with the old. 11" by 15" wood panel, \$3.95. Plexiglass easel kit, \$4. Add 95c post. New catalogue 25c. Decorative Adventures, Dept. EG110, P.O. Box 228, Abington, PA 19001.

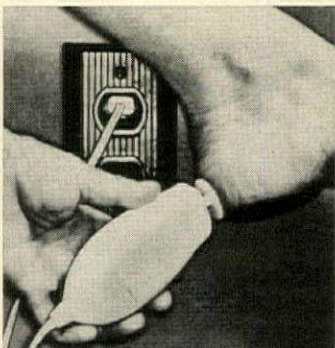

TOOTSEY GOOD BUY!

Electric callous eraser is a boon for smoothing corns, dead skin and tough callouses that have developed in the moil and toil of daily walking about streets, the byways and highways of day-to-day living. Eraser in white plastic case has 5 1/2' cord. \$3.98 ppd. Walter Drake, HG45, Drake Bldg., Colorado Springs, CO 80901.

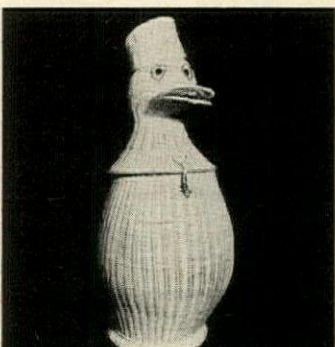

DONALD'S FRIEND

And a good pal to parents struggling to encourage kids to pick up toys and clothing. 30" high and 15" in diameter, Donald's pal holds a heap of toys in the kid's room or washbasin in the bathroom. Natural rattan with big eyes. \$18.95 plus \$2 post. Catalogue, 25c. Fran's Basket House, HG10, 89 W. Main St., Rockaway, NJ 07866.

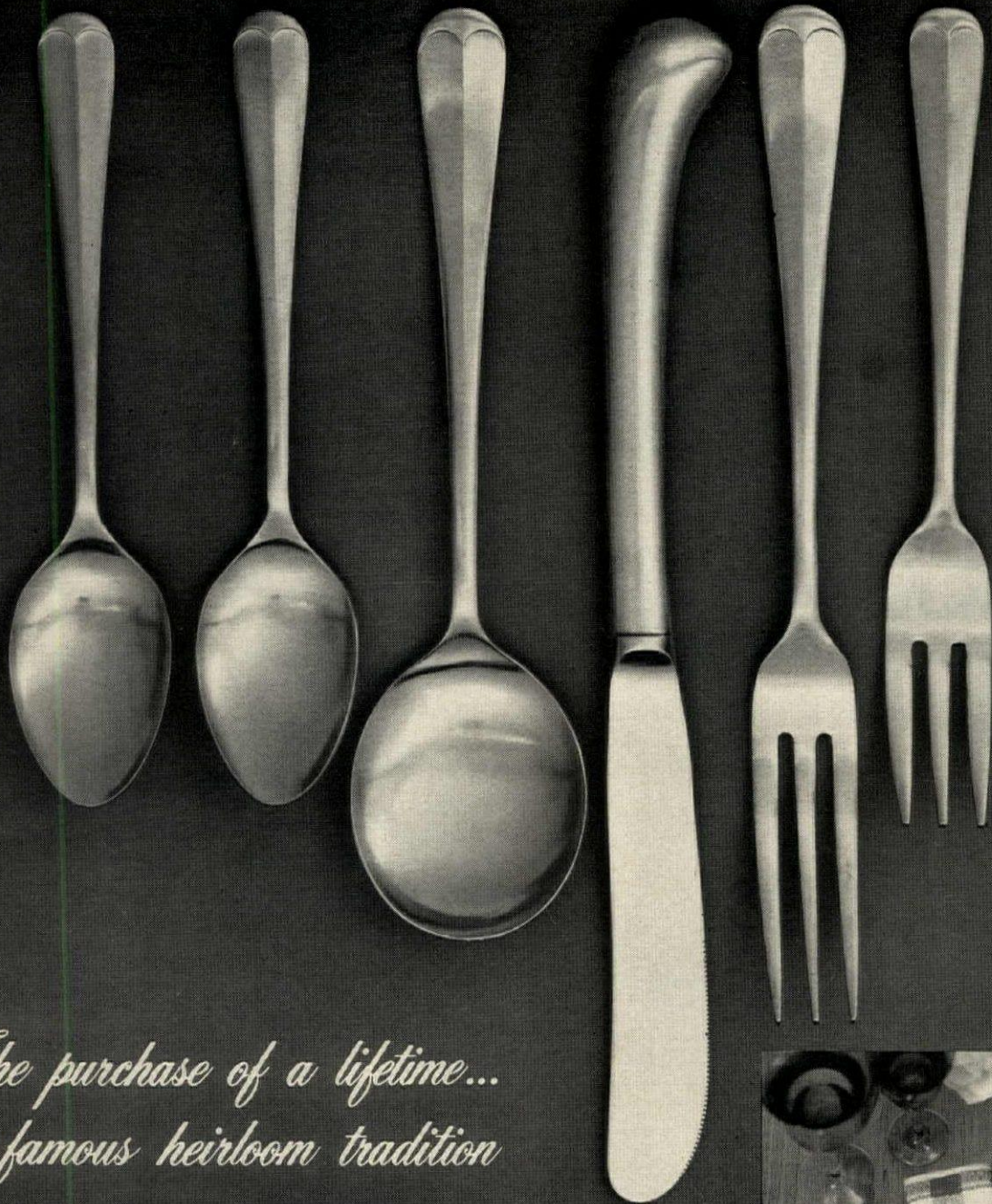

*The purchase of a lifetime...
In famous heirloom tradition*

**STERLING SILVER PISTOL-HANDLED
FLATWARE OF 1776...Reproduced as
authentic replicas in satin finish stainless**

Recreate the gracious atmosphere of Colonial elegance at your own table with this incredibly beautiful service...at just a fraction of what you might expect to pay for luxurious Sterling. Through a special purchase, we've been able to recreate the famous Pistol-Handled Flatware—a service that carries stunning simplicity of authentic Colonial—now in magnificent satin finished stainless steel. And every piece is a masterpiece—an exquisite replica of the famous Paul Revere settings that graced many a candlelight Colonial dinner. The knives are the genuine hollow pistol handles; there are extra deep bowls in the soup spoons; and the forks are the graceful 3-tined design. And because the entire set is in miracle stainless, you pop it right into the dishwasher without a care (and, of course, it never, never needs polishing!). At this special price, you'll no doubt want to give one as a gift to yourself and another to a cherished friend.

OFFER WILL NOT BE REPEATED THIS SEASON

Don't be disappointed, take advantage of this amazing low price now while this offer lasts. Order now, and we'll send you a complete service for 8 including 8 Dinner Forks, 8 Stay-Sharp dinner knives, 8 salad/lunch forks, 8 soup spoons, 16 teaspoons AND A SPECIAL FREE GIFT: 2 serving spoons—50 pieces in all. The entire set is yours for just \$14.98 on full money-back guarantee, but hurry, order now. This offer will not be repeated this season.

Copyright 1971 Division of Bevis Industries



Complete luxury service for 8

50 PIECES \$14⁹⁸
now only

COLONIAL STUDIOS, Dept. FPS-7
20 Bank Street, White Plains, N.Y. 10630
 Please send me the 48 piece Stainless Steel Pistol Grip 1776 Flatware set plus the 2 Free Serving Spoons for just \$14.98 on full money back guarantee if I am not absolutely delighted.
 (Please add \$1.00 postage and handling with each order.)

Enclosed is \$..... (Print Clearly)
 Name
 Address Apt. #.....
 City State Zip
 SAVE! SPECIAL OFFER: Order two sets for just \$27.98. Extra service makes a magnificent gift.



Satin P.J's . . .
to say 'thank you'
to your body. (Or
any body you know.)

What better way to reward a hard-working body than to lay it down to sleep in satin pajamas? Such comfort. Such luxury. Washable, too. Gold, Silver, Blue, Black, Olive, Red or Bronze acetate satin.

Ladies' sizes: 8-20. \$17.98.

Men's: Send height, weight, and waist measurements. \$19.98.

Monogram on either \$2.00.

SCINTILLA® SATIN SHOP

4802 N. BROADWAY G-10
CHICAGO, ILL. 60640

"All Things Exotic in Satin"

SHOPPING AROUND

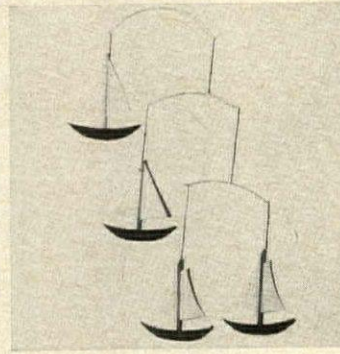

BOAT MOBILE

Bobbing boats take the breezes beautifully. It's all smooth sailing with a perfectly balanced mobile from Germany. Sailboat armada is hand-carved from natural wood, hulls are dark cork. 19" overall when hanging; four boats stand 5" high each. All aboard the breezes! \$5.75 ppd. Shopping International, Inc., Dept. 553, Norwich, VT 05055.

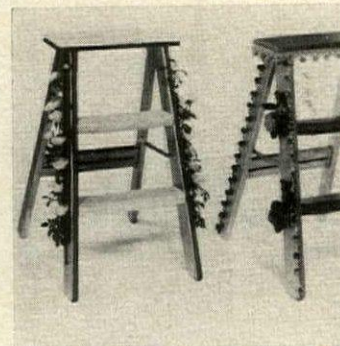

STEP RIGHT UP

Like library stairs, a ladder for your boudoir has its own special cachet. Decorated in gold braid with ball-fringe trim or floral sprays, its velvet upholstery is in gold, emerald green, shocking pink, royal blue, blazing red, moss green or petal pink. 20" high. \$19.95 ppd. Barbara Baxter Gifts, HG10, 1727 Highland Oaks Dr., Arcadia, CA 91006.



OF FRONTIER FAME

For comings and goings indoors and outdoors, hand-laced moccasins and pouch bag accommodate with total comfort and now style. Of suede leather in beige, brown, piñon (gray-tan). Boots, women, \$8.50; bag, \$8.75; men's, \$9.95 (send shoe size) plus 95c post. Free catalogue. Desert House, Dept. HG-4, Box 11114, Albuquerque, NM 87112.



CARDINAL CHELSEA

Royal Chelsea white bone china cup and saucer hand decorated with scarlet cardinals and trimmed with gleaming gold. A perfect choice for cheering breakfast coffee, afternoon tea or cocoa after a brisk fall walk in the fields. A find for cup collectors! \$5 a set; two sets, \$9.85 ppd. Order from Downs, Dept. 1410, Evanston, IL 60204.



ENLIGHTENING PEN

By daylight, a nifty ballpoint—but whisk it into darkness and it shines! Chrome-plated satin finish pen comes with penlite battery and refill. Dandy for children of all ages. Great for jotting middle-of-the-night brainstormers. \$3.98 plus 20c post. Anthony Enterprises, HG10, 585 Market St., San Francisco, CA 94105.

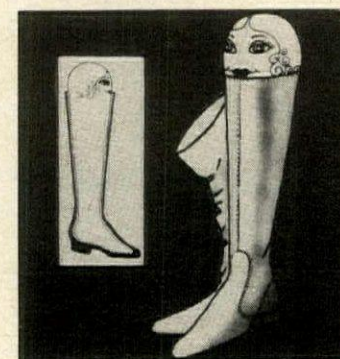

SHAPELY TREE

Inflatable boot trees keep fine leather boots from folding over and cracking. Since boots are forever "in" what with midis, a shapely polished boot is an essential for every wardrobe. Trees inflate to boot size and are great for storage, polishing. \$2.98 a pr.; two pairs, \$5.50. Ppd. The Ferry House, HG10, Briarcliff Manor, NY 10510.

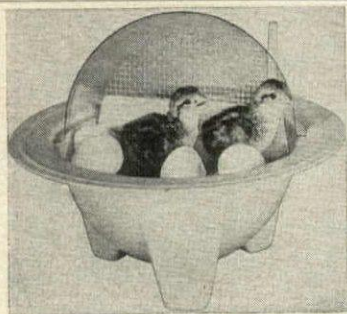

SEE MIRACLE OF BIRTH

\$4.98 POST PAID WITH SIX QUAIL EGGS (\$3.25 Without Eggs)

You get the new clear plastic dome CHICK-BATOR with 6 Bobwhite Quail Eggs (available year-round) and Egg Hatcher's Guide Book. Complete—nothing else to buy. Send check or Money Order today. Send 25¢ for catalogue of larger models for home, classroom and display. Also quail breeding equipment and how to produce and sell quail year-round.

G.O.F. MFG. CO., DEPT. CG
BOX 8152, SAVANNAH, GA. 31402

Newest Idea In Home Decor!

ONLY **\$1.98**

plus .50c postage and handling

Tru-Scent

DECORATOR
FLORAL BOWL

AIR REFRESHER—
ROOM SCENTER

Exciting. Different. Exquisite beauty. Glass jar holds Empress Rose arrangement. Looks real!

Remove lid . . . delicately scented rose aroma refreshes air, helps banish stale odors.

Use in ANY room or office. Wonderful gift. Ideal for patients or shut-ins.



6 DECORATOR
APPROVED COLORS
Pink, Red, Yellow,
Orange, Blue, Peach



Magic
Capsule
is Secret of
long lasting
fragrance.
REFILLS
AVAILABLE.

Dept. 15A

GREAT LAKES TRADING COMPANY
529 S. 6th Ave. / West Bend, Wis. 53095
Wisconsin residents add 4% sales tax.

MAGNADOR®

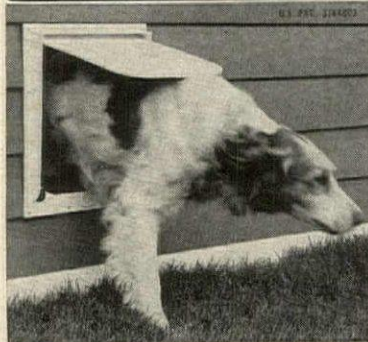

the proven two way pet door

PETS LIKE IT! PETS USE IT!

Best in design—smart appearance—quality built for long service. Automatically closes by Patented Magnetic Device—Nylon locks allow locking from either side—weather tight. Easy installation with furnished kit. 11" x 13" opening accommodates most pet sizes. (13" x 15 1/2" overall size.) Immediate Attention Given to Orders and Inquiries.

plaza enterprises 18.95 POST PAID

P.O. Box 411-H-11, LaCygne, Kansas 66640
ENGLISH "WALLCOTT" CAT DOOR 10.95 PP.



Red & Green Christmas Labels . . . Printed with Your Name & Address!

Quickest, easiest way to return-address your Xmas cards, letters, packages! Gummed, 1 5/8" long red & green labels say "Merry Christmas" or "Season's Greetings". Set of 500 come in handy, snap-closed storage box. Print name, address, zip code. Specify choice of greeting.

42-424 Set/500 Labels, Box.... 1.00

BRECK'S OF BOSTON SINCE 1818

K42 BRECK BLDG., BOSTON, MASS. 02210

12 NEW FOOT DISCOVERIES UNCOVERED BY ANTHONY ENTERPRISES GUARANTEED TO ALLEVIATE YOUR FOOT PROBLEMS



RELIEF FROM BENT TOES

Unique orthopedic pads provide soft, yet effective toe support which help to strengthen and alleviate pain from crooked toes. Even toe tip corns disappear. Elastic yarn slips over toe. Washable. Specify shoe size.

No. F54—Orthopedic Pads \$2.98 Pr.
Mailing 15c

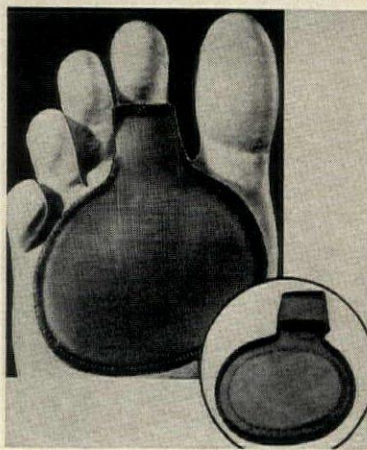

CALLOUS CUSHION

Helps support metatarsal arch, eases tenderness at ball-of-foot. Constructed of two layers of soft foam, covered with nylon type mesh. Slips over toe. Washable. Specify shoe size, left or right.

No. F88—Forefoot Pad \$1.98 Each
Mailing 15c

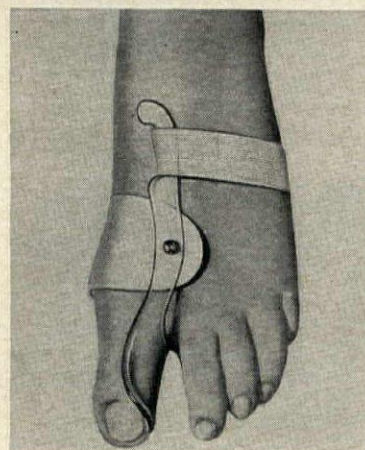

BUNION REGULATOR

Works while you rest or sleep. Lever action urges the bent big toe towards normal position, counteracting the strain which causes discomfort and deformity. Specify shoe size, man or woman, left or right.

No. F35—Bunion Regulator \$6.98 Ea. \$11.98 Pr.
Mailing 30c



RELIEF FROM TIGHT SHOES

Liquid Leather Stretch provides instant relief from tight shoes. Works like a miracle to stretch leather permanently, loosen shoes to conform to your feet while you walk. Harmless and will not stain.

No. 206—Liquid Shoe Stretch \$1.49
Mailing 30c

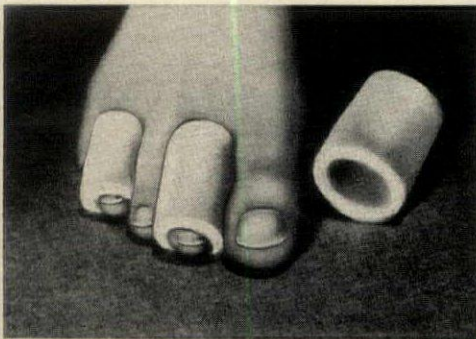

POLYTUBE PADS FOR CORNS

All 'round remedy for the irritating pressures which cause corns. Cushions corns on tops, sides and under toes. Slips onto toe, self-forms to contours, stays in place without adhesives. Thousands of air bubbles soak rubbing, squeezing stress. Non-allergic. Soft, supple, one-piece polyfoam, nylon covered, takes up practically no space in shoe. Wear, wash and re-use. 3 piece Set.

No. F36—Polytube Pads \$1.98
Mailing 20c

LOOP-N-CUSHION TOE REGULATOR

Helps to hold toe in more normal position. The adjustable elastic band provides a downward pull on the 2nd or 3rd toe, helping to hold it straighter. Pressure at callous area of forefoot is eased by the cloth-covered foam pad. Controls toe-against-toe irritation. When walking, elastic retainer bands acts as a corrective manipulator of toe. Washable. One size fits all. Specify left or right.

No. F55—Toe Regulator \$1.98 Each
Mailing 20c

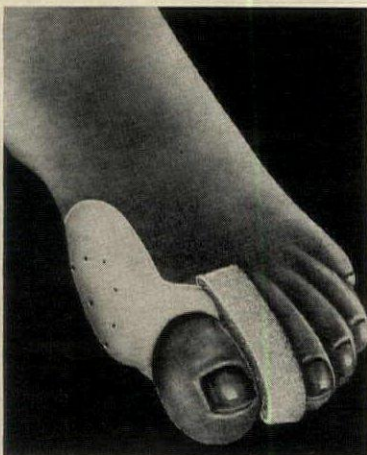
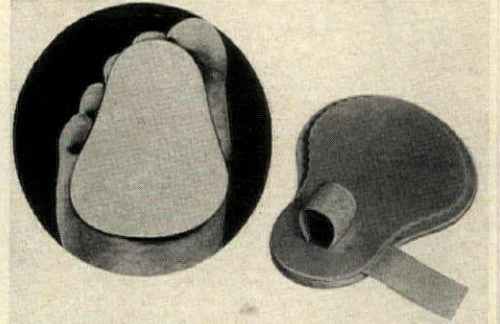

BUNION CUSHION

Protects bunion from shoe friction and pressure. Elastic loop slips over big toe. Soft foam wedge placed between toes hold them straighter. Set of cushion and wedge. Specify shoe size.

No. F47—Bunion Cushion Set \$1.98
Mailing 20c

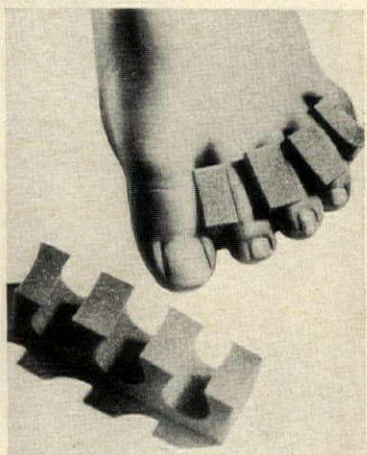

TOE SEPARATORS

Provides gentle, comfortable toe separation. Worn as illustrated or reversed and placed over toes to ease shoe pressure. Also useful for pedicure. Synthetic foam, washable. Specify shoe size.

No. F83—Toe Separators \$1.00 Pair
Mailing 20c

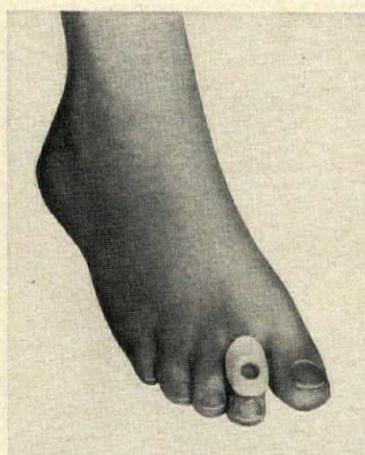

TOE TOP SHIELDS

Sore spots, blisters, corns and callouses caused by shoe pressure get positive relief. Soft foam rubber, open-to-the-air center. Elastic loop slips over toe. Washable. Set of 2 Shields.

No. F82—Toe Top Shields Set \$1.98
Mailing 20c

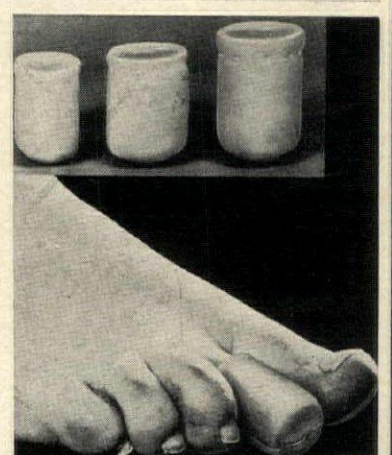

TOE CAPS

Cushions corns on toe tops, toe tips, and between toes. Protects ingrown nails. Foam, nylon covered, non-irritating, washable. Takes up practically no space in shoe. 3 piece set.

No. F34—Toe Caps Set \$2.50
Mailing 15c



CORN AND CALLOUS TRIMMER

Just glide blade, corn or callous "peels" off. Precision made of fine surgical steel. Double edge blade is encased in a protective shell to protect your skin. Easy to clean and replace blade. Uses standard blades.

No. 198—Callous Trimmer \$1.98
Mailing 20c

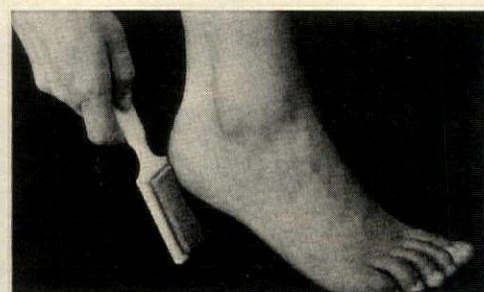

VOLCANIC LAVA STONE BRUSH

Why suffer when you can simply brush away foot pain caused by corns, callouses and rough dead skin. This natural volcanic lava stone does the job gently, safely and painlessly. Keep feet smooth as velvet.

No. 207—Lava Stone Brush \$1.00
Mailing 15c

Anthony Enterprises, 585 Market, Dept. HG-101, San Francisco, Ca. 94105

Name _____

Address _____

City & State _____ Zip _____

Item No.	How Many	Name of Item	Price

NO STAMPS OR COD's, PLEASE Total _____

California residents add 5% Sales Tax _____

SATISFACTION GUARANTEED OR MONEY BACK! Mailing Charges (refer to each item) _____

TOTAL AMOUNT ENCLOSED _____



MUSICAL WALL PLAQUES

Reproductions of famous PAINTINGS hanging in European Galleries. Beautiful multi-colors hand-screened on SILK. Unbreakable GOLD frames. All have Swiss Precision Movement. Size: 7 3/4" \$16.70 each. 55c Catalog showing music boxes from \$10.00 to \$800.00.



Impossible Dream

#33 Pater tune: THREE COINS IN A FOUNTAIN

MUSICAL ALARM CLOCK



#4500 All metal construction Swiss precision one-day Movement four jewels tune: OYE, WHAT A BEAUTIFUL MORNING, SOMEWHERE MY LOVE, or EDELWEISS color: Black or Ivory 3 x 2 x 3 3/4" \$34.70



Man of LA MANCHA revolves as music plays. Multicolors, IMPORT from Italy 18 notes Swiss Precision Movement \$17.60. All music boxes are inspected and oiled before shipped to you Parcel Post INSURED. Add 75c for insured mail.

GRAND PIANO



#11 Made of OLIVEWOOD Has space for small TREASURES tune: LOVE STORY, BLUE, MORE, STRANGERS in the NIGHT, or RAIN-DROPS. 7 3/4 x 5 1/2 x 4 1/2" \$23.00 All BELOVED tunes.

TINY BUBBLES, SOMEWHERE MY LOVE, LOVE IS BLUE, MORE, STRANGERS in the NIGHT, or RAIN-DROPS. 7 3/4 x 5 1/2 x 4 1/2" \$23.00 All BELOVED tunes.

Hildegard & HG, 597 Farmington Ave., Hartford, Conn. 06105

SHOPPING AROUND

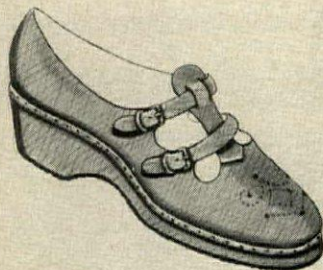

WINTER STROLLER

Beloved sandal with comfortable 1 1/4" wedge heel, zigzag rubber sole. For widths AAAA-EE, 2 1/2 to 12. Grain calf with smooth trim. Beige with otter, bone with malt; navy with light blue; white; black. 2 1/2-10, \$21.95; 10 1/2-12, \$22.95. Add 75c postage. Free catalogue. Solby Bayes, HG10, 45 Winter St., Boston, MA 02108.

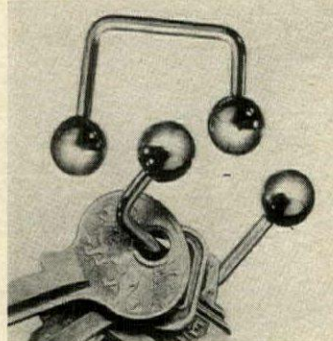

THE KEY HOLDER

We are losers of keys; until we found this little metal job with screw-on balls at either end. The balls keep the keys in their place on the holder and for some happy reason, we have managed to hang on to our keys for months! Silver-plated brass. \$1 ppd. Order from Anthony Enterprises, HG10, 585 Market St., San Francisco, CA 94105.

CHOICE DECOR!

(Finished or Unfinished!)



37" high and handsome! This handcrafted lamp is yours fully finished or sanded satin-smooth ready to decorate. It's perfect to create an accent color—to antique, decoupage or stain a warm wood tone. Beautifully proportioned of native hardwood, this stately lamp is fully wired with a 3-way switch and an 8-ft. cord. Complete with brass harp and finial. Specify Choice of Shades in white or beige Textured Shantung; oyster or brown Burlap. Finished or unfinished, your satisfaction is assured!

\$12.95 each* UNFINISHED

\$20.50* each FINISHED in walnut, colonial maple; or in antiqued barn red, olive, mustard, or wedgewood blue.

*Add \$1.50 postage; West of Rockies add \$2 per lamp.) SEND 10c FOR COLOR BROCHURE of finished & unfinished lamps!

Baxwood Crafters

Dept. HG-10, 1171 Commercial Drive, LEXINGTON, KENTUCKY 40505

PUSH BUTTON COMFORT



BURKE POWERED RECLINER

TOUCH A SWITCH . . . recline to any position, footrest automatically elevates feet and legs as you relax. TOUCH A SWITCH . . . return to sitting position. TOUCH A SWITCH . . . the soft luxurious seat raises gently standing you on your feet.

Write for information on how you can fry the "Powered Recliner" one week without cost or obligation:

BURKE ENTERPRISES

P. O. Box 1011, Dept. HG-10 Mission, Kansas 66202 913-722-0004

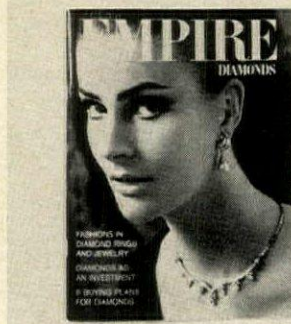

DIAMOND FINDS

New idea in diamond buying—order from Empire's fabulous free color catalogue and save. After purchase have your own appraisal—if not 25 to 50 percent above Empire's price, they'll refund. Ten-day inspections and terms arranged, too. 80-page catalogue free from Empire Diamond Corp., HG10, 350 5th Ave., New York, NY 10001.

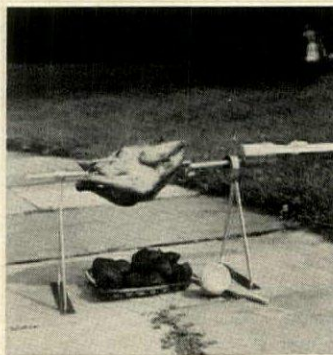

DO IT TO A TURN!

Have rotisserie; will travel! Use it anywhere—land, sea or air. New Cordless Electric Barbecue Spit makes life good and easy. It turns two chickens, small turkey or a 7-lb. roast. Works on two flashlight batteries. \$14.95 plus 95c post. Catalogue 25c. House of Minnel, Dept. HG501, Deerpath Road, Batavia, IL 60510.



PETITE FRANCAISE

Charming modern phone is a petite version of the French model of the '20's that cinema sirens used with such flair. The base is 6" across; phone is 6" high overall in brass with white trim. Just a gentle buzz for the ring. A standard cord and plug. \$49.95 plus \$1.50 post. Free catalogue. Grand Com Inc., HG10, 1152 6th Ave., NY 10036.

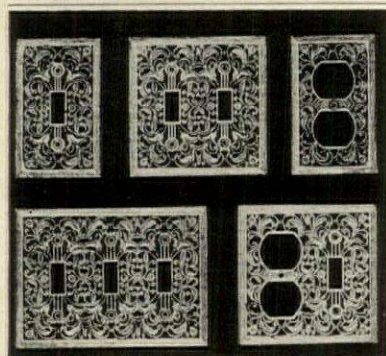

GOLDEN FILIGREE SWITCHPLATES

Add a touch of charm to your home at little cost with our golden switchplates. Brass-plated, antique non-finish finish, screws included. Also available in wrought-iron black.

- SINGLE—3" x 4 1/2".....\$1.00 each 3 for \$2.95
- DOUBLE—4 1/2" x 4 1/2".....\$1.50 each
- TWIN OUTLET—3" x 4 1/2".....\$1.00 each 3 for \$2.95
- TRIPLE—6 1/4" x 4 1/2".....\$2.95 each
- COMBINATION—4 1/2" x 4 1/2".....\$1.50 each
- QUADRUPLE—8" x 4 1/2".....\$3.95 each

PLUS 45c POSTAGE & HANDLING

Pa. Res. Add 6% Sales Tax. Sorry No COD's.

THE ADDED TOUCH

12-H Water St., Bryn Mawr, Pa. 19010



DANISH STYLE

FULL SIZE LOUNGE CHAIR

European imported solid hardwood frame, walnut finish, with authentic gracious curved Danish arm. 28 1/2" wide, 29" high. Thick 4" polyurethane foam seat cushion, 22" x 22"; 3" thick back cushion 17" x 22". At one price, your choice of expandable supported vinyl, or heavy tweed fabric. Colors—Olive, Tangerine, Black, Blue or Tan. Or furnish two yards, 54" wide, your fabric. Cushions zippered, fully wetted and reversible.

Send 50c for sample swatches and complete Danish living room catalog. Shipped unassembled, easily set up in 10 minutes.

ONLY

No C.O.D.'s Shipping charges collect. Send check or money order. \$24.95

GENADA IMPORTS

Dept. J10, P.O. Box 204, Teaneck, N.J. 07666 N.J. Residents add 5% tax



DOWN COMFORTS Beautifully RE-COVERED

... in exquisite down-proof satins, taffetas.

Wool comforts recovered, too. And OLD FEATHERBEDS converted into cloud-soft, feather-fluff, heirloom comforts by ALDEN secret process. ABSOLUTE SATISFACTION GUARANTEED.

Mail Order Only. No salesman will call!

ALDEN COMFORT MILLS-HG • Box 6070 • Dallas, Texas

Write for FREE samples of coverings, testimonials, and descriptive folder today. No obligation.

SHOPPING AROUND

WITCH WIZARDRY

Merry madwoman for the Halloween scene. Big black and orange papier mâché witch is a Mexican piñata. Perfect for the party scene to hang high by the sturdy metal loop. A big two feet over all and just in time for trick or treat tots! \$5. Add 75c post. Merri Makers, HG10, 502 So. Broad St., Thomasville, GA 31792.



FROM ANOTHER ERA

"Blue Onion" design ceramic candle holders hark back to the dark, drafty hallways of Colonial days. Nowadays they serve as most charming assets brightening your fireplace mantel, buffet or dining table. 5" high. Matched pair, \$2.98 plus 25c post. Colonial Studios, Dept. BOE-30, 20 Bank St., White Plains, NY 10630.

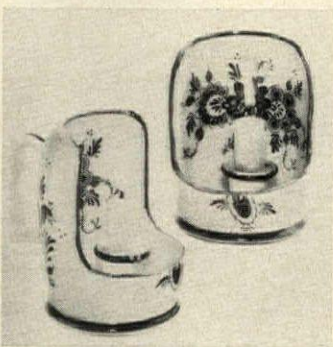

AWARD AT WILL

Framed Award of Merit is on parchment paper 13" by 10". Space is provided for hand lettering name, type of event for which it is given, date and organization. Printing is black and red; wooden frame is black. \$1.98 plus 25c post. Play it straight; ham it up! Anthony Enterprises, HG10, 585 Market St., San Francisco, CA 94105.



BERTH OF BEAUTY

Credit goes to hand-embroidered crewel for spreading its talent for good taste in choice of multi-color, black, gold, natural or avocado on natural backgrounds. Single bedspread, 80" by 115", \$50; full size, 94" by 115", \$60; king size, 120" by 120", \$80. Ppd. Gurian Fabrics Inc., HG10, 11 E. 33 St., New York, NY 10016.

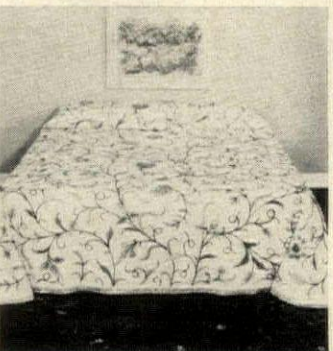

A GIMME FOR SURE

Sheer one-upsmanship for weekend golfers, or any golfers for that matter, is having the ball always land in the cup on a first putt. If his putting is anything but foolproof, solve the problem with a gift that's foolproof—a cup that has the ball right in the middle. \$1.98 plus 25c post. Anthony Enterprises, HG10, 585 Market St., San Francisco, CA 94105.

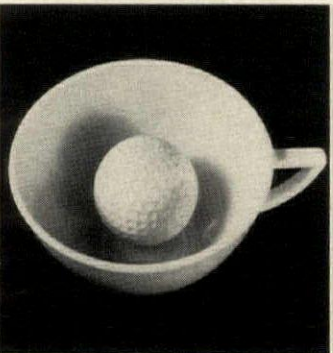

Historic Riverboats—Authentic drawings



are included in an elegant hard-bound art anthology in rich, full color. Owners of this collection may order full-size reproductions from it with a 20% discount. \$20.00.

Specify which of these 20" x 16" charcoal reproductions of famous riverboats you want: Delta Queen / Island Queen / Trimble/Betsy Ann/ Joe Fowler/ Louisville / Washington, \$5

each / 2 for \$9 / 3 for \$12.50 / 4 for \$15.50 / Full set, \$21. Art Anthology Reproduction of over 1,500 works of art from small decoupage prints to large murals

Art Publishers
20 E. Fourth St.
Cincinnati, Ohio 45202

1000 CHARMS IN THIS FREE Charm & Treasure CATALOG

14K SOLID GOLD and STERLING SILVER CHARMS At Direct-To-You-Prices

To have and to hold "those precious moments" are now at hand, brought to mind by cherished charms and miniatures that tell a story all your own.



BIBLE—covers open wide, reveal the Lord's Prayer. 14K Solid Gold \$9.95, Sterling Silver \$2.50



BABY SHOES—A cherished keepsake of baby's first shoes. 14K Solid Gold \$8.50, Sterling Silver \$1.95



UNITED NATIONS FLAGS—Choice of any country in the United Nations. 14K Solid Gold \$8.95, Sterling Silver \$1.95



KNITTING NEEDLES—Everybody loves to knit. 14K Solid Gold \$17.95, Sterling Silver \$3.95



MINK—Every woman should have one. Be sure to order yours today. 14K Solid Gold \$15.95, Sterling Silver \$2.95



WORRY BIRD—Let Worry Bird take your cares away. 14K Solid Gold \$23.95, Sterling Silver \$2.95



HOLLY SPRIG—Enamelled in color for the festive season. 14K Solid Gold \$10.95, Sterling Silver \$2.95



CHRISTMAS TREE—Tips of branches red and green enamelled. 14K Solid Gold \$12.95, Sterling Silver \$3.75



VIRGIN MARY & CHILD—a gracious and colorful reproduction. 14K Solid Gold \$14.95, Sterling Silver \$3.95



CHILDREN OF THE WEEK

CHARMS IN RHYME

Exquisite raised designs. First name and date engraved free on back. 3/4" \$8.50 ea., 1" \$11.95 ea., Sterling Silver \$4.20 ea., 3/4" \$2.20 ea., 1" \$ 2.95 ea.



Fireplace—Colored enamel hangs on this Fireplace, opens and says Merry Christmas. Sterling \$4.00; 14K Gold \$16.00.



CHOICE OF ANY COUNTRY IN U.S. 14K Solid Gold \$12.50, Sterling Silver \$2.00.



TELEPHONE—like a real one but dials "I love you." 14K Solid Gold \$11.95, Sterling Silver \$3.95.



SIAMESE CAT—A must for all feline lovers. 14K Solid Gold \$9.95, Sterling Silver \$2.50.



"LUCKY" THE LEPRECHAUN 14K \$16.95 Sterling \$2.95



THE GOOD ANGEL—watch over you and your loved ones. 14K Solid Gold \$10.95, Sterling Silver \$1.80.



MIZPAH COIN—"The Lord watch between me and thee while we are absent one from another." Halves unattached to fit each other. Sterling Silver: 1" \$1.65; 1 1/2" \$2.75; 1 3/4" \$3.50. 14K Solid Gold: \$17.95, \$25.75, \$35.00.



PLAY A CHARMING CUPID. 14K Solid Gold \$12.95, Sterling Silver \$2.95.



IN ANY LANGUAGE—IT'S LOVE!—Charm her with I Love You in any of our languages—Specify English, German, Italian, French. 14K Gold 3/4" \$8.95, 1" \$12.95, Sterling 3/4" \$2.45, 1" \$3.45. Saying on back 10c a letter.



GRANT ME THE GRACIES TO ACCEPT THE THINGS I CAN NOT CHANGE, THE COURAGE TO CHANGE THE THINGS I CAN CHANGE, AND THE WISDOM TO KNOW THE DIFFERENCE. AMEN.



SAY IT IN FRENCH!—I love you more today than yesterday but less than tomorrow." 14K Solid Gold \$11.95, Sterling Silver \$2.95.



ZODIAC CHARM. Send Birth Date. First name engraved free. 3/4" 14K Gold \$9.25; 1" \$13.35, Sterling Silver \$2.40; 1" \$3.40.



ANGEL OR DEVIL—Probably a bit of both! Two first names engraved on back. Sterling: 3/4" \$2.90, 1" \$3.90, 14K 3/4" \$9.35, 1" \$13.35.

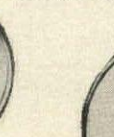

CHURCH WITH VIEW—look inside and see the Lord's Prayer. 14K Solid Gold \$13.95, Sterling Silver \$3.95.



BIRTHDAY CAKE—opens and has candle inside. 14K Solid Gold \$11.95, Sterling Silver \$3.95.



PRAYING HANDS Charm or Pocketpiece. 14K Gold: 1 1/4" \$22.95; 1" \$19.95; 3/4" \$9.95, Sterling Silver; 1 1/4" \$3.95; 1" \$2.95; 3/4" \$2.25.



be-WITCH-ing Only the two of you know what's what. 1 1/2" \$12 in 14K; \$2.50 in sterling; 7/8" \$13.50 in 14K; \$3.00 in sterling; 1 1/8" \$25 in 14K; \$3.50 in sterling.



SPECIAL OFFER! Send only \$1 in cash or stamps and you'll receive the huge, 9x12, 160 page, all inclusive 8500 charm full color catalog. A must for all collectors of charms.

Charm & Treasure INC.

Dept. HG-121, 72 Bowery, New York, New York 10013
I enclose check or money order for the total \$.....
Please enclose 25c in coin or stamps for handling of FREE CATALOG.
NAME.....
ADDRESS.....
WRITE MR. JOHN LAPORTE ABOUT BECOMING OUR REPRESENTATIVE.
Engraving on any charm—10c per letter or number. Please print inscription clearly. Enclose with order.

SPECIAL PURCHASE BRASS TRAY TABLE

\$19.98 ADD \$1.50 POST.

Our own import from India! Unique occasional table is hand carved of shesham wood in a magnificent flower & leaf design. Solid brass tray top is removable for serving, has scalloped edge and is intricately hand engraved. Table folds flat for compact storage. 15 1/2" X 15 1/2".



MONEY BACK IF NOT DELIGHTED

Harriet Carter Dept. 6200 Plymouth Meeting, Pa. 19462

SHOPPING AROUND

FACES

Watch you'll enjoy looking at morning, noon and night. Anthony puts the picture (man, woman or child of your choice) on the face of the Swiss made time-piece. Send black and white or color photo: returned unharmed. Black or blue leather strap. \$15.98 plus 20c post. Anthony Enterprises, HG10, 585 Market St., San Francisco, CA 94105.



LIMOGES MINIATURES

The tiniest porcelain miniatures right from Limoges, France to your shelf. Each delicate piece is flowered and gold-trimmed. Teacup and 3/4" saucer, \$3.98; 1 1/2" pitcher in 2 5/8" basin, \$4.98; 1" flower basket with arched handle, \$2.98; candlestick, \$1.98. Ppd. Miles Kimball, 100 Bond St., Oshkosh, WI 54901.



TRIM YOURSELF

Row, row, row your extra inches away with pumping made easy on a sturdy steel exercise seat. Rowing machine with rugged spring lets you do sit-ups. Helps trim and tone in minutes a day. Compact for easy storage under bed. Order ExerSlider for only \$9.98 ppd. Walter Drake, HG61 Drake Bldg., Colorado Springs, CO 80901.



18TH CENTURY BEAUTY

We are partial to Queen Anne and the furniture that bears her name. Graceful mahogany desk has a finished back so you place it *anywhere*. Handsome from every angle! Key of center drawer acts as a pull. 38" w., 20" d., 29" h. Brass hardware. \$142.50. Exp. coll. Catalogue, 50c. Ephraim Marsh, Dept. 921, Box 266, Concord, NC 28025.

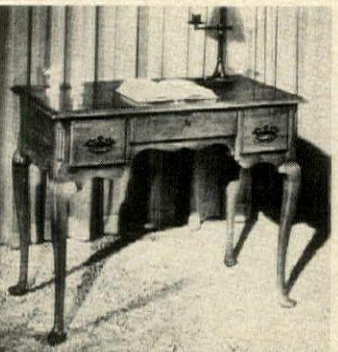

BACKACHE FIGHTER

The bed board is one way to combat back ailments and assure a good night's sleep. Firms an overly soft or sagging mattress. Folding bed board is 5' long, 1/2" thick, folds into four 15" sections. Cot size or one side of double, \$5.95; twin, \$7.49; two sections for double bed, \$10.95 ppd. Better Sleep, HG10, New Providence, NJ 07974.



LACY LOVELINESS

Alençon lace tablecloth in a flowery design on white nylon and acetate. Oblong or oval, 52" by 70", \$15; 70" by 90", \$25; 70" by 108", \$30; 70" by 126", \$35; 70" by 144", \$40. Round, 70" dia., \$22.50; buffet scarf, \$8. 19" sq. napkins, white or ecru, \$1 each. Ppd. Hagen's Specialties, HG101, Box 666, Englewood, NJ 07631.

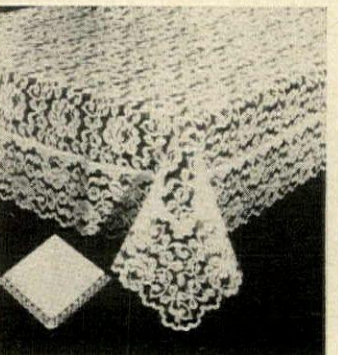

Delft Birth Plate

WILL BE CHERISHED for a LIFETIME

The perfect commemoration for a new born child or a birthday—will arrive in less than 3 weeks by air, direct from Royal Delft factories in Holland. Give FULL NAME, TIME OF BIRTH (designated by clock hands), A.M. or P.M., WEIGHT (designated on child stork is carrying), DATE OF BIRTH and PLACE OF BIRTH. Be sure to include all information for this handpainted plate.

\$14.95

PPD.

Pa. Res. Add 6% Tax • Sorry No COD's
Send 10c for catalog

POSTAMATIC COMPANY

Dept. HG1071, Lafayette Hill, Pa. 19444

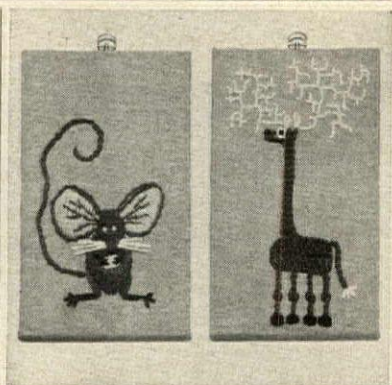

CREWEL BEASTIES

Embroider one of these enchanting creatures in less than three hours. Enlivens any room. Each kit is complete and includes design stamped on colorful Belgian linen, tapestry wool in vibrant colors, English embroidery needle, wood mounting plaque, brass hanging ring, stitch diagram, and easy-to-follow instructions. Size: 10" x 6".

Mouse on Green (shown)	\$2.50
Moose on Turquoise (shown)	\$2.50
Turtle on Yellow	\$2.50
Bee on Orange	\$2.50
Porcupine on Red	\$2.50
Fox on Gold	\$2.50

PLUS 45c POSTAGE & HANDLING

Pa. Res. Add 6% Sales Tax. Sorry No COD's

VICTORIA GIFTS

12-H Water St., Bryn Mawr, Pa. 19010



"MY GUY"

(German Shepherd)

Portrait Sculpture
in walnut wood, painted.

Example of Dog Portrait Sculptures done from life. All breeds or mixed breeds in any size, pose. Exact prices submitted after seeing photos. Also, portrait sculptures of horses or other pets.

32 page catalog of animal subjects in walnut and bronze. \$1.00

M. E. BRASHER Dept. DG
(25th Year)

Chickadee Valley, Kent, Connecticut 06757

The Talbots



Simply Dreamy. Our beloved ankle-length cotton flannel nightie made by Lanz has pretty eyelet ruffles at neck, yoke and cuffs. Enchanting blue/red/green print on white. Sizes XS,S,M,L. \$11.00. Add 90¢ for postage.

Send for free catalog

TALBOTS • DEPT. SD, HINGHAM, MASS. 02043
Branches: Duxbury, Lenox, Mass.,
Mt. Carmel, Avon, Conn.

Harry and David's Fruit-of-the-Month Club®

WE GUARANTEE YOUR SATISFACTION IN EVERY RESPECT...OR YOUR MONEY BACK!

Month after month, a parade of handsome gift boxes, each with your greetings and all announced by a Certificate of Membership inscribed as you direct. These famous Clubs keep you in warm, friendly contact with people important to you or your business. The proved perfect family gift for over 30 years. Sent direct from the orchard... the savings are yours! Ideal for business associates, friends, kinfolk and you!

3-BOX CLUB: Surprise them with gorgeous gift boxes for Christmas, January and February!

Gift No. 111, only... **\$17⁹⁵** delv'd

5-BOX CLUB: Keeps coming and coming! Christmas, January, February, May and September.

Gift No. 141, only... **\$28⁹⁵** delv'd

8-BOX CLUB: Delight them to pieces again and again! Christmas, January, February, May, August, September, October and November.

Gift No. 151, only... **\$45⁹⁵** delv'd

12-BOX CLUB: Flabbergasting! A gorgeous gift every single month of the year.

Gift No. 201, only... **\$69⁹⁵** delv'd

<p><i>Christmas</i></p>  <p>ROYAL RIVIERA PEARS America's rarest and finest fruit. So big and juicy you eat 'em with a spoon. Net weight 6 1/4 lbs.</p>	<p><i>January</i></p>  <p>CRISP MOUNTAIN APPLES Huge, red rascals. Really fresh and snappy from the cold mountain country. Net weight 7 1/4 lbs.</p>	<p><i>February</i></p>  <p>ROYAL GRAPEFRUIT Bigger'n grade A ostrich eggs. Juicy as Oregon rain-clouds. Net weight 10 lbs.</p>	<p><i>March</i></p>  <p>ROYAL ORANGES Rare sunshiney surprises from the pirate coast. Sweet and tempting. Net weight 6 1/2 lbs.</p>
<p><i>April</i></p>  <p>HAWAIIAN PINEAPPLES Two hupaloozers. Fully-ripened the way mainlanders hardly ever taste 'em. Net weight 9 lbs.</p>	<p><i>May</i></p>  <p>WILD 'N RARE® PRESERVES Old-fashioned pure fruit preserves - no preservatives added. Four 3/4 lb. jars. Net weight 2 3/4 lbs.</p>	<p><i>June</i></p>  <p>HOME-CANNED FRUIT Uncanny! Orchard fresh, in extra-heavy syrup. Baked Pears, Summer Delight Pears and Oregold Peaches. No. 2 1/2 cans. Net wt. 5 1/2 lbs.</p>	<p><i>July</i></p>  <p>GIANT KIWI-BERRIES Amazing NEW fruit from New Zealand. Sorta watermelon strawberry flavor. Net weight 2 1/2 lbs.</p>
<p><i>August</i></p>  <p>EXOTIC NECTARINES Plum peachy. Big and blushing. A sure-fire summer sensation. Net weight 5 1/2 lbs.</p>	<p><i>September</i></p>  <p>OREGOLD® PEACHES Family and friends'll never forget these huge Oregon beauties. Net weight 7 lbs.</p>	<p><i>October</i></p>  <p>ALPHONSE LAVALLE GRAPES Big, velvety-black Belgian hothouse type. Used to grow only for Royalty. Net weight 4 1/2 lbs.</p>	<p><i>November</i></p>  <p>SPANISH MELONS From Valencia in sunny Spain. Exotic and juicy with the limes we include. Net weight 6 1/4 lbs.</p>

Harry and David's

ROYAL RIVIERA® PEARS

America's rarest and finest fruit

So big and juicy you eat 'em with a spoon! No fooling! Royal Rivieras are the rarest and finest of over 800 known varieties - so rare in fact, that not 1 person in 1000 has ever tasted them. Beautifully gift packed - sent with your personal greetings - **perfect arrival guaranteed**. And here's the best news - even though they look like a million, and taste even better - they're not high-priced - they're inexpensive!

Gift No. 1 (shown) Net weight 6 1/4 lbs. **\$6⁹⁵** delv'd

Gift No. 2 (a third more fruit for only \$1.50 extra) **\$8⁴⁵** delv'd

Gift No. 3 (family size box of smaller pears) Net wt. 9 lbs. **\$7⁹⁵** delv'd

EASY TO ORDER: Just send us your list. Enclose check or money order (no COD's please). Tell us how to sign your greetings for each gift. All prices include delivery.

Send your orders to:

Harry and David®
BOX L190 MEDFORD, OREGON 97501

©1971, H&D

WANT OUR FREE BOOKLET? IT'S DELICIOUS. See more of our farm-fresh Christmas Gifts and Fruit-of-the-Month Clubs in honest-to-gosh full color. Just send off the coupon right away.

Harry and David BOX L190 MEDFORD, OREGON 97501

PLEASE SEND FREE BOOKLET TO:

Name _____
Street _____ City _____
State _____ Zip _____

(cut out and mail)

**PERFECT
DELIVERY
GUARANTEED**

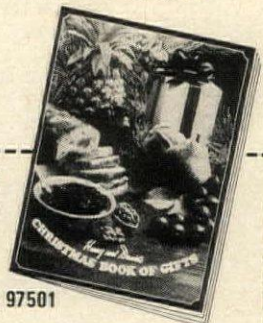

NEW! A TIME IN EDEN

— by Roy Dean

A photo essay on MAN... one of the most beautiful books ever published... the first days of Man.

Against the pristine background of the Caribbean, the author-photographer recreates a living image of the first days of Man. More than 120 pages with 166 photographs (20 in full color) following man through his first experiences and adventures.

"A beautiful tapestry of man's world as it once was..."
"... an evocative and poetic text."

Collectors' edition:
Bound in linen,
hard back, size:
8 1/2" x 11 1/2"
Price: \$15.95,
Tax included.

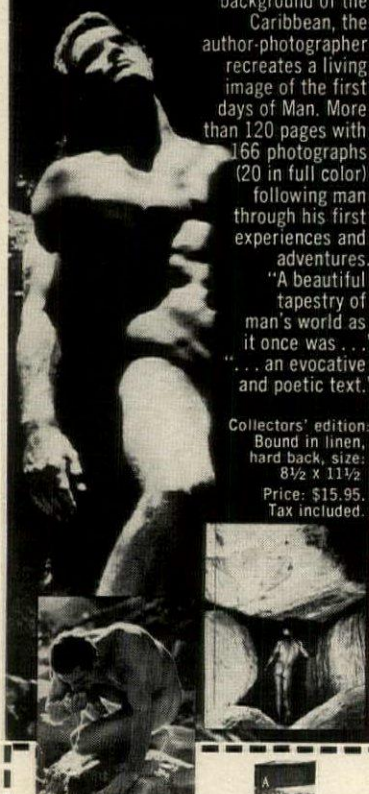

Special Offer - Mail today!

Rho-Delta Press, Dept. HG-110
8939 1/2 Santa Monica Blvd.
Los Angeles, Calif. 90069

Please send me the collectors' edition of "A Time in Eden."
Enclosed is my check money order for \$15.95 (covers postage and handling).

NAME _____

ADDRESS _____

CITY _____ STATE _____ ZIP _____

I would like more information. Please send me illustrated brochure. Enclosed is 25c to cover postage and handling costs.

DOG WASTE GONE with DOGGIE DOOLEY®



DOGGIE DOOLEY keeps grounds clean, insect-free, sanitary. Rustproof heavy plastic doggie septic tank installs in ground; uses safe, non-poisonous enzyme-bacteria action to liquefy pet stools for ground absorption. Shovel up stools, drop into tank, close lid. Enzyme-bacteria action does rest. Harmless to pets, lawns, shrubs. Handles waste of 1 to 3 dogs. 17 1/2" x 11 1/2" with foot-operated lid, shovel, 6 mos. of enzymes incl. \$9.95 plus \$1.00 postage. Extra 12 mos. enzymes \$3.95 plus 60¢ postage.

Manufactured by **HURON PRODUCTS CO.**
Dept. HG-10, 555 Moore Ave., Bellevue, Ohio 44811



REPLACEMENT TOWEL BAR

Now replace a chipped, discolored or broken towel bar in minutes with this new bar that eliminates the need to remove the brackets. Spring loaded end caps make it easy to install and hold firmly in place in standard ceramic or metal brackets. 24" long, made of Polystyrene and can be cut to length. Solid white or crystal clear. **\$2.95** ppd. **NEW 36 inch length bar \$3.95.**

WEST-BERG ENTERPRISES, LTD.
Dept. 210-B, 2842 E. Serendipity Cr.
Colorado Springs, Colorado 80917

SHOPPING AROUND

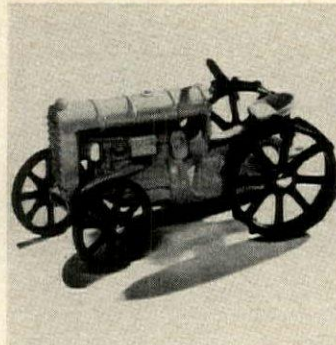

EDDIE ALBERT'S TRACTOR
Here's something for all ages! An exact blueprint copy of the tractor used on T.V.'s *Green Acres*, comes rolling into your home. Fun as a toy, attractive as a curio, useful as bookends. Modeled from Ford's design, it's gray metal with red wheels, 6 1/2" l., 3 1/2" h. \$4.95 plus 80c post. Artisan Galleries, HG10, 2100 No. Haskell, Dallas, TX 75204.

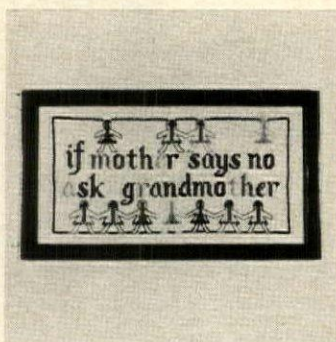

CROSS STITCHERY

Fun Samplers in kit form are ready to stitch and mount in mahogany or maple finish frames. Two designs: grandmother (shown) or gardener, "Old gardeners never die, they just spade away." Oyster linen, 8 1/2" by 15", bright floss, needle, instructions, frame. \$3.50 ea. plus 45c post. Victoria Gifts, 12H Water St., Bryn Mawr, PA 19010.



FATHER'S MUSTACHE

At the turn of the century this colorful type of cup was popular in Bavarian beer halls. Today it's fun and with all the luxurious mustaches and beards, how practical! Decorative on an open shelf, too. Glazed ceramic stein is 4 1/4" h., holds more than 16 oz. Prosit! \$1.98 plus 35c post. Country Gourmet, GO, 545 Fourth Ave., Mt. Vernon, NY 10550.



TELEPHONE TURF

Mr. Bell's tel has a special spot—a little fringed rug from Austria. And it's just the thing since the phone has occasioned many a nick and scratch on the stand. Wool pile in pretty pattern of gold, tan, red and black. 9" by 12". \$4.95; two for \$9.50. Add 35c post. Sleepy Hollow Gifts, HG10, 3023 Crane Dr., Falls Church, VA 22042.



POOL COVERS

All present and prospective owners of a swimming pool would do well to plan now for swimming days. Polypropylene mesh with heavy-duty brass grommets lasts for years. 20' by 28', \$31.50; 20' by 36', \$39.50; 20' by 40', \$44.80; 22' by 40', \$49.50; 24' by 44', \$59.50; 24' by 50', \$67. Ppd. J. A. Cissel Co. Inc., Dept. F, Box 774, Freehold, NJ 07728.

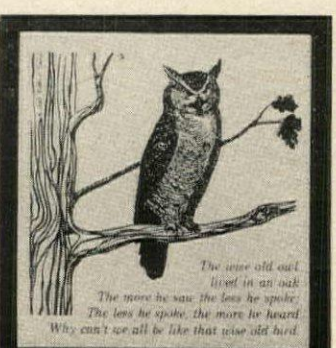

OAK TREE WISDOM

It's a wise gal who puts her hot plates on a ceramic tile backed with cork. The tile is six inches square and has a hanger to use when it isn't protecting precious tables from heat. Owl with a wink sits on an oak tree branch above a printed adage below. \$3.98 plus 40c post. Anthony Enterprises, HG10, 585 Market St., San Francisco, CA 94105.

FURNITURE GUARANTEED TO SAVE FURNITURE

tree house

a floor to ceiling playground for cats. An upper platform serves as a perch. The mid-level house is designed with 5 access holes. Built entirely of wood and upholstered inside and out with rich durable carpeting. Appeals to your cats natural instincts.

\$39.95 Plus Ship.
55 lbs.

Free color brochure on this and other pet items

Pat. Re. 543216

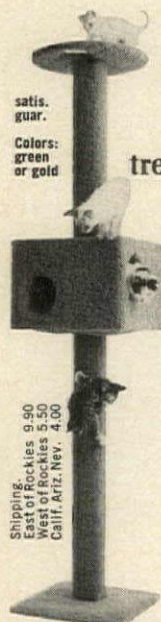

satis. guar.
Colors: green or gold
Shipping: 9.95
East of Rockies 9.95
Calif., Ariz., Nev. 4.00

WEN-RUB PRODUCTS
8921 NATIONAL BLVD.
LOS ANGELES, CALIF. 90034



CUSTOM PRINTED SHIRTS

The latest craze—you think of the slogan and we'll print it! Any slogan for your team... candidate... club... your favorite hobby... or whatever. Up to 30 letters printed on these quality cotton sweatshirts or T shirts. Machine washable, paint will not run or fade. Colors—powder blue, or navy blue. Size S, M, L, XL. Specify size and color. Add \$1.00 extra for printing on both sides. We ship in 48 hours!
Sweatshirt\$4.50 Postpaid
T shirt\$3.25 Postpaid

Holiday Gifts Dept. 310-B
7047 Pecos St., Denver, Colo. 80221

12 HELPFUL TRAVEL AIDS FROM ANTHONY ENTERPRISES WE THINK MORE OF YOU!

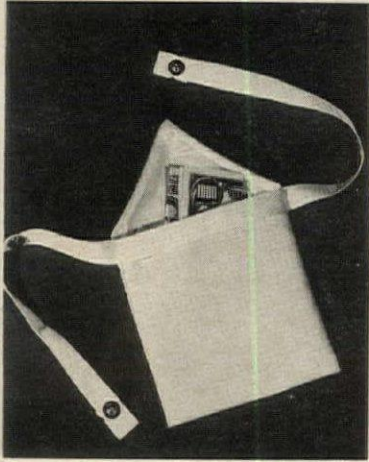

A GAL'S BEST FRIEND

Bosom Money Cache is your best protection against purse snatchers. Snaps onto bra or slip straps. Holds folding money or other valuables. Plastic lined with a fold-over flap. Keeps contents dry. A "must" for every woman.

No. 141—Bosom Money Holder..... \$1.98
Mailing 15c



SLEEP MASK

Ideal for day sleepers and a life saver if you sleep with a reader in bed. Designed to fit men and women. It shuts out light. Flexible foil molds to fit your individual features. Adjustable elastic band.

No. 202—Sleep Mask..... \$1.98
Mailing 15c Each



ENJOY SOUND SLEEP AGAIN

Lock out disturbing noise that robs you of refreshing sleep . . . even snoring! Ear-Drum Silencers designed by a sound engineer. Medically accepted. Soft, pliable, with an easy-to-grasp safety flange.

No. 124—Ear Drum Silencers..... \$1.59
Mailing 15c

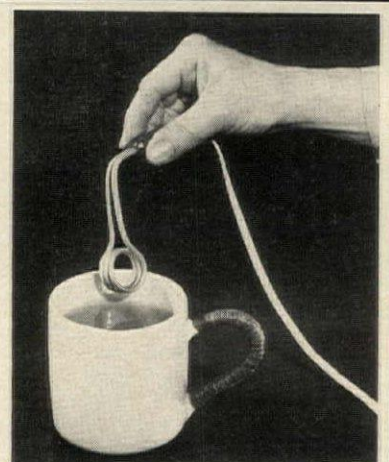

TRAVEL WATER HEATER

The perfect answer when you're yearning for a solo cup of brew. Place this wonderful little gadget in a cup of water, plug in any 110 volt electrical outlet and in just seconds, the water is boiling for instant coffee or soup.

No. 172—Travel Water Heater..... \$1.49
Mailing 15c Each

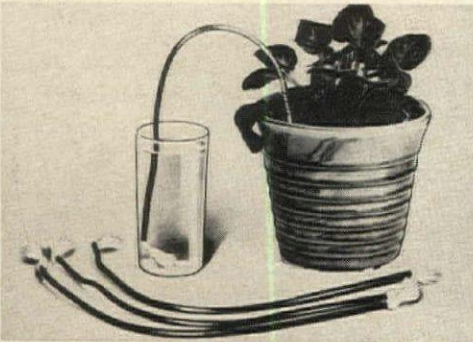

PLANT NURSEMAIDS FOR THIRSTY PLANTS

Planning a trip, but worried about your thirsty plants? Use these wonder wicks to feed moisture to plants for up to 8 weeks. Insert one end of wick in soil, the other in water. Will not rot or mildew. Reusable. Set of 4.

No. 200—Plant Nursemaids... \$1.98
Mailing 20c Each Set

MAKES SWIMMING EASIER

Swimming Aid increases the body's natural buoyancy, making swimming easier for beginners and experts alike. Thin, inflatable, air-tight jersey worn underneath swim suit. For men, women or children. State waist size.

No. 164—Swim Mate..... \$8.98
Mailing 35c Each

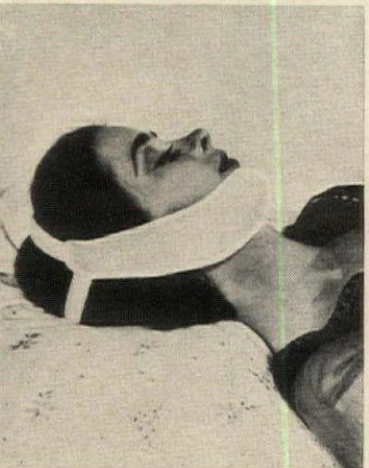
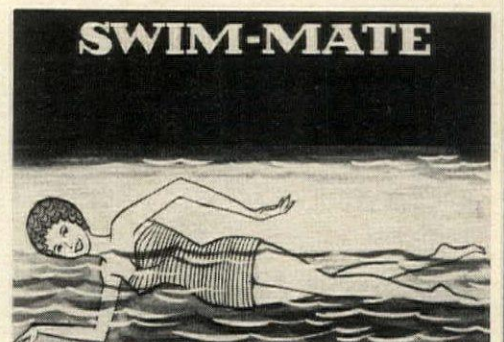

SNORE NO MORE

Scientifically designed anti-snore mask insures sound silent sleep. Washable nylon mask fits over chin, keeps jaws closed, prevents snoring by encouraging proper breathing. Adjustable to fit men and women.

No. 113—Anti-Snore Mask..... \$2.98
Mailing 20c Each

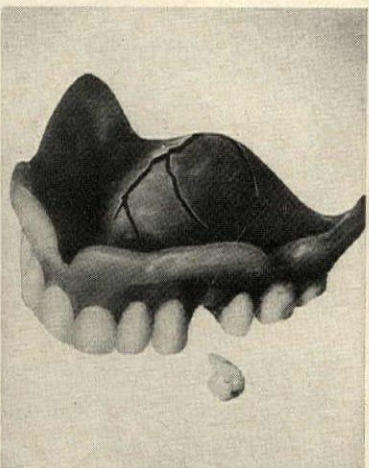

DENTURE REPAIR KIT

Be prepared for an emergency. Denture Repair Kit fixes breaks, cracks or loose teeth in dentures. Avoid embarrassment when traveling. Kit includes material similar to that used by dentists. Instructions included.

No. 121—Denture Repair Kit..... \$1.98
Mailing 20c Each



REPAIR EYEGLASSES ANYWHERE

This handy kit is invaluable whenever glasses come apart at home, at the office or when traveling. Carry it in your pocket. Kit includes a professional optical screwdriver and an assortment of frame screws.

No. 148—Eyeglass Repair Kit..... \$1.29
Mailing 15c

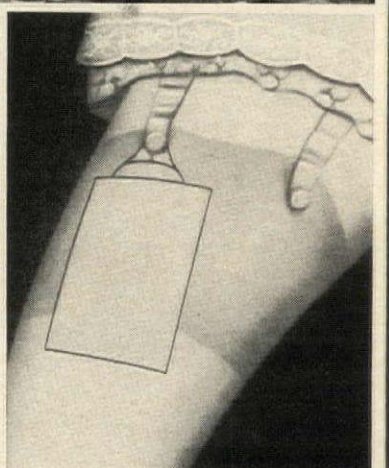

STOCKING WALLET

The Stocking Wallet is the perfect travel companion. Keeps bills secure between thigh and stocking top. Insert money in the hose hideaway, fasten to garter button and the cash is safe as can be. Washable.

No. 168—Stocking Wallet..... \$1.98
Mailing 15c



PROTECT EYES FROM GLARE

Enjoy comfortable vision in strong sunlight, while playing tennis, golfing, motoring or walking. Adjustable dark green plastic shield slips on your specs in a jiffy. Gives added protection to sun glasses.

No. 184—Sport Visor..... \$1.98
Mailing 15c Each



ZIPPER MONEY BELT

Genuine top grain calfskin leather belt with a long zipper compartment making it easy to conceal 15-20 large bills undetectably. Belt is 1 1/4" wide with nylon coil zipper. Sizes 30 to 44. Black or Brown. Specify color and size.

No. 133—Leather Money Belt..... \$8.98
Mailing 35c Each

Anthony Enterprises, 585 Market, Dept. HG-101, San Francisco, Ca. 94105

Name _____

Address _____

City & State _____ Zip _____

Item No.	How Many	Name of Item	Price

NO STAMPS OR COD's, PLEASE Total _____

California residents add 5% Sales Tax _____

SATISFACTION GUARANTEED OR MONEY BACK! Mailing Charges (refer to each item) _____

TOTAL AMOUNT ENCLOSED _____

The SURF is the Sound for
A Peaceful Background

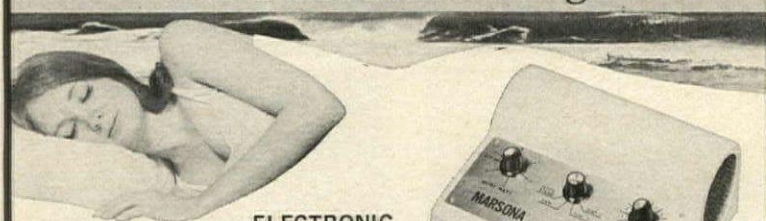

ELECTRONIC
MARSONA[®]
puts you there.



SEA
OR RAIN
AT YOUR FINGERTIPS

The peaceful sound of the sea...
the gentle soothing sound of waves breaking
upon a tranquil shore... or a warm rain;
these sounds are at your fingertips, night and day,
masking out unwanted noise. MARSONA puts
you there. In burnished white or antique black.
Refund Guaranteed PPD. \$75.00

No C.O.D.'s please N.C.
residents add 4% Sales Tax.



BRUNSWICK HOUSE

Dept. HG10, P. O. Box 296, Castle Hayne, N.C. 28429

SHOPPING AROUND

DREAMS AHOY

If a waterbed's too far out, but you want that too feeling, how about a water pillow? Exotic pleasures await you when hot or cold tap water fills the heavy-duty vinyl. One side's flowered, the other blue. 15" by 22½". A sensation for beach or bedroom. And it won't leak! \$3.50 ppd. West-Berg, HG10, Box 4177, Colorado Springs, CO 80909.

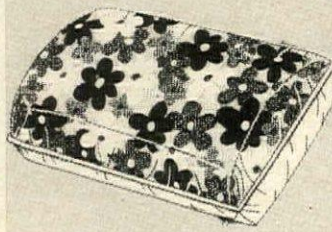

SUR-PRIZE HIM

If you're into a sport, you expect to get ribbed. But even the best golfers have a day of missed putts. Be prepared to move in with the top award anyway. "Greatest Golfer" ribbon 9½". Boss, bowler lover, Dad, Mother. \$1.98 plus 20c post. Anthony Enterprises, HG10, 585 Market St., San Francisco, CA 94105.



HAWAIIAN LUAU

"Geev'um" a Hawaiian treat at your next party. Geev'um, in red, on the glasses is a Hawaiian pidgin expression freely translated to mean "Pour it on and get with it". A recipe book for tropical drinks and four 15 oz. glasses, \$9.95; four glasses, only \$8. Ppd. House of Aloha, HG10, P.O. Box 355, Lahaina, Maui, HI 96761.

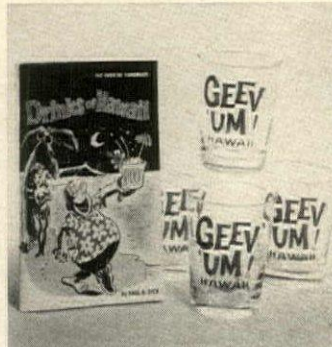

BE GONE!

Want to be alone? Assert your order with a woven straw door mat that states your desire in no uncertain terms. Mat is 21" by 15". It gives its message in letters bold and clear. Salesmen might take heed. Friends know it's a joke. \$2.98 plus 35c post. Anthony Enterprises, HG10, 585 Market St., San Francisco, CA 94105.



TAKE A FLYER

If he knows aviation (or just reads "Peanuts") he knows and loves Snoopy, famous World War I "flying ace". Black and white with a red helmet, he's in his familiar attack position on tie tac or cuff links. 14k gold-plated finish, 1" long. Tie tac \$3, cuff links \$4. Add 25c post. Holiday Gifts, Inc., 310-D, 7047 Pecos Street, Denver, CO 80221.

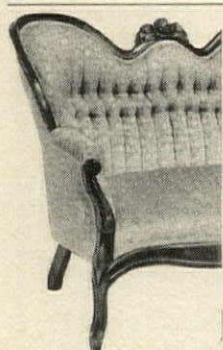
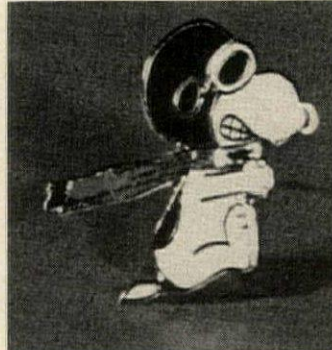

14" Marble-top table
in solid mahogany
\$19.95



Hand-Carved Love Seat \$199.95

Romantic Victorian

solid mahogany, hand-carved furniture!

New way to save on finest quality furniture. Shipped direct from factory to your home (plus small freight). All tables have marble tops from Italy. Large choice of sofas, chairs, lamps, bedroom, dining room. Superb workmanship at modest prices. America's largest selection here. And, costly fabric cuttings are sent free!

Magnolia Hall, 726 Andover/Atlanta, Ga. 30327

To get big catalog G-101 and costly fabric cuttings, send just \$1. We will refund with certificate good for \$2 on your first purchase.

Name.....

Address.....

.....Zip.....

Magnolia Hall, 726 Andover/Atlanta, Ga. 30327

Early American Lantern \$35 Town Crier Lantern \$35

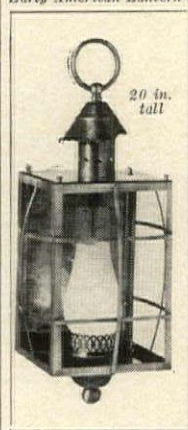

20 in.
tall

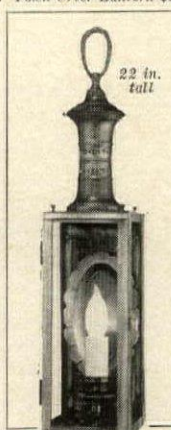

22 in.
tall

Hand-crafted from solid brass or copper

**RARE, ANTIQUE
LAMP REPRODUCTIONS**

We build these lamps entirely by hand, in the old-fashioned way. The designs are authentic copies of lamps that lighted streets and houses 200 years ago (except, of course, they are electrified). Available as wall fixtures (shown above) or table lamps (\$4 more). Our little factory can't make too many of these; order early. Send \$1.00 for beautiful full-color lighting catalog. We'll refund with \$2 off on first order.

THE LAMP CRAFTERS (Dept. G-101)
Box 501, Lawrenceville, Ga. 30245

DOLLY DOLL HOUSES

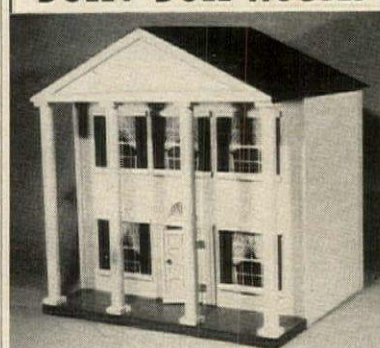

Hand crafted, fully assembled, sturdy all wood and hardwood construction with luan mahogany floors. Lifelike, authentically scaled 1" to foot. 10 models to choose from. 2 houses fully lighted. Some have up to six rooms, individually wallpapered and red carpeted staircase. Prices range from \$20.00 to \$55.00. Shipped F.O.B. factory. For complete color brochure, send 25c to:

DOLLY DOLL HOUSES

BOX 65 GLENVILLE STATION
GREENWICH, CONN. 06830

(colonial style house as shown, \$55.00)

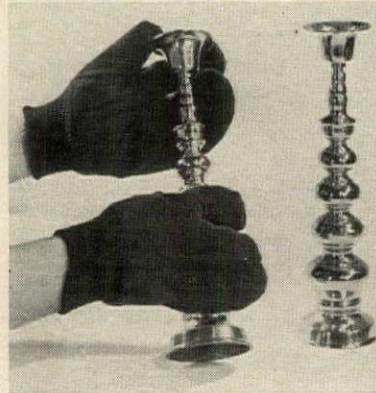

Silver Polishing

GLOVES \$2.00 PAIR
Add 25c post. & handling
2 PAIR \$3.98 PPD.

You'll love these gloves with the polish impregnated, with lining to keep hands clean. Designed with free fore-finger and thumb for easy handling, they never need washing as polishing qualities improve with use. Outlasts jars of polish. One size fits all. Takes the dirty work out of keeping your silver shining.

Pa. Res. Add 6% Sales Tax • Sorry, No COD's
SEND FOR FREE GIFT CATALOG

TAYLOR GIFTS Dept. 2, 355 E. Conestoga Rd.
Wayne, Pennsylvania, 19087

SECRET POWER ANTENNA

Power plug attaches to rear of TV set and into any AC/DC outlet to bring marvelously crisp, clear pictures and eliminate all manner of ghosts and electronic gremlins. Unseen antenna eliminates need for ugly roof equipment or old-fashioned rabbit ears. For Black & White or color. UL approved.

Secret Power Antenna
\$3.98 + 30c Mailing Each
Calif. residents add 5% sales tax.
Satisfaction guaranteed.

Anthony Enterprises
585 Market St., Dept. HG-101
San Francisco, Calif. 94105

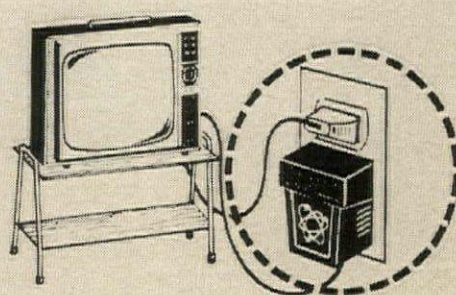

SHOPPING AROUND

TIMELY TOUCH

This is the year for locket, lavaliere and the like for clingy body shirts, sweaters. A pretty version with a day or night life is this copy of antique watch face of turquoise and rhinestones on a golden chain 27" long. Locket is 1 1/2" dia. \$5 ppd. House of Camelot, HG10, 38 Carroll Court, Greenlawn, NY 11740.



FROG FIND

You put a wicker frog on the floor where it fills a people bill (that's what this beguiling creature's all about): big wide mouth's born open for use as wastebasket or provocative shape for dried flowers. Natural with bright marble eyes. 19" h., 16" w., \$18.95. Ppd. Add 50c W. of Miss. Yield House, HG10, North Conway, NH 03860.

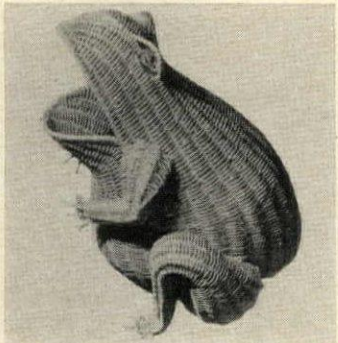

STANDING ORDER

Beautiful rosewood stands, hand-carved in century-old Oriental patterns are superb show-off spots. Decorative to display a treasured figure, a flowering plant. Shown is the low base model at \$2.50 and the footed version at \$6.75. Both are 4" in dia. Ppd. Other sizes. A. C. Gifts, HG10, 2642 Central Ave., Yonkers, NY 10710.



REAL CUT-UP

We flipped for this clipper! If you love snipping recipes, coupons, ads and *Shopping Around*, clipit paper cutter speeds the job. Neater and safer than scissors. Order now for your school children—and one for Pop's office, too. \$1 plus 20c post. from Anthony Enterprises, HG10, 585 Market St., San Francisco, CA 94105.



MINT CONDITION

How to make coin collectors of just about everyone. That's the idea of this great looking 8" plate with hand engravings of 1964 silver coins and a Kennedy half in the center. They're all about twice life size set in see-through crystal and frosted. It's \$15. For lucite plate holder, add \$12. Ppd. Downs, Dept. 1410, Evanston, IL 60204.

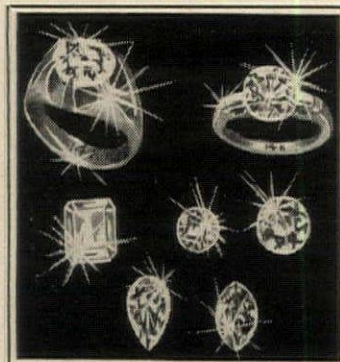

PURE WHITE BRILLIANCE

at \$22 per carat

Luxurious simulated DIAMONDS—man made, incredibly like the real thing in beauty, brilliance, whiteness and hardness, at a fraction of the cost. The VEGA is UNCONDITIONALLY GUARANTEED FOR LIFE not to scratch, break, chip, dim or discolor, or will be replaced at NO COST. Cut and polished on diamond wheel by experts to full 58 facets for maximum brilliance. Cost, not thousands, just \$22 a carat! EASY PAYMENTS. Sold on 10 day MONEY BACK GUARANTEE.

For FREE CATALOG of styles set in 14K white or yellow gold, for men and women, write:

VEGA Co. Dept. HG-10, Box 465, Radio City Sta., New York, N. Y. 10019

Good Ideas by mail from Walter Drake

4020 DRAKE BUILDING, COLORADO SPRINGS, COLORADO 80901



SELF-STICK NO MOISTENING

SELF-STICK GOLD FOIL LABELS

Gleaming gold foil labels stick anywhere — a smart touch to personalize letters, books, cameras, briefcases, records, etc. Classic border, handsome black printing. 1" x 1 3/4". Up to 4 lines, 27 letters and spaces per line.

P4010 250 Gold Foil Labels \$1.98

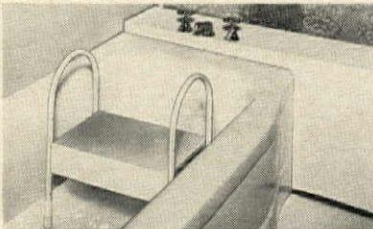

BATHTUB SAFETY SEAT

Bathe in safety and comfort. Ideal for foot baths, sit-down showers, bathing children. Sturdy grips help elderly people get in and out of tub. White enameled metal; non-skid rubber feet. Three position seat. 11" x 16" x 20".

H489 Bathtub Safety Seat \$9.95



DOUBLE-POWER PAGE MAGNIFIER

Magnify a whole page up to 4 times its print size with this new deluxe 4-power page magnifier. Twice as powerful as we have offered previously. Water-thin, so it can be kept in a book. 7" x 10" plastic; imitation leather frame.

S6066 Full-Page Magnifier \$1.50

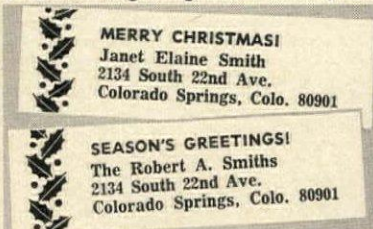

RED & GREEN CHRISTMAS LABELS

Gummed labels for Christmas cards and correspondence! Red and green holly design with choice of "Merry Christmas" or "Season's Greetings" plus 3-line name and address in red. 500 labels in handy box.

X762 Christmas Labels \$1

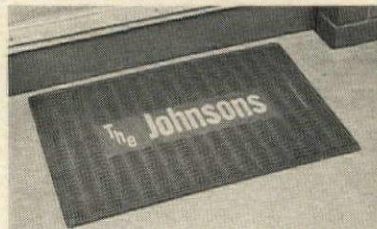

PERSONALIZED VINYL DOOR MAT

For your own home and for gifts! Tough, springy vinyl tips trap sand, grass, dirt. Self-draining. Name is molded in white letters (max. 17) on blue, green, red, brown or black 19" x 30" mat. Specify color. 2-4 weeks delivery.

D7053 Door Mat \$6.98

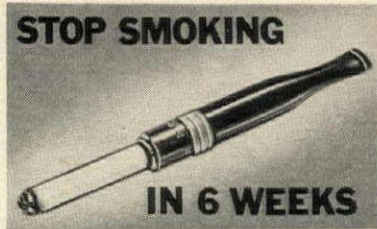

TAPER-OFF CIGARETTE HOLDER

allows you to smoke at your regular rate, but it tapers off the amount of smoke you take in. Just turn the metered ring a notch lower each week, metering out smoke and metering in air. By the end of 6 weeks, you're through smoking!

F1105 Taper-Off Cigarette Holder . . \$2.98



1000 RETURN ADDRESS LABELS \$1

Quick, easy way to put your name and address on letters, records, books. Any name, address & Zip code up to 4 lines beautifully printed in black ink on white gummed labels; rich gold trim. Free handy box.

S716 1000 Labels \$1



EASY COMB FOR PETS

Now you can comb out knots, mats, snarls and burrs from your pet's hair without strain or pain. Leave his coat smooth and neat. Knurled brass safety blades remove snarls, etc. as you comb through coat. A pet owner's must.

F6091 Pet Groomer \$6.95



GIANT 2-FT. x 3-FT. POSTER

Send in any picture, document, marriage license, birth certificate, wedding invitation, black and white or color snapshot (no negatives) . . . or a 35mm color slide . . . and have it enlarged into a giant 2-ft. x 3-ft. black and white poster. Comes rolled in a mailing tube to prevent creasing. Your original returned safe and sound. A real conversation piece for any room or office!

P5009 Giant 2-Ft. x 3-Ft. Photo \$3.98

Walter Drake & Sons
4020 Drake Building
Colorado Springs, Colo. 80901

SATISFACTION GUARANTEED OR MONEY BACK! We ship POSTPAID!

NAME _____
ADDRESS _____
CITY & STATE _____ ZIP _____

ITEM NO.	HOW MANY?	NAME OF ITEM	PRICE

Colorado residents add 3% tax. TOTAL ENCLOSED (or charged) _____

Charge Master Charge acct. #: _____ Print the Bank No. from the lower part of Master Charge card: _____
 BankAmericard acct. #: _____

RELAX! SHOP AT HOME FOR YOUR HOLIDAY GIFTS

... and let us ship them for you with a free gift card expressing your own personal greeting.

3-D CHESS

A modern space age concept brings new dimension to this time honored game with three crystal clear board levels suspended on steel arm. Use set for a unique sculpture. #157: \$11.95 plus \$1.10 post

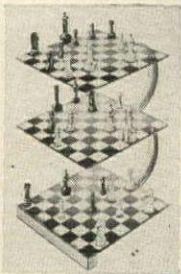

PLATTER CHATTER

Put tangy spreads, snacks and colorful sauces in the wells of this platter and they spell "DIP". Amusing yet practical gift for friends who love to entertain. You'll want some for your own holiday buffets as well. White 20 x 13". Also in "EAT" and "CHOW" for gay informals. \$6.95 each plus \$.95 post/hdlg.



SMART GIFT

Vibrant colors are braided into a 70" sash. Dramatic for long skirts, pants or hostess wear. Comes to you ready to wear or give as a gift. Fine washable acrylic yarn. \$3.95 + 35¢ post.

Gay, practical and mini-priced. Write notes on laminated surface with felt tip pen included. Erase easily with damp tissue. Handy for kitchen or den. White or gold with a quaint Pa. Dutch motif. #448: \$2.50 + 35¢ post/hdlg.



Things to make & finished decorations catalog 25¢

Box 228 G-110, Abington, Pa. 19001

Something satin because she's so special.



Tell her how special with a whisper of a nightgown in elegant, lace-trimmed acetate satin. The bikini pants are satin and stretch lace. Mint, Orange or Pink. Sizes 32-40. \$16.50 ppd. Monogram, \$2.00.

SCINTILLA® SATIN SHOP

4802 N. BROADWAY G-10
CHICAGO, ILL. 60640

"Everything Exotic in Satin"

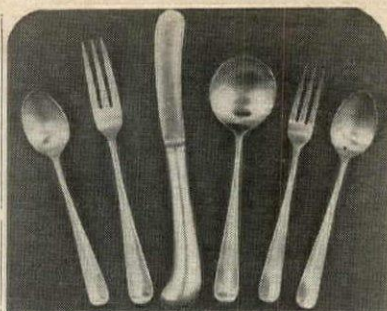

Pistol-Handled Stainless in an heirloom tradition

An exact replica of a famous old sterling pattern, with graceful pistol hollow handled knives, 3 tined forks and rattailed spoons. In heavy hand-forged (these are not stamped) satin finished stainless. Service for eight includes 8 dinner forks, 8 dinner knives, 8 salad forks, 8 soup spoons, 16 teaspoons, plus 2 serving spoons.

50-piece service for 8 \$29.95
75-piece service for 12 44.95
Steak Set, 8-piece pistol handles (not shown).
Gift boxed. \$16.95

OPEN STOCK AVAILABLE
Economy Set, stamped, not forged.
50-piece service for 8 \$19.95
75-piece service for 12 29.75

ALL POSTPAID BY US
SETH and JED

Dept. HG-101, Great Barrington, Mass. 01230

Authentic Reproduction

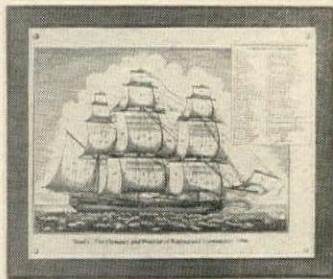

Clipper Ship Engraving

A striking wall hanging for den or office. This finely detailed reproduction of a brass etching mounted on a mahogany finished plaque depicts the sails of a twenty gun ship from the late 1700's. Size 16" x 20". \$15.00. Massachusetts residents add 3% Sales Tax. Add \$1.05 for shipping and handling. Satisfaction guaranteed or money back. Sold by mail only.

Write for free color catalog.

Arborlite

Arborlite, Inc., 57 E. Main St., E. Brookfield, Mass. 01515

LIMITED FIRST EDITION



BERTA HUMMEL COLLECTOR SERIES™

"Angel in a Christmas setting" by Sister Berta Hummel is sought after by both figurine and plate collectors. This 8" porcelain collector's plate is ready for hanging. \$15.00 incl. postage and insurance.

Fine Art Works from \$10 to \$2500
COLLECTOR'S CORNER, INC.
61 MAIN STREET SOUTH
KINGSTON, NEW JERSEY 08528
(609) 924-4204

SHOPPING AROUND



AMERICANA MIRROR

Federal eagle crowns round mirror that is a reproduction of an antique beauty. Frame is antiqued gold and looks like gilded wood. 18" h. by 9½" w. Charming touch for a traditional hallway, dining or living room. Handsome in pairs above a console table or mantle. \$3.98 each plus 85c post. Harriet Carter, Dept. 6301, Plymouth Meeting, PA 19462.



LAMINATED MAPLE

Top butchers know that maple is the best wood for their blocks; here it is in a country dining table. Legs are nicely lathe-turned. 36" by 24", \$88.50; 60" by 30", \$124.50; 72" by 36", \$150.50. Rounded corners slightly extra. Exp. coll. New catalogue, 50c. Butcher Block & More, Dept. 101-D, 1600 So. Clinton, Chicago, IL 60616.



LISTEN, MY CHILDREN

And you shall hear the alarm to tell you the parking meter has run out! Attach it to the key ring, park the car and set it for the meter's time; it will ring loud and clear saving you from the clutches of the meter maid. Key chain comes with it, \$4.98 plus 20c post. Anthony Enterprises, HG10, 585 Market St., San Francisco, CA 94105.

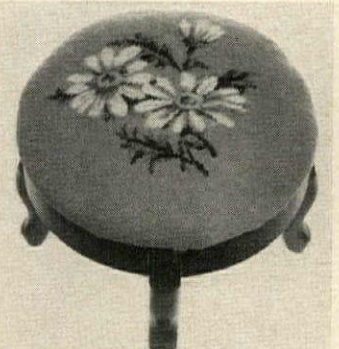

HANDPICKED DAISIES

Daisies do tell! You needlepoint background for pillow or footstool; flowers are handworked for you in white, gold and green. 14" by 14", \$5.95 plus 45c post. Add \$2.95 for antique gold background yarn. Stool, 8" h., 11" dia. in muslin, fruitwood finish sized for canvas \$14.95 plus \$1 post. The Stitchery, HG10, Wellesley Hills, MA 02181.



LOGARHYTHM

Fireplace logs tote easily in a denim carrier with sturdy canvas-weave double handles that run completely around the sling. Navy blue with red, and washable in the machine. About 15¼" by 36", it totes a good pile of logs for crackling fall fires. \$4 ppd. Miles Kimball, 100 Bond St., Oshkosh, WI 54901.



NOBLE WHITE LUCK

Edelweiss is called the noble white flower of the Tyrolean Alps and it is reputed to bring luck to the wearer. From Austria, earrings are silver bells delicately enameled with white edelweiss on blue background. Bells tinkle as you walk. 5/8" l. Specify screw or pierced type. \$8.50 ppd. Shopping International Inc., Dept. 554, Norwich, VT 05055.

The Wigmakers. Wonderful new 100% modacrylic stretch wigs that fit everyone!

The style you see is the style you get... permanently set, permanently styled, crushproof, washable, lightweight, guaranteed, and best of all you save over \$20 on each wig.

They come in stunning natural colors: Black, Off Black, Dark Brown, Medium Brown, Light Brown, Light Auburn, Dark Auburn, Honey Blonde, Champagne Blonde, Ash Blonde, Platinum Blonde, Frosted, Light Frosted, Mixed Gray.

It's up to you—it's your money—But The Wigmaker gives you more than your money's worth or your money back.



ANNETTE
\$10⁹⁸

Hand finished hairline for a more natural look.



ANITA
\$10⁹⁸

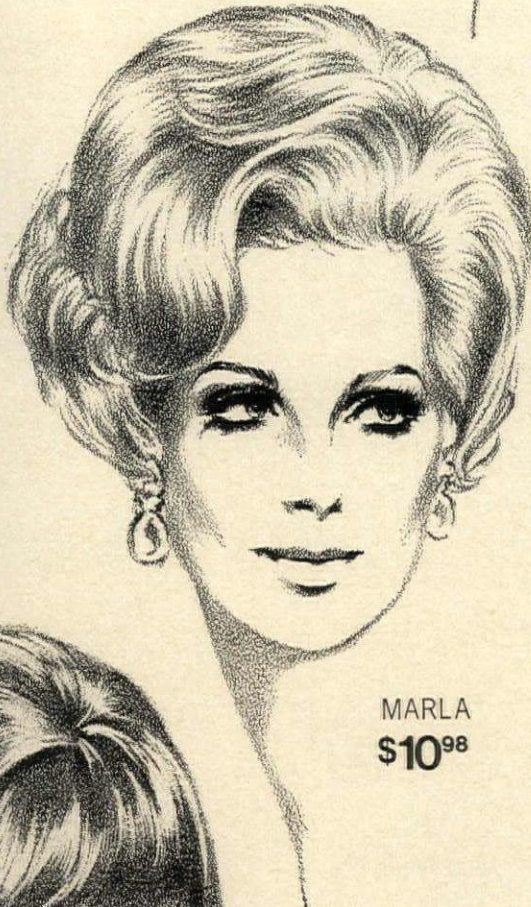

MARLA
\$10⁹⁸



PHAEDRA
\$10⁹⁸

Hand finished hairline for a more natural look.



TINA
\$16⁹⁸

Wigmakers

Dept. HGA-1
Neptune, N.J. 07753

Please send me _____ wigs for \$ _____ plus \$1 shipping and handling charge for each wig. If I am not satisfied I may return the wig in 10 days and get back the money I paid for it.

Wig name _____ color _____

Wig name _____ color _____

I enclose full amount \$ _____

I enclose \$2 Good Will deposit for each wig. I will pay postman balance plus post office and handling charges. N.J. residents add 5% sales tax.

Name _____

Address _____

City _____ State _____ Zip _____

Made by skilled craftsmen in Hong Kong/Taiwan to give you these extraordinary values. Modacrylic fiber made in U.S.A.

LOVE CAKES

and other
old-world delectables



Chanté

LEBKUCHEN, literally "Love Cakes," have been a German tradition for centuries. Decorated and inscribed Lebkuchen were shyly exchanged between lovers. But these delicious honey and spice cakes were also popular for festive gift-giving and enjoying by all lovers of good food. This year, gift yourself—and your favorite friends—with these gourmet delicacies.

12 oz. Lithographed Ass't Tin (shown) \$3.00 ppd.
Large Flowered Tin 6.50 ppd.
Cupid Chest 9.50 ppd.

SPITZKUCHEN and DOMINO STEINE are chocolate-covered traditional German fruit cakes... a nostalgic reminder of a world where the finer things were deeply appreciated.

Spitzkuchen: 1 lb. Lithographed Tin \$3.00 ppd.
Domino Steine: 1 lb. Lithographed Tin 3.00 ppd.

Write for mail order catalog.

By Estee Candy Co., Inc. Dept. HG-101, Palisades Park, N. J.

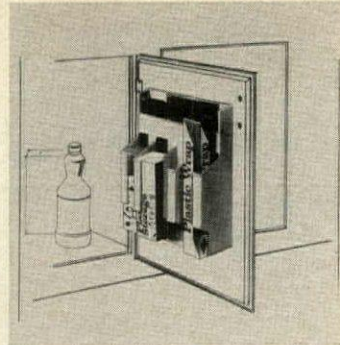

KITCHEN ORGANIZER

Beige high-impact plastic compartmented organizer takes boxed foils, clear plastic wraps, refrigerator bags plus garbage and paper grocery bags. Mount it on closet or inside cupboard door to keep things handy, but out of sight. 5 1/8" by 11 1/8" by 13 1/8". \$3.98 ppd. Miles Kimball, 100 Bond St., Oshkosh, WI 54901.



CHANGING TIMES

The best gadget ever invented for separating and dispensing nickels, dimes, pennies and quarters. Made of sturdy chrome it hangs on a belt—ideal for any business without a cash register. And imagine how a small boy would love one! \$3.98 plus 35c post. Anthony Enterprises, HG10, 585 Market St., San Francisco, CA 94105.



DELFT 1971

The Delft annual Christmas plate is always a beauty and collectors the world over cherish the plate of the year. 1971 plate shows St. Laurens Church in Rotterdam, dating from the Middle Ages and rebuilt after the bombing of World War II, 6 3/4" dia. \$12.95 ppd. Postmatic Co., HG1071, Lafayette Hill, PA 19444.

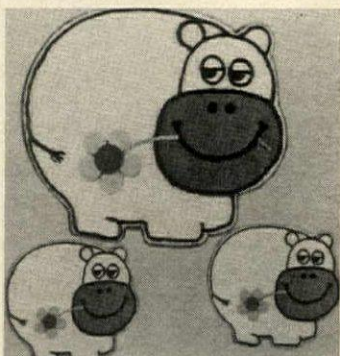

JUMBO SOFTIES

Momma hippo and her two baby offspring made of heavy carpet come in a kit with yarns and flowers to be glued on as shown in the picture. Fun to hang on the wall in the family room or den or even in the bathroom. Mom is 14" by 18". \$4 plus 35c post. Also available: owls, alligators, pigs, dogs and beavers. Annwalt Crafts, Box 366G, Blue Bell, PA 19422.

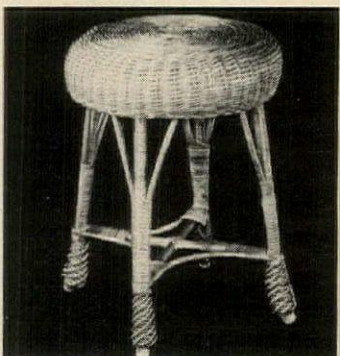

NATURAL WILLOW

Beauty of a stool made of heavy full willow is a delightful vanity stool or an ideal extra seat. Top 14" dia. and 19" high. Spray painted in H&G colors: Pineapple Yellow, Parrot Green, Space Blue, Azalea, Bittersweet, black or white, \$8.95. Natural, \$6.95. Ppd. Catalogue, 25c. Fran's Basket House, HG10, 89 W. Main St., Rockaway, NJ 07866.



Handmade Puffed Patchwork Pillows

are plump, hand-tufted put-togethers of pattern-on-pattern prints. A revival of a unique American craft perfect with any décor. Each 15x15" colorful cotton pillow filled with fluffy dacron. Indicate color for each pillow.

\$11.25 each Set of 4 \$41.00

Prices include postage • Money-back guarantee.

Send 10c for our brochure

Specify 4 colors, get 16 fabric samples 10c

APPALACHIAN TRAILS

P.O. Box 247 Dept. G9 Arlington, VA 22210

THE DIAMOND OF YOUR DREAMS

at a price he can afford



Buy Diamond Jewelry direct from one of America's well known diamond cutters. Pay only actual market price. We refund all monies unless your own appraisal shows value 1/4 to 1/2 higher.

Over 5,000 styles \$100 to \$100,000

Send for FREE 80-PAGE CATALOG.
EMPIRE DIAMOND CORP., Dept. 12
Empire State Bldg., New York, N. Y. 10001

NAME.....
ADDRESS.....
ZIP.....

Throw Away Extra Pillows



Enjoy new comfort with your back, shoulders and head gently raised and cushioned on this light buoyant foam wedge. Provides an even, gradual slope for more healthful, restful sleep. **Head Elevation** comforts diaphragm hernia, hypertension, acid regurgitation; breathing, bronchial and heart ailments. **Leg Elevation** eases varicose, circulatory and swelling leg discomforts. 27" long. Washable zipper cover. **FOAM-SLANT** comes in heights most often prescribed by doctors. Order 4" high for 2 pillow users \$10.00; 7 1/2" high for 3 pillow users \$12.00; or choose extra high 10" at \$15.00 or 12 1/2" at \$18.00. We pay postage & ship in 6 hours. N.J. residents add 5% tax. Send check to:

Better Sleep Inc. BOX 60
New Providence, New Jersey 07974
MONEY BACK GUARANTEE

The Gift for All Seasons



A Present with a Past

Any season is appropriate to share pride in the name which is a family's heritage. A beautiful gift to give or receive — the authentic Coat of Arms for your family name, in full color on an impressive 10 1/2" x 16" wall plaque. Handsome walnut wood-toned finish, three-dimensional sculptured effect. Only \$27.75. Satisfaction guaranteed or your money refunded in full. (Money back, too, if we can't trace a Coat of Arms for your name. We've found one for over 92% of the names sent to us.)

HALBERTS DEPT. HG-101
3687 IRA ROAD, BATH, OHIO 44210

Here's the coffee-lover's delight



Keeps Coffee Hot for 8 full hours

Your second, third or fourth cup of coffee will taste as good as the first... thanks to our magic, slim-look, handsomely designed Aladdin Server. It keeps coffee fresh, and piping hot, retaining all the rich aromatic flavor for hours, without reheating. Seamless glass thermos filler and smart insulated "float closure" keeps beverage hot, as lid stays closed when you pour. Holds full quart of hot or cold beverage at original temperature. Two tone beige color blends with any decor. \$6.95 ppd. 2 for \$12.95.

Mail orders filled promptly. Money back guarantee
Member: Better Business Bureau

COLONIAL GARDEN Country Kitchen
Dept. HG-10, 270 W. Merrick Road,
Valley Stream, N. Y. 11582

SHOPPING AROUND

BENTWOOD BEAUTY
Classic rocker is as in style in '71 as it was in 1890. Steam bent beechwood with hand-woven seat and back finished in walnut, black, white, or natural. Such comfortable elegance in seating today. \$89. Exp. coll. Big, beautiful catalogue, \$1. Door Store of Washington, HG10, 3140 M St. N.W., Washington, DC 20007.

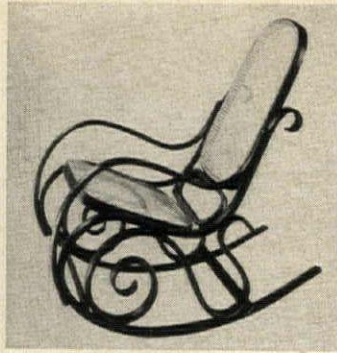

SCROLLED ESPAGÑOL
From Spain a black wrought iron rack in scrolled design shows off cooking tools, potholders. In the bath, it takes mini guest towels. 9½" by 6" rack with five hooks, \$5.95 plus \$1 post. Three fringed potholders in red, olive, mustard, turquoise, pink, orange or black, \$2.45 ppd. Henry R. Smith Studios, Dept. HG101, 39 Crestline Rd., Wayne, PA 19087.

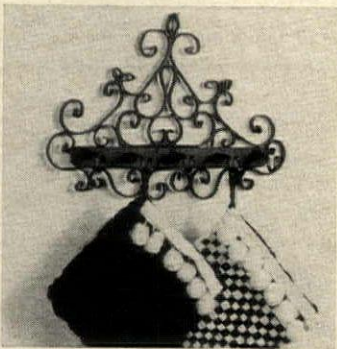

CIRCUS CUT-OUTS
Big top décor is always right for children's rooms. Colorful giant circus cut-outs make it easy for mom to do it herself. Tent poles, canopies and 2 ft. tall whimsical animals. Set of 48 plus decorating instructions, \$3.98 ppd. Frank Marmo, HG10, 1661 Griffith Park Blvd., Los Angeles, CA 90026.



BIRD CLIQUE TO STITCH

Birds in bright pastel colors make colorful subjects for a pair of framed pictures. Kit includes both designs on oyster Belgian linen; crewel yarns in pinks, blues, greens, yellows, lavender and brown; two green wood frames with gold trim; needle and instructions. Set of two pictures size 6" x 18" each only \$8.95 plus 65c pstg.



LADY KYOTO AND LADY DAISHI

Rich reds, pinks, golds, lavender and black are combined in these exquisite oriental pictures. Each kit includes design on white background, embroidery yarns and gold metallic threads, needle and instructions. Finished size 10" x 24". Lady Kyoto (left) \$5.95 plus 50c pstg. Lady Daishi (right) \$5.95 plus 50c pstg.



Send 25c For Our Exciting Art Needlecraft Catalog

The Stitchery

Dept. HG810, 204 Worcester Turnpike
Wellesley Hills, Mass. 02181

See New England's most complete art needlecraft display at our retail showroom

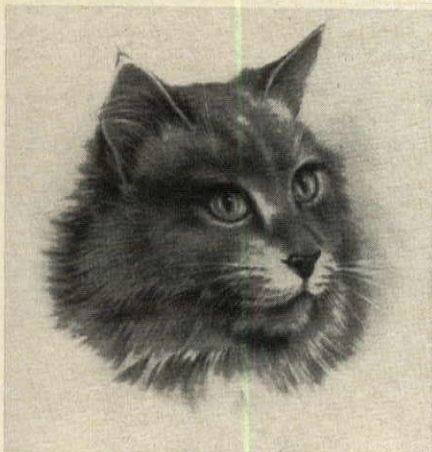

No. 516—Persian

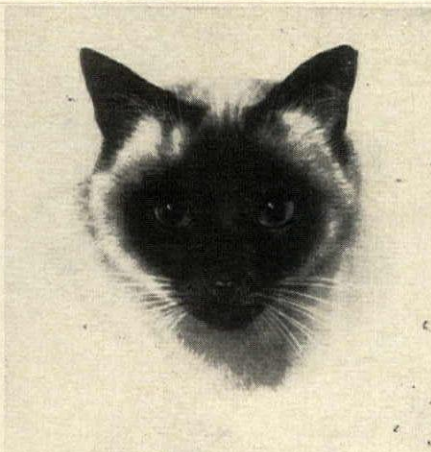

No. 518—Siamese

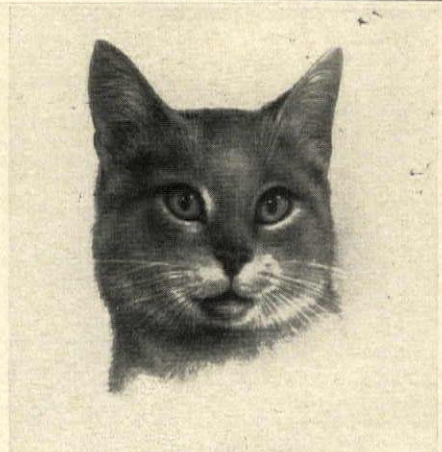

No. 517—Abyssinian



No. 520—Long Hair Tabby



No. 519—Tabby



No. 521—Short Hair Tabby

CAT CERAMIC TILES

White Ceramic Tiles used as wall plaques or trivets. Cork base with hangers, 6" x 6".
\$4.98 each + 40c Mailing Each or Set of 6 for \$24.98 + \$2.00 Mailing Each Set
Calif. Res. Add 5% Sales Tax.

ANTHONY ENTERPRISES, 585 Market, Dept. HG-101, San Francisco, CA 94105

SHOPPING AROUND FOR NEEDLECRAFTS AND HANDICRAFTS

SWINGING FROG
Imaginative designs are what we expect from the knowing needle of Suzy Girard. Fanciful frog is green and yellow on bright pink ground, plays a morning glory trumpet. Kit offers 10" by 10" hand-painted canvas with fine Persian wool, needles. \$26.50 ppd. Suzy Girard, HG10, 1042 Lexington Ave., NY 10021.

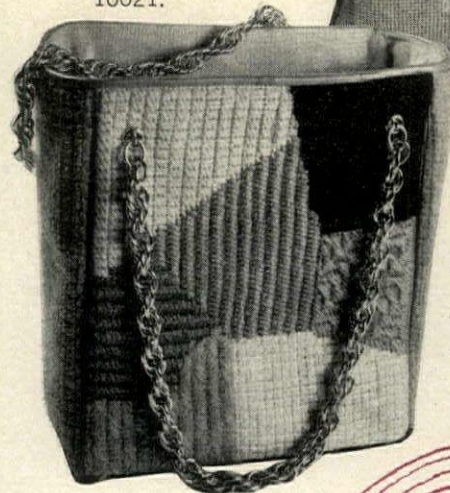

PATCHWORK BAG
Pattern with a purpose: learn new needlepoint stitches as you create this smart 8" by 7" by 4" bag. Each patch a different stitch, each a different color. Kit includes hand-painted #14 mono canvas, Persian yarn, instructions, needles. \$38.50 ppd. Catalogue, 50c. Three Bags Full, HG10, Manchester Center, VT 05255.



FOR NIMBLE NEEDLERS
Scissorie is grosgrain ribbon with scissors attached and felt pocket for thimble, strawberry for pins and needles. Always at hand as it hangs around your neck. Strawberry felt case is bright pink and green with Stork scissors, thimble, needles. Either, \$10 plus \$1 post. Nina Needlepoint, HG10, 860 Madison Ave., NY 10021.

sunny

Bright, warm colors of Gold, Orange and White make this 3-dimensional Felt Applique Wall Hanging a cheerful addition to any decor.

Fun and easy to make, kit contains felt, bur-lap, wood turnings, stuffing, dowel rod, needles, embroidery floss and easy to follow instructions.

Size 22" x 32". Only \$9.95 plus .50¢ postage and handling.

THE KIT BIT
P.O. BOX 4523
IRVINE, CA 92664

©TKB 1971

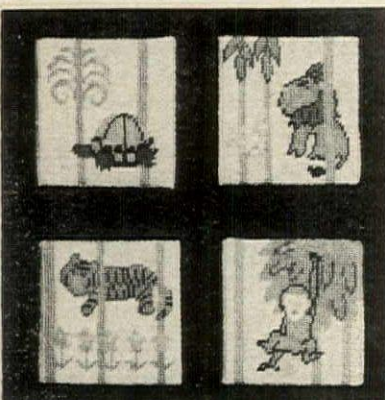
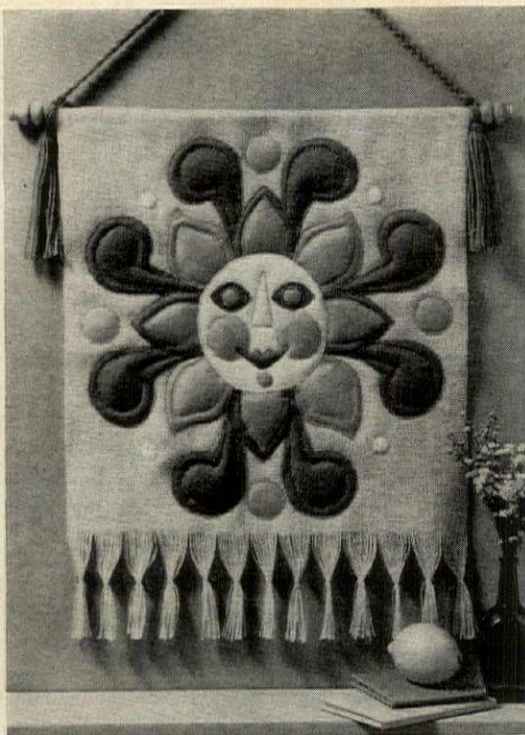

NEEDLEPOINT JUNGLE COASTERS

Peacock Alley presents its 1971 brochure featuring delightful nonsense like this set of Jungle Coasters as well as many new traditional and contemporary designs to please all tastes. Designs are hand-painted on white canvas with Persian yarns for you to work. Set of 4 Jungle Coasters, 14-mesh, in blue, gold and hot pink on yellow. . \$13.00 Ppd.

BROCHURE \$1.00

PEACOCK ALLEY
650 CROSWELL, S.E.
GRAND RAPIDS, MICH. 49506

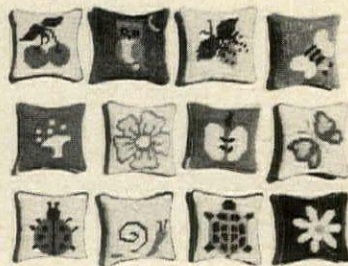

Pin cushions to stitch.

What a colorful idea for your sewing box! Needlepoint pin cushion comes with hand-painted canvas original design: choice of cherries, owl, strawberries, bee, mushroom, anemone, apple, butterfly, ladybug, snail, turtle, daisy. Front and back canvas, Persian yarn, needle, instructions included. 3 for \$12; \$4.50 each ppd.

KRICK KITS
Dept. HG-1071
61 Portland Dr.
St. Louis, Missouri 63131

New 40-page catalog \$1.00

CROCHET YOUR OWN BAG

SUPPLE SUEDE PLUS FINE JUTE

... a striking combination in this designer original bag for you to crochet. So simple you can make it even if you only know the "single crochet" stitch. Yet so unusual it will provide an interesting project for more experienced crocheters.

Kit includes pre-cut and punched chocolate brown suede, fine quality natural jute, cotton lining for bag and handle, beads, crochet hook and illustrated instructions. Bag is approx. 11"W x 12"H.

Request kit J102

\$9.95

plus 75¢ post. & handling

Pa. res. incl. 6% sales tax

Send check or money order. Sorry, no C.O.D.'s. Same day shipment if postal or bank money order is sent.

FREE CATALOG WITH ORDER, 25c ALONE.

DIVERSIKIT, INC.

P.O. Box 4479, Dept. 610
Phila., Pa. 19140

New from greengage



Recreate a tradition of the past. The Canton design in 5 shades of blue for the needlepointer. Kit includes hand painted, 12 stitch penelope canvas, Persian wool, Needle and instructions.

Available 12x16" or 13" octagon
\$35 each plus 75¢ postage
New brochure for \$1
greengage
P.O. Box 9683, Wash., D.C. 20016



BEVY OF BUTTERFLIES
Hand-painted butterfly jungle pattern in orange, watermelon and pink on yellow-green background or red on blue with white bamboo. 12" by 14" #14 imported canvas. Persian yarn, needle, instructions included. \$46.50 ppd. Catalogue with unique ideas from \$7.50. Send \$1. Kaleidoscope, Dept. H, Box 89, Sylvania, OH 43560.

MACRAMÉ IS NOW

All the makings for a smart braided belt. For just \$3 and your time and talent (little needed) produce a great look. Silky multicolored braid, instructions, diagram for knots. \$3 ppd. Decorative Adventures, Box 228 GE110, Abington, PA 19001.

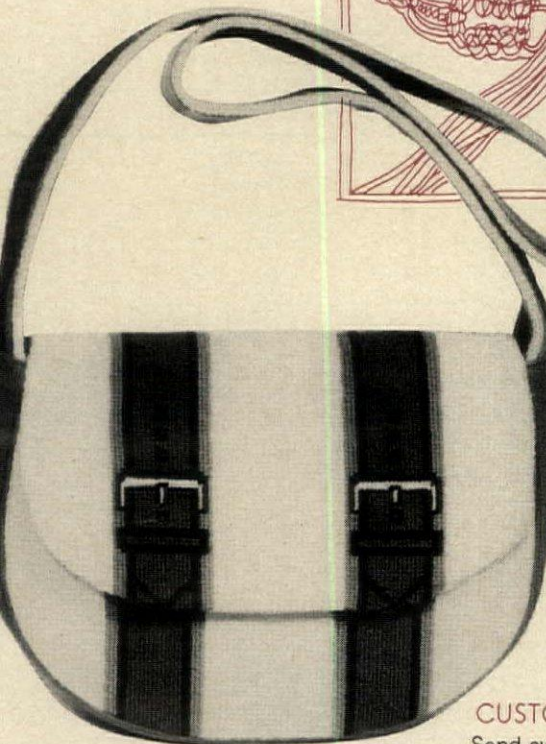

SUPER!

Smashing shoulder bag to needlepoint in red, blue and black on white. Kit of hand-painted #14 mono canvas, Persian yarn, needle, belt, buckles, instructions. \$55 plus \$1 post. Checkbook, wallet, glass case avbl. Catalogue, \$1.50. Needle Nuts, Dept. 1071, 3302 Mercer, Houston, TX 77027.

CUSTOM CANVAS

Send swatch or color description for custom painted canvas of "Summertime." 14" by 14" for pillow, frame, upholstery. With Persian yarns, #12 canvas, needles, instructions. \$38 ppd. Any custom piece; to inquire write Wild & Wooly, HG10, 17 Morse, Staten Island, NY 10314.

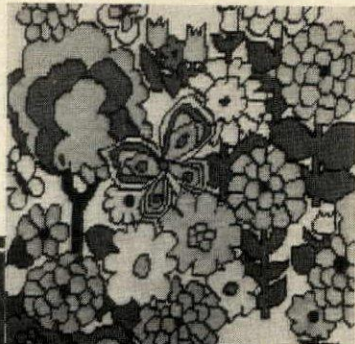

JULKLAPPSPRESSEN

Christmas Express wallhanging from Sweden with instructions for basic embroidery stitches, hanging rings. Glorious colors, enchanting figures on deep blue jute background. 17" by 33". \$18.95 ppd. Send \$2 for 40-page color catalogue refundable on \$25 order. Skön, GE10, 55 Lambert Lane, New Rochelle, NY 10804.



Needlepoint Therapy.



Handpainted homily for the harassed. Happifies the hassle of holidays, weddings, bar-mitzvahs — even women's lib meetings. Or give it to your favorite executive. Harmonious colors. Measures 19 inches by 16 inches. Canvas, needles, instructions, all the wool necessary to complete the piece — \$60. (California residents add 5% sales tax.)

Full color catalog of over 200 handpainted contemporary and period originals — \$2. Please write Dept. J-5.

haystack LTD., INC.

240 S. Beverly Drive, Beverly Hills, Calif. 90212



MONOGRAM TOTE BAG

A great new project and Xmas present idea. Needlepoint a 4" x 6" monogram patch for this 16" x 12" duck tote bag. Unique tote has top snaps, inside pocket and is available in navy/red, camel/black, red/navy. Price of \$13.95 includes tote, initialed canvas, wool and needle. When ordering clearly specify desired initials. Include \$.80 for mailing.

THREE BAGS FULL
Manchester Ctr., VT. 05255

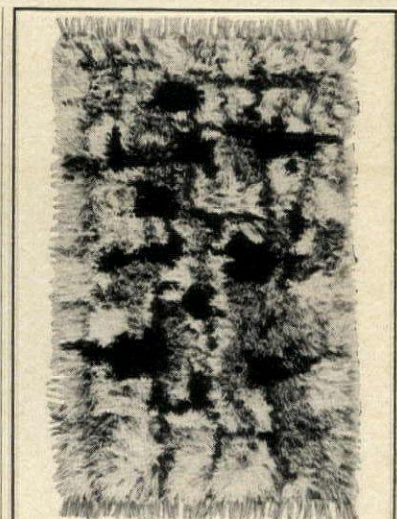

CUM nr. 73. This Houndstooth Design is available in 6 different Sizes and 3 lengths of Pile. Send \$1.00 for:

CUM RYA RUG

WALLHANGING AND EMBROIDERY KIT CATALOGS

TILLALLA INC. Box 484 Dept. G-10-71
New York, N.Y. 10021

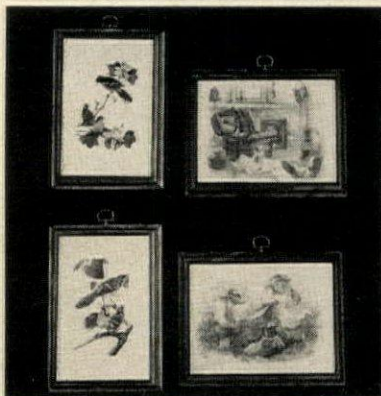

DECOUPAGE MADE EASY

Beautiful wall plaques for gifts or home decorations, easy to make with all materials and detailed instructions in kit. Includes 2 wood plaques 5 1/8" x 6 1/2", 2 prints, varnish, brush, etc. Specify choice of 2 Birds, or 2 Children Prints.

\$14.95 postpaid

J/C House of Decoupage
P.O. Box 502, Haddonfield, N.J. 08033



NEEDLECRAFT FROM A TO Z

Needlework Studio offers a unique monogrammed needlepoint kit for your fall decorating changes. Suitable for framing or making a pillow. Finished size measures 14" X 14". Design outlined on canvas and kit comes complete with instructions and the softest, finest yarn available. Background done in creamy white. Available with pink, blue or yellow flowers and initial. Please specify color and initial desired. Kit #K-ND1 \$19.95 plus 68¢ delivery charge.

Florida residents add 4%.

Countries outside U. S. add \$1.50.

Color sheets of other kits available of crewel and needlepoint kits\$2.

THE NEEDLEWORK STUDIO

Post Office Box 1754, Dept. G1071
Pompano Beach, FL 33061

TURN THE PAGE FOR MORE SHOPPING AROUND FOR NEEDLECRAFTS AND HANDICRAFTS

SHOPPING AROUND FOR NEEDLECRAFTS AND HANDICRAFTS

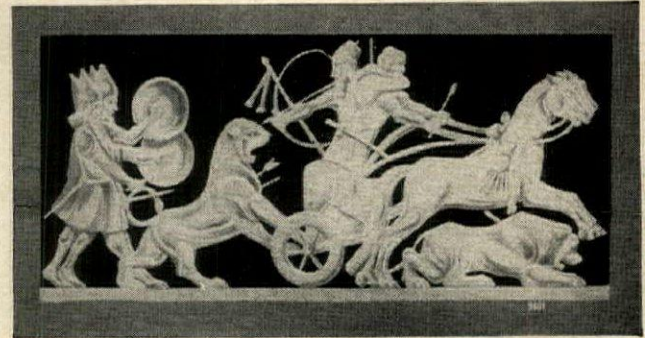

CLASSIC CANVAS

Roman chariot design has great motion and its size and shape make it unusually adaptable. Handsome wall décor, perfect for piano bench or window seat. In elegant golden tones on rich brown background. 35 1/4" by 16 3/4" hand-painted canvas with fine wool yarns. \$25 plus \$1 post. Catalogue, 25c. Yarns Galore, HG10, 42 Miracle Mile, Coral Gables, FL 33134.

STOCKING STITCHES

Santa's sidekick, a super stocking that once needled and finished with backing, goes up on the mantel year after year. Red, white and gold on blue. Finished size is 15" long with 9" foot. Kit includes hand-painted canvas, Persian yarn, needles, instructions, and tote bag. \$30 ppd. Catalogue, \$1. Yarn Barn, HG10, 16561 Ventura Blvd., Encino, CA 91316.

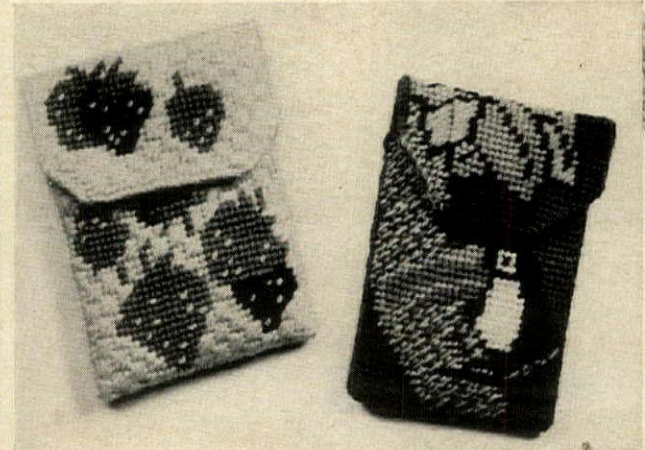
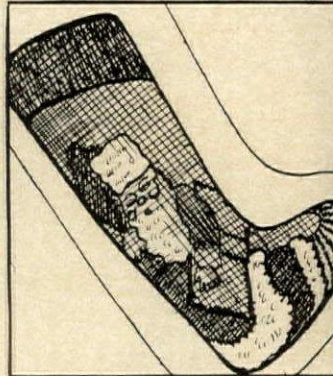

CREDIT CARD CASES

Stitch a bunch of pink and red strawberries on a pale pink background. Or go wild with the jungle design on bright blue. Kits include imported canvas and yarns, needle and instructions. \$10 each plus 75c post. Brochure, \$1. Greengage Designs, HG10, Box 9683, Washington, DC 20016.

CROCHET CACHET

Handsome handbag in a fascinating kit that includes pre-punched suede, fine jute, cotton lining for handle and bag, crochet hook and illustrated instructions. When you finish working with the jute and suede which is really fun, you'll have a great 9 1/2" by 11" shoulder bag. All this for \$9.95 plus 75c post. Diversikit, Inc., Dept. G10E, Box 4479, Philadelphia, PA 19140.



13" Rd. or Sq.
\$30.95 ppd.

10" x 14" \$25.95 ppd.

NEW FROM THE YARN BARN

Two more of our original designs for you to needlepoint. Choose either the bright multi-colored "Mushrooms" or the "Tiger" smiling from his bed of pink blossoms. You'll delight watching them come alive as you stitch. Kit includes hand-painted canvas, Persian yarns, needle, instructions and tote bag. Creamy off-white backgrounds.

Send for NEW catalog \$1.00

Calif. res. add 5% sales tax

YARN BARN

16561 Ventura Blvd., Encino, Calif. 91316

Pic-A-PocKIT in Needlepoint for YOUR MAN'S JACKET

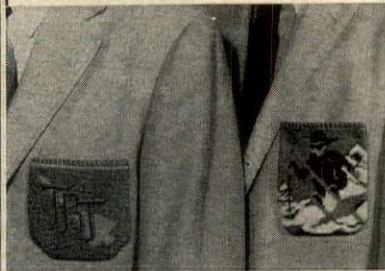

Professionally-designed kits for skiers, sailors, golfers, and tennis players, or monograms. Specify jacket color. Monograms—up to three initials.

Kit contains handpainted 13 mono canvas, needle, Persian yarn and complete needlepoint and kit instructions.

Pocket easily attached to jacket with no special finishing.

\$12.95 plus \$.35 postage

Personalized designs, such as group insignia or monograms with professional or pastime symbols can be provided; write with particulars. Design features and price will be forwarded. Finished pockets also available.

Pic-A-PocKIT

P.O. Box 662

Newton Lower Falls, Massachusetts, 02162



YORKSHIRE TERRIER NEEDLEPOINT DESIGN

He's a darling in browns and grays with touches of greens, blues and white on a cream background. A masterpiece of originality. This 12" x 12" pillow design is hand painted on #12 imported canvas. Shipped complete with fine imported yarn, needles and easy-to-follow instructions. SP-109 \$36.00 ppd.

MONEY BACK GUARANTEE

Send 25¢ for brochure describing our complete line of unusual needlepoint designs.

4 River Road, Worthington, Mass. 01098

Margot Hamilton
NEEDLEPOINT

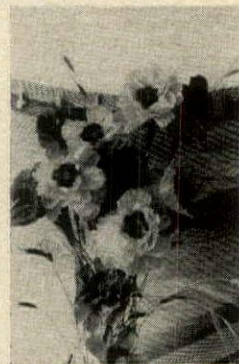

(AMAPOLAS) PAPER FLOWERS

Like garden flowers, these hand-made papier maché flowers with cactus fibre center will cheer your day. Arrange them in smart patterns. A great gift idea! Colors—pink, orange, gold, lime green, yellow, black, white, blue and purple. 8 1/2" dia., 22" long.

\$1.25 ea. post pd.

THE ROYAL RETREAT

HG436, 2700 Nielson Way
Santa Monica, CA 90405



MAKE YOUR OWN AUTHENTIC PIONEER PATCHWORK QUILTS AND PILLOWS.

Yarn-tied quilts work up very quickly and have a puffy, comfy look. Pillows zip up in less than an hour. Both may be worked by hand or machine.

Quilting instructions include a diagram for joining squares and directions for quilt tying and finishing. Materials include seven happy prints, snappy border colors of skipper blue and lemon peel yellow, needle and yarn for tying. All fabric is machine washable and dryable acrylic cotton and polyester blend.

Pillow - 16" square \$4.95
Coverlet Quilt - 42" x 88" \$19.95
Large Quilt - 58" x 88" \$29.95

(For extra wide size, join two same size quilts.) Specify either yellow or blue backing. Batting and pillow form not included. Add 75¢ postage and handling for quilts, 50¢ for pillow. Utah Res. add 5% sales tax.

Julie's Barn
P.O. Box 8375, Salt Lake City, Utah 84108

ELEGANT NEEDLEPOINT

From our artist's hand to you!

Enhance your home with a magnificent pillow or hanging!

"BAMBOO"

15" x 15" \$38 ppd.

tones of one color, butterflies in your accent colors (up to 4 colors).

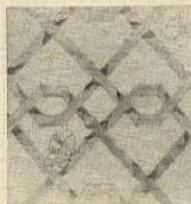

"FLOWER PATCH"

12" x 12" \$33 ppd.

checked background (white and one color), multicolored flowers.



Send swatches or specific color descriptions. No COD's. Kit includes: finest Persian yarns, custom painted 12 pt. canvas, needles, instructions.

WILD & WOOLY

57 Willow Pond Rd., Staten Island, N. Y., 10304
New York Residents add applicable Sales Tax.

THANK YOU FOR YOUR ORDER!

CHRISTMAS EMBROIDERY
 Order this enchanting Scandinavian embroidery hanging now and make the focal point in your holiday décor. Kit comes with rod, cord, yarn and jute background, 15¾" by 21¾". Blue ground with yellow, green, red and white. \$18.95 ppd. Catalogue, \$2. Tillalla, Inc., HG10, Box 484, NY 10021.

NEAT FOR NEEDLERS

If stitching strikes your fancy (and who of us isn't working on one such project or another?) this around-the-neck magnifier is marvelous. Leaves hands free! \$5.25 plus 68c postage. Catalogue \$2. The Needlework Studio, HG10, Box 1754, Pompano Beach, FL 33061.

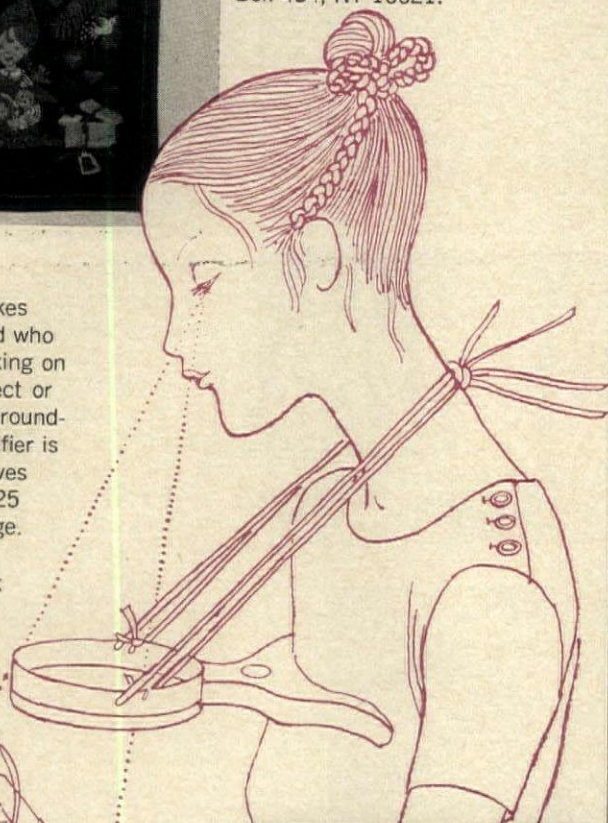

PILLOW PAIR

Gay gingham blue and white checks with red tulips or yellow daisies all hand-painted, ready to needlepoint with three-ply Persian yarns, needles, instructions. 8½" by 9½". \$20 each ppd. Catalogue \$2. Haystack, Ltd., inc., HG10, 240 So. Beverly Dr., Beverly Hills, CA 90212.

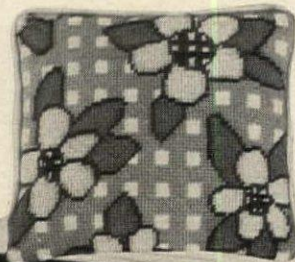

NOW NEEDLEPOINT

Busy Work offers a fascinating collection of contemporary pieces with superb kits of exceptional quality. Deft designs all hand-painted on the finest imported canvas with bound edges, Persian yarns, needles. Send \$1.25 for catalogue. Busy Work, HG10, Box 1389, Phoenix, AZ 85001.

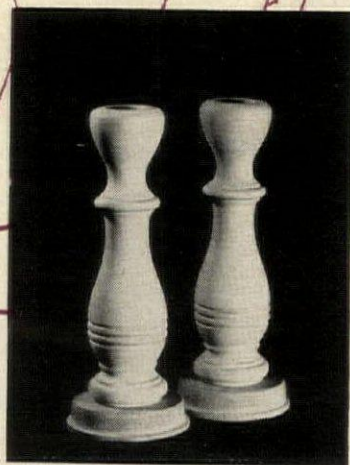

CANDLESTICK MAKER

Unfinished hardwood candleholders for you to oil, stain, paint or antique. Or why not try découpage? Or a special Christmas motif? 7" high and just \$3.20 the pair ppd. The Browse Shop, HG10, Avon, CT 06001.



Personalized NEEDLEPOINT SAMPLER

Cherish her childhood in this unique personalized sampler. Complete kit includes 15" x 15" canvas, Persian yarns, needles, chart for letters and full instructions. Choice of Hot Pinks or Yellows with Orange.

Also available for "Little Boys" in Yellow-Greens or Blues. Please specify blonde, brunette or redhead.

\$49.50 ea. ppd.

BUSY WORK

NEEDLEPOINT STUDIOS, INC.
 P.O. Box 1389, Phoenix, Ariz. 85001

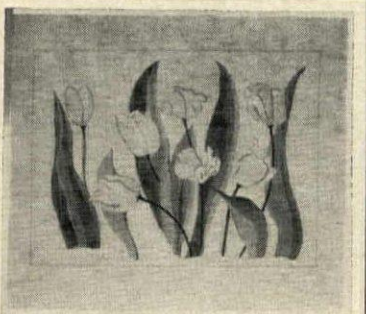

Needlepoint "A Garden of Tulips"

Lemon yellow tulips grow among leaves of apple, lime and yellow-green with dark green stems on pale aqua background. 13" x 18½" on #12 or #14 imported white canvas—Pat Persian wools, needle, instructions.

\$57.50 postpaid.

Ohio residents add 5% sales tax.

Additional color combinations, hyacinth and purple tulips or red tulips on white background; lime, pink and hyacinth tulips on brilliant orange background. Same design with 2" border—stunning as a wall hanging—\$70.00. \$1.00 for catalogue of imaginative designs.

We will custom paint any of our designs—Please write for full information.

KALEIDOSCOPE

Box 89, Sylvania, Ohio 43560

THE SIX FOOT

Swinger LAMP KIT

Created exclusively for Craftings by Robert Burridge. They can be used "as is" in their classic design or you can craft this soft, washable nylon fabric with tie-dyes, batiks or appliques. The "Swinger" can be assembled without sewing and comes complete with electrical parts plus a two way dimmer switch. Money back guarantee.

Only \$19.95

Plus \$1.00 for postage
 PLEASE SEND CHECK OR MONEY ORDER TO:

Craftings

3 GRAND AVE. ENGLEWOOD, NEW JERSEY

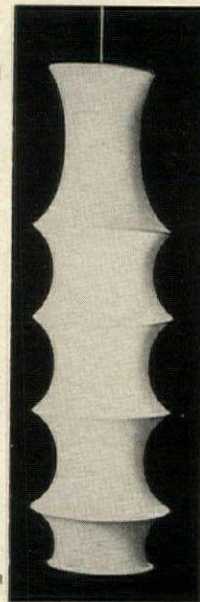

EMBROIDERIES



A PAINTING OF SPRING. The paints are colored threads. Turquoise. Green. Yellow Orange. Brown. Lavender. White. The canvas is green. The brush is an embroidery needle. And you can paint the painter with nothing but ordinary embroidery stitches, and hang it on a proud wall. Order #0374 13"x20". \$18.95. Send \$2 for 40 page full color catalog.

skön EMBROIDERIES
 55 Lambert Lane
 New Rochelle, N.Y.
 10804 Dept. GE 10

PAGOD: Shades of Blue on White.



RYA KITS

NEW 1972 COLLECTION. We've done it again. Awarded 10 gold medals. Now you do it. One simple stitch makes our pre-started rya hangings, rugs or cushions. Kits imported from Sweden feature lustrous rug wools, easy to follow charts and English instructions. Send \$1 for color catalog.

skön RUG CRAFT
 53 Lambert Lane
 New Rochelle, N.Y.
 10804 Dept. HG 10

NEEDLEPOINT NEWS



You'll love our stunning original new patchwork design in spicy decorator colors. Hand-painted on French mono canvas; finest Persian yarn. "PATCH PAZAZZ": 16 x 16 in. \$66.50; 14 x 14 in. \$46.50, P.P.D. N.Y. Res. please include sales tax. Brochure, \$1.00

SUZY GIRARD INC.

1042 Lexington Ave.
 New York, N.Y. 10021

WICKER WIZARDRY

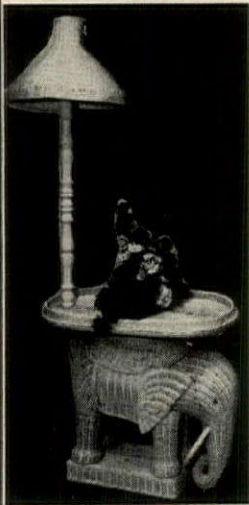

Mr. Penguin. Will hold your laundry, toys, wastepaper or beautiful as a planter. 12" x 12" x 29"—\$31.95 ppd.

DECORATOR COLORS

White, Black, Gold, Royal Blue, Light Blue, Avocado, Lime, Kelly, Red, Raspberry, Orange, Hot Pink, Light Pink, Brown, Mustard, Yellow, Purple, Turquoise, Lilac, Natural.

62 page catalog and color chart \$1.00.

Elephant Shaft Lamp Table. 16" x 22" x 36"—\$39.99. Also dogs, cats, donkey, snail, turtle and rhino. Table without lamp—\$27.99 (express collect).

Cage Shaft Table. With 21" glass shelf, 6' tall. Beautiful in living room, three way switch. \$69.95 (express collect).

Joan C. Luchs

8010 Old York Road, HG-10

Elkins Park, PA 19117

SHOPPING AROUND

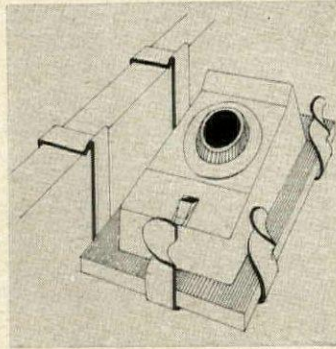

BLANKET CONTROL

Electric blanket control guard of metal clips to bed where most convenient to reach when reclining. Clips bend easily by hand to adjust to bed rail. To keep electric cord off floor, out of way, excess cord can be wound around holder. \$1.49 plus 20c post. Anthony Enterprises, HG10, 585 Market St., San Francisco, CA 94105.



DOLL DISPLAY

Adjustable doll stands disappear from view when doll is in place. Sound and sturdy, it keeps dolls safe and pretty, free from wrinkles and falls. Durable baked enamel finish on 3" steel base. For dolls 6½ to 11" or dolls 8 to 14". Specify either size, \$1 each; three for \$2.50. Ppd. Downs, Dept. 1410, Evanston, IL 60204.



WHISPERING PINES

No fooling! Here's a whispering pine forest. Unit sound screens discord and clamor. Uses as much current as a night-light and gives years of maintenance-free service. No more noise pollution. Zippered travel case is leather-like vinyl. \$5. One speed, \$22. two speed, \$28. Ppd. Marpac Corp., HG10, Box 658, Wilmington, NC 28401.

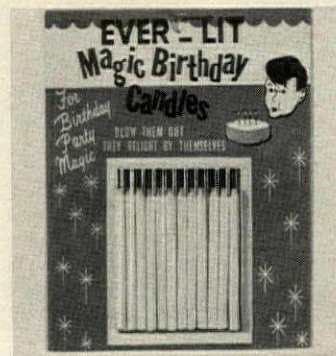

BIRTHDAY MAGIC

Light these crazy candles and when the birthday boy blows, they stay lighted. Tough for wishers but fun for watchers! You have to pinch the wick to put them out like fine tapers. Pink, blue or white. A package of 12 guarantees giggles. \$1 plus 15c post. Anthony Enterprises, HG10, 585 Market St., San Francisco, CA 94105.

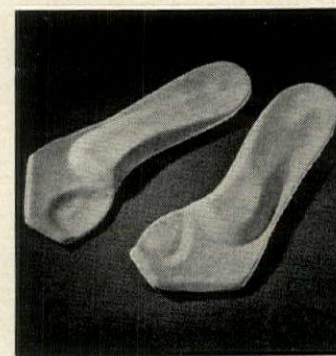

COMFORT NOW

You'll be walking on air with Pedi-Mold insoles that add spring to every step. Foam rubber and leather mold is comfortable and good for you—your feet get fatigue-chasing support. Specify flat or high heels; men or women, shoe size and width. Pair, \$3.50; two pairs, \$6.50. Ppd. Pedi-Mold of New York, G10, 9 E. 46th St., New York, NY 10017.

WISE OWLS

Burnished metal owls, nicely detailed. Antique finish. Just the look you seek for informal settings. Let them keep you company in the den, kitchen or anywhere. Overall 20 inches. 1 Pair.

No. 174—Wise Owls Metal Plaque \$5.98 + 45c Mailing Each Pair

Calif. residents add 5% sales tax. Satisfaction guaranteed.

Anthony Enterprises
585 Market St., Dept. HG-101
San Francisco, Calif. 94105

CORNER HAMPER TABLE

A Fine Piece of Furniture To Make Short Work of Washday Blues



Where do you hide your laundry? In some dark, inaccessible corner? Put it in this fine louvered cabinet that hugs any corner, holds a week of family wash in big tilt-front bin & removable poly inner basket. Handwashables, supplies store in upper drawer. 30H 28W 19D. Solid pine in honey tone or maple, antique pine or walnut finish. \$34.95. Exp. Col. KIT: \$28.95. Postpaid. Add \$1. W. of M.

SEND 25c FOR NEW 76-PG. COLOR CATALOG—OVER 1200 ITEMS—

Include Zip Money Back Guarantee



Dept. G10-1C
North Conway, N.H. 03860

GORGEOUS, HAND-CRAFTED SILVER GUATEMALAN EARRINGS

Intricate and exquisite. Beautifully designed in 6 different styles plus a wedding ring which fits any size finger and which can be worn with both necklaces and scarfs. Available for pierced or non-pierced ears.

- No. 1 (far left) Hand-engraved large silver ball. \$5.25
- No. 2 (top left) twisted silver button earrings—\$5.50
- No. 3 (top center) twisted silver loop—\$5.75
- No. 4 (top right) dainty woven silver balls—\$5.25
- No. 5 (bottom left) Cut-out large silver ball—\$5.75
- No. 6 (bottom center) Delicate and lovely circle—\$5.25
- No. 7 (bottom right) Traditional wedding ring—\$5.00

Send cash, check, money order to

BARBARA BAXTER GIFTS
P.O. Box 581, Arcadia, Ca. 91006



THE FIRST EDITION HUMMEL CHRISTMAS PLATE 1971

We are pleased to offer the first ever M. J. Hummel Christmas plate produced to commemorate the 100th anniversary of W. Goebel Hummelwerk which was first produced in 1871. This beautiful matt finish plaque depicts an angel in green on a cream background so typical of all the delightful Hummel figurines. This 7½ inch plaque is boxed for post. A necessary first edition for all collectors. \$15.75 ppd. Surface mail and \$17.00 ppd. Airmail. For these and all other collectors items write to:

FRANCIS SINCLAIR LTD.
Georgian House, Hallgate,
Doncaster, England

World's Masterpieces in Replica

PRE-HOLIDAY SALE
at this SPECIAL PRICE

Famous sculpture for your own home or as a gift of distinction

() F807—DAVID by Michelangelo. Original in Florence. Antiqued bronze finish. Height 14". Reg. \$14.95

THIS MONTH ONLY

\$7.47

Add \$2.00 for post., ins. and pkg.

10-Day money-back guarantee

Send check or M.O. or charge your Diners' Club or American Exp. acct.

Send for FREE catalog PLUS bonus offer. (please include your zip code no.)



WYNN'S

FINE ARTS STUDIOS
Dept. L-101, Lawrence
Road, Kings Park, N. Y.
11754

SHOPPING AROUND

SOME SCOOP

Dip, drain and serve in one action with an oval scoop colander. Metal bowl is 6 1/4" across, 9" long, 3" deep with black plastic handle. You'll cope beautifully with deep fried foods, spaghetti, all vegetables. Faster, neater, safer. \$3.89 ppd. Order from Miles Kimball, 100 Bond St., Oshkosh, WI 54901.

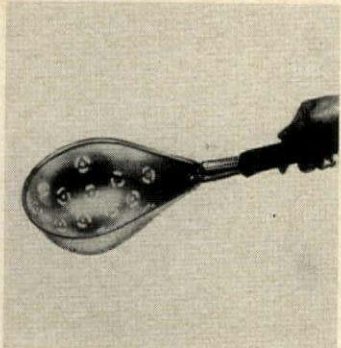

SUPER SOURDOUGH

Any San Francisco fan knows the joy of fresh, crispy sourdough bread. "Old Fashioned San Francisco Sourdough Starter" shares these secrets—ingredients, recipes, directions. Make this specialty your own with delectable breads, rolls and waffles. \$1.98 plus 15c post. from Anthony Enterprises, HG10, 585 Market St., San Francisco, CA 94105.



CLEARLY USEFUL

Picture a pitcher that holds a big 48 ounces for serving a perfectly chilled martini! Picture it again chock-full of Autumn leaves on a coffee table. Handmade in Europe in a Paul Revere tankard shape. It's the perfect answer to any gift problems. \$4.50 plus 50c post. Added Touch, 12H Water St., Bryn Mawr, PA 19010.

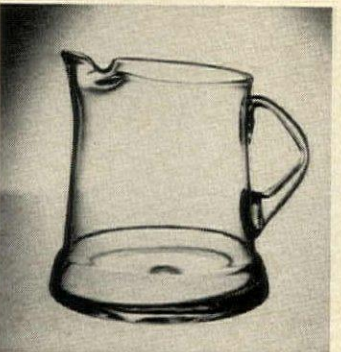

IT'S A DOG'S WORLD

Chemically-treated Train-O-Mat is subtly odorized to attract pooch, make housebreaking easy, save carpets. No messy newspaper. Mats are disposable, 18" plastic holder washes easily. With two months' supply of disposable mats, \$4.98; six months', \$6.98. Add 50c for pole. Ppd. G & G Research, HG10, Box 8395, Dallas, TX 75205.

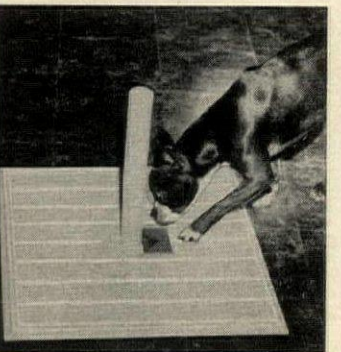

NEAT FOR NAPKINS

A lucite holder is clearly a good idea for carting napkins from here to there and keeping them in folded trim during the process. There's casual entertainment value too when the picnic or informal approach is on the schedule. 7 1/2" sq. by 7 1/2" h. \$4.95 plus 75c post. From Elizabeth McCaffrey, HG10, Northport, NY 11768.

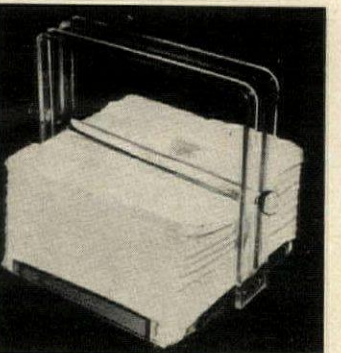

OWN YOUR TELEPHONE — PICK YOUR STYLE!
SAVE MONEY EACH MONTH!



Trendline PHONE

Be first with the newest trend in phone elegance without adding to your phone bill! Cradles in your palm for easy dialing, talking and listening. Nothing to install; just plug into phone jack and use.

Illuminate dial with mini-transformer @ \$2.99 add'l.
Colors:—White, green, blue, beige, pink, turquoise, ivory, black, red.
With ringer, dial, coil cord & plug. **\$59⁹⁵** Add \$1.50 pstg/hdlg

MODERN DESK PHONE
—Choice of Colors—



\$19⁹⁵

Complete with ringer, plug and cable

Luxurious styling to accent a conversation piece. Highlight your room with an extra convenient phone. Colors to fit your decorating creativity: beige, green, red, blue, black, white, ivory, pink, grey, yellow.



Exciting Conversation Piece!
Decorator's choice!
"SPEAK-EASY" PHONE

\$39⁹⁵

Complete with dial, buzzer, plug & cable

As famous as raccoon coats and the roaring '20s. But more functional. Stands 12" high and is crafted with dial in the base. Black. Available in old-fashioned brass finish @ \$10 add'l.

BATHROOM EXTENSION PHONE



\$19⁹⁵ Complete with coil cord, plug & cable.

Be the person to have everything! Here is comfort-plus! No need to step out of the shower when the phone rings. Colors: beige, white, black, red, grey.

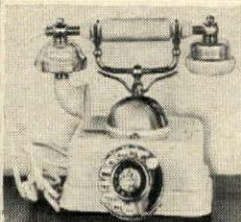

FRENCH CRADLE PHONE

\$49⁹⁵

Complete with ringer, decorated dial, plug & cable.

Truly authentic in style and performance! Here is genuine elegance!

Ready for use. Gold & ivory; gold & black; all gold.

Ericofon SCULPTURE PHONE
1 PIECE/2 POSITION



\$39⁹⁵

With plug, dial and cable.

Swedish beauty winner of ultra-contemporary design, stands like a statue; rests horizontally for easy dialing. Coordinate color: white, green, blue, red, ivory, yellow, pink. (Buzzer, if needed @ \$10 add'l.)

25 FT PHONE EXTENSION CORD

\$2⁹⁹ EACH

with 4-prong plug & jack attached
Add 60c pstg./hdlg

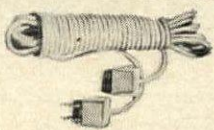

Save time and energy! Make your phone reach all parts of room. Off-white color.

CINDERELLA PHONE

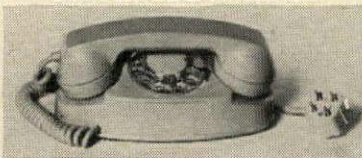

\$29⁹⁵ Complete with dial, plug & cable.

Styled low and sleek for today's fashionable decor. Lightweight and graceful. Have the convenience of another phone without increasing your phone bill. Colors: white, beige, grey, blue, green, pink.

Ringer Box if needed @ \$6.95 add'l.

DESK DIAL PHONE

With dial, plug, ringer and cable. **\$8⁹⁵**

ASSORTED STYLES

Regulation phone for the home at a budget price! Enjoy the comfort and convenience of an additional phone without increasing the cost on your monthly phone bill. Black. Fully equipped and ready to plug in and use.



● USE THIS HANDY ORDER FORM ●

Send check or money order for prompt delivery. Add proper sales tax.

METROPOLITAN TELETRONICS CORP.

Dept. HG 10, 35 WEST 35th ST., NEW YORK, N.Y. 10001 • Phone: LW 4-4030

Please send the following items:

.....
.....
.....
.....
.....
.....

Add \$1.50 pstg and hdlg charge for each phone ordered.

Be sure to add proper Sales Tax.

(Indicate 2nd choice when specifying color)

Am't enclosed:

NAME _____

ADDRESS _____

CITY _____ STATE _____ ZIP _____

\$.....

STATE _____ ZIP _____

Early Americana Re-Created!
BEDSPREAD FRINGED COLONIAL CURTAINS

Recapture all the warmth and charm of Old Colonial America at EVERY window with these lavishly fringed Old-New-England-inspired beauties that are so great with Antiques, Maple Furniture, Heirloom Spreads.

Made of Snowy White or Natural Unbleached MUSLIN, they're trimmed with 4" DOUBLE KNOTTED bedspread fringe and feature the versatile 39" long CUTAWAY SWAG top-curtain (pictured with tier curtain at right).

Hang as: Swag-on-Tier (as shown), Tier-on-Tier or Tier and Valance. Swag is split in center for adding one or more valances on extra wide windows. Swags, tiers and valances are EXTRA WIDE—80" to the pair.

Order style "Betsy"
Avoid delay: Specify white or natural
OLD COLONY CURTAINS, HG-103, Box 787, Westfield, N. J. 07090
Money back guarantee. Send check or Money Order. No COD's.
Delivery in N.J. add 5% Sales Tax.

24" Tiers \$5.00 pr.
30" Tiers 5.00 "
36" Tiers 5.25 "
45" Tiers 5.75 "
Swag Top 5.75 "

Matching Valance 11" x 80" ... \$3.00

Add 75c postage to each order

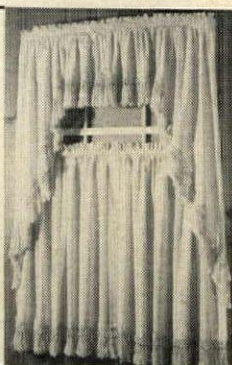



MATTERHORN HAT

Comfortable, Tyrolean-style all-weather hat for men. Quilted Nylon sheds water. Pull-down earflaps for warmth. For sport & casual wear. Color choice: Red, Olive, Gold, Navy. Sizes: S, M, L, XL.

\$7.95 ppd.

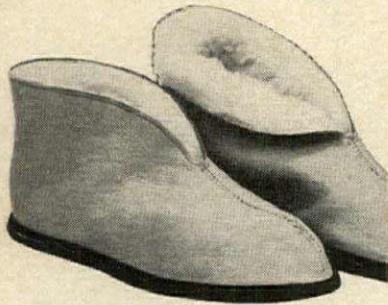

MEN'S RELAXIN' SLIPPERS

Step into these and a new world of luxury. Natural color deerskin with sturdy, flexible sole and high collar. Feet and ankles are cradled in the softness and warmth of the lush Orlon Acrylic pile lining. The man of the house will turn to these when day is done. Great after skiing. Whole Sizes 7-13.

\$10.00 (add 35c handling charge).

RED GLOVES

Heavy-duty red deerskin suede with thermal knit lining . . . warm, snug in sub-zero weather. Men's sizes: S, M, L.

\$4.95



Free Catalog

DEERSKIN TRADING POST

Dept. G, 119 Foster St., Peabody, Mass. 01960
Zip Code Required!



THE HOTTEST ICERS TO BE FOUND

Icers and Liners of crystal clear glass are as pretty as they are useful. Perfect for serving seafood and cold soups. Ideal for frozen desserts, fruit compote, ice cream and sherbert. Ideal for home or as a gift. Size 4 1/2" a set of four **\$4.00**. Eight for **\$7.50**, postpaid. Money-back-guarantee. Too, order REM Imports new and unusual items—25c.

REM IMPORTS

Box 184-HG10-Monroeville, Pa.—15146

The hard to find s-t-r-e-t-c-h PANTS



Double knit of 100% Nylon. Smooth, effortless pull-on style. No zippers. Machine-washable. Black, Brown, Navy, Green, Grey.

Sizes 8-20 **\$12.90**

Sizes 38-46 **\$15.90**

Plus 60c post.

\$5 deposit for COD Satisf. Guar.

VICKI WAYNE

610-HOP-So. Country Club
Tucson, Arizona 85716

SHOPPING AROUND

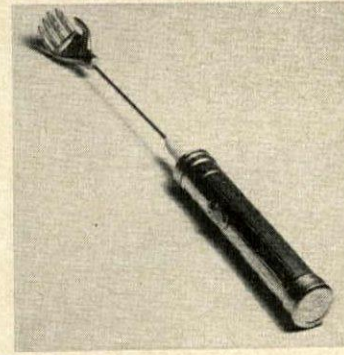

BACK TO BACKS

When your arms can't reach that itchy spot, grab for Anthony's battery operated back scratcher. Ah . . . that *does* feel good! Power motor vibrates soothingly. 15" l., \$2.98 plus 30c post. Two batteries incl. A tremendous gag gift for man whose mate is always not up to scratch! Anthony Enterprises, HG10, 585 Market St., San Francisco, CA 94105.



SMART BOOT BUY

Side-laced boot adjusts comfortably to your calf. Orlon pile lining, sure-grip rubber sole for safety on snowy streets. 1 1/8" heel. Black leather, 5 to 12 for B through EE. Also brown leather in B and C. Half sizes except 11 1/2. 5-10, \$30.95; 10 1/2 to 12, \$31.95. Add 75c post. Free catalogue. Solby Bayes, HG10, 45 Winter St., Boston, MA 02108.

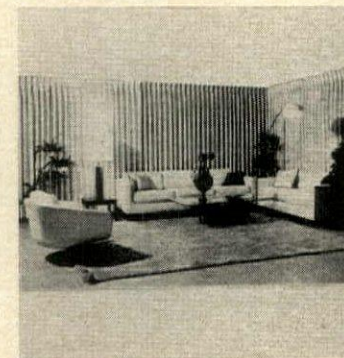

EXOTIC WINDOW WALLS

Homespun House has those marvelous 10-foot-wide fabrics that make seamless draperies covering window walls. Choose cottons, open weaves or polyesters that never need ironing. Natural, white or color-matched to sample. \$3.98 yd. up. Brochure, swatches, 50c; air mail \$1. Homespun House, 9036-HG10, Lindblade, Culver City, CA 90230.

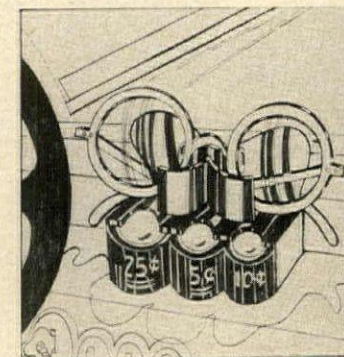

COMMUTER'S CADDY

Whiz through those "exact change only" lanes—you'll always have coins ready with this self-stick car caddy. Nickels, dimes and quarters find their nooks. And so do specs! Swap sunglasses for regular lenses without fishing in your pockets. \$1.29 plus 15c post. Anthony Enterprises, HG10, 585 Market St., San Francisco, CA 94105.



AMAZING CATALOGUE

Ingenious designs for 19th century toys, games, puzzles and gadgets abound in 86-page 8" by 9" catalogue from George Bestelmeier. Fascinating engravings reproduced from original copper plates. \$5 ppd. Small catalogue of old-fashioned toys, doll house furniture, free with order or 25c. Federal Smallwares Corp., HG10, 366 5th Ave., NY 10001.

50¢ buys hand-rubbed effect without rubbing



Try this 1/2-pint sample of Pen-Chrome Clear Satin Finish on previously finished or new wood. See how easily this special formulation brings out the deep-down natural beauty.

SPECIAL OFFER! Limit one can per customer. Send 50¢ to The O'Brien Corporation. Dept. G-10, South Bend, Indiana 46621.

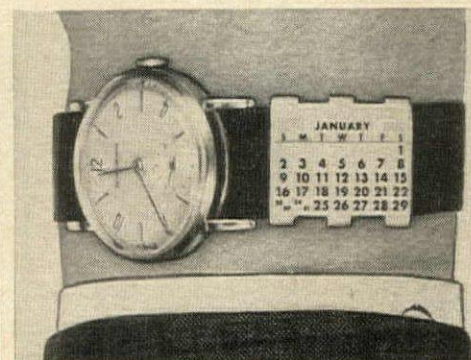

INSTANT WRIST CALENDAR

Now always have each day of the month at your "finger tips." 12 monthly metal clips attach to watch band. Reversible with gold and silver sides to match any watch. Set starts with month after order.

Calendar Set

\$1.98 + 15c Mailing Each

Calif. residents add 5% sales tax. Satisfaction guaranteed.

Anthony Enterprises

585 Market St., Dept. HG-101
San Francisco, Calif. 94105

SHOPPING AROUND

STOOL FOR ALL SEASONS

Native hardwood stool is just right for the bar, kitchen, family room. Use it for eating, sipping, games or craft work. 30" h., \$6.50; 24", \$6; 18", \$5.50—all unfinished. Add \$2 for pine, walnut, black, white, red or green. Exp. coll. Minimum order two stools. Catalogue, 25c. Marion Travis, HG10, Box 292, Statesville, NC 28677.



SAVE 20%

For a limited time only silver plating is being done at sale prices. All work is 100% guaranteed; dents are removed at no extra charge. It is a perfect time to have heirlooms fixed with quadruple silver plating before the holidays are here. Free price list. The Senti-Metal Co., Silver-Plating Div., HG10, 1919 Memory Lane, Columbus, OH 43209.



"NO SMOKING"

We know—you might want to quit smoking but it's difficult. "How to Stop Smoking" teaches you *relaxology*, a surefire way to convince yourself to kick the habit forever. Produced by a surgeon, the method causes no side effects (like overeating). \$4.98 plus 40c post. Anthony Enterprises, HG10, 585 Market St., San Francisco, CA 94105.

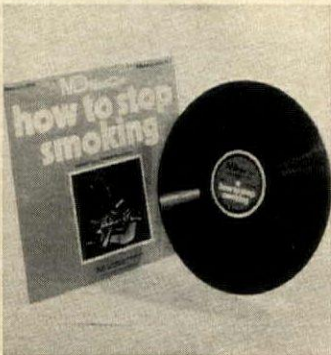

FORMAL FINERY

Sized with White House dinners in mind, a tablecloth in white or natural cotton/dacron, exquisite Sardinian pattern. 63" by 83", 72" round, or 72" by 90" sq. or oval, \$29.95. 72" by 108" sq. or oval, \$44.95. 72" by 126", \$54.95. 72" by 144", \$69.95. Add \$1 post. Catalogue, 55c. Hildegard's, HG10, 597 Farmington Ave., Hartford, CT 06105.



MOODY DOOD

Merry mod man reflects your mood! Feeling blue? His hair hangs low. Happy day? Style the two-tone locks accordingly. Creative neckwars for funsters of all ages. Shaggy synthetic fur in pink/purple, red/black, yellow/orange, pink/red or blue/green. \$1.25 ppd. Catalogue free from Desert House, HG-3, Box 11114, Albuquerque, NM 87112.

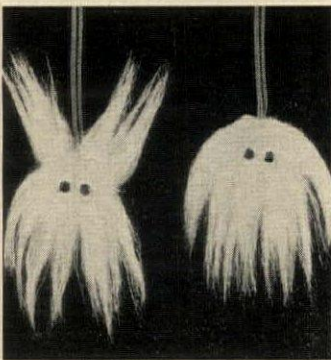

COLOR WALLET PHOTOS
20 FOR ONLY \$2.00 OR 36 BLACK & WHITE \$1.00

Our new equipment gives you amazingly beautiful TWENTY 2 1/2" x 3 1/2" Wallet Photos in vivid COLOR... from your Polaroid color print, color photo (5" x 7" or smaller), negative or slide. A swell gift, or exchange with friends, classmates or relatives. ONLY \$2. (\$6. Value), or 36 Black & White Wallet Photos, Only \$1. Send negative or photo. Your original returned unharmed. FULLY GUARANTEED!

Add 35¢ per order for postage & handling.

ROXANNE STUDIOS, Box 1012, Long Island City, N.Y. 11101 Dept. C-15

FREE BONUS!
One Photo [color or B&W] enclosed in clear plastic.

HIGH TIME CEILING ALARM CLOCK

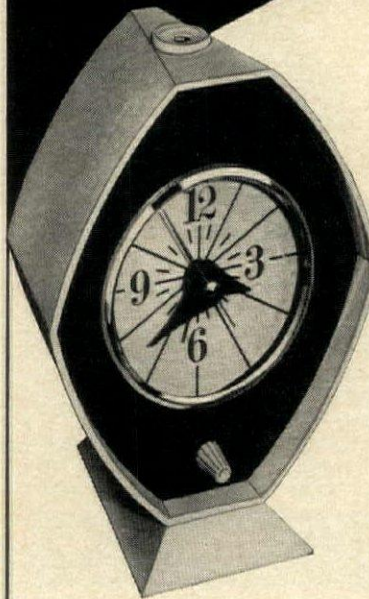

ONLY ELECTRIC UNIT OF ITS KIND

Ho Hum! Don't bother turning on the lights to see what time it is. Look at the ceiling and see it projected in clear, digital numbers. Invisible beam emitted from top of clock shows the time on the ceiling... no night-light glare to interfere with sleep. Only electrical unit of its kind. 7" high 5" wide, with an alarm. One year factory warranty. Truly a gift that will be long remembered. \$29.95 ppd. anywhere in USA.

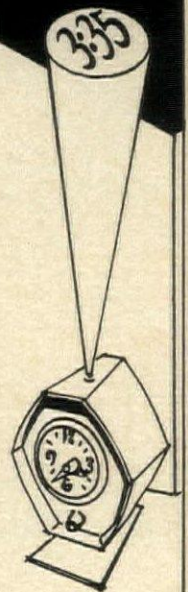

MONEY BACK GUARANTEE

HOUSE OF MINNEL, Dept. 501
Deerpath Road, Batavia, Illinois 60510

Enclosed find \$_____ for _____
Ceiling Alarm Clocks at \$29.95 ppd. Name _____

Ill. Res. add 5% tax. Gift Catalog 25¢ Address _____

SPECIAL DISCOUNT PRICES ON QUANTITY ORDERS City _____

State _____ Zip _____

ADD STRIKING DRAMATIC EFFECT TO ANY DECOR!
IMPORTED TAPESTRY

You'll treasure this magnificent reproduction of a centuries old tapestry, painstakingly woven in the original colors by West German craftsmen. Display this wall hanging with medieval, Spanish, modern or many other types of decor. Figures, banner and plants are strikingly outlined in golden thread to stand out in bold relief from the predominantly red and burgundy background, with navy blue, brown and beige in the lower portion. Ready to hang from any type rod (not included).

48" x 32" **\$79.50** Add \$1.50 for postage.
N.J. res. add 5% Sales Tax

Sorry, no C.O.D.'s. Include check or money order, allow 3 weeks delivery. Same day shipments if you include postal or bank money order.

Lewis Import Mart Dept. HG210, 125 Somerset St. North Plainfield, N. J. 07060

REFERENCE STAND

Now—Enjoy Your Large Reference Editions Without Problems of Handling!

Our superb book stand holds the big books on top, open—for ready reference. Oversize volumes fit comfortably below, ready for use. Handsome enough to enhance the finest library! Beautifully crafted of knotty pine, in honey tone pine or maple, antique pine or walnut finish. 39"H., 23"W., 15"D. (Storage area 12"H.)—\$29.95.

COMPLETE KIT: Unfinished, easy to assemble. Simple instructions. Only \$18.95. Both Postpaid. Add \$1.50 Ea. West of Miss.

Send 25¢ for new 76-pg. color catalog... over 1200 items. Finished and Kit Furniture in Friendly Pine

Include Zip No. Not Sold in Stores Money-Back Guarantee

Field House
Dept. G10-1D
North Conway, N. H. 03860

The One-and-Only DAX® Frame!

The original frameless frame, the one museums use. The one honored by New York Museum of Modern Art! Crystal-clear plastic displays and protects photos, prints, stamps, butterflies, flowers, child's art. Place items on the white back, replace clear frame like a box lid—open any time to rearrange.

Pre-cut holes hang in any position—or it stands alone. Perfection-crafted in U.S.A. of museum-quality materials—that's why imitations can't match it for precise non-warp fit, true image, lifetime beauty!

#6932—Dax Frame, 5x7".....\$3.49 Add 35¢ postage
#6933—Dax Frame, 8x10".....\$5.49 & hdlg.
#6934—Dax Frame, 11x14".....\$7.98

LILIAN VERNON Dept. G01, 500 S. 3rd Ave. Mt. Vernon, N.Y. 10550



ENGLISH LIBRARY CHAIR

This outstanding reproduction, with its nail head trim, is built for a lifetime. It is hand-tufted and covered in top grain leather, which grows more beautiful with use and age. Finish: Light or dark Fruitwood. H 46" W 32" D 34" Price: \$249.50 in Peerless Antique leather. (Add \$20 for Masterpiece leather). Price: Vinyl \$149.50 Shipping charges collect. No C.O.D. SEND 25c FOR OUR NEW CATALOG

Bryan Robeson

Dept. HG-27
Box 757, Hickory, N.C. 28601

THE HORSEHEAD HITCHING POST

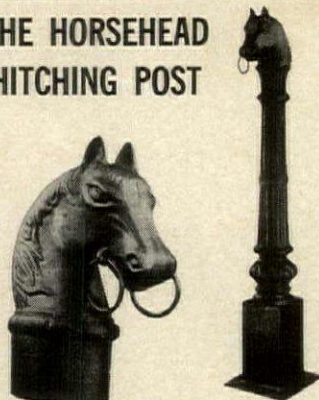

A bit of Americana at its charming best. Both Horsehead and Hitching Post date back to the early 1800's and were used in villages, towns, large cities—in front of cottages and stately mansions. Ideal as driveway markers, at front entrances, on Patios and Terraces. Cast of iron. Finished in satin black. #1510—48" H, \$79.50. #1509—12½" H, \$29.95. No C.O.D. Shipped REA, collect. Catalog of outdoor and indoor furniture and accessories, 35c. Dept. HG6.

The Lakeside House

P. O. Box 486, Wylie, Rock, S. C. 29177

SHOPPING AROUND *early* FOR CHRISTMAS

Get a head start on the holidays. Shop now. Essential for personalized items and made-to-order upholstery, do-it-yourself creations. And you won't have to worry about your gifts arriving after Santa. Happy early shopping!

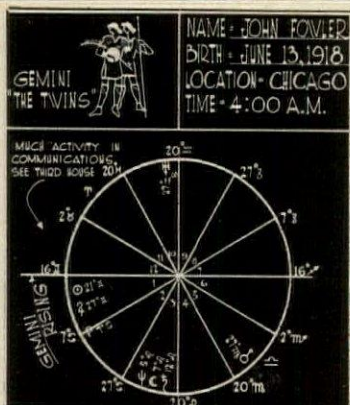

Decorative HOROSCOPE PICTURE

Personalized just for You! Hand-lettered in soft pastels on matte black, 11" X 15" board, unique and beautiful enhances any decor. That something different for someone special.

Print: NAME, DATE & LOCATION OF BIRTH, HOUR (if possible)
\$29.95 Postpaid
Special . . . Two Horoscopes \$54.95
Ga. residences add 3% Sorry no C.O.D.

WOULD YOU BELIEVE
P.O. Box 47887 Atlanta, Georgia 30348

PROTECT YOUR CHECKS



PROTECT-A-CHECK. The most unique check writer ever offered. Gives neat professional appearance to checks. Just dial any amount to \$9,999.99. Prevents alteration. Complete with built-in stamp pad and ink supply. Built to last. Perfect gift for every owner of a checking account. It's small enough for pocket or purse. Fully guaranteed. Calif. add 5% Sales Tax. only **\$5.98**

WE PAY POSTAGE AND HANDLING

EMBER ENTERPRISES

Suite 102
10530 Encino Ave., Granada Hills, CA 91344



CHRISTMAS POINT

A Christmas stocking to needle-point really should be dubbed Christmas point! Kit includes French canvas, 100% wool yarns in traditional red and green or psychedelic colors, design chart, needle, velveteen for back of stocking, instructions. 7" by 15". \$5.95 plus 50c post. Classic Corner, HG10, 12H Water St., Bryn Mawr, PA 19010.

FRAMED GREETINGS

A fantastic idea! Your greeting card becomes a gift! Enclosed in a clear, acrylic frame for photographs! Choice of Birthday, Anniversary, Thanksgiving, Christmas, Season's Greetings, Thank You, Get Well, or New Year's Greetings. 3" w. by 3¼" h. Three for \$5.25 ppd. Extras \$1.50 each. Ursell's Inc., HG10, 3243 Que St., N. W., Washington, DC 20007.

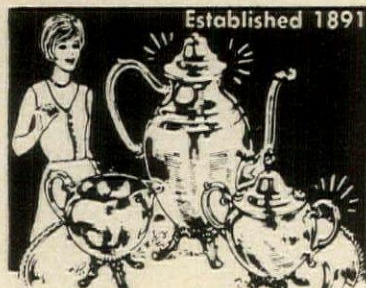

Established 1891

Silver Plating AND REPAIR

NEW BEAUTY FOR OLD SILVER
For more than three-quarters of a century, our craftsmen have restored fine silver to its original beauty. Flawless repairing. Heavy coating of pure silver. Careful polishing and thorough inspection. Replacement of knife blades, mirrors, other parts.

Also: gold, brass plating. Pewter repaired and refinished.

FREE ILLUSTRATED BOOKLET. INCLUDES PRICES.

SIMMONS SILVER PLATING CO., INC.

411K Whitehall Street, S.W.
Atlanta, Georgia 30303

FROM FACTORY TO YOU Puritan Ladder Back



This is the big one with a seat measuring 18½" x 15½". Constructed from smoothly sanded native hardwood, this everlasting styled chair also features a handwoven cord seat.

Ready to finish, \$22.95.

Finished in walnut, maple, or pine, \$25.95.
Colors—green, black, red, white, \$26.95.

Send check or money order—Express collect.

MARION TRAVIS

P. O. Box 292, HG10
Statesville, North Carolina



PAIR OF PRETTIES

That's what you have with these swivel, foam-padded seats. Hardwood frames with 12 hand-rubbed finishes. Beauty Spot is 24" h., 18" dia., seat 19", \$54.50. Powder Puff stool is 19" h., 18" dia., at \$49. Exp. chgs. coll. 40-page catalogue with samples, \$1. Hunt Galleries, Inc., HG10, 2920 No. Center St., Hickory, NC 28601.

GOLFER'S GADGET

Engraved solid steel tool lifts and levels divots, tightens or replaces cleats and flicks dirt off club faces and balls. Tool fits on any key chain or caddy cart to go where the golfer goes. Specify two or three initials. Chrome finish is easy to clean. \$3 ppd. Elgin Engraving Co., HG10, 614 South St., Dundee, IL 60118.



HOLIDAY HOUND

Deck the tree or a special package with a winsome basset. Hand-crafted, hand-painted pooch wears a Santa hat and an Xmas ball on his tail. Superbly crafted of wood and 4" high. \$4.70 ppd. Send \$1 for color catalogue of over 300 whimsical ornaments. Emgee Corp., HG10, 3210 Koa-paka St., Honolulu, HI 96819.



SERENE SET

Hummel ceramic figures. Holy Family, hand-painted \$42; white, \$22. 75c post. Herald angel, color, \$11; white, \$5. 65c post. Nativity color set with 11 figures, no stable, \$145.50, \$1.75 post. With stable, \$165.50, \$3.75 post. With stable and light, \$170.50, \$3.75 postage. Catalogue, 95c. Hildegard's, HG10, 597 Farmington Ave., Hartford, CT 06105.

PICTURE STITCHERY

Stocking-capped Scandinavian boy sets out a lantern for Santa. Basic embroidery stitches create the picture on pattern stamped on deep blue linen. 7½" by 10". Red, green, black and yellow linen yarns, mounting boards, instructions included. Send \$2 for 40-page color catalogue. Skön, GE10, 55 Lambert Lane, New Rochelle, NY 10804.

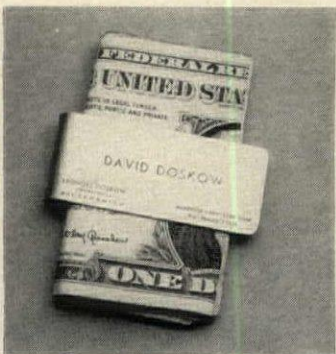

CALLING CARD CLIP

His business card, company trademark, logo or lodge emblem finely etched in miniature on a heavy sterling money clip. Send actual card or design and lettering as it should appear on clip. A distinctive gift for that special man. \$15 ppd. Order from Holiday Gifts, 310-F, 7047 Pecos St., Denver, CO 80221.

CELLARETTE BAR

Why shouldn't a storage unit for spirits and such be a handsome piece of furniture? It is when it's Italian Provincial with a warm cheery veneer from Bryan Robeson! Portable bar with three shelves on concealed casters and locks "after hours." \$159.95. Exp. coll. New catalogue 25c. Bryan Robeson, Dept. HG-30, Box 757, Hickory, NC 28601.



TREASURE TABLE PLUS

Here's a little round hardwood table with its own cloth! Mahogany or fruitwood finish legs. Table with unfinished top, 22" dia., 26" h. Cloth, 72" dia. in crystal, crushed or plain velvet in a choice of 28 colors. Table, \$18; cloth, \$35. Exp. coll. Brochure and swatches, 25c. Dereka Furniture, HG10, Box 2581, Hickory, NC 28601.

Craftsmen in Charm



The "Lazy Daze"

The Lazy Daze invites you to completely relax in luxurious comfort. Reversible, rubber dacron filled back and seat cushions for lasting beauty and restful lounging; fully lined skirt; arm protectors included. Native hardwood frame is skillfully upholstered in various grades of fine fabrics. H. 32", L. 56", Seat D. 43", Seat H. 17". \$149.00 each; Ship. Wt., 75 lbs. Express Charges Collect. No C.O.D. Send \$1.00 for our latest 40-page Furniture Catalogue and Fabric Samples.

Satisfaction Guaranteed or Money Refunded

HUNT GALLERIES, INC.

2920 N. Center St., HG10, Hickory, N. C. 28601

Craftsmen in Charm



VIRGINIA MOUNTAIN CRAFTS

Add Colonial Charm to Your Home!

Some of the authentic reproductions by Virginia Mountain Craftsmen are shown in this bedroom at Rosemont, home of Laura Copenhaver Industries. On the bed is a handsome blue and rose "Lover's Knot" Coverlet. Hand-tied Canopy has Double Diamond Point design. Hand-Hooked Rug is in "Gift of Love" pattern. Curtains with hand-tied fringe. Hand-made quilts. Hand-made furniture includes "Crow's Nest" table, coffee table, candle-stands, chests of drawers.

Many other authentic designs, patterns and colors offered.

Write us for personalized attention.

Send 25c for illustrated booklet.

Laura H. Copenhaver

"ROSEMONT"—MARION, VA. 24354

OWLS

You loved our mushrooms, so here are our OWLS! We offer a set of 4 different owl lithographs by Ebb Pate. These delightful hooters are all on beautiful paper, 8" x 10", and are personally signed by the artist. The owl portfolio makes a heartwarming gift and a cherished wall grouping.

Set of 4—\$5.00 plus 25c post.
Send for our catalog of other delights, 25 cents!

MERRI MAKERS

502 S. Broad Thomasville, Ga. 31792

CHRISTMAS STOCKINGS

"Ready Stuffed"

UNIQUE AND ATTRACTIVE

Two Sizes	Two Prices
10" for ages 0-4	9.95
19" for ages 5-12	19.95

Individually stuffed with appealing, different items, selected for boys and girls of specific age groups. Give exact age and sex when ordering . . . Guaranteed to please!

Order now!
Include postage \$1.25 per stocking.

THE STOCKING SHOP

216 Avery Avenue
Morganton, North Carolina 28655

Grandmother's Clock . . . today

This magnificent lady stands 72" high, and is carefully handcrafted of mahogany, or cherry fruitwood. Also five decorator colors. Shown in two weight-driven movement, with three chime rods. You can select from four different chimes and movements. All works are finest Western German, and are fully checked and warranted for one year.

\$249.00 Express charges collect

Send check or money order. Satisfaction guaranteed.

Send 25c for our detailed new catalog showing 26 different clocks and fine period furniture.

DECORATOR'S SUPPLY

312 Valley Stream Road
Dept. 43, Statesville, N. C. 28677

GIFTS FROM THE SEA

GIANT CLAM SHELL. Unbelievable white. Use for congealed or tossed salads, hors d'oeuvres, nuts, dips—lovely for fruit and flower arrangements. Shell polished, not coated. Surface is resistant to food, alcohol, and cigarette stains. Wash with soap and water. 9¼" X 7" X 3" D. \$7.00 each.

SPECIAL FOR CHRISTMAS
SOLID BRASS CANDLE AND FIRE LIGHTER

A must for all who enjoy candles and fires in the fireplace. No burnt fingers or match debris. Wax taper extends to light. To extinguish pull in. 12" long. Ring for hanging. Prepaid with 5 wax tapers \$4.50
50 taper refills \$1.50.

CORAL. At long last for sale. Magnificent snowy white skeleton of the sea. Use in flower arrangements, aquariums, paper weights, table decorations, or use as object of art mounted on velvet. 5" X 4" X 3¼" H. \$4.50 each.

All items prepaid.

THE CANE PATCH

Kings Highway North Dept. HG9
P.O. Box 1382, Myrtle Beach, S.C. 29577

SHOPPING AROUND Early For XMAS



An assortment of beautifully hand-crafted, wooden Christmas tree ornaments—Admired for their detail—treasured for their humor—collected for their originality.

Color catalog of over 300 items \$1.00

EMQUEE CORP.
3210 Koapaka Street, Honolulu, Hawaii 96819



MOBILE SCULPTURE
Butterfly with Flowers

Unique, entrancing, swaying gracefully in light breeze. Handcrafted of lacquered copper wire, tipped with crystals and colored beads. Stained walnut base, matte gloss finish. Approximate height 23". \$20 postpaid.

ART IN COPPER
575 Woodvine Ave., Metairie, La. 70005

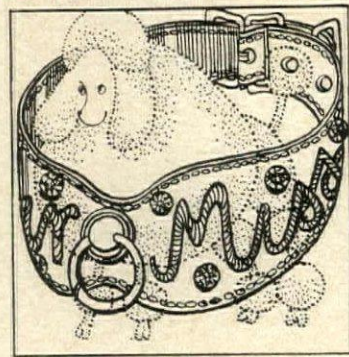

NEEDS NO INTRODUCTION
The well-dressed dog *must* have a velvet covered leather collar with name monogrammed in gold script. Specify name, color and size—up to 10" (S) \$18.95, 10" to 14" (M) \$18.95; over 14" (L) \$22.95. Ppd. Black, gold, white, yellow, green, pink, turquoise, blue, lavender, red. Styles by Athena, HG10, Box 596, Hallandale Beach, FL 33009.

Craftsmen in Charm



The "Hamilton"

Big, handsome and bold enough to invite you to sit down in the lap of luxury. Foam over native hardwood frame; button-tufted back; reversible, zippered, and rubber dacron filled cushion; lined skirt; arm protectors included. Available in various grades of fine upholstery fabrics. H. 31 1/2"; W. 29 1/2"; Seat H. 16 1/2"; Seat D. 19". Ship. Wt., 55 lbs. \$105.50. No C.O.D. Express Charges Collect. Send \$1.00 for our latest 40-page Furniture Catalogue and Fabric Samples.

Satisfaction guaranteed or money refunded

HUNT GALLERIES, INC.
2920 N. Center St., HG10, Hickory, N. C. 28601

Craftsmen in Charm

PLAYHOUSE... OVER 5 FEET TALL



FUN FOR INDOORS OR OUT
Big enough for a jr. size family of four, this luxurious WALK-IN Playhouse is decorated in FOUR GAY COLORS on white. Measures 63" x 48" x 45", has windows on 3 sides. Constructed of reinforced rigid fiber-board, goes together in minutes with exclusive interlocking assembly. Abounds with Play fun. Guaranteed to remain a treasured gift for years.

SPECIALLY PRICED AT \$14.95
SATISFACTION GUARANTEED
Add \$1.50 postage & handling

PEGASUS Dept. HG-10
175 Lauman Lane, Hicksville, N.Y. 11801

PERSIAN PATTERN
Kits—they're the answer to do-it-yourself expertise. Consider a Danish design like "1001 Nights" with design stamped on linen, yarn, beads, mounting plate, needle and instructions. 9" by 23" multi-color on a green background. Sent from Copenhagen. \$16.25 ppd. Two embroidery and one Rya catalogue \$1. Tillalla Inc., HG10, Box 484, NY 10021.

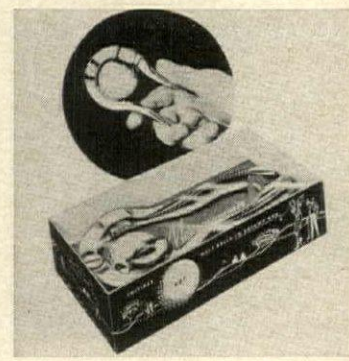
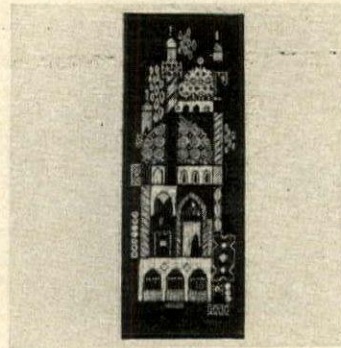

INITIALED GOLF BALLS
Put your initials on your golf balls in just minutes. Monogrammer has strong chrome finish and permanent foil print (no ink), and engraves three snappy blue metallic initials. Remember to include three initials with order, \$6; for 24k gold plate, \$10. Ppd. Gift boxed. Camelot Enterprises, HG10, 151 Schwartz Rd., Lancaster, NY 14086.

BLAST OFF!
Launch your Christmas season into a gay orbit with tree trims from outer space. The Astronaut figurines are 6" high, wear blue space suits and glass bubble headgear—all handblown in Italy. Have yourself a way-out tree. \$2.50 each; a pair for \$4.75. Add 80c postage. Artisan Galleries, HG10, 2100 No. Haskell Ave., Dallas, TX 75204.

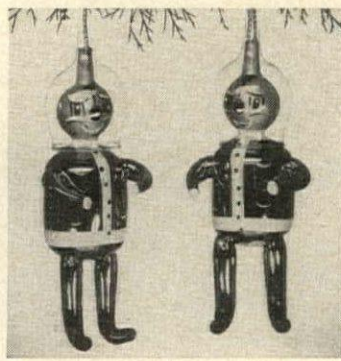

SEND YOUR NEGATIVE FOR A FREE SAMPLE



Photo Christmas Card
COLOR or BLACK & WHITE

Complete with envelopes. Additional cards 16¢ each. Made from your square color negative. From slide add 50¢. From color photo add \$1.50. Size 3 1/2 x 5.

PHOTO CHRISTMAS CARD
COLOR 25 FOR \$3.50 ONLY Add 50¢ Postg. & Handlg.
BLACK & WHITE 25 FOR \$1.00 ONLY Add 50¢ Postg. & Handlg.

Complete with envelopes. Additional cards 5¢ each. Made from your square negative. Add 75¢ if photo is sent. Size 3 1/2 x 5.

Satisfaction guaranteed or money back. No C.O.D.'s. Send check, cash or M.O. Many other designs available. Write for booklet.

PHILIPS FOTO CO. DEPT. HG-1. ELMSFORD, N.Y. 10523

PERSONALIZED CRYSTAL GLASSWARE



Sheer elegance for your bar or table in a magnificent, 42-piece Crystal service for eight, including a 21 oz. snifter-pitcher with stir rod. Each sparkling piece is hand-engraved and satin-etched with initial in distinctive old English lettering. Connoisseurs will appreciate the sheer rims and graceful styling, hallmarks of excellence in fine glassware. Specify Initial.

42 piece set — \$29.95
plus \$4.00 for postage, insurance and handling.

N. Y. State residents include sales tax
Gift catalog FREE on request.

R. M. Reahl, Dept. G-101
325 Whittier Ave., Floral Park, N.Y. 11001



CARVED FRAME CHAIR
Arm chair in Queen Anne manner has velvet upholstery; comes in mahogany, fruitwood or parchment finishes. Back, with diamond tuft, hand pleating or plain. 28" w., 28" d., 35" h., seat h., 18". Oyster, blue, gold or citron velvet. \$115 ea.; \$215 a pair. Exp. coll. Catalogue, 35c. The Lakeside House, HG10, Box 486, White Rock, SC 29177.

FESTIVE PHOTOS
Wonderful Christmas greetings *Christmas Letters*. Photographs of home or family beautifully photo-lithographed on one of 40 Christmas letterheads, cards, or French-fold designs. 100 letters or cards with photo and envelopes, \$20; or without photo, \$16. Ppd. Send 10c for sample. *Christmas Letters*, HG10, 2919-E Pearl, Boulder, CO 80302.



SHOPPING AROUND

HOT POT!

Insta-Hot boils any liquid in just 90 seconds. Double-coated Teflon holds six cups, controls and holds heat from 100 to 225 degrees. Flame red exterior and graduated signs for measuring. Complete with cord, cover, instructions. \$14.95 ppd. New 72-page gift catalogue, 25c. Suburbia, Dept. 304, 366 Wacouta, St. Paul, MN 55101.

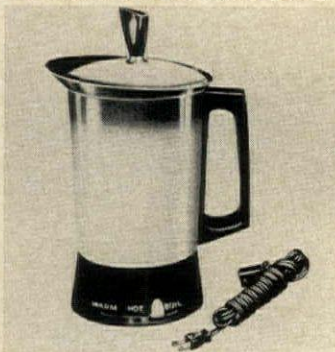

TASSEL TIP

Take a tip from Talbots where fun footwear and fabulous fashions abound. Here the tasseled kidskin shoe that's just right for the longer skirts. Navy with red or green; black with red; red with navy; brown with taupe; navy; black. Sizes 5½-10, N, M. \$17 plus 90c post. Free catalogue. The Talbots, Dept. TF, Hingham, MA 02043.



IN THE MOD MOOD

The vest has come into its own in the past dozen years and a monogrammed one is something else! Scintilla does it in polished acetate satin with brass ball buttons. Olive green or red in jacket sizes 36 to 46. \$16.50; three letter monogram (specify), \$2. Ppd. Scintilla, Dept. G, 4802 No. Broadway, Chicago, IL 60640.



HAND WORK WIZARDRY

Let Martha Klein, a genius at designing unusual mountings and handbag frames, transform your needlepoint, crewel embroidery, bead work or fabric into a special handbag. Free folder with designs and estimates for a handbag, eyeglass case, belt, pillow and luggage straps. Martha Klein, Ltd., HG10, 3785 Broadway, New York, NY 10032.



TYPEWRITER TYPE

Handsome desk for portable typewriter conceals the machine when not in use and comes in contemporary, early American, French or Italian provincial, oriental styles and finishes. 21" by 22" by 26½" h. \$169.95 and up. Same styles for standard machines. Free brochure. Little Home Office, HG10, 1566 Fisk Rd., Grand Rapids, MI 49506.



RETRACTING BRUSH

Pet brush massages, brushes and cleans itself thanks to its 120 retractable bristles. It works with a simple twist to extend bristles, another twist retracts them. Frequent use gives your pet a smooth, glossy and healthy coat. \$1 plus 15c post. Anthony Enterprises, HG10, 585 Market St., San Francisco, CA 94105.

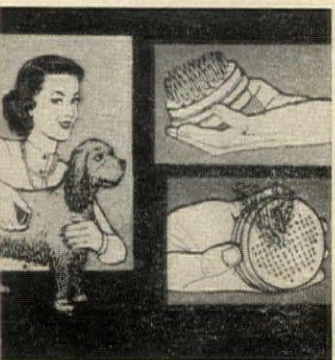

The
DUTCH COOKIE PLATE

in Green Strathmore Pattern
made by famous English Pottery — Mason's
of Stoke-on-Trent, England . . .
and
our 100 page catalog of
"Timeless Furniture Made by Forslund"
Both for \$5.00 Postpaid. Plate size 9" x 11".

Carl Forslund (Father and Three Sons)
DEPT. H.G., GRAND RAPIDS, MICH. 49502

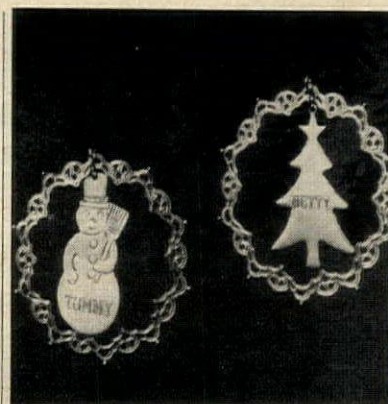

TO START A WARM FAMILY TRADITION . . .
Personalized Tree Twinkles!

\$1.00 each . . . 3 for \$2.75

Christmas time is family time—and what a gala part of the tree-trimming when everyone hangs his own engraved twinkle! Wafer-thin metal, Gold plated to dance with highlights—snowman and tree swing in 2¼" filigree wreaths. Best of all, they are unbreakable, so even the littlest angel can join in!

#1193—Snowman Twinkle } \$1.00 each
#1192—Tree Twinkle } 3 for \$2.75

PRINT names, add 25c post. & hdlg.

Dept. G01,
560 S. 3rd Ave.
LILIAN VERNON, Mt. Vernon, N.Y. 10550

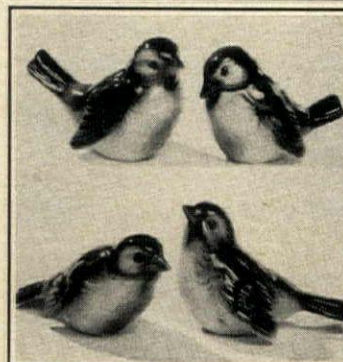

Snowbird Quartet

From the factory that makes the famous "Hummel" figurines. Charming little birds are lifelike and appealing in their alert, pert poses, seem to have just alighted on your home windowsill, table or mantel. In true color glazed ceramic and about 4"; trade-marked. Set of 4, each a different pose.

No. 6458 1 Set, \$8.98 ppd.

Write for FREE catalog of unusual items.

Please, your zip code is required.

Downs DEPT. 1410-B
EVANSTON, ILL. 60204

Yo-Yo Anyone?

For the person who has everything! This sterling silver yo-yo is the standard size & comes ready to use. Space for monogramming if you wish. **\$10.00 each, 2 for \$19.50.** Add 75c for postage and insurance. Start your holiday shopping early from

E. STEPHEN HEIN, INC.
(formerly The Villager)
Gardenside Plaza • Lexington, Ky. 40504

Lead Crystal Trees
FROM FRANCE

Glorious in a bower of evergreens on your dining table to sparkle and shimmer. Superb—the finest crystal from France. Be individual, create the unmatched. 5¼" H \$15.00, 8¾" H \$25.00, 10¾" H \$37.50, 12¾" H (not shown) \$49.95. Add \$1.25 postage, any tree size.

Quality and Integrity
Catalog . . . 25c

THE GIFT TREE
Box 55, Dept. G10-1
Kensington, Md. 20795

PLAN NOW FOR HOLIDAY DECORATION

PINE CONE NOVELTIES and DECORATIONS

This brand new book—just off the press—illustrates 40 Thanksgiving and Christmas season decorating projects using simple pine cones in your own ingenious way. You'll get nothing but praise for such novel arrangements as wreaths, centerpieces, favors, place cards, scenes, ornaments, snowmen, pixies, fireplace arrangements, window decorations, etc.—Send **\$1.20** today for your book of versatile suggestions.

MARDON HOUSE
BOX 1972, DEPT. HG-10, BLASDELL, NY 14219

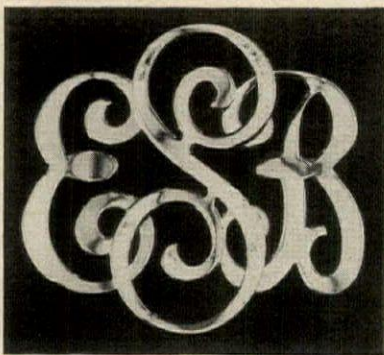

Beautiful 3 Initial

24 KT GOLD PLATED PIN

A gift to be proud of for years to come. Personally yours. For family and friends. Three initials in heirloom 24 KT gold-plated finish. Safety catch. Adds glamour to your pantsuit, dress, scarf or purse. Custom made. Immediate shipment first class mail prepaid. Print plainly FIRST, MIDDLE, LAST initial. Circle last initial. Last initial mounted in center. \$6 EACH 2 FOR \$11.50, 3 FOR \$16.50. SEND CHECK OR MONEY ORDER, OR CHARGE BANK AMERICARD OR MASTERCARD. DEPT. HG10.

CREST HOUSE

1013 PORTAGE TRAIL, CUYAHOGA FALLS, OHIO 44223

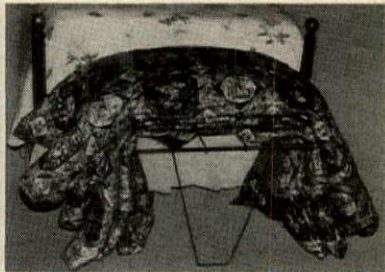

BED-SPREAD CADDY SAVES TIME, TUGGING

Simplify your bed-making . . . and stop nightly tugging or folding away heavy spread. Just pull hidden caddy from beneath mattress and lay bed-spread across, ready for easy make-up in the morning. Legs swing automatically into position. Handsome, gold-flecked caddy glides effortlessly out of sight during day. Ideal for Hollywood beds or low foot-boards. For king-sized or double beds, order two.

\$7.98 two for \$14.98, plus 90c postage

GARRETT'S

P.O. Box 8415-58 Dallas, Texas 75205

SHOPPING AROUND

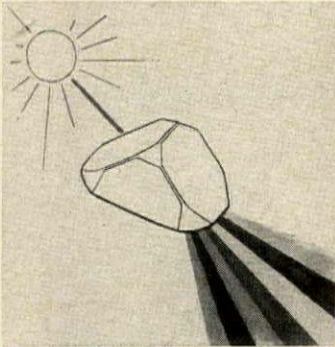

GALA SPECTRUM

Can be seen with prism made of optical glass that bends light rays of shorter wavelength at a sharper angle than those of longer wavelength. Fine introduction to theory of electromagnetic waves, whole science of color. \$1.29 plus 15c post. Anthony Enterprises, HG10, 585 Market St., San Francisco, CA 94105.

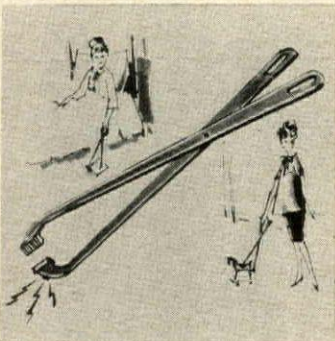

GO TO NEW LENGTHS

Extend your reach by 27" and discover the easy way to get a can of anchovies from the top shelf without a ladder. Smooth birch E-Z Reach has non-slip ends and magnetic tip to get a good grip on elusive pins, clips — saves stooping. Gives independence to an invalid, too. \$4.29 ppd. Better Sleep, HG10, New Providence, NJ 07974.

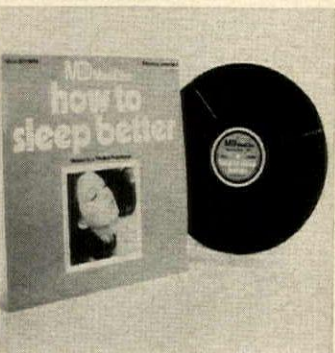

FOR SOME SHUT-EYE

Insomnia haunting your nights? Dash the wide-eyed monster with a helper better than the sandman. "How to Sleep Better" teaches you how to relax. A common sense approach to encouraging sleep, the record's produced under medical supervision. \$4.98 plus 40c post. Anthony Enterprises, HG10, 585 Market St., San Francisco, CA 94105.



PRE-COOKED GOURMET

Just put succulent boneless stuffed chicken breasts in the oven for 35 min. A La Kiev stuffed with seasoned butter, Cordon Bleu with ham and cheese. A La Regal is wild rice and mushrooms, A La Piquant is cheese and mushrooms. 12 eight-oz. portions \$28 ppd. Free catalogue. Pfaelzer, LEM, 4501 W. District Blvd., Chicago, IL 60632.



NO MORE SUDS

In the eyes, that is! Foam sponge shower goggles with clear plastic lenses permit shower takers to watch while eyes are protected from both water and soap. A self-adjusting elastic strap secures goggles so one size fits all comfortably. \$1 plus 15c post. Anthony Enterprises, HG10, 585 Market St., San Francisco, CA 94105.



Wedgwood Mayflower Plate

Collector's plate to mark the 350th anniversary of the landing of the Pilgrims at Plymouth Rock; blue jasper with white bas-relief of ship, holly leaf border. "Mayflower 1620-1970" embossed in blue. 4 1/2", beautifully made and worthy of its famous maker. From England, limited quantity. An heirloom of tomorrow!

Order No. 7590.....\$5.95 ppd.

Write for FREE catalog of unusual items.

Please, your zip code is required.
Downs DEPT. 1410-A
EVANSTON, ILL. 60204

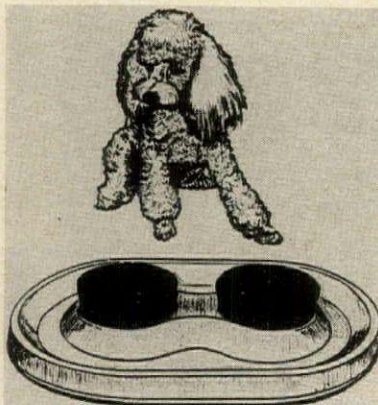

LESS MESS PET FEEDER

Put an end to cleaning the spilled mess after your pet's meals. The sanitary white 12 x 3 x 20" tray traps the spillage, keeps the food and liquid off the floor. Underneath are rubber suction cups that firmly anchor the tough plastic tray to any smooth surface to keep from sliding. Colorful machine washable bowls fit snugly to prevent tipping. Specify bowl colors in red, yellow, poodle pink or green.

\$3.49 add 85c mailing each.

HOLLY HOUSE

9924 Edgecove Dallas, Tex. 75238

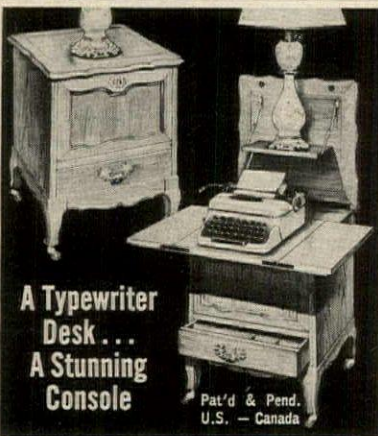

A Typewriter Desk... A Stunning Console

Pat'd & Pend. U.S. - Canada

Converts Instantly!

Your Typewriter — Manual or Electric — and Writing materials concealed in a Grand Award winning piece of fine Grand Rapids furniture, designed especially for the home. 21" x 22" x 26 1/2" high.

French or Italian Provincial — Early American — Far Eastern — Contemporary. Spring operated. From 169.95 up. Also same styles for standard typewriters. Matching Files. Write for free Brochure.

little home office®
1566 Fisk Rd. Grand Rapids, Mich. 49506

This Year Send YULECARDS®

THE ORIGINAL PHOTO CHRISTMAS CARD
Greatest style selection anywhere

BLACK & WHITE with envelopes

20 \$1 FOR plus 35¢ shipping

FULL COLOR with envelopes

20 \$3 FOR plus 35¢ shipping



SATISFACTION GUARANTEED
Send color negative or slide for color cards, or black & white negative for black & white cards.

FREE SAMPLE CHRISTMAS CARD

Send negative or slide for deluxe custom sample card. (Enclose 10¢ shipping.) Free folder sent with sample.

YULECARDS® DIV. OF MAIL-N-SAVE®
BOX 310, DEPT. M-11, QUINCY, MASS. 02169

adjustable Hi-Low T.V. POLE STAND

For the bedroom, living room, kitchen, family room, porch . . . no matter where you're viewing this smart new T.V. Pole Stand holds your portable at the level and place best suited for comfort . . . without taking up valuable floor or table-top space. Takes any width, up to 14" front to back, up to 17" top to bottom. Easy to install and move. Spring decorator pole has spring tension rod at top to adjust to your ceiling height, can be set up in Hi or Low position. Hi position is great for reclining watchers. Made in USA.

\$12.95 Ppd.

We ship in 24 hrs.

Write for FREE catalog of gifts.

Holiday Gifts Dept. 310-A
7047 Pecos St., Denver, Colorado 80221

SHOPPING AROUND

RANCH RIG

Crisp, clear lines of corduroy are just what's needed to make the perfect casual dress. This one has authentic ranch styling with snap front, gored skirt, stirrup belt. Gold, liberty blue, geranium pink, moss green, desert tan. Sizes 10-20, 12½-24½, 38-44. \$18 plus 60c post. Vicki Wayne, 610-HOC So. Country Club Rd., Tucson, AZ 85716.



MIGHTY MINIS

One dozen miniature plastic clothespins are just what a gal needs to hang up her hosiery and lingerie at home or at a vacation spot. The little pins are 1⅞" long and are easy to slip in a suitcase pocket or a handy clear plastic bag. \$1 plus 15c post. Anthony Enterprises, HG10, 585 Market St., San Francisco, CA 94105.

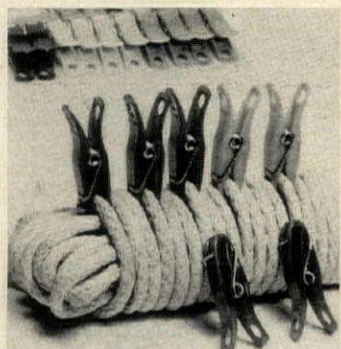

LAZY LIBRARY

Richly-grained pine coffee table swivels like a lazy Suzan and holds books on a 12½" high shelf. 36" dia. table holds 100 books, unfinished, \$30; finished in honey or antique pine, maple, walnut, \$44.95. 24" dia., unfinished, \$19.95; finished, \$31.50. Exp. chgs. coll. Yield House, HG10, North Conway, NH 03860.

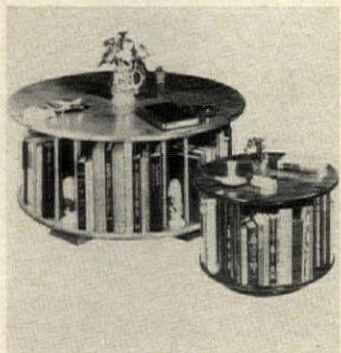

FAMILY BASKET

Wicker basket bears an apple tree with the names of all the family hanging as fruit from its branches. 10" by 6½" by 6" with lined interior, a green felt bow. Show it off shopping or family reunions with justifiable family pride. Send first names for apples. \$30 ppd. Plumlea Peddler, HG10, Box 22232, Lyndon, KY 40222.



CLEAN SLEEVES

A boon to all cherishers of 3" by 5" recipe file cards are see-through plastic sleeves. A wipe with a damp cloth eliminates gravy stains, frosting fingermarks and such disfigurements to which all enthusiastic recipe followers seem prone. One pack of 100 sleeves, \$1 ppd. Miles Kimball, 100 Bond St., Oshkosh, WI 54901.



CHAIR CANING KITS

Now anyone can restore his favorite antique and heirloom chairs easily and inexpensively with a NEWELL CANING KIT. Tools, natural cane, and "easy-to-follow" instructions, all postpaid for only \$2.50. Illinois residents, please add 5% sales tax.

(Extra cane \$1.25 chair-lot.)
THE NEWELL WORKSHOP
(Dept. S-4), #128 Drawer
HINSDALE, ILLINOIS 60521



Trim-A-Chin to look younger!



Tightens sagging tissues of lower face in just 14 days-or money back!

Why let drooping jowls make you look older than your years? Now, at last, there's a doctor-designed program guaranteed to improve the appearance of your chin in only two weeks—or it costs you nothing! Trim-A-Chin(TM) is easy, pleasant, effective for both men and women. Only two simple steps help tighten sagging tissues of lower face, aid muscle tone, achieve the smoother chin and jawline contours so vital to a youthful-looking face.

See Improvement in 14 Days

First, massage special Larry Mathews Lube Cream onto key areas, using firming "finger-magic" technique as outlined in instructions. Then slip on the comfortable, soft latex Trim-A-Chin facial belt. Wear it only one hour while doing housework, reading, watching TV—anything. Repeat only three times a week. No vibrators, no itchy astringents, no costly office visits. In just 14 days, see your

chin and jowls beautifully improved—or return program for money back without question. You simply can't lose! Send today for complete Trim-A-Chin home program . . . only \$9.99 plus 75 cents for shipping and handling.

MAIL NO-RISK COUPON TODAY!

Jay Norris Corp., Dept. QE-26,
31 Hanse Ave., Freeport, N.Y. 11520
Please rush me . . . TRIM-A-CHIN(S)
@ \$9.99 plus 75c each to cover postage
and handling. N.Y. residents add sales tax.
Enclosed is () check or () money
order. (No C.O.D.'s)

I understand that, if not fully satisfied, I may return the Trim-A-Chin within 30 days for full refund of purchase price.

Name.....
(please print)

Address.....

City.....

State..... Zip.....



31 Hanse Ave., Dept. QE-26, Freeport, N.Y. 11520

BALL-FRINED CURTAINS COLONIAL STYLE!

Classic Colonial curtains like those made by thrifty New England housewives in the days of our early settlers. Made of natural unbleached or snowy white bleached MUSLIN, they're trimmed with fluffy chenille BALL FRINGE and they're 70" wide to the pair.

24" Long	... \$3.50
30" Long	... 3.50
36" Long	... 4.00
45" Long	... 4.50
54" Long	... 5.00
63" Long	... 5.00
72" Long	... 5.50
Matching Valance	
11" x 68"	... 2.25

VERSATILE—hang as Tier upon Tier, Tier and Valance or use two pairs Cottage Style (as illustrated) or one pair full length tied back. Two matching tie-back pieces included with EVERY PAIR.
Order style "ESSEX"
Avoid delay: specify White or Natural
Add 75c postage to each order.
OLD COLONY CURTAINS, HG-102, Box 787, Westfield, N.J. 07090
Money back guarantee. Send check or Money Order. No COD's.
Delivery in N.J. add 5% Sales Tax

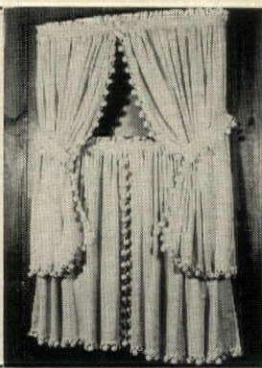

Rococo CONSOLE SET **\$3.98**
Add 85c Postage

A stunning set for center hall, living room or dining room! Magnificent provincial styling in antique gold finish. Mirror 14" x 9½", shelf 10" x 7". An exceptional value!

MONEY BACK IF NOT DELIGHTED
Dept. 6201
Plymouth Meeting, Pa. 19462

Harriet Carter



CHIPPENDALE \$79.95

A new dimension to gracious living. Made of the finest Yugoslavian beech, this attractive solid frame chair will give you pleasure for years to come. Caned seat. Side chair \$69.95. Finished both chairs add \$25. Exp. chgs. Col. No COD 128 page catalog \$1.50.

ARTISTIC FRAME INT. LTD.
407-13 East 91st Street, New York, N. Y. 10028

SHOPPING AROUND

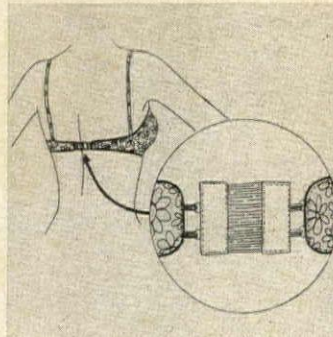

E-X-T-E-N-S-I-O-N

Bra extender enlarges the too-small bra or makes an in-between size fit properly. No sewing required. Hook to both ends of bra and find out how much easier it is to play tennis, golf or garden with a good-fitting bra. Specify two or three hooks. Two for \$1 plus 15c post. Anthony Enterprises, HG10, 585 Market St., San Francisco, CA 94105.



TOPS IN TOGS

Best overalls over all are these by Oshkosh B'Gosh, a company famous for its adult work togs. They put the same wearability into these play ones. Children outgrow them before they outwear them! Hickory-stripped Sanforized denim; rustproof grippers, stout stitching, 1, 2, 3, 4, 5, 6 and 8. \$5.95 ppd. Miles Kimball, 100 Bond St., Oshkosh, WI 54901.



A WINNING AWARD

For gifts, gags, sports and spoofs, here's a plaque you "engrave" yourself. Any ballpoint pen transmits your jovial message onto metal. Try some personalized prose or poetry for a special anniversary. Useful for schools and clubs, too. \$1.98 plus 20c post. Order #162 from Anthony Enterprises, HG10, 585 Market St., San Francisco, CA 94105.



A BARN BUILT BY YOU

Attractive little red barn makes the perfect set-up for a work shop, play house, motorcycle garage, dog kennel. Of 1/2-inch exterior plywood; mounted on skids. Step-by-step plans for 8' by 12' by 9' h. with 4' sliding door. Also a 6' by 8' with Dutch doors. \$2.50 ea., both \$4. Ppd. Hammond Barns, HG10, Box 39027, Indianapolis, IN 46239.



COIFFURE PROTECTOR

Polyfoam band wraps around head to protect locks in the shower, tub or at the pool. Its smooth fit makes it easy to adjust and seals super tight. Water can't seep through. Perfect for gals and long-haired guys. \$1 plus 15c post. Anthony Enterprises, HG10, 585 Market St., San Francisco, CA 94105.

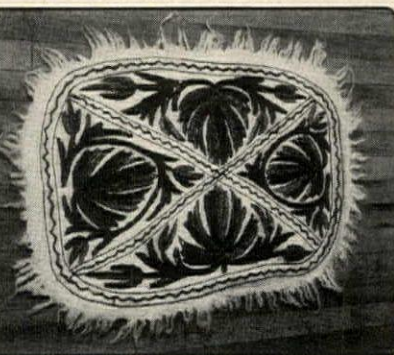

FROM INDIA

H5000 NAMDHA RUG, raw felt rug from Kashmir, 77% cotton and 23% wool. Available in varied patterns of crewel embroidery. 21" x 33".—\$5.75 PPD.

Our latest brochure, including our complete Fall-Winter line of hand-crafted clothes, gifts, books, foods, and crafts.—25c

SPECTRUM-INDIA, INC.
DEPARTMENT HG-10
P.O. BOX 489, PROVIDENCE, R.I. 02901

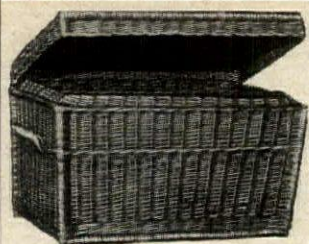

WICKER WONDERLAND

WILLOW CHESTS—Decorative storage for clothes, toys, etc. Samson strong with easy to tote handles. Finished in its own natural rich color.
20" long x 14" x 14" \$11.95 plus \$1.00 postage
24" long x 16" x 16" \$13.95 plus \$1.75 postage
28" long x 17" x 17" \$16.95 plus \$2.25 postage
30" long x 18" x 18" \$18.95 plus \$2.75 postage



LOTUS LAMP—Beautifully hand woven of natural rattan. Completely wired with on/off switch. 9 ft. rattan chain & bracket. Shade is 10" dia. x 9". \$9.95 postpaid. Painted add \$2.00. Use up to 100 watt bulb.

HANDWOVEN WILLOW OTTOMAN—Imported from Europe, is marvelous for resting weary feet or for extra seating. Seat will support a 300 pounder. 24" dia., 14" high. \$11.95 plus \$2.00 postage. Corduroy cushion 13" dia., to fit on seat. \$2.95 (gold, avocado, black or tangerine).

WILLOW ON THE WALL—As versatile as it is attractive! Use it in so many ways in the kitchen, bath or foyer. Hand-woven, 3 tier shelf stands alone or hangs on wall. 18" x 6" x 20" high. \$8.95 plus \$1.00 postage. Painted add \$2.00.

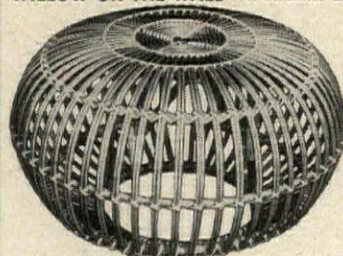

Wicker in House and Garden Colors—Professionally spray-painted in: Pineapple Yellow, Parrot Green, Space Blue, Azalea, Bittersweet, Black or White.

Send 25c for catalog

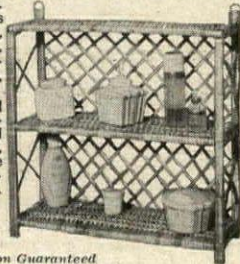

Satisfaction Guaranteed
N.J. Res. add 5% sales tax

VISIT OUR WAREHOUSE SHOWROOM

89 W. Main St., Dept. HG10, Rockaway, N.J. 07866

Fran's Basket House

Butcher Block



34" high work table
36" x 24", \$89.50
48" x 24", \$99.50
60" x 30", \$129.50
or choose 30" dining height table at same prices.
Locking Shepherd Casters, \$20.00 additional

Two-inch thick maple butcher block top, durable bench-construction frame. Sent express collect. In Illinois, add applicable taxes. Send check or money order, no C.O.D.'s please.

For complete catalog of exciting butcher block furniture, send 50¢ to:

butcher block & more

The Schoenheit Company
Dept. 101A, 1600 S. Clinton, Chicago 60616

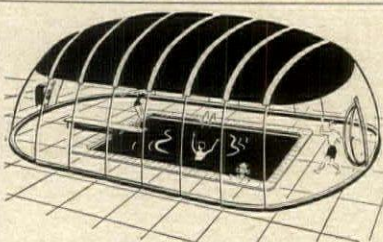

SWIMHUT

Enjoy your pool year 'round in the new space-age enclosure. Solar-heated by day, holds in and utilizes pool heat by night. Swim in real comfort.

Patented water border perimeter seals airtite to pool deck; filtered fresh air within keeps pool sparkling, keeps out leaves, wind, dirt, animals and insects.

Vinyl top appears as stained glass roof, with window clear sides, nylon stabilizers. Durable and lightweight, can be quickly erected or removed as desired by home owner. Low cost is fractional of permanent structures. Swimhut will repay in pool pleasure and care.

Free brochure on request.

AQUAGARD POOL COVERS

2801 SAN FERNANDO RD.
LOS ANGELES, CALIF. 90065



The Original TWIN BED BRIDGE with patented square rib

Makes a Comfortable King-Size Bed out of Twins!

- Fills space between beds.
- Made of soft polyurethane foam.
- Fits any size twin beds.
- Uses standard size sheets.
- Rolls up for easy storage.

We pay all postage \$7.95
Satisfaction Guarantee

TONI STERN

HG-10, 54 W. So. Orange Ave.
South Orange, N.J. 07079

PROVINCIAL SWITCHPLATES

Switch to beauty in your home with little cost with our golden brass-plated switchplates. Non-tarnish finish, screws included. Also in antique white.

SINGLE—3" x 5"	\$1.00 each
3 FOR \$2.95	
DOUBLE—4 1/2" x 5"	\$1.50 each
3 FOR \$3.95	
TWIN OUTLET—3" x 5"	\$1.50 each
TRIPLE—6" x 5"	\$2.95 each
COMBINATION—5" x 5"	\$1.95 each
DOOR KNOB w/spindle & rosette	\$1.95 each

PLUS 45¢ POSTAGE & HANDLING
Pa. Res. Add 6% Sales Tax. Sorry No COD's
THE ADDED TOUCH
12-H Water St., Bryn Mawr, Pa. 19010

SHOPPING AROUND

HOW TO WIN FRIENDS

Remember their names! At your next party, write name and choice of beverage your guests are drinking on these labels that stick to glass or plastic. Makes a great impression to know you haven't forgotten. Ideal hostess gift idea, too. Set of 50 for \$1; three sets for \$2.68. Add 15c post. Handy Gifts, HG10, Culver City, CA 90231.

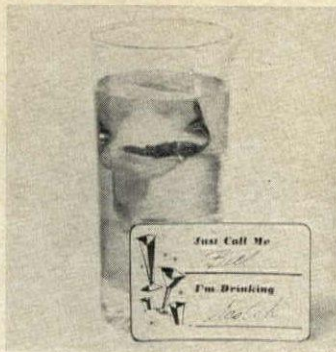

PROTECTION!

Non-allergenic foam fleece mask slips over mouth and nose to protect from sick room germs, paint, cleaning fluids or garden sprays. One size fits all and is washable and reusable. Particularly good for paint spraying or paint removal. \$1.29 each plus 15c post. Anthony Enterprises, HG10, 585 Market St., San Francisco, CA 94105.



SPORTIN' LIFE

The sporting man in a lady's life will bless her forever if she orders him a head-hugging pigskin suede cap. Trouble is, it will probably last and last! For driving, hunting, golf, gardening. Lined cap, treated to withstand weather, in green or brown. 6 3/4 to 7 3/8 (send head size) \$4.95 ppd. Deer-skin Trading Post, HG10, 119 Foster St., Peabody, MA 01960.



HIDE-AWAY

Now you see it, now you don't—under-cabinet trolley attaches easily to cabinet and door; waste can moves forward when door opens, back when door closes. Attaches in minutes to a right or left hand door. Honey tone pine stain finish; 16" h., 12" w. Waste can not included. \$6.50 ppd. Yield House, HG10, North Conway, NH 03860.



PRESIDENTIAL PLAY

This is certainly the year for candidates for President of the United States and Nixon's the man to beat. Board game with "money," dice, candidate cards is sure to guarantee big shake-ups in the presidential lineup. For two to eight players. \$7 plus 75c post. Joan Cook, HG10, 1241 N.E. 8th Ave., Ft. Lauderdale, FL 33304.

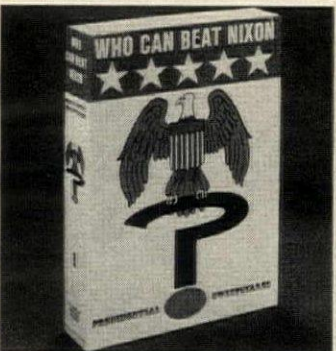

PERFECT PRESSING WITH IRON-ALL

To simplify all your pressing needs, just snap this revolutionary, new attachment onto any iron, steam or dry, and forget about dampening or the old fashioned press cloth. All fabrics, even the most delicate, can now be pressed on the right side, using only the one temperature setting between cotton and wool. Made of Dupont's sturdy, lightweight, aerospace material, Iron-All's high heat resistance enables you to iron safely over buttons and zippers and is ideal for hems, pleats, men's suits, even your finest needlework. You'll iron everything faster, safer, easier with Iron-All. \$3.75 ppd.

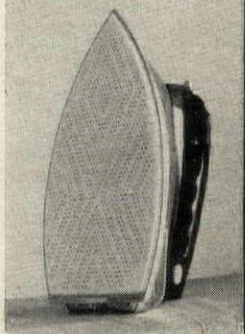

Aquarius Enterprises

BOX 76849
DEPT. HG-10
LOS ANGELES
CALIF. 90005

Calif. res.
add 5%
sales tax

LYNCHBURG
HARDWARE & GENERAL STORE
© 1971
Box 239-F, Lynchburg, Tenn. 37352

Jack Daniel's Old Wood Clock
These clocks are made out of old bar wood the Jack Daniel's people bought up when some old mule barns were torn down around here to make room for the Tims Ford Dam. There's even an old-time Jack Daniel's design painted onto the wood. It'll run for a whole year on one "C" size flashlight battery. This clock is \$20. Please add \$1.00 for postage and handling.

Amfanning

Send check, money order,
Bank Americard or Master Charge,
including all numbers and signature.
(Tennessee residents add 3% sales tax).
For a catalog full of old Tennessee items,
send 25¢ to above address.

FABULOUS FURS BY THE YARD
54" wide
Looks like the real thing

Leopard	\$5.95 yd.	Pony Black	\$8.00 yd.
Tiger	5.95 yd.	Pony Brown	8.00 yd.
Zebra	5.95 yd.	Polar White	12.00 yd.
Giraffe	5.95 yd.	Polar Black	12.00 yd.
Wildcat	5.95 yd.	Bengal	5.95 yd.

SHIPPING PPD.
Perfect for bedspreads, throws, coats, vests, ski parkas, throw pillows etc.

**WILL NOT SHED
DRY CLEAN**

Fur is the latest thing with home decorators and clothing designers.
For complete line of samples send \$1.00 to
THOMAS BURKE, INC.
HG10 1945 Palmer Ave.
Larchmont, New York 10538
Visit our store for dress, drapery and upholstery fabrics.

**Latest eye-glass fashion:
Jewelled Folding Frames
with MAGNIFYING LENSES**

Very clever, very fashionable! "Contessa" full-frame magnifying glasses fold up to 3" x 1 1/4". Fit handily into a small evening bag or clutch purse. Quality optically ground lenses make fine print look big, bring close details out sharp and clear. Beautiful jewelled frames are so delicately feminine. For those over 40 without eye disease or astigmatism who simply need magnifying lenses. Or, your own prescription can replace the magnifying lenses in these magnificent folding frames. Only \$9.98 plus 45c postage and handling. Silk brocade carrying case included. State age. Nel-King Products • Dept. HG-101GF
811 Wyandotte St., Kansas City, Mo. 64105

31 DECORATOR COLORS
48" wide
In a heavy 100% cotton tweed

Preshrunk, yarn dyed, vat colors. The ideal all around fabric for slipcovers, draperies, bedspreads, pillows, etc. Washable or dry cleanable. Treated with "Permel-Plus" for STAIN RESISTANCE.
\$3.50 a yard. Send \$1 for a complete sample book.

All orders shipped postpaid
THOMAS BURKE, INC. HG10
1945 Palmer Ave., Larchmont, New York 10538
Visit our store for dress, drapery and upholstery fabrics.

LUCITE FRAMES
simple • handsome • self-standing

size	postpaid
5" x 7"	\$2.00
8" x 10"	\$4.00
11" x 14"	\$6.00

specify vertical or horizontal
Sam Milstein • Photographer
mm 852 Lake Ave.
Clark, New Jersey 07066

The sheer elegance of
TERGAL®
Imported from France

25 bright decorator colors in this beautiful sheer polyester. For every window & color scheme. 47 inches wide—washable—drip dry.
Only \$2.50 yard.
Shipping cost paid
Send \$1.00 for your complete color range to
THOMAS BURKE, INC.
HG10, 1945 Palmer Ave., Larchmont, N.Y. 10538

Professional Wood Finishers HATE US... For Telling Their Secrets!

It's true that years ago getting a deep, tough finish that brought out the vibrant feeling of living wood from walnut, oak, pecan or any of the cabinet-maker's fine woods, was indeed a "secret art." Professional finishers had "secret formulas" for oils, that gave results you see in pieces hundreds of years old. And to get that "hand rubbed" look, they used lots of something we don't have much of today—time.

Today even the professional doesn't have time... he uses Tru-Oil® by Birchwood Casey, a modern blending of linseed and other natural vegetable oils designed to be fast drying. Tru-Oil can be used on stained or unstained, old or new wood, to fill the grain—without blurring—and seal out moisture. It will not cloud, bleed, become tacky or yellow with age, and Tru-Oil does not scratch white.

And best of all, Tru-Oil is easy to use—no separate filler, no "dewhiskering." Each coat dries in 60 to 90 minutes... not 3 to 4 days.

We developed Tru-Oil for professionals, but we'd like you to try it on the table or chair you're finishing or refinishing... at an introductory price of only \$2.95 (regular price is \$3.50) for an 8 oz. can. That's enough to finish an average table or desk. Just fill out the coupon below and send it with your check or money order to:

BIRCHWOOD CASEY Dept. 113
7900 Fuller Road, Eden Prairie, Minn. 55343
(Minnesota residents add applicable tax)

Name _____ (please print)
Address _____
City _____ State _____ Zip _____

Enclosed is \$2.95 for 8 oz. can of Tru-Oil (postpaid). I'd like to see for myself how easy it is to get professional results with the professional help of Birchwood Casey.



(money back guarantee, of course)

BIRCHWOOD CASEY Dept. 113 • 7900 Fuller Road, Eden Prairie, Minn. 55343

SHOPPING AROUND

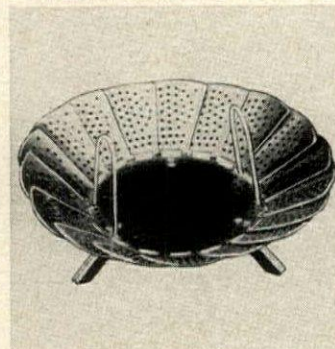

FRENCH FRESHNESS
Collapsible fan-out steam basket from France turns any pot into a double-boiler. It helps retention of vitamins and minerals in fresh vegetables and keeps fresh flavor as well. Two handles for lifting in and out. Collapsible for easy storage. 5½" dia. \$2.95 ppd. Colonial Gardens, HGE10, 270 W. Merrick Rd., Valley Stream, NY 11582.



STRAP SAFETY
Lingerie guard keeps straps together and on your shoulder. Pin fastens to dress or blouse, holds straps securely. No slipping! Order several pairs so you won't have to do a switch each morning. Two pairs are just \$1 plus 15c postage. Write Anthony Enterprises, HG10, 585 Market St., San Francisco, CA 94105.



PUP-POOSE
Pets travel in style with the new tote approach. Shoulder strap means owners of smaller breeds have hands free to cope with fares and such. Bag, hood in orlon pile trimmed in simulated snakeskin. Pup-Poose runs \$5.98 plus \$1 post. Free catalogue of pet items. Du-Say's, Dept. PHG10, P.O. Box 24407, New Orleans, LA 70124.



DON'T WORRY. HE WILL
If you know someone who is a chronic worrier, give him a Worry Bird. Just the sight of that lugubrious face, orange ruff and grotesque feet rates a chuckle even before you read his message. \$1.98 plus 25c postage. Order from Anthony Enterprises, HG10, 585 Market St., San Francisco, CA 94105.



TIME THIEF
Is your pool robbing you of leisure time? Meyco safety pool cover takes just two minutes to put on or remove. Keeps out dirt, leaves and such; children and pets are safe when you're away. Discourages algae. Custom made for any size. 15' by 30', \$229 complete, ppd. Meyco, HG10, 138 Haven Ave., Port Washington, NY 11050.

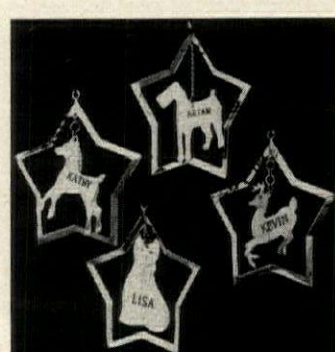

CHRISTMAS STARS
Each gold-plated metal 3" star has a different animal plus a first name. A delightful favor for a pre-Christmas birthday party. Choose pony, pussycat, terrier or reindeer; \$1 each plus 25c post. Order one for all the little and big people. Lillian Vernon, Dept. G01, 560 So. Third Ave., Mt. Vernon, NY 10550.

CRYSTAL CLEAR ACRYLIC CANDLE HOLDERS

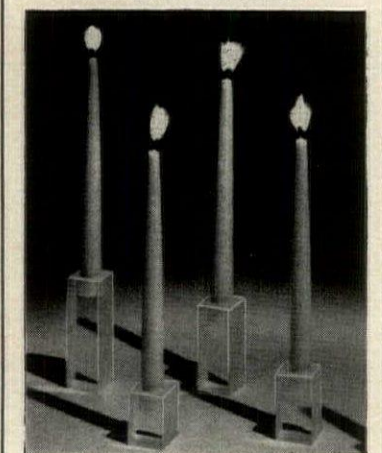

- Set of four \$9.95 PPD.
- 1½" Thick (PA. RESIDENTS ADD 6% SALES TAX)
- Height: 2", 2½", 3½", 4½"
- Send check or money order to:

FORM / FUNCTION ACRYLICS
Box 1475 Allentown, Pa. 18105

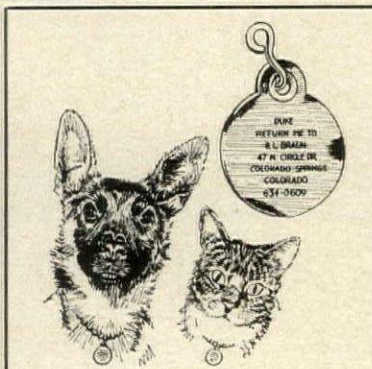

LIFE LONG ID TAG FOR PETS

Don't worry about your dog or cat getting lost. This Identification Tag has all the necessary information for his safe return — pet's name, your name, address and phone number — all embossed free. Lifetime polished stainless steel, complete with collar hook. \$1.00 ppd. Your order will be sent by FAST FIRST CLASS MAIL at no extra charge!
WEST-BERG ENTERPRISES, LTD.
Dept. 210-A, 2842 E. Serendipity Cr. Colorado Springs, Colorado 80917

25c SAMPLE OFFER, if you're interested in
ANTIQUES

Fascinating new newspaper devoted to Antiques, is chock-full of interesting items for collectors

At last, America has its own sprightly, wide-awake newspaper devoted to Antiques. Edited with skill and knowledge. This big 56-page newspaper is full of good reading, to keep you interested by the hour! Oversized clear pictures... with color features. Authoritative articles by experts. Collectors interested in furniture, china, glass, prints, silver, etc. . . write us: "Your newspaper is the best thing I've read!" Also, up-to-the-minute news about shows, exhibits, forums, historic sites. Plus a delightful classified section, where the bargains are!

Now we want you to enjoy *Antique Monthly*, for just 25c to cover postage and handling. We'll send you the current big issue, postage paid. No further obligation. Fill in coupon and get set for lots of reading enjoyment. (America's largest publication devoted to fine Antiques)

25c SAMPLE OFFER:

Antique Monthly, Dwr. 2, Tuscaloosa, Ala. 35401
() Send me sample copy, your issue No. G-101. I enclose 25c. () Send me full 12-months' subscription at special reduced price of \$4.99. Bill me later. (Your money refunded after 30-day trial, if not pleased)
Name _____
Address _____
Zip _____

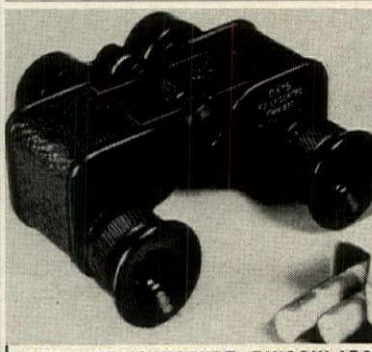

NEW SUB-MINIATURE BINOCULARS

- Less than 3" high!
- Powerful 6 x 15
- Wide Angle View
- Fully Coated lens
- Weighs only 5½ ounces!

SHIRT-POCKET SIZE, BUT ACTUALLY SUPERIOR TO BIG GLASSES!

These powerful Sub-miniature binoculars are hardly larger than a pack of cigarettes and weigh less than 6 ounces! Perfect for baseball, football games, bird watching, hunting, sailing, camping, horse races — you name it. Precision made, these binoculars feature smooth center focusing, plus diopter focusing to compensate for any difference in eye strength. Also included are black leather carry case, adjustable case strap, 4 protective lens caps, Jeweler's lens cloth and instructions. Truly a beautiful instrument, backed by a written guarantee.

Price \$29.95 ppd.
Michigan residents add 4% sales tax.
KEATING'S HOUSE OF GIFTS
Dept. HG 100
3494 Tiptecanoe, Monroe, Michigan 48161

SHOPPING AROUND

DRAPE SHAPE

Finesse shows up in a super softie made of angora to drape any which way. Fills the bill for *what to wear* with knit suits, pants or furs. Contemporary *Cuddle Cap* shows up in black, brown, white, camel, gold, navy, mauve. Packs well. One size fits all. \$7 ppd. Frances-Morris, HG10, Box 1270, Brooklyn, NY 11202.



PLACECARD PRETTIES

Compliments abound when your table features capiz shell butterflies to hold the placecards. Imported from the Philippines, these handmade beauties let guests know they're special. 2 3/4" w., 2" h. Set of four, each a different color, \$5.95 ppd. Order now for your next luncheon bridge party. Reizenstein's, HG10, 300 6th Ave. Bldg., Pittsburgh, PA 15222.

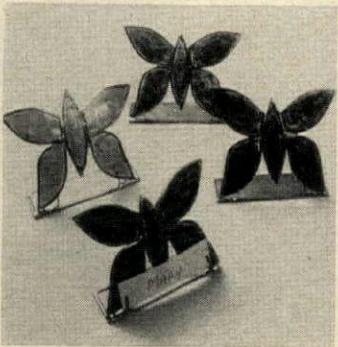

MARKED CARDS

Deck of tricksters has tapered edges for sure touch selection. There is a variation in the back design that lets you distinguish any card held by opponents. Deck comes with complete instructions plus 21 different tricks. \$1.98 plus 20c post. Order #161. Anthony Enterprises, HG10, 585 Market St., San Francisco, CA 94105.



LET'S FACE IT

Gently is the way to go about skin care. We all know that. It makes sense especially when time to clean up blackhead on the oily parts of face. After a gentle wash and pat-dry, use Vacutex to lift clogged pores out smoothly. Vacuum pressure is safe, non-marking. \$1 ppd. Walter Drake, HG-60 Drake Bldg., Colorado Springs, CO 80901.



MINI PHONE

Mini madness invades the communications field! Mini-phone from Italy folds in half—a complete self-contained unit. World's smallest phone functions interchangeably with any standard instrument. Fitted with plug; ready to use. White only. \$49.95 plus \$1.50 post. Free catalogue. Grand Com, Inc., HG10, 1152 Sixth Ave., New York, NY 10036.



BE RINGED

Whether it's old-fashioned or way-out modern, ring designs on a wide band show up to great advantage. Here the stones are modern Strongite—strong is the word, set traditionally—a one carat pear design surrounded by 14 small ones on a 14k white or yellow gold band. \$78 ppd. Free catalogue. The Strongite Co., HG10, 2 W. 47 St., NY 10036.

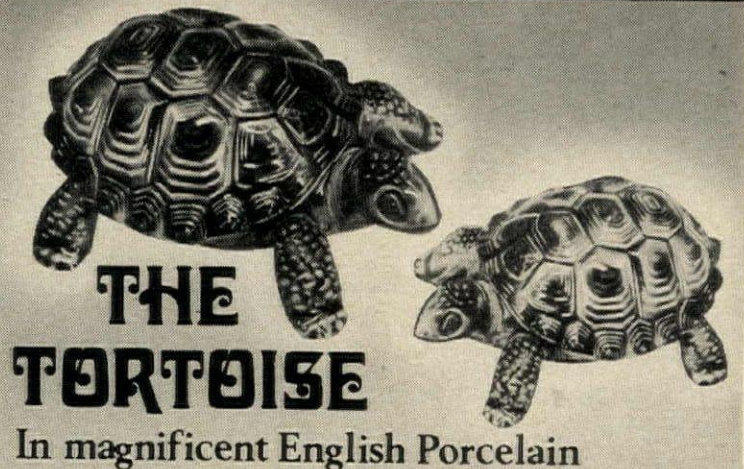
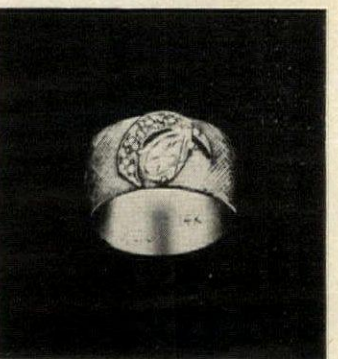

THE TORTOISE

In magnificent English Porcelain

Collector Treasures in delicate porcelain creates superb decorating effects.

\$300
The Pair

... Imagine the luxury of owning Genuine English Porcelain for a fraction of the price you'd expect to pay. Glamorize your home with this rare pair of matching tortoises made by the famous Wade in England. Each piece looks like a decorator masterpiece. Each magnificent piece is hand finished and glazed, with delicate details by proud artisans with amazing skill. They will provide exciting decorator accents in your china cabinet, on your shelves, mantle, table and impress your guests. They add irresistible charm and beauty to any decor—you cannot possibly appreciate the beautiful colors and craftsmanship from the black and white illustration shown. See the delicate beauty and charm captured in your own home by mailing the coupon or visiting our store. Supply very limited. These valuable English Porcelain Tortoises are hand made, so we urge you to order now!

Mother tortoise shown is 3 1/4" long x 2" wide x 4 1/2" in circumference in delicate hues of beige and blue.

Mother and baby, as shown above, only \$3.00 a pair.

Father with matching colors—comes with removable shell (holds accessories) large 4 1/2" long x 3" wide x 6 1/4" in circumference.

See coupon for quantity savings. **COME IN OR MAIL COUPON**

WORLD ART & GIFT-SHOP DEPT. 10HG, 606 POST ROAD, WESTPORT, CONN. 06880
Please send English Porcelain Tortoises as indicated below. Satisfaction Guaranteed.

- Mother and baby—only \$3.00 the pair.
 Father with removable shell to hold accessories—only \$3.00.
 Complete set—mother, baby and father in matching beige and blue—only \$5.00.

Please add 80c postage on all orders.

NAME _____
ADDRESS _____
CITY _____ STATE _____ ZIP _____

IMPORTED FROM HOLLAND

LILIES-OF-THE-VALLEY

RARE, FRAGRANT

- Blooms Indoors in 17 days
- Blooms Again and Again Summer After Summer
- Fabulous Fragrance

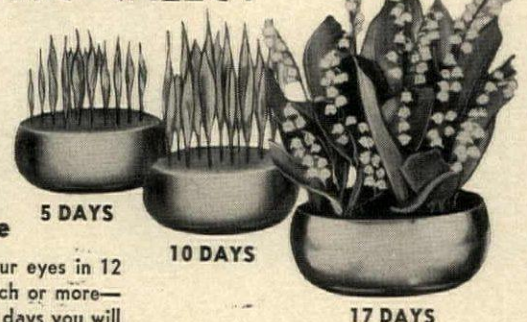

IMAGINE! Right before your eyes in 12 hours they often grow an inch or more—inside your home. In just 17 days you will enjoy a fabulously beautiful indoor blooming flower garden with lovely clusters of bold white bells on 10" stalks (up to 12 flowers per stem). Winter hardy. Blooms Summer after Summer. Perfect outdoor bedding plant with dainty fragrant flowers. Just add water and watch them shoot up.

7 Lily of the Valley Pips in Cornell Growing Mixture only \$1.98.

5 Lily of the Valley Pips—Planted in indoor Plastic Planter \$1.98.

7 Lily of the Valley Pips—Planted in Old Fashioned Brass Type Bowl—\$5.95.

INDOOR-DWARF ORANGE TREE

Imagine plucking and eating your own fresh fruit.

True Miniature-Orange Tree. Grow dwarf size fruit indoors—larger fruit—by planting outdoors this spring. See them bud, burst into delicate Orange Blossoms, rare perfume... bear a succession of delicious fruit. Comes to you in 4" pot about 24" high—

only \$3.95 plus 70c postage.



EASY TO GROW IN YOUR HOME

WESTPORT WORLD ART & GIFT SHOP

Dept. 10-HG

606 Post Road

Westport, Conn. 06880

FURNISHED IN EARLY AMERICAN?

Send 25¢ For Famous
Sturbridge Catalogue
"1,000 Pictures Of Basic
Items For Furnishing An
Early American Home"

Everything in Early
American. All by mail at
modest prices. Money-Back
Guarantee even includes shpg. chgs.



HUNDREDS OF
GIFTS WITH AN EARLY
AMERICAN FLAVOR

100,000 people a year visit our Shop



STURBRIDGE YANKEE WORKSHOP
the Nation's Center for Early American

5101 Brimfield Turnpike, Sturbridge, Mass. 01566

Coats of Arms

OVER
500,000 Names
32 Countries

FREE CATALOG

The Ship's Chandler
Dept. G121
Wilmington
Vermont
05363

ALL
GALS



SHOECRAFT 603 FIFTH AVE.
NEW YORK 10017

Send Today for FREE 64 page Shoe Booklet H

See how easy it is to be fitted Direct via Mail in Shoecraft Famed Fifth Avenue Shoes. Great values now at Low Money Saving Prices.

NO RISK TO YOU!
Satisfaction Guaranteed
or Your Money Back.

SAVE MORE MONEY!

No Extra Charge for
Any Sizes 9 to 13
BRONCO \$27.00

Shades of things to come
... the "futuristic" ghillie.
Surfacing with soft shadows
... moving on a hefty sole.
Melting hues of black or
antiqued tobacco calf ...
laced with rope.

A Catalog of Classics

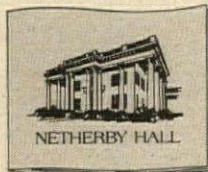

Period
Furniture
•
Woodenware
•
Braided Rugs

A 24-page, full-color catalog featuring elegant accent pieces, distinctive giftware and accessories. Faithful reproductions of authentic Victorian furniture in Honduras mahogany—hand-carved walnut giftwares—and colorful, Colonial-style, pure wool braided rugs. Shop Netherby Hall at home and save at factory-to-you prices! Send \$1 for catalog. It will be refunded on first purchase. Satisfaction guaranteed.

—Netherby Hall, Box 27501, Station 7, Atlanta, Ga. 30327

Netherby Hall, Box 27501, Station 7, Atlanta, Ga. 30327.

I enclose \$1 for your latest full-color catalog which will be refunded on my first purchase.

Name _____
Address _____
City _____ State _____ Zip _____

HG

Cosmos Gems



Flawless miracle of science—shaped, polished and cut with 58 facets just like a diamond—even more dazzling and fiery... Send for FREE booklet of bridal sets, cocktail rings, earrings, pendants, men's rings, and unmounted stones.



COSMOS GEMS LTD. DEPT. N-149
Hanover, Penna. 17331

Name _____
Address _____
City _____ State _____ Zip _____

SHOPPING AROUND FOR CATALOGUES

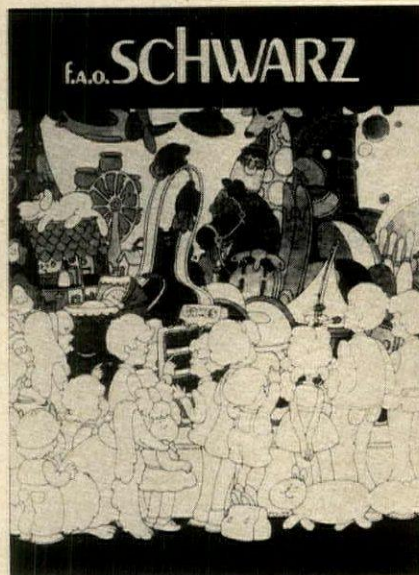

TOPS FROM TOYTOWN

The world's most famous toy store offers a new 154-page catalogue. Twelve hundred exciting Christmas ideas. Exclusive educational playthings, marvelous stuffed animals, cars, books, crafts. Dolls! Antiques, sporting goods, too—and all indexed. \$1. F. A. O. Schwarz, HG10, 745 Fifth Ave., New York, NY 10022.

GOODY BOOK

Delicious and different! From the fruit and delicacy experts, Harry and David, a big colorful catalogue. Free Christmas book of gifts features perfectly packaged fruit, fabulous foods, and great gifts. No sizes or styles to fret you, just lots of good taste for holiday gifting. Write Harry and David, Box L200A, Medford, OR 97501.

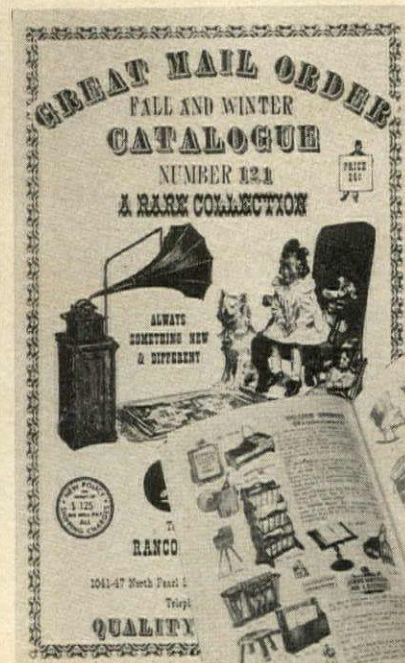

GREAT MAIL ORDER!

Copious collection of happy choices for hearth and home. Americana lovers, harken to this quality collection of weather vanes, cupolas, ornamental signs, mail boxes, hitching posts, sun dials. Beautiful brassware, lanterns, clocks, chandeliers—furniture too and more! Send 25c for catalogue to William Spencer, HG10, Rancocas Woods, NJ 08060.

KIMBALL QUALITY

Superb service and true value always delivered by our friends at Miles Kimball. Ready now for Xmas in October—2000 gifts under \$5! Suggestions to satisfy every age—toys for all, helpful housewares, ideas to intrigue every name on your list. Always free. Just write Miles Kimball, 227 Bond St., Oshkosh, WI 54901.



SILVER SERVICE

Send to Simmons for their new brochure "The Art of Silver Replating and Repair" plus a representative price list, a folder on a hard to find gold-plating service. Included, too, a circular describing their own superb silver polish that's great, too, for gold, copper, brass and pewter. Write to Simmons Silver Plating Co., Inc., HG10, 409 Whitehall St. S.W., Atlanta, Ga. 30303.

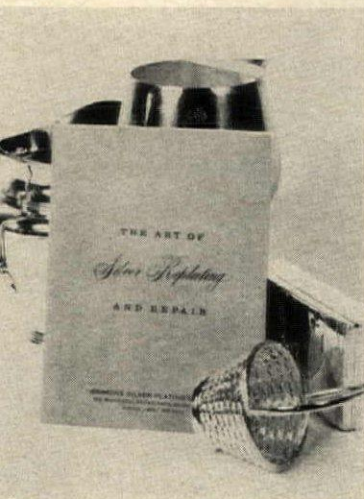

FABULOUS FRUITS

Mighty Mission Pak gathers great gifts from old orchards planted by padres from the Spanish mission days. Colorful free catalogue abounds with fresh fruits, fruit and cookware combinations, nuts, cheeses, cookies, candies, cakes and preserves. Bonus: fine meat selection. Mission Pak; HG10, 3019 E. Maira, Compton, CA 90221.

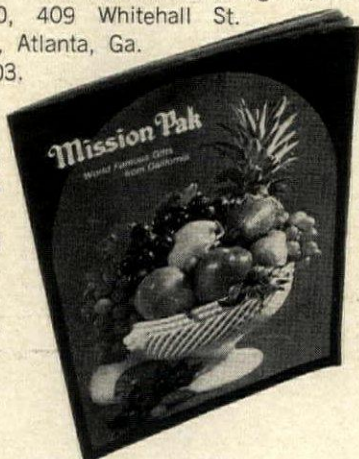

GIFT GALAXY

That something special is what you'll find in this unusual catalogue from this fine Kentucky shop. The best in china, porcelain, sterling, gourmet accessories—the special gift but something for every budget. Free from E. Stephen Hein, Inc., HG10, Gardendale Plaza, Lexington, KY 40504.



HAND-CRAFTED!

Superlatively skilled students from Appalachia fashion fine gifts for every age and interest. Proceeds put these fine young craftsmen through college. Send 25c for illustrated catalogue of broomcraft, ceramics, weaving, lapidary, needlecraft and woodcraft. Berea College Student Industries, HG10, Box 2347, Berea, KY 40403.



FALL FASHIONS

We dare you to look through Carroll Reed's free color catalogue! You won't be able to resist ordering a knockout patchwork pair of pants for pa, Hansel and Gretel togs for the tots, the slug-striped skirt for firelit evening (for you, of course). Much much more, so write Carroll Reed, HG10, North Conway, NH 03860.

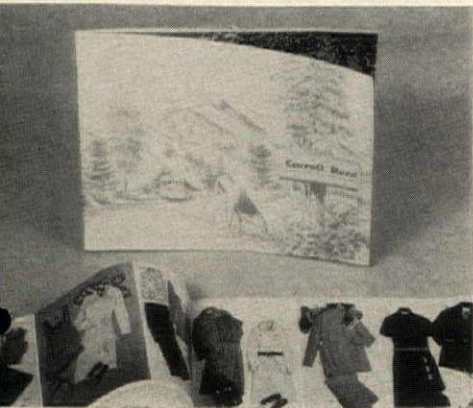

NEW HOME DECORATING & GIFT CATALOG

from

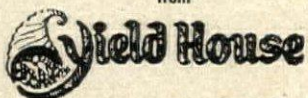

COMPLETE
76-PAGE COLOR
IDEA BOOK JUST 25c

Special 25th Anniversary Edition! Over 1,200 furniture items, accessories and gifts—dozens of beautiful and practical ideas for your home. Features our own New Hampshire made pine furniture, complete and in money-saving kits. Plus a wide and unique selection of accessories and gifts. Something for every taste—and every budget!

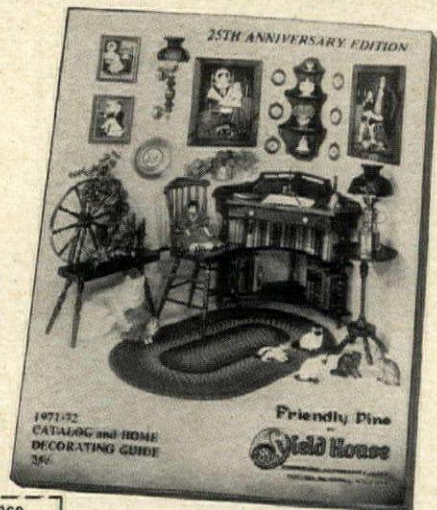

YIELD HOUSE, N. CONWAY, N.H. 03860
Dept. G10-B

Please send me a copy of your Complete Decorating & Gift Guide. I enclose 25c for postage and handling.

Name _____
Address _____ Apt. No. _____
City _____ State _____ Zip _____

OUR SPECIALITIES

Tables	Bars	Pewter
Chairs	Shelves	Copper
Desks	Lazy Susans	Iron
Chests	Clocks	Brass
Racks	Lamps	China
Benches	Prints	Crystal
Tea Wagons	Mirrors	Wicker
Hutches	Sculpture	Toys
Dry Sinks	Crafts	MORE!

SHIP MODELS:

Both ready-to-build kits and finished models for home or office. From \$8.95.



Send 25¢ for 144 page

Ship & Sea CATALOG

Fully Illustrated Catalog shows 51 ship models, over 100 pictures; and decorative Marine items by the score.

MARINE PICTURES

Full color reproductions of world famous ship and sea pictures.



SHIP'S FIGUREHEADS:

Replicas of decorative carved figures from old sailing ships. From \$12.95.



SHIPS' WHEELS:

Of mahogany or oak; for tables, ceiling lights or wall decorations.



MINIATURE CANNON IN BRASS:

Hand built or in kits—for bookends, shelf or desk. From \$6.95.



144 pages of unusual nautical items for the home or office.

Send 25¢ for catalog to: **PRESTON'S**
101-T Main St. Wharf, Greenport, N. Y. 11944

NEW! SHOPPING INTERNATIONAL'S

56-page Fall Magazine-Catalog

Over 600 Gifts from 30 Countries
...20 pages in vibrant Full Color

Take an around-the-world shopping tour of the world's finest handicrafts from your armchair! This fall we feature a trip to Viking Country for Scandinavian pewter, woodenware, wrought iron. Then to Israel for olive wood carvings and Yemenite jewelry; Japan for silks and lacquerware; India for brassware, ivory, exotic jewelry; Italy for alabaster and Florentine leather; Germany for steins and toys. Then there's Mexico, Yugoslavia, Russia, Morocco. So come fly with us, and shop the world!



To take this tour send 25c for our colorful new 56-page catalog with hundreds of new handicrafts from \$1 to \$75.



SHOPPING INTERNATIONAL, INC.
556 Shopping International Bldg.
Norwich, Vermont 05055

The Museum of Modern Art Christmas catalogue

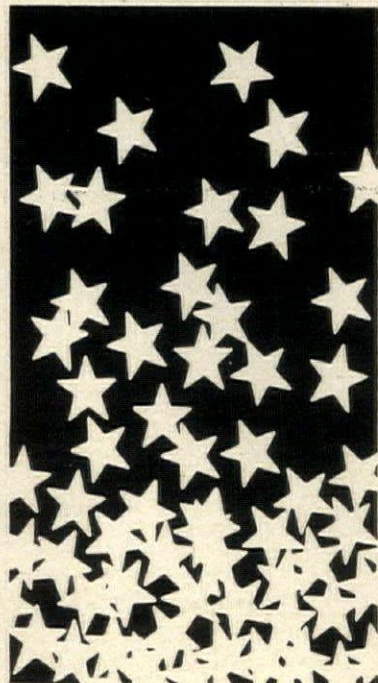

An illustrated, full-color, 40-page catalogue presenting new cards and constructions, original graphics and sculpture, design objects, books, reproductions, and a wide selection of distinctive gifts from The Museum of Modern Art is now available. Cards and constructions—20¢ to \$2—reproduce classic works by artists in the Museum collection. Others have been specially commissioned from such artists as Jim Dine and Sydney Butchkes. Gifts ranging from \$2 to \$400 include *Nudes: 1972 Appointment Calendar*; a special edition of *Playfax*; original signed and numbered color lithographs by Robert Indiana and Roy Lichtenstein; *The Ball Puzzle*, Charles Perry's exquisite lucite object; illustrated gift books by Ben Shahn, David Hockney, and Niki de Saint Phalle; and the Ernest Trova *Kaleidoscope*—an unusual version of a classic Christmas toy.

The Museum of Modern Art 013
5300 Lenox Hill Station
New York, New York 10021

I enclose 25¢ for the 1971 Christmas catalogue.

Name _____

Address _____

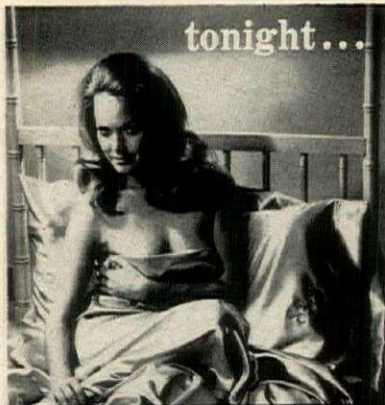

tonight...

satin sheets.

Ours are unbelievably soft, luxurious and washable... the finest acetate satin. Twelve shimmering shades: Gold, Black, Blue, Bronze, Orchid, Olive, Red, White, Mint, Pink, Orange, and now, SILVER!

SHEET SETS (2 straight sheets, 2 cases)
 Double Set \$17.50 Queen Set \$20.49
 Twin Set 17.25 King Set 23.99

3-letter monogram on 2 cases—\$2.00
 For fitted bottom sheet, add \$2.00 to double or twin price; \$2.50 to queen price, \$3.00 to king price. Send check or m.o. 50% deposit on C.O.D.'s.

SCINTILLA® INC. 4802 N. Broadway G-10
 Chicago, Ill. 60640
 "All Things Exotic In Satin"

STACKABLES
 for neat storage

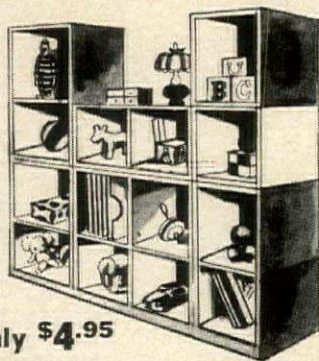

only \$4.95
PER SET OF 3 CUBES

Ideal where hazards or economy prevent use of costly furniture. Designed of RIGID FIBERBOARD on basic 12-inch or 14-inch Cube. Set Cubes side by side or on top one another to form room divider, wall or section for storage of books, toys, clothing, radio, documents, knitting—anything! Great for playroom, den, basement, attic. In Oyster White for use as is or decorate to taste. Set of three 12-inch Cubes \$4.95 plus \$1 postage. 3 Sets (9 Cubes) \$14.95 postpaid. Set of three 14-inch Cubes \$6.50 plus \$1 postage. 3 Sets (9 Cubes) \$18.75 postpaid.

PEGASUS Dept. HG-10
 175 Lauman Lane, Hicksville, N.Y. 11801

SHOPPING AROUND



SKATING BARTENDER
 You've heard of singing waiters? Well, here's a skating bartender! Wind him up, top with a drink, and send your guest his pleasure Special Delivery. Flags blaze a toast—"Cheers" and "Lachiam." Automatically stops at bar's edge. Works without batteries. \$2.49 plus 30c post. Anthony Enterprises, HG10, 585 Market St., San Francisco, CA 94105.

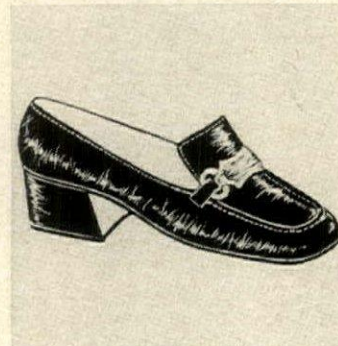

LONG AND LOVELY
 Sleek and shiny, wrinkle patent looks just right for October football weekends. Gilt hardware glitters from a highish vamp made-to-order for pants and textured hose. Black, dark brown and white. Sizes 9 to 14, N, M. \$15 ppd. A versatile addition to the tall gal's shoe wardrobe. Free catalogue. Shoecraft, Inc., HG10, 603 Fifth Ave., NY 10017.



CHIEF SPOOF
 Hail to the punster who came up with this perfect put-on. It's all in fun, of course, whatever your party preference. Life-like molded plastic is lightweight, fits any size funster. In color, of course, it's \$4.98 plus 20c post. Order from Anthony Enterprises, HG10, 585 Market St., San Francisco, CA 94105.



14" Marble-top table in solid mahogany \$19.95

Romantic Victorian
 solid mahogany, hand-carved furniture!

New way to save on finest quality furniture. Shipped direct from factory to your home (plus small freight). All tables have marble tops from Italy. Large choice of sofas, chairs, lamps, bedroom, dining room. Superb workmanship at modest prices. America's largest selection here. And, costly fabric cuttings are sent free!

Magnolia Hall, 726 Andover/Atlanta, Ga. 30327

To get big catalog GA101 and costly fabric cuttings, send just \$1. We will refund with certificate good for \$2 on your first purchase.

Name.....
 Address.....
 Zip.....
 Magnolia Hall, 726 Andover/Atlanta, Ga. 30327



The SAFE 2-Way PET DOOR

Much safer than any solid hinged type panel door. Your pet is completely protected. He cannot be trapped or choked or have his tail sheared off.

FlexPort

Why be a doorman for your pet? FlexPort ends scratched doors and whining. Keeps out flies, wind, rain. Gives you and pet complete freedom. Soft plastic triangles close gently and tightly. Easily installed. Send for free folder.

TUREN, Inc., DEPT. HG-10
 2 Cottage Ave., Danvers, Mass. 01923



PARTY PERFECT
 Porcelain menu stand, place card stands ready for gala dinners this fall. Write out menu, names with felt-tip or ballpoint pen, rub or wash off ready for the next party. White with pastel posies. Menu, 5 1/2" by 3 3/4", 12 cards, \$8.98 plus 50c post. Lillian Vernon, Dept. G01, 560 So. Third Ave., Mt. Vernon, NY 10550.

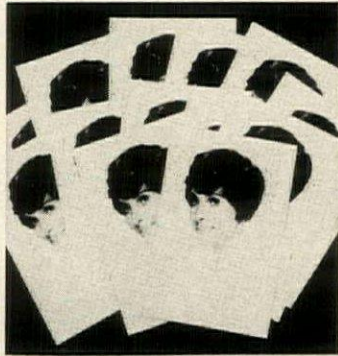

PHOTO FAIR
 Favorite photographs for faraway friends to include with Xmas greeting or job applications. Excellent studio-like look at substantial savings. For color, send color negative, photo or slide. 16 for \$1.98; 32 for \$2.98. Black and white, send any photo or negative. 36 for \$1; 76 for \$2. Add 30c post. Philips Foto Co., HGW-1, Elmsford, NY 10523.



CHANDELIER SPRAY

Just spray it on and allow to dry. Your crystal chandeliers will sparkle in a blaze of glory. 7-oz. spray can protects and preserves all surfaces with an invisible coating of miracle silicone.

CHANDELIER SPRAY
 \$1.98 + 30c Mailing Each
 Calif. residents add 5% sales tax. Satisfaction guaranteed.

Anthony Enterprises Dept. HG-101
 585 Market St., San Francisco, Calif. 94105

TWO-IN-ONE ELECTRONIC MARVEL
PHONE MONITOR & TELEPHONE AMPLIFIER

Can Be Used With Phone on Or Off Hook

This minute-size device used as a phone monitor attaches easily (no installation necessary) to the side of your extension phone and picks up conversations going through the main wire even without lifting the phone off the hook. As a phone amplifier with receiver off hook you can have a hands free conversation without being chained to your phone. This electronic wonder also enables you to listen in on hush-hush conversation your teenager has. At the office, secretaries need to listen in without disturbing the conversation with typewriter noises, etc. Also a wonderful second receiver when more than one party wants to hear the conversation. Has volume control, operates on standard mercury battery (included). Complete with ear plug. Only \$12.95 plus 50c pp. Save \$2.00—two for \$24.95 ppd.

Send Check or M. O. Satisfaction Guaranteed.
J. W. HOLST, INC. Dept. G-10, 1005 E. Bay St., East Tawas, Mich. 48730



ADDRESS LABELS with NICE DESIGNS

Any Initial, American Flag, Pine, Gull, Palm, Roadrunner, Saguaro, Rose. [Also available are Texas Flag, Maple Tree, Treble Clef, or Palette]. Up to 20 letters per line, 4 lines. Printed in black on white or gold gummed labels 1 1/2 x 1/2". Packed in neat plastic box. 500 on white or 250 on gold for \$2 ppd. Or on DELUXE SIZE, 1 3/4 x 1/2" for \$3 ppd. Specify Initial or Design desired. Via air, add 33c per order. Write for Fund Raising Folder, too! Bruce Bolind, 210-L Bolind Bldg., Boulder, Colo. 80302. Thank you kindly!

SHOPPING AROUND

SCENT OF CHRISTMAS

Glittering holiday candle surrounded by scarlet poinsettias and holly is a festive centerpiece. Candle burns for 25 hours, is scented with bayberry. Choice of gold, red or green. \$1.79 each plus 75c post.; two, \$3 plus 90c post.; four, \$5.50 plus \$1.25 post. Nel-King, HG-10CT, 811 Wyandotte, Kansas City, MO 64105.



HEAP BIG HOLDER

Big chief astride his handsome mustang is bound to encourage boys and girls to stow their toothbrushes and use them twice every day. Chief wears colorful authentic headdress and costume. 8" high composition figurine. \$2.49 plus 50c post. World Co., HG10, 2 First St., E. Norwalk, CT 06855.



SEE-EASY—THERMOMETER

Autumn's in the air; whether Indian summer or a whisper of winter you need to know the temperature. See through thermometer sticks outside a window and lets you size up the season in a wink. Even youngsters can read the exact degrees. 3½" by 2½". \$1.79 plus 20c postage. Anthony Enterprises, HG10, 585 Market St., San Francisco, CA 94105.

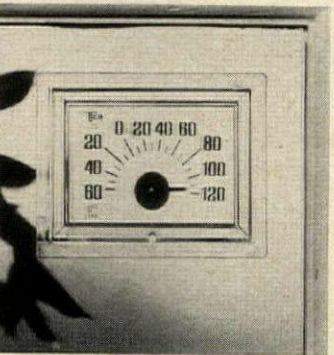

BLUES IN NEEDLEPOINT

One of Sylvia Sidney's designs in needlepoint is available in kit form to make an 18" by 18" pillow by easily combining four simple stitches. Kit includes canvas for pillow top, Persian yarns in four shades of blues and white, needle, instructions. \$11.95 plus 75c post. The Stitchery, HG10, Wellesley Hills, MA 02181.



FEMME'S GEM

Ladies fairly sparkle at the sight of a Kenya gem. Man-made oval cut glitters like the precious stone. But, the price is right—\$85 for one carat, \$125 for two. (Pay-by-the-month terms too.) For a dazzling duo add matching wedding band, \$25. Shipped registered air mail by Kenya Gem, HG10, 1760 No. Howard St., Philadelphia, PA 19122.

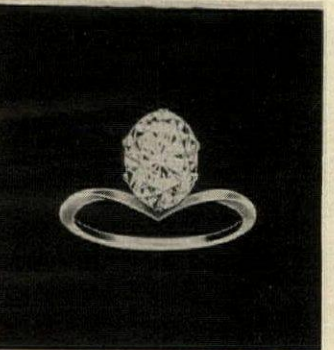

FOR AN ORDERLY HOME: MAGAZINE BASKET

Here's a handy, dandy accessory piece that not only keeps things in apple pie order 'round the house, but has the unmatched beauty, charm and elegance of graceful Colonial days. A convenience for den, living-room, recreation room, hallway entrance, any room. Hand-rubbed finish. Solid hard-rock maple. Honestly built with smooth turnings and rounded edges. Made for contemporary, leisurely living. Available in natural wood tone or dark distressed maple finish. (Specify choice when ordering.) 17"x13"x16". SATISFACTION GUARANTEED. Excellent gift. Only \$19.95. Sorry, no COD's. Shipping charges collect. Send check or money-order to:



THE TOP DRAWER P.O. Box 12094, Dept. HG, Atlanta, Ga. 30305

"World's Greatest"

- Lover
- Grandfather
- Grandmother
- Liar
- Son
- Driver
- Movie Star Fan
- Teacher
- Mother
- Dancer
- Actor
- Actress
- Golfer
- Mother-in-Law
- Sports Fan
- Bowler
- Little Leaguer
- Boss
- Bartender
- Doctor
- Fisherman
- Football Player
- Hunter
- Lawyer
- Salesman
- Tennis Player
- Dentist
- Bar-B-Q Chef
- Business Man
- Dice Player
- Pilot
- Photo-Bug
- Skier
- Musician
- Barber
- Baseball Player
- Drinker
- Sweetheart
- Beau
- Navigator
- Muscleman
- Basketball Player



TROPHY CUPS

Miniature, gold plated styrene Trophy Cups, beautifully engraved with the titles listed. 4" x 1½". Walnut Base. \$1.29 Each. Add 15c postage per cup.

"World's Greatest"

- Daughter
- Card Player
- Friend
- Nurse
- Record Collector
- Father-in-Law
- Bachelor
- Gambler
- Big Shot
- TV Fan
- Husband
- Wife
- Brother
- Sister
- Dad
- Mom
- Couple
- Guy
- Fink
- Rockhound
- Hair Stylist
- Genius
- Secretary
- Coin Collector
- Host
- Waitress
- Cook
- Bridge Player
- Father
- Numismatist
- Beer Drinker
- Scotch Drinker
- Bourbon Drinker
- Martini Drinker
- Surfer
- Sailor
- Soldier
- Marine
- Airman
- Kibitzer
- Smoocher
- Grouch
- Dope

MISCELLANEOUS TITLES:

- I Love You
- You're A First Class Goldbrick
- 7th Vice President
- World's Greatest
- You've Got A Heart Of Gold
- The Hostess with the Mostest
- It's a Boy
- It's a Girl
- World's Worst Fisherman
- World's Worst Golfer
- World's Worst Bowler
- World's Cutest Baby
- World's Most Patient Husband
- World's Most Patient Wife
- World's Worst Card Player
- World's Worst Driver
- Hero Driver
- First Prize
- Second Prize
- Third Prize
- Blank Plaques

Include 15c postage per cup. Satisfaction guaranteed. Calif. residents add 5% sales tax.

Anthony Enterprises Dept. HG-101, 585 Market St., San Francisco, Calif. 94105



BLUE WINGED TEAL



RUFFED GROUSE



CANVAS BACK DUCKS



MALLARD DUCKS

Audubon's Gamebirds in Hand-crafted Woodprints

MOUNTED READY TO HANG

A full 11½" by 15" (approx. 50% larger than this magazine), these handsome full-color lithographs of J. J. Audubon's classic gamebird series are bonded into ¾" thick solid blocks. Each block is hand-carved,

with a mellow stained finish and carefully antiqued. Fit any decor. Beautiful hung as a group. Excellent gift idea. Full set saves you 24% on unit price.

ONE...\$ 5.95 THREE...\$ 13.95

TWO...\$ 9.95 FOUR...\$ 17.95

Guaranteed money back if not delighted.

Please add \$1.00 postage and handling.

WoodSmith Gallery, DEPT. G10, S. WARDSBORO RD., WARDSBORO, VT. 05355



Wild Rice

Your gift from Minnesota

A new crop from the hidden lakes of our north country. Prized for centuries by the Indian for its rare, nut-like flavor. The ultimate with game, fowl, and casseroles. Easy instructions and recipes included. While available—½ lb. (10 lg. servings) \$3.45 plus 45¢ postage. Sells for \$12 lb. and more in gourmet shops.

New 72 pg. catalog—25¢.

Suburbia, inc.
Mail Shopping Service

366 Wacouta, Dept. 303, St. Paul, Minn. 55101



BUILD these Beautiful CLOCKS

Now at big savings! Send just \$1 for plans & instructions to build choice of: (A) Grandfather (B) Banjo (C) Steeple (D) Grandmother plus information-packed catalog of movements, dials, parts & kits to build these & 15 other fine clocks. All 4 plans \$3.50. Catalog alone—25c.

MASON & SULLIVAN CO.

Dept. HG-10, Osterville, Mass. 02655



Espana Pedestal Table

To display just one prized *Objet D'Art*. Perhaps a piece of sculpture; a treasured bowl; an antique vase. Imported from Spain, intricately hand-carved wood is finished in a rich, deep walnut. Whether you're a Spanish "Aficionado"—or just love our table, you'll recognize the unusual value. 21" high; 7" x 7" top.

\$10.95

Postpaid

N.Y. residents add applicable sales tax.

THE FERRY HOUSE
Dept. G-101
Briarcliff Manor
New York 10510

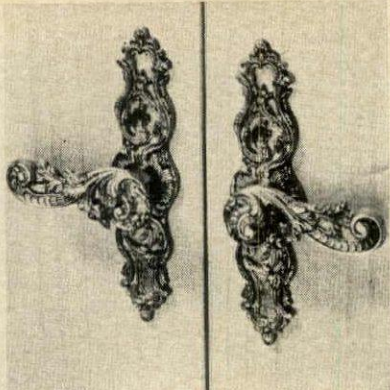

French Doorknobs \$2.98 ea. GOLD PLATED GLAMOR—NOW IN LEFT- OR RIGHT-HAND STYLE!

Instant drama for your doors—fabulous design! Inspired from a priceless original! Cast metal, lavishly 18K Gold plated, antiqued to enhance every exquisite detail, lacquered for lasting tarnish-resistance. Each complete with 8" back plate, spindle, brass screws. Choose left- or right-curving knob, customized for every door.

#1930—Left-hand Knob.....\$2.98 ea., 2 for \$4.98
#1927—Right-hand Knob.....\$2.98 ea., 2 for \$4.98
#1931—Set of 1 each, left & right.....Set \$4.98

Please add 35c post. & hldg.

LILIAN VERNON Dept. G01,
560 S. 3rd Ave.
Mt. Vernon, N.Y. 10550

SHOPPING AROUND

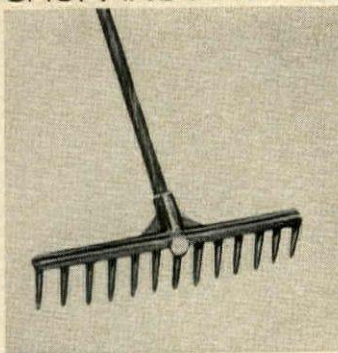

RUG BEAUTY RAKE

We love our shag rugs, but it's a job to keep those tufts from matting down, so the introduction of the shag rug rake is a happy new household companion. The wooden rake is sturdy and light in weight, with a durable 14" high-impact head and 13 tines. 4' handle. \$3.95 ppd. The Gift Tree, HG1071, Box 55, Kensington, MD 20795.

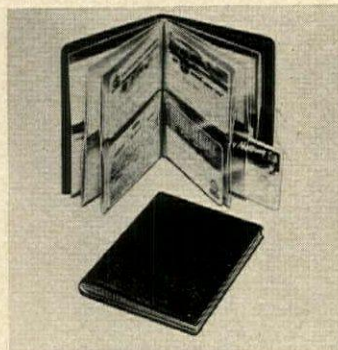

POCKET SLIMMER

Credit card case and wallet in pigskin holds 24 credit cards plus cash, notes, checks. It retains its 4" by 5 1/4" by 1/2" contours to slip into man's pocket or lady's bag. See-through holders for cards plus five pockets. Tan or black Morocco. \$3.99; two, \$7. Add 50c post for one, 75c for two. Jay Norris Corp., Dept. QE-29, 31 Hanse Ave., Freeport, NY 11520.



GLEAMING CRYSTAL

A lovely pair of crystal lamps sets a mood of elegance with its shower of imported crystal prisms combined with intricate Rogers gold-plated castings. In shining glory they cast radiant rays for special lighting effects. 17 1/2" high, 9" wide. Pair, \$34.95. Exp. chgs. coll. Catalogue, 10c. Luigi Crystal, Dept. G-10, 7332 Frankford Ave., Phila., PA 19136.



WITCH WAY

If you're about to plan it any which way, hold off for a game with gypsy fortune telling cards. Similar to the Tarot, each of certain cards bears an allegorical representation with a meaning all its own—specially for you, you and you. \$1.98 plus 20c post. Order #115 from Anthony Enterprises, HG10, 585 Market St., San Francisco, CA 94105.

CLASSIC COIN PLAQUES!!



\$11.95 ppd.

The classic Mercury Dime reproduced now in a handsome wall plaque! Five inches in diameter, the Dime is one of a series of coins reproduced in exceptional detail, metalized, antiqued, and mounted on a flocced background, set in a wooden frame.

Perfect for home or office. A GREAT GIFT IDEA!

Other Coin Plaques available: The Buffalo Nickel, The Indian Head Penny and The Walking Liberty Half Dollar.

We pay Postage. Sorry no C.O.D. Your satisfaction guaranteed.

THE MAILSOURCE Dept. HG
P.O. Box 4670 Newark, Delaware 19711



IMPROVED* Model...

HAND EMBOSSEUR For Personalized Stationery

Emboss your own personal stationery for a lifetime by just pressing a handle. Makes expensive looking raised letter impressions of any 3 line name & address on PAPER & ENVELOPES (reversible). Requires no inks, accessories, service or maintenance. Ideal for adults, teenagers, home or office, clubs, etc. Print clearly 3 lines desired. No more than 24 characters per line. For 1 to 3 lines.....**\$8.95**
For 4 lines add \$1.00. Plus 35c each postage
EXTRA PLATE ALONE (no frame) \$7.85 ppd.

NEW! DELUXE DESK MODEL EMBOSSEUR \$10.95 + 50c postage
Send 10c for catalog • Pa. res. add 6% sales tax
POSTAMATIC CO. Box 160, Dept. HG1071
Lafayette Hill, Pa. 19444

STUDY AT HOME



For a Satisfying Hobby or Rewarding Career

Famous **HOME STUDY** course. Individual program prepared and supervised by prominent N.Y. decorators on faculty of long established reputable school with successful graduates all over the world. Lessons cover **Textiles; Furnishings; Room Arrangement; Color Harmony; Period and Modern Furniture; Antiques; Rugs and Floor Coverings; Wall Treatments; Wall Papers; Draperies; Lighting; Pottery; Porcelain; Glass; Accessories.** Details on how to set up your own business or start a career. Illustrated lessons, complete with samples of fabrics, colors, etc. Certificate awarded.

NEW YORK SCHOOL OF INTERIOR DESIGN
155 East 56th St., New York 10022

Send for FREE BOOKLET

New York School of Interior Design
155 East 56th St., New York 10022
Please send me (no obligation) Catalog C21

name.....
address.....
city.....state.....zip.....

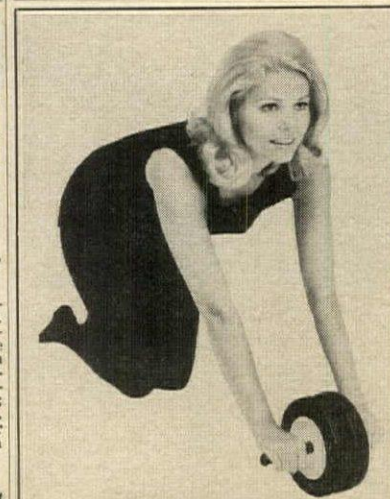

SHRINKS STOMACH

Feel muscles tighten and see stomach shrink from first day. A few rolls back and forth with Wonder Wheel from knee position equals 100 sit-ups.

Single Wonder Wheel.....\$3.98 Mailing 75c
Dual Wonder Wheel.....\$5.98 Mailing 95c

Calif. residents add 5% sales tax. Satisfaction guaranteed.

Anthony Enterprises Dept. HG-101
585 Market St., San Francisco, Calif. 94105

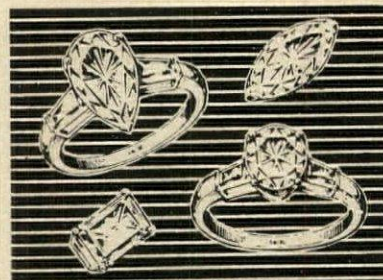

ONLY \$8 PER CARAT FINE CUT • 58 FACETS PURE WHITE • FLAWLESS

STRONGITE is a remarkable, hard and brilliant synthetic stone—the most convincing laboratory-made product, at a fraction of the cost of a diamond. **STRONGITE'S** amazing hardness enables us to offer you an **UNCONDITIONAL LIFETIME GUARANTEE** in writing against scratching, chipping or loss of brilliance. Available in every popular gem shape, up to 20 carat diamond size, and larger. Sold on our easy payment plan and a **MONEY-BACK GUARANTEE** within 10 days. You take no risk!

Write for **FREE BROCHURE** showing wide variety of settings for men and women.

THE STRONGITE CO.
Dept. 99G, 2 W. 47 St. - New York, N.Y. 10036

GIVE COMPUTER ART

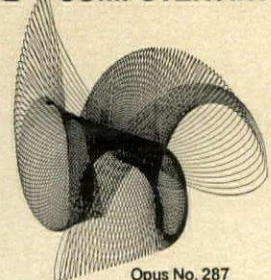

Opus No. 287

The exquisite abstract form shown above is a single continuous line; it is in fact the graphical solution to a set of secret mathematical equations. This particular image, Opus No. 287, is one of a number of original pen and ink drawings by the prominent American computer artist, Henry P. T. Corley. You may obtain a full sized 11 by 14 inch copy of Opus No. 287 signed by the artist from the address below. Not only a conversation piece, your purchase is destined to accrue all the immortality that logically accompanies a cultural development of this magnitude. Permanent, beautiful and rare - this art carries the assurance of substantial intrinsic value. Here is a prestige gift - an investment - that will enhance the reputation of anyone receiving it. Your order includes the picture, background information on computer art, suggestions for framing, and a certificate of ownership registration. Send a check or money order for \$5.95 to Analog Computing, Dept. M, Box 3043, Richmond, Va. 23235.

SHOPPING AROUND

PLAY IT AGAIN

For a music-gifting mood, consider a key ring or cigarette lighter. Choose "More," "Edelweiss" or "Somewhere My Love." Key ring is gold-plated, has a slide cover where you insert a photo. 1 1/4" by 4 1/2" \$12.95. Gold-plated brass lighter, 1 1/2" by 2 1/2" \$25. Ppd. Catalogue, 50c. Hildegard's, HG10, 597 Farmington Ave., Hartford, CT 06105.



SPRAY AWAY

Whether you weekend in Nice or Newark, a stash of grooming aids is *de rigueur*. Purse size refills let you bring your own aerosols without space waste. Fill clear inner bottle with hair spray, fragrance, creme rinse, deodorant. \$1.49 each plus 20c post. from Anthony Enterprises, HG10, 585 Market St., San Francisco, CA 94105.



BATHTUB BOUQUET

Flower appliques in your tub or shower stop skids. Attach instantly in your own design. Mildew proof, textured rubber babies your feet, freshen your bathroom with a springlike look. Choose white, pink or blue. \$2.98 ppd. for eight 5" and eight 3 1/2" blossoms. Walter Drake, HG44 Drake Bldg., Colorado Springs, CO 80901.



BLARING ALARM

City dwellers welcome this pocket alarm to summon help at a sudden attack on the night street. Personal alarm is battery run (not included) and fits in purse or pocket. Use it effectively on doors or windows, too. \$1.98 plus 25c post. Anthony Enterprises, HG10, 585 Market St., San Francisco, CA 94105.

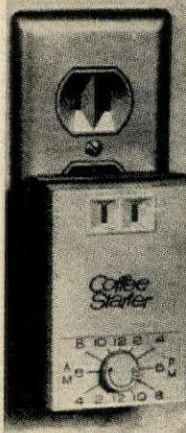

WAKE UP TO FRESH COFFEE

COFFEE STARTER will have your coffee ready when you wake up in the morning. Put water & coffee in pot night before, plug cord into starter, starter into outlet, set time. PRESTO! Next morning your coffee is ready when you roll out of bed. Next best to having someone wait on you. You'll love being spoiled!

No. 191 \$6.98 2 for \$13.85

DO DISHES DOUBLE QUIK

NO MORE DISHPAN HANDS with the best dishwasher on the market at this price.

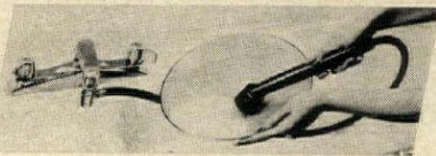

WITHOUT DISCONNECTING water will come thru dishwasher or faucet. Handiest item in kitchen! Push button for instant suds, scrub, rinse, all in one operation. Cleans finest china, worst grease. 30" durable hose, nylon-bristle brush. GET OUT OF THE KITCHEN IN A WINK.

SEND US YOUR GIFT LIST—LET US MAIL DIRECT FOR YOU



Dept. G-1071
P.O. Box 585
Skokie, Ill. 60076

No. 30 \$9.95 50c postage & insurance
no C.O.D.'s please

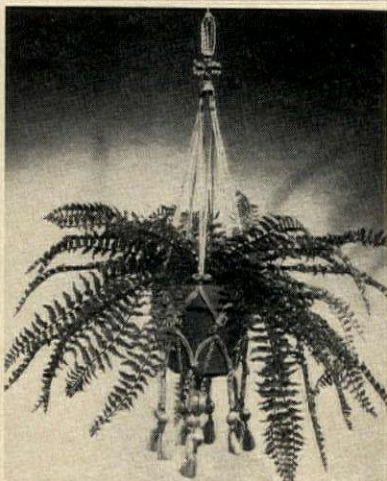

PLANT HANGER. Show off your prettiest potted plants in this charming Shikka from Pakistan. Hand made of braided tasseled hemp in natural color, it has lovely rosettes and decorations of brightly colored thread. 30" long. Decorative setting for live or artificial plants. \$7.95 postpaid.

(Solid color Shikka, smaller and less elaborate, \$3.95 ppd.)

ELIZABETH McCAFFREY
Dept. HG-10S, Northport, N. Y. 11768



LEATHER WING CHAIR

Luxurious in top grain leather, this handsome Chippendale wing chair has a fruitwood finished hardwood frame, full web base, hand tied coil springs, foam and Dacron cushion. Size: W 32 D 33 H 41. Choose oxblood, meerscham, or black leather. Swatches available. \$234.00, shipping charges collect. No C.O.D.

Send 50c for catalog of reproductions.

Dept. 920, Box 266, Concord, N. C. 28025

Ephraim Marsh

WHY STRUGGLE WITH STUBBORN JARS AND BOTTLE CAPS?

Unlock hard-to-open screw cap, jars, bottles and cans in a jiffy.

THE KARY JAR OPENER



A welcome relief—a labor and time saver! It's so easy to use . . . no effort at all . . . no moving parts to get out of order. Adjusts itself to screw and twist caps of any size or type: Pickle jars, baby food, screw top bottles and cans, medicine bottles, etc. Make life easier for yourself—use the amazing Kary Opener in kitchen, bar, workshop, or on picnics.

Rush only \$1.69 plus 31c mailing (Two for \$3.30 postpaid) to:

KARY ENTERPRISES
Dept. H102, 3605 Guilford Rd.
Rockford, IL. 61107



THIS YEAR—MAKE YOUR OWN CHRISTMAS TREE ORNAMENTS

Our kit has 15 different old-style ornaments pre-cut on imported mahogany wood. Just pop them out, paint them by number in bright colors, and assemble. It's easy and fun for the whole family! Each delightful ornament (approx. 4 1/2") has 3 dimensions, giving them unusual depth and beauty. Kit includes sequins, paint, brush, hanging cords and illustrated instructions.

SEND FOR FREE GIFT CATALOG \$4.95 Plus 80c postage No C.O.D.'s

Artisan Galleries

2100 B-10 No. Haskell • Dallas, Texas 75204

An Everlite® Greenhouse your "Garden Under Glass"

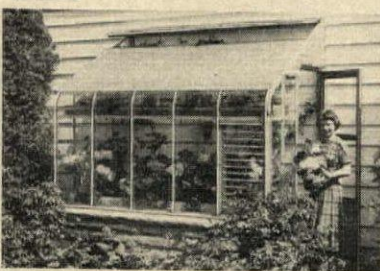

New adventure in gardening . . . an Everlite Aluminum Greenhouse.

★ Wide selection of lean-to or free-standing models. ★ Completely prefabricated. ★ Easy to install. ★ Easy to maintain ★ Full line of accessories.

Live with flowers the year 'round.

Write for colorful brochure and Price List HG-101

Aluminum Greenhouses, Inc.
14615 Lorain Ave. • Cleveland, O. 44111

IRRESISTIBLE



SUZIE SUNSHINE

18" Little Girl, fully jointed with moving eyes, long rooted washable hair tied with big yellow satin bows. She's dressed in a lovely soft yellow cotton Grannie dress with lace-trimmed organdy pinafore, a big sash bow in back. Blonde, brunette or redhead. 2nd choice, please.

She's \$16.95 postpaid. Send to:

THE ENCHANTED DOLL HOUSE
Dept. HG101 Route 7
Manchester Center, Vt. 05255

(Send 50c for our NEW 40 page catalog)

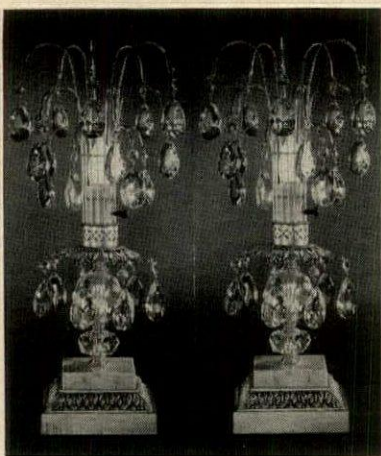

Elegant Crystal Lamps WITH ITALIAN MARBLE BASES

The richness of these handcrafted Rogers gold finished castings and imported Italian marble bases combined with hand cut crystal blocks with imported crystal pendants, sparkling like dew drops is unbelievable at this price. The perfect decorator touch for buffet, mantel, piano or bureau, they are reminiscent of an elegant age. Completely electrified, they are 18" high.

Pair **\$34.95** Sorry No COD's **SHIPPING CHARGES COLLECT**
MATCHING CENTERPIECE AVAILABLE \$29.95
Pa. Res. Add 6% Tax • Send 10c for catalog.

LUIGI CRYSTAL

Dept. HG10-1, 7332 Frankford Ave., Phila., Pa. 19136



Colossal Size Coins

Impressive wall decor for home, office, store, bank. Perfect replicas are molded by hand from dense unbreakable urethane, metal finished, with molded-in mounting. Specify face or reverse side of each coin desired.

Lincoln Head or Indian Head Penny 1 1/4" \$8.95 each. Indian Head or Buffalo Nickel 1 3/4" \$9.95. Mercury Dime 1 3/4" \$8.95. Washington Head Quarter 1 5/8" \$10.95. Kennedy Half Dollar 1 3/4" \$14.95. Silver Dollar (Peace) 2 1/4" \$19.95. Add 75c post. each.



Free Quality Gift Catalog on Request

SLEEPY HOLLOW GIFTS
6651 Arlington Blvd., G10-1
Falls Church, Va. 22042

DOLLS

A THRILLING CAREER AWAITS YOU

YOU LEARN to make and restore dolls of all kinds—old and new. Wonderful hobby, profitable part time business. Turn your love of dolls into rewarding pastime. Design and create doll clothes, repair mechanical dolls, authenticate old dolls. Easy to read lessons and free consultation to insure your satisfaction. **DON'T DELAY**—Start today for your exciting future. Send for **FREE BOOKLET**. No salesman, no obligation.



Norm & Sue Morris

LIFETIME CAREER SCHOOLS Dept. D-982
2251 Barry Avenue, Los Angeles, Calif. 90064

PLEASE SEND FREE BOOKLET

Name _____
Address _____
City _____ State _____ Zip _____

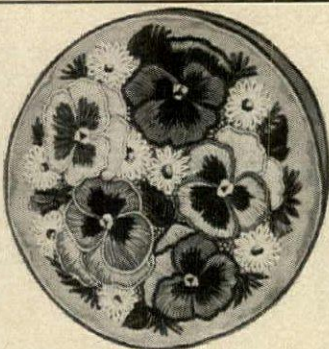

"PANSY PATCH"

Round Box Pillow
for you to embroider

Pansies for a pillow, made by you. You can create this attractive Belgian linen pillow, 14" round, for your home, or as a really personal gift. Everything you need is included. Stamped Belgian linen pillow, 2" wide boxing strip, piping, pillow back, colorful crewel wool, embroidery needle, zipper, and easy-to-follow instructions.

only **\$6.00** plus 35c postage and handling

Satisfaction Guaranteed

N.Y. State residents add sales tax.

STITCHING STUDIO

Dept. HG-101
2 Bridge Street
Plattsburgh
N.Y. 12901



Flower Shoes. Pretty at home or away are our hand-crafted fine leather shoes with everlasting leather flowers on the toes, hard leather soles, and half-inch heels. Navy, red, hot pink, lime, yellow, white or black. Sizes 5 1/2-10, narrow and medium widths. \$16. Add 90¢ for postage.

Send for free catalog.

THE TALBOTS
DEPT. SE, HINGHAM, MASS. 02043
Branches: Duxbury, Lenox, Mass.,
Mt. Carmel, Avon, Conn.

MINI FURNITURE

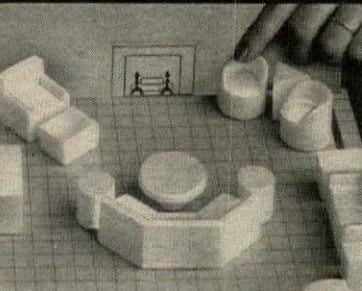

...makes it easy to be your own Interior Decorator!

AVOID COSTLY DECORATING MISTAKES. Create miniature settings for every room in your house before spending a cent for a piece of furniture, a yard of fabric, a roll of wallpaper, or a bucket of paint. Think how much you can save if you really plan before you buy. Over 150 different furniture combinations for every room. Sofas, chairs, sectionals, tables, chests, beds, piano, fireplace, etc. Decorate furniture pieces, walls, with actual fabric and paint samples. Includes: 3-D miniature furniture of Dylite styrene. Graph Board, Walls, Windows, Doors, all to exact 1/2" scale. Design and instruction book included. Created by professional decorator NSID. Guaranteed. Only **\$7.98** (we pay postage).

Plan-It-Kit, Inc. Dept. HG10, Box 429, Westport, Conn.

SHOPPING AROUND



HANG NAPOLEON!

A brooding Napoleon wall hanging originally created in New Orleans in anticipation of his visit is reproduced in hand-cast sculpture and hand-finished in antique bronze. Recently rediscovered, only a limited production allowed; all copies numbered. 12" h. by 15" w. \$36.50 ppd. House of Napoleon, HG10, Box 5024, Beverly Hills, CA 90210.

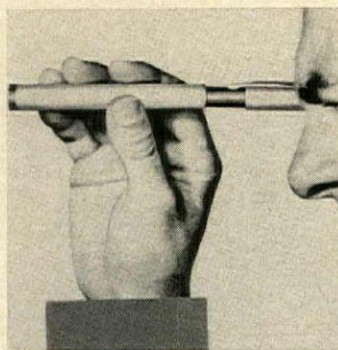

A BROADER VIEW

Pen size 8 power telescope and 30 power microscope are combined in a lightweight aluminum instrument. Pocket clip. Adjusts easily for long range. Converts quickly for precision work. Popular with hobbyists, campers, hikers. \$1.98 plus 15c post. Anthony Enterprises, HG10, 585 Market St., San Francisco, CA 94105.

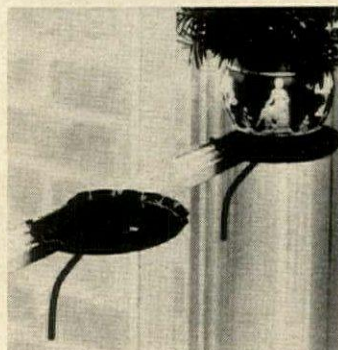

DECORATIVE SHELVES

Perfect for arranging plants or glass objects, are black metal 3/4 round shelves that need no installation. A hanging prong slips between pane and molding; the "stem" presses against pane, holds up to 5 lbs. 4" dia. Set of two, \$2.50; two sets, \$4.50. Add 35c post. Country Gourmet, GO, 545 Fourth Ave., Mt. Vernon, NY 10550.

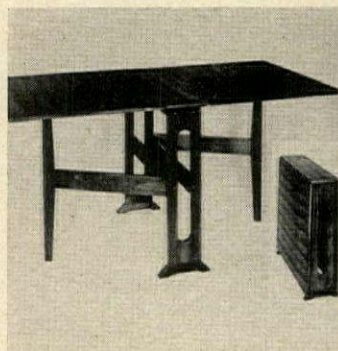

TO HAVE AND TO FOLD

Space saving table made in Europe of solid beechwood and finished with oiled walnut veneer. Closed, 9" by 30"; one side up, 37" by 30"; fully opened, 65" by 30" and it seats eight. 30" high. Perfect for apartments. \$47.95 exp. coll. Shipped assembled. Danish catalogue, 25c. Genada Imports, HG10, Box 204, Teaneck, NJ 07666.



UNDERSTATED BEAUTY

A Louÿs XV design doesn't have to dominate your décor. Its hand-carving and flowing line enchant and enrich any room. Yugoslavian beechwood frame, hand-caning. 37 1/2" h., 23 1/2" w., 17 1/2" d. Unfinished, \$79.95. For any wood finish, add \$25. Exp. coll. 128-pg. catalogue, \$1.50. Artistic Frame International Ltd., HG10, 407 E. 91 St., NY 10028.



sterling medallion

A stunning pendant or Christmas ornament
Only \$10.00

A gift in silver for so little! Tastefully designed by Towle in relief. . .with the 'peace dove' on one side, a 'partridge in a pear tree' on the back. Gift boxed. Add 25¢ for postage. Mass. residents add 3% sales tax.

Anderson's

JEWELERS AND SILVERSMITHS
21 Grove St., Wellesley, Mass. 02181

4 1/2 inches wide.

SHOPPING AROUND

GLASS WASHING WHIZ
Banish dishwashing, the party bugaboo, with the non-electric Carollette washer. Look through its clear dome as water and liquid detergent spray 24 items clean in five minutes. Hose snaps to faucet in home or office with adaptor included. Gold or avocado base. 13½" h., 18" dia., \$24.98 ppd. Collier's, GE-1071, Box 585, Skokie, IL 60076.

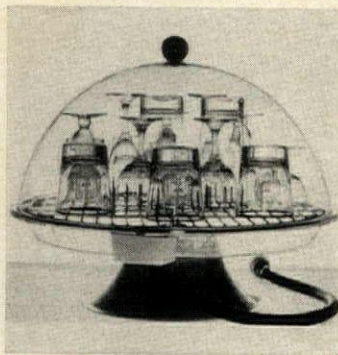

TAKE TIME
By guess and by golly just won't work when you time eggs, blend a soufflé. Neat little timer does the trick. And how about checking it on long distance phone calls? Walnut finished wood and just \$1.29 plus 20c post. Great little gift for the careful cook! Anthony Enterprises, HG10, 585 Market St., San Francisco, CA 94105.



PLUCKY PLAQUES
Right on for the young fry. Decorative, multi-color plaques of little football heroes are fair game for a child's own room or playroom. They're 8½" by 11¼", 9" by 12" and 8½" by 10¼". Set of three is \$15.95 plus 95c postage. Order now from Creative House, HG10, 221 W. 9th St., Kansas City, MO 64105.

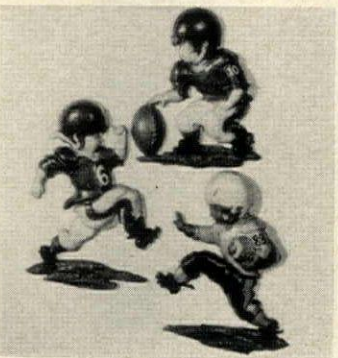

LET THERE BE A LIGHT
For emergency break glass! Smokers find puffs aplenty in the lonesome cigarette stashed behind the window. A likely spoof for any smoker or past-smoker you know (with a sense of humor). How about one for your party room? \$1.98 plus 30c post. from Anthony Enterprises, HG10, 585 Market St., San Francisco, CA 94105.

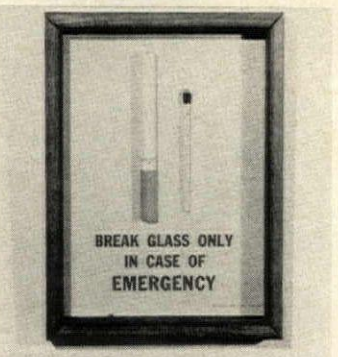

BETTER FOR BUTTER
Add sparkle to upcoming holiday galas with an elegant crystal butter dish. Reproduced from antique design, the 7" dia. dome reflects light from its many facets. Truly lovely by candlelight! Priced right for Christmas or wedding gift-giving at \$4.98 plus 85c post. Harriet Carter, Dept. 6300, Plymouth Meeting, PA 19462.

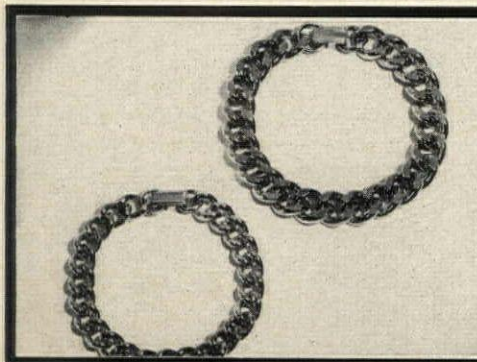

COPPER CURE-ALL?
We're not making any claims, but sportsmen, socialites and actors share the copper craze. They swear by some magic mumbo-jumbo, copper gives aches and pains the brush off.
Men's Copper Bracelet \$2.98
Women's Copper Bracelet \$1.98
Mailing 15c Each
Calif. residents add 5% sales tax.
Satisfaction guaranteed.
Anthony Enterprises
585 Market St., Dept. HG-101
San Francisco, Calif. 94105

CURTAIN CHARM

WITH RUFFLED UNBLEACHED MUSLIN

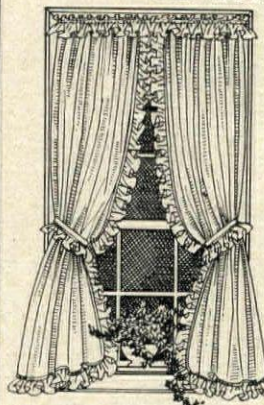

TIEBACK
45", 54", 63", 72"
long 5.00 pr.
81", 90" long
..... 5.50 pr.

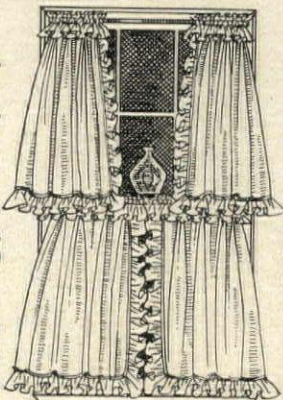

TIERS
20", 25", 30",
36", 40" long
..... 3.50 pr.
2 pairs to window as
shown 7.00

Both types 70"
wide per pair
MATCHING VALANCE
11" x 70" 1.75

Please add 50c to each
order for handling.

For years, New England housewives have made these charming UNBLEACHED MUSLIN curtains for every room in the house. COUNTRY CURTAINS makes them for you with all the original simplicity, warmth and handmade look. Practical, long-wearing, these unusually attractive curtains of old fashioned muslin retain their crisp appearance with a minimum of care.

Satisfaction guaranteed. Check or money order. No COD's please. Write for brochure showing full line of curtains in many styles and fabrics. Mass. res. add 3% sales tax.

COUNTRY CURTAINS AT THE RED LION INN
DEPT. 104, STOCKBRIDGE,
MASSACHUSETTS 01262

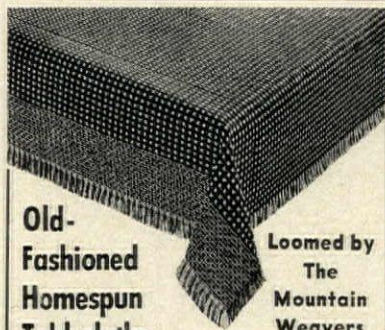

**Old-Fashioned
Homespun
Tablecloths**

Loomed by
The
Mountain
Weavers

Loomed in the Appalachian Mountains by mountain weavers, a skill handed down by their forefathers. Real homespun cotton in a host of marvelous sunny colors, these self-fringed tablecloths are reversible for double wear, washable, never touches an iron. In gold, red, blue, olive, brown and Sahara sand.

52" x 52" \$6.95 14" Sq. Napkins \$1.95 pr.
52" x 72" 9.95 12" x 18" Place Mats,
62" x 90" 12.95 \$2.50 pr.
62" x 108" 14.95
72" Round Tablecloth \$15.95
All prices ppd. Send 25c for catalog

Jenifer House Dept. G-101
GREAT BARRINGTON, MASS. 01230



YOUR PET SCULPTED IN BRONZE.
Handsome statuette is a permanent token of your favorite pet mounted on a block of Italian marble with a gold plaque featuring his name (or hers). Specify breed and name. Also available: Persian, Tabby, Siamese, Canary, Parakeet and any breed of horse. \$9.95 plus \$1 for shipping.
JAMAICA SILVERSMITH
Dept. HG-10
407 Rockaway Ave., Valley Stream, N.Y. 11581

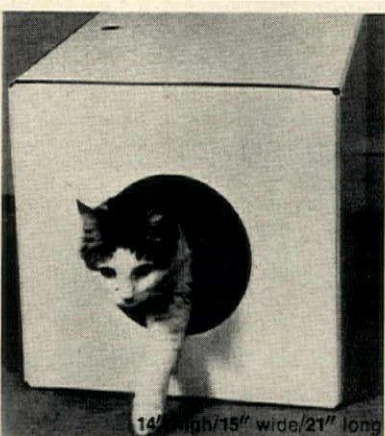

kat-trene®
A sophisticated enclosure to hide unsightly feline litter pans. Collects litter spillover/confines odors. Thick fiberboard/white/folds. Plastic coated inside & out.
\$4.98 postpaid (two for \$9.50)
(add \$1.00 ea. postage west of Miss.)
Personalized: \$1.00 a word/PRINT

Kat-trene Dept. HG10
P.O. Box 3056/Elmira, N.Y. 14905



Hand-Carved Coat of Arms & Family-Crest RINGS
Your own coat of arms hand-carved in wood painted in full color on 16"x13" wood shield \$ 45.00
Same coat of arms with Toledo swords 60.00
(other sizes available)
Your coat of arms hand-engraved on silver, framed on velvet, 6"x8" frame from 40.00
FAMILY CREST RINGS
Your coat of arms hand-engraved on silver ..\$ 45.00
hand-engraved on 18k gold 99.00
hand-engraved on precious stones, 18k gold setting (choice of stone: synthetic ruby, synthetic sapphire, topaz, quartz, amethyst, bloodstone, onyx, agate or lapis lazuli) 135.00
ALSO CUFF-LINKS—PENDANTS—TIE BARS & CHARMS
We also do fire-enameling.
Also available is a heraldic report painted on parchment paper for \$6.00 (which will be credited in full to any subsequent order).
If you already have a coat of arms, send us a drawing or description; otherwise we shall do the research for you. Send for free color catalogue.

HERALDICA IMPORTS Dept. G15
21 W. 46th St., New York, N.Y. 10036

Lady be good to your feet

Enjoy buying choice-quality shoes by mail from our world-famous catalog showing huge variety of smart styles for every occasion — and our vast size range insures perfect fit — or your money refunded!

Send for Free Catalog
SIZES 1 to 13 SHOES
AAAAA to EEEEE

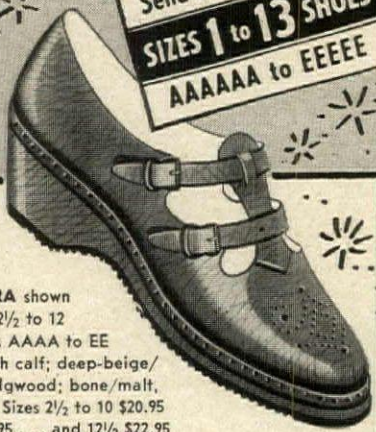
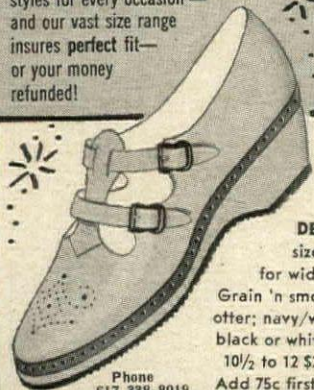

Phone 617-338-8019

DEBRA shown sizes 2½ to 12 for widths AAAA to EE
 Grain 'n smooth calf; deep-beige/offer; navy/wedgwood; bone/malt, black or white. Sizes 2½ to 10 \$20.95
 10½ to 12 \$21.95 . . . and 12½ \$22.95
 Add 75c first pair, 25c each additional pair for postage, please

SOLBY BAYES

45 Winter Street (Dept. HG) Boston, Mass. 02108

A CHILD AND HIS NAME

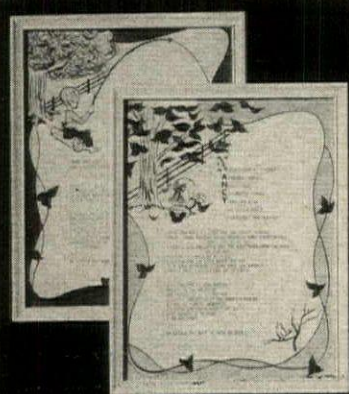

TRUE MEANING OF NAME WITH POEM IN A FRAME

A unique, personal gift! Tender, heart-warming poem is prepared expressly for your child with TRUE MEANING of your child's name. Blue design for boys, pink for girls. Framed under glass in an 8" x 10" white wood frame with hanger. Perfect for child's room or nursery. If nickname desired, state given name too. Limit number of letters to nine.

\$5.95—Two for \$11.50

Add 70c for postage and handling.

PERSONALIZED CHILDREN'S POEMS

Dept. G101, Garnet Lake Road
 Johnsburg, New York 12843

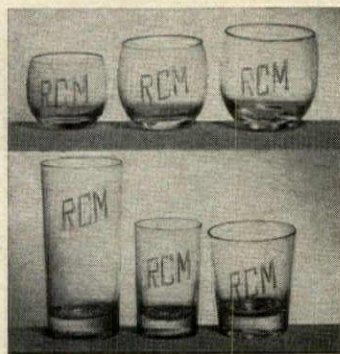

MONOGRAMMED GLASSWARE

For company or everyday use. Choose 5 oz.; 8 oz.; 11 oz. rolypoly with 5 oz. sham juice; 7 oz. old-fashioned; 12 oz. sham highball.

Set of eight **\$6.95** ppd.

Add 6% sales tax for Penna. deliveries

REIZENSTEIN'S

300-6th Avenue Bldg. Room 260-M
 Pittsburgh, Pa. 15222

"TRUNK REPAIR BOOK" plus FREE parts catalog!!!

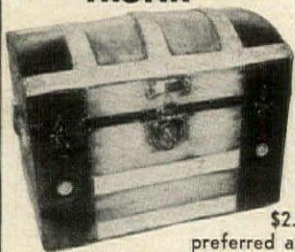

HOW TO DECORATE REPAIR AND RESTORE ANTIQUE TRUNKS

24 pages of easy-to-follow instructions and pictures. Over 20 years' experience. Cash in on the newest ANTIQUE and DECORATING craze from America's foremost "Trunk Repair Book" and the only complete trunk parts supplier.

\$2.00 postpaid or two copies for \$3.50 (if first class preferred add 35c each book.) REPAIR PARTS SENT DIRECT "FROM US TO YOU". Order direct from Antique Trunk Co.

ANTIQUÉ TRUNK CO.

3706 W. 169th Street
 Cleveland, Ohio 44111

THE Odorless CAT TOILET



Liquids filter through screen and evaporate. Litter stays dry and rarely needs changing. Ends messy disposal. Keeps cat's feet clean. Will pay for itself quickly in litter savings. Solids easily removed by wide scoop. Bigger, deeper, stronger than regular cat pans. Non-corrosive. One full pint deodorant with spray head furnished. \$7.95 plus \$1.50 postage. No C.O.D.'s.

SPECIAL PRODUCTS, Box HG 861, Traverse City, Mich. 49684

SHOPPING AROUND

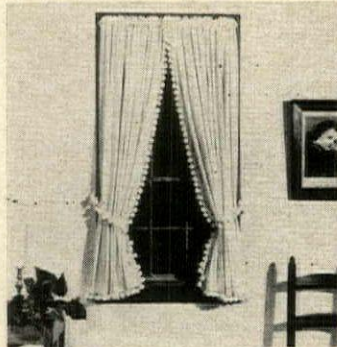

MUSLIN MANNER

Smart, simplistic curtains of unbleached muslin trimmed with a ball fringe suits windows wonderfully. *Giant* ball fringe tie-backs included. 80" w. per pr., 45", 54", 63", 72", \$7 pr.; 81", 90", \$8.50 pr. Smaller ball fringe, same sizes, same prices. Ppd. Add 50c handling per order. Country Curtains, HG10, Stockbridge, MA 01262.



BELIEVE IT OR NOT

This might be the perfect way to save for that proverbial rainy day. It's a knitted sock with a change purse clasp attached to the top. The sock is long enough to hold a trove of cash plus lots of loose change. \$1.98 plus 20c post. Anthony Enterprises, HG10, 585 Market St., San Francisco, CA 94105.



THE WHISTLER

Key control chain door alarm gives double protection. It has a sturdy chain plus an alarm that emits an ear-piercing sound if anyone tries to enter while the chain is on guard. Alarm has two keys. Battery operated; 3¾" by 3¾". \$11.95 plus \$1 post. Morlyn Inc., Dept. HG-101, 4900 Georgia Ave., West Palm Beach, FL 33405.



SUPER STONEWARE

Oven to freezer to table and how handsomely with hand-crafted stoneware. Oyster white splashed with daisies and green-toned leaves. Casserole: 3-qt., \$13.95; 1½ qt., \$9.95. Individual covered onion soup or mini casserole, \$4.95. 10" quiche pan, recipes, \$7.95. Ppd. Free brochure. Epicure's Boutique, HG10E, Box 446, Chatham, NJ 07928.

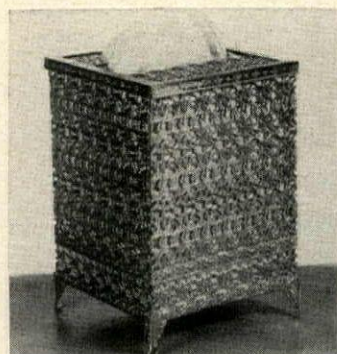

FAIR AND SQUARE

Striking the totally feminine note for boudoir or bath accessorizing, an elegant golden tissue box. Lovely, lacy 18k gold-plated metal topper and cover in new square shape to fit the popular boutique tissue boxes. 4½" sq. \$4.98 plus 35c postage. Lillian Vernon, GSO, 560 So. Third Ave., Mt. Vernon, NY 10550.



LINGERIE HOLDERS

Bra and slip straps stay put with lacy white fabric pads that slide on easily. No cutting, tenderness or drooping straps. One size fits everyone. No snaps, no fasteners. The shoulders stay smooth and comfortable. Order several pairs. Just \$1.69 a pair plus 15c post. Anthony Enterprises, HG10, 585 Market St., San Francisco, CA 94105.

SHOPPING AROUND

WHIZ-BANG WHISTLE

Kids always adore whistles. Here's one grown-ups love, too! Gleaming metal police whistle calls the dog, signals directions at games, even makes a perfect birthday party favor. A real traffic-stopper and completely safe. Only \$1—order several. Add 15c postage each. Anthony Enterprises, HG10, 585 Market St., San Francisco, CA 94105.

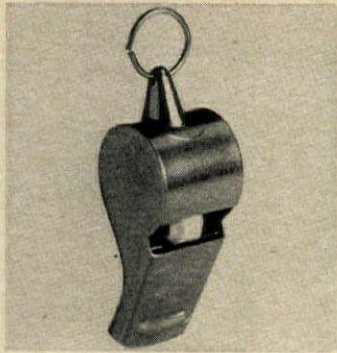

GARDEN DISPLAY

Six adjustable pine shelves spiral around a turned birch post to show off house plants or arrangements of cut flowers from the outdoor garden. A brass ring makes it portable to get the best light. 39" h. Honey tone pine or maple, antique pine or walnut finish. \$26.50 ppd. Add \$1 W. of Mississippi. Yield House, HG10, North Conway, NH 03860.

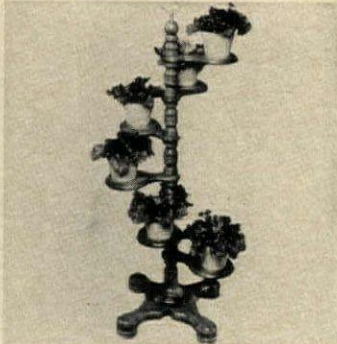

WRITE A WILL

Will Forms Kit helps you write a will and eliminates court and legal fees. Kit includes: four will forms, information forms and a guide to wills, a 64-page book on wills, duties of the executor and two blank forms for records of family assets. \$1.98 ppd. Order from Walter Drake, HG65, Drake Bldg., Colorado Springs, CO 80901.

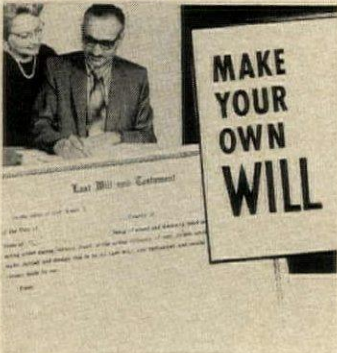

ANTIQUE MONTHLY

If you're an antiquer, you'll love every page of the current happenings in the antiques world. Up-to-date information on shows, exhibits—many photos in full color and lots of black and white illustrations, too. 68 to 72 pages. Special offer: 12 issues for \$4.99 ppd. Sample copy, 25c. Antique Monthly, HG10, P. O. Drawer 2, Tuscaloosa, AL 35401.



FOR STOCK WATCHERS!

You're an automatic expert with this handy stock market calculator. A fast flip of the dial tells total price, profit or loss, commission, break even cost. For any stock from \$1 to \$100 in share units 5 to 500. Outmodes pencil figuring, prevents errors. \$3.95 plus 50c post. Anthony Enterprises, HG10, 585 Market St., San Francisco, CA 94105.



SOUND APPROACH

Remember phonics lessons—learning to see sounds? The Sound Way to Easy Reading teaches your child the way we were taught. In about two weeks pupils read 300 new words. With the complete course a student can acquire up to a full grade's skill through charts and records. Free two week trial. Bremner-Davis, HG10, Wilmette, IL 60091.

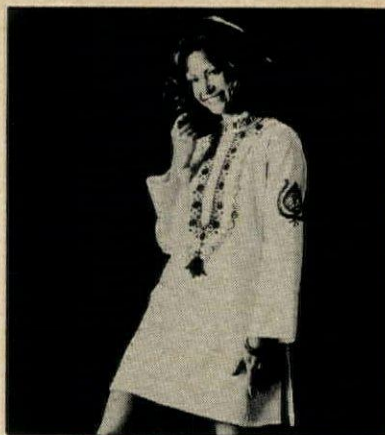

KURTA DRESS from Pakistan

For the casual hostess, comfort pairs up with style in this Kurta dress of cotton homespun. Natural color is hand embroidered in brown, blue, gold, or purple. One size fits all.

\$16.50 ppd.

Send 25c for our new 56-page catalogue of 600 imports.

• Visit our stores in Norwich, Vt. and Wellesley, Mass.



SHOPPING INTERNATIONAL, INC.
555 Shopping International Bldg.
Norwich, Vermont 05055



TILE TOP TABLES

Gay, colorful tiles from Spain are set into black wrought iron tables. Lightweight, portable tables are 18" high. The tiles, hand made in traditional Moorish patterns, no two alike, are 8" square. Colorful accent, handy table.

\$12.95 postpaid.

ELIZABETH McCAFFREY
Dept. HG 10T
Northport, New York 11766

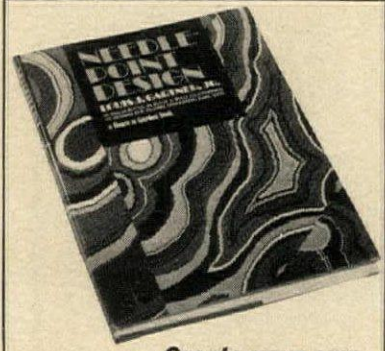

Create your own NEEDLEPOINT DESIGN

Learn how to make your own needlepoint designs. Fill your home with unique pillows, rugs, wall hangings, etc. It's fun when House & Garden editor Louis Gartner shows you how easy it is. This new, complete, hardbound book can save you up to 80% of the cost of your materials.

40 full-color pages, plus 83 black and white illustrations.

Satisfaction guaranteed.

Only \$15.95 ppd.

Sorry, no COD's.

CONDÉ NAST BOOKS
Dept. HG10, P.O. Box 3308
Grand Central Station, New York, N.Y. 10017

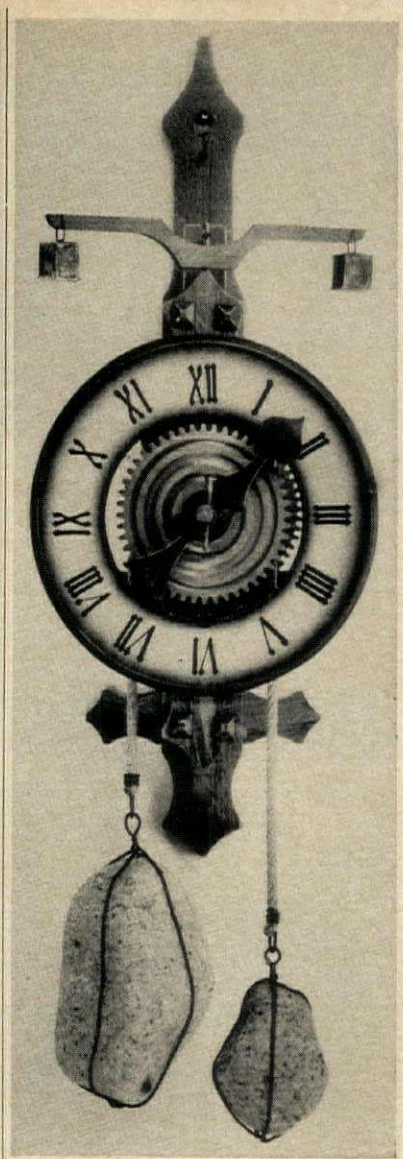

OLDE and NEW

This Kit—reproduction of a Gothic Wooden Wheel Clock from the 12. Century—consists of all the necessary parts: accurately machined and laminated gears, wood stain, sandpaper. Everything that's needed awaits your application of a little love and whatever stones you choose for counterweights.

The illustrated, detailed instruction booklet, enclosed with every kit, takes you step by step to a completed, functioning timepiece.

The only tools needed are: hammer, white glue, pliers, brush (and that little bit of love).

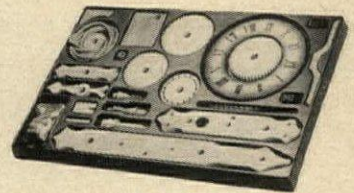

Finished clock dimensions: dial diameter 6.3 inches, frame height w/o stones 15 inches. Complete colorful catalogue 25 cents. Illustrated Kit E 146 sells for \$37, completely assembled Clock E 149 for \$47. Postpaid with your check. Money back guarantee.

HELD

9-2 Lakeview Drive
Farmington, Connecticut 06032

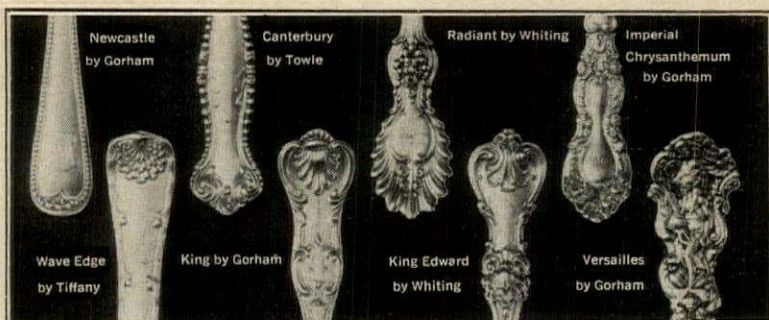

As Seen In HOUSE & GARDEN'S New Feature Column

PLEASE TELL ME

Do you know where I can buy discontinued silver patterns?

I recently inherited some silver and wonder if I might add to the set. I do not know the name of my pattern. Jeans Silversmiths Inc. carries hundreds of old and discontinued American Sterling patterns. Just send a snap shot, tissue rubbing, or xerox, with a description of any identifying marks. Jeans can identify your pattern from any of the above.

IF IT'S SILVER YOU WANT

JEAN'S SILVERSMITH'S INC.
16 W 45th St., N.Y. 36 N.Y. - OX 7-0367

SHOPPING AROUND



FROM THE NECK UP

Apply makeup any time, anywhere. Handy 5" mirror hangs lightly from your neck as well as on a wall. Regular on one side, magnifying on the other. Sturdy steel frame stands on dresser too. \$1.98 plus 20c post. Order #122 from Anthony Enterprises, HG10, 585 Market Street, San Francisco, CA 94105.



IN A WEATHER VEIN

To send and save, nineteenth-century postcards with a new twist: colors that change with the weather. Blue means fair; pink, rain; purple, variable conditions. As gay as the 90's and perfect for an easel frame. 4" by 6". Set of four, \$1.98 ppd. Order from Harriet Carter, Dept. 6302, Plymouth Meeting, PA 19462.



CHILDREN'S PRINTS

Introduce your child to art at an early age. "Children's Play Scenes" are miniatures printed on fine satin. They show the four seasons so charmingly we think the superb set would fascinate any child. Each print is 4 5/8" by 6 5/8", framed in antique gold-leaf. The set of four is \$24.75 ppd. Art Publishers, HG10, 18 E. Fourth St., Cincinnati, OH 45202.

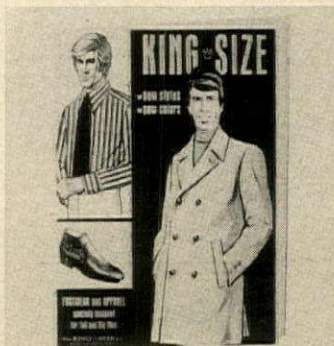

GIANTS' BONANZA

King-Size's Fall and Winter catalogue is now ready and it's free. 144 pages in color and everything is for the tall or big man. Includes famous brand jackets, shirts, sweaters, slacks of all shapes and fabrics, shoes and boots 10 to 16, AAA to EEE. Necks to 22"; waists to 60". King-Size Co., 4291 King-Size Bldg., Brockton, MA 02402.



CUT FOR ECOLOGY

Turning trash into treasure is right on in every community today when we're menaced on every side by environmental problems. One easy solution is the bottle cutter that turns no-return "throw-away" bottles into glasses, vases or bowls. Safe, easy-to-use metal cutter with instructions. \$11.98 ppd. Taylor Gifts, HG10, Wayne, PA 19087.

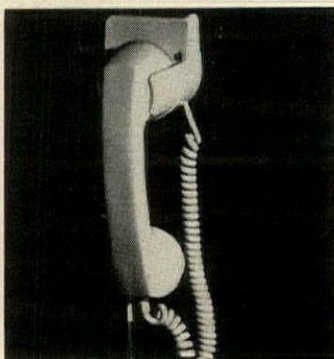

THRONE PHONE

What's the greatest bathroom luxury since bubble bath? A "Throne" extension phone! Relax and still catch all calls. L-o-n-g cord stretches for convenience; plug and cable install easily. Red, gray, black, green, white, beige and ivory. \$19.95 plus \$1.50 post., \$2 post. w. of Mississippi. Metropolitan Teletronics Corp., HG10, 35 W. 35th St., NY 10001.

STAIRWAY ELEVATOR SAVES YOUR HEART

Your STAIR-GLIDE will be shipped to you within 48 hours. Installs in less than two hours. No special wiring. No marring walls or stairway. Tax deductible when recommended by a physician. GUARANTEED.

Used by thousands: **CARDIAC PATIENTS • ARTHRITICS • POST OPERATIVES • SENIOR CITIZENS • PARALYTICS • RESTRICTED PHYSICAL ACTIVITIES.** Outdoor model also available.

Write for free brochure
AMERICAN STAIR-GLIDE CORP.
201 West 80th Terrace, Dept. HG-10
Kansas City, Missouri 64114

RENTAL-PURCHASE Plan Available

These beautiful words of love and truth are handpainted on a 5" x 7" wooden plaque with antique white background.

\$5.00 INCLUDING POSTAGE

Send .50 for our 1971 Christmas catalog of handpainted and handcrafted items for gifts and the home.

Originals By Mel
P. O. Box 6382-G
Corpus Christi, Texas 78411

BLOW YOURSELF UP

TO POSTER SIZE

Friends, relatives, babies, pet and cars, all make great giant Photo Posters. A great gift or gag idea. Ideal room decoration... Perfect for parties. Send any b&w or color photo, polaroid print, cartoon or magazine photo. Better originals produce better posters. Giant b&w poster mailed in tube.

2 FT. x 3 FT. \$3.50
1 1/2 x 2 Ft \$2.50 • 3 x 4 Ft \$7.50

RUSH SERVICE orders shipped in 1 day by first class mail. Add \$2 per poster ordered.

NEW Posters from ANY SLIDE OR NEGATIVE. Add \$1.00 per poster.

Your original returned undamaged. Add 50c for postage and handling for EACH item ordered. N.Y. residents add sales tax. Send check, cash or M.O. (No C.O.D.) to:

PHOTO POSTER INC.
Dept. HG1071, 210 E 23 St., N.Y. 10010

ROLLING PLANT STAND

Eliminates lifting, pulling, straining—
Ball-bearings roll heavy plants with ease

New Plant Caddy protects your floors and carpets from indentations, scratches, dirt and water spots. Permits you to simply roll plant to sink for watering. You can rotate plant for equal light distribution to assure even growth. Decorative platform with sturdy ball-bearing casters, measures 12" across, 3" high. Has a stain resistant walnut wood-grain top. **\$5.95 plus 75c postage.**

FERRY HOUSE Dept. GPS
Briarcliff Manor, N.Y. 10510

SHOPPING AROUND

WAKE-UP WATCH

Swiss alarm watch in a golden-tone case gives a gentle buzz to awaken you. Handy, too, for keeping appointments on time. Raised gilt numerals and minute markers. Unbreakable mainspring, anti-magnetic hairspring, luminous hands, lizard strap. \$14.98 plus \$1 post. Jay Norris Corp., Dept. QE-32, 31 Hanse Ave., Freeport, NY 11520.



WINGED HANDBAG

The perfect country handbag any time of the year or for travel to sunny climes, printed ecru cotton (great quality!) with a deft design of colorful birds on branches. 12 1/4" wide and 9 1/2" high with self-welted handles. Snap closure; stiffened bottom. \$6 ppd. Johnny Appleseed's, HG10, Box 706, Beverly, MA 01915.



LADY'S ROCKER

A most feminine mahogany reproduction is a copy of a Victorian original called Aunt Jodie's sewing rocker. The detailing is hand carved; the spring seat a comfort feature. 18 3/4" w., 35" h., 29 1/2" overall depth, \$79.95. Exp. coll. A selection of samples plus catalogue of Victorian furniture, \$1. Magnolia Hall, HG10, 726 Andover Dr., Atlanta, GA 30327.



FOUR AND CLEAR

A quartet of handy compartments for pastas and peas, coffee and cocoa. Fill it as you will and set it on the scene in kitchen or bath. Amber and white lucite (shown) or all clear. One-piece canister is 16 1/4" l., 12 1/2" w. deep. Slanted top measures 4 1/4" to 8 1/4" high. \$29.95 ppd. and worth it! Elizabeth McCaffrey, HG10, Northport, NY 11768.

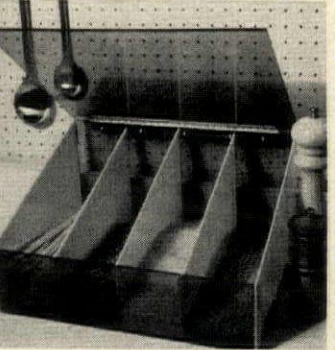

HERBAL EYE SOOTHERS

Eye pads, treated with a blend of European herbs and flowers, soothe eyelids and reduce puffiness beneath the eyes. Remove eye makeup, dip the pads in warm water, place them over closed eyes for 10 to 20 minutes. \$1.29 plus 15c post. Anthony Enterprises, HG10, 585 Market St., San Francisco, CA 94105.



ANGELS OF LIGHT

Bohemian glass kneeling angels sit on stars with candle holders in their arms. Heavenly on a holiday table with red or green candles, pine boughs and holly. Large, 5" h.; 4" dia., \$3.75 a pr. Small, 2 3/4" h., 2 1/4" dia., \$2.25 a pr. Add 50c a pr. post. Clymer's of Bucks County, HG10, Point Pleasant, PA 18950.

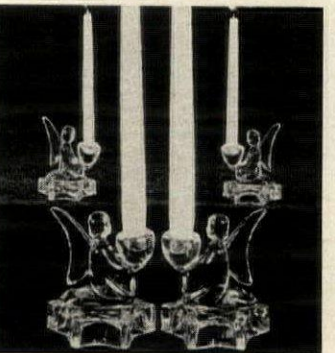

3 TROPICAL PALM TREES \$3

Extra Large! Up to 2 ft. Tall! Direct From Tropics!



These lush "Butterfly Palms" are available only through this ad. And there is a very limited supply. So order now! They bring exotic glamour to patio and garden in summer. Make ideal house plants in winter. "Butterfly Palms" are featured in HOME and GARDEN Magazines. Favored by top interior decorators and landscapers. Specimens can sell for up to \$10 and more. They thrive in sun or shade. Indoors or out with little care. Grows up to 6 ft. tall. Shipped direct from tropical nursery with simple instructions. Guaranteed to arrive in perfect condition or money back.

3 PALMS in a pot \$3 plus 50c pstg.
6 PALMS 2 pots \$5 plus 75c pstg.
9 PALMS 3 pots \$7 plus \$1 pstg.

Unconditional 30 day money back guaranteed

PALM NURSERY SALES Dept. HG-10
Box 383
Westport, Conn. 06880



The "Land of Aloha" proudly presents THE CAST IRON WOK

for the ultimate addition to your collection of cast iron cookware. After a long search our buyer located the source of the traditional cast iron wok, used for centuries by the Master Chefs of the Orient. Now you can combine the virtues of cast iron with the adventure of Oriental cookery. Made available at last to the West—exclusively from

12" diameter
\$16.95
postpaid
no cod's

House of Aloha

P.O. BOX 355
LA HAINA, MAUI
HAWAII 96761

HANDBLOWN CRYSTAL PUNCH SET

A perfect blend of contemporary styling and old world craftsmanship. This beautiful punch set will be the hub of attraction during any festive occasion. Hand crafted in old Mexico, the set features a handblown 15 quart bowl with hand polished ground rim, 12 matching handcrafted cups and matching handcrafted ladle. An unusual value at only \$24.95. Exp. charges collect.

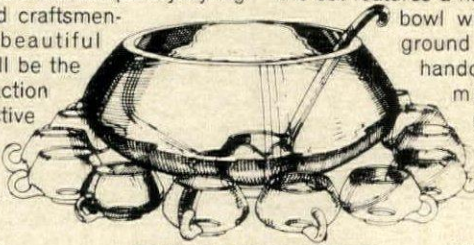

Sorry no COD's

JENSEN AND JENSEN

Satisfaction Guaranteed

Dept. HG10, 25455 York Road, Huntington Woods, Michigan 48070

Just in case...

the order form is missing from your

House & Garden

you may order with this

coupon ▼

House & Garden SUBSCRIPTION ORDER FORM

SEND ME

- 1 YEAR (12 ISSUES) FOR **\$7** (\$2 less than the 75¢-each newsstand cost)
 2 YEARS (24 ISSUES) FOR **\$12** (\$6 less than the newsstand cost)
 3 YEARS (36 ISSUES) FOR **\$16** (\$11 less than the newsstand cost; \$5 less than the cost of yearly renewal)

PLEASE BILL ME MY PAYMENT IS ENCLOSED

MAKE CHECK OR MONEY ORDER PAYABLE TO HOUSE & GARDEN.

(These rates limited to the U.S.A. and its Possessions; for Canada, add \$1 each year for extra postage. Elsewhere, House & Garden is \$9 a year.)

Name _____

(please print)

Address _____

Apt. _____

City _____

State _____

Zip _____

MAIL YOUR ORDER TO

House & Garden

BOX 5233
BOULDER, COLORADO 80302

**Radio Shack invents the
3-Piece Stereo Radio
that Looks Good
from any Viewpoint**

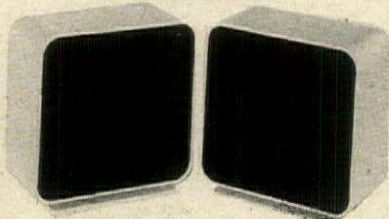
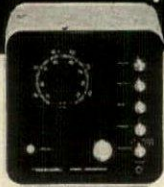

Molded speakers look great even from the back—Put them anywhere!

**REALISTIC
STEREO CONCERTMATE**

Only **89⁹⁵**

The first FM-AM radio to consider all points of view! Sleek, white cabinets, "black-out" front panel. Tuning dial glows green when radio is on. Tip of dial pointer glows red on FM-stereo stations. Place the wide-range speakers up to 10 feet apart to suit the room. Headphone jack for "private" stereo listening too. Each module, 8 1/2 x 9 1/2 x 6 1/4". You'll love it. At our over 1000 stores or by mail*.

**FREE
Catalog!**

*We'll ship anywhere in the USA postpaid. Add your state, local taxes if applicable.

ALLIED RADIO SHACK

A TANDY CORPORATION COMPANY

HG-2, 2725 West 7th Street
Fort Worth, Texas 76107

**MOIST HEAT
RELIEVES PAIN.**

The principle isn't new. Your grandmother dipped towels in boiling water, applied them to painful areas—and they worked. The THERMOPHORE® uses same principle without hot towels, scalding water. Large 27"x13" electric unit generates its own moisture, provides intense moist heat, relieves pain of arthritis, rheumatism, bursitis, muscle soreness . . . relieves misery of colds and flu. Two thermostats—uniform heat distribution. Automatic turn-off. 15 DAY FREE TRIAL. MAIL THIS COUPON, READ WHAT DOCTORS AND USERS SAY.



**BATTLE CREEK
EQUIPMENT COMPANY**
BATTLE CREEK, MICHIGAN

BATTLE CREEK Equipment Company
Dept. 25K, 307 West Jackson, Battle Creek, Mich. 49016
Please rush information on THERMOPHORE.

Name _____
Address _____
City _____ State _____ Zip _____

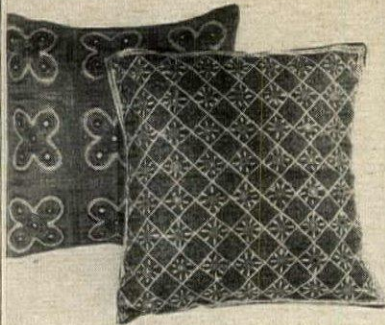

MIRRORWORK EMBROIDERY PILLOWS from India. Gleaming circles of tiny mirrors are embroidered on cloth in brilliant colors and designs. Entirely hand crafted, each design is individual. Luxurious, yet sturdy and practical. 16" x 16". Choice of red, green or black background; all colorfully embroidered.

\$9.95 plus 90c parcel post.

ELIZABETH McCaffrey
Dept. HG-10P, Northport, N. Y. 11768

**for your fine wood
furniture,
new and antique**

CLEANS, RESTORES, POLISHES,

PROTECTS. Permut WoodTreat is an emollient which pulls out grime and wax build-up, removes water spots, surface scratches, sun bleaching. It lets the natural lustre and texture glow through, providing a nutritive coating that stays in the wood's grain to prevent discoloration. It's easy and economical to use. Truly different. Money back guarantee.

Only **\$2.00** for 8 oz.
plus 50c handling
(\$2.50 total)

Permut Co.
Dept. HG 10
6880 Elbrook Ave.
Cincinnati, Ohio 45237

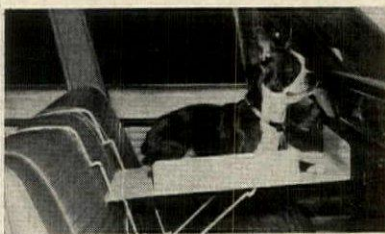

Auto Perch Pleases Pet

Your dog or cat rides in nylon-cushioned comfort, up where it can see. No distracting leaps on driver's arm. No "hairy" seats or smudged windows. Rails guard pet against sudden stops, turns.

Ready to hang on car-seat back, perch adjusts to best height and level. Generous 14 x 18" seat folds for easy removal. Strong metal coated in soft beige vinyl, nylon carpeted. You get a happy traveling companion or your money back.

\$13.98 plus 90c postage

GARRETT'S
Box 8415-59 Dallas, Texas 75205

SHOPPING AROUND



BRIGHT START

How better to start off a day at the office than with this cheery sign mounted on a wooden triangle 4" long by 2" h.? It's certain to bring all the guys and gals in to share in a good morning smile especially when the boss is in a Monday mood. \$1.98 plus 20c postage. Anthony Enterprises, HG10, 585 Market St., San Francisco, CA 94105.



GIDDYUP GEORGIE BOY

Profligacy of imagination here: Gaucho-type saddle seat to train a lad in the way he should go you know where. Adjustable clamp fits securely, perfectly on any size in the bathroom. New kick's made of high impact, washable plastic trimmed with western motif. \$3.98 plus 95c postage. Holiday Gifts, 310-E, 7047 Pecos St., Denver, CO 80221.

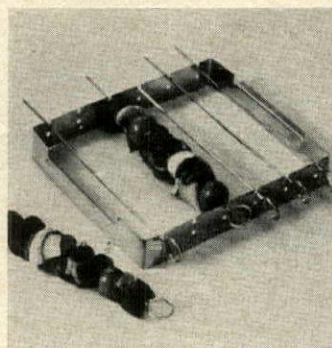

KEBAB PERFECTION

Chrome-plated steel shish-kebab frame with six skewers does ingredients to a turn in grill, hibachi or in the range broiler. Frame is notched to keep skewers evenly spaced. Skewers have ring handles for convenient turning; 10 1/2" long. \$1.98 plus 35c post. The Country Gourmet, Dept. GO, 545 4th Ave., Mt. Vernon, NY 10550.

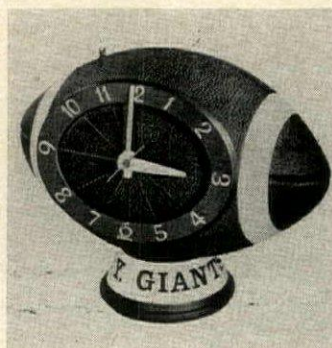

TIME, FELLAS

Football fans, it's that time of year and here's a realistic electric football clock in simulated pigskin. 10" l. and 7 1/2" h. Easy-to-read numerals and red sweep second hand. With adhesive backed team names. Desk model, \$12.95; wall model, \$9.95. Add \$1 post. Pegasus, Dept. HG10, 175 Lauman Lane, Hicksville, NY 11801.

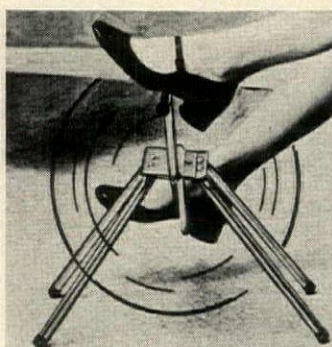

REST AND EXERCISE

The little tubular steel pedal cycle helps firm leg and thigh muscles and maintains slim legs and tummy as well. Sit down in a chair and relax as you pedal inches away and listen to TV or read. Adjustable for hard or soft pedaling. \$5.98 ppd. Walter Drake, HG41 Drake Bldg., Colorado Springs, CO 80901.



NEW ORLEANS TOAST

Original license issued by the city of New Orleans in 1881 to The Home of The Lewd Lady is printed on 13 oz. dishwasher-proof glasses. One, \$2.50; set of eight, \$14.95. Ppd. With a set of "infamous house" glasses goes a copy of the secret recipe for the Lewd Lady drink. J & D Enterprises, HG10, Box 23681, New Orleans, LA 70123.

SHOPPING AROUND

SHOWER ORGANIZER

Clear vinyl shower curtain liner is the answer to the family shower-time clutter problem. It has eight drain-dry pockets for soaps, shower caps, toys, lotions, brushes; helps to prevent dropping shampoo, soap. Magnetized bottom prevents billowing. \$3.95 ppd. West-Berg Enterprises, HG10, Box 4177, Colorado Springs, CO 80909.

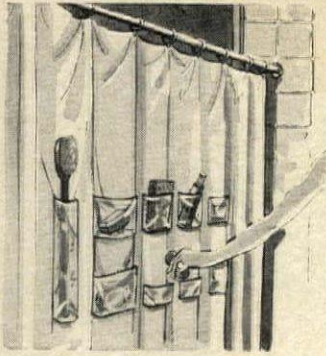

REPLACEMENT HOOD

Bonnets for portable hair dryers become tired so quickly, and replacements are hard to find. Wildflower pattern hood fits all table model dryers, attaches with a clamp and a turn on the hose. A new hood increases the dryer's life, too. \$2.98 plus 25c post. Anthony Enterprises, HG10, 585 Market St., San Francisco, CA 94105.



SERVICE FOR SILVER

Pamper your silver. Gorham does. Store it in this tarnish-proof, Pacific silvercloth pad. Converts drawer to silver chest. 11 3/4" by 15" by 2 1/2", holds over 100 pieces, \$5.95. 17 1/2" by 13 7/8" by 2 1/2", over 125 pieces, \$6.95. Add 75c post. Order from Barrington Specialties, HG10, Box 154-G, Barrington, RI 02806.



BLUE DENIM BANNER

Red, white and blue for '72! Herald the New Year with an all-American banner calendar. Cherry pie red pipes honest-to-goodness blue denim. Two brass eyelets let it all hang down in family room, kitchen or bedroom. A big 17" by 35 1/2" to see all of 1972 in a glance. \$4 ppd. from Miles Kimball, 100 Bond St., Oshkosh, WI 54901.

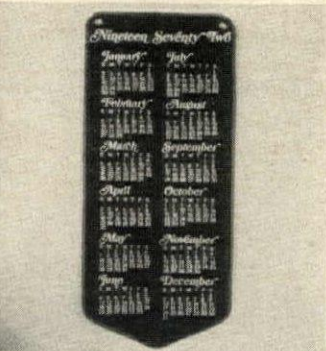

HAND-BLOWN CRANBERRY

The vibrant cranberry of fused gold and lead crystal is one of the great achievements of the glassblower's art. Hand-shaped 6" h. oval vase, or 8" h. vase are exquisite ornaments. \$13.50 each ppd. 78-page color catalogue of distinguished gifts, 50c. Sagittarius Enterprises, HG10, 315 Tenbytowne, Delran, NJ 08075.



PRIZED POSSESSIONS

Color catalogue is 20 pages of unique showcases for displaying and preserving personal collections: medals, spoons, watches, coins, antiques, trophies. Section on laminated plaques for diplomas and awards. Send \$1 (refunded with your first order). Award Maker, HG10, 12495 N.E. 8th Ave., No. Miami, FL 33161.



a rose by any other name
is still a rose, but a
diamond by any other
name is

THE KENYA GEM
...the only man-made
jewel that can be worn
side by side with a diamond.

Priced from \$45
per carat

Send for our
new free full
color booklet

KENYA DIVISION, DAY & FRICK, INC.
1760 N. Howard Street, Phila., Pa. 19122 • Dept. HG-10
Phone: (Area Code 215) 739-4080

1000 NAME & ADDRESS LABELS \$1

Finest quality name & address labels hand-somely printed. 1000 for \$1.00. Red, White & Blue American Flag Labels Deluxe quality 2" x 3/4" — 300 — \$2.00. Your personalized Horoscope Labels — Give name & address & Zodiac Sign for birthdate — 300 for \$1.50. Gold Labels 250 with 125 Initials set \$3.00. QUIK-STIK Self Adhesive Labels 500 for \$2.00. Deluxe size 2 x 3/4" 300 for \$2.50. Inc. 10c postage & 5% Ca. Tax. Write for money raising plan.



HANDY LABELS 1011 Jasperson Bldg., Culver City, Calif. 90230

THE IDEAL GIFT FOR ANYONE!!!

FIRST EASY-TO-USE GENEALOGY CHART
Make charting your family lineage easy and fun. Beautiful large 21" x 34" FAMILY TREE CHART is printed on quality heirloom antique parchment. Spaces are provided for up to 260 names of relatives arranged in proper relationship to one another so that anyone can see in a glance his family tree and all its branches. This chart provides a most rewarding, interesting, and educational hobby that results in an elegant document to be passed on and cherished for generations. A FAMILY TREE CHART is a must for keeping family lineage intact and up-to-date. The ideal gift for all—young or old, family or friends. A useful keepsake that lasts forever. Comes in its own heavy storage tube for permanent protection.
Only \$2.95 (plus 30c postage and handling)
Three for \$7.00 (plus 50c postage and handling)

FORMCO
POST OFFICE BOX 3828-C
LONG BEACH, CALIFORNIA 90803

RING YOUR CANDLESTICKS WITH CRYSTALIERS

Now you can add elegance to a plain candlestick. The nine hand-cut crystal glass prisms on a brass-color metal circle fit over the top of any candlestick catching and reflecting the tapers' radiance. Enhance any special occasion with their brilliance! Order for yourself... for gift giving. \$5.95 pair plus \$1.05 postage & handling. Sorry no C.O.D.'s. Satisfaction Guaranteed. Fla. residents add 4% sales tax. Write for Free Catalogue.

MORLYN INC. Dept. 6101
4900 Georgia Avenue
West Palm Beach, Florida 33405

INDIAN-LINCOLN CENTS BY THE POUND!

I'm selling my trunkful of cents from the 1860's thru the 1920's, 'grab-bag' style by the sack!

One pound \$10
Sample bag of 20 \$2

MRS. PENNY FISHER
Box 1778, Dept. HG, Encino, Calif. 91316



Your Own Pair of WOODEN SHOES

Beautifully finished, decorated and personalized. An unusual gift, delightful surprise, perfect conversation piece for living room or den. Useful as centerpieces, door stoppers, planters, etc. Made to actual shoe size by the suppliers of wooden shoes to "klompen dancers" of Holland's famous Tulip Festival. State shoe size (men's, women's, children's) and clearly print name for personalizing. Specially priced. Sent postpaid, money back guarantee.

Children's
Size 7 to 13 \$6.50
Men's or women's
Size 3 to 13 \$8.00

Write for Brochure
WOODEN SHOE FACTORY
Holland, Michigan 49423



Personalized Trivet

by F. B. Rogers

\$5.95
engraved

\$5
plain

A luxurious serving accessory... both functional and decorative, with your very own engraved initial. Keep your serving pieces with hot foods and beverages on this exquisite trivet to protect your table. 6" rhodium-finish trivet with see-through leaf and floral design; clear glass inset. Tarnish-resistant too. For your own dining table or as a thoughtful gift.

Mary Lib's Boutique
NEYHART'S INC.

145 West Third Street
Williamsport, PA 17701

Postpaid. PA residents add 6% sales tax.
25 page color catalog—available 25c.

SHOPPING AROUND

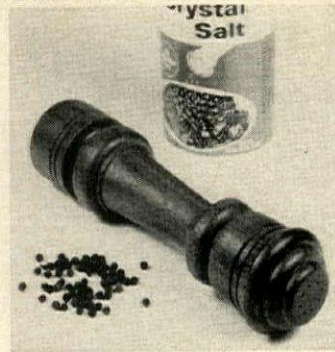

ZESTY COMBO

Kiln dried American walnut and case-hardened steel grinding mechanism team in a combination salt shaker and pepper mill. An elegant note for the dinner table. Easy to refill with both salt and pepper corns. 9" high; 2 1/4" dia. \$12.50 ppd. Block House Enterprises, HG10, Box 260, Bellport, NY 11713.

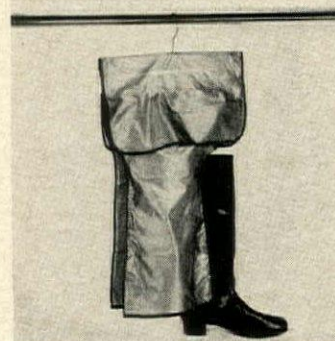

UPSIDE-DOWNER

Knowledgeable boot owners know that boots should be hung upside down to keep their shape, let them air. Gold-tone vinyl holder has snap-flaps at top to slip boot toes in, open bottom for air circulation. 23" long with hanging hook. \$1.49 each; three for \$3.98. Add 35c post. Write to Lillian Vernon, GO1, 560 So. 3rd Ave., Mt. Vernon, NY 10550.

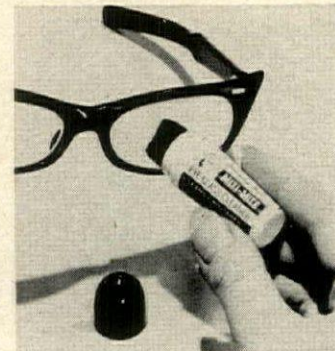

VIEW FINDER

Smudges wipe clear in a jiffy and glasses sparkle all day with just one application of magic cleaner. Handy pocket vial of sturdy plastic has applicator, gives hundreds of cleanings. Just dab on and wipe with tissue or handkerchief. Helps prevent fogging. \$1 ppd. Anthony Enterprises, HG10, 585 Market Street, San Francisco, CA 94105.

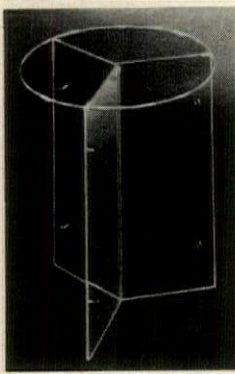

Decorate beautifully at half the cost! New booklet tells "how to" with PLEXIGLAS acrylic sheet

Our new colorful booklet shows how you can make transparent "see-through" furnishings with tough Plexiglas—at about 1/2 the cost of buying them ready-made—40 projects including lamps, cubes, wine rack, tables, kitchen accessories—illustrated, easy to follow instructions.

Also use Plexiglas to replace broken glass—it's the first plastic approved under new state safety window laws.

SEND 25c FOR POSTAGE AND HANDLING TO: ROHM AND HAAS COMPANY, BOX 9860B PHILADELPHIA, PA. 19140



CHOICE GIFT



SCULPTURED WEEDEPOTS

In beautifully grained hardwoods. They are small sculptures in their own right or use them to display that interesting dry plant life you have discovered. New catalogue of contemporary home accessories and jewelry 25c.

- A. 6" Tall walnut \$3.25
- B. Light oak 2" x 2" 3.75
- C. Wide low walnut 2" x 4" 5.95
- D. Mahogany, 4 1/4" high 4.95

Add 50c shipping for each.

Satisfaction guaranteed.

Discovery House

Dept. HG, P.O. Box 11561, Albuquerque, N.M. 87112

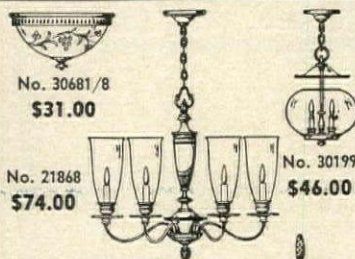

No. 30681/8
\$31.00

No. 21868
\$74.00

No. 30199
\$46.00

HAND MADE, SOLID BRASS LIGHTING FIXTURES

Made in our own shop since 1897. Available in pewter, polished or antique brass or silver. We also make tin lanterns, sconces and chandeliers. Wide selection, not available elsewhere. The hanging bowl is 8 in. The chandelier is 20 in. The ceiling light is 8 in. The coach lamp is 26 in. high. We also refinish and restore old lighting fixtures, lamps, lanterns, No. 17503 etc. We also supply missing glass parts. \$71.50

SEND 25c FOR 196 PAGE CATALOG

WILLIAM Spencer

RANCOCAS WOODS, N. J. 08060
Telephone 609-235-1830



CHARMS 'N TREASURES

Looking through the 140-page color catalogue took us well over an hour and every minute was fascinating. There are charms galore, including state seals, college emblems, zodiac symbols, religious, holiday and special occasions. Pins, necklaces, bracelets, too. \$1 ppd. Charm & Treasure, HG10, 72 Bowery, New York, NY 10013.



SCENT-SATIONAL

Delightful air freshener—decorative Perm-A-Scent wall vases turn stale room odors into sheer ambrosia. Fragrance is released—continuously. With French floral, lily (shown) or ribbed vase. Gift set: any vase with four months' supply of trefle or blue spruce fragrance, \$3.95 ppd. Edco Fragrance, HG10, 17-30 166 St., Whitestone, NY 11357.

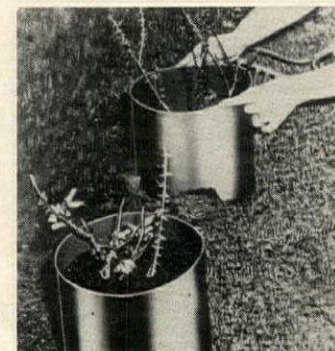

ROSE COLLAR

Bed down your roses and keep them snug and warm for the winter. Your reward? Prize-blooming bushes in the Spring. Herculite rose collars of kraft board with green weatherproof plastic, encircle the main stem to form a mulch container, 7 1/2" h., 12" dia. Perforated for drainage. Six, \$2.49 plus 35c post. Hanover House, Z-156, Hanover, PA 17331.

**BUY
UNITED STATES
SAVINGS BONDS**

SHOPPING AROUND

SKIN SMOOTHER

Scented cosmetic pumice stone does wonders in smoothing skin from elbows, knees, heels and toes—any part of the body that has become dry and calloused. Use it following bath or shower and skin becomes soft and velvety. \$1.98 plus 20c post. Anthony Enterprises, HG10, 585 Market St., San Francisco, CA 94105.



CHILDHOOD CHARMERS

Any child's name (up to 9 letters) and delightful print on rough-hewn wood. Color print of chore boy/girl, on blue; Sunday boy/girl, on yellow; girl and cat/farmboy on lime. 8" by 15". \$6.25 each; two, \$11. Add 60c post. Send 50c for color brochure. Specify name. Village Wood Shop, P. O. Box 645-H101, Englishtown, NJ 07726.

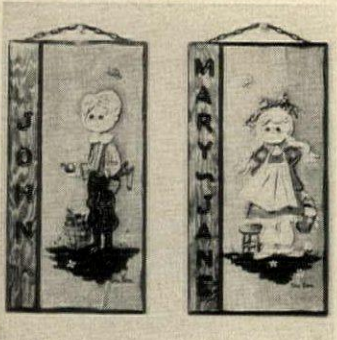

NEW TIMER

The beauty of this random timer is that it turns lights on and off at irregular times, simulating the normal "at home" look. The 24-hour unit is nicely styled in dark brown wood grain, has 125 volts, 15 amps, 1875 watt capacity. May be used to turn on appliances, too. \$12.98; two, \$25.75. Ppd. Collier's, HG10, Box 585, Skokie, IL 60076.



BRIQUET SAFETY BANK

When autumn cookouts are over, store half-burned charcoal briquets in matte black briquet bank with its own little shovel for absolute safety. On your next outdoor cooking occasion, half-used briquets are easy to start. 8" high; 6½" dia.; one gallon capacity. \$3.75 plus 75c post. Order from House of Minnel, HG10, Deerpath Rd., Batavia, IL 60510.



AMERICAN ACCENT

Anything ethnic's chic, and patchwork warms a room with homespun comfort that's Appalachia's own. Dandy for duds! Washable, perma-press cotton comes in any colors you wish. Specify four colors and get 16 samples for 10c. 45" w. fabric. 4" sq., \$6.25 yd.; 2" sq., \$8 yd. Ppd. Appalachian Trails, HG10, Box 247, Arlington, VA 22210.



PACKAGED SUNSHINE

You may not be able to pick 'em but you sure can squeeze 'em right from Florida. Treat yourself to these sweet, succulent oranges and grapefruits. Guaranteed excellence and delivery. Gift certificates are available. Free colorful folder lists prices in specific areas. A great gift in any season! Waverly Growers, HG10, Waverly, FL 33877.

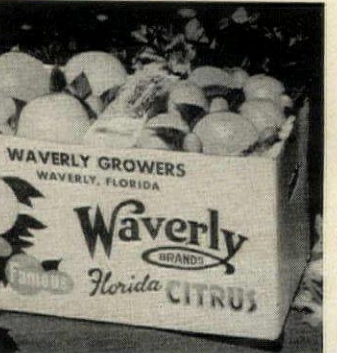

Lazy Susan

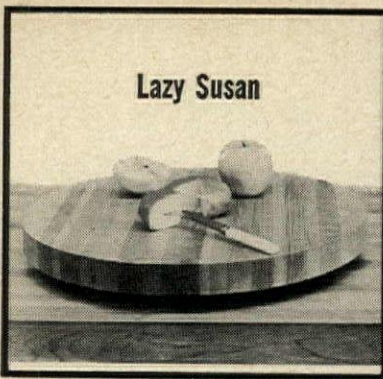

THE BUTCHER BLOCK

You've never seen a lazy susan like this one. 1½"-thick Butcher Block, turns quickly and easily on ball-bearing base. A handsome revolving cheese board, a great work-and-turn cutting board, or a convenient lazy susan for your dining table. 16" diam., \$19.90. 18" diam., \$24.50.

Order direct. Check or Money Order. No C.O.D.'s. Express charges collect. NYC, 7% tax. Elsewhere in N.Y. State taxes applicable. Catalog, 50¢

J&D Brauner

298 Bowery, N.Y., N.Y. 10012 GR 7-2830

ELEGANT HAREM RING

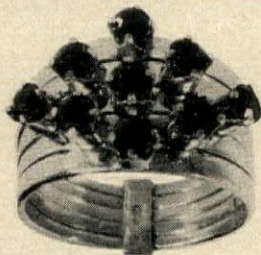

Lovely five-banded ring with 9 genuine precious stones—your choice of rubies, blue sapphires or opals—hand-set by skilled Thai craftsmen in a simple, distinctive 14 karat gold setting. A legendary gift of love to delight the most sophisticated—especially for Christmas!

And notice this guarantee—your money readily refunded if your appraisal value is not at least double this price of \$38 Ppd.

Please include ring size and choice of stone, and send check or money order to:

the DYNASTY

Dept. D101, 3203 Bader Ave., Cleveland, Ohio 44109

IMPORTED VELVET KAFTANS

Great for brilliant occasions! Mirror magic in the maxi mood... a long glamorous sweep of lush velvet delicately embroidered and accented with tiny mirrors. Super-smart in vibrant Red, Purple, Blue, Gold or Black. Sizes: S, M and L. DIRECT IMPORT PRICE: \$34.95. To-The-Knee-Length: \$24.95.



AZUMA

HG-10, 415 Fifth Ave., NYC 10016
Add \$1 for shipping & tax if applicable

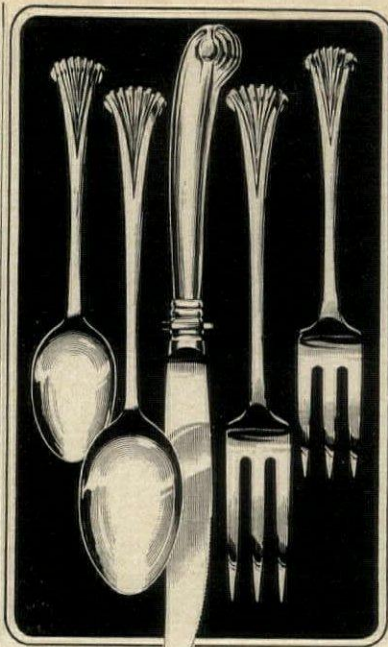

"George II"

Elegance on a budget

Glowing stainless replicas of the silver that graced the tables of 18th Century England's nobility.

50 piece service for 8... \$29.99
74 piece service for 12... \$44.99

Service for 8 with hollow-handled pistol grip knives, 3-tine forks, authentic extra large size pieces. Includes eight 5 piece place settings, eight extra teaspoons, butter knife and sugar spoon.

(Available in 24 karat gold electroplate at \$54.99 for the 50 piece service and \$79.99 for the 74 piece service.)

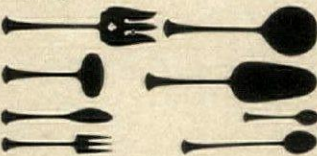

Also available:

Cold Meat Fork \$1.25 Salad/Berry Spoon \$1.25
Gravy Ladle \$1.25 Cake Server \$1.25
Butter Spreader 50¢ Demitasse Spoon 50¢
Cocktail Fork 50¢ Iced Tea Spoon 50¢

Your satisfaction guaranteed or your money will be refunded.

All shipments prepaid by us.

fortunoff

P.O. Box 132A, Westbury, New York

BLOW YOURSELF UP

ONLY \$3



Send us any original black & white or color photo up to 8" x 10" for best results (no negatives). Original returned unharmed with poster. Send check or money order. For prompt delivery, put name and address on back of photo.

2 ft. x 3 ft. \$3.00
1½ ft. x 2 ft. \$2.00
3 ft. x 4 ft. \$7.00
Frames: fit up to 2 ft. x 3 ft. \$3.00

plus 50¢ ea. postage, handling. Sorry no COPI's. Satisfaction Guaranteed.

The Blow Yourself Up Co.
Dept. HG-101
663 Fifth Ave. New York, N.Y. 10022

CATALOG



**DOGGIE
SNOW
SUIT**

Tames Winter!

Keeps your doggie toasty warm on icy, windy days! Made of gay red orlon pile with knitted, adjustable cuffs. Detachable hood. Full length zippers down back and under chest for easy-on, easy-off! Measure pet from base of neck to tail. Satisfaction assured!

SIZES 10 thru 16—\$9.95*

SIZES 18 & 20—\$12.95* (*Add 50c postage)

★ EVERYTHING FOR PAMPERED PETS!

Write for FREE 1971 catalog of the latest in pet wearing apparel, pet gift ideas, grooming needs, fancy collars, treats and many other new and unusual accessories.



(Famous for Pet
Furnishings
Since 1928)



DEPT. HG-10, P.O. BOX 24407,
NEW ORLEANS, LA. 70124



TIFFANY LAMP KIT

Now, as a result of our new novel forming technique, it is fun and easy for you to assemble this choice tiffany decorator lamp. Everything is included in the kit but the two hours of your time necessary for completion. The resurgent interest in this lamp style makes this true 22 inch diameter tiffany lamp, with electrical components, an unheard of value. Hard acrylic base undistinguishable from glass. **\$16.95**

Enclose 50c for postage

World Arts

Box 577-K, WILMINGTON, CALIFORNIA 90744

SHOPPING AROUND

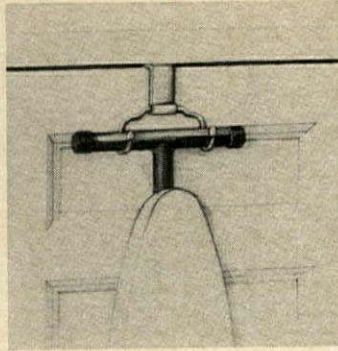

SAFE AND EASY

Ironing board holder hangs over door or mounts on wall in your ironing area. Board's stand slips over two hooks out of the way. Prevents cupboard tangle and accidents, yet ironing board is always handy. \$1.49 plus 25c post. Order from Anthony Enterprises, HG10, 585 Market St., San Francisco, CA 94105.



LAVISHLY LEISURELY

Dear little mules that stubbornly refuse to look anything but great with loungewear. Golden "kid" heel, delicate net upper, yellow-flowered terry sole. Comfort and femininity to step into the second you're home from a busy job or a round of shopping. Sizes 6 to 10. \$4.95 ppd. Order now from Elizabeth McCaffrey, HG10, Northport, NY 11768.

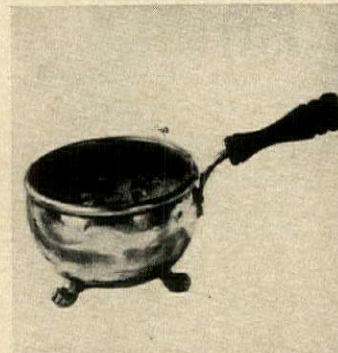

WARMING TREND

Pipkins, warming pots, dippers—call them what you will—charming gifts, perfect snack servers or sauce holders and decorative as little posy planters. They're 4 1/2" high, \$4.95 in copper, \$5.25 brass. Add 50c post. Order from Baxwood Crafters, Dept. PHG-10, 1171 Commercial Dr., Lexington, KY 40505.

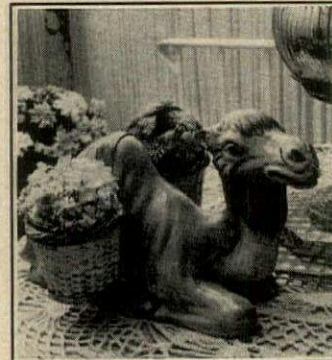

A CARAVAN OF IDEAS

Wouldn't he beguile you laden with flowers or plants, carrot sticks or spring onions, your small needlework—or—heaven forbid—even cigarettes? Camel, natural color; baskets trimmed pale green or yellow. Ours alone.

15 1/2 x 7 45.00 ppd.

16 1/2 x 8 55.00 ppd.

R.P. Robinson Inc.

1290 Third Street South, Naples, Florida 33940
Delray Beach, Fla. Petoskey, Mich.

**TAPESTRIES
FROM BELGIUM & FRANCE**



#226 Wagon Wheel 20" x 20" \$6.00
Add 75c for postage & insurance

DIRECT FROM EUROPE
—Save 80% to 90%—

Tapestries have been admired in Europe for centuries. At these low prices, you'll want several. Authentic replicas, machine woven of 100% cotton—will not fade. Sizes & scenes to fit any decor.

Send 60c for color brochure.

LOVELIA ENTERPRISES, INC.
Box 1845HG Grand Central Station
New York, N. Y. 10017

DESIGN YOUR OWN HOME OR OFFICE

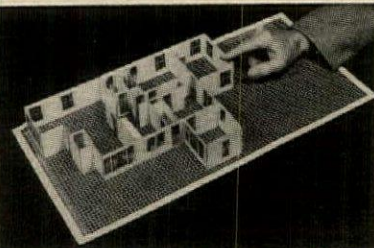

HOME-A-MINUTE KIT

- Try out ideas for building or remodeling
- Assemble walls, doors, cabinets & windows
- Build 3-D model to 3/4" blueprint scale
- Dismantle and rebuild plans in minutes
- Plan each floor of a multiple story bldg.
- Estimate costs/65-page handbook included
- Obtain financing and do own contracting

Satisfaction Guaranteed—Send \$3.95
plus 40c postage and handling to

LEE-VI COMPANY

P.O. Box 103M
11329 Melciare Drive, Beltsville, Md. 20705



TOTABLE DESK

Walnut look high-density plastic desk is a joy for readers and writers in bed. Great convenience, too, on chair, car, train or plane seat to work in ideal comfort. Legs fold in for portability. 13 1/2" by 19 1/2". Weighs 3 lbs. Perfect for sick child's games. \$8.98 plus \$1 post. Jay Norris Corp., Dept. QE-35, 31 Hanse Ave., Freeport, NY 11520.



UP, UP AWAY

Everybody's going places these days. Why not make a travel career work for you? As a professional tour director on free-lance assignments, the hows of dealing with airlines, hotels, agencies net you profitable expertise. For free "Travel Career Kit" write to North American School of Travel, Dept. HGP, 4500 Campus Dr., Newport Beach, CA 92663.



A WISE LOOKING BIRD

A very colorful Owl in bisque, perched on a tree branch, approx. 6 in. high. A conversation piece for any room.

\$2.95 each

plus 30c handling and postage.

DANIEL'S GIFT COMPANY

P.O. Box 8632
Detroit, Mich. 48224



MUSIC MASTER

"How To Read Music In One Evening!" cuts learning time from months to hours. A method that eliminates agonizing practice sessions and costly lessons. Book reduces music to the three basic elements: melody, rhythm and harmony; \$2.95 plus 25c post. J. W. Holst, Inc., Dept. GO, 1005 E. Bay, East Tawas, MI 48730.

SHOPPING AROUND

PICK A PINAFORE

Chief charm of the pinafore—it looks as great on big girls as little ones. Full-flared and criss-crossed at the back with ruffled wings. A winsome winner in Victorian print on a red or black background, red or navy gingham or blue or pink seersucker. Machine washable cotton. S, M, L. \$16.95 ppd. J. Jill Ltd., HG-101, Southfield, MA 01259.



ALOHA WOODROSE KIT

An exotic fragment of Hawaii transplanted to the mainland. Lovely Hawaiian woodrose dried a rich golden brown and made into a kit, for an everlastingly beautiful fall floral arrangement. 12" high assembled. Coconut shell base included. \$8.95 ppd. Free brochure of other kits. House of Aloha, HG10, Box 355, Lahaina, Maui, HI 96761.

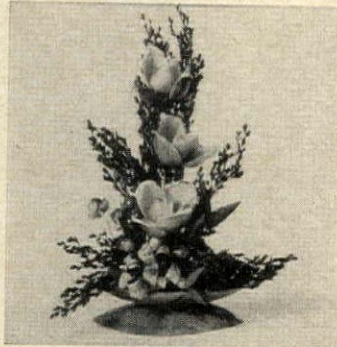

PERSIAN GEOMETRY

Needlepoint giant pillow, 20" by 20", is ready to stitch in a traditional Persian pattern of geometric designs. Colors are: gold, white, orange, green, red, and purple. Kit includes 10-mesh canvas, tapestry yarn, needle and instructions. Kit, \$15.95 plus \$1 postage. The Stitchery, HG10, Wellesley Hills, MA 02181.

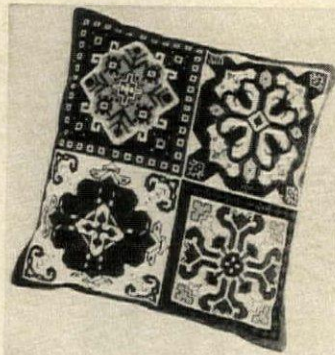

SPEC-TACULAR

For anyone *sportif*—stretch eyeglass band to keep those specs on during the action (your tennis, Jack's football, Jill's ballet). Thermo elastic adjusts to all sizes, washes easily, fits snugly and comfortably. No irritating odors or pinching metal. \$1.25 plus 15c post. Anthony Enterprises, HG10, 585 Market St., San Francisco, CA 94105.



THE BIG PICTURE

The subject is you; the size is super—two feet by three feet for only \$3.95. Hang yours in the dorm, Dad's office, on the home scene. Send any black and white or color photo to be returned as a black and white poster in a tube. 1½' by 2', \$2.95; 3' by 4', \$7.95. Ppd. Photo Poster, Dept. HG10, 210 E. 23rd St., New York, NY 10010.



LIKE THE REAL THING

Vega is one of the brightest stars shining in the heavens and the Vega man-made gem is pure white brilliance. Each crystalline stone with 58 facets expertly cut and polished. Won't scratch, chip or discolor. \$22 per carat. Free booklet includes styles for men and women on request. Vega Co., HG10, Box 465, Radio City Station, New York, NY 10019.



BIRD FOR ALL SEASONS

Authentic hunt club lamp—just the decorator touch for his den, family room or office. True duck sculptures, wood-based, 19" x 16½", in four choices—weathered driftwood effect, old world olive, brick red or walnut, each with oval burlap shade in complementary color. At this price consider buying several for distinctive Christmas giving!

SEND CHECK OR TRULY MONEY ORDER **A BUY!** \$19.95 PPD.

NEWBURY FARMS
12380 KINSMAN ROAD
NEWBURY, OHIO 44065



High Low Lavalier... the magnificent convertible!

Exquisite hardly begins to describe this stunning necklace with its arresting center crescent graced with 5 replicas of stickpin tops, bejeweled with simulated pearls, turquoise and amethyst. Antique gold finish. Inside chain is 24" long—outside chain 35". Swivel-attached crescent can be readily replaced with your own watch.

Style No. 309 • \$6.00 Postpaid
Send 25¢ for new Antique Jewelry Catalog.

Bonnie Sue Gifts

Dept. HG201, P.O. Box 253
Oceanside, New York 11572

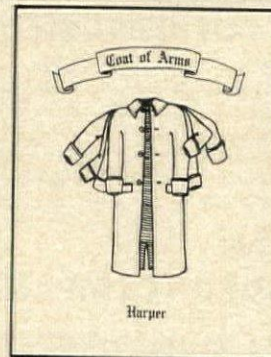

HUMOROUS COAT-OF-ARMS

Now anyone can proudly display a coat-of-arms, regardless of ancestry. Use in recreation room, office or den. Printed in black and bright red. Size 7" x 9". Please print name desired. All orders mailed within 48 hours. You may enclose gift card.

Unframed \$2.00 Postpaid
Framed \$3.00 "

SYLVAN STUDIO

P. O. Box 59 H, Sylvania, Ohio 43560

CHRISTMAS PLATES FOR CHRISTMAS GIVING

When you give one of the well-known Christmas Plates, you give a gift that will be enjoyed for years, and one that will increase in value as the years go by. Kaiser 1971 Plate (plate at top), "Silent Night", \$13.50 ppd. Royal Copenhagen 1971 Plate (plate in center), "Hare in Winter", \$15.00 ppd. Bing & Grondahl 1971 Plate (plate at bottom), "Christmas at Home", \$15.00 ppd. Write today for our complete list of available Christmas Plates as well as our other collectibles.



Viking Import House, Inc.



Dept. G-2, 412 S.E. 6th St.
Ft. Lauderdale, Fla. 33301



AT LAST ... A LOW COST PAINTING COURSE THAT WORKS!

PAINT FOR FUN OR PROFIT, WHETHER YOU CAN DRAW OR NOT! The American Masters Painting Course will help you become an accomplished artist. Five information-packed lessons and 25 helpful color slides cover all you need to know about materials, composition and color. Slides demonstrate color mixing, still life and landscape techniques step-by-step. Complete self-teaching course can be yours for ONLY \$49.95. Makes a meaningful, lifelong gift, too. **SATISFACTION GUARANTEED!**

AMERICAN MASTERS SCHOOL OF ART • Box 1121C • Redlands, Ca. 92373

- Send Oil Painting Course — \$49.95 enclosed (Satisfaction guaranteed)
- Send Deluxe Slide Viewer — \$11.95 extra enclosed
- Please Send More Information

Name _____
Street _____
City _____ State _____ Zip _____



Huasteca culture, ca. 1200 A.D.

OWN A BIT OF HISTORY!

Authentic Pre-Columbian Artifacts
Embedded in 2" lucite cubes

History buffs will love having a tabletop chard to display—eclectics will have an unusual decorative item. All Pre-Columbian pieces certified as to authenticity and carry a Certificate of Verification as to culture, date and location. **These are not reproductions.** Sold in better stores for more. No COD's. Texas residents add sales tax.

\$13.95 ppd.
2 for \$25.00

R. LARY KUEHN DESIGNS
4412 Southwestern Blvd., Dallas, Texas 75225



Attention Art Lovers!

Original signed Wood-Engraving by one of America's outstanding print-makers; G. Bernard Bishop. Limited edition, hand-printed on German paper. Shipped matted.

\$14.50 ppd.

RAVEN STUDIOS

1621 N. Vassar
Wichita, Kansas 67208

So Very Giftable!

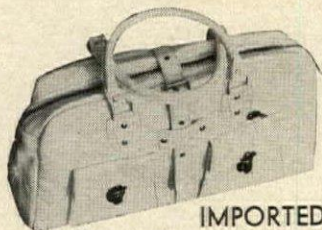

IMPORTED BEIRUT BAG

Glove-Soft Genuine Leather

From the fascinating "city of intrigue" comes a handbag that's as utilitarian as it is eye-catching. Big and not-so-big pockets inside and out hold everything in its own place; safely tucked away. Fashioned of finest leathers with care that typifies old world craftsmanship. Roomy 14x8" size just \$12.95. Compact 10x6" size. \$8.95. Specify first and second color choices: white, tan, beige, brown, black, gray or navy.

ORDER TODAY

Send check or money order plus 50c for postage and handling. Sorry, no COD's. We ship immediately. Money back guarantee of satisfaction.

Exclusively Imported By

GEAGEA ENTERPRISES

1365 E. Larned #203, Detroit, Mich. 48207

SHOPPING AROUND

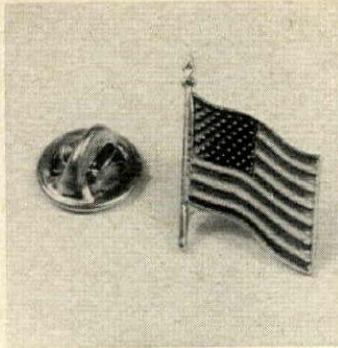

RED, WHITE AND BLUE

Men proclaim their allegiance with an enamel lapel pin of our flag. Veterans and all proud Americans wear the handsome pin on business suits and sports jackets all across the land and on travels throughout the world. \$1.98 plus 15c postage. Anthony Enterprises, HG10, 585 Market St., San Francisco, CA 94105.



JUMPIN' JIMINY

When we were kids, little girls jumped rope, but not boys! Now everyone is in the act for sensible exercise and muscle-firming. Jump rope, adjustable up to 94" long has an automatic counter in handle for controlled jumping exercise plus fun. \$3.49 plus 25c post. Holly House, HG10, 9924 Edgecove, Dallas, TX 75238.

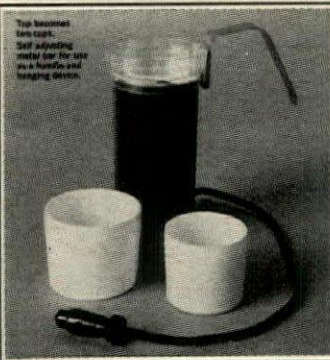

AUTO COFFEEMAKER

Actually brews four cups of real coffee; also heats soup, tea, etc. Plugs into cigarette lighter (12 volt systems). Signal light; thermostatically controlled. View gauge shows level of coffee; cleans easily. Highest quality materials. Metal bar for handle and hanging device. Guaranteed one year.

\$17.95 Ppd.

W.E. DODSON COMPANY

HG-11
P.O. Box 806, Cucamonga, Calif. 91701

May We Send You 18 Assorted PERSONALIZED Studio Cards?

(For Birthdays * Get Wells * Anniversaries, etc.)

No other cards like these available anywhere! These cards are more than personalized. Your first names (yours and your husband's) are actually part of the message. Makes your cards remembered. These sophisticated Slim-Jim cards, all in impeccable taste are colorfully printed on fine heavy stock. Money refunded if not delighted. The ideal gift for Xmas. Try our "Connoisseur's Assortment" of 18 cards (all different!) with matching envelopes. (10 birthdays, 4 Get-Wells, 2 Anniv's, 2 Congrat'ns) or make up your own assortment. Orders shipped within 48 hours. Send printing advice and \$5.95.

COLLEGE HALL CARDS, Dept. E
199 Hickory Drive Larchmont, N.Y. 10538

Ruth and Joe
had a great idea
for your
Birthday...



WORTH LOOKING INTO

Selling your particular product or service by mail.

Advertising your area's shops and services in a special section.

Interested? Write to us for complete information on how you can sell and promote profitably in House & Garden's Shopping Around Section. . . . America's largest shopping-by-mail-center.

HOUSE & GARDEN SHOPPING AROUND

420 Lexington Avenue, New York, N. Y. 10017

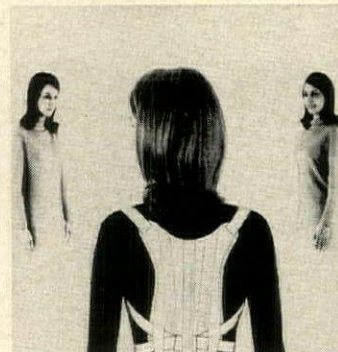

STOOP STOPPER

Sagging shoulders get a lovely lift with the Pi Peer shoulder brace, a lightweight device that puts posture on the straight and narrow. Three-ply ventilated material with softly-padded invisible arm bands. Men measure around chest; women below bust. \$6.95 plus 45c post. Piper Brace, Dept. HG-101SH, 811 Wyandotte, Kansas City, MO 64105.

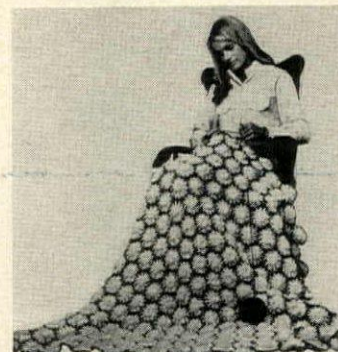

DAISIES ARE A-LOOMING

You make the daisies on a loom and in less than a week of long winter evenings. Complete kit has machine washable yarn in white, lemon yellow and avocado, carrying case, loom and instructions. Finished size 48" by 62". \$9.98 plus \$1 post. Colonial Studios, Dept. ADN-81, 20 Bank St., White Plains, NY 10630.



BIGGER THAN LIFE

Gobble up whole pages of print at four times the size with this super magnifier. Wafer-thin, for storage right in the book; page-big, for an end to lost places. Mock leather frames the 7" by 10" plastic. Unbreakable and dandy for phone book, dictionary or fine print. \$1.50 ppd. Walter Drake, HG47, Drake Bldg., Colorado Springs, CO 80901.

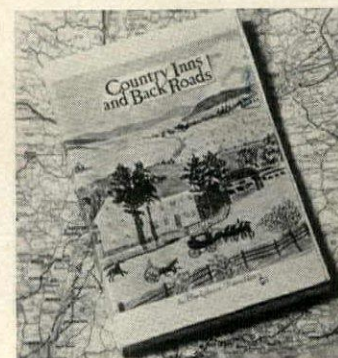

BYWAY DELIGHTS

For all planning to visit America, "Country Inns and Back Roads" is a treasure trove of happy discoveries. It visits 70 country inns from Maine's rock-bound coast to California's Pacific shores. The almost forgotten roads offer a glimpse of long ago. \$2.95 ppd. The Berkshire Traveller, HG10, Stockbridge, MA 01262.

SHOPPING AROUND

FILM OF FANTASY

Nylon and Spandex stretch fabric underline today's look of nature. Fashioned into a bra and the briefest of hip-hugging bikini briefs. White only in one size to fit 32 to 38. Wear them for sports, all knits like a second skin. \$5.98 plus 20c post. Anthony Enterprises, HG10, 585 Market St., San Francisco, CA 94105.



PRINCELY PLAQUE

Make a man's home his castle with the family coat-of-arms on display. Embossed copper on polished mahogany base, hand-painted motto. 8" by 5", \$18; 10" by 7", \$22; 13" by 10", \$33. On hand-painted parchment in black frame: 10" by 7", \$23.25; 14" by 10", \$26. Add \$1 post. "1776" House, G49, 260 Mass. Ave., Boston, MA 02115.



PET DOOR

You couldn't ask for a more convenient invention than this Flex-port door. Lets your pet go in and out at will via flexible plastic triangles. Eliminates annoying whining, destructive scratching. Keeps out rain, snow, wind, bugs. Eight models. Write for free catalogue. Turen, Inc., Dept. 610, Danvers, Mass. 01923.



HEARTY PALMS

If your taste runs to exotic flora, then a palm's definitely your kind of plant. Feathery leaves crown a slim stem which—with t.l.c.—grows and grows. Three to a pot, one pot \$3 plus 50c post.; two pots, \$5 plus 75c post.; three pots, \$7 plus \$1 post. Disguise your patio as a tropical retreat. Palm Nursery Co., Dept. H10, Box 383, Westport, CT 06880.



PERFECT PAIR

There is no nicer way to preserve baby's first shoes! Bronze plated in solid metal to last forever. Also portrait stands (shown), book-ends, TV lamps. Send for full details, money saving certificate, and handy mailing sack. A lasting gift for grandparents. \$3.99 pr., ppd. American Bronzing Co., Box 6504-K5, Bexley, OH 43209.

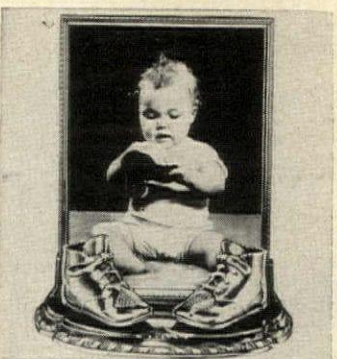

LEARN REUPHOLSTERY

Save money and be creative. Learn the skill of upholstery. Illustrated book gives steps from start to finish for all kinds of frames plus how to measure, cut and fit materials, tools needed. Even first-timers can learn step-by-step. \$1.45 plus 50c post. Lacson Upholstery Co., HG10, 2720 N. E. 7th Ave., Pompano Beach, FL 33064.

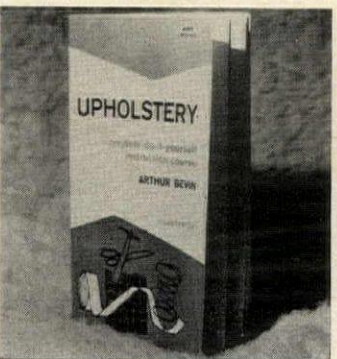

DOVE OF PEACE

BY BROWER ©



"An unusual gift of the times." Enjoy this beautiful sculptured symbol of peace for your very own. Perfect gift for any age. Hand cast in a wood finish. Height—15 inches. Limited special—only \$17.95, plus \$2.00 for postage and handling. Money back guarantee. Order from

MUSEUM TREASURES

24-30 Brooklyn-Queens Exp. West, Woodside, N. Y. 11377

PRE-COLUMBIAN ARTIFACTS



Large selection of authentic ceremonial vessels, burial pieces and figures excavated from tombs in Mexico over 1000 years old.

SEND \$1.00 FOR CATALOG NO. 10

HARTWELL KENNARD
1015-B NYSSA STREET
MCALLEN, TEXAS 78501

CREATIVE QUILTING

Our service is to custom quilt your fabric and make it into a finished bedspread in the style you select, using the measurements you send us. The "Composition" design pictured starts at \$35.00. Send \$1.00 for samples of designs and pictures of styles available to choose from. We'll also send you detailed information on how to measure for bedspread yardage.

CAROLINA STUDIOS

P. O. Box 191
Dept. HG
Southern Pines, N. C. 28387



FUN FASHIONED KNITS FOR TODAY'S MAN

For the look of today, these beautifully styled knits are sure to please the discriminating man. The sleeveless belted U-neck sweater is made of "WINTUK" Orlon® acrylic yarn. A perfect match is the ribbed turtle neck shirt of 50% polyester and 50% cotton. This attractive trim fitting set makes the ideal Xmas gift. Both are machine washable and are available in the following colors: Navy, Bone-white, Burgundy and Espresso Brown. Specify S, M, L, XL.



U-Neck Sweater \$12.00 plus 75c pp & hdg.
Turtle Neck \$12.00 plus 75c pp & hdg.
Combination of sweater and turtle neck
\$23.00 plus 75c pp & hdg.

HOWMAR SALES CO.
P.O. Box 591
Corona, N.Y. 11368

HOME DISPLAY CASES

PROTECT and BEAUTIFY

DOLLS • FIGURINES
GEMS • CLOCKS
MODELS
ANTIQUES
SILVER
ART OBJECTS
TROPHIES
COLLECTOR'S ITEMS
WEDDING FIGURES
KEEPSAKES • CHINA

PROTECT YOUR VALUABLES
from accidents and pets.

BEAUTIFUL CASES!

Sparkling acrylic-clearer and 15x stronger than glass. (Like jet airplane windows)

ENDS TIRESOME DUSTING
of delicate, frilly things.

ANY SIZE YOU WANT

Send measurements for FREE price quote. Custom-building at low factory-to-you prices.

ORDER NOW FROM:

CASECRAFT

Dept. 1A Box 155
Lemon Grove, Calif. 92045

Stock Sizes

W	L	H
5 x 5	7	\$ 9.50
5 x 5	11	12.50
6 x 6	9	12.50
6 x 6	14	16.50
6 x 12	6	16.50
7 x 7	11	16.50
7 x 7	16	22.50
7 x 15	7	21.50
8 x 8	14	23.50
8 x 8	20	30.50
8 x 18	8	29.50
9 x 20	9	34.50

(without black base-\$2.50 less)

MONEY-BACK GUARANTEE
(add \$1.50 post. Calif. residents add 5% sales tax)

Send check, cash, money order.
Or use:
BANKAMERICARD
MASTER CHARGE

"See-Thru" GOURMET COOK BOOK HOLDER

Keeps Your Cook Books Clean

No more prying apart food stuck pages of your favorite cook book. This newer, larger, more solidly constructed, miracle clear, heavy gauge lucite stand holds your cook book open to desired page at an upright angle that is "easy-to-read". Clear plastic shield prevents those treasured recipes from being splattered. Hands are free to do the cooking. Holds any size book. Washable. A must for every kitchen, great gift for the bride. 10" high x 11" wide. Only \$9.95 ppd.

Send check or M. O. Satisfaction Guaranteed.
N. Y. Res. Add 7% Sales Tax

EDITH HAAS, Dept. HG10, 130 West 42nd St., New York, N. Y. 10036

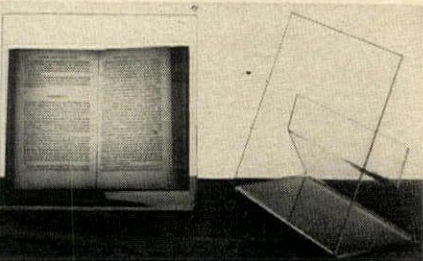

The GAUCHO LOOK
is made for you . . .

Natural homespun BO-LERO and TROUSERS are lavishly trimmed with Indian and Spanish braids. \$49.95 ppd.

Romantic GAUCHO BLOUSE of no-iron dacron is available in rust, black, turquoise, red, or dark green. \$21.95 ppd.

Please give measurements for bust, waist, hips, shoulder width, sleeve length, front bolero length and inseam and outseam (not including band) length for trousers.

Send for **FREE CATALOG** of other Desert House specialties.



Desert House
Dept. HG-2
P. O. Box 11114
Albuquerque,
New Mexico 87112



SANGRIA PITCHER • WINE GLASSES

This handsome curveaceous pitcher of modern design holds 80 oz. (10 cups). Height 10". Thistle Glasses are 11 oz. size, 7" tall, an original design from our own exclusive molds. Fine for serving Sangria or other table wines. Hand blown in U.S.A. Heat tempered, & dishwasher safe. Approved by wine Authorities everywhere.

SANGRIA PITCHER \$6.95 Ppd.
THISTLE GLASSES (set of 6) \$14.95 Ppd.

Many other traditional & distinctive Wine Glasses available. Write for Catalog. (Cal. Res. add 5% S. Tax).

WINE GLASSES
Box 732 (HG10), Sausalito, CA 94965

SHOPPING AROUND

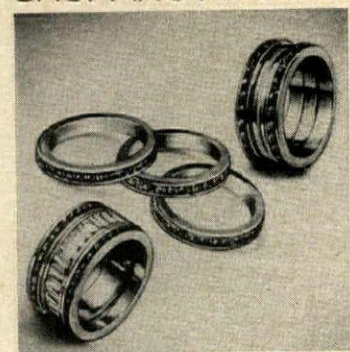

RINGING CHANGES
Sometimes guard rings deserve a fashion life of their own. How? Try a mix of make-believe topaz, aquamarine, emerald, diamonds, amethysts, sapphires, rubies set in sterling silver, gold plate. One, \$3.50, two for \$6, three for \$8.50. Real turquoise \$8.50; silver baguette, \$5.50. Ppd. Vicki Wayne, 610-HOG, So. Country Club Rd., Tucson, AZ 85716.



PLAINS INDIANS
Full color prints are available in a limited edition of 1,000 pairs signed by artist, Randy Steffen and numbered. The handsome prints are 17" by 28". The prints are brilliantly decorative hung in family room or study. \$50 a pair plus \$2 post. Other Steffen Indian prints available. Frame House Gallery, Inc., HG10, 110 E. Market St., Louisville, KY 40202.



RADIO NOTEBOOK
They'll never figure it! Sound from a notebook? Yet that's exactly what the Binder-With-A-Beat offers. It has a hidden radio and speaker so you have music wherever you go—on the way to school or for news broadcasts in the classroom. Easy-clean orange vinyl. \$12.95 plus \$1 post. House of Minnel, Dept. HG501B, Deerpath Rd., Batavia, IL 60510.

January

S	M	T	W	T	F	S
2	3	4	5	6	7	8
9	10	11	12	13	14	15
16	17	18	19	20	21	22
23	24	25	26	27	28	29

*Elegance
pour le bain*

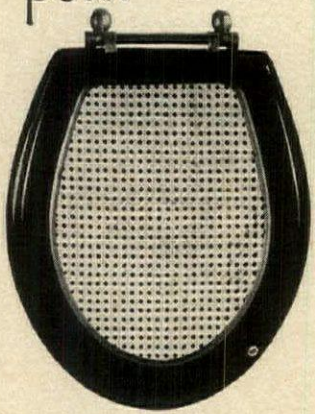

All wood toilet seat. Natural cane insert cannot sag. Patented color-matched hinge. Fits all standard fixtures. Easy to clean. Simple to install. Fully guaranteed. Colors: white, antique white, metallic gold, avocado, dark blue, sky blue, desert pink, black, lime, canary, silver, wood-grain, orange, red and purple. Shipped anywhere in U.S. \$12.95 parcel post included. Sorry, no COD. Send 25¢ for our brochure. The One-Nineteen Shop, 119 S. 19 St., Phila., Pa. 19103. Telephone: (215) LO 3-1402.

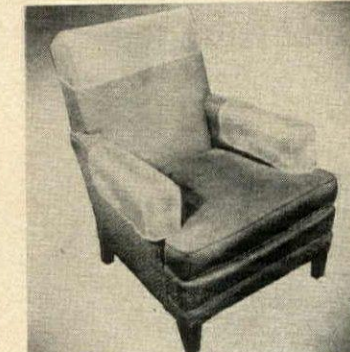

ARMCHAIR PROTECTION
See-through plastic covers for the back and arms of a favorite chair protect the upholstery and eliminate stains from hair and hands. The back cover is held by elastic; the arm covers fastened by expandable bone snaps. \$1 a set plus 15c post. Anthony Enterprises, HG10, 585 Market St., San Francisco, CA 94105.

THE WORLD'S LARGEST CALENDAR

12 individual sheets 35" x 45", hand screened bold black numbers on white paper. \$13.00 includes postage and handling anywhere in the U. S., California residents add 7% state sales tax. Allow three weeks for delivery.

MAXI-CALENDAR 1972
HOME BEAUTIFUL
1355 Market Street
San Francisco, California 94103

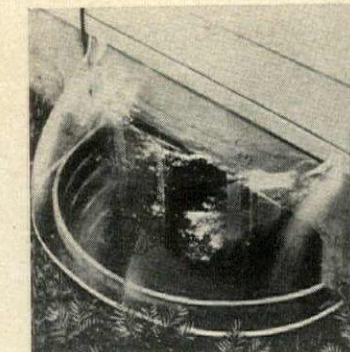

ACRYLIC PROTECTOR
Everyone who has labored digging out dried leaves, stray papers and such from the well around a cellar window, welcomes an acrylic bubble. Covers wells up to 40" l., 12" h., and 16" d. Lets in light. Keeps out rain, snow, mice. Metal stakes sink into earth. \$15.95 ea. Exp. coll. Dilworth Mfg., HG10, Box 285, West Chester, PA 19380.

GOOD LUCK MUSHROOM WALLBOXES



Charming European Good Luck Mushrooms in a nest of misty mountain flowers . . . framed in a stained wood wallbox completed with complementary ribbon. Everyone will love this colorful and permanent 3 dimensional decoration. Brightens any wall.

Use alone . . . or in groupings . . . excellent for gifts too!

\$4.95 each plus 50¢ postage and handling
CHOICE OF 5 COLORS:
• yellow • orange • green • red • natural •

Send check or money order to:
**ALPINE ARTS, P.O. BOX 9040
COLORADO SPRINGS, Colo. 80909**
Color _____

Name _____
Address _____
City _____ State _____ Zip _____

For **Bosom Beauty**



Try the one tested, trusted body creme that contains a full 60,000* units of **ESTROGENIC HORMONES**

If you believe, as so many beauty experts do, that your body is the true key to feminine allure—then the one name you should remember from now on is LA VIVE . . . because La Vive Body Creme has helped thousands for more than ten years! This superior formula features 20,000 units of natural estrons and estrogenic hormones per jar plus additional beneficial oils especially designed to moisturize and lubricate . . . yet will not alter structure. No wonder so many grateful women have expressed their thanks in enthusiastic letters of praise to our beauty advisors! Stop envying others! Instead, try the 60-day supply of La Vive Hormone Creme without risking a penny. It's guaranteed — you must be absolutely thrilled with results or simply return the jar for money back without questions! 60-day supply (mailed in plain wrapper) only \$1.98. *Special: Triple supply only \$5.00 postpaid.

FREE! Act now and receive with your order our exclusive beauty booklet that reveals the coveted glamour secrets of facial and body allure known to the world's loveliest women! This valuable guide is yours free — send today! **AMERICAN IMAGE CORP., Dept. L-269-S**
276 Park Avenue So., New York, N.Y. 10010



LIFT OFF
For the female who has unwanted hair on her face, arms and legs, we propose Perma Tweez. Easy as rolling off a log, battery operated device removes the stuff painlessly, professionally. To boot, a bottle of splendid moisturizing lotion comes with: free. \$16.95 ppd. General Medical Co., HGE-28, 5701 W. Adams Blvd., Los Angeles, CA 90016.

SHOPPING AROUND

WALK WAYS

Styling and comfort go together in foot fashion this fall. Soft leather two-eye-let tie has a moccasin air. Black, taupe, white, platinum or red on a ripple sole. Called Walkathon, it comes 5A's and 4A's, 6 to 12, 3A's, 2A's, A and B, 9½ to 12. \$20 plus \$1 post. Free catalogue. Mooney & Gilbert, Inc., HG10, 31 W. 57 St., NY 10019.



AUTOMATIC ADDITION

Automatic machine keeps budget within bounds on marketing trips. Click buttons add up to \$20 automatically. Handy to have along for your weekly grocery shopping! Children can keep track of their allowances. \$1 plus 15c postage. Write to Anthony Enterprises, HG10, 585 Market St., San Francisco, CA 94105.

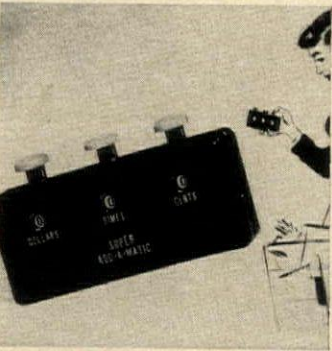

PREHISTORIC WEIGHTS

Fabulous crystalline stones, called geodes, are splendid paperweights, lovely display pieces. Mixed blue, gray and brown swirled crystals with explanatory material. One 4" half or two 3" mating halves, \$5.95 plus 95c post. Smaller whole geodes, \$2 each; four, \$7.20. Ppd. Postmatic Co., HG1071, Lafayette Hill, PA 19444.



DREAM GREENHOUSE

Aluminum pre-cut and pre-fit glass greenhouse is one of more than 100 offered in an exciting and colorful catalogue. It answered all our questions about home greenhouses and you'll find it informative. It's priced at \$1 and shows ready-to-assemble models. J. A. Nearing Co., Inc., Dept. Y10, Box 346, 10788 Tucker St., Beltsville, MD 20705.

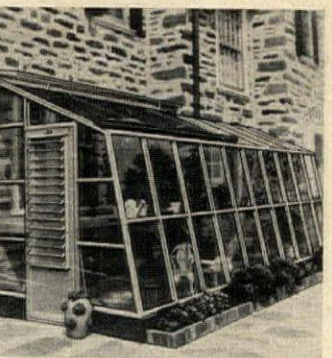

QUICK TRIM

Handy hair-trimmer does the job professionally in minutes. Made in Sweden, it's a fine quality tool, has an adjustment for regular trim, medium trim or scalp-close. Trims as it combs. Mom can do the job or Dad and young long-hairs operate it easily. \$2.98 plus 15c post. Anthony Enterprises, HG10, 585 Market St., San Francisco, CA 94105.



OVAL ART

Beguiling bisque plaques to group in a little girl's room, naturally, but wouldn't they be charming in a newly decorated bath? Greens and gold; with velvet loops and brass hanging rings. 3½" by 4½", \$3.95 each; smaller sizes available. Add 45c postage. Catalogue, 25c. L. T. Barth Studios, HG10, 3220 Northaven Ct., Dallas, TX 75229.



IRISH ELEGANCE



Here is a gift for the man who chooses his handkerchiefs as carefully as he does his suit. Exquisite, hand-rolled, Irish linen handkerchiefs 19" X 19" with full name cut into linen. \$4.75 each ppd.

Box of three handkerchiefs with the same name. \$13.50 ppd.

With two or three initials, \$3.95 each or box of 3 for \$11.25 ppd.

Add \$1.25 for Air Mail Special Delivery

If desired, name or initials can be ordered in any color.

Send 25c for brochure

VILLARI HANDKERCHIEF COMPANY

30 West 54th Street, Room 516
Dept. HG10-1, New York, NY 10019

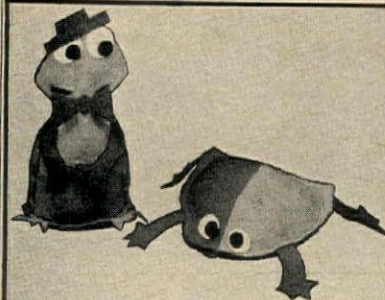

IDEAL GIFT to brighten up the young at heart. **CONVERSATION FROGLET** (standing up) seven inches and **FROGLET JUNIOR** five inches; Felt covered - Milo filled.

Conversation Froglet comes in Sunshine-Orange with Yellow trim, Lavender with Purple trim, Bright Yellow with Chartreuse. All with contrasting colors on hat and bow tie.

Froglet Junior comes in Orange with Yellow trim, Lavender with Pink trim, and Chartreuse with Peacock trim.

@ \$2.25 ppd., any 3 for \$5.50 ppd. (Check or money order - No C.O.D.) any style, any color. Calif. residents add sales tax. **ORDER NOW FROM TOWNTEX · 447 Minna Street San Francisco, California 94103**

Your choice of imitation

Opal, Amethyst or Jade stones in a distinctive openwork, filagree ring setting. Fully-adjustable, 18K gold plated, Style #301, only \$2.



Genuine Tiger-eye stones, dramatically integrated into a fully-adjustable, 18K gold plated free-form ring setting. Style #304, only \$3.

House of **Camelot**

38 Carrol Court Greenlawn, N.Y. 11740

Send for new free full color catalogue

skinwear

Puccini Brief in geometric nylon-tricot prints with an Italian flair of design, bikini styling, all washable. In assorted multicolor prints. S-M-L-XL. An assortment of 3 for \$9.95

SnakeSkin Brief, same cut as Puccini brief, lightweight tricot, wash & wear, compact for travel, available in Cobra (tan/dark brown) or Python (grey/blk). S-M-L-XL. \$3.50 (3 for \$9.95)

Pouch-Front Boxer under-shorts, lo-rise pull-on styling, nylon-tricot (designed for wearing Ah Men's foam rubber athletic cup, \$2.00). Blk, Wht. or nude. S M L XL \$3.50

NEW SEND 25c FOR OUR NEW CATALOG.



No C. O. D.'s
Add 50c postage



The New Shop for Men
AH MEN
Dept. HG 110
8933 Santa Monica Blvd.
Hollywood, Calif. 90069



THE PEWTER LOOK

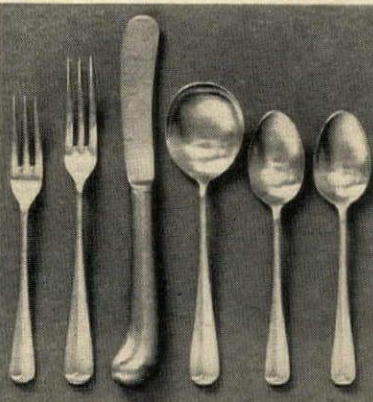

Our stainless steel flatware authentically reproduced from an antique English design. Classic pistol handle knives, 3 tined forks, and a mellow pewter look. Dishwasher safe. Service for eight includes: 8 dinner forks, 8 dinner knives, 8 salad forks, 8 soup spoons, 16 teaspoons and 2 serving pieces.

Service for 8.....\$29.98
Service for 12.....\$44.98

Prices include postage & handling

Wales, Dept. HG1071
Hartsdale, N.Y. 10530

Grandma Howard's Little Red Chair Old Fashioned Bent Wood Bow Back

She has had it for nigh on to 60 years. Right now it has a place of honor near our fireplace and when our grandchildren come over they think it is great. So many of our friends have said "I wish we could buy one like it", that I decided to duplicate it. Made by a master woodcraftsman using only solid northern hardwoods exactly as in the original. Genuine bent wood bow back of finest ash. Not a toy but a rugged piece of furniture, solid strong and sturdy. Made for the rough handling and daily use of growing youngsters.

About 27" high, 13½" seat to floor, 12" x 12" seat size. **NOT SOLD IN STORES.** Be remembered by your grandchild for this wonderful gift that could become an heirloom in his or her own family.

Chair assembled, enameled in fire engine red.....\$33.50

Shipping charges collect. Minn. residents add 3% tax. Send check or money order (no C.O.D.'s) to

GRANDPA HOWARD'S WORKSHOP
RT. 3, PLEASANT VALLEY, WINONA, MINN., 55987.



FREE! IN FULL COLOR



NEW WOOD FOLDING DOOR IDEAS

Before you build, buy or remodel, send for this helpful Brochure. Shows how to stretch space for family living . . . divide it for precious privacy . . . hide work, storage and utility areas decoratively. Do it with the natural beauty of genuine wood. Mail coupon today.



THIS COUPON ANSWERED WITHIN 24 HOURS
ROLSCREEN COMPANY, Dept. XC-52
 PELLA, IOWA 50219
 Please send me FREE full-color
 PELLA Folding Doors Idea Brochure.

NAME _____
 ADDRESS _____
 CITY & STATE _____ ZIP _____

PELLA MAKES QUALITY WOOD WINDOWS,
 WOOD FOLDING DOORS & PARTITIONS AND
 WOOD SLIDING GLASS DOORS

HYPONEX
 Soluble PLANT FOOD Complete
 GROWS BETTER PLANTS INDOORS OR OUTDOORS
 In Poorest Soil -- Even in Sand or Water
 Preferred by millions for 30 years. Simply dissolve
 in water and feed all plants through roots or foliage.
 Clean, odorless. If dealer can't supply, send \$1.29
 for 10 oz. Makes 60 gals. 75 items catalog Free.
 HYDROPONIC CHEM. CO., Copley, Ohio 44021, U.S.A.

Indoor Fountains Perfect air conditioning
 Automatically changing color display.
 Porcelain fountain statue! Changeable
 nozzles with 26, 36, 48 or 50 outlet holes.
 Models from \$17.25. Write for free color catalogue.
 Garvens OHG, 3251 Aerzen, Dept. 16 West Germany

LIQUID WRENCH
 LOOSENS RUSTED BOLTS
 NUTS & PARTS IN SECONDS

GROUND COVER
 ENGLISH IVY
 1-year, heavy, rooted cuttings, 6-in. to 10-in. Hardy, evergreen, fast-spreading.
 PACHYSANDRA
 A fine evergreen ground cover in sun or shade. 1-yr., heavy cuttings, 3-in. to 4-in.
 MYRTLE (Vinca Minor)
 Extra large leaf and large light purple flowers. Bare rooted clumps with an average of 6 to 12 runners per clump. Space all items on 6"-8" squares. All items: Postpaid planting time. Pa. destinations add 6% tax. No. C.O.D.'s. FREE COLOR CATALOG.

100 of any one ONLY **\$14.95**
 \$65.00 per 500

MUSSER BOX 9K INDIANA PA. 15701

Gardener's notes

BY JAMES FANNING

A TOTAL ENVIRONMENT FOR PLANTS is provided by a miniature greenhouse, right, called the

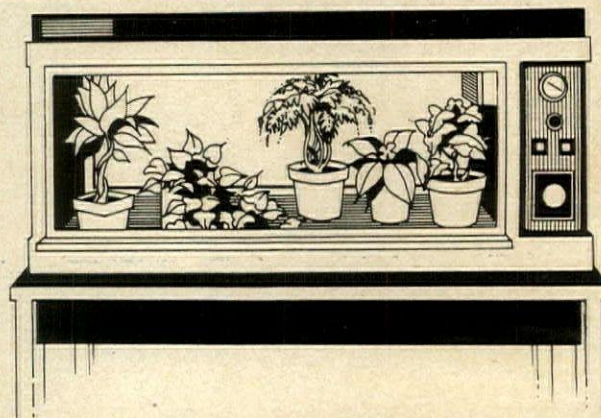

Phytarium. Light of the proper intensity for plant growth is turned on and off by an automatic timer, carbon dioxide

in carefully metered amounts is added to the air, and water containing fertilizer is doled out to the plants through wicks from a reservoir. All of this in a neat, glass-sided cabinet that need not be opened for weeks on end. The Phytarium comes in two sizes (15 1/2-by-45 5/8-by-21 1/2 inches high and 15 1/2-by-45 5/8-by-27 5/8 inches high), also as a do-it-yourself kit consisting of the mechanical equipment to be attached to your own cabinet. The kit is \$200, the complete Phytarium \$860 and \$1060, f.o.b. from Environment One Corporation, 2773 Balltown Road, Schenectady, N.Y., 12309.

THE ANCIENT AND HONORABLE PARSNIP has fallen into disfavor.

This may be because gardeners of recent years have forgotten it is one vegetable that should *not* be used when it is young and, presumably, tender. Young parsnips tend to be bitter and somewhat stringy. The old practice, and still the wise one, was to leave them where they grew, let them freeze in the snowbound soil, and wait to use them until early the following spring. Hacked out of the thawing ground, scrubbed, split lengthwise, and baked with butter and a sprinkle of brown sugar, parsnips are delectable.

A PATIO UNDER YOUR FAVORITE TREE may be one of the dooryard improvements you're planning for this fall. If so, don't forget the tree itself. A pavement impervious to air and water can smother roots, cause irreparable damage to the tree itself. So make sure to cover the roots with coarse gravel before paving over them and leave openings in the pavement for air and water to get through. Another point to keep in mind is possible damage to tree branches from grills and barbecues. Rising heat from a cooking fire can scorch limbs several feet up, so keep your fireplace outside the branch spread of any tree you value.

A REEL MOWER CANNOT BE BEAT FOR THE JOB OF GIVING A LAWN A TRULY FINE FINISH. GOLF COURSE MANAGERS AND OTHER PROFESSIONALS INSIST ON THIS TYPE OF MACHINE. A GOOD MANY PEOPLE WITH ORDINARY HOUSE LOTS PREFER REEL MOWERS, TOO, AND YARD-MAN IS NOW PRODUCING A MOWER, *RIGHT*, ESPECIALLY FOR THEM. CALLED, UNDERSTANDABLY ENOUGH, "THE PROFESSIONAL," THE MOWER IS SELF-PROPELLED AND HAS SOMETHING THAT REEL MOWERS HAVE LONG NEEDED: A REEL GUARD FOR SAFETY. IT IS MADE BY THE SAME COMPANY AS THE SNOWBIRD SNOWTHROWER, *BELOW*, AND IS AVAILABLE FROM YARD-MAN DEALERS THROUGHOUT THE COUNTRY.

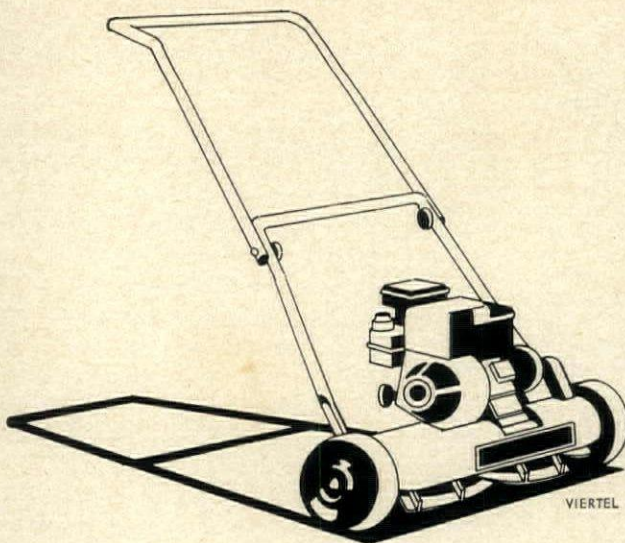

THREE RIDING TRACTORS are the first machines introduced by New Holland as part of its new line of equipment for small homeowners. (Generations of farmers have relied on farm machinery by New Holland, now a division of Sperry-Rand Corporation.) Rated respectively at 8, 10, and 12 horsepower, the tractors are easy to operate because of the compact design, which includes a tilting steering wheel to let you in and out of the driver's seat without gymnastics. Key starting promotes safety, and power takeoffs at front, rear, and center provide for a great variety of attachments such as front-end snowblower, center-mount lawnmower, and rear-end cultivator. You will find the New Holland lawn and garden tractors on sale at franchised dealers this fall. Prices had not been announced by press date.

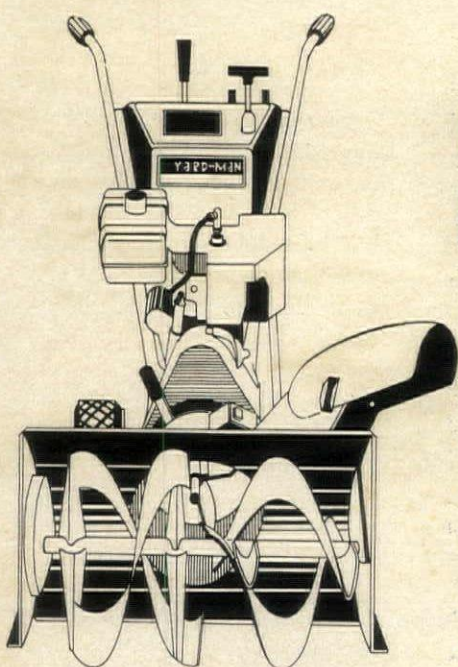

SNOWTHROWERS are rapidly becoming everybody's favorite way of clearing up the white stuff. They chew through drifts that would stall most plows and toss the removed snow well away from the space that is being cleared. The Yard-Man Snowbird, left, is available in two models, a 24- and 26-incher, with 5- and 7-horsepower motors, respectively. Both of them have five forward speeds in addition to reverse, and the traction wheels may be power driven or set to free-wheel for hand pushing. Retail prices are about \$350 for the 24-inch model, \$400 for the 26-inch. Made by Yard-Man, 1410 West Ganson St., Jackson, Mich., 49202, they are sold through franchised dealers throughout the country.

IT SERVES YOU RIGHT!

GENSE

The today answer to sensibly priced, versatile serving appointments plus no-care maintenance is found in this great Swedish collection of 18/8 stainless. Send 25¢ for 36-page catalogue. GENSE Northvale, New Jersey 07647.



Make your two-story home seem like a rancher.



Install an *Inclinette*

Why climb your stairs when an Inclinette can take you up and down with just a push of the button?

Inclinette is the safe and easy way for the handicapped or elderly . . . is more convenient for the whole family.

Write for new, free booklet . . .

with information on Inclinette - 2 passenger INCLINATOR - "Elevette" the modern home elevator. Equipment is tax deductible when recommended by doctor.



INCLINATOR COMPANY OF AMERICA
2300 Paxton St., Harrisburg, Pa. 17105



At last, a shower just for you. You can hold it in your hand; adjust its spray. Or use it as a wall shower at any height you prefer to shower without wetting your hair. Bathe with complete freedom as you have never bathed before. Add an Alsons Personal Shower to your bath. 22 models to select from including brush and bidet attachments. Available wherever finer home products and plumbing goods are sold.

Lady Alsons
PERSONAL SHOWER
America's freshest new bathroom idea

alsons
 PRODUCTS CORPORATION
 Somerset, Michigan • Covina, California

AT SUSANNA RATTAZZI'S *continued from page 117*

see, and sits and has tea or coffee or a drink, and the friend I wanted to talk to and be alone with gets nervous and leaves and rings up to say, "Do you think, Suni, it will ever be possible to sit with you and *not* have three people join us?" and I feel guilty and say "Of course, you are right, I am sorry, next time I promise it won't be that way. I will be alone." And of course I am not. I go out one evening and come home and there is my daughter half naked in the hall. "Mama," she cries, "it never stopped raining in Antigua, so we came to stay with you." Her husband walks out of the shower and we talk all night.

Or I walk in one afternoon with a very serious lawyer whom we must discuss very boring business with and the hall is covered in suitcases and clothes thrown all over the place. My son appears in a cherry-colored towel (yes, my children tend to be undressed). "What are you doing here?" "My girl friend in Argentina refuses to go to bed with me so I couldn't stand it any longer and I decided to come here." "Why won't she go to bed with you?" "Because she is Argentine and she is a virgin." "Oh, I see, are you in love with her?" "You know I am never in love. I like her. I take her out dancing. I like talking to her. But I can't stop thinking about going to bed with her and it makes me mad. Come with me, I want to go and buy her a present." So we go out and the serious lawyer thinks I am not serious at all. And the next day my other son arrives. "I forgot to get a visa," he says "that's why I am late." He wants to go to college in the States and spends whole days filling in thousands of sheets of applications. "Where did you go to school?" he yells from some part of the carpet on which he is lying. "How much income do you have? How much do you expect to spend for my college training? How many years did 'Papa' study for? Do you think I intend to get married during the next four years?" The telephone rings incessantly; we all answer from different rooms; we all start talking in Italian and finally who was calling gives up and we go on talking from one room to another on the telephone until it rings

again and we all put the receiver down and nobody answers.

And then the suitcases are there again in the hall, and the clothes plus blue jeans and leather jackets are piled up in heaps. "What's happened now?" "I am going back to Argentina; I don't care if she doesn't go to bed with me. I want to see her." "I thought you weren't in love with her?" "But what am I going to do with the presents I bought her if I don't go back?" Panties and brasieres and T-shirts and necklaces are all over the place. "I see what you mean," I say, and kiss his long fair hair, which the New York climate has standing straight up like a sugar swirl.

And the other son goes back to school. And I am alone again. And the telephone never rings and the door is shut and all my friends have gone away for the weekend and I listen to music with an empty hunger.

One day I wake up and feel depressed. My cheek under my left eye is twitching; suddenly it tightens like an eyelid in sunshine and there is nothing I can do about it except hope it will stop, suddenly, as it began. I ask Francisca to put on some music downstairs and she is sure to choose that song that makes me want to cry, that concerto that stirs inside me the longing for something that used to be happiness. The sky is yellowish, the color of saffron rice in a Swiss "buffet de la gare," the color of dust on a road in Teheran, the color of dead jellyfish lying on a beach. Why was one logical in life? Why did one try to be fair to others, to oneself? Why did one think that anything really mattered? Why did one hope that somewhere, something would change? I stare, I cannot write, I cannot read. I cannot put my coat on and go out.

Or the sun is out. The sky all sky-colored with just a fringe of very airy, very powdery white clouds. But still I am depressed. I go for a walk arm in arm with Mathias and say "Mathias, I am depressed. Don't be silly; if I knew *why* I am depressed it would be different. I wouldn't be depressed anymore." And the sun is so sparkling on the show windows and the flowers inside and Mathias buys me one artichoke that I bring home and eat,



Andersen Perma-Shield.
The low-upkeep window.

**Building or remodeling?
 This free book will help you!**

Get this 12-page booklet about a remarkable new vinyl and wood window that doesn't need painting or storm windows, resists denting, can't rust or corrode.

If you're planning to buy, build or remodel, send for free full-color booklet.

Please send me your free booklet, "Andersen Perma-Shield® The low-upkeep window."
 Mail to: Andersen Corporation, Bayport, Minnesota 55003.
 I plan to build. I plan to remodel a _____
 Name _____
 Address _____
 City _____ State _____ Zip _____
 HG-101

Andersen Windows™ 
 Window beauty is Andersen. Andersen Corp., Bayport, Minnesota 55003

alone, listening to the *Magnificat* of Brahms, which Francisca has, no doubt, chosen to cheer me up.

Francisca has a mother who is my age, so she stands at the bottom of my bed or at the side of the table and talks about life with a very sound philosophy learned in Tucuman; poverty and heat and sugar plantations. Her heart is so simple and good, her way of looking at things so primitive and so convincing that finally I smile and say "Sure, Francisca, you are right. Asi es. That is the way the world should be."

Sometimes I wake up when the sun is so bright it shines its way through all the curtains in little arrows of light being shot against the ceiling and the flowers and the patterned flowers of the wall. New York is shining, the wind whistling and moaning, rushing in through the open window, trying to fill my room with blue. I look across the roofs, the terraces, the people in the houses,

on the streets; across the forever of life. I induce Francisca into putting on a beautiful record full of romantic Italian songs; I drink my tea, I dream, I write inside my head what I will write at my table in the next half day. I look out of the window at a row of pink clouds visiting Manhattan; I fall in love with the sky; I fall in love with a man I have never met; I fall in love with a man I know too well. The world is dancing like the flames in the fireplace, like the light beyond the windows, like the fire in my heart.

The telephone rings, it is a lady, "You wanted a penthouse last year, would you like to buy it now?" "No, thank you, no!" Not another penthouse.

This is where I would like to die one afternoon, looking at the sky just before the sun begins to set, listening to a violin concerto, expecting a telephone call, not knowing how I am going to spend the evening.

BUILDING FACTS *continued from page 149*

Roof: Barrett built-up roofing system—layers of bituminous-coated building paper by Celotex Corp. topped with gravel.

Insulation: In walls, 3½-inch-thick glass fiber batts; on roof, 2-inch-thick rigid insulating board by Owens-Corning Fiberglas Corp.

Windows: Fixed glass panels; "Arcadia" anodized aluminum frame sliding glass windows by Northrop Architectural Systems with insulating glass.

Skylight: "Wasco" by American Cyanamid Co.

Doors: 1¾-inch-thick, solid core by U. S. Plywood-Champion Papers, Inc.

Garage doors: "Ro-Way" doors by Rowe Mfg. Co.

INTERIOR OF HOUSE

Walls and ceilings: Gypsum wall-board "dry wall" by U.S. Gypsum. **Interior finish:** Walls painted "seed pearl" white by Pratt & Lambert, Inc. Ceilings (2-inch Douglas fir tongue and groove decking, supported by exposed 3-by-12-inch fir rafters) all in natural stain by Samuel Cabot, Inc.

Floors: In entrance gallery, kitchen, and bathrooms, slate by Domestic Marble Corp.; carpet in all other rooms.

Lighting fixtures: Cylindrical ceiling downlights by Lightolier, Inc. with "Luxtrol" controls by Superior Electric Co.

Fireplace: Stucco on concrete block. Damper by Donley Brothers Co.

Hardware: Stainless steel from Elmer T. Hebert Corp.

Kitchen cabinets: St. Charles Mfg. Co.

Cabinet countertops: Formica by American Cyanamid Co. and stainless steel.

Plumbing fixtures: In kitchen, double stainless sink by Elkay Mfg. Co. In bathrooms, fixtures by American-Standard.

MECHANICAL EQUIPMENT AND APPLIANCES

Appliances: Ovens and range by Thermador Div. of Norris Industries; refrigerator and freezer by Revco, Inc.; "KitchenAid" dishwasher by The Hobart Mfg. Co.; "Trade Wind" by Norris Industries. Laundry washer and dryer by General Electric Co.

Heating-cooling system: Heating and cooling boiler by A. O. Smith Corp.; thermostatic controls by Honeywell.

Hot water heater: 80-gallon tank by A. O. Smith Corp.

How to make beautiful happen in your windows.

We have a book for you—full of beautiful (and helpful) ideas on what to do with windows. Compiled by top decorators, it tells all: about measuring, lighting, blinds, valances, drapes, colorful shades—and our spectacular new 1-inch Riviera blinds. It's all there. Send for your copy today.

Levolor-Lorentzen Inc.
720 Monroe St., Hoboken, N.J. 07030
Please send me a copy of your idea book, "Window Magic". I enclose 25¢ for handling and mailing.

HG-10

Name _____
Address _____
City _____
State _____ Zip _____

FREE FROM LEVOLOR

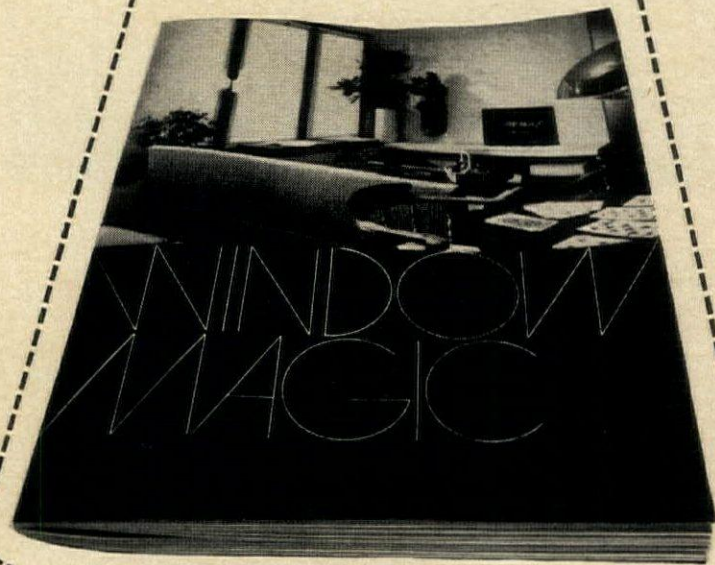

WOOD FINISHING MADE EASY



Home in Beach Haven, N.J.; Architect: Savery, Scheetz & Gilmore, Philadelphia, Pa.; Cabot's Stain Wax on paneling.

Cabot's STAIN WAX

Stains, Waxes, Seals in one operation

Time was when wood finishing was a long, arduous task. Today, Cabot's Stain Wax does the job in a single application. This unique "three-in-one" finish, suitable for all wood paneling, brings out the best in wood, enhancing the grain and producing a soft, satin finish in your choice of twelve colors plus black, white, and natural. When a flat finish is desired, use Cabot's Interior Stains.



Samuel Cabot Inc.

One Union Street, Dept. 1016, Boston, Mass. 02108

- Please send color card and information on Cabot's Stain Wax
- Enclosed 25c for Cabot's handbook on Wood Stains



Warm and classic and unusual. Tables and cabinets from the Monaco Group. Displaying the most beautiful combination of woods and veneers you've ever seen. Richly patterned grafted walnut for tops. Sliced walnut borders. Figured butt walnut for doors. And rich solid pecan. All finished to a glowing lustre. Look for the room setting shown here at your local Gordon's dealer during Debut '72 beginning in September. For a portfolio of the complete line of Gordon's tables and cabinets, send one dollar

DEBUT
'72 T.M.

GORDON'S INC.
Dept. HG-10, JOHNSON CITY, TENNESSEE 37601

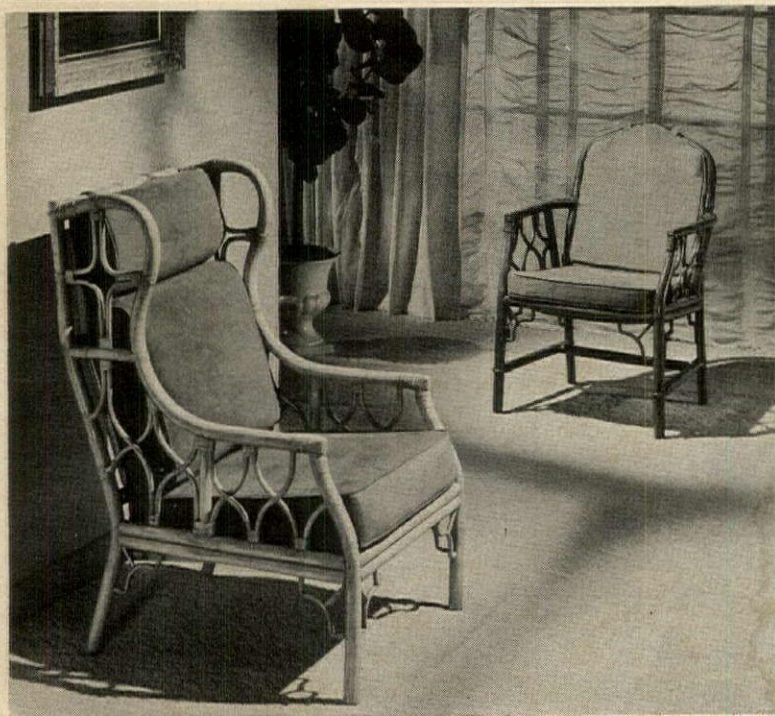

DESIGNED BY JOHN B. WISNER, F.A.I.D.

Chippendale...for Casual Elegance

Chippendale Rattan has all the welcome warmth of spring sunshine. As accent pieces, it adds that special touch of elegance so desirable in today's sophisticated interiors.

Write for descriptive literature, and name of nearest dealer.



"The Most Famous Name in Rattan Furniture"

4900 CHARLEMAR DRIVE, CINCINNATI, OHIO 45227

BEST IN BOOKLETS

Because House & Garden wishes to fill your booklet requests promptly, arrangements have been made for you to order directly from us. Fill in the coupon below, circling the number of each booklet desired. If remittance is required other than the 25c charge for postage and handling that must accompany each coupon, it will be indicated next to the booklet number. Enclose remittance in the form of coin, check, or money order only. Please do not send stamps. House & Garden will do all it can to see your requests are filled as rapidly as possible.

EATING AND ENTERTAINING

1. GEL POWER—Knox Gelatine has four pamphlets that can help you save money on meals, lose weight, and create festive, delicious party dishes—like "Peachy Parfait," or "Beef à la Mode"!

2. AN ITALIAN PROVINCIAL PIANO? Currier pianos combine superior tonal quality with richly grained cabinetry, in popular furniture styles—a twelve-year guarantee, too. Pamphlet shows the complete line, and explains the quality features. International Musical Instruments.

3. LIMOGES! Since the eighteenth century, Royale Limoges has been producing porcelain of exceptional translucency and whiteness. Colorful brochure shows twenty-five patterns—each with a freshness and vitality that are timeless. 25c.

DECORATING

4. TIME OUT. Ridgeway Clocks traces the history of timepieces from the Egyptian water clock, through the role of clocks in history, literature and legend, right up to the modern beauties. Colorful book shows how Ridgeway's clocks combine the best of old craftsmanship with new precision.

5. WHITE IS GRACEFUL—French Provincial furniture in White of Mebane's "Lorraine IV" collection. Thirty-two-page, fully illustrated catalogue offers groupings in dining, occasional, and bedroom furniture. 50c.

6. CREATE YOUR OWN ANTIQUES—with painted furniture and a handy booklet from Decor Master. The first section gives tips on choosing colors, painting, sealing, and applying

the antiquing solution. Second section describes toile designing with a choice of stencils. \$1.50.

7. IMAGINATION PLUS bedspreads and window treatments by Norman's of Salisbury can make a bedroom look as special as the ones shown in Norman's booklet of decorating ideas.

8. MIRROR, MIRROR on the wall—Bassett Mirror Co. has solutions for the "problem areas" of the home in a thirty-page, four-color booklet. Pictured are shapes and sizes for every décor. 25c.

9. CHANDELIERS FIT FOR A KING! In brilliant-cut crystal, burnished pewter and brass. Sixty-eight-page catalogue shows fixtures in styles to enhance every room. Or, create your own design with specifications from the booklet! King's Chandelier Co. 35c.

10. OLD SALT? Or just a collector of nautical touches—Preston's "Of Ships & Sea" catalogue is filled with authentic reproductions of marine prints, pictures, ship models, carved figureheads, brassware, giftware—all with minute attention to detail. 126-page catalogue. 25c.

11. RYA! rugs are so colorful and unique—it's like having an original work of art for your floor or wall—they're completely hand-knotted. Four-color catalogue shows the lushness and rich colors of each rug. Skon Rug Craft. \$2—refundable on \$25 purchase.

BUILDING AND REMODELING

12. FOIL A MOTH TODAY! Line your closets with Supercedar! Specially grooved boards make installation simple. Two pamphlets explain the advantages, and offer three cedar closet plans. Geo. C. Brown.

13. "VINYL IS FINAL." Brochure by the Mastic Corp. gives inside story on Contour T-Lok solid vinyl siding. Learn about the scientific design of vinyl and insulation possibilities it offers.

14. **DECORATOR FLOORS**—of solid oak, walnut, teak, cherry—in herringbone, parquet, domino, basket weave and colonial plank designs. Four-color booklets show how the woods have been rubbed to a mellow glow that complements any room. Easy to install, too. Harris Manufacturing Co.

POTPOURRI

15. **GOURMET GOODIES** from the originators of the "Fruit-of-the-Month" Club. Luscious fruit, food, and gift items are pictured in a colorful, mouth-watering, thirty-page booklet!

16. **IT'S A DOG'S LIFE.** Practical tips on all phases of caring for a puppy or adult dog. Included are proper feeding, training, exercise, grooming, and breeding requirements. Twenty-three-page book also dispels the "old wives' tales" about spaying. Mitchum-Thayer, Inc.

17. **QUICK AS A WINK**—learn the professional, simple way to apply false eyelashes with Duo Waterproof Surgical Eyelash adhe-

sive. Booklet has step-by-step illustrations on application and care, plus "tricks" with false lashes.

18. **BECOME AN ARGONAUT!** With Argosheen Carpet Cleaner. The Argo method dissolves the heaviest soil so it can be mopped away. Booklet includes tips on how to select and test a carpet before purchase for easy cleanability. 30c.

19. **HOW TO CARE FOR SILVER** is the theme of a booklet from W. J. Hagerty & Sons, Ltd., which includes tips on washing off silver tarnish, cleaning jewelry, and caring for flatware.

CHRISTMAS

20. **FRUITCAKES!** Your group or club can raise funds easily this holiday season with Benson's Old Home Fruit Cakes. Free sample slices make selling easy. Booklet gives details of high profit margin, plus bonus plan and Benson's special Hotline fund-raising staff to offer advice.

21. **CHRISTMAS TREE DECORATIONS** (over 300) to delight collectors young and old. Flat and three dimensional wooden creations handcrafted by Emgee in a style similar to that of the craftsmen of old Europe. \$1.

ORDER COUPON FOR BOOKLETS

October, 1971

Circle the number of each booklet you want, and enclose check, money order, or currency in amount indicated for those requiring payment. Add 25c for postage and handling. No stamps. Allow up to four weeks for delivery.

MAIL TO: HOUSE & GARDEN, Dept. #10
Box 3579, Grand Central Station
New York, N. Y., 10017

1	2	3 ^{25¢}	4	5 ^{50¢}	6 ^{\$1.50}	7
8 ^{25¢}	9 ^{35¢}	10 ^{25¢}	11 ^{\$2}	12	13	14
15	16	17	18 ^{30¢}	19	20	21 ^{\$1}

I enclose:

\$_____ .25 for postage and handling of my request for booklets

\$_____ for booklets circled requiring payment

\$_____ is my total remittance

Offer expires 12/15/71

Name MR. _____
MRS.
MISS (PLEASE PRINT)

Address _____

City _____ State _____ Zip # _____



white on white

What a way to dramatize a dining room! A plush white setting furnished with pieces from White's Lorraine IV Collection. A choice of 14 different finish combinations, including the most stunning color finishes you've ever seen. For a complete showing of the Lorraine IV Collection, send fifty cents to

White of Mebane, Dept. HG-10, Mebane, North Carolina 27302. And start coloring up your decorating with White.



Only Good Things Last!



BENNINGTON SOLID PINE

BY VERMONT OF WINOOSKI

Boldly beautiful dresser with abundant storage space. Masterfully distressed and antiqued, it has softened worn edges and glows with deep golden warmth. From the famed Bennington Solid Pine Collection of Early American bedroom, dining room, living room, functional and occasional furniture. See it at fine stores everywhere.

Send 25c for Debut '72 Color Brochure, Dept. A11, Vermont Furniture Co., Winooski, Vt.



Few things express individuality and taste so well as sensitively designed and appreciatively crafted traditional furniture—such as the Baker European and English collections. Each piece has the authenticity, excellence and enduring appeal of a unique collector's item. For a preview, send \$5.00 for the entirely new Baker Book.

Baker Furniture Co.

CABINET MAKERS

810 MILLING ROAD, HOLLAND, MICHIGAN 49423

NEW YORK • CHICAGO • LOS ANGELES • PHILADELPHIA • CLEVELAND
SAN FRANCISCO • ST. LOUIS • DALLAS • ATLANTA • GRAND RAPIDS

Division of The Magnavox Company



• FOR THE FINEST CARE OF YOUR FINEST FURNITURE, USE SAINT'S SATIN WAX. •

somehow achieving some individuality and some roots. People are giving up lots of rooms, they'll sleep, eat, live, and work in one space, rather than have cubicles that are too constricting. They want a sense of freedom within doors. Because most of our modern housing is bland, innocuous and plain beyond belief, with no interest in it or excitement of spaces, the things that go in it are going to be what make it have any character at all. Textures are important. They hardly exist in architecture now that we have smooth plaster and smooth glass and smooth floors. The texture has to be brought in through furnishings, wall and floor coverings.

People are packing barn boards into their town apartments, working their way to the old brick.

There will be many approaches to achieve texture. Busy pattern we need less and less. Life is full of busy patterns, screeching sounds, mechanical rhythms. We don't need visual counterparts.

SCHWARTZ: It seems to me that time is one of those things we've used badly because we don't understand what it is. We try to use all our time to get something or somewhere. People are revolting against the Monday to Friday job from nine until five. Because the truth of the matter is—and Orientals know and mystics know—that quite often to use time effectively, you get more by just sitting still. And this is what so many people are starting to realize—that time is one

of the rituals that guides what we do. And this is why young people are getting into nature, plants, growing their own food. They appreciate the fact there is a unity in all things and a better way to receive information than through the conventional sense. The most effective use of time might be just to ignore it, and to say to yourself I will not oppress myself, I will not get depressed by the fact that I'm not doing anything at the moment. All intense creativity has to do with intense involvement and intense withdrawal.

If we see withdrawal as a way of not getting caught up in time and its demands on us, then we might start to get hold of new levels of creativity.

And that would be terribly exciting. One of the most incredible by-products of going to the moon is that picture of earth floating all alone in space. I think this changed everybody's view. We suddenly saw that there was this sphere, and we are all hanging on to the side of it, and now we have to mother it. I think this marked the beginning of the ecological revolution. We're all on spaceship earth, searching for new meaning and new ritual. We must attempt to find I-thou relationships, not let ourselves be structured in a competitive situation for goods or for work or labor, but share the pleasures of being each other to the fullest.

LARSEN: I think we'll have less indifference in the future and a better world.

Coming next month:

WONDERFUL CHRISTMAS PRESENTS

Hundreds of them for you,
for the house, for the garden

On your newsstand, October 18