

*Clem Labine's*  
**TRADITIONAL  
BUILDING**  
Historical Products For Today's Professional

J U L Y / A U G U S T 1 9 9 0 V O L . 3 N O . 4 \$ 3 . 0 0

STAIRCASES & PARTS

PAGE 27

ART GLASS

PAGE 7

Bulk Rate  
U.S. Postage  
PAID  
Permit No. 1  
Manchester, N.H.

69A Seventh Avenue, Brooklyn, N.Y. 11217  
Address Correction Requested.

PHOTO: THE DAHLKE STAIR CO.

# HISTORICAL PRODUCTS MARKETPLACE

## SPECIAL FEATURES

*Profile:*

- The Architecture Gene . . . 5
- Art Glass . . . . . 7
- Staircases & Parts . . . . . 27
- Product Literature . . . . . 38
- Siegel's Scratchboard . . . . 39

## Division 2 SITEWORK



IN THE NEWS

U.S.-MADE ENGLISH GARDEN FURNITURE 4

## Division 4 MASONRY

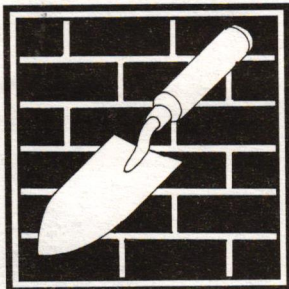

IN THE NEWS

MASONRY CLEANING TIPS . . . . . 4

### RELATED PRODUCT ADVERTISING

- Ahren's Chimney Technique . . . . . 4
- Brickyard . . . . . 4
- Cathedral Stone . . . . . 4
- Lymance International . . . . . 4
- National Supaflu Systems . . . . . 4
- Samuel B. Sadtler Co. . . . . 4

## Division 5 METALS



IN THE NEWS

GOLDEN AGE OF ARCHITECTURAL METAL 6

### RELATED PRODUCT ADVERTISING

- Thermo Materials . . . . . 6

## Division 6 WOOD & PLASTICS

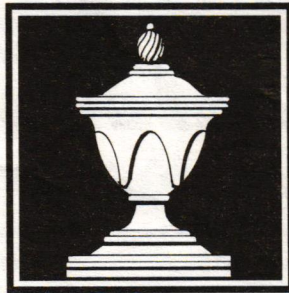

IN THE NEWS

### SPECIAL REPORT: STAIRCASES & PARTS

- STAIRCASES & PARTS INTRODUCTION . . 27
- SOURCELIST . . . . . 28

### RELATED PRODUCT ADVERTISING

- Abatron . . . . . 33
- Albany Woodworks . . . . . 36
- American General Products . . . . . 30
- American Heirlooms, Inc. . . . . 31
- American Heritage Shutters . . . . . 36
- American Ornamental Corp. . . . . 28
- American Stair Builder . . . . . 34
- Anthony Wood Products . . . . . 36
- Architectural Accents . . . . . 36
- Architectural Lathe & Millwork . . . . . 33
- Architectural Stairbuilding . . . . . 27
- Architectural Timber & Millwork . . . . . 27
- Arcways . . . . . 27
- Bare Wood . . . . . 28
- Bear Creek Lumber . . . . . 35
- Beech River Mill Co. . . . . 35
- Blue Ox Millworks . . . . . 30
- Boise Moulding & Lumber Co. . . . . 26
- Bolton Woodturning . . . . . 31
- Boston Turning Works . . . . . 26
- Boston Turning Works . . . . . 31
- Bruce Post Company . . . . . 30
- Cameron Noriega . . . . . 35
- Carlisle Restoration Lumber . . . . . 35
- Chadsworth, Inc. . . . . 33
- Coastal Millworks . . . . . 30
- Conklin's Authentic Barnwood . . . . . 31
- Conservation Services . . . . . 35
- Crawford's Old House Store . . . . . 26
- Creative Woodworking . . . . . 33
- Cross Industries . . . . . 26
- Cumberland Woodcraft . . . . . 26
- Custom Woodturning . . . . . 35
- DHM Cabinet Makers . . . . . 27
- Driwood Moulding Co. . . . . 31
- Dugwood Turners . . . . . 36
- Family Heir-Loom Weavers . . . . . 32
- Fancy Front Brassiere Co. . . . . 30
- Goddard Mfg. Co. . . . . 36
- Goodman Lumber Company . . . . . 29
- Goodwin Lumber Co. . . . . 33
- Hartmann-Sanders Co. . . . . 34
- Heritage Brass Co. . . . . 31
- Iron Shop . . . . . 29
- K-Wood & Logs . . . . . 34
- Keller Associates . . . . . 36
- Mansion Industries . . . . . 30
- Marietta Millworks . . . . . 28
- Maurer & Shepherd Joiners . . . . . 26
- Millwork Specialties . . . . . 33
- National Decks, Inc. . . . . 33
- New England Woodturners . . . . . 26
- Northfield Restorations . . . . . 31
- Partelow Wood Turnings . . . . . 28
- Piedmont Home Products . . . . . 32
- Readybuilt Products . . . . . 31
- Rich Woodturnings . . . . . 36
- Rocca Noto Sculpture Studio . . . . . 29
- Shuttercraft . . . . . 26
- Silverton Victorian Millworks . . . . . 26
- Spiral Manufacturing . . . . . 33
- Spiral Stairs of America . . . . . 32
- Stairways, Inc. . . . . 33
- Steptoe & Wife . . . . . 35
- Vixen Hill Shutters . . . . . 29
- White River Hardwood . . . . . 36
- Wood Factory . . . . . 35
- Woodard Weave . . . . . 29
- Woods Company . . . . . 26
- Worthington Group . . . . . 29

## Division 7 MOISTURE PROTECTION

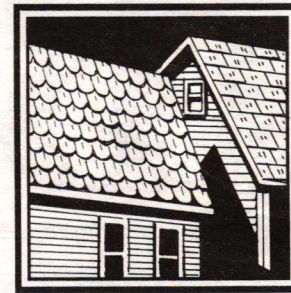

IN THE NEWS

WHITE OAK ROOFING SHINGLES . . . . . 6

### RELATED PRODUCT ADVERTISING

- Donnell's Clapboard Mill . . . . . 17
- Granville Manufacturing Co. . . . . 6
- Oak Crest Manufacturing . . . . . 17
- Sky Lodge Farm . . . . . 17

## Division 8 DOORS & WINDOWS

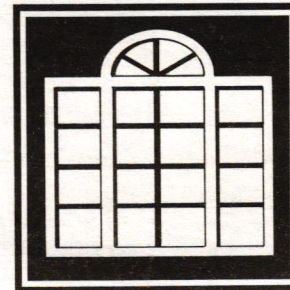

IN THE NEWS

- RESTORATION DOORS & WINDOWS . . . . 19
- EARLY AMERICAN WOODWORK . . . . . 20
- HARD-TO-FIND WINDOW HARDWARE . . 20
- QUICK-SHIP DOOR HARDWARE . . . . . 21
- CUSTOM MAHOGANY DOORS/WINDOWS 21

### RELATED PRODUCT ADVERTISING

- Allied Windows . . . . . 21
- Ball & Ball Hardware . . . . . 20
- Ball & Ball Hardware . . . . . 40
- Creative Openings . . . . . 20
- Hope's Landmark Windows . . . . . 20
- J. E. Smith . . . . . 19
- Kenmore Industries . . . . . 20
- Midwest Architectural Wood Products . . . . . 20
- Taylor Brothers . . . . . 20
- E.P. Titcomb . . . . . 20
- Williamsburg Blacksmiths . . . . . 20
- Woodstone Co. . . . . 21

## Division 9 FINISHES



IN THE NEWS

- MOLDED CORNICES & MEDALLIONS . . . 22
- SCENIC WALLPAPERS . . . . . 23
- PLASTER & FIBERGLASS ARCHWAYS . . . 23

Division 9, continued

**RELATED PRODUCT ADVERTISING**

Above View, Inc.	23
Architectural Sculpture	22
Aristocast Originals	24
Bradbury & Bradbury	24
Chelsea Decorative Metal Co.	24
Color People	22
Composition Group	22
Decorators Supply Corp.	22
Fe Fi Faux	22
Fischer & Jirouch Co.	22
Gary Koepfel Studios	23
J. R. Burrows & Co.	24
John Canning & Co.	24
Kinnari-Silberman Restoration	23
Livermore Wood Floors	24
W.F. Norman	24

**Division 10  
SPECIALTIES**

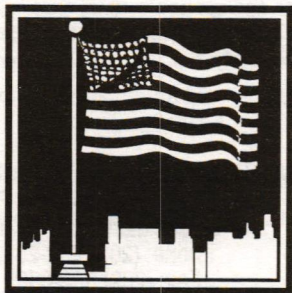

**RELATED PRODUCT ADVERTISING**

Nixalite	25
Smith-Cornell	25

**Division 11  
EQUIPMENT**

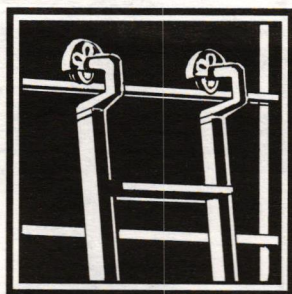

**IN THE NEWS**

ELECTRIC "ICE BOXES"	25
----------------------	----

**Division 12  
FURNISHINGS**

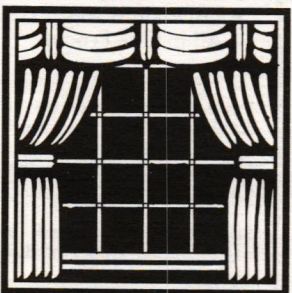

**IN THE NEWS**

**SPECIAL REPORT:  
ART GLASS**

ART GLASS INTRODUCTION	7
SOURCELIST	11

**RELATED PRODUCT ADVERTISING**

Architectural Rarities	15
Artisan Glass Works	16
Beyer Stained Glass	15
Blenko Glass	13
Casola Stained Glass Studio	10
Conrad Schmitt Studios	9
Cummings Studio	15

Division 12, continued

Floral Glass & Mirror	8
Fraser Studio	16
Golden Age Glassworks	16
Great Panes	13
Horton Brasses	13
Jersey Art Stained Glass Studio	14
Marchese & Hamersma	15
Neuwe Daisterre Glas	10
Pike Stained Glass Studio	13
Porcelli Studio	14
Ravenglass	16
Reflection Studios	7
Rohlf's Stained & Leaded Glass	8
Salvage One	10
Shenandoah Studios of Stained Glass	16
Sigstedt Studios	10
Sunburst Stained Glass	10

**Division 14  
CONVEYING SYSTEMS**

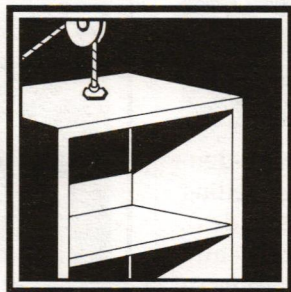

**IN THE NEWS**

STAIRWAY LIFTS	25
----------------	----

**RELATED PRODUCT ADVERTISING**

Whitco/Vincent Whitney Company	25
--------------------------------	----

**Division 15  
MECHANICAL**



**RELATED PRODUCT ADVERTISING**

Bathroom Machineries	25
Restoration Works	25
Vermont Soapstone	25
Watercolors, Inc.	25

**Division 16  
ELECTRICAL**

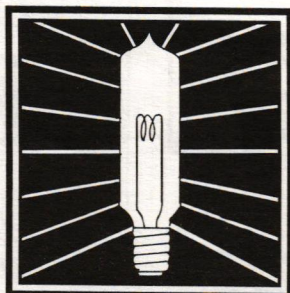

**RELATED PRODUCT ADVERTISING**

Art Directions	37
Authentic Designs	39
Classic Accents	36
Roy Electric Co.	36
Saltbox	39
Sentry Electric	37
Sternberg Lanterns	37
Trimble House	37
Urban Archaeology	37
Victorian Lighting Works	37

CSI DIVISION SYMBOLS: STAN SIEGEL

**letters**

**The End Of Cheap Lumber**

To the Editor:

Here are some observations from the "Heart of the Redwoods."

It's hard to change from the "Old Days" when the forest was so vast and went on forever. Back then, our job was to try our best to meet the demand for lumber with equipment and saw-mills that were horribly slow and took sheer brute force to get ANY production at all. The lumberman had a do or die attitude towards a job that was bred into him, generation after generation.

There were two major changes in the past 25 years that have brought our industry to the precipice we now stand on. The first is technology: It's not *us* any longer — it's the machines that are all-powerful and have such output that suddenly the destruction of the forest is possible.

The second change is the people in charge of the large timber conglomerates. Most aren't lumbermen anymore; they're businessmen interested in short-term profits.

We've got to view the forest not merely as a stand of trees but a total environment. We've got to have the courage to say: "Now look here, you folks that want wood, there's just so much cutting that we're going to be doing this year. And we can't send any more logs, burls, or anything else to Japan unprocessed. We've got our own mills and men to look out for."

We can't clear-cut just because our industry and the Forest Service say it's a better way to log; it's merely a *cheaper* way to log. I feel selective logging can be done easily. I've done it, and I've even logged selectively with High-Lead. It just takes more set-ups. Of course, it's going to mean that the lumber is going to cost more to accommodate these changes, but this is what has to happen.

Builders who are expecting cheap lumber in ever-increasing abundance are in for a rude shock... especially with respect to first-growth redwood. There are initiatives on the ballot in California this year that, if passed, will significantly reduce logging of virgin timber in our state. Similar initiatives are likely in Oregon and Washington.

Managing our forests for long-term sustainable logging is going to mean scarcer, more expensive lumber. But if there are to be forests for our grandchildren, we have no choice.

— Eric Hollenbeck  
Blue Ox Millworks  
Eureka, Calif.

*Clem Labine's*  
**TRADITIONAL BUILDING**

**Historical Products  
For Today's Professional**

69A Seventh Avenue  
Brooklyn, NY 11217  
(718) 636-0788  
FAX: (718) 636-0750

*Editor & Publisher* **Clem Labine**  
*Managing Editor* **Judith Siegel Lief**  
*Contributing Editor* **Eve M. Kahn**  
*Art Director* **Judith Siegel Lief**  
*Advertising Manager* **Susan Littman**  
*Assistant Art Director* **Robin Factor**  
*Circulation Assistant* **Rebecca Friedman**  
*Circulation Assistant* **Tiffany Meertens**  
*Data Security* **Magnolia C. Shepherd**  
*Comptroller* **Barry Kornblum**

A Note To Contributors: TRADITIONAL BUILDING solicits reviews of historical products from building and preservation professionals. A query letter to the editor describing the product and scope of the review is suggested. Photos of outstanding examples of Neo-Traditionalism and Architecture are also sought. While we will be careful of all materials submitted, we cannot be responsible for non-receipt or loss; please keep copies of all materials sent.

TRADITIONAL BUILDING (ISSN 0898-0284) is published bimonthly by Historical Trends Corporation, 69A Seventh Avenue, Brooklyn, NY 11217. Telephone: (718) 636-0788, FAX: (718) 636-0750. Subscription rate to professionals in architecture, construction, and preservation in the U.S. and possessions: \$18/yr. (6 issues). Rate for nonprofessionals and subscribers outside U.S.: \$30/yr., U.S. funds.

Contents of TRADITIONAL BUILDING are fully protected by copyright and must not be reproduced in any manner whatsoever without written permission from the publisher.

© Copyright 1990 by Historical Trends Corporation. All rights reserved.

PRINTED AT THE LIGHTHOUSE PRESS  
Manchester, New Hampshire

TRADITIONAL BUILDING is indexed  
in CONSTRUCTION INDEX.



Division 2  
SITEWORK

ENGLISH STYLING —  
AMERICAN CRAFTSMANSHIP

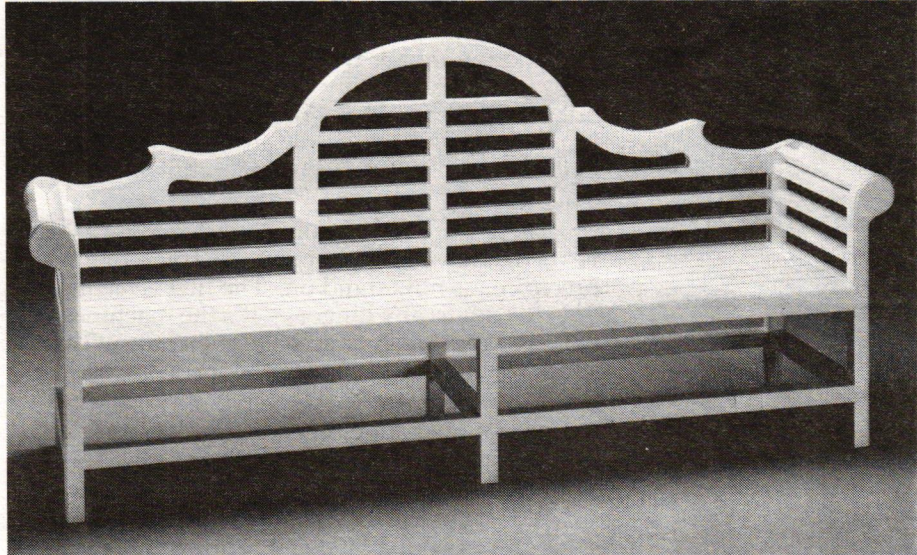

Worthington Group has styled a garden bench after the English classic and named it "Lutyens." Manufactured in their Atlanta factory, the elegant bench measures 88-1/2 in. long, 42-1/4 in. high, and has a seat depth of 22 in. (one size only). Prices are \$1,007 for (white or pickled) painted Cypress or \$1,247 for teak. The Resort Furniture line includes chairs, tables, benches, and planters. Worthington also manufac-

tures architectural detail in high-density plaster (cornice moldings, ceiling medallions, domes, balustrades), wood columns and capitals, and "Classics," which are miniature architectural elements scaled for indoor use (glass also available).

For more information, contact: **Worthington Group, Ltd., PO Box 53101, Dept. TB, Atlanta, GA 30355 (404) 872-1608. CSI# 02800 — JL Or Circle No. 513**

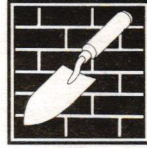

Division 4  
MASONRY

JAHN RESTORATION MORTARS  
for the repair of masonry materials

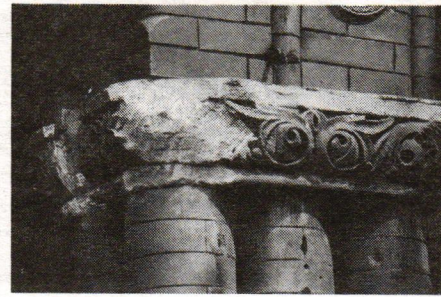

Before



After

■ Specially composed from a cement base to be physically compatible with the material for which it was made; sandstone or limestones, concrete, terra cotta plus several injection-grout mortars.

■ Each material is matched by use of proper size aggregate and coloring agent. Standard mixes are available for most masonry materials. Custom matches can be made when needed.

■ These materials contain NO harmful acrylics, polymers or metal compounds.

■ Tested through 1000 freeze/thaw cycles with no failures.

■ These mortars are mixed with water for use and applied with trowels or can be cast for unit replacement. No layering necessary, can be applied in any thickness.

Call or write for brochure, samples and reference list of projects.

**CATHEDRAL STONE PRODUCTS, INC.**  
2505 Reed Street, N.E.  
Washington, D.C. 20018  
Phone: (202) 832-2633  
Fax: (202) 832-0885

Circle No. 380

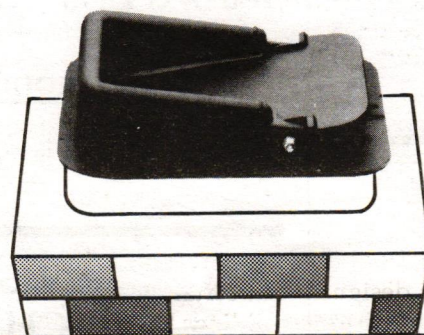

PUT A LID ON  
ENERGY SPENDING

- Easy installation and low cost.
- Fits flue tile sizes: 9"x13", 12"x16", 13"x13", 13"x 18", and 17" x17". Also available: 8"x8" Adaptor which accommodates a 9"x13" Damper.
- Seals in heat and air conditioning for better efficiency.
- Seals out birds and animals.

**LYEMANCE INTERNATIONAL**

P.O. Box 505 • Jeffersonville, IN 47130  
(812) 288-9953 • Fax 812-283-3692

Circle No. 512

A pair of Early 19th Century  
Pennsylvania (King of Prussia Blue)  
**MARBLE MANTELS**

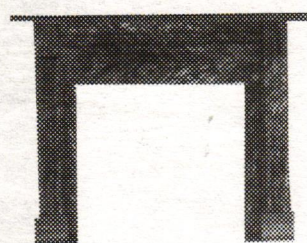

**SAMUEL B. SADTLER** 340 S. 4th Street  
Philadelphia, PA 19106 (215) 923-3714

Circle No. 164

**supaflu™**  
The Ultimate Flue Liner  
For Masonry Chimneys

**Cast-In-Place Lining**

- Seals
- Cures Condensation
- Insulates
- Improves Combustion Efficiency
- Lines & Makes Chimneys Safe
- Impervious to Corrosion
- All in One Process

Tested and Listed by an ASTM and ACIL approved laboratory to UL 103-2,100 F., Canadian ULC-S629-M-1981 and UL Requirements for Non-Metallic Chimney Lining System — 1985.

Supaflu is recognized by the International Conference of Building Officials — Report No. 3937.

**National Supaflu Systems**  
Chimney Lining and Relining

P.O. Box 89 Walton, NY 13856  
(607) 865-7636

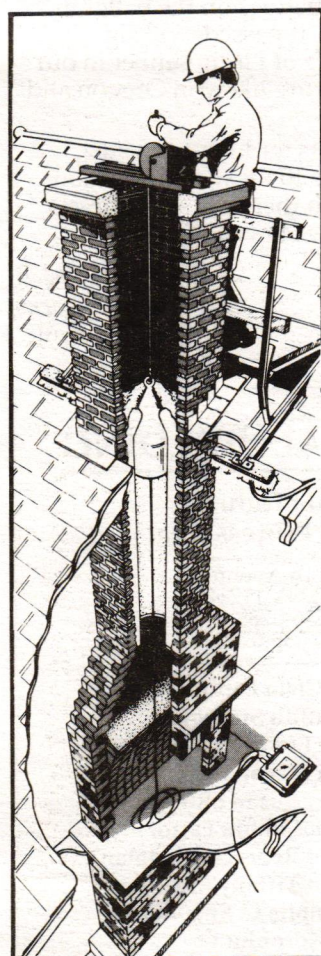

**AHRENS**

Relines/Restores  
Masonry Chimneys

With The ONLY UL Listed, Two-Liner  
Cast-In-Place Masonry Process

- First liner insulates and strengthens
- Second liner seals and protects
- Both are immune to acids and moisture.
- No guess work. Mechanically applied.
- No exterior alterations.
- No metal to corrode.
- Improves heating efficiency —

All for a fraction of the cost of rebuilding!

Dealership network nationwide.  
Call or write for more information.

**AHRENS chimney technique**  
2000 Industrial Ave.  
Sioux Falls, SD 57104

**1-800-843-4417**

Circle No. 244

Build With Pieces of History



Now available in very limited quantities — authentic, decades-old, unused clinker brick. Due to changes in brick manufacture, when these are gone there won't be any more. Write for free literature or send \$10 for price list, color photos, and sample brick. *We do Custom Brick Engraving.*

**The Brickyard**  
P.O. Box A  
Harrisonville, MO 64701

Circle No. 396

CLEANING MASONRY

Few areas of rehabilitation are laced with as much technical jargon, mythology, and misinformation as the treatment of old masonry. Bringing clarity, good sense, and practical how-to information to this mystical domain is the excellent volume, "Keeping It Clean," written by Anne E. Grimmer of the National Park Service.

The 34-pg. manual provides lots of helpful advice on removing exterior dirt, paint, stains, and graffiti from masonry. This is must reading before allowing a contractor to work on any of your masonry buildings.

"Keeping It Clean" (Order No. 024-005-01035-1) can be obtained for \$2.50 from Supt. Of Documents, Government Printing Office, Washington, D.C. 20402. — CL

profile

# Architecture In Their Genes

■ In 1931, Nicholas Holmes, Sr., hung out his shingle in Mobile. Fifty-nine years later, the firm of N. H. Holmes, Architect, is still running — with son Nicholas, Jr., and grandson Nicholas, III, at the helm. Under their stewardship, it has become one of the South's premier preservation firms — while also setting a HABS record.

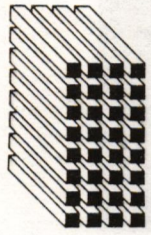

BY CLEM LABINE

If you walk into the offices of N. H. Holmes, Architect, in Mobile, Ala., and ask for "Nick Holmes," you're likely to get a puzzled stare. That's because the receptionist isn't sure whether you're referring to Nicholas Holmes, Sr., the founder of the firm, or Nicholas Holmes, Jr., or Nicholas Holmes, III.

Nicholas, Jr., and Nicholas, III, son and grandson of the founder, are in charge of the firm today. When asked how people solve the nomenclature problem with so many Nicks involved, Nicholas, Jr., says with a chuckle: "People often refer to us as Nick One, Nick Two, and Nick Three."

Nicholas Two and Three both have the quiet, soft-spoken tones that you might expect from gentlemen schooled in Southern etiquette. Though their manner is quiet, their work speaks eloquently for them. Among the current projects of N. H. Holmes, Architect, is the highest-visibility job in the state of Alabama: The \$25-million restoration of the State Capitol in Montgomery. In addition, they are co-managing a design competition for a proposed Mobile County/City Building, as well as designing a dozen smaller projects.

Although the firm has a gilt-edged reputation in architectural preservation, it isn't the company's bread-and-butter. There simply isn't enough preservation work in Alabama to keep a firm busy on historical projects alone. In fact, over the years only about 30% of the billings of N. H. Holmes, Architect, have been generated from preservation and restoration jobs.

## The Old Influences The New

With roughly 70% of their revenue coming from work on new schools, banks, offices, and industrial facilities, the firm's designers can certainly be labeled "contemporary architects." But their work on historic buildings has had a clear influence on their new designs.

"We have a feeling for architectural embellishment," says Nicholas Two, "and that gives our new work a softer, less harsh look than much modern design. We like to think that our new buildings look at home and comfortable in their environment."

Nicholas Three elaborates: "Having a historical perspective makes us suspicious of design fads. We're not trying to put up trendy 'datable' buildings; we strive for a more classic, timeless appeal. For example, by conscious choice we have never designed a building that could be labeled Post-Modern."

Aesthetics aside, there is also a very practical benefit that comes from combining preservation work with a contemporary practice. "When you work with a lot of old buildings," observes Nicholas Three, "you see some very dramatic examples of what works over time and what doesn't. You see types of joints that fail, and the way materials age. I feel our new buildings are based on sound knowledge of practical functioning — not flights of fancy."

The firm's reputation as top restoration architects has had another unexpected consequence: N. H. Holmes, Architect, is the firm most people in southern Alabama think of when there are emergency repairs to be made. One notable example was when Hurricane Frederic struck coastal Alabama with devastating force in September 1979. The firm was requested to manage the hurricane damage repair to all the public schools in Mobile county. A team of architects under Nicholas Holmes, Jr., prepared bid documents and supervised about \$10 million of repair work.

## A Long Corporate Memory

Management consultants define "corporate memory" as the ability of people in an organization to retain information about policies and projects from the organization's earliest years. The inter-generational connections of N. H. Holmes, Architect, give it an unusually long "corporate memory."

One case history shows how this "corporate memory" can come into play: After Hurricane Frederic, the firm was selected to perform architectural work for the repair of Mobile City Hall. The first priority, of course, was to secure the building with temporary walls, roofs, and window closures.

Nicholas Two recalled that the building had been documented by HABS in the 1930's, and so they quickly obtained copies of the drawings. "It was rather spooky," he says. "Son Nicholas the third and I hard at work using HABS drawings made in 1935 by N. H. Holmes, my father." Those old HABS drawings saved the architects a great deal of time and helped avoid further rain damage.

## Setting A HABS Record

Besides heavy involvement with preservation activities on both the state and national level (both, for example, are active in the AIA's Committee on Historic Resources), the family Holmes has achieved a unique distinction: They are the only set of grandfather-father-son architects to have delineated drawings for the Historic American Buildings Survey.

There is a note of gratitude in Nicholas Jr.'s voice when he speaks of the role that HABS has played — both in helping preserve Alabama's architectural heritage, and in helping his father's firm survive. "The depression hit hard in Alabama. My father's architectural practice netted \$1,225.50 in 1931 — and then things *really* got bad! In 1934, the Historical American Buildings Survey was started as a Federal program to get unemployed architects back to work. Under this program, during the mid-1930's my father was busy scurrying through all

*continued on page 18*



Nicholas Holmes, III (left) and Nicholas Holmes, Jr. (right), flank a portrait of Nicholas Holmes, Sr., portrayed in the traditional smock he always wore in the office. (The smock was popular work garb earlier in the century for both architects and painters.)



Division 5  
METALS

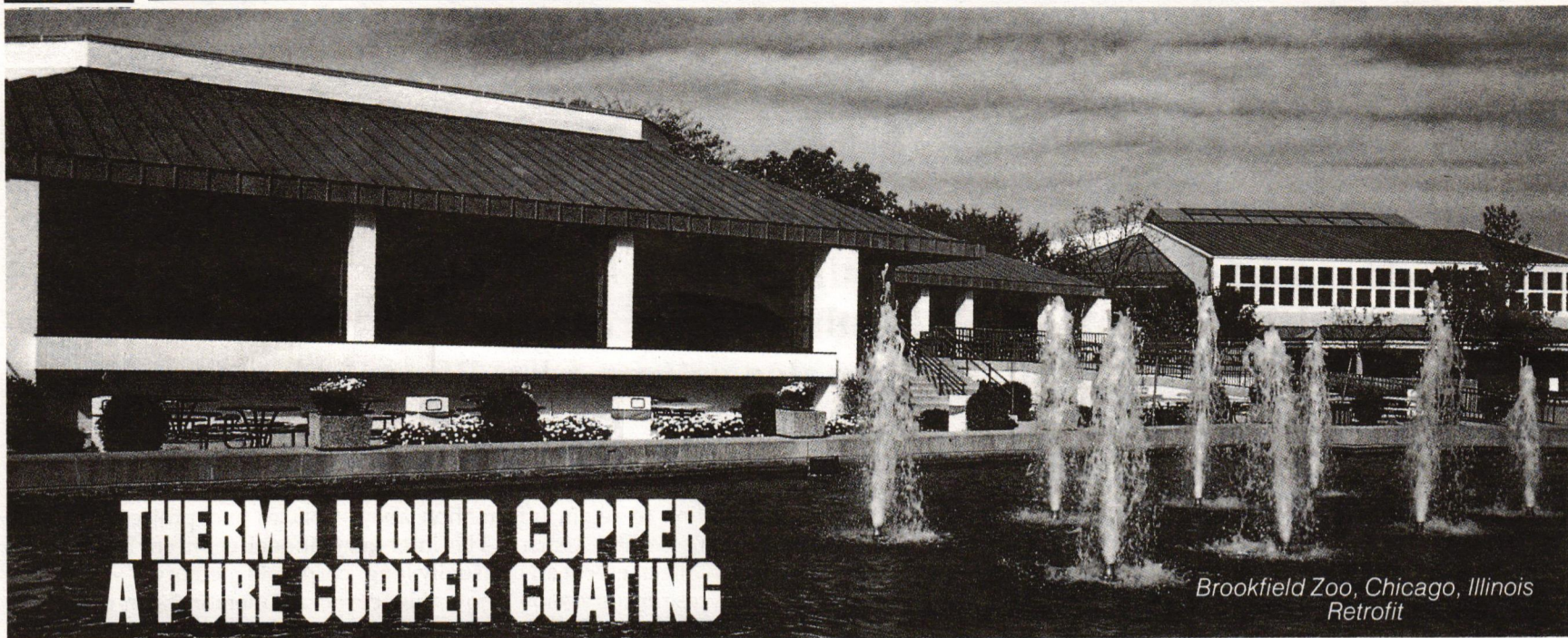

**THERMO LIQUID COPPER  
A PURE COPPER COATING**

Brookfield Zoo, Chicago, Illinois  
Retrofit

Thermo Copper Coating is a unique, inexpensive alternative to copper metal sheeting — providing an attractive, long-life finish without the limitations, expense or problems of more traditional methods.

Specially formulated from acrylic resins and pure ground copper, it cures to form a flexible membrane with the bright, shiny appearance of a new copper penny. It ages with time and exposure to the elements like traditional copper sheeting. And, if preferred, the aging process can be accelerated to provide an attractive patina effect.



Thermo Copper Coating can easily be field-applied to roofs, mansards or walls, and substrates such as wood, metal, masonry, mineral surface roofing, granular and clay emulsion surfaces and composition shingles, or, can be baked on to metal substrates such as aluminum or galvanized metal in factory production.

Call or write Thermo Materials today to learn how you can put Thermo Liquid Copper to work on your next project.



Box 9454, San Diego, CA 92109, 619/272-0061, Outside CA 800/882-7007 Fax: 619/276-0533

Circle No. 464



Division 7  
MOISTURE PROTECTION



**Quartersawn  
Clapboard Siding**

**Quartersawing**  
produces a vertical grain clapboard.

- Twists and warps less
- Wears more evenly
- Bonds paint and stain better

Also featuring...

**Olympic's Machinecoat™  
Exterior Pre-Finish**  
for all types of siding.

Allows finishing prior to installation  
with **10 year warranty:**

- Crack, Peel and Flake Resistant
- Washable without damaging finish
- Non-Yellowing
- No Chalk Washdown
- Paint Film will not Erode

**Granville Manufacturing  
Company, Inc. • Established 1857**  
Granville, Vermont 05747

**802-767-4747**

Call or write for free brochure

Circle No. 417

**New Book:**

**THE GOLDEN AGE OF ARCHITECTURAL IRON**

A just-published book on wrought and cast iron casts a brilliant new light on a time when ornamental iron was an honored citizen of the world of architecture.

With the decline of ornamentalism in the 20th century, the art of producing architectural iron was all but lost. As the author, Diana Waite, points out in her introduction, "Sadly, the extent of what remains reflects as well on the extent of what has been lost." And it is not only the loss of actual pieces Ms. Waite refers to, but also to the loss of technology. Some cast iron objects that were produced routinely in the late 19th century can only be reproduced today at extraordinary expense — if at all.

Ms. Waite shows us both the ways that wrought and cast iron were manufactured and how they were used architecturally. There's also a very useful chapter on how to preserve and restore ironwork, written by John G. Waite. The book is lavishly illustrated, both with photos of surviving ornamental iron and with pages from period ironwork catalogs. Most of the photos and manufacturing histories are taken from the Albany-Troy, N.Y., area. . . but the examples are typical of ironwork throughout much of the U.S.

Students of architectural iron will want this volume, of course. But with today's reviving interest in ornamental iron, this book is also a valuable design source for anyone working in restoration or traditionally styled new construction.

"Ornamental Ironwork" is 142 pages, softbound. It can be ordered for \$22.45 (ppd.) from Mount Ida Press, 4 Central Ave., Dept. TB, Albany, NY 12210. — CL

**WHITE OAK SHAKES WON'T  
RATTLE OR ROLL**

Oak Crest Manufacturing makes three kinds of mature white or chestnut oak roofing shingle: (1) Smooth-sawn shingle, tapered, smooth on top and bottom, uniform, for a tight seal; (2) Split-sawn shingle, tapered, smooth on bottom, split on top; and (3) Handsplit shakes, split to natural grain.

Trevor McKissick, V.P. of Oak Crest, claims several advantages of white oak over red cedar:

**Moisture Resistance:** White oak possesses tylosis, a natural structural compound, which repels water. The amount of water-repelling resin in red cedar exists in proportion to its age — the older the tree, the more resin — so the younger trees that are being used today are not holding up.

**Aesthetics:** The weathered oak shingles turn silvery grey and lend themselves well to restorations.

**Longevity:** The white oak shakes and shingles are claimed to last 40-50 years, although there's documentation of roofs lasting longer. Oak Crest gives a 20-year unconditional guarantee on their product.

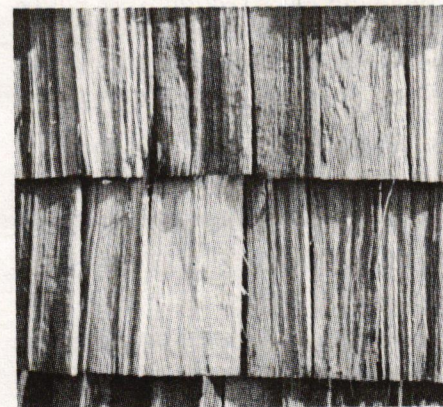

Current run-of-the-mill cedar is lasting about 12 to 15 years, says McKissick. (Longer lasting premium-grade old-growth cedar is still available but becoming scarce.)

**Price:** White oak is about 1-1/2 times the cost of premium-grade red cedar. For example, a square (100 sq. ft.) of handsplit shake at 18 in. is \$365. Smooth sawn is \$210 a square. Standard lengths are 18 and 24 in..

Contact: **Oak Crest Manufacturing, P.O. Box 128, Dept. TB, Jonesborough, TN 37659 (800) 678-3145.** CSI# 07300 — JL Or Circle No. 365  
Division 7 continues on page 17

Division 12  
FURNISHINGS

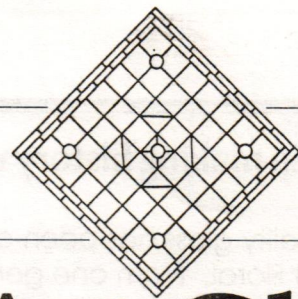

# The Sparkling World Of Art Glass

❖ by Eve M. Kahn



Art glass is one of the oldest architectural art forms: It first appeared on Christian basilicas in the 3rd and 4th centuries. It blossomed on the great Gothic cathedrals of the 12th and 13th centuries, and then traveled to America in the mid-19th century, where designers revolutionized it. And many innovations still come from the U.S.

Etched, beveled, and carved glass first appeared on American homes in the mid-19th century, while churches of the era typically imported richly-colored and painted windows from Europe. Toward the end of the century, stained glass became a residential necessity, and even modest dwellings contained at least a stained-glass transom or a stairway lite, as did many small commercial buildings. Major American glass studios appeared, making opalescent and other spectacular windows for churches and elegant homes. The popularity of these ornate designs and colors waned in the 1920's, and not until the 1970's did art glass make a residential and commercial comeback. Churches, however, have continued to use art glass, typically in brilliantly colored, abstract forms.

Like so many reborn traditional crafts, stained glass has now become almost commonplace. An art-glass studio occupies a storefront on many small-town Main Streets, and traditional- and not-so-traditional homes around the country boast beveled, etched, leaded, or stained panels, usually surrounding the entries. Glamorous hotels, casinos, and shopping malls also commission art glass. Restoration is, of course, big business as well, because the thousands of windows installed between 1870 and 1920 now need repair. New glass types have been invented, such as dichroic glass (it changes color as you move around), and old glass formulas have been revived, including iridized glass, on which the surface resembles a soap bubble.

A few words about protective glazing, one of the biggest headaches in restoring or building large stained-glass panels: In the 1970's, it seems every urban church nervously tacked Lexan panels over its windows. Lexan does not break, so experts still agree that it suits neighborhoods prone to heavy van-

dalism. However, Lexan's drawbacks are substantial. It covers a window's intricate texture with a matte, 'blind' surface. It can yellow and require replacement after a few years. And it is more expensive than glass. The best alternatives are leaded panes (see The Greenland Studio's solution, page 9) or sheets of tempered or laminated glass.

For information on choosing an art-glass studio and specifying windows, the Stained Glass Association of America publishes a free brochure: **SGAA, 4050 Broadway, Ste. 219, Kansas City, MO 64111 (800) 888-7422**. Professionals involved in large restoration projects may want to send \$5 for Julie Sloan's booklet, "Restoring Stained Glass: Terms, Potential Problems, & Suggested Approaches" (available through **McKernan Satterlee Assocs., Tonetta Lake Rd., Brewster, NY 10509 (914) 278-2187**). Ms. Sloan is a consultant who documents stained glass, produces specifications, estimates costs, and oversees restoration. ❖

## Who's In This Special Report

There are several hundred art glass studios in the U.S., so to publish a list of only 28 obviously requires some arbitrary decisions. We based our selections on: (1) Companies that will execute traditional designs and/or restoration; (2) Companies that seemed particularly interested in serving the needs of professionals involved with historical work; and (3) Companies that supplied us with sufficient information about their capabilities.

The art-glass studios listed in the SourceList on pages 11 and 12 fall into two basic categories: Those that opened in the '70's in response to stained glass's rebirth, and those that have been around since its turn-of-the-century heyday. Some concentrate on restoration work while others prefer new projects. Most are small, typically employing less than a dozen people. Some perform all work in house, while others send glass out to be bent, beveled, or etched. And all possess large inventories of old and new glass types.

If you need information immediately, call or write these companies directly. We've provided all contact information in the SourceList. (Please mention TRADITIONAL BUILDING.) If you simply need information to update your files, you may find it more convenient to use the enclosed Product Information Card or the Form on page 38.

## Inherited Art Glass

Michael Padovan grew up in the stained-glass business, helping his father. "He put me to work cementing windows," Michael recalls. "I resisted at first, and then I grew to love it." He has run Jersey Art Stained Glass Studio for 19 years, producing windows mainly for restaurants, homes, and churches.

Two recent projects show his versatility: He built a variety of Tiffany-style Mediterranean landscape windows (shown) for a San Juan restaurant, and for a New Jersey banquet hall he assembled a series of Prairie School beveled- and clear textured-glass panels.

For more information on Jersey Art Stained Glass Studio, see the pullout SourceList in this section. —EMK



## A GLASS ACT

William J. Pike worked for Tiffany in New York City before founding his own studio in Rochester, N.Y., in 1908. "We come from a great heritage," says Pike's grandniece, Valerie O'Hara Murray, who now runs the firm with her father James O'Hara as consultant.

Most of their work is local and ecclesiastical; shown is one of six triple-lancet windows that Pike Stained Glass produced for an Avon, N.Y., church. They also design and repair commercial and residential projects, including a pair of 6-by-10-ft. Victorian skylights for a Rochester steak house and 32 etched-glass panels for a ski

lodge in Swain, N.Y.

For more on Pike Stained Glass Studios, see the SourceList. —EMK

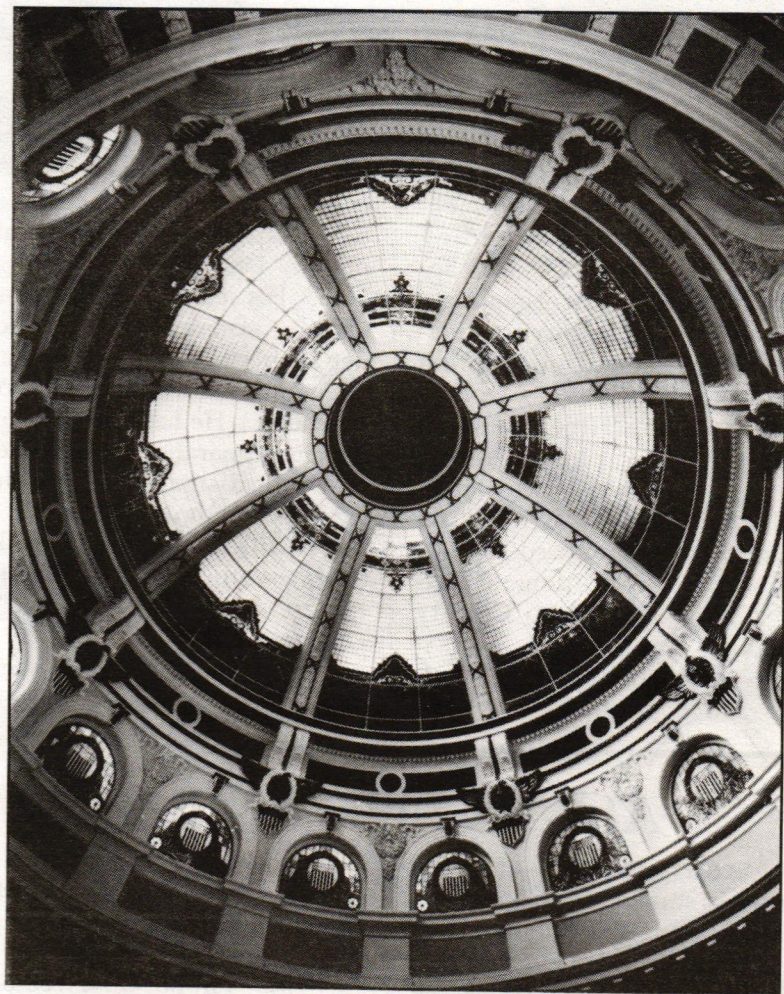

REFLECTION • STUDIOS

RESIDENTIAL • COMMERCIAL  
STAINED GLASS ART & RESTORATION

1418 62ND ST. EMERYVILLE, CA  
(415) 652-4884

SAN MATEO COUNTY COURTHOUSE RESTORATION

Circle No. 461

**We've been making history with our glass.**

Making quality glass has been a time-honored tradition at Floral. From one generation to the next our glass has been filling the need for the finest windows and doors.

Remember, Floral Glass in Hauppauge, NY, and Cheshire, Ct. provides the superior insulating glass - INSULA® in custom sizes, shapes, with muntin bars; all with a 10-year written warranty; annealed, tempered, spandrel (painted) glass custom-colored. And, we can temper glass up to an incredible 96"x178" and ship it anywhere in the U.S.

Quality glass is more than a product at Floral . . . it's a tradition.

Floral Glass & Mirror, Inc.  
895 Motor Parkway  
Hauppauge, NY 11788  
516/234-2200; or 800/647-7672;  
FAX: 516/234-8866.

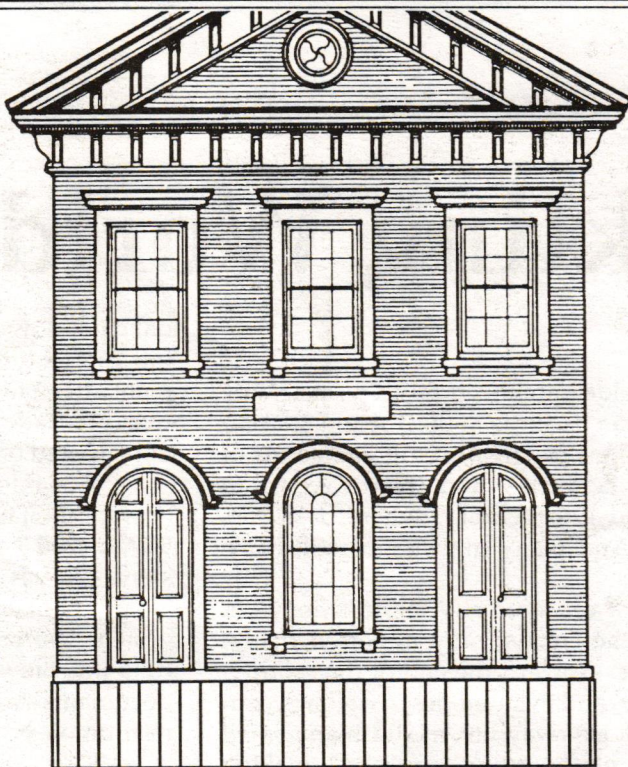

**FLORAL**  
Glass & Mirror, Inc.

Circle No. 397

**THE WORLD'S  
FINEST  
STAINED AND  
FACETED GLASS**



America's Foremost  
Stained-Glass  
Conservators

**ROHLF'S**  
STAINED & LEADED GLASS  
783 So. 3rd Ave., Mt. Vernon, N.Y. 10550  
(914) 699-4848 (212) 823-4545  
Phone or write for Free brochure/estimate

Circle No. 462

**The Don of Domes**

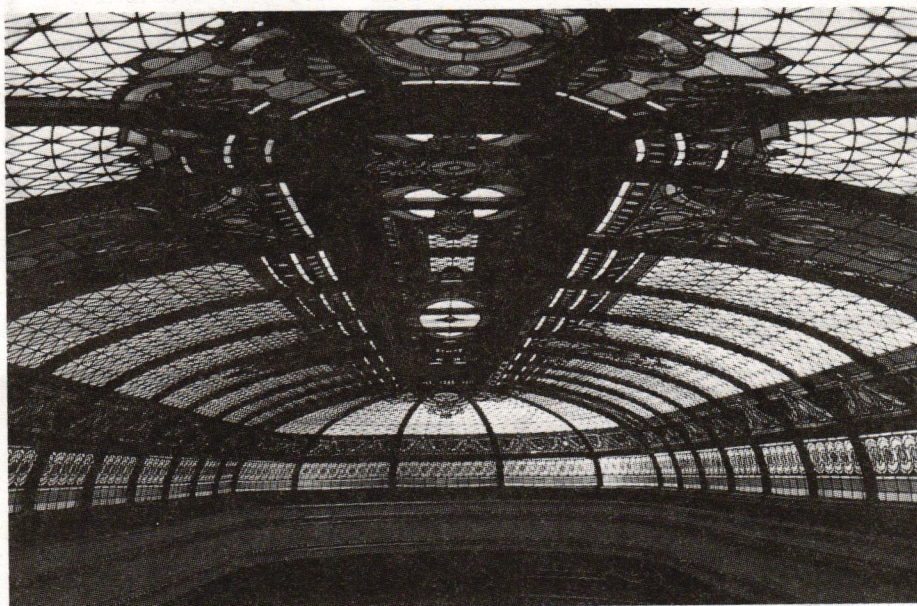

Allen Dragge worked for Buckminster Fuller before founding Reflection Studios in 1980, and apparently the patron saint of geodesics had an effect on Dragge's current efforts: He specializes in restoring stained-glass domes. He's worked on them for the Hibernia Bank (shown), Olympic Club, Carnegie Library, and Sheraton Palace ("about the size of a football field," he reports), all in San Francisco. He also rebuilt the 38,240-piece dome at Redwood City's San Mateo County Courthouse.

None of these projects suffered much damage in the

earthquake. "The courthouse lost two parapets and 40% of the interior plaster," Dragge says, "but the dome held." His secret: A suspension system that absorbs shocks but doesn't detract from the dome's appearance. (He won't share more details of this invention.) He has also developed a rigging apparatus that enables his crews to dismantle and re-install skylights without filling the room below with scaffolding. "It's like the daring young man on the flying trapeze — with a safety net," says Dragge.

For more on Reflection Studios, see the SourceList in this section. —EMK

**ALWAYS LEARNING**

Marchese & Hamersma is a 57-year-old art-glass studio that's belonged to John and Richard Civitello since 1984.

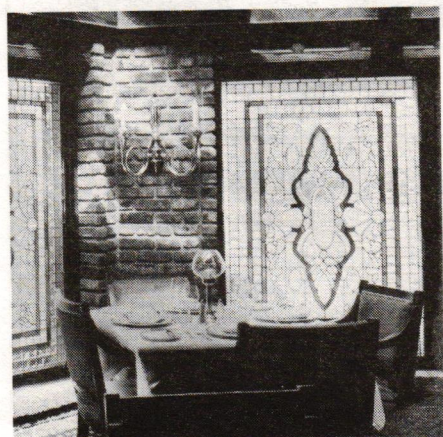

The father-and-son team have about 85 years' glass experience between them. "Eventually you get to be an old master craftsman," says son Richard. "I'm not there yet, but my dad is, and even he's still learning."

Their specialty is ecclesiastical and residential work, mainly in the mid-Atlantic area. "We'll do traditional, abstract, Byzantine, Edwardian . . . whatever," Richard says. Shown are some sparkling beveled and stained-glass units they installed in a Carlstadt, New Jersey, restaurant.

For more information on Marchese & Hamersma, see the pullout SourceList in this section. —EMK

**JEWELLED GLASS**

Few stained-glass artisans press their own jewels anymore, but Val Sigstedt still does. Proprietor of Sigstedt Studio, he's been studying glass since he apprenticed with a master in 1948. He's best known for his jewel-filled pieces for Tavern on the Green in New York and Maxwell's Plum in San Francisco, but in the past year he's ventured far from those convivial places.

Mr. Sigstedt designed and built five stained-glass murals for the Graduate Hospital Imaging Center in Philadelphia (shown). Patients often spend up to an hour in rooms there, motionless, while machines study them. Sigstedt's works incorporate peaceful foliage, landscapes, and jewel-studded rivers with interpretations of the images the Center's machines produce — from single cells to brain vessels. He also accepts residential commissions, and espe-

cially enjoys designing Tiffany-style windows so well that "they're indistinguishable from the real thing."

For more on Sigstedt Studio, see the pullout SourceList. —EMK

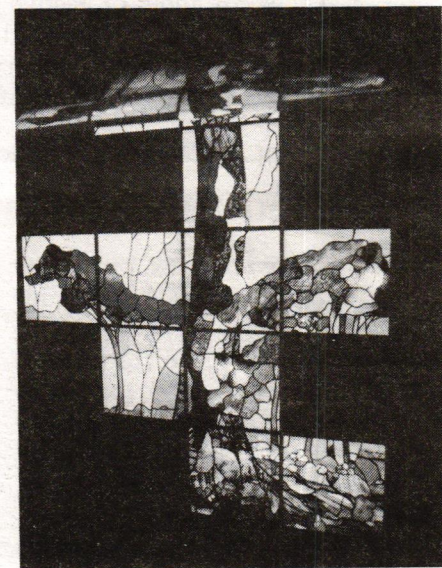

**Glass from Down Under**

Fraser Studio opened in 1988, after David Fraser had apprenticed for ten years with a Yugoslavian-trained stained-glass master. This spring, Fraser received one of his most intriguing assignments so far; it came, literally, from underground. A local congregational church discovered six geometric c.1870 stained-glass windows buried in its basement.

"They were taken out when the church was remodeled in 1927

and then forgotten," Fraser says. "The Gothic frames are 13 ft. tall and only a little decayed, and the glass is pristine." He plans to restore the windows so that the church can sell them (contact him for prices and other details). Fraser also undertakes new work, mainly residential and ecclesiastical.

For more information on Fraser Studio, see the pullout SourceList in this section. —EMK

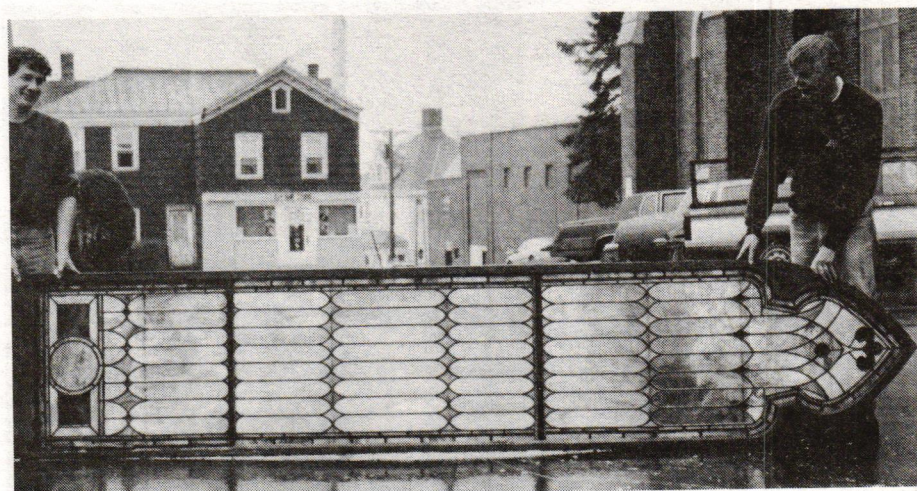



## ENGINEERING SKILLS

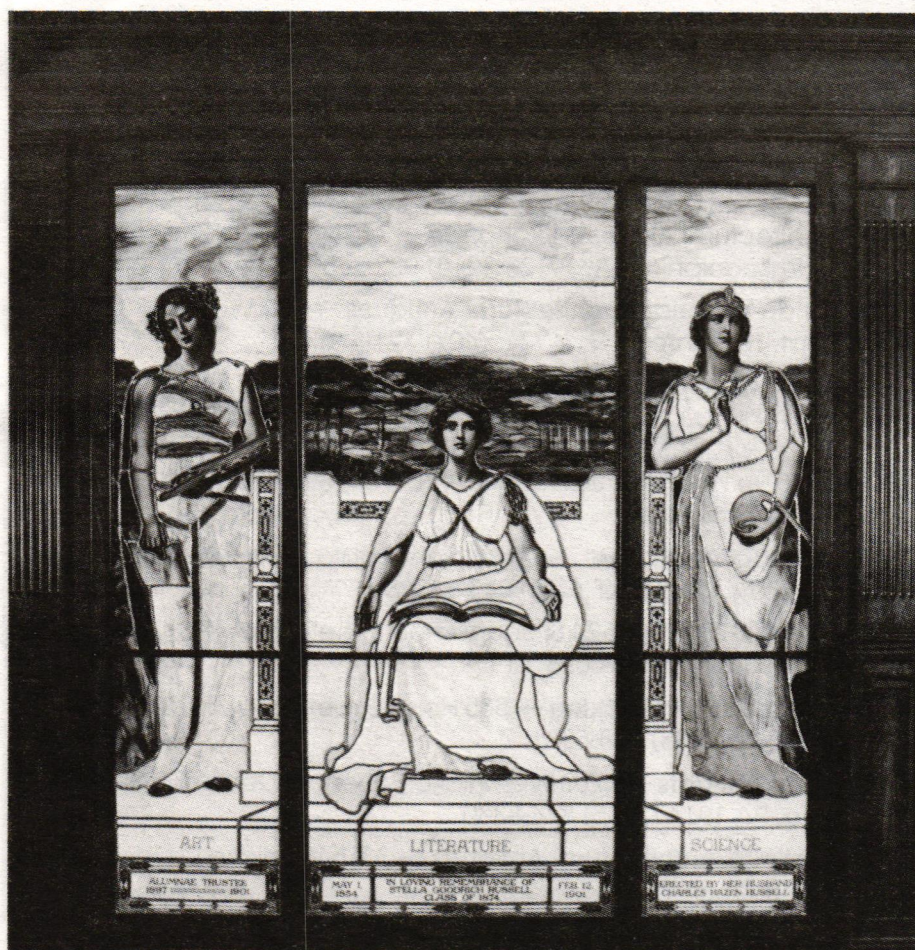

Joseph and Richard Lamb may never have become as famous as their contemporaries, John LaFarge and Louis Tiffany, but the Lambs may also have built a better window. "They came to the business with a working knowledge of glass," says Donald Samick, who bought Lamb Studios from the family in 1970. "LaFarge and Tiffany were painters first. The Lambs knew how to engineer a window that would last. I've restored a

number of their works; I admire them, and I try to emulate them." He recently rebuilt the 1905 Lamb work shown for Wells College.

Samick has adapted the company to the modern world "mainly in the business end," he says. For design ideas, clients can sift through stacks of the Lambs' original sketches.

For more information on Lamb Studios, see the pullout SourceList in this section. —EMK



Stained Glass Restoration  
Sacred Heart Church, University of Notre Dame, South Bend, Indiana

### Conrad Schmitt Studios Inc.

SINCE 1889

Restoration • Renovation • Stained Glass  
Stained Glass Restoration • Etched Glass • Faceted Glass • Murals

Bernard O. Gruenke  
Bernard E. Gruenke

2405 S. 162nd Street, New Berlin, WI 53151  
Telephone: (414) 786-3030 FAX: (414) 786-9036

Circle No. 453

## Working With The Greats



Greenland Studio's resume is impressive. They have restored dozens of Frank Lloyd Wright, John LaFarge, and Tiffany windows. For museums around the country, they have designed art-glass exhibits and conserved windows up to 600 years old (shown is a c.1900 work they restored for the Virginia Museum of Fine Arts). And in 1984 they established an architec-

tural woodworking division, which has rebuilt hundreds of wood window frames for historic buildings on the East Coast; it is currently working on the South Street Seaport Museum.

Their most demanding restoration projects at the moment include the c.1913 Coty building's facade in Manhattan—a three-story slab of Lalique cast glass and steel—and the rotunda at New York City's Municipal Building.

Owner Mel Greenland divides his time between Greenland's Manhattan headquarters and an in-house workshop at the Church of St. Ann and the Holy Trinity in Brooklyn, whose 60 c.1847 windows were the first complete figural stained glass window ensemble created in the U.S. One of Greenland's most difficult tasks there was choosing protective glazing: "We didn't want the 'blind eye' look of Lexan or of a single cover sheet, and we wanted to uncover the Gothic tracery. So we borrowed an idea from

Canterbury Cathedral: We used diamond-paned hand-blown glass and fitted it very close to the tracery. You can see the diamond pattern from inside on a sunny day, but it's not overbearing, and the outside looks so graceful."

For more information on The Greenland Studio, see pullout the SourceList in this section. —EMK

## Wagnerian Windows



In ten years of restoring ecclesiastical art glass, Joseph Beyer of Beyer Stained Glass has learned about the different types that came to America in the mid-19th century. "Catholic and Lutheran churches tend to have German windows, and Episcopal churches often have English windows," Beyer says. "The styles are very different. The English ones have a William Morris/Arts and Crafts feeling, while the German ones are almost Wagnerian: They're overblown, with big-breasted women and heavy chiaroscuro painting."

Beyer can repair and reproduce all kinds of windows; he

rebuilt the church triptych (shown), which included painted faces, rippled glass, and up to three layers of plating. The studio also works on new commercial and residential projects. In progress is an etched-glass panel depicting movie stars, which will hang near a popcorn booth at a Philadelphia theater.

"We prefer to get involved during the design stage," Beyer says. "We can help architects translate scribbles into specs—we know what's a good idea and what's impossible with glass."

For more about Beyer Stained Glass, consult the SourceList. —EMK

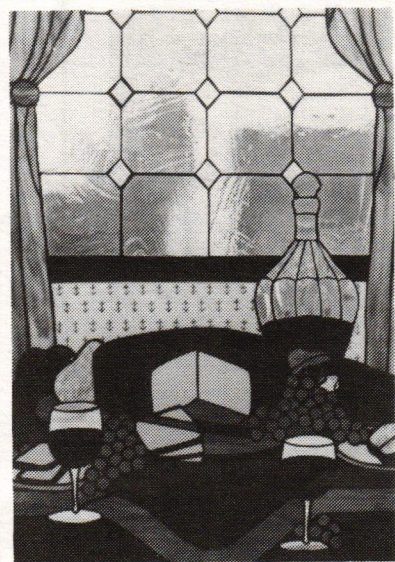

## Create An Atmosphere!

**Original custom designs to your specifications**

- Stained Glass
- Beveled Glass
- Etched Glass
- Mirrors
- Restorations
- Storm Windows and Doors
- Custom Woodworking and Framing
- Specialty Contracting

### Newe Daisterre Glas

13431 Cedar Road Cleveland Heights, Ohio 44118  
(216) 371-7500

20 Years of Experience & Quality Service

Circle No. 459

### THE MIDWEST'S LARGEST SOURCE FOR ARCHITECTURAL ARTIFACTS

Housed in an 85,000 square foot space, Salvage One's inventory consists of 11,000 interior and exterior doors and entryways, 1,200 fireplace mantels in wood, marble, slate and iron,

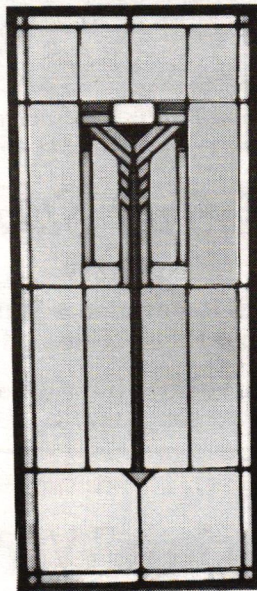

Prairie School window, 42" x 19 1/4"

period decorative hardware, iron fencing, pedestal sinks and tubs, stained and beveled glass, terracotta and garden statuary, period bars, cabinetry, paneled rooms and much more.

### SALVAGE ONE ARCHITECTURAL ARTIFACTS

1524 South Sangamon Street, Chicago, Illinois 60608 Telephone (312) 733-0098 FAX (312) 733-6829  
Tuesday-Saturday, 10:00 a.m.-5:00 p.m.

We are always interested in acquiring fine architectural property.

Circle No. 499

### SUNBURST STAINED GLASS CO

"If it ain't broke, don't fix it" but if it's stained, etched, or beveled glass and it's broke - call us

**812-853-0460**

20 W JENNINGS NEWBURGH IN 47630

Circle No. 465

### SIGSTEDT STUDIO ORIGINAL STAINED GLASS TO EXACTING TASTE

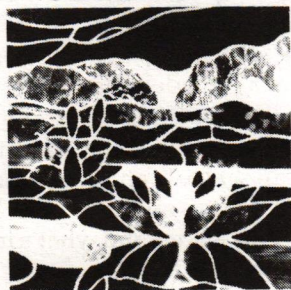

Box 263, Point Pleasant, PA 18950  
tel: 215/297-5924; fax: 215/297-0210

Circle No. 500

### Casola Stained Glass Studio



- Architectural Stained Glass
- Decorative Glass
- Custom Designers

11000 Metro Pkwy., Suite 11  
Ft. Myers, FL 33912

1-813-939-0055

Circle No. 452

## SOURCES FOR ANTIQUE ART GLASS

Most of the art glass studios included in our SourceList have stocks of antique art glass panels for sale as well as new glass. In addition to art glass studios, numerous architectural salvage outlets stock greater or lesser collections of antique art glass. Listed below are a few architectural salvage dealers who are known by the editors to carry a fairly extensive selection of antique art glass:

- **Architectural Antiques Exchange** — 715 North 2nd Street, Dept. TB, Philadelphia, PA 19123 (215) 922-3669
- **Florida Victorian Architectural Antiques** — 901 West First Street, Dept. TB, Sanford, FL 32771 (407) 321-5767
- **Great American Salvage** — 34 Cooper Square, Dept. TB, New York, NY 10003 (212) 505-0070. Other showrooms: Montpelier, VT (802) 223-7711; New Haven, CT (203) 624-1009; Sag Harbor, NY (516) 725-2272; Jacksonville, FL (904) 396-8081; Middleburg, VA (703) 687-5980
- **Ohmega Salvage** — 2407 San Pablo Avenue, Dept. TB, Berkeley, CA 94702 (415) 843-73368
- **Salvage One** — 1524 S. Sangamon Street, Dept. TB, Chicago, IL 60608 (312) 733-0098
- **United House Wrecking** — 535 Hope Street, Dept. TB, Stamford, CT 06906 (203) 348-5371
- **Urban Artifacts** — 4700 Wissahickon Avenue, Dept. TB, Philadelphia, PA 19144 (215) 844-8330
- **Westlake Architectural Antiques** — 3315 Westlake Drive, Dept. TB, Austin, TX 78746 (512) 327-1110

## YE OLDE GLAS SHOPPE



Newe Daisterre Glas (middle English for "morning-star glass") wears many hats. They can etch, bevel (shown), and slump glass in house; they can mill wood; and they often supervise the installation of their own and other people's stained glass.

Owner Alfred Brickel will not use Lexan: "Even the improved formulas don't last more than five years," he says. He recently installed some tempered-glass storm windows

on St. John's Cathedral in Cleveland. "To match the sandstone, we baked white sand into the aluminum frames," Brickel says. "When the sandstone surface ages, the frames will too." Another current project is the rebuilding of some Tudor diamond-paned windows at an Ohio house built in 1475 (yes, 1475; it was shipped here from England.)

For more about Newe Daisterre Glas, see the SourceList. —EMK

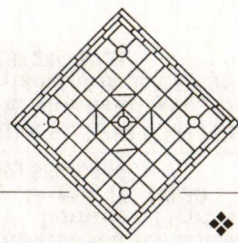

# TRADITIONAL BUILDING'S ART GLASS SourceList

CSI# 12100

❖ BY EVE M. KAHN

COMPANY	LITERATURE	Stock Designs/ Sizes	Beveled	Etched/Engraved	Carved/Cut	Slumped/Bent	Stained/Painted	% Restoration	No. of Employees
Artisan Glass Works 5700 Bellona Ave., Dept. TB Baltimore, MD 21212 (301) 435-0300	Free Circle No. 450		×	×	×	×	×	60%	5
Beyer Stained Glass 6915 Greene St., Dept. TB Philadelphia, PA 19199 (215) 848-3502	Free Circle No. 451			×	×		×	60%	4
Boulder Stained Glass Studio 1920 Arapahoe Ave., Dept. TB Boulder, CO 80302 (303) 449-9030	Free		×	×	×	×	×	15%	4
Casola Stained Glass Studio 11000 Metro Pkwy., Suite 11, Dept. TB Ft. Myers, FL 33912 (813) 939-0055	Free Circle No. 452		×	×	×	×	×	25%	4
Conrad Schmitt Studios 2405 S. 162nd St., Dept. TB New Berlin, WI 53151 (414) 786-3030	Free Circle No. 453		×	×	×	×	×	50%	11
Cummings Studios Box 427, Dept. TB North Adams, MA 01247 (413) 664-6578	Free Circle No. 454		×	×	×	×	×	60%	13
Jack Cushen Studio 122 Clinton St., Dept. TB Hoboken, NJ 07030 (201) 420-9008	Free		×	×	×	×	×	80%	14
Fraser Studio 3 South St., Dept. TB Middletown, NY 10940 (914) 344-5277	Free Circle No. 455		×	×	×	×	×	65%	3
Golden Age Glassworks 339 Bellvale Rd., Dept. TB Warwick, NY 10990 (914) 986-1487	Free Circle No. 28		×	×	×	×	×	30%	4
Great Panes 8069 Main St., Dept. TB Ellicott City, MD 21043 (301) 461-9336	Free Circle No. 456	×	×	×	×	×	×	25%	5
The Greenland Studio 147 W. 22nd St., Dept. TB New York, NY 10011 (212) 255-2551	Free		×	×	×	×	×	75%	9
Lyn Hovey Studio 266 Concord Ave., Dept. TB Cambridge, MA 02138 (617) 492-6566	Free		×	×	×	×	×	25%	9
Jersey Art Stained Glass Studio 603 S. Broad St., Dept. TB Elizabeth, NJ 07202 (201) 353-1318	Free Circle No. 457		×	×	×	×	×	50%	4
Kraatz Russell Glass RFD 1, Box 320C, Dept. TB Canaan, NH 03741 (603) 523-4289	Free	×					×	0%	2

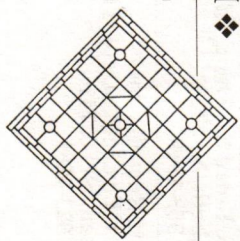

# TRADITIONAL BUILDING'S ART GLASS SourceList

CSI# 12100

❖ BY EVE M. KAHN

COMPANY	LITERATURE	Stock Designs/ Sizes	Beveled	Etched/Engraved	Carved/Cut	Slumped/Bent	Stained/Painted	% Restoration	No. of Employees
Lamb Studios Box 291, Dept. TB Philmont, NY 12565 (518) 672-7267	Free		✗	✗	✗		✗	45%	10
Louisville Stained Glass 4781 Paoli Pike, Ste. 2, Dept. TB Floyds Knobs, IN 47119 (812) 923-7345	Free		✗	✗		✗	✗	35%	5
Marchese & Hamersma 255 Crooks Ave., Dept. TB Clifton, NJ 07011 (201) 340-7575	Free Circle No. 458		✗	✗	✗	✗	✗	50%	5
Melotte-Morse Stained Glass, Inc. 213 S. 6th St., Dept. TB Springfield, IL 62701 (217) 789-9523	Free		✗	✗	✗		✗	75%	5
Newe Daisterre Glas 13431 Cedar Rd., Dept. TB Cleveland Heights, OH 44118 (216) 371-7500	Free Circle No. 459		✗	✗	✗	✗	✗	40%	9
Pike Stained Glass Studio 180 St. Paul St., Dept. TB Rochester, NY 14604 (716) 546-7570	Free Circle No. 460		✗	✗	✗	✗	✗	50%	7
The Porcelli Studio 64 Woodstock Dr., Dept. TB Newtown, PA 18940 (215) 860-9947	Free Circle No. 497		✗	✗	✗	✗	✗	5%	2
Reflection Studios 1418 62nd St., Dept. TB Emeryville, CA 94608 (415) 652-4884	Free Circle No. 461		✗	✗	✗	✗	✗	95%	12
Rohlf's Stained & Leaded Glass 783 S. 3rd Ave., Dept. TB Mt. Vernon, NY 10550 (914) 699-4848 or (212) 823-4545	Free Circle No. 462		✗	✗	✗		✗	50%	30
Savoy Studios 611 N. Tillamook, Dept. TB Portland, OR 97227 (503) 282-5095	Free		✗	✗	✗	✗	✗	5%	9
Shenandoah Studios of Stained Glass Box 1468, Dept. TB Front Royal, VA 22630 (800) 950-1415	Free Circle No. 463		✗	✗	✗	✗	✗	66%	48
Sigstedt Studio 7433 Ferry Rd., Dept. TB Point Pleasant, PA 18950 (215) 297-5924	Free Circle No. 500			✗	✗	✗	✗	33%	6
Sunburst Stained Glass 20 W. Jennings, Dept. TB Newburgh, IN 47630 (812) 853-0460	Free Circle No. 465		✗	✗	✗	✗	✗	33%	12
Willet Stained Glass Studios 10 E. Moreland Ave., Dept. TB Philadelphia, PA 19118 (215) 247-5721	Free		✗	✗	✗		✗	40%	25

## Unaccountable Glass



When she's not building new art-glass windows, Barbara Arrindell of Golden Age Glassworks restores and sells antique pieces. "I study them, too," she says. "I've learned a lot about using color and texture. The old craftsmen could even use ordinary rippled shower glass and have it look beautiful; they'd put strips of it into a design and create a play of clear textures."

Working mainly on churches and homes, Ms. Arrindell can employ traditional styles ranging from Middle Eastern to Prairie. Shown is a magnolia-tree window she installed in a Connecticut residence. She has access to expert glass painters and bevelers, and saves all the design work for herself. "It's like solving giant puzzles," she says. "I never got enough of that as a kid. If I had, I'd be an accountant now."

For more information on Golden Age Glassworks, see the pullout SourceList in this section. —EMK

Artistic Director, and 3rd generation craftsman, Valerie O'Hara Murray continues the legacy of quality established by her predecessors; her father, James O'Hara and her great uncle, William Pike. Valerie's talents, in taking a fresh and innovative approach to your environment, guarantees you a unique design. Whether you wish to create a new expression in stained, leaded, etched or beveled glass, or choose to restore, repair or protect your glass, Valerie's 22 years of experience assures you of the highest standard of quality expected of Pike Stained Glass Studios, Inc.

180 St. Paul Street  
Rochester, NY 14604  
716 546 7570

Circle No. 460



Since 1908

**Pike  
Stained  
Glass  
Studios,  
Inc.**

## "GREAT PANES" Stained Glass

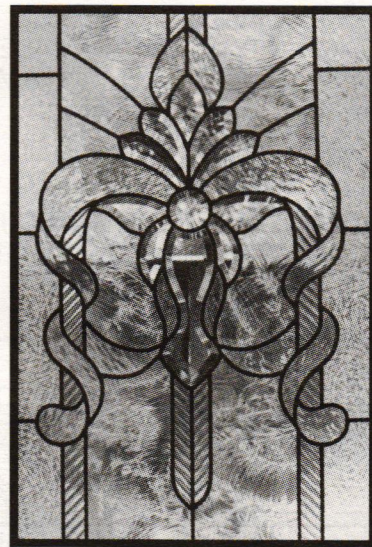

Churches • Commercial  
Residential • Restoration

8069 Main St.  
Historic Ellicott City  
Maryland 21043  
(301) 461-9336

Circle No. 456



BLENKO  
HANDMADE

MADE IN THE U.S.A.

hand blown window glass made in the "old timey" wood mold method. maximum size sheets 18" x 23" untrimmed panes, cut-to-size quotation upon request

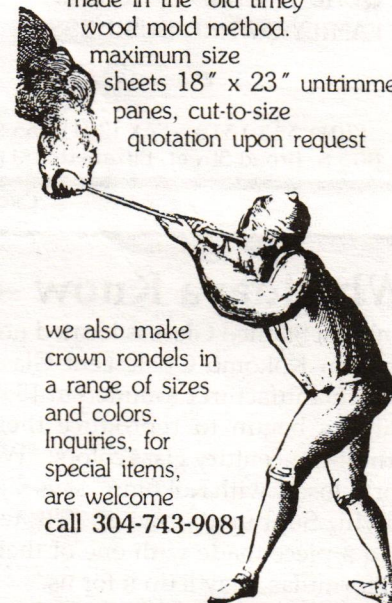

we also make crown rondels in a range of sizes and colors. Inquiries, for special items, are welcome call 304-743-9081

**THE BLENKO GLASS CO., INC.**  
MILTON, WEST VIRGINIA 25541

Circle No. 219

## Art-Glass Innovators

Harold W. Cummings founded Cummings Studios in 1922, and he soon pioneered lucent mosaics: He



poured hot lead over a field of glass chips. Now run by his son and granddaughter, the firm pursues restoration work as well as new techniques. "We've looked into restoring the lucent mosaics," says Christie Cummings Shelburne. "They're going to be tough; they're a horse of a different color."

Cummings Studios specializes in large projects for commercial, civic, and ecclesiastical buildings around the country. They work with a number of well-known designers, including David Wilson, Albinas Elskus, and Hilda Sachs (shown is the traditional-looking vine-patterned windows Ms. Sachs designed for H. H. Richardson's Senate Chambers in Albany, N.Y.). Currently Cummings is repairing dozens of stained-glass panels at Harvard University's Memorial Hall, where the literary figures and gods that gaze down on test-taking students have been unrecognizably dirty for decades.

For more information on Cummings Studios, see the pullout SourceList in this section. —EMK

## THE LONGEST COMMISSION



Since its founding in 1898, Willet Studios has amassed a library of 2,000 books, 200,000 slides, and countless drawings. "We use them to research different religions and subjects — from flowers to astronauts," says Gussie Willet, the founder's granddaughter-in-law and wife of the president, E. Crosby Willet.

The company's work is mainly institutional and commercial — "Our overhead doesn't allow us to do little door lites," Mrs. Willet says — and appears in all 50 states and in 14 countries. Some of Willet's craftspeople have worked for the company for decades, and among their achievements are the windows at West Point's Cadet Chapel (shown). Two windows were installed annually from 1910 to 1976, the longest continuous commission in the history of American stained glass.

Willet concentrates on new work while Hauser Studios, which purchased Willet in 1977, undertakes large restorations. (Hauser Studios of Stained Glass, 177 Lafayette St., Winona, MI 55987 (800) 533-3960.)

For more on Willet Studios, see the SourceList in this section. —EMK

## HORTON BRASSES

Manufacturers of Cabinet  
and Furniture Hardware for  
Homes & Antiques for  
Over 50 Years.

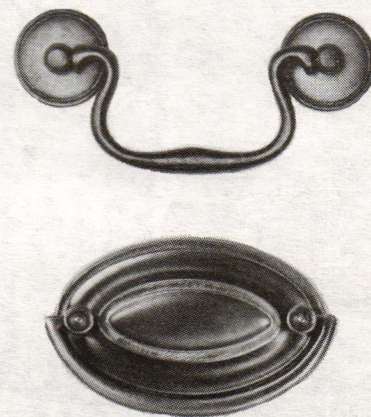

HORTON BRASSES are authentic copies of 17th, 18th, 19th and early 20th century pulls.

Nooks Hill Road, P.O. Box 120T  
Cromwell, CT 06416 (203) 635-4400

Send \$3.00 for a Catalogue

**PORCELLI STUDIO**

64 WOODSTOCK DRIVE  
 NEWTOWN, PA 18940  
 (215) 860-9947

SPECIALIZING IN MUSEUM  
 QUALITY AMERICAN MADE  
 REPRODUCTION TIFFANY LAMPS  
 AND BRONZES

REPRODUCTION & PERIOD  
 WINDOW COMMISSIONS

SERVING COLLECTORS AND THE  
 TRADE WITH NINETEEN YEARS OF  
 LAMPMAKING EXPERTISE

REPAIR & RESTORATION  
 SERVICES AVAILABLE

SAMPLE GLASS PAK: \$15.00

CALL OR WRITE FOR CURRENT  
 LISTING & PRICE LIST



Circle No. 497

**JERSEY ART  
 STAINED GLASS STUDIO**

DESIGNERS & MANUFACTURERS  
 OF CUSTOM LEADED, BEVELED  
 & STAINED GLASS WINDOWS

RESTORATION • CONSERVATION

ETCHED & CARVED GLASS  
 LEADED GLASS LAMPS

COMMERCIAL • RESIDENTIAL  
 • ECCLESIASTICAL

QUALITY CRAFTSMANSHIP  
 FAMILY-OWNED BUSINESS

EST. 1947

(201) 353-1318 FAX (201) 355-9389  
 603 S. Broad Street, Elizabeth, NJ 07202

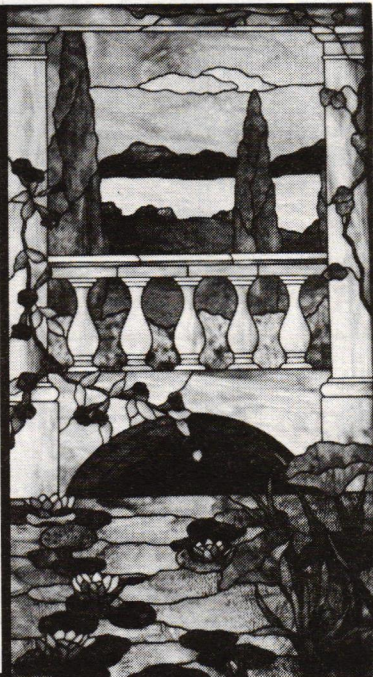

Circle No. 457

**FIELD WORK**

At any given moment, Shenandoah Studios is maintaining a half-dozen restoration crews in the field and has 60 new-window projects in house. They work nationwide, in traditional and contemporary styles.

The studio is well known for its large glass collection, often salvaged from windows that are beyond

repair. When Shenandoah recently restored a stained-glass skylight at the Library of Congress, the Capitol's assistant architect, William Ensign, commented, "It took great skill to match the colors. The repair work isn't noticeable."

For more on Shenandoah Studios, see the SourceList in this section. —EMK



**Whaddaya Know — Glass from Kokomo**

Sunburst Stained Glass is located not far from Kokomo Opalescent Glass Co., a manufacturer founded in 1888 that has begun to reproduce their turn-of-the-century glass colors. "We work closely with Kokomo," says Sue Colvin, Sunburst's owner. "If we need a piece made with one of their old formulas, they'll do it for us."

Sunburst houses three divisions: Kitchen cabinet door inserts; new work (about one third

commercial and residential, the rest ecclesiastical); and restoration (mainly ecclesiastical). For cabinet doors, "we can match paint or wallpaper samples," Colvin says. Their restoration work ranges from single windows — the c.1910 piece shown was "in pretty sad shape" until Sunburst rebuilt it for a local hospital — to whole buildings.

For more about Sunburst Stained Glass, see the SourceList. —EMK



*Covering the Bases*



Architects Ralls Melotte and Richard Morse have divided Melotte-Morse into three divisions: architecture, asbestos abatement, and stained glass. Architecture and glass occasionally overlap, for example when the firm designs a church, but usually the stained-glass section is involved in its own large-scale projects.

Two recent assignments involved repairing 287 zinc-camed windows for Frank Lloyd Wright's Dana-Thomas house in Springfield,

Ill., and rebuilding the colorful 19th-century dome (shown) at the Illinois State Capitol. To reach the 9,000-piece, 26-ft.-dia. dome, Melotte-Morse built a platform 118 ft. above the rotunda floor. From the platform, workers still had to climb a 315-step spiral stair to reach the stained-glass panels in order to lower them for shop repairs.

For more information on Melotte-Morse Stained Glass, see the pullout SourceList. —EMK

## Subliminal Stained Glass



Larry Casola spots stained glass everywhere. "You can't turn on the TV anymore without seeing it," he says. "It's in the background in all the ads, the soap operas, even 'The Cosby Show.'" These subliminal suggestions, he adds, are influencing the booming Florida construction business that Casola Stained Glass services.

"We've been building windows for model homes and private

homes," he says. "Textured glass is very popular, because it doesn't overpower the room; we've got 30 varieties on hand." He also works on commercial and ecclesiastical structures, in any style. The Victorian units (shown) appear in a Brooklyn, N.Y., house.

*For more information on Casola Stained Glass, see the pullout SourceList in this section. —EMK*

## Something Different

Great Panes just finished their 1,000th custom window. The 10-year-old company works mainly in the Baltimore/Washington area; the peacocks shown hang in an Owings Mills, Md., home. The studio almost never duplicates any pieces it has previously produced. "People want to make their house stand out," says owner Len Berkowitz. "They ask for something unique."

Among the company's ecclesiastical projects is a 6-by-16-ft. traditional religious scene for a local Korean Presbyterian church. For a 19th-century church the studio restored six 3-by-15-ft. windows, and for a Baltimore elementary school, they're currently creating a very contemporary 20-by-18-ft. fused glass mural.

*For more on Great Panes, see the pullout SourceList. —EMK*

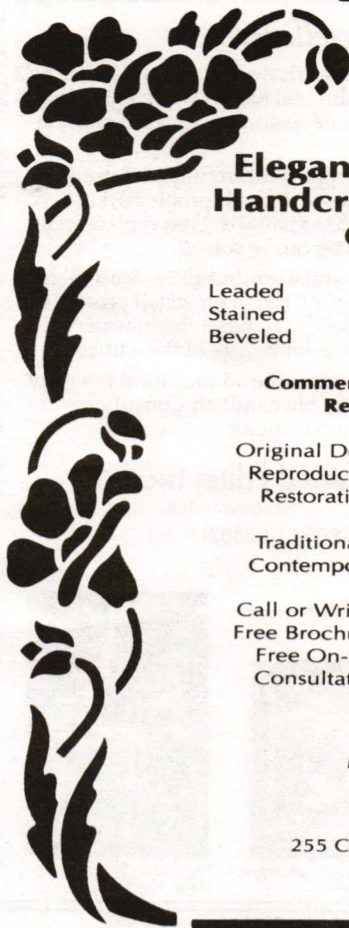
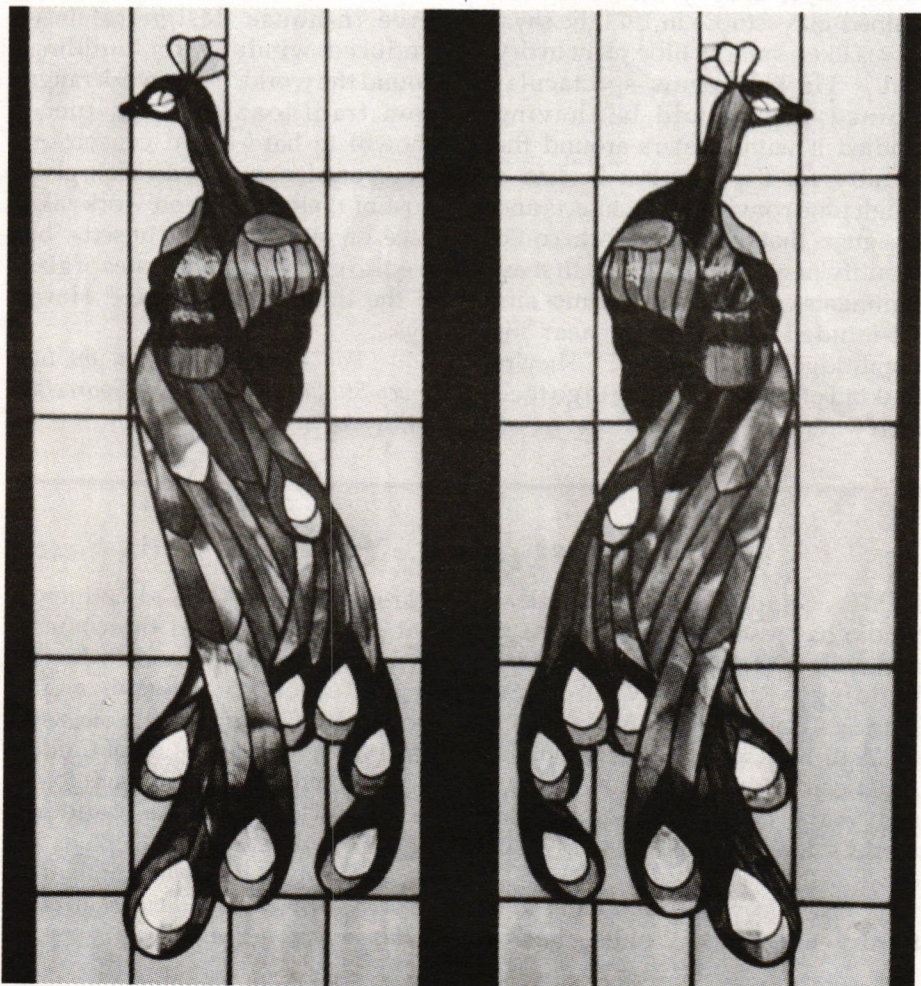

### The Elegance of Handcrafted Glass

Leaded Stained Beveled      Etched Carved

**Commercial and Residential**

Original Designs Reproductions Restorations

Traditional to Contemporary

Call or Write for Free Brochure or Free On-Site Consultation

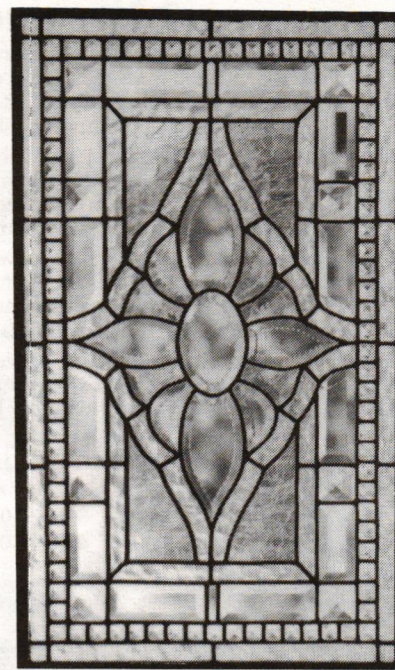

**Marchese & Hamersma**

Stained Glass Studios  
Established Since 1933

255 Crooks Avenue, Clifton, New Jersey 07011  
**201-340-7575**

Circle No. 458

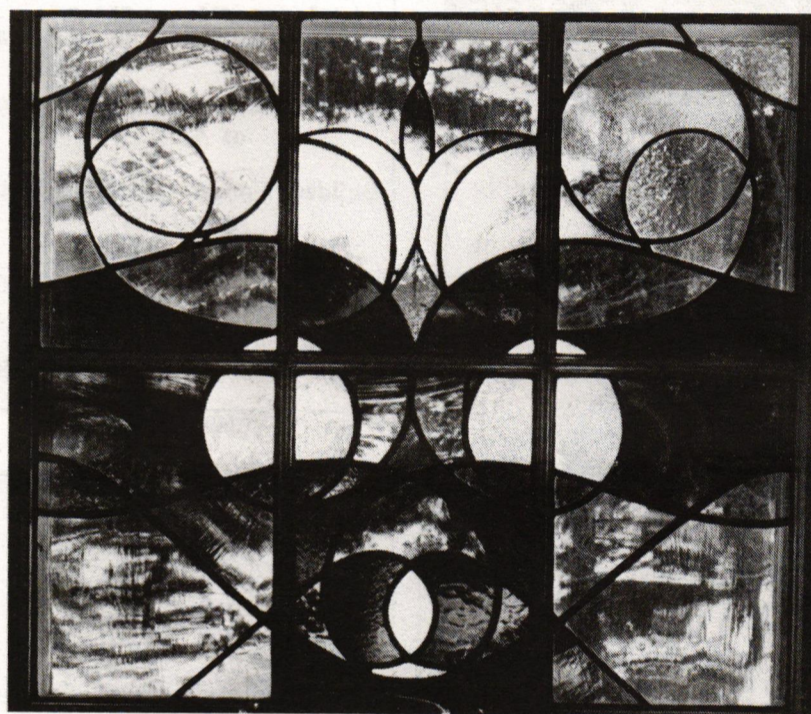

Beyer Stained Glass creates windows that speak fluently in Georgian, Federal, Victorian or contemporary designs. Restoration becomes fine craftsmanship under our attention. Contact Joe Beyer for a consultation about your traditional building project.

**BEYER STAINED GLASS**

6915 Greene St., Philadelphia, PA 19119 215/848-3502

Circle No. 451

## CUMMINGS STUDIOS

NEW CONSTRUCTION  
DESIGN &  
RESTORATION

ARCHITECTURAL  
GLASS

EXCEPTIONAL  
CUSTOM WORK  
LARGE & SMALL SCALE  
SINCE 1922

(413) 664-6578 • MA  
(619) 583-2932 • CA

BOX 427  
NORTH ADAMS • MA 01247

Circle No. 454

## LIGHTING ART



EXQUISITE HANDCRAFTED  
LIGHTING FIXTURES OF WOOD  
AND LEADED STAINED GLASS.

Ask for a free brochure, or send \$4.00 for our 12 page design portfolio of wall lanterns and chandeliers.

Architectural Rarities, Ltd.  
10650 County Road 81  
Maple Grove, MN 55369  
612-424-1158 • 800-328-9493

Circle No. 489

*A Commitment To Excellence*

**Design/Fabrication:** Shenandoah Artisans design and fabricate intricate and inspiring leaded or faceted glass masterpieces using traditional methods in combination with today's technology. Our Master Artists create custom designs in Traditional, European and Contemporary styles.

**Restoration:** Complete restoration of valuable stained glass is carefully performed by the Shenandoah Master Craftsmen. Even the most difficult problems, such as: deterioration, bulging, fire damage, pictorial handpainted glass replacement, decaying cement, and weather damaged framing can be solved.

**Protection/Insulation:** Concerns about weathering, vandalism, burglary, or accidents are a worry of the past when Shenandoah Master Craftsmen install protective coverings. Stained glass can be insulated for energy savings, remain watertight and weather resistant, and still maintain the exterior beauty of the edifice.

**Aesthetics:** Careful consideration is given to maintaining the architectural integrity of both the interior and exterior of the building. Shenandoah Consultants are available nationwide for window by window evaluations.



**Shenandoah Studios of Stained Glass Inc.**

908 John Marshall Highway Front Royal, Virginia 22630-1468

1-800-368-3079 (in Virginia, 1-800-523-8882)

703-636-2937

Offering a full range of stained glass window services: original design, restoration, protection and insulation of fine art windows.



Restoration in Meridian, Mississippi

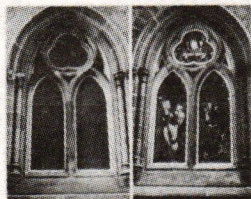

Before / After: First Presbyterian Church, Philadelphia, Pennsylvania

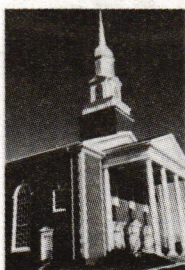

The First Baptist Church, Galax, Virginia

Circle No. 463

**THE CUTTING EDGE**



When Lyn Hovey founded his stained-glass studio in 1971, he says, "I was like a spindly little plant in dry soil." He knew how spectacular stained glass could be, having studied it with masters around the country for 8 years, but he had a tough time convincing architects and designers that this old art form could beautify new buildings. His first assignments came from academic- and art-minded homeowners near his Cambridge, Mass., studio. "They're the kind of people who like to go their own way," Hovey says.

He and his staff (including three in-house designers) have produced windows for buildings around the world. Their work ranges from traditional painted pieces (shown) to hard-edged concoctions of mirrors, lenses, and dichroic glass. Most of their restoration work takes place on site in Massachusetts, but "we also get mysterious crates of glass all the time, from all over," Hovey says.

For more information on Lyn Hovey Studio, see the pullout SourceList in this section. —EMK

*Landmark Glass*

Rohlf's Stained & Leaded Glass Studio has restored stained glass at five of New York City's most familiar buildings: Riverside Church, St. Patrick's Cathedral, Trinity Church on Wall St., Carnegie Hall, and the American Airlines terminal at Kennedy Airport, which once housed the world's longest stained-glass window.

year-old firm has worked on important structures around the country. Their English branch handles domestic and export commissions and is headed by Frederick W. Cole, who supervised the restoration of Canterbury Cathedral's stained glass for 12 years (and designed the traditional piece shown on the left).

Now run by the second and third generation of Rohlf's, the 70-

For more on Rohlf's Stained & Leaded Glass, see the pullout SourceList in this section. —EMK

**Golden Age Glassworks**

- Quick turnaround on custom jobs
- Custom designs in any style
- Traditional and naturalistic motifs a specialty
- Restorations and reproductions
- Expansions & alterations of existing panels
- Museum-quality work
- Antique stained glass available (American, Canadian, English)
- Experienced in working with architects & designers

See also our *Magnolia Window* in the section on Art Glass



Barbara Arrindell, Prop.  
*Golden Age Glassworks*

339 Bellvale Road  
Warwick, N.Y. 10990  
(914) 986-1487

Circle No. 28



**Fine Victorian mirrors and cabinets**

Featuring scrolled wood designs with stained glass and beveled mirrors.  
P.O. Box 612  
Goodland, KS 67735  
(913) 899-2297  
Catalogue — \$2.00

*Ravenglass Pty. Ltd.*

Circle No. 498

*Artisan Glass Works, Inc.*

Member: Stained Glass Association of America

Builders' Congress 'Craftsmanship' Award 1987

5700 Bellona Avenue  
Baltimore, MD 21212  
(301) 435-0300 FAX 435-0344

Circle No. 450



Quality Stained Glass

Specializing In

**ALL FACETS OF STAINED & LEADED GLASS**  
ORIGINAL DESIGNS & RESTORATIONS  
COMMERCIAL • RESIDENTIAL • CHURCHES

**(914) 34-GLASS**

3 SOUTH ST., MIDDLETOWN, NY 10940  
We work all over the NY Metro area, including NJ.

Circle No. 455





## MORE THAN PROTECTION



Partners since 1983, Tage Jakobsen and William Miles of Artisan Glass Works have watched their customers evolve. "There's much more understanding of restoration standards and technology today," says Miles. "People understand why we won't cover up problems with protective glazing."

While Artisan also tackles new projects in contemporary and traditional styles, their restorations tend to

be their most demanding assignments. They recently rebuilt 16 c.1914 opalescent windows for a fire-gutted chapel at Andrews Air Force Base, near Washington, D.C. Shown are Mr. Miles and workman George Kearson re-installing one of five c.1905 skylights at the Maryland State House.

For more on Artisan Glass Works, see the SourceList. —EMK

## The Big Time

Conrad Schmitt Studios, located in New Berlin, Wisc., executes all sizes of stained-glass commissions, but their present projects tend to be substantial. The studio maintains over 900 glass colors and textures in its inventory, some of which were recently used to repair the Tiffany

operates as a full-service decorative arts workshop.

Also in progress is 720 sq.ft. of new stained glass for the All Faiths Chapel at Father Flanagan's Boys-town in Omaha, Nebraska. Each piece will be painted, and the finished building will resemble a 13th-century

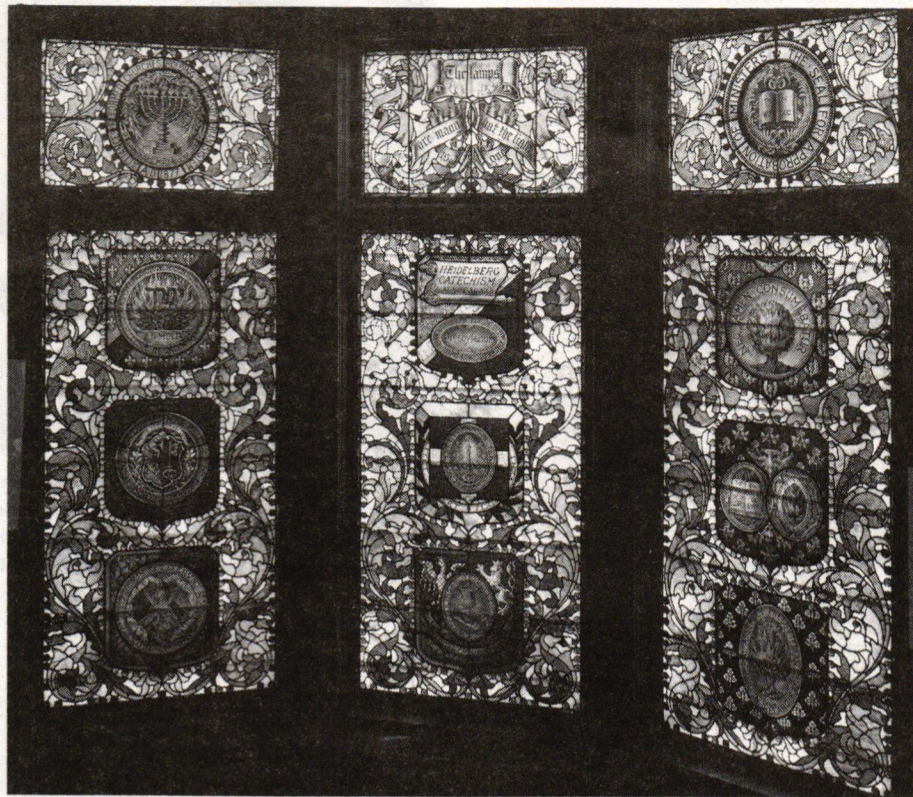

windows at the King Ranch in Kingsville, Texas. The studio is now involved in a 3-year restoration of the University of Notre Dame's Sacred Heart Church, which will include the windows as well as the interior. The company was founded and still

cathedral. Shown is a triptych from Milwaukee's Immanuel Presbyterian Church, which required a year to research and repair.

For more information on Conrad Schmitt Studios, see the pullout SourceList in this section. —EMK

### Division 7, continued from page 6

#### HISTORIC OAK SHAKES AND SHINGLES

### Oak Crest MFG. INC.

#### Lifetime Oak Roofing

Known to Last 80 or more years.

- Authentic Hand Split Oak Shakes as used by settlers centuries ago — ideal for authentic restorations.
- Beautiful Split Sawn Oak Shingles — Split textured surface for a rustic look with the uniformity of a shingle.
- Smooth Sawn Oak Shingles — a neatly sawn shingle ideal for conventional roofing and siding.

A Unique Wood Product



FOR MORE INFORMATION WRITE OR CALL: OAK CREST MFG., P.O. BOX 128, JONESBOROUGH, TN 37659-0128; 1-615-753-6599 1-800-678-3145

Circle No. 365

## YOUR NUMBER IS UP!

Take a close look at your mailing label . . .

If the top line reads: 02/01/99, you're receiving a TRIAL subscription to TRADITIONAL BUILDING. That means your name will soon be eliminated from our circulation list. To make sure you get EVERY ISSUE of TRADITIONAL BUILDING, fill out the coupon below and mail it in with your check for \$18 for a 1-year subscription.

NAME \_\_\_\_\_

COMPANY \_\_\_\_\_

ADDRESS \_\_\_\_\_

CITY \_\_\_\_\_

STATE \_\_\_\_\_ ZIP \_\_\_\_\_

PHONE ( ) \_\_\_\_\_

Your Business:  Architect  Contractor  Interior Designer  Engineer/Consultant  Government  Other

Mail to: Traditional Building, 69A Seventh Ave., Brooklyn, NY 11217

### Quartersawn Clapboard

AUTHENTICALLY PRODUCED COLONIAL CLAPBOARDS • RADIALLY SAWN • SQUARED EDGE



Our specialty: Custom sawing any size, width, and tree species for your restoration.



Spay Lodge Farm

46 Wendell Road, Shutesbury, MA 01072  
1-413-259-1271

Circle No. 437

■ To get free product information: Use the enclosed postpaid card, or fill out the coupon on page 38.

Maine's Only Producer of Traditional "Quartersawn" Pine Clapboards

### DONNELL'S CLAPBOARD MILL

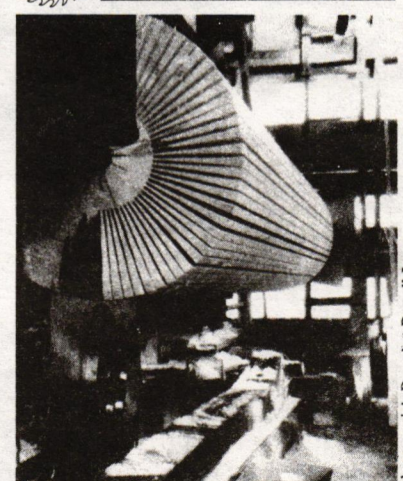

With special 19th century machinery we have revived an almost forgotten sawing process. We produce the authentic air-dried radially sawn clapboards for the exacting customer or the discriminating builder. For informative brochure please send \$1.

Donnell & Donnell  
Country Road, R.R. Box 1560  
Sedgwick, Maine 04676  
(207)-359-2036

Circle No. 26

## Profile: HOLMES

*continued from page 5*

manner of antebellum structures with sketch pad and folding rule," recalls Nicholas Two.

Continuing the tradition, in 1975 Nicholas Three spent the summer months in Talequah, Okla., doing the same things in the governmental buildings of the Cherokee Nation that his grandfather had done 40 years before.

Because of this close family association with HABS, Nicholas Two established a new company policy: When the firm makes measured drawings of an historic structure, the drawings are usually made according to HABS standards. This allows the owners of the property to donate the drawings to the HABS collection in the Library of Congress.

Nicholas Two and Three also maintain close connections with their alma mater — the architecture school at Auburn. One recent project was to promote interest in measured drawings of historic buildings among Auburn students. Working with Robert Kapsch, head of HABS, Larry Oaks, Exec. Dir. of the Alabama Historical Commission, and Robert Gamble, Architectural Historian with the Commission, Nicholas Holmes, Jr. helped interest the Architecture Dept. in setting up a course on measured drawings done to HABS standards. The course has proved tremendously popular and has resulted in several Peterson prizes for Auburn students. (The Peterson Prize is awarded annually by the AIA's Committee on Historic Resources for the best student work in delineating HABS drawings.) In 1989, nine students from Auburn worked on HABS summer teams — more than any other architecture school.

And through Nicholas Three's efforts, the Alabama AIA now awards the annual Burkhardt Prize for the best HABS drawing produced by an Auburn or Tuskegee student.

## Architecture In The Gene Pool

In the case of both Nicholas Two and Nicholas Three, it was far from a foregone conclusion that they would go

*continued on next page*



The Alabama State Capitol in Montgomery was rebuilt in 1851 by architect Barachias Holt after an 1849 fire destroyed the original building. The East Wing was added to the rear of the building in 1885. South and North Wings were added in 1907 and 1912 after the Lockwood plan was declared the winner of a design competition. Charles McKim of McKim, Mead, and White was then consulted and had great influence in the final design of the wings.



The firm of N.H. Holmes, Architect, designed an expansion of the Capitol's East front, which is now under construction. The Holmes' neoclassical design includes a colonnaded porch that extends the front 50 ft., as well as 1-story additions to each side of the porch that house an auditorium, gift shop, and mechanicals. The stucco-on-brick construction echoes the original building.



Mobile City Hall, built in 1857, was devastated by Hurricane Frederic. The Holmes firm did three complete sets of drawings for its repair: (1) Drawings for temporary repairs; (2) A full set of drawings for the insurance adjusters; and finally (3) A set of drawings for the restoration that, among other things, removed many decades of accretions.

continued from previous page

into the architecture business. In fact, both initially resisted the idea. The fact that they both ended up as architects suggests that there must be an architect gene somewhere in the Holmes DNA.

Nicholas Two originally set out to study chemistry. "I had watched my father struggle during the Depression," he recalls, "and concluded that architecture was a very risky profession." But World War II interrupted his chemistry studies. Serving in the Army from 1943 to 1946 changed his perspective on careers; he decided he wanted to be in business for himself — and architecture didn't look so bad after all. After graduating with an architecture degree from Auburn, Nicholas Two

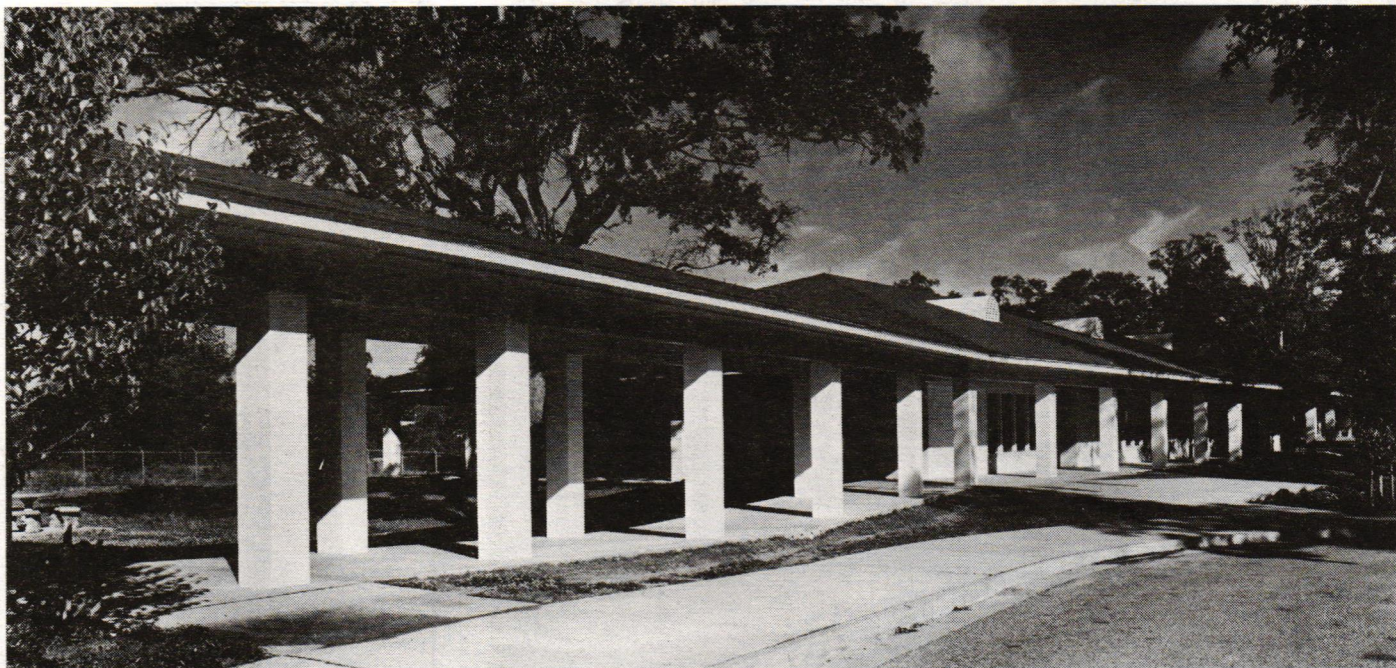

The Holmes' elementary school classroom building for the U.M.S./Wright school uses an arcaded walkway for exterior circulation, recalling antebellum southern homes.



A Tax-Act rehabilitation in downtown Mobile converted an old Grant's department store to offices. Aluminum and enamel storefronts had to be removed from the facade; the Holmeses designed a new front similar to the original.



Division 8  
DOORS & WINDOWS

Under the Dome

The 100-year-old New Jersey State House, an eclectic Victorian building capped by a gold dome, contains 170 doors, each one unique. Camden Window & Millwork is restoring those doors (see photo). "The building was empty for a few years, and before that it went through a lot of wear and tear," says president Michael Mullock. "Some of the doors have to be replaced, some have been badly repaired over the years, some have delaminated." The company is also working on the state house in

Providence, R.I., another gold-domed building: "That seems to be our specialty this year," Mullock says.

They prefer to work in mahogany for exterior doors, and for interior doors the wood is "the customer's choice," Mullock says, and he adds, "If it's ever been made in wood we can re-make it."

For more information, contact: Camden Window & Millwork, 1551 John Tipton Blvd., Dept. TB, Pennsauken, NJ 08110 (609) 662-4646. CSI# 08200 — EMK



worked for three other firms before entering partnership with his father in 1954. (Nicholas, Sr., passed away in 1957).

Nicholas Three went through a similar odyssey. He originally graduated from Auburn with a B.S. in Forestry. "But after working in forestry for a while I realized that if I didn't own the forest I would always be working for someone else." So he went back to Auburn and in 1978 emerged with a B.S. in Environmental Design along with a Bachelor of Architecture. Late in the same year he joined his father's firm.

When asked if all this family togetherness doesn't get claustropho-

bic at times, both father and son demur. Nicholas Two points out: "We each have our own set of clients, and serve in mutually supportive roles on each other's projects." Nicholas Three adds: "We focus on solving functional problems — the real problems of architecture, and have respect for each other's opinions."

However they worked out the inner dynamics of a family business, they clearly have hit on a winning formula. There's only one major question in the firm's future: Have either of Nicholas Three's two daughters, Kate (8) and Clara (6), inherited the Holmes architecture gene? ♦

**SPRINGFIELD**  
Solid  
Brass  
Handleset  
**\$200**  
Same Day Shipment

**BALDWIN**

Extensive Inventory.  
Same Day Shipment.

Call Our Team of  
Professionals Today.

**LEXINGTON**  
24"  
Towel Bar  
**\$70**  
Same Day Shipment

**LEXINGTON**  
Solid  
Brass  
Handleset  
**\$180**  
Same Day Shipment

**JE  
SMITH**  
ARCHITECTURAL HARDWARE  
Service You Can Build With

**1-800-345-5625**  
FAX: (203) 757-0234

Waterbury, CT 06721  
Since 1897



CONTACT US FOR ALL  
YOUR BUILDER'S  
HARDWARE NEEDS!

Circle No. 136



## Creative Openings





Custom Made  
Hardwood  
Screen and  
Storm Doors

For complete catalog send \$4.00 to  
P.O. Box 4204, Bellingham, WA 98227  
(800) 677-6420 (206) 671-6420

Circle No. 383

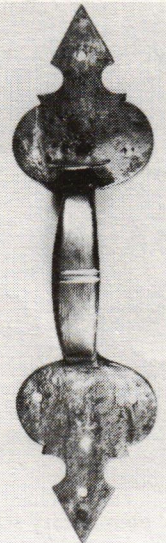
*Finely Wrought  
Reproduction  
Hardware*



**E.P. TITCOMB**  
17 Jan Sebastiaan Way  
Sandwich, MA 02563  
(508) 833-1168  
Send \$3 for catalogue

Circle No. 494

## AND WHEN ALL ELSE FAILS . . .

Window Components is the place to go if you have a part that just can't be found anywhere else. Although their products are targeted at the recreational vehicle industry, they also stock some hardware that's handy for metal window rehab projects. Window Components stocks 8,000 different parts, both obsolete and new.

**#307 METAL CRANK HANDLE**

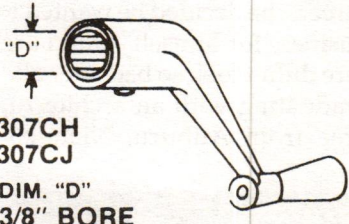

307CH  
307CJ  
DIM. "D"  
3/8" BORE  
5/16" BORE

A small but important part of the Window Components staff is the "Identifying Department." They staff two people whose job it is to do nothing all day but identify parts. When they receive a piece of sample hardware, they first classify it and then report whether a matching part or an acceptable substitution is in stock.

In addition to collecting window hardware from manufacturers who are no longer in business, Window Components also does its own stamping, fabricating, painting, and assembly. Prices for parts range from 20¢ to \$50.

For a list of distributors or a catalog, contact: **Window Components, 3443 NW 107th St., Dept. TB, Miami, FL 33167 (305) 688-2521. CSI# 08500 —JL**

## The 50 most beautiful Doorways in America.



Or anywhere! Our hand-carved doorways are the most beautiful available. In traditional Georgian and Federal styles from under \$2000 to \$8500. Carved overdoor motifs from \$350. Color brochure \$3.

**KENMORE INDUSTRIES**  
One Thompson Square, P.O. Box 34  
Boston, Massachusetts 02129  
(617) 242-1711

Circle No. 389

**CLASSIC ELEGANCE**  
*Chippendale*  
CUSTOM MADE MAHOGANY STORM-SCREEN DOORS



Beautifully handcrafted with specific attention to detail guarantees our wood storm doors to be the finest in the country. We also offer elegantly crafted doorware, benches, statuary, & more.

35 Authentic Styles

**TAYLOR BROTHERS**  
P.O. Box 11198, Dept. H  
Lynchburg, VA 24506

SEND \$2 FOR CATALOG OR CALL TOLL FREE  
1-800-288-6767

Circle No. 501

**REPLACE ROTTED SASH**



Any style, any size. Wood storms and screens, too. Costs less than you think. Fast turn-around. Insulated glass available. Call or write for facts.

**Midwest Wood Products**  
1051 South Rolf Street, Davenport, Iowa 52802  
(319) 323-4757

Circle No. 146

**WILLIAMSBURG BLACKSMITHS**

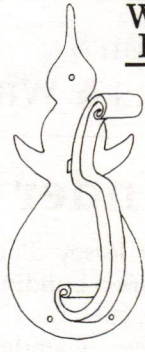

Quality Wrought-Iron Hardware

To Order Catalog, Send \$5 to:

P.O. Box 1776, Dept. TB  
Williamsburg, MA 01096  
Phone: (413) 268-7341



**HOPE'S STEEL WINDOW HARDWARE**

Scroll handles, casement operators and numerous other solid bronze, heavy-duty items in the original fine old designs.

Direct from "Hope's" the first steel window maker in the U.S.A., established in 1912.

We carry a large stock. Also many old patterns are available for special orders. Call or write. Send samples if possible.

**HOPE'S LANDMARK PRODUCTS INC.**  
P.O. Box 580  
84 Hopkins Ave., Jamestown, NY 14702-0580  
Phone (716) 665-6223 FAX (716) 665-3365

Circle No. 312

**Historically Accurate DOOR HARDWARE**

The nation's largest collection of authentic Early American and Victorian door hardware:

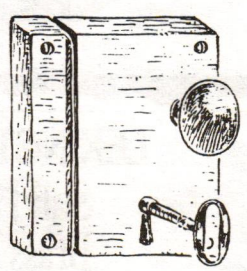

- Brass & Iron Hinges
- Latches
- Box Locks
- Knobs & Locks

And much more. See our ad on page 40 for complete details. Send for free catalog.

**Ball & Ball**  
463 W. Lincoln Highway  
Exton, PA 19341  
Tel. (215) 363-7330  
FAX (215) 363-7639

Circle No. 293

## Interpretive Early American

Amid the mantels, molding, paneling, doors and bookcases in Colonial Woodworks' catalog, you'll find four types of windows: Palladian, double-hung, half-round, and round. The designs, according to CEO Carl Biathrow, are interpretations but not replicas of the fenestration found on old buildings. "The other day I saw my Palladian on a railroad station in a little Pennsylvania town," he says. "Goes to show you how art imitates life."

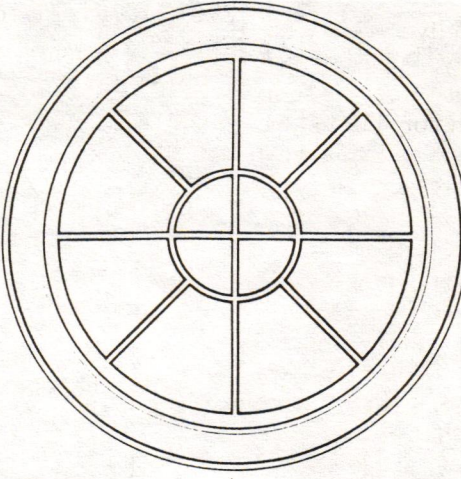

Four fluted pilasters surround the three windows on the Palladian, and the central arched unit is surmounted by a keystone. The half-round and round windows have 3-in.-thick sash. The double-hungs, Colonial's best-selling windows, come with two layers of 3/8-in.-thick glass and can have up to 18 lites; custom variations are also available.

For more information, contact: **Colonial Woodworks, Box 19965, Dept. TB, Raleigh, NC 27619 (919) 783-5592. CSI# 08600 — EMK**

**LOOKING FOR "INVISIBLE" STORM WINDOWS? HERE THEY ARE!**

**Historic  
Property Owners  
Renovation Contractors**

You will see the energy savings  
Not the Storm Windows

Match Any Color  
Match Any Shape  
Inside or Outside Mounted  
Inside or Outside Removable  
Screen and Glass  
Fixed-Magnetic-Sliding-Lift Out  
**Unlimited Possibilities**

**ALLIED WINDOW, INC.**  
2724 W. McMICKEN AVENUE, CINCINNATI, OHIO 45214  
(800) 445-5411 (TOLL-FREE)  
(513) 559-1883 (FAX)  
"Where custom work is standard"

Circle No. 69

## ONE-STOP HARDWARE SHOPPING

J.E. Smith is a Connecticut-based building supply center with a national clientele. Specializing in traditional builders' hardware, they carry the complete lines of Baldwin Hardware, Russwin (commercial locks), CCL (cabinet locks), Epic (faucets), Omnia Industries, HEWI, and Dexter.

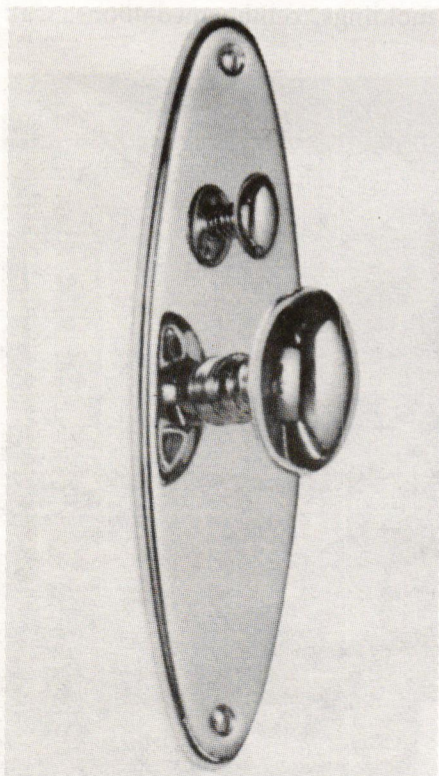

"Price and delivery are what make us unique," says Bob Marcotte, general sales manager. "People shop around locally, then come to us; we often ship the same day. We have a sophisticated clientele; they don't have to be sold on the merits of Baldwin Hardware."

One of J.E. Smith's hot sellers is Baldwin's "Springfield No. 6573," a solid forged and lacquered brass handle set. Shown is the inside escutcheon; \$200 buys it, the outside thumb latch, and lock.

Call or write: **J.E. Smith, 621 Bank St., Dept. TB, Waterbury, CT 06721 (800) 345-5625. CSI# 08700. — JL Or Circle No. 136**

## WOODSTONE... TEN YEARS OF WOODWORKING SERVICES

Not only does WOODSTONE manufacture only the finest custom solid wood windows, doors and architectural millwork...

IN VIRTUALLY ANY SIZE, SHAPE OR WOOD SPECIES...

### WOODSTONE OFFERS SERVICE!

TRADITION & TECHNOLOGY™ including:

- True made-to-order large & small project capacity.
- CAD CAM to match any other manufacturers' dimensions.
- A thin 1" overall muntin width available with insulating glass.
- Insulating glass available in virtually any shape.
- Glass from Beveled to Bull's Eye & Low-E to Leaded.
- Guaranteed pricing. Product Warranty.
- 24-HR FAX service & prompt detail description & job costing.
- On-the-road consultation & site visits... before & after the sale.
- Mortise & tenon joinery.
- An established landmark historical reproduction track record.
- Replacement packs for energy conservation & remodeling.

For an illustrated brochure, send \$3.00.



THE WOODSTONE COMPANY  
Box 223, Dept. TB, Westminster, Vermont 05158  
TEL: 802-722-9217 FAX: 802-722-9528

# WOODSTONE®

WOODEN WINDOWS & DOORS

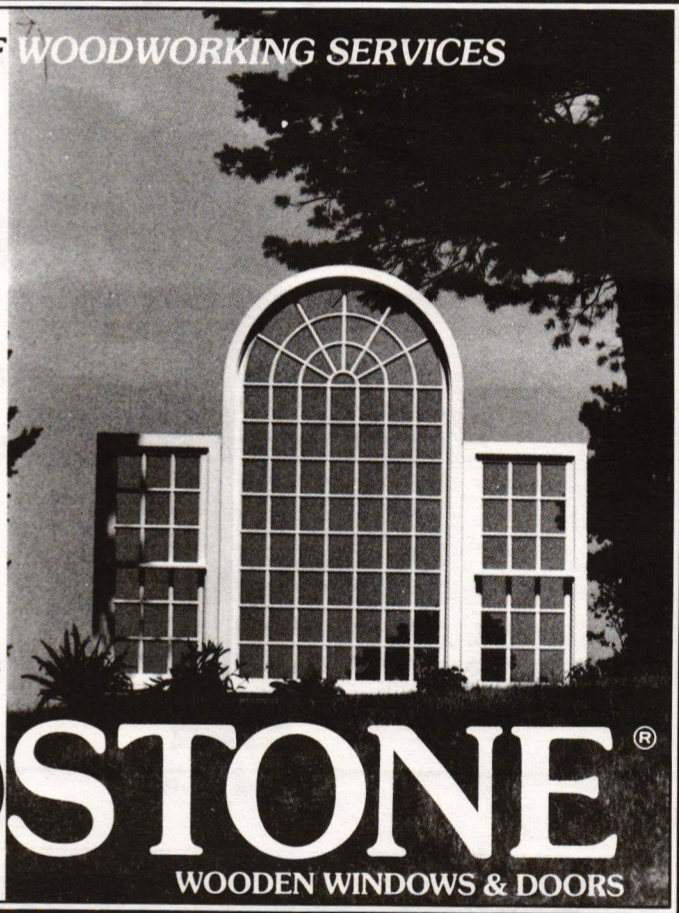

## TOP OF THE LINE

Tischler's doors are made of Swietenia mahogany, "the next best thing to teak for exterior use," says president Detlef Stroeh. The 102-year-old German company is known for its top-quality windows and doors. The doors come glazed or unglazed and feature Zeiss-Ikon five-bolt locks. Their sliding doors roll on ball bearings and they do not manufacture storm doors: "Those are only for doors that weren't well insulated to begin with," Stroeh says.

The company recently completed a steel-core wood door measuring 10 by 18 feet for a residence. "It cost as much as a little house used to cost," says Stroeh. "Architects are interesting people. And we'll build whatever they'll pay for."

Pictured is the entry for a Southport, CT renovation. The door and sidelights were built as a single unit by Tischler.

For more information contact: **Tischler und Sohn, Three Greenwich Office Park, 51 Weaver St, Dept. TB., Greenwich, CT 06830 (203) 622-8558. — CSI# 08200 — EMK Or Circle No. 516**



THE COMPOSITION GROUP, LTD.

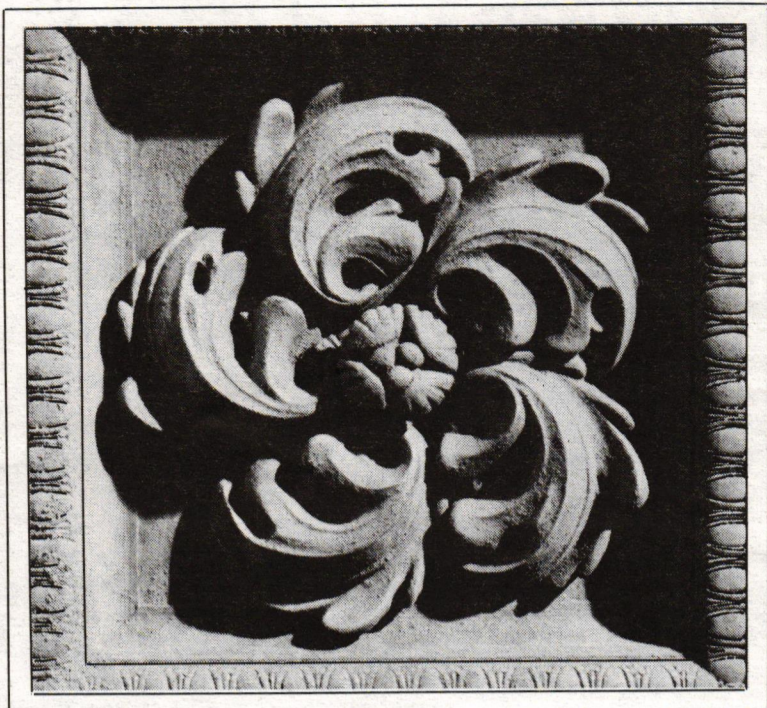

120-126 11th Avenue  
New York, New York 10011  
(212) 242-2288  
(212) 242-7043 FAX

FAUX FINISHES  
STENCILING  
MURAL PAINTING  
TROMPE L'OEIL PAINTING

Circle No. 507



### Cast plaster architectural elements

Cornices • Medallions  
Pilasters • Capitals  
Pedestals • Brackets  
Plaques • Moldings  
& Much More



ARCHITECTURAL  
SCULPTURE  
LTD.

242 LAFAYETTE STREET  
NEW YORK, NY 10012  
(212) 431-5873

Circle No. 245

### Kevin Rutan's FE FI FAUX, INC.

presents

### WORKSHOPS

in faux finishes

3-day instruction in marblizing • wood graining • wall glazing • fantasy finishes offering complete instruction in all aspects of faux finishes for both the novice and professional

For information

(919) 272-3289

8:30-2:30 EST

337 S. Davie Street • Greensboro, NC 27401

Circle No. 449

### The Color People

We provide professional exterior color schemes and designs to make your property exceptional. Our services are available nationwide by working through the mail. Call or write for our free mailer.

We also offer seminar programs for large or small groups such as Historic Districts and Mainstreet Projects.

1546 Williams St., #201  
Denver, CO 80218  
303/388-8686

Circle No. 481

Cartouches  
Friezes  
Centerpieces  
Brackets

Niches  
Cornice  
Grilles  
Mouldings

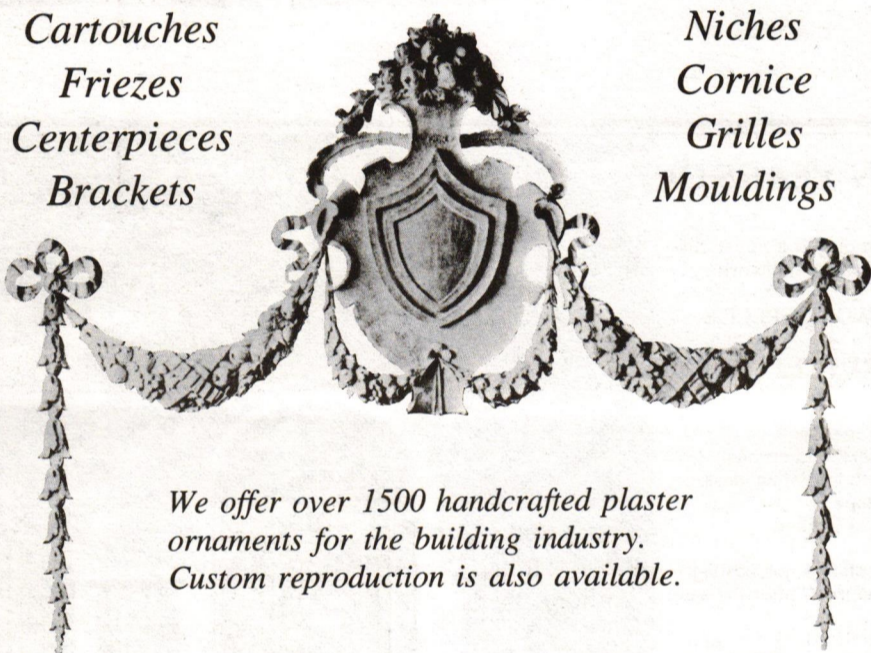

We offer over 1500 handcrafted plaster ornaments for the building industry. Custom reproduction is also available.

The Fischer & Jirouch Co.  
4821 Superior Ave., Dept. TB  
Cleveland, OH 44103



Bus. Tel. (216) 361-3840  
FAX Tel. (216) 361-0650

Circle No. 196



lights, niches, corbels, pilasters, and columns. High-density polyurethane is well known for its combination of sharp detail, deep relief, light weight, and ease of installation.

Columns, capitals, and plinths are sold separately (to mix and match) and are also available in halves for flush mounting. Ceiling medallions can be drilled for lighting fixtures. Moldings can be configured as chair rails, ceiling decorations, wainscoting, or to create wall panels. The pieces come primed, can be

painted or stained, and are installed like wood or with an adhesive, Orac-Fix.

Prices for the Orac Decor ceiling medallions (for example) range from \$22.05 (6 in. dia.) to \$130.75 (34 in. dia.), with discounts to professionals.

For more information about the Orac Decor line, contact: Cumberland Woodcraft, P.O. Drawer 609, Dept. TB, Carlisle, PA 17013 (800) 367-1884. CSI# 06200 — JL Or Circle No. 131

WOOD MANTLES  
CAPITALS  
BRACKETS  
MEDALLIONS  
PLASTER CORNICES  
WOOD MOULDINGS  
COMPOSITION & WOOD FIBER ORNAMENTS

Established 1893  
**DECORATORS SUPPLY CORPORATION**  
312/847-6300  
3610 S. MORGAN ST., DEPT. TB • CHICAGO, IL 60609

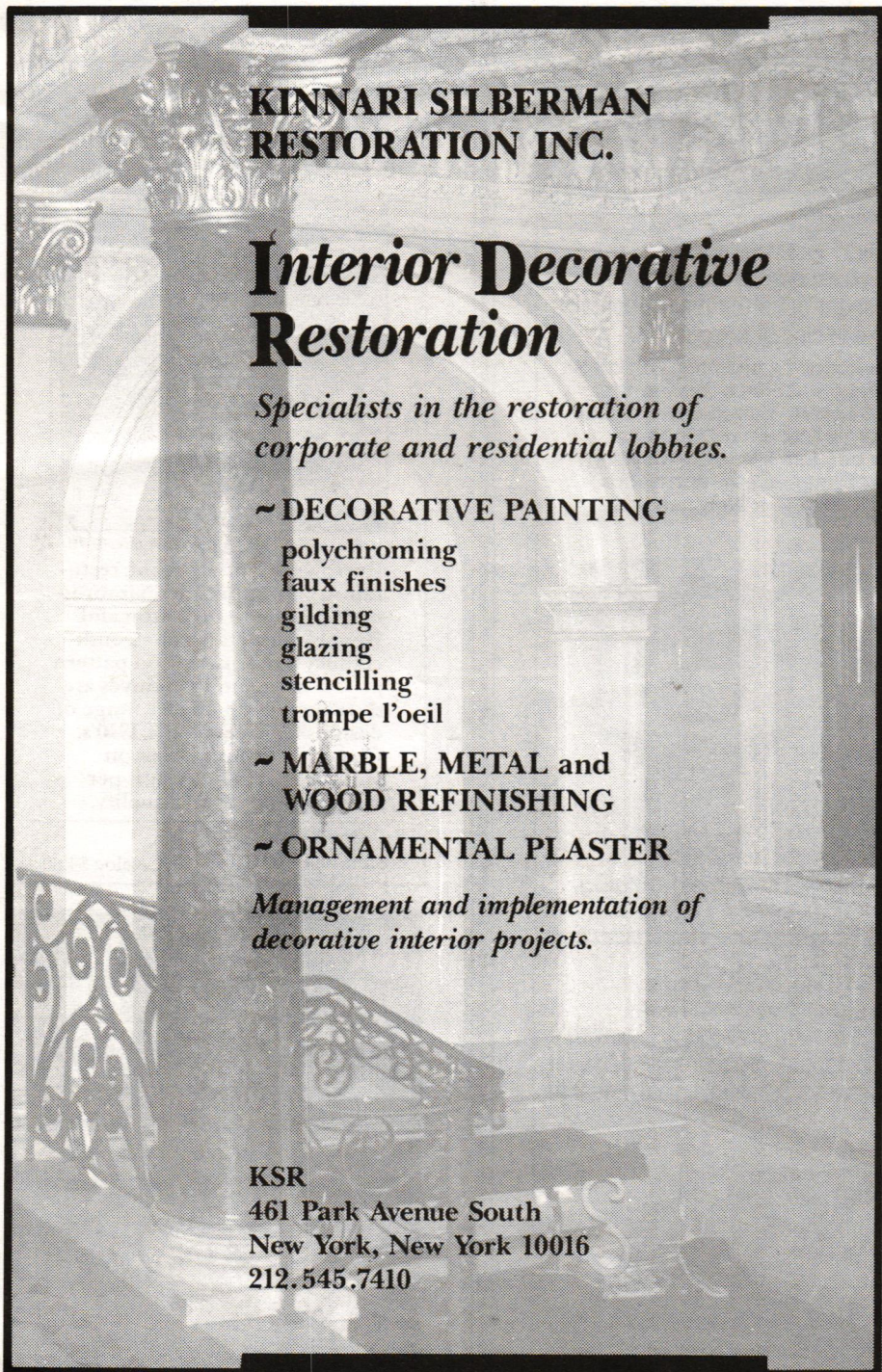

**KINNARI SILBERMAN RESTORATION INC.**

## Interior Decorative Restoration

*Specialists in the restoration of corporate and residential lobbies.*

- ~ DECORATIVE PAINTING
  - polychroming
  - faux finishes
  - gilding
  - glazing
  - stencilling
  - trompe l'oeil
- ~ MARBLE, METAL and WOOD REFINISHING
- ~ ORNAMENTAL PLASTER

*Management and implementation of decorative interior projects.*

**KSR**  
 461 Park Avenue South  
 New York, New York 10016  
 212.545.7410

Circle No. 301



Division 9  
FINISHES

SUSPENDED PLASTER CEILING TILES

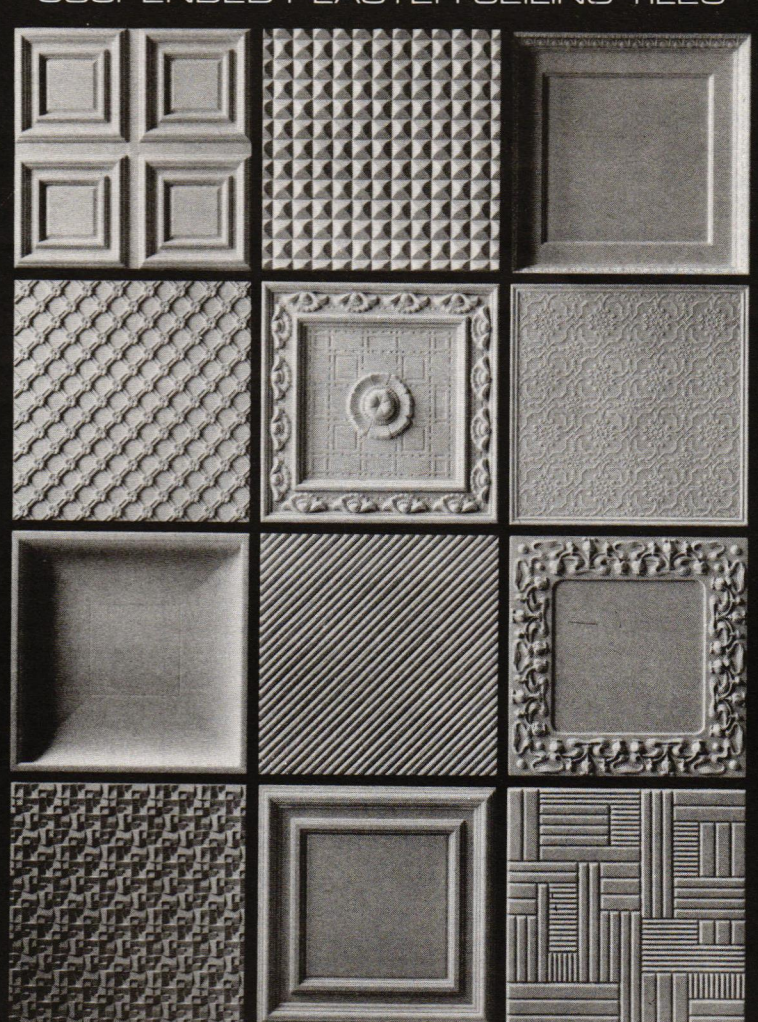

**ABOVE VIEW, INC.**  
 241 EAST ERIE STREET • MILWAUKEE, WI 53202 • 414-271-4477

Circle No. 376

## The Skies of Paris

The Twigs is perhaps less well known than other reproduction wallpaper manufacturers, but their work is no less noteworthy. They offer about 180 documentary papers, mostly English or American, and their colors are "either original or the kind that would have been used at that time," says president Arthur Athas.

Shown is part of their "Monuments of Paris" scenic, reproduced from an 1814 original for the Metropolitan Museum of Art. The sky is soft blue, the buildings are

arranged along the banks of the Seine, and the passersby are seen swimming, strolling, boating, or riding horses. The panels cover 48 ft. of wall. Each stands 9-1/2 ft. tall, and a set of 22 costs \$9,000. The "Embassy" edition, which reaches 15 ft., costs \$9,750.

Twigs' other papers are not quite so enormous, but they also tend to be dramatic. The line includes, for example, griffin- or caryatid-covered dadoes and various trompe-l'oeil borders depicting architectural ornament.

Contact: **The Twigs, 5700 Third St., Dept. TB, San Francisco, CA 94124 (415) 822-1626.** CSI# 09900 — EMK



## FIBERGLASS PILASTERS

On Aristocast's decorative archways, the arches are made of fibrous plaster while the pilasters are made of fiberglass. They use fiberglass-reinforced resin in high-traffic areas where plaster is more likely to chip.

There are two styles: Victorian, which has plain pilasters and a flat keystone, and Georgian, which has fluted pilasters and a curved, fluted keystone. The Georgian model is available in both custom and stock widths; prices range from \$1,175 to \$1,830 wholesale. The Victorian model comes in stock sizes only and costs between \$1,079 and \$1,578. Fibrous-plaster corbels can be substituted for pilasters, in which case the archway units cost slightly less. The \$3 color catalog shows the company's full line of moldings, medallions, and other ornament.

Contact: **Aristocast Originals Inc., 6200 Highlands Pkwy, SE, Suite 1, Dept. TB, Smyrna, GA 30082 (404) 333-9334.** CSI# 09200 — EMK Or Circle No. 118



**G. KOEPPHEL**  
 S T U D I O  
 6 1 7 • 5 2 2 • 3 0 5 1

Decorative Finishes  
for interiors and furniture

*Wood Graining  
Stenciling  
Gilding  
Marbleizing  
Glazing  
Trompe L'oeil  
Murals*

All inquiries welcome  
258 Chestnut Ave., Boston, MA. 02130

Circle No. 505

Coming In September

**Fireplaces  
Mantels  
Chimneys  
Hearth Tile**

The Nation's Most Complete Collection Of

# Architectural Sheet Metal

## Decorative Metal Ceiling & Wall Panels

Hi-Art™ Steel Ceiling systems are made using original 80-year-old dies. The Hi-Art™ line includes center plates, corner plates, border plates, cornice and filler plates — permitting classic designs proportioned for an exact fit. Over 140 patterns in either steel or copper.

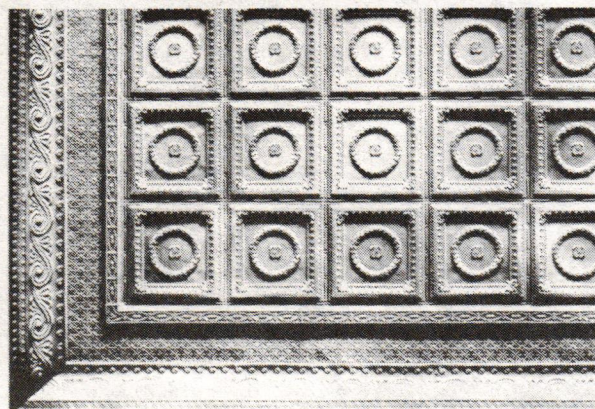
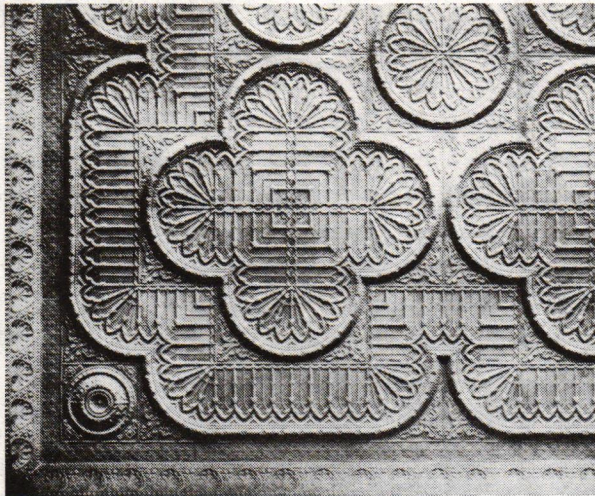

Write for 72-page Sheet Metal Ceiling Catalog.  
Or Circle No. 52

## Pressed Metal Siding

Pressed metal siding from turn-of-the-century dies: lightweight, durable, economical. Brick, Rock-Faced Brick, Pitch-Face Stone, and Cluster Shingle.

Write for Pressed Metal Siding brochure.  
Or Circle No. 52

## Sheet Metal Ornaments

Our 94-year-old line of sheet metal ornament contains over 1,300 items available in zinc or copper.

- ★ Cornices ★ Window Hoods ★ Moldings ★ Lintels
- ★ Capitals ★ Brackets ★ Corbels ★ Rosettes
- ★ Balusters ★ Urns ★ Capitals ★ Festoons ★ Finials
- ★ Scrolls ★ Leaves ★ Friezes ★ Canopies
- ★ Marquees ★ Glass pendant frames ★ Cresting
- ★ Garlands ★ Panel Ornaments ★ Lion Heads
- ★ Conductor heads & fittings ★ Weathervanes

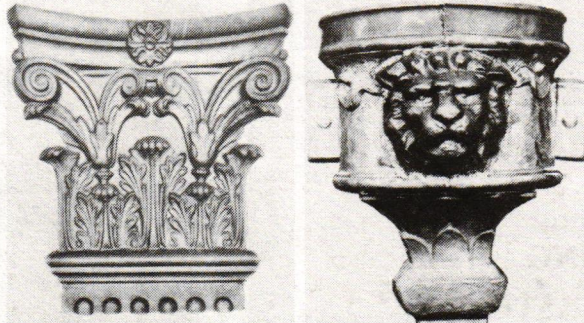

Send for 84-page Sheet Metal Ornament Catalog.  
Or Circle No. 52

## Metal Roofing Shingles

Original 1908 line of metal roofing shingles . . . available in galvanized steel or solid copper. Spanish Tile, Mission Tile, Victorian, and Slate styles. Cresting, finials, and trim also available.

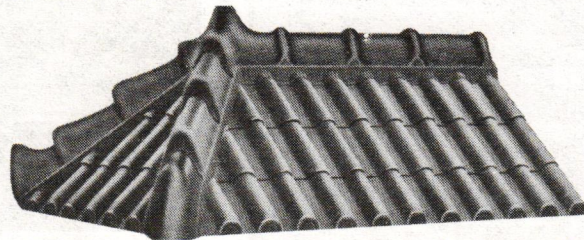

Write for Metal Shingles brochure. Or Circle No. 52

## Custom Reproductions

Our manufacturing process enables us to make reproductions of original panels on a custom basis . . . or to produce your original design. Call us to discuss your needs.

**W.F. Norman Corp.** P.O. Box 323 Nevada, MO 64772 800-641-4038

Circle No. 52

## VICTORIAN WALLPAPERS

- Handprinted Borders, Friezes, Ceiling Papers & Coordinated Wall Fills.
- Available Directly from our Studio by Mail Order.
- In-house Design Service.
- Color Catalog with Binder: \$10.00

**BRADBURY & BRADBURY**  
WALLPAPERS  
P.O. BOX 155-L • BENICIA, CA. 94510  
(707) 746-1900

Circle No. 13

“Proposition 1: ‘The decorative arts should arise from, and should be properly attendant upon, Architecture; . . .’”

Owen Jones,



P.O. Box, 822, Southington, CT 06489 (203) 621-2188

Goldleafing • Glazing • Stencilling • Marbeling • Graining • Restoration Consultant

Circle No. 510

Flooring that Fits  
First, Last  
and Always

(207) 897-5211

P.O. BOX 146 EAST LIVERMORE, MAINE 04228

## Aristocast Originals

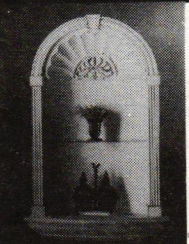

- Niches • Crown Moulding
- Trim • Fireplaces •
- Ceiling Medallions •
- Corbels • Archways •
- Columns • Porches •
- Oak Beams •

Buy at factory prices from the world's finest producer

### ARISTOCAST ORIGINALS INC

Dept. TB, 6200 Highlands Parkway, S.E.  
Suite 1, Smyrna, GA 30082  
Tel. 404 333-9934-9935 Fax. 432-0232

Dealer and manufacturer's agent inquiries welcome

FREE 28 page full color catalogue

Circle No. 118





Division 10  
SPECIALTIES

# Bird BARRIER

NIXALITE BIRD CONTROL



Nixalite architectural bird control protects any exterior structure contour from annoying bird defacement. Approved for historic sites and national monuments NIXALITE is an inconspicuous, humane and virtually maintenance free solution to bird problems. Call, fax or write for details.

**NIXALITE of AMERICA**  
 1325 - 97 AVE. - BOX 727  
 EAST MOLINE, IL 61244 - 309-755-8771  
 800-824-1189 - FAX 309-755-0077  
 SPECIALISTS IN BIRD CONTROL

Circle No. 37



FINE EUROPEAN  
FAUCETS AND  
ACCESSORIES

**WATERCOLORS**

GARRISON ON HUDSON NEW YORK 10524 914 424 3327

Circle No. 46

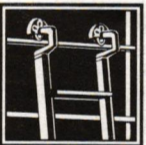

Division 11  
EQUIPMENT

## Ice-Cold Storage

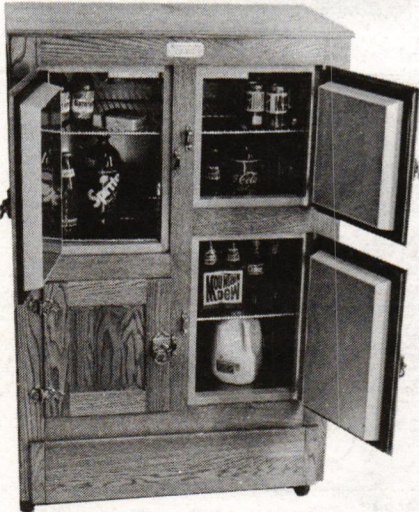

Charles B. Cushway, refrigeration expert, and his three sons — Michael, Kevin, and Charles, Jr. — have acted on their fascination with old-fashioned iceboxes: They manufacture them in Paris, Mich. under the name Northern Refrigerator Co.

The solid oak electric iceboxes are lined with stainless steel and have solid brass fittings. Because each refrigerator is manufactured to order, dimensions are flexible: Volume, 9-16 cu. ft.; height, 50-68 in.; width, 33-35-3/4 in.; front panel, 3 or 4 doors (some even have a freezer compartment). Prices range from \$2,025 for the



Division 14  
CONVEYING SYSTEMS

hand operated **WHITCO**

# dumbwaiters

**VINCENT WHITNEY COMPANY**  
 MANUFACTURERS • SASH HARDWARE • DUMB WAITERS  
 1760 Bridgeway/P.O. Box 335  
 Sausalito, CA 94966/(415) 332-3260  
 SERVING THE BUILDING INDUSTRY SINCE 1929

Circle No. 502

## Trouble With Stairs? Here's A Lift!

The Cheney Company has been making chair lifts for over 55 years. Each chair is custom made for any configuration of staircase: Straight, curved, even spiral. Four models range in price from \$2,700 to \$7,000, depending on the stair design.

Seats swivel, arms rotate and flip up, footrests fold, and seat belts retract. Some models are available in colors with rails in an accented color; basic models are all brown. Controls are on the arm, and there are landing call-and-send controls for remote use (also lights on housing). Chairs can bear up to 300 lbs., are UL listed, come with a limited warranty, and can be installed in a few hours.

Rails fit (unobtrusively) within 7 in. of the wall, and the footrest is 6 in. above the steps. Chairlifts can be in-



stalled over carpeting, and removal leaves virtually no trace.

For information about chairlifts, wheelchair lifts, or residence elevators, contact: **The Cheney Company, 2445 South Calhoun Rd., Box 51188, Dept. TB, New Berlin, WI 53151 (800) 782-1222. CSI# 14400 — JL**



Division 15  
MECHANICAL

# VERMONT SOAPSTONE Co.

Miners and Manufacturers Since 1850

Authentic soapstone sinks made in the traditional manner for kitchen, bath or greenhouse. Custom-made to your print.

Also: Custom cutting of fire places, countertops, and table tops.  
 Call or write for a quotation

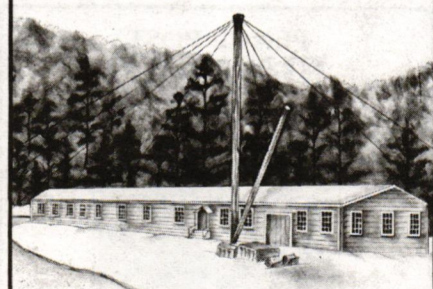

Stoughton Pond Rd.  
 P.O. Box 168 TB  
 Perkinsville, Vt. 05151-0168  
 (802) 263-5404

Other soapstone items available -  
 Griddles, Bootdriers & Bun Warmers

Circle No. 372

Northwind 9 (shown: all refrigerator, 3 doors) to \$3,495 for the Glacier 16 (refrigerator/freezer, 4 doors).

For more information, contact: **Northern Refrigerator Co., 21149 Northland Dr., Dept. TB, Paris, MI 49338 (616) 796-8007. CSI# 11450 — JL**

# BATHROOM Machineries



**Early American Bathroom FIXTURES & ACCESSORIES**  
 Classic Brass & Hard-To-Find Parts  
 Send \$3 For Complete Color Catalog

BOX 1020-TB • MURPHYS, CA 95247  
 (209) 728-2031

Circle No. 172

## SMITH-CORNELL, INC. Plaques of Distinction

THIS PROPERTY HAS BEEN  
 PLACED ON THE  
**NATIONAL REGISTER  
 OF HISTORIC PLACES**  
 BY THE UNITED STATES  
 DEPARTMENT OF THE INTERIOR

P.O. Box 686 TB PH: 219-925-1172 (IN)  
 Auburn, IN 46706 800-325-0248

Circle No. 53

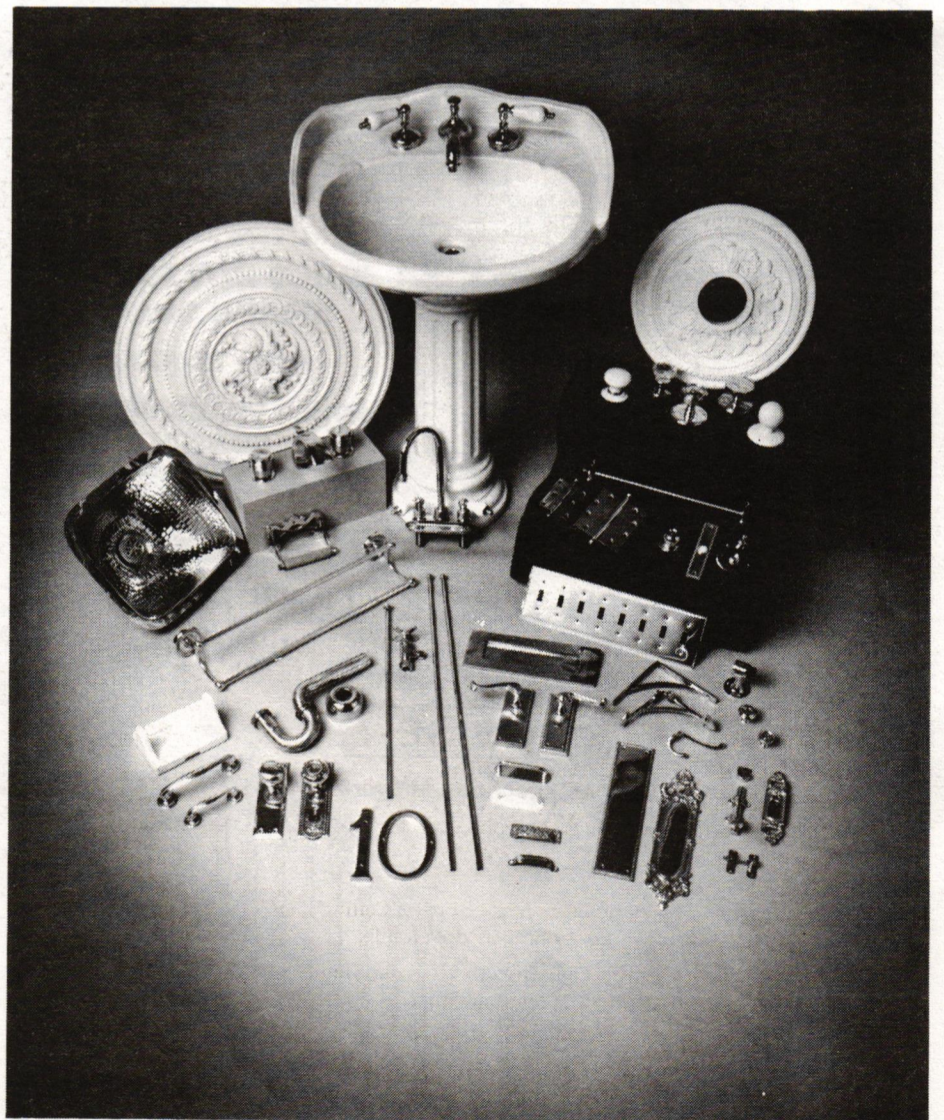

## Everything for the Traditional Building.

Decorative Hardware ~ Plumbing Fixtures & Accessories  
 Architectural Trims & Medallions

CATALOG \$2.00  
 CONSULTANT AVAILABLE  
**Restoration Works Inc.**

810 Main Street  
 Buffalo, N.Y. 14202  
 (716) 856-8000  
 Circle No. 41

## Your Award-Winning Source for Elegant Woodwork



Everything you need in Victorian gingerbread, turnings and carvings, in premium grade solid hardwoods. Factory-direct savings.

Period Bars, Backbars, Servers, Ceilings, Seating, Gazebo Kits & accessories.

We'll build to your specifications, supply any or all component parts. Complete custom design services.

Interior/exterior restoration projects, Victorian to Ultra-Contemporary, our specialty.

Send for Catalog. Over 135 color pictures of products and design ideas. \$4.50. Free if ordered on Company letterhead.

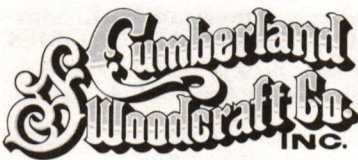

Best of Show, Blue Ribbon, Expo Show.



Expo Blue Ribbon Winner

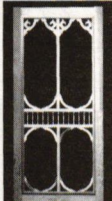

Dept. 190

Office hrs. 8 AM to 4 PM Mon.-Fri. EST

Post Office Drawer 609 Carlisle, PA 17013

(717) 243-0063 (800) 367-1884 Outside PA FAX (717) 243-6502

Circle No. 131

## EXTERIOR WOOD SHUTTERS

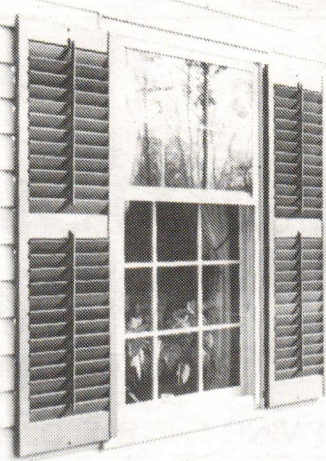

Hard-To-Find Wood Shutters with moveable louvers can be used outdoors or in. Fixed louver, raised panel, and custom arches also available. Order unfinished or primed and painted. Hinges and holdbacks shipped daily by UPS.

Brochure: (203) 453-1973

SHUTTERCRAFT 282 Stepstone Hill  
Guilford, Conn. 06437

Circle No. 44

## the Original CROSS VINYLattice



Never Needs Painting

Now or soon to be available at  
over 1000 fine stores

Lasts A Long Time

For more information call  
1 800 521-9878

Circle No. 23

## NEW ENGLAND WOODTURNERS

203-776-1880

"...we're turning your  
world just a  
bit nicer..."

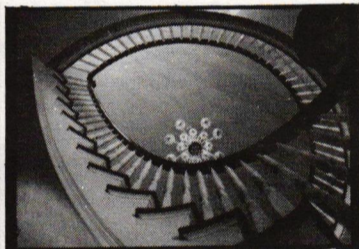

SEE US AT  
BOOTH 559  
AT THE

BUILD BOSTON  
TRADE SHOW

NOV. 15-16-17

WORLD TRADE CENTER  
BOSTON

Circle No. 295

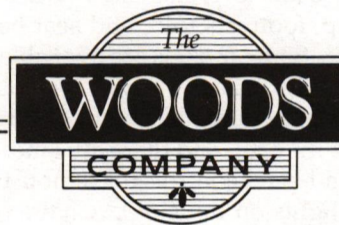

Rare & Beautiful  
Antique Lumber

Wide Plank Flooring  
Mouldings & Millwork

Antique Heart Pine,  
Oak, White Pine, Chestnut  
Select New Hardwoods

For Brochure  
Write

2357 Boteler Road  
Brownsville, Maryland 21715

or Call

Office 301-432-8419  
Shop 301-582-4535

Circle No. 213

Top Quality Precision Millwork  
CASINGS • BASES • CROWNS • CORNER BLOCKS  
**VICTORIAN ELEGANCE**  
DOORS • GINGERBREAD • WAINSCOT  
LARGEST INVENTORY OF VICTORIAN  
MOULDINGS & MILLWORK ANYWHERE

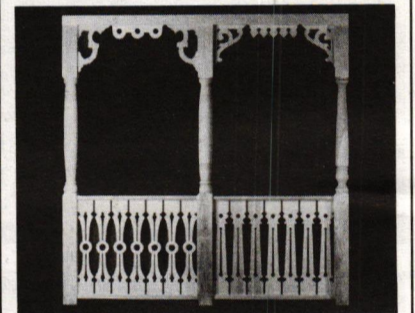

Specializing in Customer Service  
Buy Direct From Manufacturer  
Top Quality, Precision-made Products  
Premium & Commercial Grades Available  
No Minimum Order - Rush Orders are No Problem  
We're Experts in Shipping & Packaging  
Full Color Catalog with lots of Construction Ideas

Send for your free catalog.  
Phone or write to:  
P.O. Box 2987-TB3  
Durango, Colorado 81302  
303/259-5915

Circle No. 45

## BOISE MOULDING & LUMBER CO.

116 EAST 44TH STREET BOISE, IDAHO 83714

PHONE (208) 322-6066

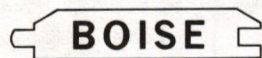

BRAND  
Architectural Millwork



MANUFACTURERS OF CUSTOM ARCHITECTURAL MILLWORK

DOORS • WINDOWS • PANELING • STAIRWAYS • MANTELS • HARDWOOD & SOFTWOOD MOULDINGS

Circle No. 317

## FENCE POST FINIALS

Distinctive wood finials in classic styles  
• 4"-15" diameters • custom services available.

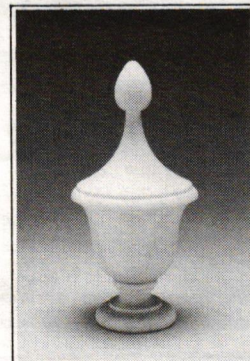

Call or write for brochure:  
BOSTON TURNING WORKS  
architectural woodturning  
42 Plympton Street,  
Boston, Massachusetts 02118  
617-482-9085

Circle No. 475

## Protect Wall Corners The Great Old-fashioned Way

Our unfinished **Cornerbeads** compliment any period or decor. They're among hundreds of hard-to-find, "old style" items we have to enhance your old house or capture a bit of the past in your newer home. Each cornerbead is 4 7/8" x 1 1/2" dia., with 90° notch.  
**Beechwood.** Ea. \$9.75; 6 or more \$8.75.  
**Oak.** Each \$13.50; 6 or more \$12.00. Add freight: \$2.50 (1-5); \$6.50 (6 or more).  
WI residents add 5% tax. VISA/MC, or AMEX accepted.

To Order Call TOLL-FREE  
1-800-556-7878  
In Wis.: 414/542-0685  
Or, send for more information.

Crawford's  
Old House Store

550 Elizabeth St. Rm. 30 • Waukesha, WI 53186  
Dealer Inquiries Invited

Circle No. 22

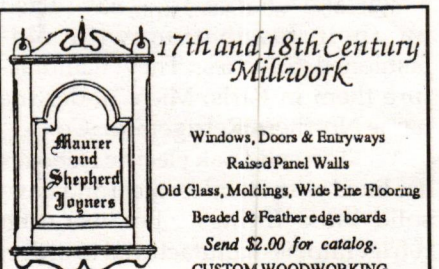

17th and 18th Century  
Millwork

Windows, Doors & Entryways  
Raised Panel Walls  
Old Glass, Mouldings, Wide Pine Flooring  
Beaded & Feather edge boards  
Send \$2.00 for catalog.  
CUSTOM WOODWORKING

Maurer & Shepherd Joiners  
122 Naubuc Avenue  
Glastonbury, Connecticut 06033  
(203) 633-2383



Division 6  
WOOD & PLASTICS

The Many Ways To Climb To The Top:

# STAIRCASES & PARTS

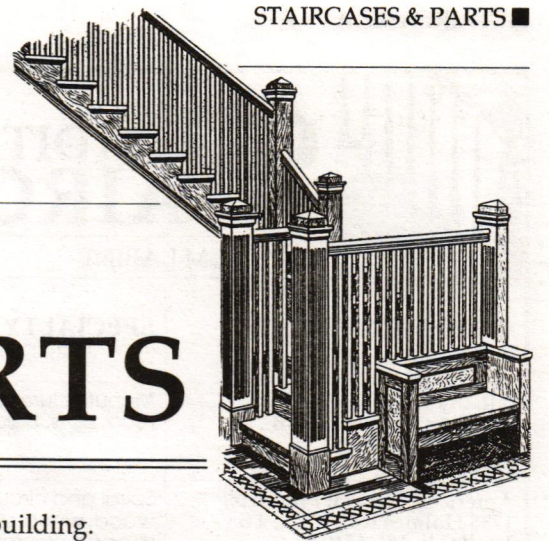

It's difficult to find a carpenter who can build a staircase these days. But there are many specialty shops that can provide you with everything from an economical metal spiral to an elaborate "Gone With The Wind" curving double stairway.

BY CLEM LABINE

**B**uilding a staircase (other than simple cellar stairs) is the ultimate test of a carpenter. And it's a test that most of today's house carpenters would flunk. In our age of specialization, the knowledge of how to lay out and detail staircases and handrails resides in perhaps no more than 100 shops in the U.S.

If you've ever watched a pro lay out a curved stair and handrail, it's not difficult to see why stairbuilding is such a rare skill. Stairbuilding depends on an extensive knowledge of solid geometry. And most woodworkers today simply don't have the skills in mathematics and geometry necessary to cope with curved stairs.

Stair construction has always been complicated. Housebuilding manuals of the 19th century devoted almost half of their pages to stair layout . . . replete with diagrams that even today's successful stairbuilders have difficulty deciphering. Part of the problem lay with the 19th century authors: They tended to combine several steps in a single diagram. So if you don't already know the subject intimately, it's hard to figure out the layout sequences.

## Throwing A Curve

Generating the rail for a curved stair is the most difficult task in all of woodworking; it's also the operation that separates the men from the boys among the stairbuilding shops.

When you look at the curved rail made by even some well-known shops, it's not unusual to see awkward transitions where the curve changes. That's because the rail wasn't laid out by the old-fashioned tangent method. When selecting a shop to do a curved staircase, one clarifying question is: "How do you generate your curved handrail?" If the answer comes back something like: "We generate our handrail out of solid using the old one-plane tangent method," then you know you've found someone who really knows about

stairbuilding.

If the shop doesn't use the old tangent method for rail with compound curves, you'd be well advised to check the handrail on their past work that most closely resembles your job. See if the rail has the graceful smooth flow to the curve that you're looking for. Rails on elliptical stairs are the most difficult.

## Who's In The SourceList

You get the idea from Sweet's Catalog that there's only a handful of companies in the stair business. But we have collected information on 53 suppliers of stairways and stair parts . . . ranging from individual craftsmen to large stairbuilding factories.

Although the accompanying SourceList is the most complete list of staircases and parts suppliers we've seen in print, we recognize it is not complete. A few of the larger stairbuilders didn't reply to our requests for information (perhaps they don't consider themselves part of the traditional products marketplace). And there are undoubtedly some smaller suppliers that we just aren't aware of.

## FOR HOMES OF CHARACTER

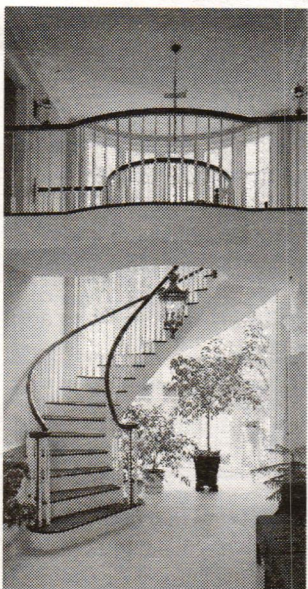

Arcways, Creators of superbly crafted custom curved staircases, rail and balcony treatments for commercial and residential applications. Specialists in Retrofit and Renovation. As seen on the PBS network show "This Old House." Please send \$1.00 for brochure. Call or write



1076 Ehlers Road  
P.O. Box 763  
Neenah, WI 54956  
Tel: 414-725-2667  
FAX: 414-725-2053

MADE IN THE USA



Circle No. 492

## CUSTOM MILLWORK

- Moldings
- Random width T&G Flooring
- Panelling
- Native & Exotic Woods
- Both KD & Air Dried

DHM CABINETMAKERS, INC.  
FINE FURNITURE & INTERIORS

ROUTE 4, BOX 173  
FLOYD, VIRGINIA 24091  
703-745-3825 FAX 703-745-3875

Circle No. 493

## ARCHITECTURAL TIMBER & MILLWORK

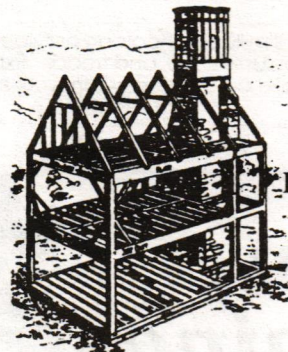

RESTORATION WOODWORKING  
Cabinets • Doors & Entries  
Stairs, Columns & Balustrades  
Paneling & Mouldings • Gazebos & Arbors

TIMBER FRAMED HOUSES  
AND BARNES  
18th Century • Japanese • Contemporary  
Mortise & Tenon Joinery  
Hewn or Hand Planed Finishes

HEART PINE FLOORING • STEEPLES, CUPOLAS & HISTORIC FACADES

Specialists in All Restoration Materials  
Wood, Iron, Copper, Terra Cotta, Plaster, Stained Glass & Gold Leaf Work

280 Stanley Street • Amherst, Mass. 01002 (413) 256-8785

Circle No. 329

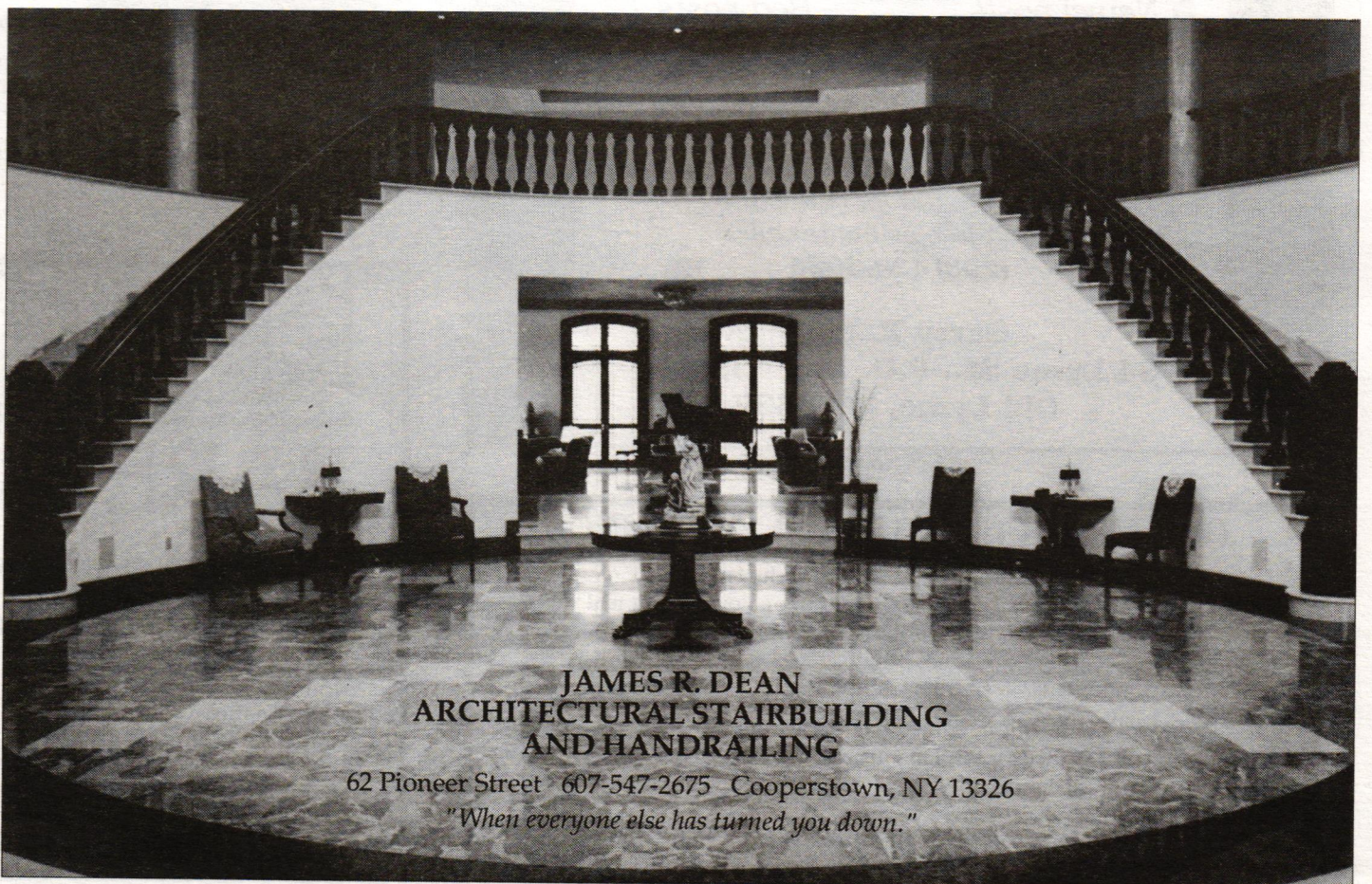

JAMES R. DEAN  
ARCHITECTURAL STAIRBUILDING  
AND HANDRAILING

62 Pioneer Street • 607-547-2675 • Cooperstown, NY 13326

"When everyone else has turned you down."

Circle No. 473

# TRADITIONAL BUILDING'S STAIRCASES & PARTS SourceList

CSI# 06200

BY CLEM LABINE

COMPANY	SPECIALTY	Literature	COMPLETE STAIRS			STAIR PARTS		
			Spiral	Curved	Straight	Newels/ Balusters	Treads/ Nosing	Rail
Albany Woodworks P.O. Box 1155, Dept. TB Albany, LA 70711 (504) 567-1155	Manufactures custom stair parts from antique heart pine: Treads, risers, skirts, balusters, straight handrail, and newels.	Free Circle No. 466				✓	✓	✓
American General Products 1735 Holmes Rd., Dept. TB Ypsilanti, MI 48197 (313) 483-1833	Spiral and circular stairs in many styles. Spiral stairs come in all-wood, wood-and-steel, or all-steel designs. Circular stairs are shipped assembled; spirals are shipped knocked down. Oak stair parts available.	Free Circle No. 467	✓	✓	✓	✓	✓	✓
American Heirlooms, Inc. Rt. 2 Box 1120, Dept. TB Bean Station, TN 37708 (615) 993-2688	Stock and custom balusters and newels. Balusters and newels can be made from any wood specified. Pine or poplar recommended in softwoods.	Free Circle No. 468				✓		
American Ornamental Corp. 5013 Kelley St., Dept. TB Houston, TX 77026 (713) 635-2385	Metal spiral stairs are shipped as completely assembled units. Welded construction avoids rattles of nut-and-bolt construction; special design hides or eliminates 88% of all welds. Wood handrail option available.	Free Circle No. 469	✓					
American Stair Builder 190 Highland Place, Dept. TB Brooklyn, NY 11208 (718) 647-5600	Custom stair builder can provide every variety of stair: Curved, straight, spiral. Works with any wood specified. Smaller stairs are shipped in one piece. Restoration and new construction.	Free Circle No. 470	✓	✓	✓	✓	✓	✓
Architectural Accents 1547 Ridge Road, Dept. TB Munster, IN 46321 (219) 838-4331	Stock and custom-designed newel posts. They can be matched to any spindle or architectural style in wide variety of wood types. Available with or without a lighting fixture or finial.	Free Circle No. 471				✓		
Architectural Lathe & Millwork 316 South Bernadotte, Dept. TB New Orleans, LA 70119 (504) 482-0980	100% custom turnings shop: Newels, balusters, rail. Can provide reeding and fluting, as well as hollow stave-work assemblies. Has 22-ft. lathe; turnings to 17 ft. Works from drawings or sample.	Free Circle No. 472				✓		✓
Architectural Stairbuilding & Handrailing 62 Pioneer St., Dept. TB Cooperstown, NY 13326 (607) 547-2675	Small custom shop that can build any type of stair or handrail. Specializes in developing handrail out of solid plank using the traditional tangent method, resulting in a smooth line no matter how complex the curve.	Free Circle No. 473	✓	✓	✓			✓
Arcways 1076 Ehlers Rd., Dept. TB Neenah, WI 54957 (414) 725-2667	Large stairbuilding shop supplies both stock and custom wood stairs: Spiral, curved, straight. Also has a wide selection of treads, balusters, newels, and rail that are sold mainly through distributors.	Free Circle No. 492	✓	✓	✓	✓	✓	✓
AulStair 1330 Union Hill Rd., Dept. TB Alpharetta, GA 30201 (404) 475-3696	Shop manufactures wooden spiral, curved, and straight stairs — both stock and custom. All spirals come in kit form, ready for on-site assembly.	Free	✓	✓	✓			
Barewood, Inc. 106 Ferris St., Dept. TB Brooklyn, NY 11231 (718) 875-9037	Custom architectural millwork shop can provide a wide variety of stair parts: Newels, balusters, rail, and treads. Experienced in working with architects and contractors. Can work from drawings or a sample.	Free Circle No. 167				✓	✓	✓



## Partelow's Custom Wood Turnings

- Balusters for staircases, decks, porches and fences
- Newel posts
- Porch posts to 12'
- Column bases
- Fluting
- Spiral rope twist
- Finials
- Furniture parts
- Bed posts
- Lamps
- Spoon foot legs

No minimum order. Shipment coordination  
Send \$2.00 for catalog.  
For a free estimate call:  
**(203) 434-2065**

**Garry R. Partelow**  
34 Lyme St., P.O. Box 433  
Old Lyme, CT 06371

Circle No. 496

## The Spiral Stair That Installs In 10 Minutes!

The most advanced metal spiral stairs in the world:



- Not a kit! Our "Americana" and "El Grande" spiral stairs are welded into a single unit... including the handrail.
- No fussing with boxes of parts & bolts.
- More rigid than bolt-together units; no shakes and rattles.
- Revolutionary stair tread: Pressed and molded one-piece steel unit with rounded corners hides all welds.
- 1" sq. handrail balusters with twists to add strength and beauty.
- Wood handrail option available.

Spiral Stairways are our only business. We sell more quality units worldwide than any other company. Write or call for free brochure.

### American Ornamental Corporation

5013 Kelley Street, PO Box 21548, Houston, TX 77026 (713) 635-2385 (800) 231-3693

Circle No. 469



## BAREWOOD INC.

Fine custom woodworking and carving artistically executed cherished pieces lovingly repaired or recreated

**CUSTOM FABRICATION**  
**EXPERT REPAIRS ••• REPRODUCTION**

Windows	Fireplace Mantle/Mirrors
Doors/Sashes	Cornices
Custom Moulding/Millwork	Wainscoting/Panelling
Staircase Parts	Woodturning/Spindles/Columns
Decorative Woodcarving	Handrails
Furniture/Cabinets	

**106 Ferris Street, Brooklyn, New York 11231**  
**(718) 875-9037**

Circle No. 167

## ONE PIECE CURVED WOOD MOULDINGS

*Unicuru*™ Radius Products

All of our products are laminated and bent in one piece from real wood. We can supply you with the following quality radius products:

- Interior Trim
- Brick Mould
- Windows
- Window Components
- Grille Components
- Cased Openings

*Flexicrown*™ is a split bending wood crown mould consisting of eight, twelve foot long pre-milled pieces. They are applied one at a time to the wall by a trim carpenter and will bend either concave or convex down to a 4-0 radius. The cost is about 1/3 that of solid curved crown.

**MARIETTA MILLWORKS, INC.**  
PO Box 7719 • Marietta, GA 30065-1719 • (404) 425-8724 • FAX 425-0293

Circle No. 479

## THE BEST BUYS IN SPIRAL STAIRS!



**Metal Only**  
**\$425**

F.O.B. Broomall, PA  
For 3'6" Diam. Kit  
(Hts. 7'6" to 8'4")

**Oak Only**  
**\$1575\***

F.O.B. Broomall, PA

\*For 4' Diam. - Hts. 8' to 8'6"  
(Shown: 6' diam. kit  
with in-between spindles)

©The Iron Shop '90

**Easy-to-Assemble Kits.**

Other diameters and floor-to-floor heights at comparable savings.

**For Free Color Brochure**  
**Call Toll Free 1-800-523-7429**  
(In PA call collect: 215-544-7100)

**Or Write:** (Please specify Oak, Metal or both)  
The Iron Shop, Dpt. OTB70, Box 547  
400 Reed Rd., Broomall, PA 19008

**Now! Showroom/Warehouse Locations in:**  
Pomona, CA (714) 598-5766 Sarasota, FL (813) 923-1479  
Houston, TX (713) 789-0648 Chicago, IL (708) 952-9010  
**NEW** Stamford, CT (203) 325-8466

From the Leading Manufacturer of  
Spiral Stair Kits . . .

**THE IRON SHOP®**

We welcome VISA, MasterCard, AMEX & Discover

Circle No. 356

## THOS. K. WOODARD

AMERICAN  
ANTIQUES & QUILTS

835 MADISON AVENUE, DEPT. TB, NEW YORK, N.Y. 10021 (BET. 69TH & 70TH STS.) (212) 988-2906



### WOODARD WEAVE™

Classic American Woven Rugs

Room-size area rugs and runners  
Catalogue \$5.00

Circle No. 503

## WORTHINGTON

THE PREMIER NAME IN COLUMNS

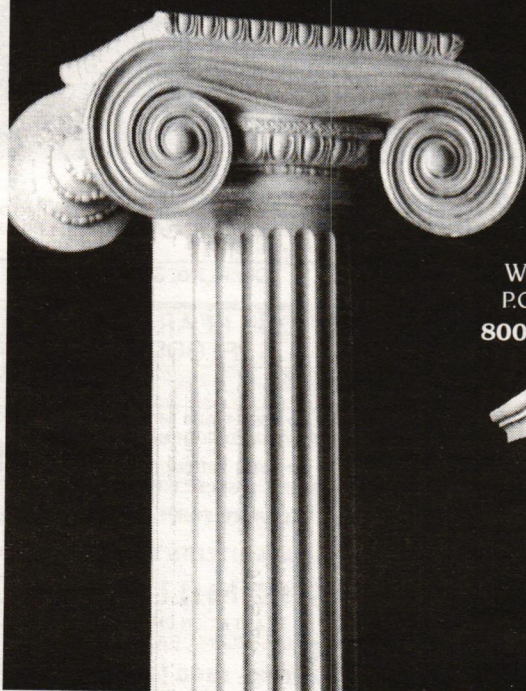

Catalog \$3.00

WORTHINGTON GROUP, LTD.  
P.O. Box 53101 • Atlanta, GA 30355  
800-872-1608 404-872-1608

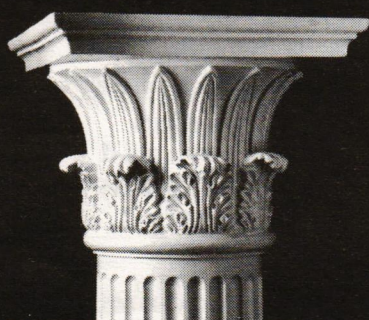

Circle No. 163

# THE VERY LAST SHUTTER YOU'LL EVER NEED

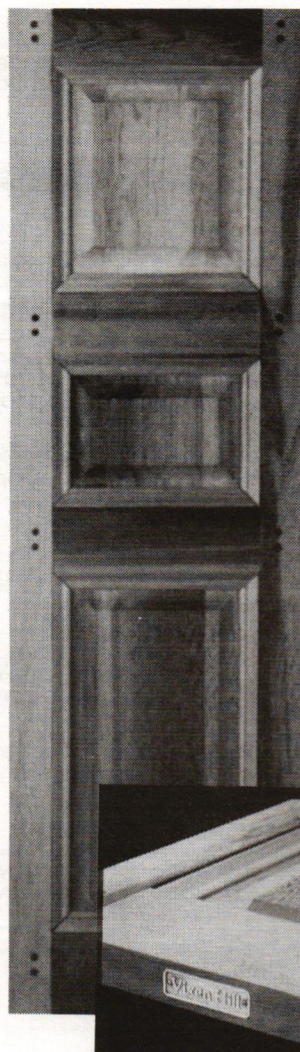

### Our all-cedar shutters endure for generations.

Cheap pine shutters with steel staples can fail in as few as five years. And plastic is . . . well, plastic. So to build the Vixen Hill shutter, we use only clear, old growth western red cedar. Joints are mortise-and-tenon with teak locking pins. Both panels and louvers are of generous dimensions, ensuring lasting beauty for generations.

We're so confident that our shutters will last, we put a brass signature plate on every one.

For a detailed brochure featuring our many louver and raised-panel styles in both standard and custom sizes, contact:

### The Vixen Hill Cedar Shutter

Main Street  
Elverson, PA 19520

**(215) 286-0909**

Circle No. 123

## ROCCA NOTO

SCULPTURE STUDIO, INC.

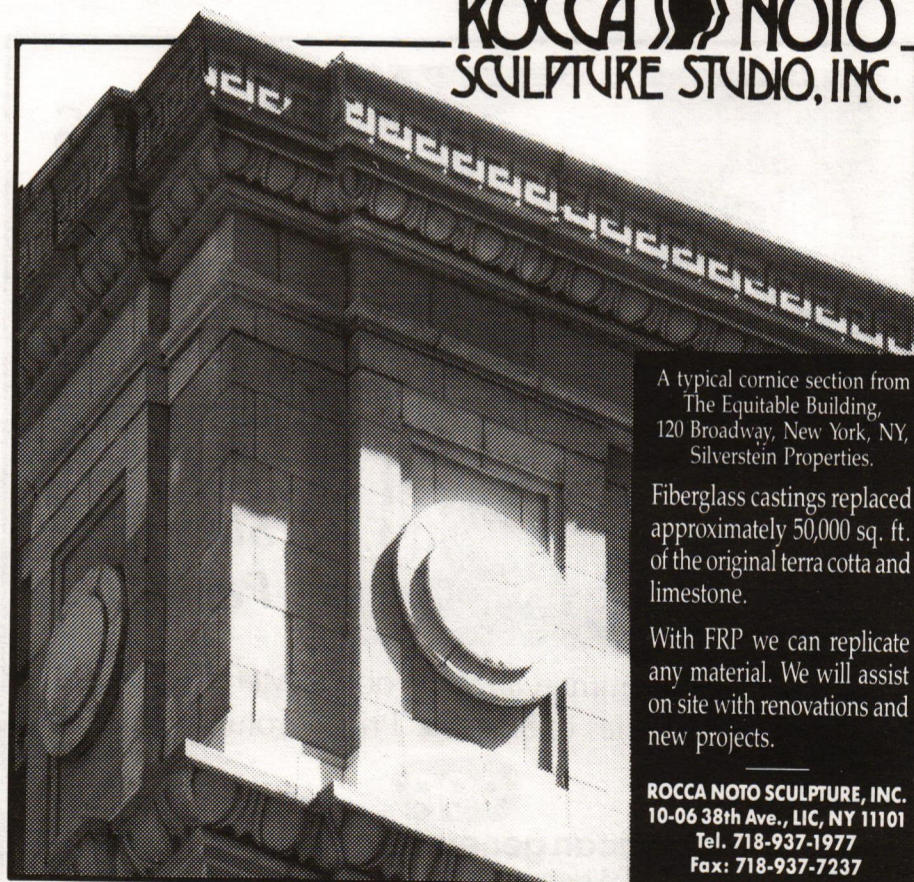

A typical cornice section from  
The Equitable Building,  
120 Broadway, New York, NY,  
Silverstein Properties.

Fiberglass castings replaced  
approximately 50,000 sq. ft.  
of the original terra cotta and  
limestone.

With FRP we can replicate  
any material. We will assist  
on site with renovations and  
new projects.

**ROCCA NOTO SCULPTURE, INC.**  
10-06 38th Ave., LIC, NY 11101  
Tel. 718-937-1977  
Fax: 718-937-7237

Circle No. 422



P.O. Box 859  
Salisbury, North Carolina 28144  
(704) 633-2421

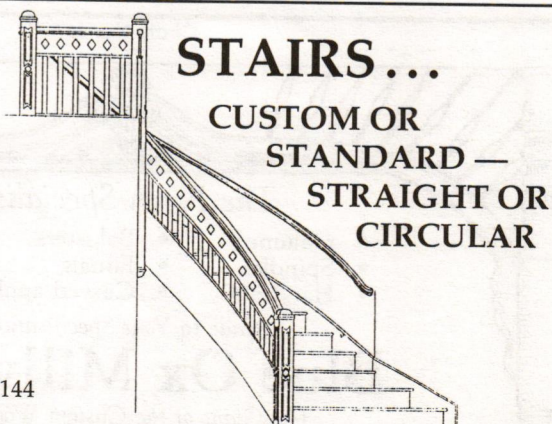

### STAIRS...

CUSTOM OR  
STANDARD —  
STRAIGHT OR  
CIRCULAR

Circle No. 495

STAIRCASES & PARTS SourceList, continued									
COMPANY	SPECIALTY	Literature	COMPLETE STAIRS			STAIR PARTS			
			Spiral	Curved	Straight	Newels/ Balusters	Treads/ Nosing	Rail	
<b>Boise Moulding &amp; Lumber Co.</b> 116 East 44th St., Dept. TB Boise, ID 83714 (208) 322-6066	Major architectural millwork shop that supplies both stock and custom stairway parts: Balusters, newels, hand rail, treads & risers. Will also build curved and straight stairs to your specifications.	Free Circle No. 317	✓	✓	✓	✓	✓	✓	✓
<b>Bolton Woodturning</b> P.O. Box 9596, Dept. TB Bolton, CT 06043 (203) 742-6731	Architectural wood turnings — stock or custom — including newels and balusters. Any wood, any shape, any size, any quantity. No minimum.	Free Circle No. 474				✓			
<b>Boston Turning Works</b> 42 Plympton St., Dept. TB Boston, MA 02118 (617) 482-9085	Custom wood turning: Balusters, newel posts, fence posts, finials, porch posts, columns, column bases, and caps. Can work from samples or architect's drawing. No minimum.	Free Circle No. 504				✓			
<b>Bruce Post Co.</b> P.O. Box 332, Dept. TB Chestertown, MD 21620 (301) 778-6181	Produces newel posts, ball finials, and acorn finials. All heart redwood newels are sanded and ready for finish. Custom styles available upon request.	Free Circle No. 375				✓			
<b>Challis Stairways, Inc.</b> 11585 South State, Dept. TB Sandy, UT 84070 (800) 242-5547	Manufacturer of custom wood stairs in straight, spiral, and circular configurations. Also: A line of stair and handrailing components that includes rails, newels, balusters, fittings, treads, and risers.	Free	✓	✓	✓	✓	✓	✓	✓
<b>Coffman Stair Parts</b> 1000 Industrial Rd., Dept. TB Marion, VA 24354 (703) 783-7251	Hardwood stair parts and preassembled curved and spiral stairs in red oak or beech. Starting steps, treads & risers, rails, newels, balusters, fittings, flutes & twists available through distributors.	Free	✓	✓	✓	✓	✓	✓	✓
<b>Cooper Stair Company</b> 1331 Leighton Rd., Dept. TB Mundelein, IL 60060 (312) 362-8900	Manufactures custom-fitted hardwood staircases from a wide variety of styles. Straight, circular, spiral, and L-shaped configurations available.	Free	✓	✓	✓				
<b>Curvoflite</b> 205 Spencer Ave., Dept. TB Chelsea, MA 02150 (800) 445-7009	Architectural millwork shop that specializes in solid oak curved and spiral stairs — stock or custom. Large selection of handrail fittings, custom balusters, and stair parts.	Free	✓	✓	✓	✓	✓	✓	✓
<b>Custom Woodturning</b> 4000 Telephone, Suite B13 Houston, TX 77087 (713) 641-6254	Architectural woodturning shop produces balusters, newels, and handrail. They can work to your drawings or sample — or you can select from their collection of authentic period century patterns.	Free Circle No. 14				✓			✓
<b>Dahlke Stair Co.</b> P.O. Box 418, Dept. TB Hadlyme, CT 06439 (203) 434-3589	Small custom stairbuilding shop. Each stair is designed and fabricated individually; no catalog stair parts are ever used. All styles, in any wood specified.	Free	✓	✓	✓				
<b>Driwood Moulding Co.</b> P.O. Box 1729, Dept. TB Florence, SC 29503 (803) 669-2478	Supplies custom wood spiral and circular stairs over the entire U.S. Each stair is detailed for the specific application, with variations possible in wood species, layout, balusters, rails, and trim.	Free Circle No. 476	✓	✓					
<b>Dugwood Turners</b> P.O. Box 634, Dept. TB Richmond, VA 23205 (804) 788-8037	Small turning shop provides balusters, newels, rail, columns, and porch parts — 100% custom. Can work from a sample or your drawings.	Free Circle No. 477				✓			



## STAIRS

- Circular
- Spiral
- Straight

### Oak Stair Parts

Residential & Commercial ■ Wood & Metal Spiral Stairs  
12 Varieties of Stairs ■ Priced from \$480



**american general products, inc.**  
1735 Holmes Rd., Ypsilanti, MI 48197  
(313) 483-1833 out of Mich. 800-STAIRS-1  
FAX (313) 483-1410

Circle No. 467



Mansion Victorian Gingerbread

### Victorian Gingerbread

Porch Posts, Rails  
Newels & Balusters  
Choice of 3 Species!  
**REDWOOD  
CEDAR &  
CCA TREATED**

(800) 423-6589  
P.O. BOX 2220  
INDUSTRY, CA 91746

**mansion industries, inc.**  
Circle No. 361

## TURNED NEWEL POST

FOR DECKS AND STOOPS

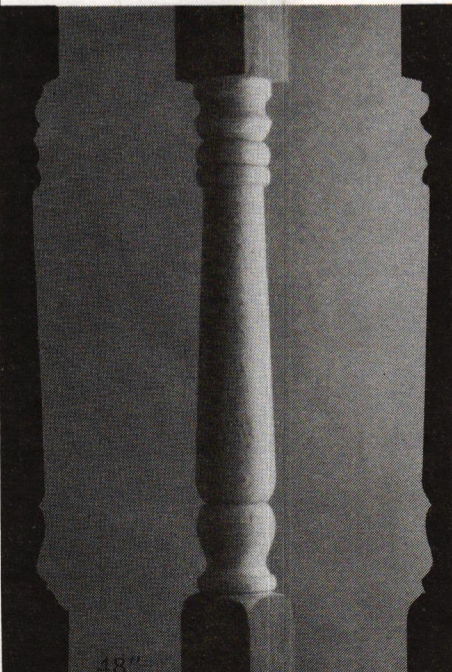



**BRUCE POST CO., INC.**  
CENTER-DRILLED ALL-HEART REDWOOD  
P.O. BOX 332, CHESTERTOWN, MD. 21620  
301-778-6181

Circle No. 375



*The Porch Specialists*

- Columns
- Balusters
- Spindles
- Finials
- Handrails
- Carved appliques

*Made to Your Specifications*

## Blue Ox Millworks

*The Giant of the Custom Woodshops*  
Free Brochure, \$6.00 informational pattern book  
Foot of X Street Eureka, CA 95501 (800)24-VICKY FAX (707)444-0918

Circle No. 203



*To project the image you desire—*

### Victorian Gingerbread Authentically Recreated

P.O. Box 2847  
Roseville, CA 95746  
(916) 791-7733

Circle No. 332

## ANTIQUE HEART PINE T & G FLOORING



REMILLED FROM ANTIQUE BEAMS  
CENTER MATCHED TONGUE & GROOVE

GRADES INCLUDE:  
CABIN \* PRIME \* SELECT PRIME \* CLEAR

FAST DELIVERY FROM OUR MILLS

"THE ARCHITECTS CHOICE"

### COASTAL MILLWORKS

112 PLANTATION CHASE  
ST. SIMONS ISLAND, GA. 31522  
912-634-1300 {24HRS}  
FAX 912-638-2778

Circle No. 319

# A Picture Says It All...

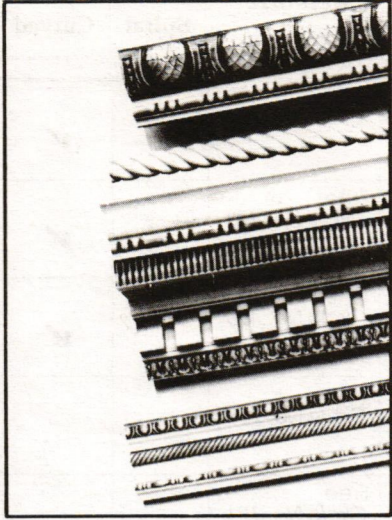

- CUSTOM MANTELS
- RAISED PANELING
- EMBOSSED WOOD MOULDING
- CURVED STAIRS
- CUSTOM DOORS
- DESIGN DEPARTMENT

Send \$6 for catalogs, credited against order.

## DRIWOOD

Ornamental Wood Moulding

P.O. Box 1729 • Department 90-6 • Florence, S.C. 29503 • (803)669-2478

Circle No. 476

## STAIR RUNNERS & RODS

A stair runner, with or without stair rods, makes a handsome addition to a staircase. But a bordered stair runner is an enhancement that should not be undertaken without careful planning. Installing a bordered runner on anything other than a straight stair becomes quite tricky when you try to figure out how to handle the border on the turns. For example, John Burrows, proprietor of J. R. Burrows & Co., notes that it often takes his installers longer to install a bordered runner on a staircase with landings than it does to carpet an entire room. Here are a few suppliers of stair runners and rods:

### STAIR RUNNERS

■ **J.R. Burrows & Co.** has about a dozen bordered patterns (authentic period designs dating from 1800 to 1920) that were designed specifically as stair runners. The most popular is the William Morris "Tulip & Lily" that was produced from 1870 to 1920. They are available in 27-in. and 36-in. widths. A narrow 22-1/2 in. could also be supplied for older stairs.

Many of the standard room patterns in Burrows' collection of authentic Wilton and Brussels carpets can also be made up into stair runners. The original 19th-century designs made specific provision for adapting part of the room border for a stair runner. Documented historical carpet patterns date from 1795 to 1920. Burrows also has a Federal period stair rod in the development stage. For detailed information, send \$5 and specify stair runners as your area of interest. Or call: 617-524-1795. J.R. Burrows & Co., P.O. Box 1739, Dept. TB, Jamaica Plain, MA 02130.

■ **Family Heirloom Weavers** creates authentic ingrain bordered stair runners in two 19th century patterns. (They can also weave ingrain carpet for entire rooms.) The runners come in a wide variety of color ways, and are reversible. Width is 22-1/2 in. Hair & jute underlayment also available. They also have simple Early American steel stair rods. Family Heirloom Weavers, R.D. 3, Box 59E, Red Lion, PA 17356 (717) 246-2431. Or Circle No. 508

■ **Thos. K. Woodard** has re-created the Early American craft of producing flat-weave carpet on hand looms. In addition to a wide variety of area rugs, they supply 42 patterns of stair runners. The colors and designs are based on historic documents from Shaker, Amish, Pennsylvania Dutch, and other Early American sources. Runners come 27 in. wide and any length. Thos. K. Woodard, 835 Madison Ave., Dept. TB, New York, NY 10021 (212) 794-9404. Or Circle No. 503

### STAIR RODS

■ **Ball & Ball** makes a single type of stair rod out of 1/2" solid brass rod with brass acorn finials. Two types of bracket are available; one for thin carpet and one for thick carpet with underlayment. Call for more details. Ball & Ball, 463 West Lincoln Highway, Exton, PA, 19341 (215) 363-7639.

■ **Heritage Brass** supplies solid brass stair rods and fasteners. Finials in urn or ball designs. Rods can be cut to any length. Free brochure. Heritage Brass Co., 820 W. Main St., Smethport, PA 16749 (814) 887-7777. Or Circle No. 490

■ **J.E. Smith Co.** carries Baldwin stair rods, in both solid brass and brass tubing. Come with final tip or plain end. 3-ft. lengths in stock for same-day shipping; other lengths are special order. J.E. Smith, 621 Bank St., Dept. TB, Waterbury, CT 06721 (800) 345-5625.

### ELEGANT, SOLID BRASS Stair Rods

Holds Stairway Carpet in Place  
Large 3/8" x 30" Polished Brass Rods

Ball, Urn or Pineapple Finials

Set of 13 \$137<sup>00</sup> ppd.

Includes Rods, Finials & Fasteners  
Singles \$12.00/Ea. MC, VISA, CK.

Easy, Fast Installation  
Custom Lengths

(814) 887-7777  
HERITAGE BRASS CO.  
820 West Main St., Smethport, PA 16749

NEW

Circle No. 490

### BOSTON TURNING WORKS

architectural woodturners

- Balusters
- Newel Posts
- Porch Posts
- Columns
- Column Bases/Caps
- Fence Post Finials
- Cylinders
- Corner Blocks

FAX your drawings or call in your specifications for immediate quotation. No minimum.

42 Plympton St., Boston, Mass. 02118  
617-482-9085 FAX 617-482-0415  
We ship daily via UPS to the entire U.S.

Circle No. 504

# ANTIQUE WIDE PINE FLOORING

## Antique Oak & Chestnut Available

Widths to 22" Wide

Antique Wide Pine and Hard Long Leaf Yellow Pine  
Lengths up to 18' Long - Widths up to 14" Wide  
Planed and Ready to Install

For price info, call Mark Phillips: (508) 948-2722  
Northfield Restorations, Box 741, Rowley, Mass. 01969



Circle No. 326

**Classic Decorator Wood Mantels.**

Add elegance to a new or existing fireplace with a handcrafted wood mantel. 40 styles — from Louis XV to Williamsburg Colonial to Modern. Send for FREE brochure. Readybuilt Products, Dept. TB, 1700 McHenry St., Baltimore, MD 21223. (301) 233-5833

**READYBUILT**  
Keeping families warm for more than half a century.

Circle No. 217

**Conklin's Authentic Antique Barnwood and Hand Hewn Beams**

**Pennsylvania Wall Stone & Flagstone**

- Barnwood: grey, silver grey, brown, red
- 50,000-100,000 sq. ft. in stock
- Random length and width
- Plank flooring

For Further Information Call Or Write  
**Leo Conklin**  
RD 1, Box 70  
Susquehanna, PA 18847  
717-465-3832

WHOLESALE ONLY

Circle No. 115

**Balusters & Newels**  
Custom or Stock

For more information or brochure, please call or write:  
**American Heirlooms**  
Route 2 • Box 1120  
Bean Station, TN 37708  
615-993-2688

Circle No. 468

## Architectural Wood Turnings

20 years of woodturning experience.

- Staircase Balusters
- Newel Posts
- Porch Balusters
- Porch Posts
- Column Bases/Caps
- Table Legs
- Chair Parts
- Cylinders
- Club Foot Legs
- Custom Turning

Any wood, any shape, any size, any quantity. We have supplied custom wood turnings to a variety of industries, ranging from furniture to construction; no minimum. Send all correspondences to:

**Bolton Wood Turning**  
Leon Kassler  
P.O. Box 9596  
Bolton, CT 06043  
(203) 742-6731

Circle No. 474

STAIRCASES & PARTS SourceList, continued

COMPANY	SPECIALTY	Literature	COMPLETE STAIRS			STAIR PARTS		
			Spiral	Curved	Straight	Newels/ Balusters	Treads/ Nosing	Rail
Duvinage Corp. P.O. Box 828, Dept. TB Hagerstown, MD 21741 (301) 733-8255	Major supplier of custom spiral, curved, and circular staircases — mainly in contemporary styles. Also produces metal spiral staircase kits in diameters from 3 ft. 6 in. to 5 ft.	Free	✓	✓				
Goddard Mfg. Co. Box 361, Dept. TB Logan, KS 67646 (913) 689-4341	Spiral staircases built to your specs. Available in welded steel or solid wood construction. Can be tailored to meet various building codes. Custom rail option. Circular staircases also available.	Free Circle No. 478	✓	✓				
Goodman Lumber Co. P.O. Box 859, Dept. TB Salisbury, NC 28144, (704) 633-2421	Architectural millwork shop that does custom stairs. Straight and circular stairs of any design, any wood. Also supplies L. J. Smith stair parts for standard straight-run stairs.	Free Circle No. 495		✓	✓	✓	✓	
Goodwin Lumber Co. Rt. 2 Box 119AA, Dept. TB Micanopy, FL 32667 (904) 373-9663	Custom stair parts — including treads, bullnose, and handrail — made from virgin antique heart pine. Rare curly ("Burley") heart pine and heart cypress also available. Solid plank treads standard.	Free Circle No. 253				✓	✓	✓
Historical Arts & Casting 4130 West 1939 South, Dept. TB Salt Lake City, UT 84104 (801) 974-0242	Fabricates custom metal railings (cast and wrought) for major commercial, institutional, and governmental buildings.	Free Circle No. 121						✓
Henderson, Black & Greene P.O. Box 589, Dept. TB Troy, AL 36081 (205) 566-5000	Circular staircases are fully assembled in the factory, then balustrade is removed for shipping purposes. Stair arrives at job site ready for installation in rough opening.	Free		✓				
The Iron Shop P.O. Box 547, Dept. TB Broomall, PA 19008 (215) 544-7100	Major manufacturer of spiral stair kits, both metal and oak. The oak spiral stair kit, available in 4-ft., 5-ft., and 6-ft. dia. Metal spiral kit is designed for economy and ease of installation.	Free Circle No. 356	✓	✓	✓			
Lawler Machine & Foundry P.O. Box 2977, Dept. TB Birmingham, AL 35212 (205) 595-0596	Cast-metal components that can be used in fabricating custom handrails and balustrades. Sold through dealers and distributors.	Free						✓
Mansion Industries P.O. Box 2220, Dept. TB City Of Industry, CA 91746 (818) 968-9501	Stairway railing systems: Newels, handrails, and balusters that virtually pop together. Balusters have discs that press into rail sockets at any stairway angle or level run — without sawing, gluing, or nailing.	Free Circle No. 361				✓		✓
Marietta Millworks P.O. Box 7719, Dept. TB Marietta, GA 30065 (404) 425-8724	Produces a patented split bending wood crown mold useful in trimming out junction between a curved staircase and a curved wall. Molding conforms to contour of wall, concave or convex.	Free Circle No. 479						
Millwork Specialties 2197 Canton Road, Dept. TB Marietta, GA 30066 (404) 425-6585	Supplies complete stair assemblies or stair parts: Newels, balusters, treads, handrail, and fittings. Curved, circular, or straight stairs. Select from standard designs or custom work.	Free Circle No. 480		✓	✓	✓	✓	✓
National Decks, Inc. P.O. Box 1125, Dept. TB Alfred, NY 14802 (607) 587-9558	Custom architectural turnings: Balusters, newels, finials, porch spindles. Large or small orders. Can work from architectural drawings or a sample.	Free Circle No. 482				✓		
New England Tool P.O. Box 30, Dept. TB Chester, NY 10918 (914) 782-5332	Fabricates hand-forged and cast metal stair elements for straight or curved stairs and decks. Will work from your specs, or will develop a design from their reference files.	Free				✓		✓
New England Woodturners P.O. Box 7242, Dept. TB New Haven, CT 06519 (203) 776-1880	Custom architectural wood turnings: Newels, balusters, and rail systems. Any wood, any style. Also: Hollow stave work. Restoration work or new construction. Has large equipment; can make turnings up to 40 ft. long.	Free Circle No. 295				✓		
Partelow Wood Turnings 34 Lyme St., Dept. TB Old Lyme, CT 06371 (203) 434-2065	Custom wood turnings: Balusters, newels, fluting, spiral rope twist, finials, column bases. No minimum order. Can furnish any wood and design specified.	Free Circle No. 496				✓		
Piedmont Home Products, Inc. 111 E. Church St., Dept. TB Orange, VA 22960 (800) 622-3399	Line of hardwood spiral stairs, both stock and custom. Custom stairs available in any size from 4-ft. dia. to 8-ft. dia. in heights up to 14 ft. per flight. Standard stairs in 5 sizes from 4-ft. dia. to 6-ft. dia.	Free Circle No. 483	✓					
Rich Woodturning, Inc. 98 N.W. 29th St., Dept. TB Miami, FL 33127 (800) 451-9822	Complete custom stairways, specialty turnings, architectural woodwork, and stair parts. Can do hand carving, as well as fluting and complex rope twists. Also has all Coffman, Arcways, L.J. Smith, and Taney parts.	Free Circle No. 484	✓	✓	✓	✓	✓	✓

Family Heir-Loom Weavers

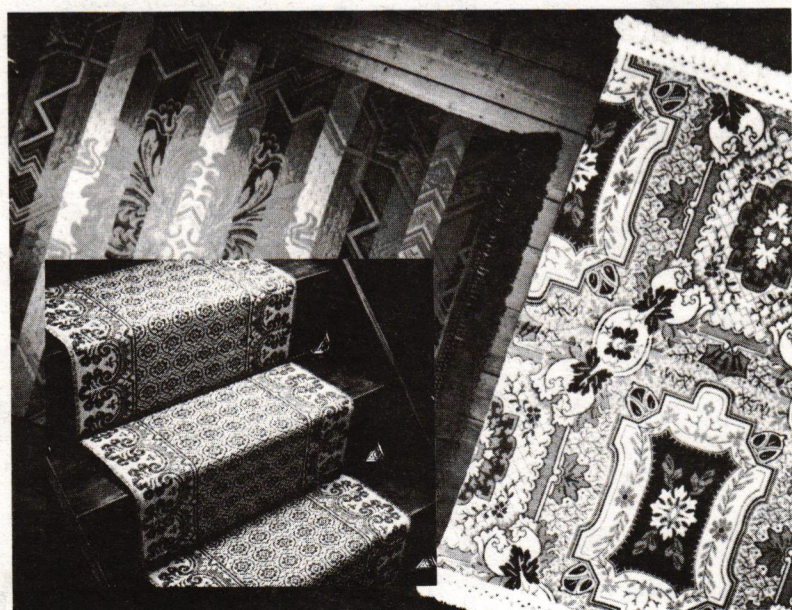

Fancy Jacquard Coverlets and Ingrain Carpets

At Family Heirloom Weavers we offer finest quality all wool two-ply reversible carpet in many 19th century patterns. The Abraham Lincoln home in Springfield, Illinois as well as other historic homes have installed our carpets. Send \$2.50 for a color brochure to:

Family Heirloom Weavers • R.D. #3, Box 59E Red Lion, PA 17356 • (717) 246-2431

Circle No. 508

Buy Direct & Save



3'4" Dia.  
4'0" Dia.  
9' High  
**\$400.00**

Other Heights  
& Diameters  
Available

Fast Dependable  
Service on  
Custom Sizes

1 PIECE WELDED UNIT  
NOT A KIT

Capability to  
Service Multi-dwellings  
and Condominiums  
Standard Models  
In Stock

CALL TOLL-FREE  
1-800-422-3700  
IN PA. COLLECT  
1-814-898-3700



Send for your FREE Brochure  
**SPIRAL STAIRS  
OF AMERICA**

1718 Franklin Ave., Erie, PA 16510

Circle No. 486

Spiral  
Stairs From  
Piedmont.



Innovators  
of quality  
hardwood spiral  
and custom  
stairs. Call or  
write for more  
information.



**Piedmont Home  
Products, Inc.**

111 E. Church Street, Orange, VA 22960  
1-800-622-3399 • In Virginia 703-672-3888  
FAX 703-672-9375

Circle No. 483



## An Innovative Stair System at an Affordable Price

Developers of Unique, Patented, All-Wood,  
Spiral & Curved Stairs  
We can adapt or modify our kits to fit most applications.  
Also metal spiral stair kits



### SPIRAL MANUFACTURING

Call toll free, 1-800-535-9956  
17251 Jefferson Hwy, Baton Rouge, LA 70817

Circle No. 485

Antique Heart Pine Flooring  
Original growth Southern Longleaf Pine  
Quality assured.

**GOODWIN**  
LUMBER COMPANY

Rt. 2, Box 119-AA, Micanopy, FL 32667  
(904) 373-9663

Circle No. 253

...where things  
always turn your way!

**Custom Woodturning Service**

we turn:

- Porch & Stairway
- balusters
- newels
- spandrels
- finials

&

Furniture Parts

FREE BROCHURE  
FREE QUOTES

National Decks, Inc.  
P.O. Box 1125  
Alfred, NY 14802  
Phone 607-587-9558  
FAX 607-587-9398

Circle No. 482

## CHADSWORTH

EXPECT THE BEST

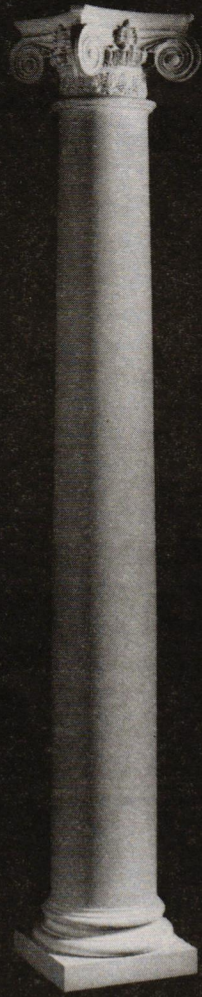

Authentic Replication of  
Greek and Roman Orders

Chadsworth Columns and Capitals available in  
redwood, pine and other species.

EMPIRE WITH NECKING—featured with our  
plain column shaft and attic base moulding—is a  
modern version of the Ionic. The volutes on this  
magnificent capital gradually spiral outward and  
then tighten to form central eyes. Two classic  
mouldings, the egg and dart and the bead and reel,  
enrich this exquisite capital. The necking and the  
abacus are adorned with sprigs of honeysuckle.

Architectural Columns  
French Gobelin Tapestries  
Table Bases  
Pedestals



Column, Tapestry or Table Base Brochure—\$2.00 each  
All Three Brochures—\$4.00

For information and brochures:  
P.O. Box 53268, Dept. 21  
Atlanta, Georgia 30355  
404-876-5410

Circle No. 18

## SPIRAL STAIRWAYS



- Clean Design • Easily Installed
- Any Diameter Possible
- Heights To 1000 Feet
- Complete Single Unit
- \$425.00 And Up When Shipped

CALL OR WRITE FOR FREE BROCHURE  
1-800-231-0793  
FAX 1-713-680-2571



Circle No. 487

## RESCUE DECAYED MATERIALS WITH EPOXIES

Here are 3 uses for Abatron's Restoration Epoxies. If  
you've got a different problem, call us. It's likely we  
have a formulation that will do the job.

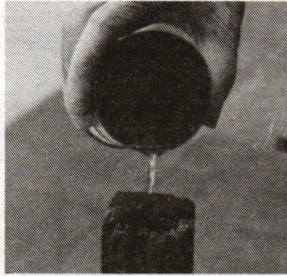

### 1. WOOD RESTORATION

**LiquidWood** and **Wood-Epox** give new life to severely rotted window sills, sash, frames, shutters, columns, decorative wood elements. The Abatron system is especially valuable when original wood must be saved for historic reasons. **Liquid Wood** consolidant reinforces and waterproofs by hardening after penetrating — and is the primer for **Wood Epox**. **Wood Epox** is a structural adhesive putty that fills, repairs, and replaces missing wood.

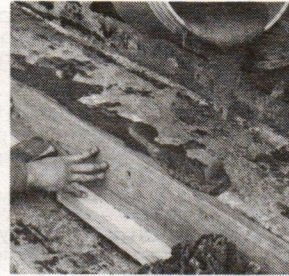

### 2. CONCRETE RESTORATION

**Abocrete**: a patching and resurfacing cement/grout structurally and chemically superior to concrete. Welds permanently to concrete, metal and wood. Patches & resurfaces floors, driveways, work areas, structures, columns, docks, corroded, pitted and spalled surfaces for industrial, marine, institutional and residential uses. **Abocast**: solventless resurfacing materials. **Abocoat**: the toughest protective coatings. Special versions available for applications in subfreezing weather.



### 3. CRACK WELDING

**Abojet** Series of structural crack-injection resins is a proven method to restore structural integrity to cracked load-bearing elements, such as foundations, abutments, swimming pools, concrete pipes, columns, and sculptures. **Abojet** resin is injected into the crack, filling and welding it. **Abojet** makes a permanent bond that is stronger than concrete. Besides concrete, **Abojet** can weld masonry, marble, stone, wood, ceramics, metals, stucco, and gypsum.

Call or write for additional information on these cost-effective epoxy restoration materials.

## ABATRON, INC.

33 Center Drive Gilberts, IL 60136 Phone: (708) 426-2200 FAX: (708) 426-5966

Circle No. 130

## Architectural Woodworking

... for Restoration and  
New Construction:

Doors • Cabinetry • Windows • Turnings  
**Mouldings:**  
Any Wood, Any Pattern

**We Can Match  
Old Patterns!**

**Complete Shop Services  
Retail Sales**

Fine Hardwoods • Softwoods • Laminates • Hardwood Plywood  
Hardwood Veneers • Hardwood/Softwood Moulding  
Cabinetmaker's Tools & Supplies

For literature, send \$1.00 to:

**Creative Woodworking**

26 Friendship Street, Dept. TB  
Westerly, RI 02891

401-596-4463 • FAX: 401-596-3418



Circle No. 384

ARCHITECTURAL  
LATHE & MILLWORK

Custom Turning

316 S. Bernadotte St.  
New Orleans, LA 70119  
(504) 482-0980

Circle No. 472

## STAIR PARTS

- Complete Selection of  
Newels, Balusters, Fittings,  
Handrails
- Oak, Cherry, Mahogany,  
Poplar in stock
- No Minimums
- Immediate Shipment

**Millwork Specialties**  
800-729-2906

Circle No. 480

**STAIRCASES & PARTS SourceList, continued**

COMPANY	SPECIALTY	Literature	COMPLETE STAIRS			STAIR PARTS		
			Spiral	Curved	Straight	Newels/ Balusters	Treads/ Nosing	Rail
River Bend Turnings Box 364 RD#1, Dept. TB Wellsville, NY 14895 (716) 593-3495	Small custom turning shop producing newel posts, balusters, and other specialty turnings in lengths up to 96 in. Any size order accepted.	Free				✓		
Salter Industries P.O. 183, Dept. TB Eaglesville, PA 19408 (215) 631-1360	Supplies metal spiral stairs in standard and custom sizes. Available in diameters from 3 ft. 6 in. to 6 ft. 6 in.; larger sizes are available on request. Shipped knocked down.	Free	✓					
L.J. Smith, Inc. Route 1, Dept. TB Bowerston, OH 44695 (614) 269-2221	Extensive line of stair parts and stair systems for straight, U-type, and L-type stairs. Stair parts and systems are available through distributors. Also has pre-assembled circular and spiral stairways.	Free	✓	✓	✓	✓	✓	✓
Spiral Manufacturing 17251 Jefferson Hwy, Dept. TB Baton Rouge, LA 70817 (800) 535-9956	Supplies curved and spiral stair kits in wood. Sectional curved stair system is a partially assembled stair in kit form; all parts are solid oak. Also has a patented spiral stair with inside & outside handrail.	Free Circle No. 485	✓	✓				
Spiral Stairs of America 1718 Franklin Ave., Dept. TB Erie, PA 16510 (814) 898-3700 (800) 422-3700	Manufactures one-piece welded spiral stairs. Offers optional oak handrails, oak stair treads, and oak panels.	Free Circle No. 486	✓					
Spurwink Spiral Stairs P.O. Box 1397, Dept. TB Portland, ME 04104 (800) 528-7787	Large selection of solid hardwood spiral, quarter-circle, and half-circle stairs. No center poles. Diameters of 4 ft. 6 in. to 16 ft. 11 in. available. Also represents Coffman.	Free	✓		✓	✓	✓	✓
Stair-Pak Products Co. 24 County Line Rd., Dept. TB Somerville, NJ 08876 (201) 231-1111	All-oak spiral stairs in four basic styles. One design, in Philippine mahogany, is intended for outdoor use. Units are custom-manufactured to any specified height and are shipped knocked-down.	Free	✓					
Stairways, Inc. 4166 Pinemont, Dept. TB Houston, TX 77018 (713) 680-3110	Custom-designed spiral stairways manufactured from standard components, both metal and wood. Options available on wood spirals: any diameter, wood species, baluster style, rail, and landing.	Free Circle No. 487	✓					
Steptoe & Wife 322 Geary Ave., Dept. TB Toronto, Ont. Canada M6H 2C9 (416) 530-4200	Manufactures and distributes unique Victorian spiral and straight staircases made from cast iron. Suitable for both interior and exterior use. Options: Baluster styles; polished brass handrail.	Free Circle No. 47	✓		✓			✓
Taney Corp. 5130 Allendale Lane, Dept. TB Taneytown, MD 21787 (301) 756-6671	Manufacturer of wood stairs and stair parts: Custom and stock designs in circular, spiral, and straight configurations. Extensive selection of starting steps, treads, handrails, fittings, newels, and balusters.	Free	✓	✓	✓	✓	✓	✓
Tiffany Stair Co. 16601 Burke Lane, Dept. TB Huntington Beach, CA 92647 (714) 848-4680	Supplies stock stair parts, custom-milled stair parts, and hand-crafted railings — in a variety of design options. Specialists in curved and spiral staircases; large selection of stock stair parts.	Free	✓	✓	✓	✓	✓	✓
York Spiral Stair Route 32, Dept. TB N. Vassalboro, ME 04962 (207) 872-5558	Wood spiral stairs without center pole; inside and outside handrails. Spirals range in diameter from 5 ft. to 8 ft. 6 in. Also supplies a wood straight stair with open risers.	Free	✓		✓			
White River Hardwood-Wdwks 1197 Happy Hollow Rd., Dept. TB Fayetteville, AR 72701 (501) 442-6986	Large inventory of hand rails, rail fittings, newels, balusters, treads & risers, brackets, etc. Also represent Coffman and L.J. Smith. Custom work available. Also handles Challis Stairs.	Free Circle No. 488	✓	✓	✓	✓	✓	✓

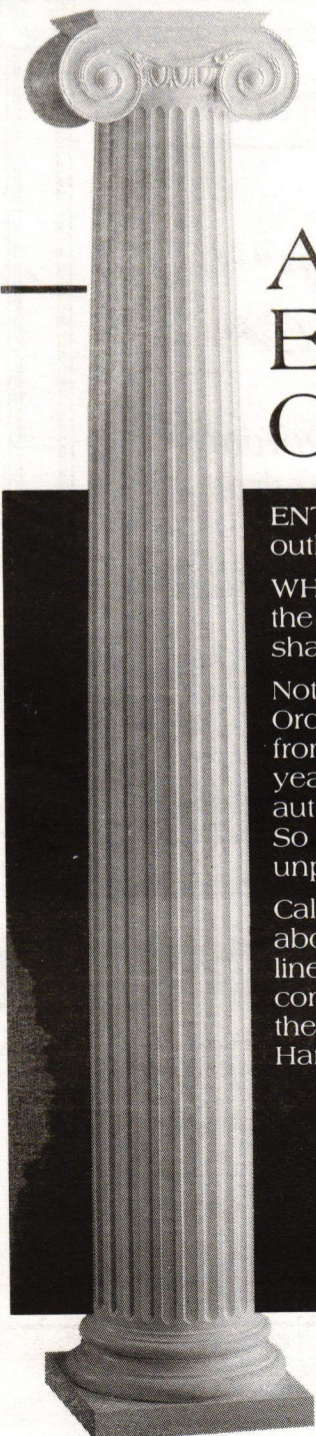

## An Emphasis On Entasis

ENTASIS. A curving outwards along the outline of a column shaft . . .

WHY such an emphasis? To counteract the inward curving optical illusion of a shaft bounded by straight lines.

Nothing less than such attention to the Orders of Architecture can be expected from a company who for more than ninety years has been manufacturing the finest authentic Architectural Columns available. So fine that our redwood columns carry an unprecedented ten-year warranty.

Call us today - or write for information about additions to our expanding product line of other wood and non-wood components and to learn more about the advantages of specifying Hartmann-Sanders.

  
**HARTMANN SANDERS CO**

4340 Bankers Circle  
Atlanta, Georgia 30360  
(404) 449-1561 • (800) 241-4303

An Old Company With New Ideas

Circle No. 158

## Any Curve You Draw On Paper We Can Make In Wood

Just about any millwork shop can make a straight stair. What separates the men from the boys is the handrail: The turns, twists, & curves that characterize the elegant stairways of years gone by.

**Any Wood  
Any Style  
Restoration  
New Construction**

We can rebuild old stairs to duplicate historic originals — or execute a grand new stair for contemporary work. No job is too complex; our 55 shop craftsmen love a challenge. Smaller stairs we will shop-assemble and install on site as a single unit. Larger stairs we will ship K-D and assemble on site.

Call or write to discuss your needs.

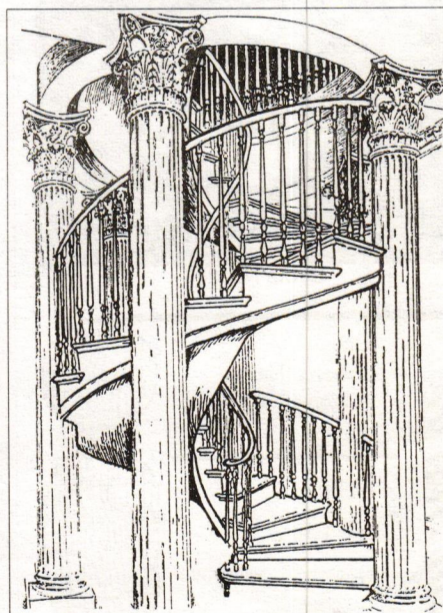

★ **AMERICAN STAIR BUILDER** ★

"Custom Stairs Are Our ONLY Business"

190 Highland Pl. Brooklyn, N.Y. 11208 (718) 647-5600. Call for our fax #.

Circle No. 470

## ANTIQUE WOOD PRODUCTS IN CHESTNUT, OAK, WHITE & HEART PINE, HEMLOCK, AND MORE

Flooring, Beams, Paneling, Barn Siding, Slate, Glass  
AND  
Log Cabins and Post & Beam Frames

**K-WOOD & LOGS, INC.**

P.O. BOX 25, FREELAND, MD 21053  
(301) 357-8108 (301) 641-2622

Circle No. 342

*Authentic Victorian Millwork*  
**MASTER WOODTURNERS**



◆ Produced from original millwork patterns ◆

- ◆ Porch Posts ◆ Newel Posts ◆ Railing ◆
- ◆ Balusters ◆ Corner Blocks ◆
- ◆ Rosettes ◆ Gable Ornaments ◆ Over 100 patterns ◆

All products in Solid Redwood or Clear Heart Cedar; no finger joints or laminate construction. Choose from our authentic designs, or we can custom-turn items from your photos or architectural drawings. *Call or write for quote.*



**CUSTOM WOODTURNINGS**

4000 Telephone Road Houston, TX 77087  
(713) 641-6254

Circle No. 14

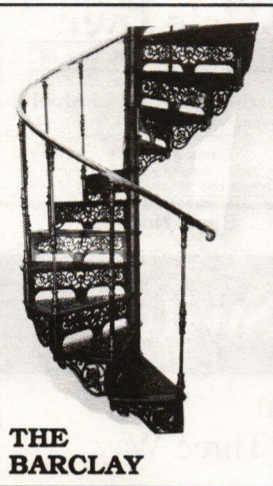

**THE BARCLAY**

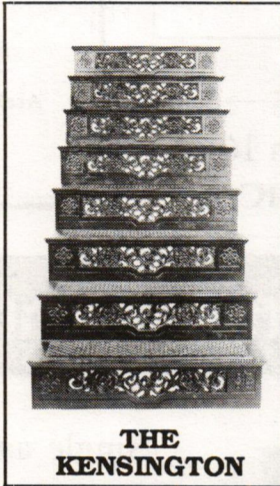

**THE KENSINGTON**

**Steptoe Manufactures & Distributes Quality Restoration Products:**

- Cast iron spiral staircases
- Cast iron straight staircases
- W.F. Norman steel ceilings (Canada only)
- Anaglypta & Lincrusta embossed wallcoverings (Canada only)
- Shower convertos for old tubs (Canada only)
- Brass & steel railing systems
- Lawler cast iron railing & architectural detail (Canada only)
- Custom casting
- Solid teak garden furniture
- Plaster cornice & medallions
- Wood cornice moulding
- Exterior lighting



322 Geary Avenue  
TORONTO, ONTARIO M6H 2C7  
(416) 530-4200 FAX (416) 530-4666

*One Hundred Years Behind the Times.*

Circle No. 47

**All Select-Grade Kiln-Dried Pine Boards**

**W-I-D-E FLOORING & PANELING**

- **Pine:** 12" to 20" wide
- **Oak:** 5" to 10" wide
- **Paneling:** Beaded or Feather Edge
- **Flooring:** Full 15/16" finish thickness; Square, Ship-Lapped Edges

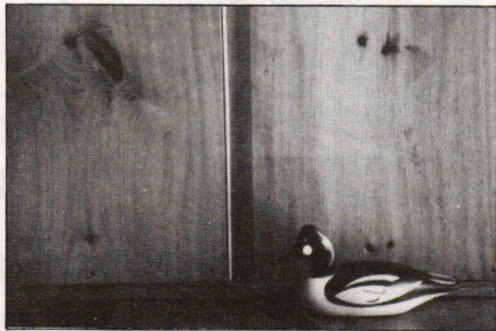

Shipped anywhere in the U.S. For material and shipping quotes, as well as information on installation and finishing, call or write Carol or Dale Carlisle.



**CARLISLE RESTORATION LUMBER**  
HCR 32 Box 679 Stoddard, NH 03464  
(603) 446-3937

Circle No. 145

**CAMERON NORIEGA ATELIER**

**ARCHITECTURAL ORNAMENT**

Complete service from design and pattern making to finished product. We can create or recreate ornament in concrete, plaster, terra cotta or fiberglass reinforced concrete, to your specifications. Whether duplicating existing ornament or creating new patterns from your designs, we offer impeccable craftsmanship at reasonable rates

156 Culver Avenue, Jersey City, NJ 07305  
(201) 332-6827



Circle No. 413

**Traditional Products For Traditional Projects**

Top Quality Wood Products Made From Old-Growth

**Western Red Cedar  
California Redwood  
Douglas Fir  
Yellow Pine**

A Variety of Classic Patterns of Siding, Tongue and Groove Panelings Deckings, Fascia and Trims

Also  
Timbers, Posts and Beams  
Shakes and Shingles

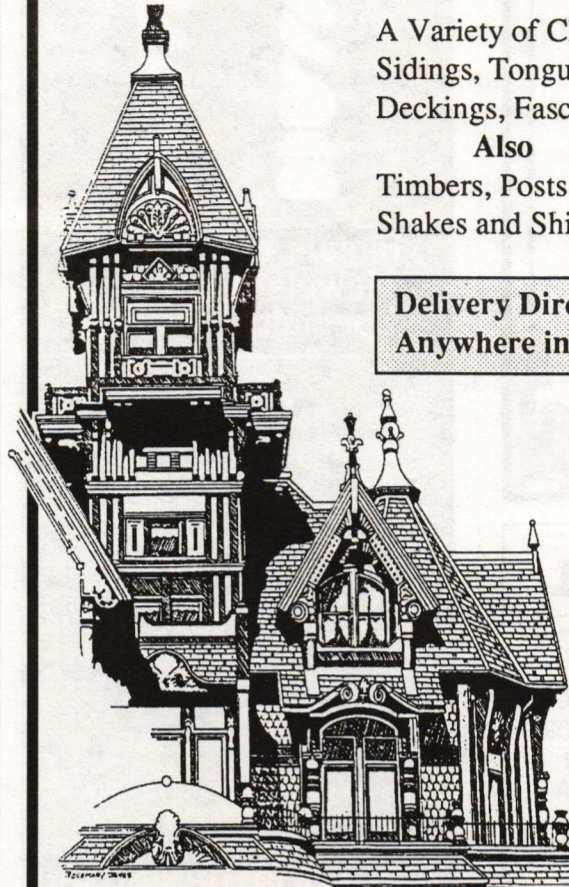

Delivery Direct To Your Jobsite  
Anywhere in the U.S.A.

**Bear Creek Lumber**

P.O. Box 669 Dept. TB  
Winthrop, WA 98862  
Call (509) 997-3110  
FAX (509) 997-2040

Information package \$3.00

Circle No. 202

*Enhance  
your windows  
with shutters  
that are history.*

Authentic louvered or panelled shutters and doors, made to your specifications, from Smart's Mill since 1856. Traditional pintle-style New England mounting hardware now available.

**Beech River Mill Company**

Send \$5.00 for Catalog

Greg Dales, Proprietor Department TB  
Old Route 16 Centre Ossipee, NH 03814 603-539-2636

Circle No. 411

**ConServ EPOXY**  
*Developed for Historic Structures*

- Consolidants
- Patch
- Adhesives
- Structural Repair

- sills / sash railings
- balustrades
- porches / steps
- columns
- siding / trim
- cornices
- rafters / vigas
- beams / posts
- plates / sills / studs
- timber frame / logs

For Product Information  
**Conservation Services**  
8 LAKESIDE TRAIL, KINNELON, N.J. 07405 (201) 838-6412

Circle No. 175

**The Wood Factory**  
AUTHENTIC VICTORIAN MILLWORKS

Screen Doors • Porch Parts  
Custom Woodwork • Moldings  
Ornamental Trim

Send \$2.00 for a Catalog  
901 Harvard, Dept. TB  
Houston, Texas 77008  
(713) 863-7600

Circle No. 337



**ANTHONY**  
WOOD PRODUCTS  
INCORPORATED

Box 1081-TB Hillsboro, TX 76645  
817/582-7225

Illustrated catalog available - \$2.00  
Visa and Master Card Accepted

**Victorian Gingerbread**

Gable Trim	Porch Posts
Fretwork	Newel Posts
Brackets	Balusters
Corbels	Finials

And Much More

Custom Turnings. Custom Sized  
Gingerbread & Reproduction  
Services Available Upon Request.

1979  1989

**CUSTOM  
STAIRWAYS &  
STAIR PARTS**



**Finials ■ Balusters  
Newels ■ Railings  
Specialty Turnings**

Four generations of the Rich Family have maintained the highest standards of excellence in custom hand and automatic wood turnings, stair parts, and monumental stairs. Our staff of specialists will design and fabricate products ranging from delicately turned balusters, newels and porch posts to the elegance of curved and spiral stairs.

Restoration Specialists  
Rope Twists - Fluting - Hand Carving  
Serving satisfied clients nationwide  
for over 50 years.

Send for our spectacular 90-pg. catalog.  
**RICH WOODTURNING INC.**

98 N.W. 29th Street  
Miami, FL 33127  
(800) 451-9822  
FAX (305) 576-1653

Circle No. 484

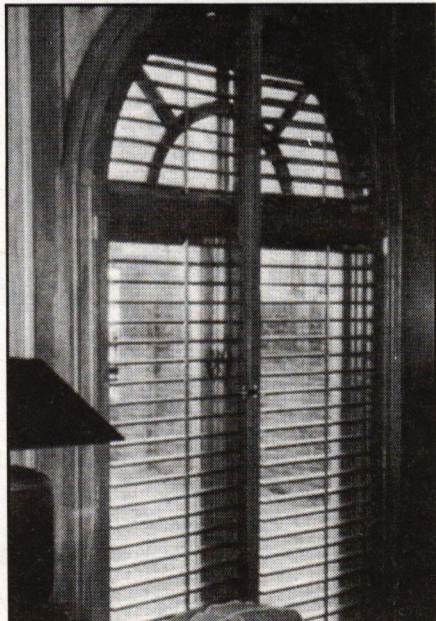

**CUSTOM SHUTTERS**  
INTERIOR • EXTERIOR

Manufactured to your specific requirements  
from the finest premium woods available.

**American Heritage  
Shutters, Inc.**

2345 Dunn Ave., Memphis, TN 38114  
901/743-2800 • 800/541-1186 • FAX 901/744-8356

Circle No. 426

**DUGWOOD  
TURNERS**

Architectural Turnings Furniture

Dug Campbell  
788-8037

P.O. Box 634 Richmond, VA 23205  
6 W. Cary St. Richmond, VA 23220

Circle No. 477

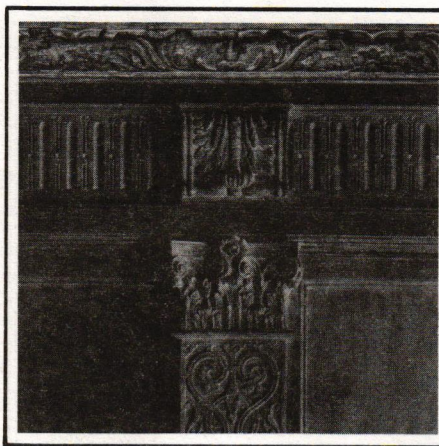

**Oakleaf Reproductions  
of England**

Museum quality reproductions of rare and beautiful cornices, friezes, panels and embellishments. Astonishingly accurate reproductions molded in rigid polyurethane foam, and hand finished by skilled craftsmen. A 34-page full color brochure details these unique products. Brochure cost is \$10.00 refundable with order. Your inquiry is invited.

North American Agent  
J. S. Keller & Associates  
P.O. Box 13151 • Webster Groves, MO 63119  
314/962-6626

Circle No. 491

**Situation Wanted For  
Preservation/Restoration  
Specialist.**

Creative, organized, disciplined professional seeks opportunity with architectural firm.

Call or write for cv/interview:  
Francis M. Gay, 115 Henry St., Apt. 5E,  
Brooklyn, NY 11201 (718) 797-1696.

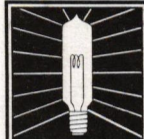

**Division 16  
ELECTRICAL**

We offer a concept...  
not just a product.

**White River**  
HARDWOODS • WOODWORKS, INC.

Manufacturers of  
**Architectural Hardwood Mouldings**  
Ornamentally Embossed & Smooth  
• Reproduction Mouldings •  
Catalog \$3.00

1197 Happy Hollow Road • Fayetteville, Arkansas 72701  
501-442-6986 • 1-800-558-0119 • Fax: 501-444-0406

Circle No. 488

**Push Button Light Switches**

In  
Single and Three Way  
**Solid Brass Cover Plates**  
Decorative and Plain

Also In

- Chrome
- Brown
- Ivory

Finishes

For Color Brochure  
Send \$1.00 to:

**Classic Accents**  
Dept. TB P.O. Box 1181  
Southgate, MI 48195

Circle No. 75

**VICTORIAN  
AND TURN OF  
THE CENTURY**  
Chandeliers, Sconces & Fixtures

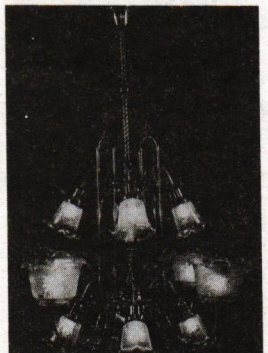

Design • Contract • Manufacturer • Restoration  
• Replacement Parts & Glass Shades

**THE MOST COMPLETE  
SOURCE FOR ANTIQUE  
AND REPRODUCTION  
GAS, OIL AND ELECTRIC  
LIGHTING**  
Lighting Catalog \$5.00

THE FINEST LAMP & FIXTURE RESTORATION AVAILABLE

**ROY ELECTRIC CO., INC. (800) 366-3347**  
SHOWROOM: 1054 Coney Island Ave., Brooklyn, NY 11230  
In N.Y. (718) 434-7002 Fax: (718) 421-4678

Circle No. 43

**ANTIQUE BRASS  
SHOWERS & FIXTURES**



- Claw Tubs • Brass & Chrome Showers • Shower Rings • Pedestal Sinks • Faucets • Oak High Tank Toilets • Cage Showers • Cross Handles • Porcelain • Hard-to-Find Parts • A Huge Selection of Accessories • Expert Advice

**Plumbing Catalog  
\$6.00**

**NEWEL  
POSTS**

ADD THE FINISHING TOUCH TO A NEW OR RENOVATED OLDER HOUSE THROUGH A CUSTOM DESIGNED AND CRAFTED NEWEL POST. CHOICE OF DESIGN, WOOD AND SPINDLES TO MATCH ANY STYLE. EMBOSSED MOLDINGS AND RAISED PANELS CREATE AN UNIQUE LOOK. NEWEL POST CAN BE DESIGNED WITH OR WITHOUT A LIGHT FIXTURE OR FINIAL.

BROCHURE \$2.00

ARCHITECTURAL ACCENTS  
1547 RIDGE ROAD  
MUNSTER, IN 46321  
(219)-838-4331

Circle No. 471

from the Heart of the South  
**Antique  
Pine Flooring**

Newly milled from antique beams

Moldings	Paneling
Cabinets	Doors
Beams	Stairtreads

**ALBANY WOODWORKS**  
P.O. Box 729 - Albany, LA 70711  
504/567-1155

Circle No. 466

**SPIRAL STAIRCASES CUSTOM  
BUILT TO YOUR ORDER**



Complete with beautiful wooden railing. The most attractive and priced far below the rest.

Both all wood and steel models available.  
Prices start at \$385 for Steel, \$995 for All-wood.

Send for full color brochure or call  
913 689-4341.

**Goddard Manufacturing**  
Box 502, Dept. TB, Logan, KS 67646

Circle No. 478

# SENTRY IS LIGHTING UP AMERICA

All across the U.S.A. — from Beverly Hills to the Venice-like Lower Canal in Indianapolis, the Columbia SC governor's mansion, Quincy MA office park, Buffalo NY neighborhood restoration — Sentry luminaires are lighting up parks, streets, plazas, and campuses brilliantly and efficiently.

Sentry offers you a selection of the most beautiful luminaire + post packages in the U.S.A. — or a new design created expressly for you.

Write, call or fax for immediate attention. Sentry sales representation is nationwide.

See us in Sweet's and LAFile.

Sentry Electric Corporation  
185 Buffalo Avenue  
Freeport, New York 11520  
Telephone 516-379-4660  
Fax 516-378-0624

CENTRAL PARK NY



BEVERLY HILLS CA



BATTERY PARK CITY NY

Circle No. 102

## New Lights

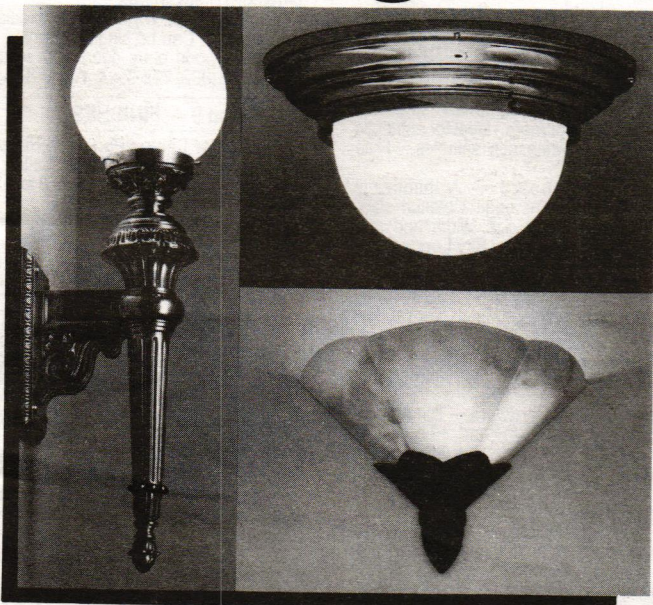

### Urban Archaeology

New 54,000 sq. ft. gallery  
285 Lafayette Street, New York City 10012  
212-431-6969

Circle No. 299

Superb grace of design.

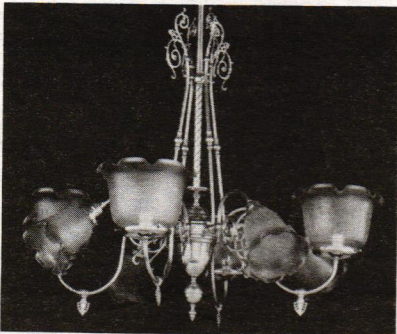
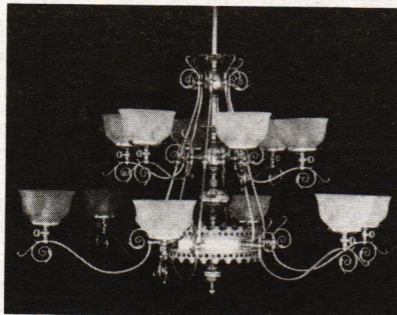

Send \$5 for our full color catalog.  
(catalog fee refundable with order)

251 s. pennsylvania avenue  
po box 469, centre hall, pa 16828  
814-364-9577

Victorian Lighting Works

Circle No. 373

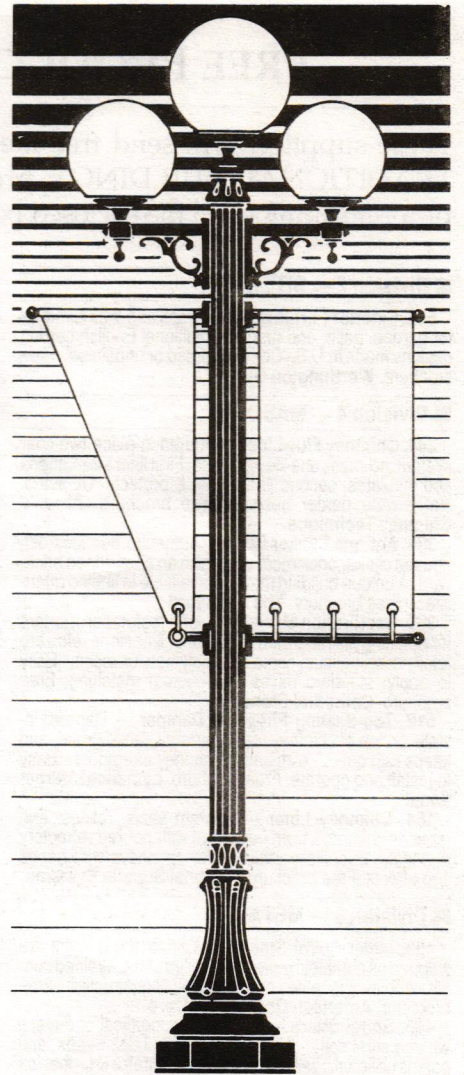

## STERNBERG

Lighting city streets, railroad stations and parks across the country, Sternberg has earned its reputation as a quality manufacturer of historic ornamental commercial scale lampposts, bollards and coordinated wall units.

When making your selection, consider these important features: Elegance and variety of authentic design, heavy duty cast aluminum, welded for single unit construction and durability. Maintenance free, weather resistant and vandal proof. Quality packaging and care in shipping.

Insist on the name that's been a standard of excellence for over sixty years. Call or write for our catalog today. Or see Sweet's File 16512-STE Sternberg Lanterns Inc., 5801 N. Tripp Ave., Chicago, IL 60646, 312-478-4777.

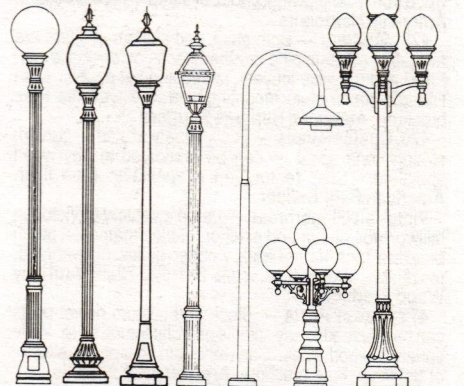

Circle No. 166

## TrimbleHouse

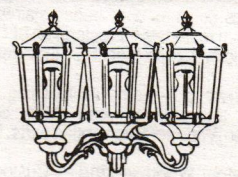

*Craftsmen Preserving America's Lighting Traditions*

4658 Old Peachtree Road  
Norcross, Georgia 30071  
For information call 1-800-241-4317  
In Georgia 1-800-243-9393

Circle No. 105

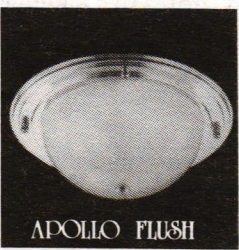

APOLLO FLUSH



THE ORIGINAL CAST. LIGHTING FIXTURES

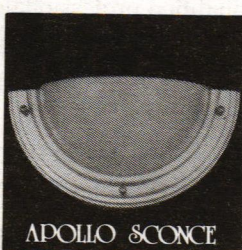

APOLLO SCONCE

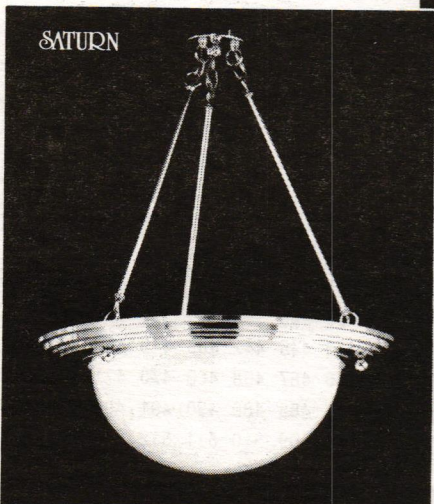

SATURN

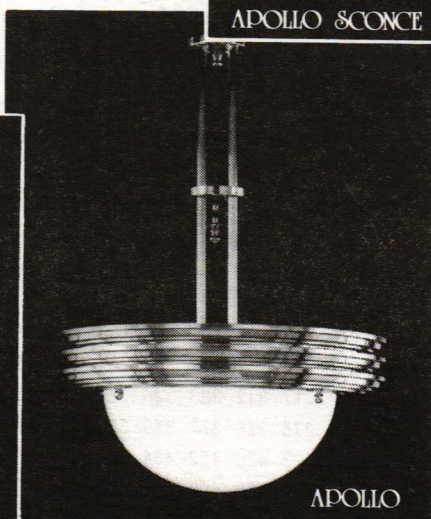

APOLLO

BY Art Directions

6120 Delmar Blvd.  
St. Louis, Mo. 63112  
314-863-1895  
Fax: 314-863-FAST (3278)



Circle No. 436



**PRODUCT LITERATURE**  
*continued from previous page*

pet is woven on 19th-century machinery, using original designs. Hundreds of authentic patterns available. For details and pricing, call: (617) 451-1982. J.R. Burrows & Co.

**19. Tin Ceilings** — 18 patterns of tin ceilings ideal for Victorian homes and commercial interiors. Designs from Victorian to Art Deco. Several exclusive patterns. Comes in 2-ft. x 8-ft. sheets; cornices in 4-ft. lengths. Free brochure. **Chelsea Decorative Metal**

**319. Heart Pine Flooring** — One of the major sources for antique heart pine, reclaimed from both pre-1930 structures and virgin "sinker" logs. Custom millwork as well as flooring available. Free brochure. **Coastal Millworks**

**481. Color Consulting** — Consulting on color and exterior design for buildings. Exterior color schemes for old and new buildings, but specializes in Victorian. Free information packet. **The Color People**

**507. Restoring Decorative Details** — Skills in wood-working, plaster restoration, faux finishes, stenciling, mural painting, and trompe l'oeil can all be brought to bear on restoration projects. Free brochure. **Composition Group**

**515. Molded Ornament** — An extensive line of molded high-density polymer includes cornices, niches, and ceiling medallions. Lightweight, easy to install. Free brochure. **Cumberland Woodcraft**

**Plaster Ornament** — Hundreds of plaster ornaments from late-19th and early-20th centuries — made using original molds. Ceiling medallions, brackets, grilles, cornices, much more. For pricing, call: 312-847-6300. **Decorator's Supply**

**508. Victorian Ingrain Carpet** — Finest quality, all-wool, 2-ply, hand-loomed reversible ingrain carpet and stair runners in classic 19th-century designs. Free brochure. **Family Heir-Loom Weavers**

**449. Faux Finishing Workshops** — Marbleizing, graining, glazing, and other specialty paint finishes taught to professionals in hands-on workshops. Free brochure. **Fe Fi Faux**

**196. Plaster Ornament** — Hundreds of ornaments in fiber-reinforced plaster from turn-of-the-century molds. Also: custom duplication of existing ornament from your sample. Free flyer. **Fischer & Jirouch Co.**

**505. Faux Finishes** — Painting studio offers a complete range of decorating services, but specializes in faux finishes and highly built-up surfaces. Free brochure. **Gary Koeppel Studios**

**253. Heart Pine Flooring** — Virgin growth heartwood from antique southern longleaf pine logs is milled into flooring, panelling, and millwork. Free brochure. **Goodwin Lumber Co.**

**510. Decorative Painting** — Headed by a European-trained master painter, this studio is headquartered in Conn., but does work all across the country. Restoration a specialty, but also executes new commissions. Free brochure. **John Canning & Co.**

**301. Decorative Painting** — Stenciling, glazing, gilding, murals, trompe l'oeil... all the traditional decorating skills can be brought to commercial or institutional jobs in the Northeast. Free brochure. **Kinnari-Silberman Restoration**

**Wood Floors** — Plank floors from Northern Appalachian hardwoods, as well as numerous other species. Three basic flooring patterns and 4 joint styles. Specialize in long, wide, clear planks. Call (207) 897-5211. **Livermore Wood Floors**

**326. Antique Wood Flooring** — Specialist in antique wide-board flooring for 18th-century restorations and colonial reproductions. All wood is planed, ready to install. Free brochure. **Northfield Restorations**

**372. Soapstone Counters** — Custom-cut soapstone available for sinks, countertops, stovetops, fireplaces. Handcrafted griddles, bedwarmers, etc. Free brochure and price list. **Vermont Soapstone**

**52. Sheet Metal Ceilings & Ornament** — Richly ornamented metal ceilings, from original turn-of-the-century dies. Also: exterior cornices and hundreds of sheet metal ornaments. Free catalog. **W. F. Norman**

**503. Flat-Weave Runners & Carpet** — Hand-loomed in traditional Early American patterns, carpet & runners come in wide variety of authentic Shaker, Amish, and Pennsylvania Dutch designs. Free brochure. **Woodard Weave**

Division 10 — SPECIALTIES

**37. Pigeon Control** — Get rid of pigeons and other birds with inconspicuous stainless steel needles that eliminate roosting places — without harming your building. Humane and practical. Free brochure. **Nixalite**

**499. Architectural Salvage** — Enormous selection of architectural artifacts, including large selection of art glass, housed in 360,000-sq.-ft. Chicago warehouse. Free information. **Salvage One**

**46. Historic Markers** — Historic markers in sand-cast bronze or aluminum. Also: Anodized aluminum markers with image permanently embedded in bronze or pewter finish. No charge for photos. Custom work. Free catalog. **Smith-Cornell**

Division 12 — FURNISHINGS

**450. Stained Glass** — Art glass studio does both restoration work and new commissions. Has handled major projects like the Maryland State House. Free brochure. **Artisan Glass Works**

**451. Stained Glass** — All types of stained glass windows repaired, re-leaded, and reproduced. New commercial and residential projects executed in all types of art glass. Free brochure. **Beyer Stained Glass**

**452. Stained Glass** — Custom designers of architectural stained glass and other decorative art glass. Works in many styles. Free brochure. **Casola Stained Glass Studio**

**453. Stained Glass Restoration** — One of the nation's largest art conservation studios has extensive stained glass restoration facilities. Has worked on many major restoration projects across the U.S. Free brochure. **Conrad Schmitt Studios**

**454. Stained Glass** — Major studio specializes in large projects for commercial, civic, and ecclesiastical buildings around the U.S. Has a large restoration department. Free brochure. **Cummings Studio**

**455. Stained Glass** — Small studio restores antique stained glass as well as undertaking new work, mainly residential and ecclesiastical. Free brochure. **Fraser Studio**

**28. Stained & Leaded Glass** — Designer and manufacturer of leaded and stained glass windows, lampshades, architectural pieces, etc. Works from your designs, or will furnish one. Museum-quality restorations. Free brochure. **Golden Age Glassworks**

**456. Stained Glass** — Art glass studio repairs and restores old art glass panels. Also creates new designs for residential, commercial, and church buildings. Free brochure. **Great Panes**

**490. Brass Stair Rods** — Solid brass stair rods are cut to your requirements. Also: Solid brass urn ball and pineapple finials plus fasteners. Easy installation. Free brochure. **Heritage Brass Co.**

**Furniture Brasses** — Solid brass reproductions of

siegel's scratchboard

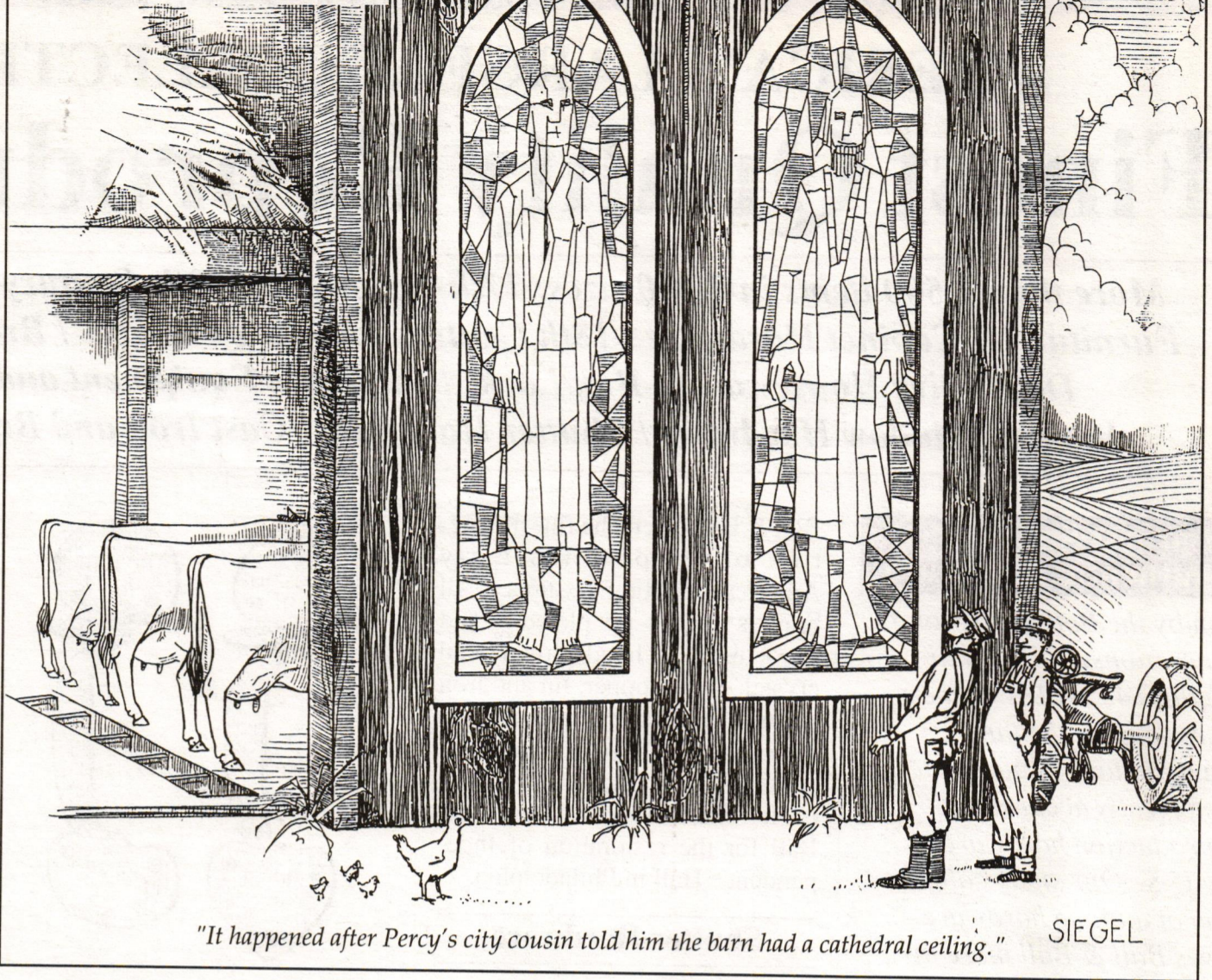

"It happened after Percy's city cousin told him the barn had a cathedral ceiling." SIEGEL

antique originals enhance furniture and provide period touches. Authentic copies of 17th to early 20th century hardware. Call (203) 635-4400 for catalog info. **Horton Brasses**

**457. Stained Glass Commissions** — Designers and manufacturers of custom leaded, beveled, etched, carved, and stained glass windows. Restoration & conservation. Free brochure. **Jersey Art Stained Glass Studio**

**458. Art Glass Commissions** — 57-year-old art glass studio specializes in ecclesiastical and residential commissions in the Mid-Atlantic area. Works in contemporary and traditional styles. **Marchese & Hamersma**

**459. Art Glass Windows** — Studio provides many types of art glass: They can etch, bevel, and slump glass in house as well as fabricate their own wood frames and specialty windows. Free brochure. **Neue Daisterre Glas**

**460. Stained Glass Panels** — Commissions are executed for commercial, residential, and ecclesiastical projects. Works in many styles. Free brochure. **Pike Stained Glass Studio**

**497. Stained Glass Studio** — Specializes in museum-quality American-made reproduction Tiffany lamps and bronzes. Reproduction & period window commissions; repair & restoration. Free brochure. **Porcelli Studio**

**498. Victorian Mirrors & Cabinets** — Features scrolled wood designs with mirrors incorporating stained glass accents. Free brochure. **Ravenglass**

**461. Stained Glass Studio** — Major studio designs and fabricates art glass panels for residential and commercial buildings. Extensive experience in restoration and conservation. Free brochure. **Reflection Studios**

**462. Stained & Leaded Glass** — 70-year-old studio has restored stained glass at five of New York City's most famous buildings. Also executes major commissions in new art glass. Free brochure. **Rohlf's Stained & Leaded Glass**

**463. Stained Glass Restoration** — Large studio maintains a half-dozen crews in the field restoring art glass. Has large inventory of antique glass for making invisible repairs. Free brochure. **Shenandoah Studios**

**500. Stained Glass Commissions** — Designs and fabricates original stained glass to meet exacting client specifications. Free brochure. **Sigsted Studios**

**465. Opalescent Stained Glass** — Large art glass studio houses 3 divisions: Kitchen cabinet door inserts; new work; and restoration. They can get opalescent glass custom-made for special jobs. Free brochure. **Sunburst Stained Glass**

Division 14 — CONVEYING SYSTEMS

**502. Dumbwaiters** — Hand-operated and electric dumbwaiters are appropriate for restorations — and very handy, no matter what the style. Free brochure. **Vincent Whitney Co.**

Division 15 — PLUMBING & MECHANICAL

**172. Bathroom Fixtures** — Major collection of turn-of-the-century and country bath sinks, tubs, toilets, and accessories. Brass, porcelain, and oak furnishings — both reproduction and antique. Free catalog. **Bathroom Machineries**

**53. Edwardian Faucets** — Exclusive importers of authentic English Edwardian and Italian transitional style kitchen and bathroom faucets, fittings, washbasin sets, bath/shower and bidet sets in chrome, brass, gold, and enamel finishes. Catalog. **Watercolors**

Division 16 — ELECTRICAL

**489. Arts & Crafts Lighting** — Lighting fixtures inspired by Greene & Greene: Hand-crafted wood fixtures with art glass panels. Free brochure. **Architectural Rarities**

**436. Authentic Reproduction Lighting** — Art Deco and other turn-of-the-century lighting fixtures are cast directly from original fixtures. Antique fixtures also available. Free brochure. **Art Directions**

**6. Reproduction Lighting** — Handcrafted 18th- and 19th-century lighting fixtures: chandeliers, sconces, and table lamps — all of solid brass. Free catalog. **Authentic Designs**

**75. Push-Button Switches** — Push-button light switches in quality reproductions. Switch plates in plain brass or ornamented. Brochure has details and prices. **Classic Accents**

**43. Vintage Lighting** — Victorian and turn-of-century chandeliers and sconces: gas, oil, and electric. Antique and reproduction fixtures; replacement parts and glass shades. Free catalog. **Roy Electric**

**298. Early American Lighting** — Postlights, chandeliers, lanterns, and foye lights in brass, copper, and tin. All fixtures are hand-crafted. Catalog free to professionals. **The Saltbox**

**102. Exterior Street Lighting** — A variety of traditional poles in both cast iron and cast aluminum, plus a selection of luminaires including rare Art Nouveau and Art Deco styles. Free brochure. **Sentry Electric**

**166. Historic Street Lights** — Large selection of historic cast-aluminum light poles and luminaires, plus matching wall-mounted fixtures and bollards. Free brochure. **Sternberg Lanterns**

**105. Traditional Lighting Selector** — Extensive selection of traditional street lighting; interchangeable components allow mix-and-match of poles, bases, and luminaires. Lighting selector shows look of various combinations. Free brochure. **Trimble House**

**299. New Old Lighting** — A new line of reproduction lighting fixtures includes wall-mounted torchieres, ceiling fixtures and sconces from the turn-of-the-century. Free brochure. **Urban Archaeology**

**373. Victorian Lighting Fixtures** — Authentic reproduction Victorian & turn-of-century electric and gas chandeliers and wall brackets. Variety of glass shades. Catalog free. **Victorian Lighting Works**

Division 16, continued

MAKERS OF  
COLONIAL AND  
EARLY AMERICAN  
LIGHTING FIXTURES

AUTHENTIC DESIGNS  
47 The Mill Road, West Rupert, Vermont 05776  
(802) 394-7713  
Catalogue \$3.00

Circle No. 6

THE SALTBOX



DETAILS COUNT

Postlights, Chandeliers, Lanterns,  
Foyer Lights in Brass, Copper and  
Tin. Catalogue — \$3.50.  
Send to: The Saltbox, Inc.  
500-T State Street,  
Greensboro, NC 27405.  
Phone 919-273-8758

Circle No. 298

# Authentic Historical Hardware

## AMERICA'S LARGEST COLLECTION OF Finest Quality Reproductions

*More than 1,500 items in 2,000 sizes: 17th-, 18th-, and 19th-Century House Hardware / Furniture & Cabinet Hardware / 18th Century Lighting Fixtures / Brass Door Knockers / Decorative Housewares / Box Locks / Fireplace Equipment and Accessories / Door & Window Hardware / Shutter Hardware / Cast Iron and Brass Butt Hinges*

### Largest Supplier Of Authentic Hardware

Run by the Ball family for 3 generations, Ball & Ball employs 45 skilled workers — making us the largest manufacturer of authentic, historically accurate reproduction hardware in the U.S. Our study collection of antique hardware gives Ball & Ball more in-depth knowledge of historic hardware than any other hardware supplier.

#### Box Locks

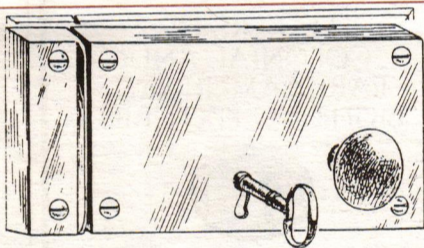

Our X90 locks combine modern convenience with antique charm. The finest originals had this brass box covering an iron plate that had the operating mechanism mounted on it. Because of our attention to historical detail, these locks may be used in the most important restorations as well as in the well-appointed home.

#### Lighting Fixtures



Ball & Ball offers the finest selection of reproduction Early American lighting fixtures. All brass is solid — not plated — and glass used is hand-blown lead crystal. Pure copper, tin and iron are used for fixtures that require these metals. Shown: The Independence Hall chandelier, identical to fixtures supplied by Ball & Ball for the restoration of Independence Hall in Philadelphia.

#### Shutter Hardware

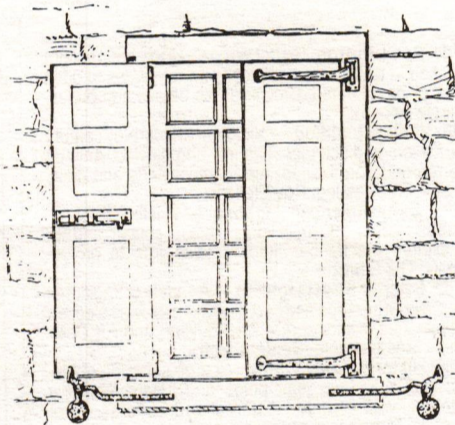

Strap hinges, locks, and shutter hold-backs are available as stock or special-order items. HAND-FORGED shutter hinges with lag screw or drive pintles available on special order. Also: Inside shutter hardware in brass and cast iron.

#### Repair & Duplication

*We can custom-match almost any piece of hardware. (This painstaking custom work is labor-intensive, and as such is not inexpensive.) Our skilled craftsmen can also repair most antique hardware. Call or write for price quote.*

#### Latches

We have a varied stock of authentic reproduction thumb latches,

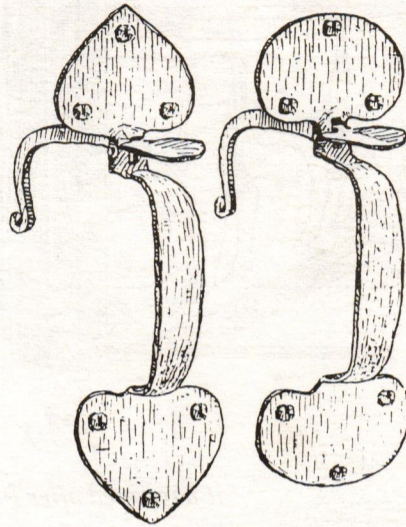

ranging from Colonial times up to 1850. Many special thumb latch shapes can also be made at the STOCK PRICE. Left: 10-1/2" hand-forged spade-end latch. Right: 9-3/4" semi-hand made bean-end latch.

#### Hinges

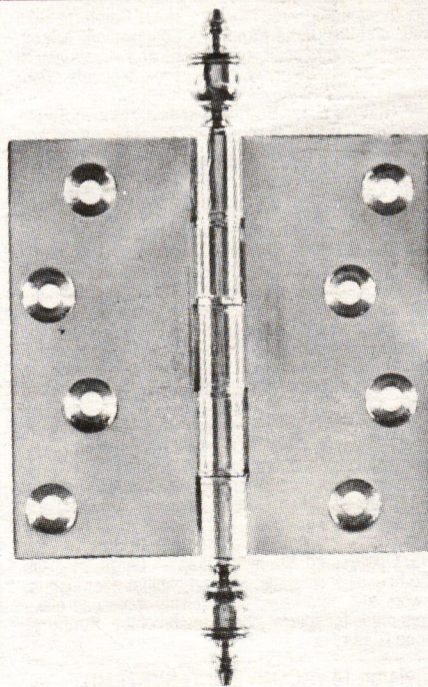

We carry a wide selection of iron and brass hinges from the Early American and Victorian periods. Shown: the H1877 4x4 brass stepple-tip door hinge with bronze load-bearing bushings, typical of the style used in the late 1880's.

### Used In The Finest Restorations

*Ball & Ball hardware has been specified for the finest restorations in North America including: Independence Hall, Philadelphia; The Shirley Eustis House, Boston; Iolani Palace, Hawaii; New York State Capitol, Albany; Klondike Gold Rush Park, Alaska; The Old Synagogue, Barbados.*

#### Window Hardware

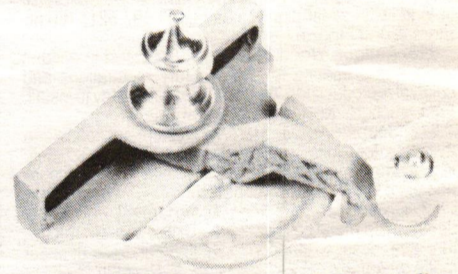

Sash and casement window fittings are available for the Early American and Victorian periods: Hand-forged and cast; iron, brass, and bronze. Above: V150-226 Victorian cast-iron sash lock with porcelain knob. Below: V160-290 brass flush-mounting sash lift.

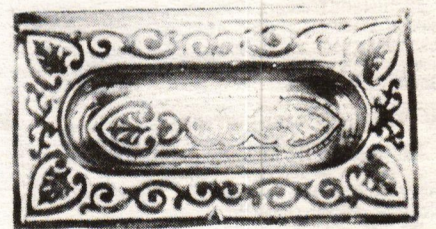

#### Catalogs In 2 Sizes

*Our MINI-CATALOG provides an introduction to the range of products and services furnished by Ball & Ball and is available FREE. (You can Circle No. 293 on the Reader Service Form.) Or for \$5 we'll send you — via U.P.S. — our handsome, lavishly illustrated 108-page product catalog. Our catalog incorporates much useful information about antique hardware that will help you appreciate the subtle differences in the manufacture of reproductions. But even the 108-page catalog doesn't show all 2,000 of our hardware products. If you're looking for something rare or unusual, call or FAX us.*

**BALL and BALL**  
Authentic Historical Hardware

463 West Lincoln Highway  
Exton, PA 19341  
(215) 363-7330  
FAX only (215) 363-7639

Circle No. 293